

# Canton Observer

Volume 5 Number 101

Thursday, July 17, 1980

Canton, Michigan

68 Pages

Twenty-Five Cents

1980 Suburban Communication Corporation All Rights Reserved

## Bush gets the nod

### Michigan delegation gets its wish for VP

By LEONARD POGER  
and MARY CONNELLY-SZCZESNY

It paid off. Michigan delegates to the Republican National Convention early Thursday saw George Bush, their overwhelming choice, picked by presidential nominee Ronald Reagan to be his No. 2 man on the GOP ticket.

They greeted Reagan's 12:15 a.m. announcement with tears of joy, hugs and cheers.

"I'm delighted, excited, thrilled," said Deloris Newell, Westland homemaker and 15th Congressional District delegate. "Bush was my first choice all along."

"TERRIFIC," shouted U.S. Rep. Carl Pursell, R-Plymouth. Pursell noted he was "one of the first and earliest congressmen to declare for Bush for president." But when Bush abandoned his presidential campaign, Pursell and about 15 other congressmen began campaigning openly for Bush for the No. 2 spot.

Sunday afternoon, Pursell hosted a Greenfield Village reception for fellow congressmen. George Bush was at Pursell's side, shaking every hand he could find, for almost the entire three hours.

Pursell said he was bothered by the story — circulated for two hours late Wednesday — that Reagan had cut a deal which made former President Gerald Ford his running mate.

AN ANNOUNCEMENT from Reagan headquarters that Bush was selected ended a wild two hours on the convention floor of Detroit's Joe Louis Arena in which stories circulated that Reagan had picked Ford.

Apparently, the deal fell through. Michigan Gov. William Milliken said, "Probably Reagan and Ford couldn't reach an agreement . . . on the shared responsibilities."



Stories circulated that Ford had wanted a cabinet seat in addition to the vice presidency and that he wanted to share the responsibilities of the presidency.

"A crazy night — one of the strangest I've ever seen," said Milliken.

MICHIGAN VOTERS had supported Bush by a 2-1 margin over Reagan in the May 20 presidential preference primary, and the Michigan delegation reflected that makeup.

"I'm not considering anybody but George Bush," said Rhys Lewis of Redford Township, a 17th District Bush delegate. "It's going to be tough for me to say 'Reagan' unless I can say 'George Bush' with it."

Wednesday morning, Bush visited the Michigan delegation and formally released those pledged to him. Nevertheless, on the first — and final — ballot, Michiganders cast 67 votes for

Reagan, 13 for Bush, one for former Ambassador Anne Armstrong and one uncommitted.

Reagan made it official by announcing that Ford "came to the conclusion he can be of more value as a former president campaigning his heart out."

The former California governor said he picked Bush, a former United Nations ambassador, director of the Central Intelligence Agency, envoy to China, Republican National Committee chairman and U.S. representative from Texas, as "a candidate with great experience in government who can enthusiastically support" the entire platform.

THE SCENE was reminiscent of 1960 when Democratic presidential nominee John Kennedy picked his closest rival, Senate majority leader Lyndon Johnson, for vice president.

Larry Littman, a Bush delegate and 18th Congressional District chairman from Troy, favored Bush because "I really believe he (Reagan) wants to try to put together a ticket that would attract the most voters possible."

"I think he's the only logical choice," said Bush delegate Karen Czernal of Troy. "I think Reagan will want to reach out to all the moderates in the nation."

"I think the Bush delegation from this state — which is the largest Bush delegation at the convention — feels that way to a person," said Lewis.

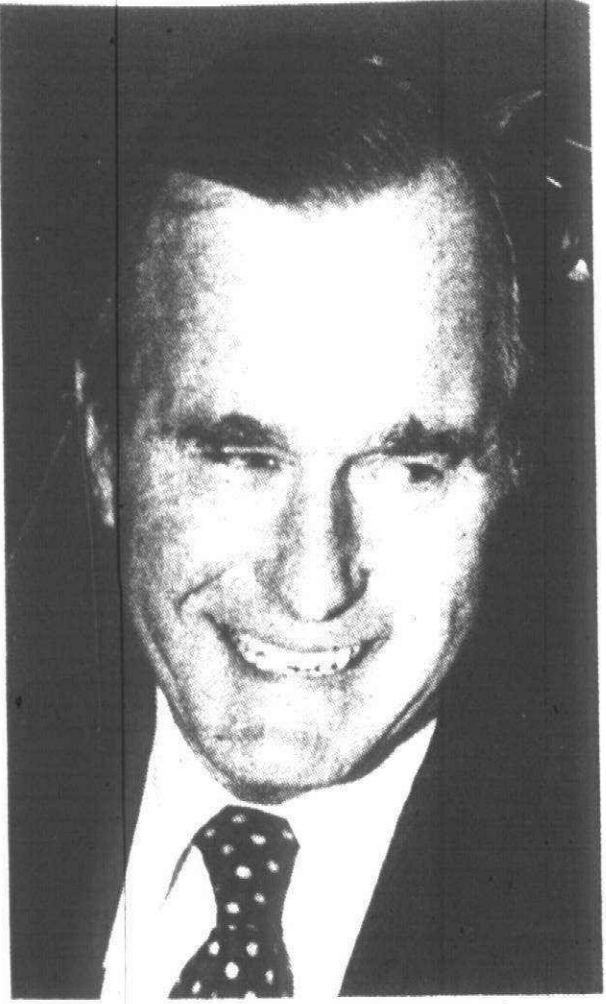

Ronald Reagan had everyone guessing until midnight last night, then he pegged George Bush of Texas to be his vice presidential nominee. Bush, 56, considered a GOP jack of all trades, was Reagan's staunchest foe during this year's Republican primaries. (Photos by John Stano and Art Emanuele)

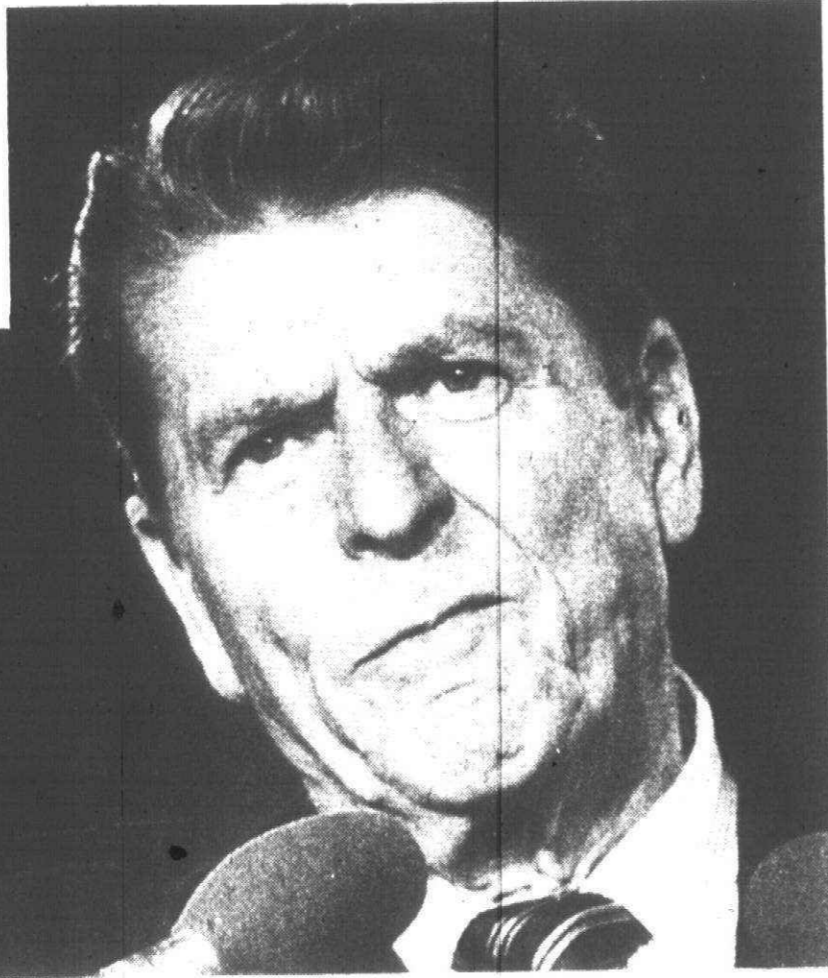

## Mechanic job hangs as board, union disagree

By DARLENE STINSON

Differences between the Township Board and Canton's firefighter union has snagged a 2-month-old pledge for the "immediate" hiring of a diesel mechanic to solve maintenance problems in the fire department.

Township negotiators were scheduled to bargain Wednesday with Local 2289 of the International Association of Firefighters in an attempt to iron out their differences.

The two sides have not met since June, according to finance director Mike Gorman, a negotiator for the township.

At issue is the mechanic's member-

ship in one of two unions, according to spokesmen for both sides.

The Township Board indicated in May that the diesel mechanic would be hired "immediately." The decision was made after a board member received an anonymous letter containing allegations of poor vehicle maintenance. The author charged that oil in one ambulance had not been changed in two years.

A township investigation substantiated many of the charges.

The fire department's first full-time mechanic position was created by the Township Board in October. But the position was not filled by the merit commission until April. The mechanic was

fired for incompetence two weeks later.

DESPITE THE POSITION'S continued vacancy, Supervisor Noel Culbert said all fire vehicles are now "in A-number-one shape."

The township has contracted with

Griffin Co. of Highland Park for basic maintenance and repairs pending the hiring of a full-time mechanic.

Gorman said the township has spent about \$5,000 so far on the contract, which calls for pay of \$35 an hour. The Township Board plans to pay a mechanic about \$20,000 a year.

The township expected to test 25 applicants for the job this week.

Clerk John Flodin, a negotiator for the township, admitted that the mechanic "could possibly have been hired by now" if differences with the firefighters union had been resolved.

The Township Board wants to place

the mechanic in the DPW, where Canton's only full-time mechanic and assistant currently work. The new employee would belong to AFSCME (American Federation of State County and Municipal Employees).

But David Champagne, president of

(Continued on Page 4A)

## Fences stir debate, trustees weigh law

Proposed revisions to the township fence ordinance is creating a subdivision debate on property rights.

About 20 corner lot owners filed into the Township Board's meeting hall last week to hurl their objections at a proposed ban on fences in their sideyards.

Two weeks earlier, the Township Board had agreed informally to strike a provision in the current law which allows sideyard fences with permission of the next-door neighbor.

The restriction applies only to corner lots with side and backyards abutting front yards of homes next door. In those cases, the two houses face an adjacent street.

The board told ordinance director Bruce Phillips in June to ban side yard fences on such lots.

Their decision was based on the number of complaints Phillips has received from homeowners who live next to corner lots.

According to Phillips, the residents have vehemently protested the placement of fences between their front yard and their neighbor's rear and side lot.

In some cases, neighborhood feuds have resulted, Phillips said. In other cases, residents have reluctantly given their permission for fences in the name

(Continued on page 3A)



ANNA BRADLEY



GERALD BROWN



LEO KNASIAK

## Candidates square off

Anna  
Bradley

Gerald  
Brown

Leo  
Knasiak

Anna Bradley says "many people can't possibly care about Canton as much as I do."

A resident of Canton for the past 25 years, Mrs. Bradley served as township treasurer from 1976 to 1978. She lost her bid for re-election two years ago.

Mrs. Bradley, 55, now is attempting to win back the treasurer's job. The position, now part-time, will be a full-time slot beginning in November.

"I was full time anyway. I just got part-time pay," said Mrs. Bradley. "I put in a lot of hours on my own and watched every penny that was being spent."

Mrs. Bradley, a Democrat, is one of five candidates seeking the treasurer's position.

SHE "MOST DEFINITELY" opposes the township's farmland preservation program.

(Continued on Page 4A)

Gerald Brown rates himself as an independent, willing to listen and to compromise. And he believes goal-setting is the way to get things done.

Brown, 49, is a Democratic candidate for township treasurer. The four-year term will combine a full-time administrative slot and membership on the township board.

As an eight-year Canton resident, Brown is making his first stab at public office. He said he would tap managerial experience gained as an Air Force administrative officer and as a company supervisor.

Currently, Brown is an independent safety and loss control consultant and a part-time management instructor at a local college.

"Canton is in a formative period," said Brown. "This four-year period will be very important in Canton's history."

(Continued on page 3A)

Leo Knasiak says Canton needs a professional treasurer.

He cites his background in accounting and finance as qualifications for the job.

For the past 13 years, Knasiak has worked in the accounting and controller office of Ford Motor Co.'s Parts & Service Division, with responsibility in budgeting, auditing, forecasting and other areas.

He holds a bachelor's degree in business administration from Eastern Michigan University.

Now, at 36, Knasiak is seeking his first township office as a Republican. He has arranged for a leave of absence from Ford to work at the treasurer's job fulltime.

One other Republican and three Democrats also are vying for the position.

(Continued on Page 4A)

## Retailers consider making up

By ARLENE FUNKE

Some Canton business people — at odds over how retail can snag shoppers' interest — may be ready to kiss and make up.

A group of shop owners is considering the possibility of calling off its plans to form a retail merchants association. The association, which would be separate from the Canton Township Chamber of Commerce, would concentrate on special events, sidewalk sales and blockbuster promotions.

Gary Roberts, who has been spearheading that move, now says he "hopes" the group can remain within the chamber. Roberts owns a vacuum cleaner and sewing machine shop.

Also leading the drive have been owners of a beauty salon, a restaurant, a delicatessen and a handful of others. Roberts said there also are about 23 other "enthusiastic" supporters.

"We aren't getting our fair share of business," said Roberts. "Most chambers have a merchants committee, and they run their own show. I tried to do this a year-and-a-half ago, and nobody showed any enthusiastic moves."

"I AM HOPING we see it's feasible (to stay with the chamber)," he continued. "That was my original attitude, to be separate. Hey, it depends on what the chamber has to offer."

Frank McMurray, president of the chamber of commerce, agrees that small shops need more business.

He believes that township officials should work through the chamber of commerce. He also says the community needs the support of residents.

McMurray has operated a State Farm Insurance agency in Canton Township for 11 years and has lived in the community for 17 years.

Last month, Gov. Milliken named

(Continued on page 3A)

Brevities	5A
Canton Chatter	2B
Clubs in Action	7B
Obituaries	2A
Opinion	14A
Readers Write	2A
Stroller	14A
Sports	1C
Suburban Life	1B
The View	1B
Classified	Sec. C-D

It didn't take long for B.B. Nicholas to find the right buyer for his lapidary equipment. That's because he sold it the easy way, with a classified ad in his hometown newspaper. No matter how unusual or specialized your used items may be, we're the best marketplace in the area. Call us today.

591-0900

# Visitors from England welcomed

By W.W. EDGAR

The strong bonds of friendship that have been forged with the people of Plymouth, England, over the years have made our fair city the mecca for visitors from all parts of England and the British Isles.

They have been attracted here by the fact that some years ago the late Lord Mayor Frank Chapman personally delivered a bit of rock hewn from the dock from which the Mayflower sailed and made of it a gift to the city. The

visitors come to see how the rock was received and how it looks on American soil.

The latest group visited City Hall Tuesday morning and they came as the guests of Rex E. Umney, a native of Rugby, England, who now lives on Aspen Drive in Plymouth Township.

In the group were his mother, Mr. and Mrs. O. Guskj, and John and Hazel Malaszczuk.

"We live about 160 miles from Plymouth, England, but we heard so much

about Plymouth, Mich., that we just had to pay a visit."

During their stay at City Hall they were shown around by Mayor Mary Childs and City Manager Henry Graper. And to make their visit all the more official, they brought a series of sketches of their hometown and presented them to Mayor Childs as a gift from Rugby Mayor Keith Judge.

In turn they were given gifts for the mayor in return.

In his message to the people of Plymouth, Mayor Judge wrote:

"Some friends of mine are visiting your country, and I have taken the opportunity of using them to present some small token of friendship.

"I know that the Americans are proud of their way of life and rightly so. We, too, are proud of ours. Often we compare the two, sometimes to the advantage of one and sometimes to the other. Yet, although there are many differences there are more points of similarity and on the fundamentals, the ideas of decency and freedom and justice, the to peoples are one.

"I am personally convinced that our friendship with the United States of America is one of the great bulwarks of peace in the world today.

"May I wish you all good health and happiness in the future.

"Yours Most Sincerely, (signed)

Keith Judge.

Mayor of Rugby. The visitors were delighted with what they saw in Plymouth and the municipal buildings along with Kellogg Park. But they fretted about the heat, claiming they never experience anything like it at home.

Aside from being thrilled by the July Fourth Parade and the treatment they have received, they will take home memories of two other places — Niagara Falls and Frankenmuth, Mich.

They admitted they never would forget the sight of Niagara Falls and the thrill of watching the water cascading down into the river and the sight of the little pleasure boat whirling through the rapids.

But they also admitted that never in their life had they seen anything to match the chicken dinner at Zhenner's in Frankenmuth.



Greetings between Plymouth, England, and Plymouth, Mich., were exchanged again at the rock by the library and city hall as visitors from Rugby, England, were welcomed. Seen through the hole in the

monument are: (from left) Mr. and Mrs. John Malaszczuk, Mayor Mary Childs, Rex Umney, Shirley Gurskij, Olelsa Gurskij, Mary Karpiv. (Staff photo by Gary Caskey)

from our readers

## Thanks for coverage

Editor:

On behalf of Huron Valley Girl Scout Council I would like to take this opportunity to thank you for the excellent news coverage the Plymouth-Canton Observer has given Girl Scouting this year.

Girl Scouting's increased awareness in the area has made it possible for Huron Valley to offer the Girl Scout program to a greater number of girls during the past year.

Besides publicizing the positive aspects of Girl Scouting, the news coverage has aided Huron Valley with increased visibility and improved image in your community.

Again thank you for your support.

Valley Girl Scout Council is a United Way Agency.

BARBARA RADABAUGH  
Public Relations Director

# Plymouth-Canton OBITUARIES

### JOSEPHINE BENNETT

Funeral services for Mrs. Bennett, 64, of Honeycomb, Canton Township, were held recently in Schrader Funeral Home in Plymouth with burial at Newburgh Cemetery, Livonia. Officiating was the Rev. Jack Giguere.

Mrs. Bennett, who died July 8 in St. Mary Hospital, Livonia, was a lifelong resident of Plymouth and Livonia and was a homemaker.

Survivors include: husband, Orville; daughters Kathryn Richart of Channel View, Tex., and Gail of Redford; sons, Alton of Detroit and Joel of Canton; brothers, Eugene Wyman of Lake Orion, Neil Wyman of Lake Orion, Charles Wyman of Warren, Raymond Wyman of Auburn Heights; sisters, Katherine Pierce of Laporte, Ind., and Hazel Atkins of New Haven; and by five grandchildren.

EDMUND A. PODSIADLIK

Funeral services for Mr. Podsiadlik, 58, of Pine Street, Plymouth Township, were held recently in Our Lady of Good Counsel Catholic Church in Plymouth

with burial at St. John Cemetery in Ypsilanti. Officiating was the Rev. Francis C. Byrne and arrangements were made by Schrader Funeral Home.

Mr. Podsiadlik, who died July 10 at home, was a crib attendant in manufacturing and a lifelong member of Plymouth. A retiree of Ford Motor Co., he was a member of VFW 6695 Mayflower Post in Plymouth.

Survivors include: wife, Mary; brothers, Al and Anthony Podsiadlik; sisters, Isabelle Colbath and Irene Chivas.

JAMES L. FISHER

Funeral services for Mr. Fisher, 28 of Novi, were held recently in Sault Ste. Marie with a memorial service at Holy Family Church in Novi. Memorial contributions may be made to Brighton Hospital, Brighton.

Mr. Fisher, who died July 6 in Sault Ste. Marie, was a truck driver for Delta Concrete of Plymouth. Survivors include: wife, Susan; step-daughter, Kelli Robinson; parents, Lewis and Virginia Fisher; sister, Joann Luxon of Royal Oak; and aunt, Eva Hupp of Novi.

# \$237,000 LA-Z-BOY® SUMMER STOCK SALE

ADD THAT SPECIAL LA-Z-BOY® FEELING TO YOUR SUMMER AND SAVE!

In addition to the three featured styles, you'll discover a fine selection of 19 other styles at savings of up to 20% off the low everyday Showcase Shoppe price.

THREE GENUINE LA-Z-BOY®  
RECLINA-ROCKERS®  
AT ONE LOW PRICE

**\$199.95** each

TRADITIONAL  
TRANSITIONAL  
CONTEMPORARY



The La-Z-Boy® Reclina-Rocker® shown at left is a favorite. We offer it now in a Scotch-guard protected DuPont 100% nylon velvet at \$120 off our everyday low price. Choose gold or green.

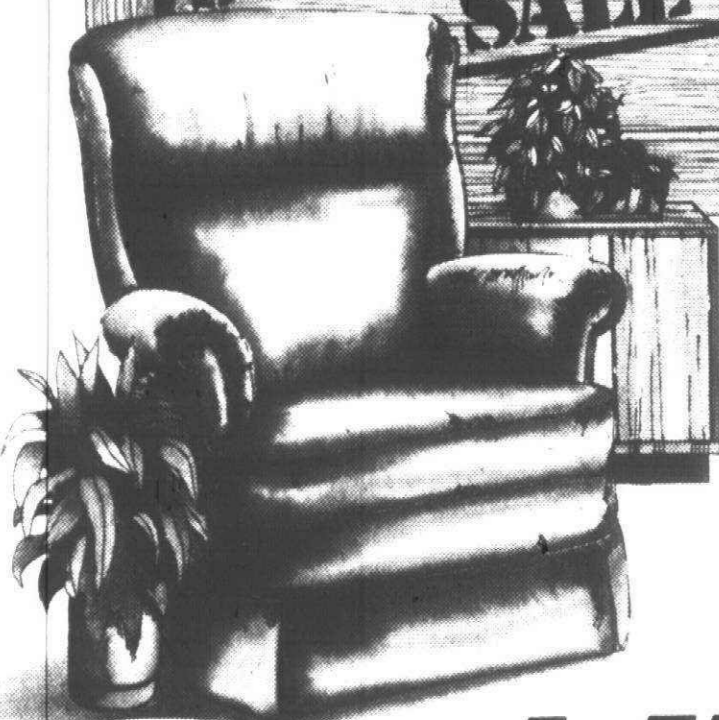

**LIFETIME WARRANTY**  
The LA-Z-BOY® chair has a Lifetime Warranty on all parts of the patented reclining mechanism. Lifetime means the useful life of the chair as determined by the user. At any time, LA-Z-BOY® will repair or, at its option, replace its reclining mechanism or any part thereof, without charge, except any cost of packing and shipping.

**ENJOY MAXIMUM SAVINGS**  
Due to the ease of handling La-Z-Boy® products, all merchandise is tagged with low "Take With" prices. Delivery available at a nominal charge.



**La-Z-Boy** Factory Authorized  
**Showcase shoppes**

NOW 4 STORES TO SERVE YOU

**WARREN** 12 Mile Road at Hoover 574-2440  
**TRENTON** Van Horn at Fort (Trafford Sq. Ctr.) 676-8900  
**NOVI** 1.96 at Now Rd. Exit (Adjacent to 12 Oaks) 349-3700  
**ANN ARBOR** Washtenaw 1/2 mi. east of US 23 (In the New Kroger Center) 434-7575

OPEN WEEKDAYS 10AM-9PM SATURDAY 10AM-6PM SUNDAY 12-5PM

## 45¢ BREAD? EVERYDAY AT the Bakery Outlet

Daily 9:30-6  
Fri. 9:30-7  
Sat. 9:30-5

31511 PLYMOUTH  
LIVONIA  
421-4833

Save during our Mid-Summer Sale!

Finally,  
a sofa sale with  
real FLAIR!

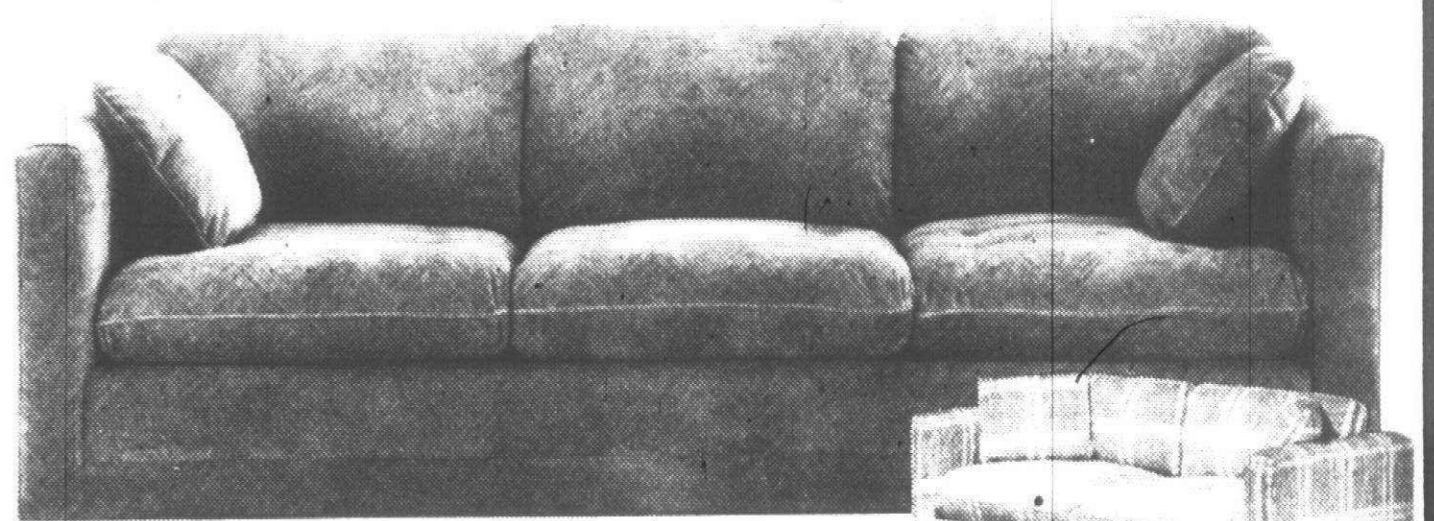

Here's your chance to own this fine furniture by Flair at real savings.

Luxurious 88" Tuxedo sofa and matching 64" love seat. Quality Flair construction throughout, and both have reversible seat and back cushions with knife-edge welting. Available in a selection of 6 Herculon covers at these sale prices or may be special ordered in your choice of 1,000 other covers.

	Reg. Price	Sale Price
Sofa	\$1,117	\$699
Love Seat	\$1,001	\$649

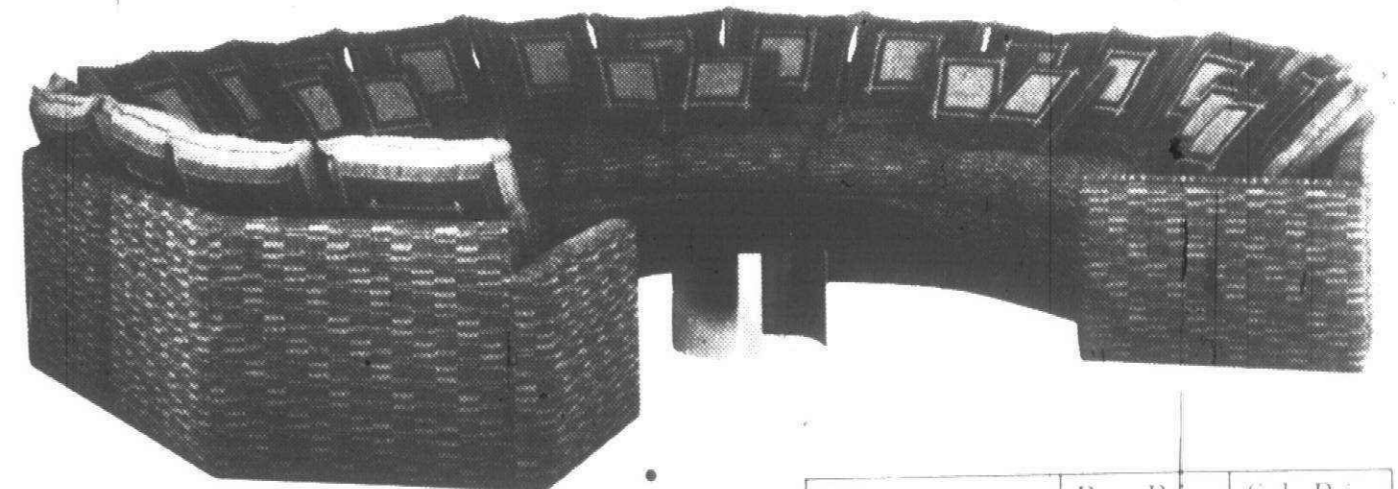

The Towne and Country Treatment. You'll find no salespeople at Towne and Country Interiors — only IDS or ASID interior designers to help you. Our pay-no-more policy and 3 year construction warranty ensure your satisfaction.

Flair contemporary angled, sectional sofa exclusively at Towne and Country Interiors. Shown in rust on white, nubby textured Scotch Guarded fabric. May also be ordered in a selection of 1,000 custom fabrics.

	Reg. Price	Sale Price
Right or left arm 58" sections	\$873	\$679
56" Armless Sections	\$851	\$629
All 4 pieces	\$3,448	\$2,595

Mid-Summer Sale ends August 30

# Towne and Country Interiors

Dearborn 565-3400 23600 Michigan Ave. east of Telegraph  
Bloomfield Hills 642-8822 4107 Telegraph at Long Lake Rd.  
Rochester 652-3500 1110 S. Rochester Rd. in Winchester Mall  
Open daily 10-9 Wed. & Sat. 10-6 Use our convenient charge, Visa or MasterCard



Christine Adamick, an employee of Alternative Services, tidies up a group home on Haggerty south of Cherry Hill while residents are away. (Staff photo by Gary Caskey)

# Settling in new home Retarded adults bid institution farewell

By ARLENE FUNKE

Once Bonnie finishes setting the table for dinner and cleaning up after a meal, she may decide to watch TV or talk to her new roommate. Evelyn and Betty are excited about the prospects of backyard cookouts, new clothing and more flattering hairstyles. Bonnie, Evelyn and Betty recently moved into a sunny, ranch-style home with yard and garden located on Haggerty Road near Palmer in Canton Township. Retarded, ranging in age from 20's to 40's, they are learning a more independent lifestyle.

A total of six retarded women live in the home, attending school or working in a sheltered workshop during the day. Employees of Alternative Services, a non-profit corporation, supervise the women 24 hours a day.

Alternative Services also has another group home in Canton on Roundtable, south of Palmer and east of Morton Taylor. That home, for six retarded men, is a colonial-style home with country kitchen, formal dining room and backyard.

Alternative, based in Royal Oak, is expected to open another home on Warren Road near Haggerty in September, said Rich Bennett, a regional supervisor for all three homes.

Under state law, mentally retarded persons may be placed in community group homes if they would benefit from a non-institutional lifestyle. Homes cannot be located within 1,500 feet of an existing facility.

"SOME OF the clients have lived in the community, some had lived with their families," explained Bennett. "We look at this as a step in a continuum from very restrictive to less (restrictive)."

The two Canton homes, which opened a couple of weeks ago, have aroused mixed feelings among neighbors. Staff members have held meetings and receptions with area residents.

At the Roundtable site, some neighbors had been upset when the group home was proposed several months ago. During recent weeks, Bennett

said things have been "pretty quiet."

One neighbor continued to be opposed. But another served iced tea to the group as they were moving in, and a third has offered to make repairs around the house, said Bennett.

In the meantime, Alternative plans to hold shared social events with clients from both homes. Women will receive new hairstyles, and new clothes will be purchased.

"Institutional life has a way of aging a person more quickly," explained Bennett. "It's easier to cut their hair very short and dress them in the same style of clothes."

**OTHER SKILLS** to be learned will be shopping, banking and household chores.

"Social skills are very important," said Beth Smith, house supervisor of the Haggerty site. "(The clients) recognize each other from the institution. It's enjoyable to watch. It's probably the most important thing now because it was lacking (before). They have come a long way in this time."

"It isn't an across-the-board assumption that these people are going to be able to handle (only) the smaller things," said Bennett. "There may be other areas we will need to substitute."

Smith is a Canton Township resident who has worked as an attendant at the Plymouth Center for Human Development. She also has worked as an instructor at Northville State Hospital, a psychiatric facility.

Bennett, regional supervisor for Alternative Services, has worked with mentally retarded at several facilities since he graduated from Alma College in 1973.

The only way to normalize (mentally impaired) is in a community," said James Hunt, director of the Northville Residential Training Center. "Some of them don't speak well, but you can see their enjoyment in their eyes."

"It's their (home) and it isn't a drab institution," he added.

# Sideyard fences stir controversy in neighborhood

(Continued from Page 1A)  
of good neighbor relations.

Some claim that the fences destroy the front-yard appearance of the entire street.

Last week, however, the Township Board received a different view of the issue.

Sharleen Immonen presented the board with a petition signed by 49 residents in support of side yard fences. A letter from Mrs. Immonen called for a four-foot height restriction on fences which would border the front yard of neighboring property. "It deprives me of use of my yard," one resident said of the proposed ban. "All I'm asking for is my property rights without inhibiting my neighbor's visibility."

A newcomer to Canton said he "felt embarrassed to knock on this fellow's door and ask permission to construct a

fence on my own property."

After a 1½-hour discussion, trustees indicated they may reconsider the issue. They voted to table the matter and seek an attorney's advice after Trustee Carol Bodenmiller expressed concern about changing the zoning ordinance.

The four-month-old ordinance prohibits any permanent structures in setback areas.

The board also directed Supervisor Noel Culbert to schedule a study session and informal hearing on the fence issue.

Culbert said the meeting may be scheduled for the fifth Tuesday in July. But he expressed distaste at holding the meeting before the Aug. 5 primary.

"I'm not holding that thing before the election," he said. "The board directed me to hold a study session on fences. They didn't say when."

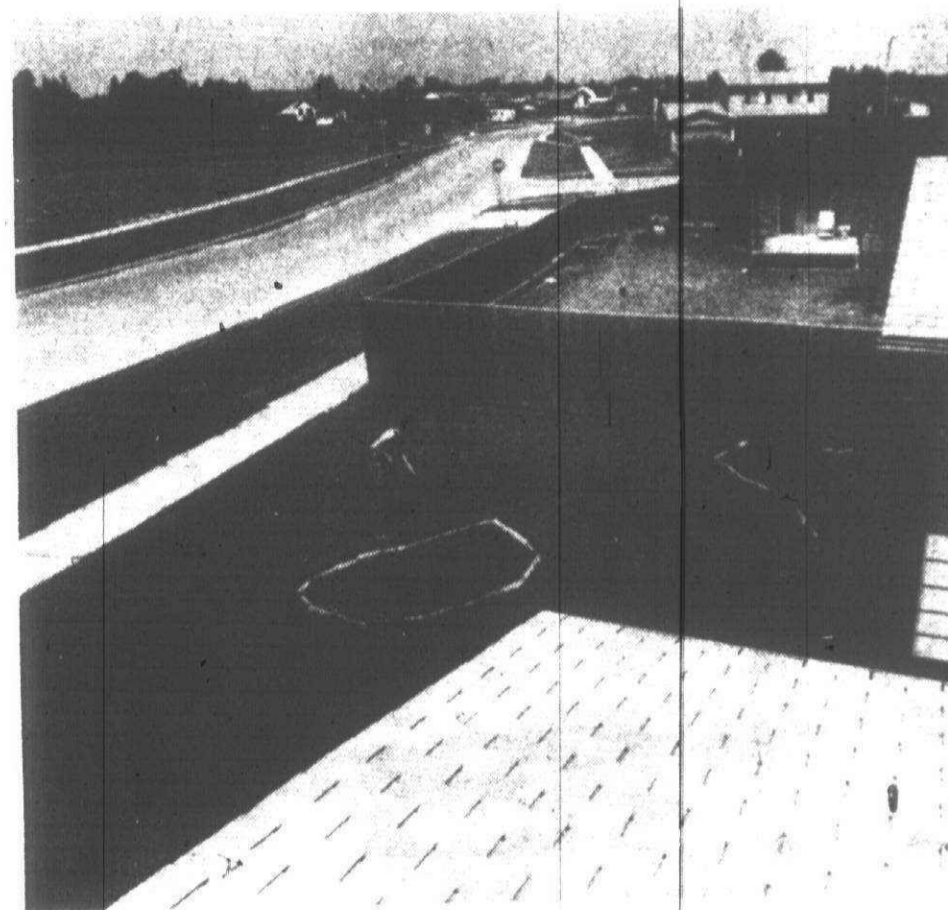

Corner-lot fences, which jut into neighboring front yards, have become a topic of controversy. (Staff photo by Gary Caskey)

# Brown faces issues of treasurer's race

(Continued from Page 1A)

Brown said he would spend the first few months becoming familiar with the township's finances and then map out a plan to invest surplus. He noted that residents recently have approved tax increases for police, fire and library services.

"I have no ties to anyone," said Brown. "I would hope I don't have any allies at the moment. And I would hope I don't have any adversaries."

"WHEN PEOPLE see their new tax bills this fall, it will be very difficult to get anybody to vote for tax increases," said Brown. "I have been unable to find out" the financial condition of the township.

Brown also supports farmland preservation and better relations with the business community.

"The advantage for developers isn't there, the way it was four or five years ago," said Brown. "That property is zoned agricultural. It would be very difficult to legally retain agricultural use unless farmers get some form of tax relief within 24-36 months."

"I don't think as elected officials, we can play around with their estate forever," added Brown.

Brown said he is glad to see that the Chamber of Commerce and the current Township Board are moving toward more cooperation. The board recently approved the formation of a task force to investigate problems of business people over zoning ordinances and signs.

"The problems of the small businesses are colossal," said Brown. "Many people have a lifetime dream to own a business, and sometimes it seems Canton tries to make it into a nightmare."

Brown also said he would like to get out into the community and talk to residents about their hopes for the township. For example, do residents want more recreational facilities? Would they prefer more "passive" areas, such as picnic grounds, or more active recreation such as tennis courts or team facilities?

Brown said his five-year goal is to have Canton Township residents satisfied with their community and "feel about it the way Dearborn residents feel, especially cleanliness and beauty."

"Canton is a pretty good place to live," said Brown. "I have no particular quarrel."

# Shops may return to fold

(Continued from Page 1A)

Last month, Gov. Milliken named McMurray to an 11-member statewide small business council. The group will work with the state Department of Commerce in sponsoring a small business conference early next year.

"PEOPLE ARE beating their heads against the wall to stay in business," said McMurray. "Businesses are going down the tubes, but who cares?"

"We need the support of the residents," he continued. "Why not shop in Canton?"

According to McMurray, there are about 150 members of the Canton chamber. He said about half are retail merchants, with the rest a variety of business and professional persons such as physicians, attorneys, etc.

"The chamber feels that as (the retail merchants) organize, it should come under the chamber," added McMurray.

Both Roberts and McMurray say business people have been hampered by some of the township's strict regulations on signs and zoning. They say it makes it difficult for business people to promote special sales and events.

McMurray said the township board's approval last week of a task force to study business problems is a sign that the board "recognizes there is a need." The committee, which is being developed, was suggested by the chamber of commerce.

"We have to create an environment that businesses can be welcomed into our community," said McMurray. "I guess our concept is that we (business people) would like the township to seek our advice when they are passing ordinances."

"We feel we have some issues which can be dealt with immediately," he added.

# Statewide teen contest slated

The statewide competition for the Miss Michigan Teenworld crown is under way with the official awards ceremony slated for July 25-27 in Kalamazoo.

Young women from all over the state will compete in the Michigan Teenworld Pageant and will be judged on scholastic and civic achievements, appearance, personality, and a speech or talent presentation. Entrants must

be ages 14 to 18 as of Dec. 31, 1980 and must maintain a "B" or better school average. No swimsuit competition is involved.

For details on the Miss Michigan Teenworld competition write to Pat Erickson, state director, Teenworld Regional Offices, 300 Fox Hill Office Center, 4550 W. 109th Street, Overland Park, Kan. 66211.

## Family Discount Drugs

Package Liquor Dealer

 <b>CALADRYL</b> GENERATING ITCH RELIEF FOR GENERATIONS 6 OZ. <b>\$1.91</b>	 <b>SCHOLL SPORT CUSHIONS</b> SUPER SHOCK ABSORBING INSOLES PAIR <b>\$1.44</b>	 <b>DR. SCHOLL ODOR DESTROYING INSOLES</b> PAIR <b>96¢</b>
 <b>SEMICID</b> CONTRACEPTIVE SUPPOSITORIES 20's DOUBLE PACK <b>\$4.32</b>	 <b>DRISTAN</b> DECONGESTANT TABLETS COLDS, SINUS CONGESTION, HAY FEVER 100 <b>\$4.86</b>	 <b>MAALOX PLUS</b> TABLETS 12 TABLETS <b>33¢</b>
 <b>MAALOX PLUS LIQUID</b> LEMON SWISS CREME FLAVOR 12 OZ. <b>\$1.89</b>	 <b>ASCRIPITIN</b> THE ONLY ASPIRIN WITH MAALOX ADDED FOR STOMACH PROTECTION 100 TABLETS <b>\$1.66</b>	 <b>MAALOX LIQUID SUSPENSION</b> 12 OZ. <b>\$1.69</b>
 <b>DRISTAN AF</b> ASPIRIN FREE DECONGESTION TABLETS 100 <b>\$4.86</b>	 <b>DR. SCHOLL ATHLETES FOOT SPRAY</b> 4.5 OZ. <b>\$1.54</b>	 <b>ANACIN</b> FAST PAIN RELIEF 100 <b>\$1.97</b>

Discount Prices EVERY DAY of the Week

1400 SHELDON ROAD-CORNER ANN ARBOR ROAD-PLYMOUTH TOWNSHIP DISCOUNT PRESCRIPTIONS  
 HOURS: Open Monday-Saturday 9 AM - 10 PM Sunday 11 AM - 6 PM  
 PHONE 453-5807 or 453-582R  
 BEER - WINE OR CHAMPAGNE - PACKAGE LIQUOR DEALER

# Bradley tries to get back treasurer position

(Continued from Page 1A)

Her views are tempered by her parents' experience in Communist Romania, where the government confiscated the family's land. "I don't think it should ever have been started," she said of the farmland preservation program. "As far as I'm concerned, it should be dropped. People should be allowed to develop their land. "Anyone who says they don't like open space is not telling the truth. But

we can't infringe on another person's rights to get it. "We put this on the ballot once," she added. "It was voted down." Mrs. Bradley believes local taxpayers will have to pay for a development rights program, if ever implemented. "The people don't want to pay for someone else's land they can't utilize. I'd rather pay for a park I could have a picnic in." Mrs. Bradley envisions eventual de-

velopment in western Canton in "the same way as in the eastern side." She favors revision of the township's zoning ordinance to allow high-rise developments. Current regulations prohibit buildings higher than two stories without special approval. "They want to preserve open space, fine. Then why don't they have high-rises. It isn't like we're on the Gulf of Mexico where we'll be hiding someone's view."

Mrs. Bradley says Canton should build a high-rise housing complex for senior citizens near a shopping center.

**SHE CONSIDERS** industrial development a number-one priority and blames current township attitudes for a shortage of industry. "Developers come here and get degraded by the board. You wonder why they don't turn around and walk out," Kinks in site plans should be worked

out by the time they reach the Township Board, she maintained. "The board makes everything such a major project. We've got to be firm, but we've got to quit being so picky. There's a thing called compromise. We've got to work with these developers."

Mrs. Bradley is all for recreation, "even though I'm not athletic." She suggests construction of a community swimming pool and ice rink with profits from the township-owned Fellows Creek Golf Course. Those monies were earmarked for recreation when the golf course was purchased, she said.

"We've got to keep the youth off the street." In regard to legal fees, she "firmly believes that our tax dollars are going down the drain."

"It seems strange that everything has to go to legal firms," she said. "We have two attorneys on the current board. Can't they give their expertise?"

MRS. BRADLEY believes "some-

thing must be worked out" to pave Warren Road. She opposed construction of the fire station at Warren and Haggerty because of the poor condition. She says ordinance officers should be prohibited from carrying guns. Ordinance officers should fall under the jurisdiction of the police department.

She endorses township steps to establish a farmers market. But Mrs. Bradley opposes operating the market in the New Towne Plaza at Ford and Sheldon. The facility will compete with nearby supermarkets, she said.

"After all, the supermarkets are paying high taxes." Mrs. Bradley campaigned as a running mate of former Supervisor Harold Stein during the last two elections. This time, she is campaigning independently. Mrs. Bradley owns B&K Lawn and Garden Sales on Canton Center with husband George. She worked in the credit and cashier's department of the Ann Arbor Gas Co. prior to 1971. She is a member of the Wayne County Democratic Party, the Plymouth Elks and the Canton Chamber of Commerce.

# Knasiak pushes internal goals

(Continued from Page 1A)

**KNASIAK SAYS** additional policies and procedures are needed to govern day-to-day operations inside township hall.

Better procedures and improved utilization of employees would make Canton's government more cost-efficient, he says.

He says the treasurer should help formulate policies and work "hand in hand" with the finance director on budgetary and other fiscal matters.

"The township has grown from a mom and pop community to a metropolitan of 48,000," said Knasiak. "We have a million dollar budget. Assets should

be protected with procedures on how to handle them.

"I've asked for (current) procedures, and I haven't seen them," he said.

Knasiak criticizes a current practice at township hall to keep a postage meter device unlocked. The machine is located in a room near the back entrance of township hall.

He endorses more accurate record-keeping of business and travel expenses.

"It's just a way of checking to see (if expense policies) are abused," he said.

Knasiak also favors establishment of a "reward" policy for department heads who stay within their yearly

budgets. Increased interest allocations from invested tax money could be awarded to those department heads when budgets are drawn for the following year.

By Township Board action, the treasurer's job will become a full-time position following the November election. Knasiak endorses that decision.

**ALTHOUGH KNASIAK** cites "internal control" as his top priority, he voices concern on other issues — especially "the image of the community."

The Township Board should adopt a program "to clean up the community," he says. Trees and grass should be planted along streets.

"You have to give the homeowners something to see where their tax dollars go. The people are always talking about the image of the community."

"Everywhere you go in Canton is really an ugly sight."

He endorses more funding for recreation and views farmland preservation as an important issue.

In general, however, Knasiak has decided to "shy away from the issues."

"Before you can make a statement, you have to know issues inside and out," he says.

"There's been a lot of talk pro and con (about farmland preservation.) But I can't honestly say I'm for or against it."

"Recreation is a priority item, but not number one," he says. "You can't really prioritize any specific department without making analytical reviews and forecasts."

Knasiak, a Canton resident since 1976, is current president of the Cavalier Village Homeowners Association. He served as a delegate to the Republican Party's state convention last June, at which delegates to the GOP national convention were selected.

# Fire post hangs

(Continued from Page 1A)

the firefighters union, said members of his department want the mechanic in their labor organization.

The Township Board has promised to allocate most of the mechanic's time to the fire department, according to Flodin. But officials want the mechanic available for other township departments.

"We're willing to allow him to work on other vehicles," said Champagne of the union's position. "But we feel that if he's not in the fire union, problems would arise."

The union wants fire department supervision of the mechanic Champagne said.

**NEGOTIATIONS** between the township and firefighters was highlighted publicly last week when two former union officials accused the Township Board of "bad faith bargaining."

Dave Hamilton, former president, and Don Adams, former secretary-treasurer, said township negotiators had not met with them in three weeks.

"If this is good faith bargaining, I don't want to see bad faith bargaining,"

said Adams during the public forum section of a board meeting.

Both union officials lost their office in a union election the following day.

Gorman attributed the lack of bargaining to an impasse on the union membership issue.

"They gave us a proposal we couldn't live with. The board's direction hadn't changed," he said.

According to Gorman, township negotiators met with the union on three separate occasions in May and June. The firefighters contract does not require negotiations regarding newly-created positions, although salary must be negotiated by both sides.

"They asked us to sit down with them, so we did," Gorman said.

Flodin declined comment on the timetable of hiring the mechanic if an agreement between the township and union cannot be reached.

But Champagne expressed an optimistic view on the outcome of bargaining.

"The township seems willing to work with us. There was a stalemate for awhile," he said. "But, hopefully, we can resolve this — rapidly."

**Hallmark Cards**  
for all occasions

**McDevitt**  
478-0707

EASTLAND MALL 6 Mile at Kelly Rd.  
NORTHWOOD CENTER 13 Mile at Woodward

UNIVERSAL MALL 12 Mile at Dequindre  
7-FARMINGTON CENTER 7 Mile at Farmington Rd.

**Aruff's**  
CLEAN FLOOR COVERINGS

HOURS: Daily 10-6  
Mon., Fri. 'til 9

July Clearance Sale  
**BRAIDED RUGS!** in stock  
and 10% OFF all special orders

NORTHVILLE PLAZA MALL  
42337 W. Seven Mile Rd.  
349-3010

**RE-ELECT NOEL D. CULBERT—**  
CANTON SUPERVISOR

• EXPERIENCED • QUALIFIED  
• DEDICATED • EFFECTIVE

**"CULBERT CARES ABOUT CANTON"**

Paid for by Committee to Re-elect Noel D. Culbert, Canton Supervisor, 1706 Woodbridge Ct., Canton, MI 48188

**SALE**

- 20% OFF ALL HANDCRAFTED FURNITURE
- 30% OFF ALL ACCESSORY ITEMS

IN STOCK ITEMS ONLY  
No Credit Cards on Sale Items

**Dick's Pine Crafts**  
878 Starkweather  
"IN OLD VILLAGE" Plymouth  
453-5880

**Portrait Studio, Inc.**

Need a business photograph

In a hurry? Try our **FAST** 24 Hour Service.

- Proofs in 24 hours
- Finished Photos 24 hours after selection

**FOX**

105 N. Center-Northville  
348-0303

We use Kodak paper... for a good look.

**Dearie, Do You...**

Join Us for **OLD VILLAGE'S** 9th Annual **Dearie Days**  
**SATURDAY and SUNDAY**  
**JULY 19 and 20**  
10 - 8 p.m. - Noon - 6 p.m.

OLD FASHIONED BARGAINS • ENTERTAINMENT  
ARTS & CRAFTS • ANTIQUES • CLOWNS • CLASSIC CARS  
WANDERING MUSICIANS • CONTESTS • PONY RIDES

**REMEMBER WHEN**

**HOME IMPROVEMENT \$\$\$ SALE \$\$\$**

ADDITIONS GARAGES  
DORMERS CEMENT  
SIDING AWNINGS  
KITCHENS REPLACEMENT WINDOWS  
BASEMENTS GUTTERS  
ATTICS STORMS-SCREENS

Deal Direct With Owner!  
FREE ESTIMATES

**G CONSTRUCTION**  
453-1590

**the potters wheel gallery**  
689 N. Mill Street  
459-9890 • Plymouth

Selected **Pottery 50% off**  
Saturday Only  
July 19th

**Plymouth Community Band**  
4:00 P.M. Saturday  
Sharps & Flats  
3:00 P.M. Sunday

**Lorraine's Dolls**  
HOSPITAL & TOYS  
Large Selection of Miniatures  
50% Off  
Most Stock  
10% Off  
During Dearie Days Only  
615 N. MILL • 459-3410  
(corner of Spring Street)

**House of GLAMOUR**  
Visit our **OUTDOOR PARLOR**  
**HAIRCUTS \$6.50**  
Reg \$12.00  
No Appointments Taken  
also  
Beard & Mustach Trims  
630 STARKWEATHER  
453-8254

**VILLAGE PAPERBACK EXCHANGE**  
10% OFF TUPPERWARE

**USED PAPERBACKS HALF PRICE or 49¢**  
WITH A TRADE SELECTED BOOKS 10¢

**OVER 23,000 BOOKS TO CHOOSE FROM**  
ALL VOLUMES INCLUDE RECENT BEST SELLERS

819 N. MILL  
PLYMOUTH • 459-8550

**Plymouth METAL DETECTORS**

**FREE \$14.95 Vinyl Carrying Case** with Purchase of **JUDGE 2 or 6** & RM7 or Coin Magnum

578 STARKWEATHER  
PLYMOUTH, MICHIGAN 48170

**20% Off All Lapidary Machines and Ready-made Jewelry**  
(313) 459-0375

**In The Old Village, it's BILL'S MARKET**

- Groceries & Meats
- Sandwiches
- Delicatessen
- Party Snacks
- Beer & Wine (TO TAKE OUT)

Dearie Days Special EGGS 35¢ DOZ.

Free Parking

584 STARKWEATHER • PLYMOUTH  
453-5040  
OPEN 7 DAYS A WEEK HOURS: 7:30-9:30 P.M.

**Village Square Outlet**  
**30% Off EVERYTHING**  
**75% Off One Rack of Misc.**

**Nikki of Carolinas**  
Sizes 8 to 46  
615 N. MILL • PLYMOUTH 459-1230  
Hours: Mon.-Sat. 10-5

The Special Place to Shop in Plymouth

# BREVITIES



**BREVITIES DEADLINES**  
Announcements for Brevities should be submitted by noon Monday for the Thursday edition and by noon Thursday for the Monday edition. Bring in or mail to the Observer at 461 S. Main, Plymouth 48170.

**PRESELEY'S CAR SHOWN**

July 17-18 — The car once owned by Elvis Presley will be on display from 9 a.m. to 9 p.m. at Don Massey Cadillac on Ann Arbor Road just west of I-275. As part of the display Dave Falzetti and "The Celebration" will be performing from 7-10 p.m. July 17. Public welcome.

**LEADER DOG SALE**

July 17-19 — Friends of Leader Dogs will hold a garage sale from 10 a.m. to 6 p.m. each day at 20037 Indian, Redford Township south of Grand River and east of Inkster Road. There will be appliances, Avon bottles, baby items, children's and adult clothing, furniture, original art, plants, toys, and other items.

**CONCERT IN PARK**

July 24 — "Two on the Aisle" is the theme for the Concert in the Park starting at 8 p.m. July 24 in Kellogg Park in downtown Plymouth. Bring lawnchairs or a blanket. Concerts are free and open to the public.

**TORONTO WEEKEND**

Aug. 25-27 — A deluxe Toronto weekend is open to all senior citizens,

55 and older, Aug. 25-27. Rates are \$89 double occupancy per person and \$129 single occupancy per person. Round trip includes party bus, two nights at the Sheraton Hotel plus all extras. Mail check to Corporate Travel, c/o Timothy Burch, 23527 Ford Road, Dearborn, Mich. 48128, or call Irene Murphy at 397-1000, ext. 278, at the office or at 453-3379 at home.

**FRIENDS OF LEADER DOGS**

The Friends of Leader Dogs, an organization which works to raise funds for the Leader Dog School for the Blind in Rochester meets on the third Monday of each month at Beverly Hills United Methodist Church, 20000 W. 13 Mile at Evergreen (northeast corner) at 10 a.m. Guests welcome.

**GERMAN-AMERICANS**

July 17 — The German-American Club of Plymouth will start its meeting promptly at 8 p.m. in the Oddfellows Hall at 344 Elizabeth, Plymouth. Final plans will be made for the annual picnic on July 20.

**ISBISTER SCHOOL FAIR**

July 18 — Isbister Elementary School will have its annual Fun Fair from 5-9 p.m. at the school at 9300 Canton Center Road, Plymouth. Featured will be a moon walk, prizes (including a 19-inch color TV and an AM-FM stereo recorder), food, pop, a bake sale, a number of games and a dunk tank. Tickets will be sold at the door. Everyone welcome.



## New architecture?

A large section from a tree that snapped under the fury of Wednesday's storm waits to be cleaned up from a yard at the corner of Maple and Kellogg. This scene was repeated in several locations throughout the city. (Staff photo by Bill Bresler)

# SUNDAY KIDS EAT FREE\*

Gather up your family and bring them down to Holly's By Golly. We'll feed your children free.

\*One Kid's Meal FREE (from Children's Menu) with the purchase of a regular adult meal. Desserts not included. Offer good for kids 12 years and under.



The Family Restaurant & Pub

1020 W. Ann Arbor Road, Plymouth, MI 48170. 518/459-4190

## Collins elected

Dan Collins of Plymouth has been elected president of the Association for Retarded Citizens (ARC) Northwest Communities.

Other officers include: Carol Humphrey of Redford, vice-president; Jean Berry of Plymouth, recording secretary; Sherri Beck of Detroit, corresponding secretary; LeRoy Stegen of Livonia, treasurer.

New board members of ARC include Edward Hibner of Plymouth, Rob Moore of Livonia, Mary Louk of Livonia and Carol Zago of Livonia.

ARC is a volunteer non-profit membership organization. The group depends on its own fundraising activities, a small grant from United Foundation, and private donations to provide programs for mentally retarded persons who live in Plymouth, Livonia, Redford, Northville and Garden City.

Persons with questions or who would like to become a member may contact Margaret Olesnavage at 937-2360.



daryl L. howell, d.p.m.

Medical & Surgical Foot Specialist  
Newburgh Heights Medical Village  
(corner of Glenwood & Newburgh Rd.)  
37382 Glenwood • 728-4300  
Saturday & Evening  
Appointments Available

Most services covered by Medicare, Blue Cross-Blue Shield or Private Insurances.

**NORTHVILLE FLOOR COVERING**  
140 Mary Alexander Ct.  
Northville - 348-8010  
SALE ON ORIENTAL STYLE RUGS  
Tile  
Linoleum  
Carpet  
Custom Installation

## H & B GALLERY OF FINE CARPETING

# LEES Grand Opening SALE

Special values now on selected quality Lees Carpets of all textures, styles, and colors with tremendous savings and ready for immediate installation. Savings that you won't believe.

## SAVINGS

**15 to 30%**

## at our NEW LOCATION

This means \$3<sup>00</sup> - \$4<sup>00</sup> - \$5<sup>00</sup> Off List Price per yard on selected group of carpeting.  
Expert Installation

Hurry! Sale ends Saturday!  
July 31, 1980



## Schrader's Summer Home Furnishings

# SALE

SAVE UP TO **50%**

- All Merchandise in Store on Sale
- Special Orders Taken at a Sale Price
- Prompt and Courteous Free Delivery
- Convenient Credit Terms Available
- Get our Price Before You Order

## Schrader's Home Furnishings



"Since 1907"

111 N. Center (Sheldon) Northville  
Phone 349-1838  
Hours through July  
9 to 9 - Mon., Tues., Thurs., & Fri.  
9 to 6 - Saturday  
Closed Wednesday

## H & B Gallery / Carpeting

637 MAIN STREET  
(1 BLK. S. of MAYFLOWER HOTEL)  
PLYMOUTH  
(Formerly Anderson Music)

459-5040



# Wagons Ho!

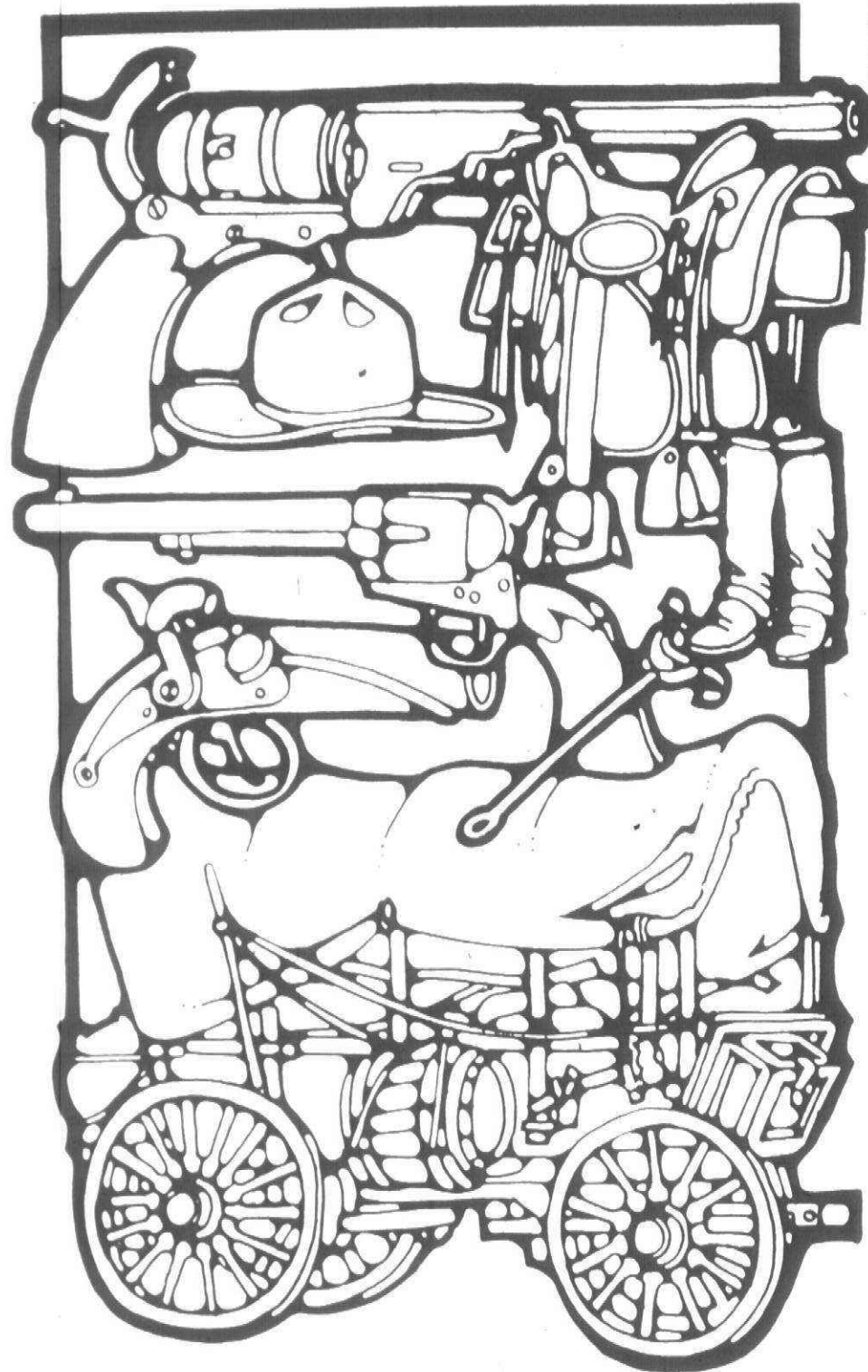

## Western Bargain Days

SIDEWALK SALE JULY 17, 18 AND 19  
 Each Day - Paul Webbs Country Western Band  
 1-7 P.M.  
 July 17 & 18 - In person - Deano Day 1-3 P.M.  
 July 19 - R.T. Griffin, WCXI - 3-5 P.M.  
 Jimmy Bare, WSDS 11 A.M. - 6 P.M.  
 Rick Hamilton CKLW-FM 3-6 P.M.  
 "Free Hats" for the Kiddies (while they last)  
**July 19 - Saturday 4 P.M.**  
**Dolly Parton**  
 &  
**Kenny Rogers**  
**Look-a-like Contest**  
 (on stage near the Sears pool)  
 "Guess the Beans" contest at Crowley stage.  
 Winner guessing the exact amount (or closest  
 to that amount) will win a side of beef.

# Makeup!

## Republicans put their best face forward

By NORMAN PRADY  
 Can a pat on the cheek help someone become president? On the chance that it might, the Republicans in town are making use of the services of Carolyn Kerner Stein of West Bloomfield.

With powder puffs loaded and ready to billow, she's stationed near the podium in Joe Louis Arena. Her job is to make sure Ronald Reagan and other notable Republicans put their best faces forward.

Mrs. Stein is a makeup artist. She was recommended to the GOP by a New York television producer.

Her assignment, she explains, is not to create deceptions about anyone's appearance, but to help people defend themselves against the harshness of the lights, the questionable sensitivity of the cameras and the visible strain of the event.

"CORRECTING THINGS the camera would pick up," Mrs. Stein calls her job. But if you happen to be a Republican with a double chin, she has kits filled with topical potions that are faster than plastic surgery.

Considering the popular theory that Richard Nixon's appearance during the Nixon-Kennedy debates was a factor in his losing that election, Mrs. Stein hopes people "pay more attention to fundamentals" and vote for more than looks.

But the lesson politicians learned from those telecasts was to not wear clothing that blends into the background and to do something about a heavy-looking beard.

"Nixon looked pale and drawn and needed some makeup to help him look tanned and robust," she says. "It was near the end of the campaign and I'm sure he was very tired."

POLITICAL POWDERING is simple for Mrs. Stein compared with some work she's done. She recently was hired to give an actor a Karl Malden nose, a challenge possibly met successfully before only by Malden's parents.

She also is prepared to give any actor whatever

bruises or disfigurements a script might call for, and wounds to match any weapon.

In somewhat less extreme categories, she makes people up for television commercials, talk shows and movies. She's done Detroit's top auto people, athletes, entertainers and a number of Miss Americas.

Her list includes Muhammad Ali, Billie Jean King, Van Johnson, Hugh Downs, Ricardo Montalban, Victor Borge, Jane Wyatt and E.G. Marshall.

She made up the stars of three made-in-Detroit feature films: Sterling Hayden in the never-released "Michael"; Richard Pryor in "Blue Collar," and Laurence Olivier in "The Betsy."

OLIVIER, HERE PRIOR to being named Lord Olivier, was very cordial, she remembers. "When you finally meet him, you don't know if you're going to bow or faint. I finally said, 'Hello, Sir Laurence,' and he smiled and said, 'Call me Larry.'"

In addition to GOP duties, Mrs. Stein has been hired by the Foreign Broadcasting Service for special assignments. CBS - Walter Cronkite & Co. - also has hired her to aid their own makeup staff.

Security clearance by the Secret Service was a prerequisite to getting the job. She wears on a neck chain the scarce pass that gets her to the podium area.

That's where she was scheduled to face the faces of such unordinary folk as Pat Boone, Glen Campbell, Mayor Young, Billy Graham, Gov. Milliken, President Ford, Susan Anton, Vicki Carr, Buddy Ebsen, Chad Everett, Wayne Newton, Ginger Rogers, Jimmy Stewart, Barry Goldwater Sr. and Jr., John Connolly, Henry Kissinger, George Bush and Howard Baker, among others.

It's also likely that she will see the vice presidential candidate, whoever he is going to be, before the rest of the world does.

As with the presidential candidate, the plan is that before anyone else sees him, Mrs. Stein will tuck paper towels into his collar and ask him to close his eyes.



WEST BLOOMFIELD'S CAROLYN KERNER STEIN

PRICES CUT AGAIN  
 IN OUR SEMI-ANNUAL  
 SHOE  
 CLEARANCE!  
**BAKERS**  
 QUALICRAFT SHOE STORES

ORIG. 12.99 TO 15.99

**4.98**

ORIG. 16.99 TO 21.99

**5.98**

ORIG. 22.99 & MORE

**6.98**

- Select groups, all from regular stock!
- Broken sizes but whopping selections!

Redhot Handbag Bargains, Too!

Intermediate reductions have been taken

Master Charge • Visa  
 LIVONIA MALL STORE ONLY

**ACME ACTION GEAR**  
**ODDS & ENDS**

In addition to these specials we have a large assortment of other sporting goods available at below wholesale prices!

(Famous names)  
**ATHLETIC SHOES**

Values to \$15 Values from: \$15-\$20 Values over \$20

now \$5 pr. now \$6 pr. now \$7 pr.

(Ebonite, Brunswick and others)  
**BOWLING SHOES**

Values to \$14 from

now \$3 pr.

**ASSORTED ATHLETIC SHIRTS** now \$2 and up

**LIGHTWEIGHT NYLON JACKETS** now \$4

**ASSORTED BASEBALL HATS** now 75¢

Sale ends July 19. All sales final. Taxes limited.

**ACME SPORTING GOODS**  
 LIVONIA MALL  
 7 mile, west of Middlebelt  
 478-8810

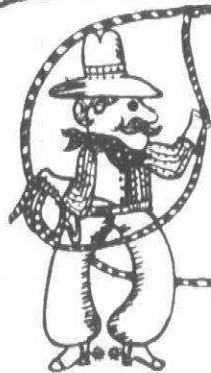

# YEEHA!

Giddap over to Crowley's for a real barn buster of a sale during Livonia Mall Western Bargain Days! Thursday, July 17 thru Saturday, July 19.

**SAVE 25% to 50%**

- Off the original prices on
- WOMEN'S APPAREL
- FASHION ACCESSORIES
- LINGERIE
- MEN'S WEAR
- CHILDREN'S WEAR
- HOME FURNISHINGS
- HOUSEWARES
- AND MUCH MORE!

*Crowley's*

Livonia Mall open nightly til 9 p.m. and Sunday noon til 5 p.m.



Livonia Mall  
 Card Shop Inc.

WELCOMES YOU  
 TO IT'S  
 "WESTERN DAYS"  
 SIDEWALK SALE

Bargains Include:

Lenox Candles  
 Scented Columns and Tapers  
 NOW 1/2 OFF

Discontinued Hallmark

- Party Goods
- Stationery
- Playing Cards and Key Chains

1/2 OFF

Come In and Browse.  
 Sears Court 476-6837

**Livonia Mall**  
 The neighborly people at your neighborhood Mall  
 Seven Mile and Middlebelt Road

# Downtown's working stiffs join the party

By JUDITH BERNE

Downtown Detroit during the Republican Convention is turning out to be a party for both conventioners and those who normally work downtown.

"I think we have the best of both worlds," says Rick Kaye, a West Bloomfield resident, whose 29th floor office in the Renaissance Center overlooks Detroit.

"There've been none of the inconveniences everyone expected, but all of the excitement."

Kaye, a partner in the international accounting firm of Coopers and Lybrand, confirms reports of little traffic and half empty restaurants.

"Traffic is better than usual. I went to get gas in Windsor. No one was there. Everything's been empty."

He acknowledged that many of the people he works with were concerned that the convention would complicate their work routine.

"One guy in our office deliberately took this week off," Kaye said. "He didn't want the hassle."

DURING THE first two days of the convention, Kaye shook hands with Ronald Reagan, walked alongside former Secretary of State Henry Kissinger and spied U.S. Senators Howard Baker and Robert Dole. Kissinger, he said, was surrounded by "seven or eight Secret Service men."

He enjoys the knowledge that NBC's Today show is being filmed below him and watched from his high perch the white-robed procession of ERA marchers head down the riverfront to the Joe Louis Arena.

As partner in charge of the actuarial, benefits and compensation consulting services, he talks to people from other areas of the country. "They're all asking how it is here," he said.

He tells them, "It's exciting. Delegates are all over. I'm going out of my way, as others do, to be helpful."

Renaissance Center-based firms, such as Coopers and Lybrand, asked for company volunteers to give special help to delegates and other out-of-towners. They wear red badges asking "Can I help you?"

THE FRIENDLINESS of Detroiters such as those who work in the Renaissance Center and the overall organization of the convention has left conventioners such as Debbie Goodell and Chris Hutchens, from Colorado, thoroughly impressed with Detroit and its suburbs.

Ms. Goodell, 19, paid her own way to be a page at the convention. Ms. Hutchens, 20, is an official convention visitor. Both are staying at the Holiday Inn in Southfield.

"I was expecting something totally different," Ms. Goodell said. "I was expecting to see a lot more chaos. People are so friendly."

"It seems like the whole state has gone out of their way to help with the GOP convention."

Both women say transportation between Southfield and the convention area has been no problem, with buses leaving the motel every half hour.

A party for the Colorado delegation at the Bloomfield Township home of Oakland County Circuit Court Judge Hilda Gage and her attorney husband, Noel, got their four-day visit off to a good start.

And although Michiganders travel to Colorado by the droves for scenery, Ms. Hutchens said, "Everything's so green here. We're not used to so many trees."

# GOP delegates snap to attention

By ALICE COLLINS

One man single-handedly brought the entire Republican National Convention to a dead halt Tuesday night.

Doug Ashley of Bloomfield Township got on top of the ABC Television anchor booth, leaned over and shot the official GOP convention photograph.

Interviewed while he was still testing and preparing to take the historic picture, Ashley said he didn't intend to be nervous, even at the crucial moment.

"We've been making test photos all week from a number of positions," said Ashley. "We're ready."

Working with him are his wife, Janet Ashley, also a free lance photographer, and Robert Moore Jr., a colleague from Warren.

Ashley said about the plum assignment: "I'm absolutely ecstatic."

How does a free lance photographer become the official GOP convention photographer?

"I WAS originally retained by the people in charge of building all of the convention facilities (Greyhound Exposition Services)," said Ashley. "They asked me on behalf of the GOP National Committee to come up with a photo history of the convention."

Ashley began shooting during the first week in June and has followed it through.

"The national committee asked me to take the official photo two weeks ago," he said. "While I've done many major events and many political conventions, this is the first one I've been through from the ground up."

"And it's the first time I've had a whole convention grind to a halt for me."

Ashley is using about \$7,000 worth of equipment, he said. Test shots for the official photograph were taken from several spots in the Joe Louis Arena and submitted to the committee for selection.

Ashley's being on the spot has led to many other assignments connected with the convention, including a photograph for a national NBC-TV advertisement and photo coverage of private and public receptions and parties.

He's also shooting the convention for American Youth Magazine and newspapers in the Flint area.

ON MONDAY NIGHT he took what he calls a "fish-eye" photo, a panoramic view of the entire arena, from the catwalk in the ceiling at the request of Michigan Lt. Gov. William Brickley.

Ashley, a professional photographer since 1959, works out of his home in the township. He has covered every Republican national convention since 1960 and most Democratic national conventions.

He is director of photography for the Silverdome in Pontiac and director of public relations for the National Press Photographers Association.



Downtown Detroit regulars are getting into the act, enjoying the Republican convention and all the sights and sounds and fun that accompanies it. This was the scene earlier in the week on Hart Plaza. (Photo by Randy Borst)

# It's out of this world: Westland's Sidewalk Sale.



JULY 18, 19 & 20

The bargains move into the mall this weekend! It's Westland's Sidewalk Sale, and the savings will put you on cloud nine. You'll find summer fashions for every member of the family. Things for your home. Gifts. Sporting goods. Something from virtually every store—drastically marked down.

And there's more: Friday at 11 a.m., 2, 4 & 7 p.m. Russ Vogel's "The Beast" entertains the kids in the Central Court. Saturday, Hee Haw's Roni Stoneman sings her country-western best at 11 a.m., 2 & 7 p.m. in the Central Court. And Sunday, enjoy the Renaissance Brass Quintet at 2 & 3 p.m. in the Central Court.

Don't miss the fun, or the Sidewalk Sale. It's out of this world!

## On the level, we've got it all.

**Westland**  
C E N T E R

Wayne & Warren Rds.—Westland

## Conservatives love it

# Kissinger talks tough about Reds

By STEVE BARNABY

Political observers betting on an anti-Henry Kissinger rally during the former secretary of state's address to the GOP convention ended up in the red.

After having met earlier this week with Republican presidential nominee Ronald Reagan, Kissinger sauntered to the podium and delivered a hard-line professorial lecture on foreign policy.

Instead of being harassed by delegate jeers, the Nobel Peace Prize winner was greeted with a standing ovation.

Before the GOP gathering in Detroit, many conservatives had objected to Kissinger addressing the convention.

Kissinger has been considered by many Republican conservatives as being "too soft" on Communist nations with his policy of detente and endorsement of the Panama Canal and Salt II treaties.

Most feared a repeat of the 1964 GOP convention when Barry Goldwater supporters refused to allow New York Governor Nelson Rockefeller to finish his speech.

At one time Kissinger served as Rockefeller's foreign affairs advisor and is considered to be a member of the moderate Republican faction.

But Reagan, who throughout the campaign has insisted on a

show of unity before national network cameras, got just what he wanted.

THE GEORGETOWN UNIVERSITY professor was anything but too soft when it came to criticizing the Carter foreign affairs policies.

"After nearly four years of confusion we have become impotent bystanders as the world lurches from crisis to crisis," he told the late-night gathering.

"The Carter administration has managed the extraordinary feat of having at one and the same time the worst relations with our allies, the worst relations with our adversaries and the most serious upheavals in the developing world since the second World War."

Kissinger labeled Carter foreign policy as naive and as a philosophy of "abdication."

He swept through the litany of what he considered to be Carter transgressions: vacillation on the neutron bomb; a barometric defense budget; acceptance of Soviet troops in Cuba; the Afghanistan invasion; and, of course the Iranian hostages.

"The neglect of our defenses has tempted mounting threats to our national security," he warned.

Carter policy endorses the use of "cynical expedients to get

through the election."

"We are told endless alibis for doing nothing; that not every upheaval affects our interests, that the disasters have complex socio-economic causes, that Communist gains will prove temporary," he said.

KISSINGER who would very much like to rejoin a national administration offered his own solutions.

- Rebuild military defenses.
- End Soviet expansionism.
- Mend alliances.
- Work with persons of "good will" around the world to fulfill mankind's positive aspirations.

"Sooner or later our weakness will produce a catastrophe. The time is too serious to play a numbers game with our defense budget," he said, insisting that the gap in military spending between the Soviet Union and the United States be closed.

In traditional Kissinger philosophy, he called for a restoration of the political balance of power.

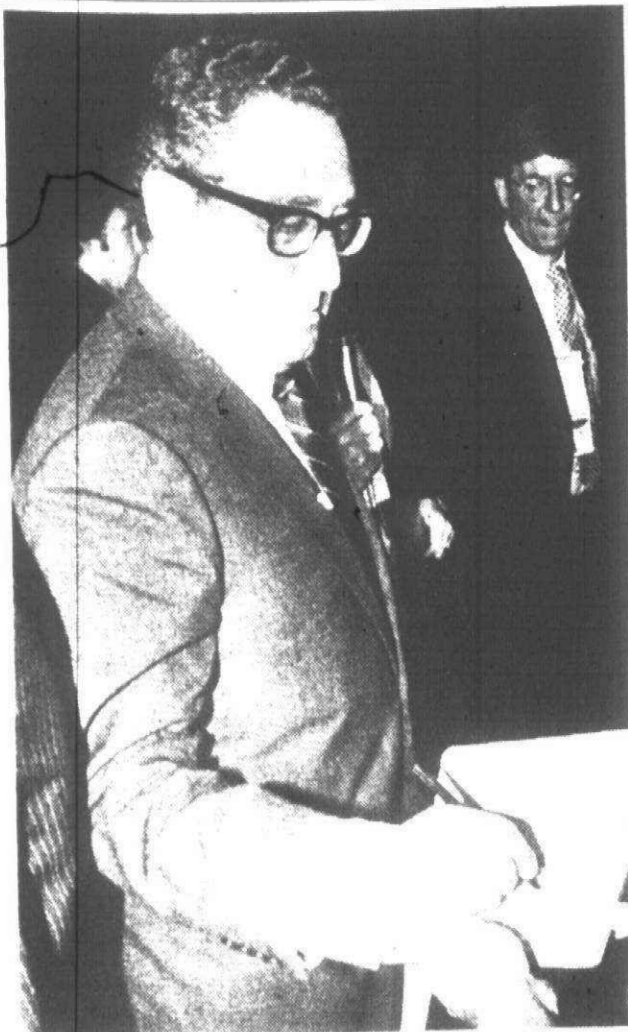

## SNAP SHOTS

It's hard to describe the reception U.S. Rep. Carl Pursell and former Sen. Robert Griffin threw Sunday at Greenfield Village for Republican congressmen attending the GOP National Convention.

Working the group for all three hours was a hand-shaking George Bush, whom Pursell, R-Plymouth, had supported for the presidential nomination.

Since Bush quit the race May 26, Pursell had openly pushed the former ambassador as Ronald Reagan's running mate.

Bush was in more snapshots than anyone. Stars of the show, based on applause, were Gerald and Betty Ford. The former president and first lady made a 10-minute appearance and then were whisked off by helicopter from the brunch hall.

Two famous names from the 1972 primaries were at the Pursell-Griffin bash.

Rep. Pete McCloskey, the ex-Marine from California who had challenged Richard Nixon for the presidential nomination on an anti-war platform, was there from the liberal side of the spectrum.

Rep. John Ashbrook, the conservative Ohioan, was there to present the now-dominant right wing which also challenged Nixon.

Chuckled Pursell: "We try to keep the party broad-based."

"Sonofagun!" said Rep. Don Clausen of California after the party. "We forgot to get the best photo of the day. We could have had four first basemen."

Clausen, once a semi-pro ballplayer, explained that Ford, who had served in the House from 1949-73, had been first basemen on the House Republican softball team.

Bush, who served from 1969-72, also had been first basemen Pursell, elected in 1976, is the current first basemen.

Clausen himself had played first sack between the times Ford, Bush and Pursell had performed, saying he voluntarily surrendered the post when a better player came along.

"We won all but four of the last 17 games," Clausen said. "It proves a point. If Republicans can have the same number of players in a game, we can do extraordinarily well."

Currently Democrats outnumber Republicans about 2-1 in Congress.

Clausen added that Pursell "has immense respect on both sides of the aisle" and that the second-term Michigan congressman is on his way to becoming a national figure.

"I could be with my delegation (at the Detroit Plaza) Hotel," said Clausen. "I'm senior member of the California Republican congressional delegation. But I chose to be here at Carl's affair."

Alice Haidostian of Birmingham was at the brunch for several reasons.

She performed at the piano - works ranging from "Sunny Side of the Street" to "The Victors," when her fellow U-M grad Ford entered.

Another reason was that Pursell's staff did most of the work for the party, and her daughter, Cynthia Hudgins, works in Pursell's Ann Arbor district office.

Jack McDonald was there. The congressman from the old 19th District from 1967-72, he now heads Jack McDonald Associates, a lobbying firm in Washington, D.C.

The former Redford Township supervisor and Farmington Hills resident went into lobbying after losing the congressional nomination to veteran Rep. William Broomfield of Birmingham following the 1970 census. Broomfield also attended.

Among McDonald's clients are American Express, Burroughs Corp., Dow Chemical, Northrup Aviation, Mutual Benefit Insurance Co., the National Association of Life Underwriters - and Japan.

"I've been doing some economic counseling on trade matters," McDonald said.

Is it tough to represent Japan at a time when Japanese auto imports are under political attack? "No, it's easy because the administration's policy and Japan's are the same."

McDonald added he does some national party work and "handle some things for members of Congress."

There's a new public policy firm in Washington called Esch Associates.

At the Pursell brunch was its principal, former U.S. Rep. Marvin Esch. Pursell won the 2nd District seat when Esch vacated it in 1976 to run unsuccessfully for the U.S. Senate.

After that election, Esch was a vice-president of U.S. Steel but since the first of the year has been in his own firm.

"We analyze public policy issues for associations or large corporations, seeing what issues will impact on them in the next five to 10 years."

Clients include U.S. Steel, a metals company and associations in the communications field, the one-time U-M speech professor said.

## WESTLAND SIDEWALK SALE - JULY 18-19-20 FOR FASHION, EXCITEMENT, AND VALUE

### WESTLAND SIDEWALK SALE Entertainment

FRIDAY

JULY 18 - 11 a.m., 2 p.m., 4 p.m., & 7 p.m.

CHILDREN'S SHOW - "THE BEAST"

SATURDAY

JULY 19 - 11 a.m., 2 p.m., 7 p.m.

HEE HAWS RONI STONEMAN

SUNDAY

JULY 20 - 1 p.m., 2 p.m.

RENAISSANCE QUINTET

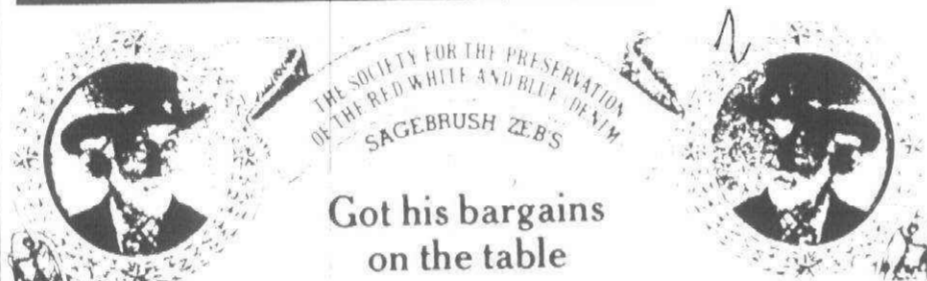

**Levi's**  
**MEN'S FASHION  
SLACKS**

Regularly \$18-\$24.  
Assortment of styles and colors - but, hurry! At this price, they won't last long.

**11<sup>99</sup>**



• In Westland Mall only

**Levi's**  
**WOMENSWEAR**

**TOPS AND  
BLOUSES**  
**\$5 to 19.99**

Regularly \$25-\$30.  
Juniors and Misses sizes in assorted fabrics.

**JEANS &  
SLACKS**  
**11.99 to 19.99**

Regularly \$18-\$28.  
An unbelievable savings on high-quality fashions by Levi-Strauss.

PRICES GOOD THURSDAY, JULY 17  
THRU SATURDAY, JULY 19, 1980

**Brilliant Jewelers  
Sidewalk Sale Special**

**35% OFF**

**ALL WATCHES**

SEIKO, CITIZEN, LONGINES, BULOVA

Westland Shopping Center  
Lower Level  
425-0960

Select Grain Fed  
**CENTER CUT**  
**PORK CHOPS** \$1<sup>59</sup> LB.

**FREEZER BEEF SPECIAL**  
USDA CHOICE  
**SIDE \$1<sup>49</sup> LB.** **FRONT QTR. \$1<sup>17</sup> LB.**

Fresh BBQ Ready!  
**CHICKEN LEGS** w/back portion  
Only **59¢** LB.  
Expires 7-19-80

**100% Lean Beef Hamburger**  
**QUARTER POUND PATTIES**  
**\$1<sup>29</sup> LB.**  
GROUND CHUCK PATTIES \$1<sup>99</sup> LB.

**WESTLAND MEATS, INC.**  
featuring Alexander & Hornung products  
**Westland Center 421-2730**  
Mon. & Thurs. 9:30-8 Tues. & Wed. 9:30-6 Fri. & Sat. 9:30-8

**RECORDLAND**

BUY ANY L.P. or TAPE  
at **\$6<sup>99</sup>** or over  
and receive  
**\$3<sup>00</sup> OFF**

2nd L.P. or Tape \$6.99 or over  
**PLUS:**

- Selected tapes \$4.98
- 100's of titles to choose from
- 2 for 1 Poster Sale  
Buy one get second free
- 20% OFF All Carrying Cases

July 18, 19 & 20th ONLY!  
YOUR FULL SERVICE RECORD  
AND TAPE STORE

BLANK TAPE (TKD, MAXELL, BASF, MEMOREX, BLANK VIDEO, RECORD CARE PRODUCTS, POSTERS, 45's, ACCESSORIES AND MORE.

LOWER LEVEL PH. 422-5840

**recordland**

WESTLAND located in the Lower level 422-5840

Also located in Twelve Oaks Mall, Novi and Briarwood, Ann Arbor



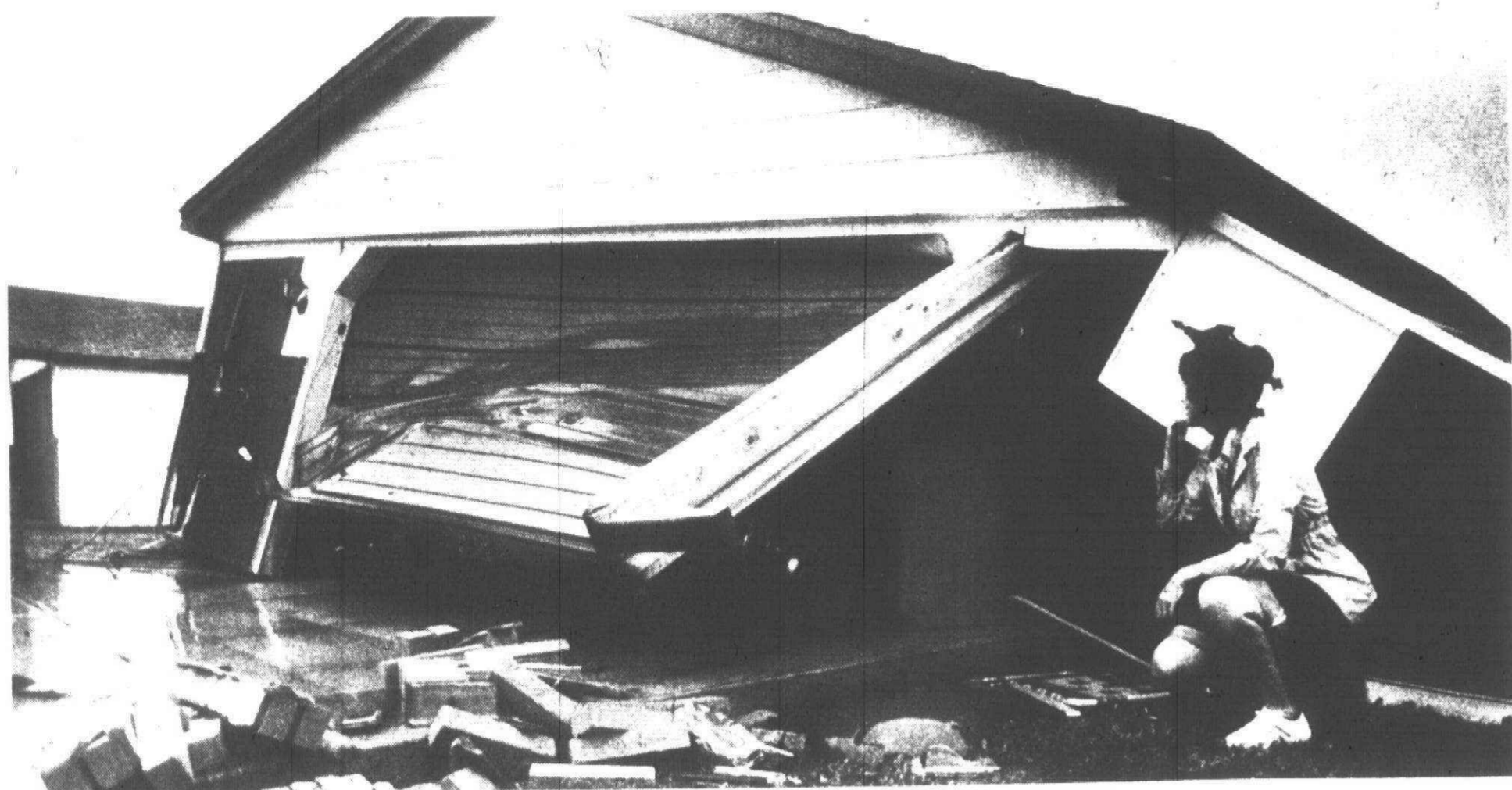

Gloria Timberman surveys the damage done to her garage and car by a storm that swept through Canton Wednesday morning. (Staff photo by Bill Bresler)

## Officials give advice in wake of bad storm

Canton Township officials are reporting the following list of instructions in the wake of the storm Tuesday morning which uprooted trees, smashed windows and garages and blanked electrical and telephone service.

- **Fallen wires:** Don't touch any wires. Call Detroit Edison for repair service.
- **Power off:** Shut off main breaker until power is restored.
- **Water:** Drinking water is available at pumps in front of the DPW building on Geddes west of Sheldon, and on Canton Center Road south of Warren.
- **Emergency service:** Use the emergency fire number (981-1111) only for true emergencies. For other questions or service, call the township hall at 397-1000.

• **Fallen trees or branches:** Place all tree limbs in a location that is accessible to trucks.

• **Dump:** The dump on Lilley south of Michigan is open from 9 a.m. to 5 p.m. weekdays, and from 9 a.m. to noon Saturday.

• **Food:** Emergency food may be obtained from the Canton Goodfellows. Call Jerry Bodenmiller at 397-1561.

• **Restrooms:** Public restrooms at the township hall on Canton Center Road are open from 8:30 a.m. to 5 p.m. weekdays.

Additional restroom locations are the police station on Geddes and Herbey, and Canton fire stations.

The fire stations are on Cherry Hill and Canton Center Road, and on Warren east of Lilley. Restrooms also are available in Meijer's Thrifty Acres on Canton Center Road.

# WESTLAND SIDEWALK SALE — JULY 18 - 19 - 20 FOR FASHION, EXCITEMENT, AND VALUE!

## Sidewalk Sale

**50% Off  
Selected Sale  
Merchandise**

Terrific savings on maternity fashions:  
Tops • Pants • Dresses... and more!  
Come early for the best selection

**MOTHERHOOD  
Maternity Shops**

Over 300 locations across the country

**WESTLAND CENTER**

## CIRCUS WORLD

The Toy Store in the Mall

**SIDEWALK SALE**  
We've cleared our shelves...  
SAVE ON HUNDREDS OF FANTASTIC TOYS!  
SOME REDUCED AS MUCH AS

**50%-60%-70%**

ALL ITEMS OFFERED FOR SALE ARE GREATLY REDUCED. REDUCTIONS FROM REGULAR PRICE. RANGE FROM 20% TO 70%.



**WESTLAND CENTER  
PHONE 261-6230 WESTLAND**

## Sidewalk Sale!

**Don't Miss Our  
SEMI-ANNUAL  
1/2 OFF CLEARANCE SALE**

Select from a wide variety of white and summer colors, and tailored jewelry including all of our famous brands. You will be amazed at the large variety that you can still find at 99¢ to \$4.99 at your Fashion Jewelry Store

**corey's  
jewel box**

WESTLAND CENTER

# SALE

save up to  
**50%**

**On Famous Maker Tops and Bottoms**

Levi's  
Brittania  
French Star  
Male

Disco  
Kennington  
Sundowner  
Campus

**Huge Selection of Denim Jeans  
Lots of Tops and Bottoms for Gals**

**THE BOTTOMHALF**

WESTLAND CENTER

**SHOP  
AND  
SAVE  
AT  
WESTLAND**

PRICES CUT AGAIN  
IN OUR SEMI-ANNUAL  
SHOE  
CLEARANCE!  
**BAKERS**  
QUALICRAFT SHOE STORES

ORIG 12.99 TO 15.99  
**4.98**

ORIG 16.99 TO 21.99  
**5.98**

ORIG 22.99 & MORE  
**6.98**

- Select groups, all from regular stock!
- Broken sizes but whopping selections!

**Redhot Handbag Bargains, Too!**

Intermediate reductions have been taken.

Master Charge • VISA

WESTLAND CENTER

## Bono's 5th Annual CHRISTMAS IN JULY SALE!

July 16th - 25th

**20% To 50% OFF  
ON ALL  
MERCHANDISE**

**jiffy  
Cstitchery**



Now is the  
time to start  
your Christmas  
gifts and  
Christmas  
Ornaments.

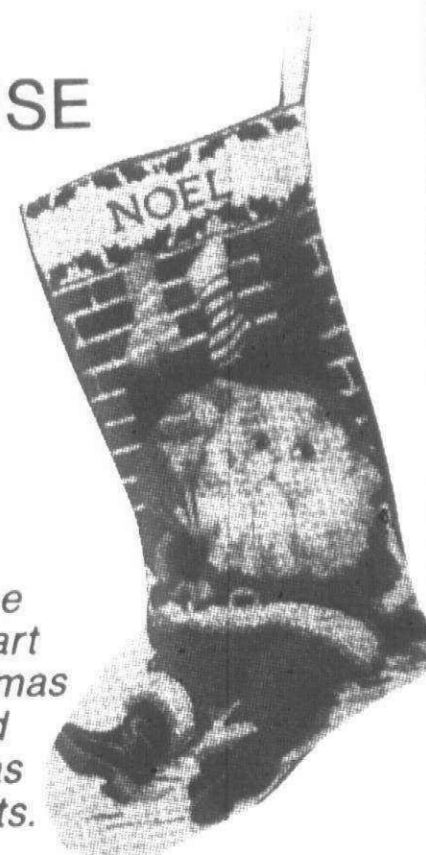

**BONO'S**

NEEDLECRAFT • ART • HOBBY SUPPLIES  
WESTLAND SHOPPING CENTER

LOWER LEVEL

525-5230

# JCPenney Sidewalk Sale Days

## July 17, 18 and 19, J. C. Penney Westland Only

**Men's and Women's Warm-Up Suits**



**Sale 10.99**

Orig. \$19.99 to \$24.99. Men's and women's warm-up suits in assorted looks. Some have pullover tops, some have zip fronts, most are of acrylic knit. Solids with contrast trim. Most sizes. Only 200 units to sell.

**J. C. Penney Westland Only**

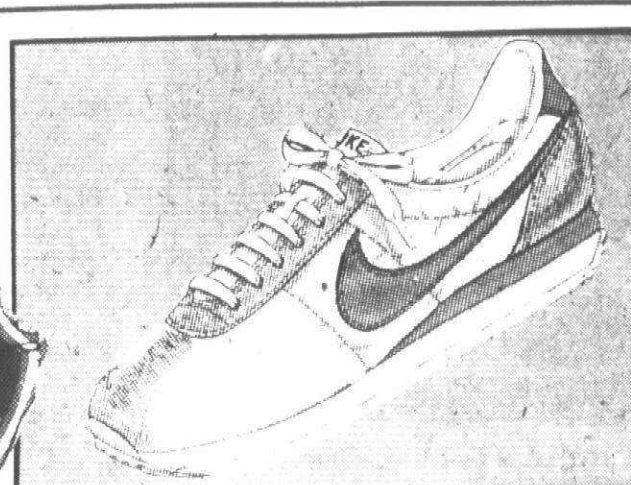

**Great buy Nike Waffle Trainer Sale 10.99**

Orig. \$29.99. Ladies Nike Waffle trainer athletic shoe. Features nylon suede upper with patented waffle sole. Yellow and blue, most sizes. A total of 225 units to sell.

**J. C. Penney Westland Only**

**Car Floor Mats Special 6.99**

Four piece set with 2 front and 2 rear broadloom floor mats.

Only 192 to sell.  
**J. C. Penney Westland Only**

**33 1/3% Off**

Selected in-stock air conditioners.

**J. C. Penney Westland Only**

**Tennis Rackets**

- Billy Jean King Tennis Racket. Orig. \$12.95. **Sale 4.99**
- Billy Jean King, Jr. all-star Tennis Racket. Orig. \$9.95. **Sale 4.99**
- Slasinger Diplomat Tennis Racket. Orig. \$20. **Sale 6.99**
- Slasinger Personal Wood Tennis Racket. Orig. \$28. **Sale 10.99**
- Slasinger Final Aluminum Racketball Racquet. Orig. \$20. **Sale 7.99**

**Only 48 units to sell.**  
**J. C. Penney Westland Only**

**Bowling Shoes 50% Off**

Orig. \$19.99 to \$25. Selected men's and women's looks in mostly lace-to-toe vinyl bowling shoes with padded insole. Most sizes. Only 100 pair to sell.

**J. C. Penney Westland Only**

**General purpose battery Sale.**

- D-size battery twin-pak. Orig. \$2.29. **Sale 99¢**
- "AA" size battery twin-pak. Orig. \$1.39. **Sale 69¢**
- 9 Volt heavy duty battery. Orig. \$1.49. **Sale 69¢**
- Alkaline C size battery twin-pak. Orig. \$1.99. **Sale 99¢**

A total of 960 units to sell.  
**J. C. Penney Westland Only**

**Vinyl Luggage Closeout! Sale 9.99 to 29.99**



Orig. \$15 to \$43. Fashionable Softside luggage in assorted pullman and totes. Comes in blue or brown with grained vinyl. Lots of features, only 30 to sell. Save 30%.

**J. C. Penney Westland Only**

**25% Off**  
In Store Only

**Selected stone rings, wedding bands.**

**Sale \$48 to \$225**

Orig. \$65 to \$300. A limited selection, but the values are super. The group includes men's and women's looks in 10 and 14K gold. Some matched sets.

Only 50 to sell.  
**J. C. Penney Westland Only.**

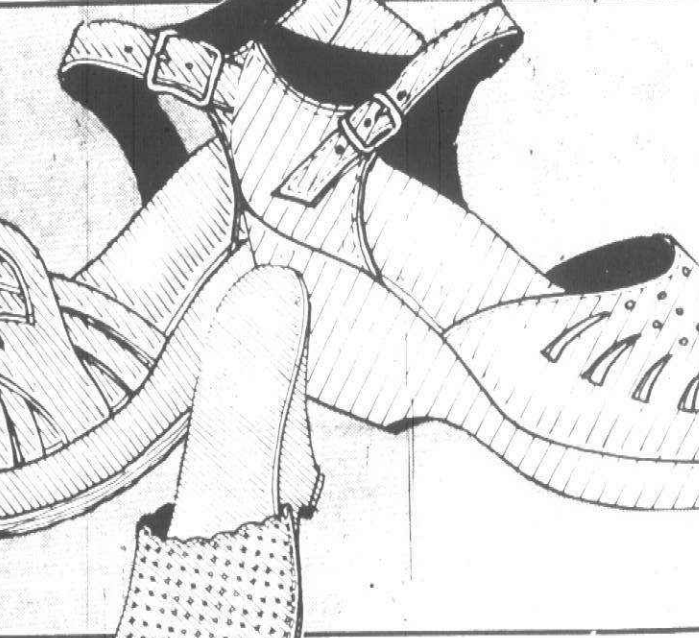
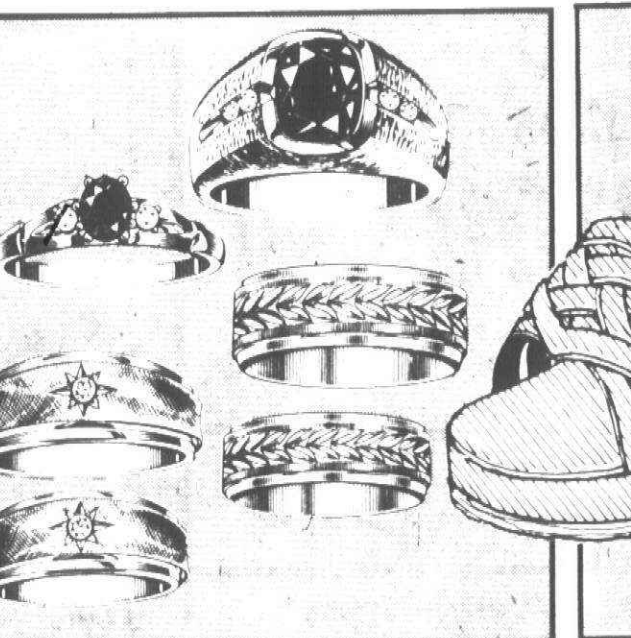

**Ladies Shoes Sale 2.99 to 3.99**

Orig. \$3.99 to \$8.99. A great selection of women's summer sandals, mostly vinyls in the group. Some heels and slides too. Most sizes. Only 450 pair to sell.

**J. C. Penney Westland Only**

**Girls Shoes Sale 3.99**

Orig. \$7.99 to \$10.99. Selected Summer sandals and slides. Mostly vinyls, pastel shades, most sizes. 150 pair only.

**J. C. Penney Westland Only**

**50% Off**

**Boxed Christmas cards.**

Orig. \$2.50 to \$7. Christmas cards from famous makers. Great choice of traditional, religious and whimsical themes. Now's the time to save. Only 300 total units.

**J. C. Penney Westland Only**

**Famous-make Jewelry Boxes Sale 75% Off**

Orig. \$15 to \$25. Sale \$3.75 to \$6.25. Buy for holiday giving now and save big. A beautiful way to protect her treasures. Selected styles only.

Only 40 to sell.  
**J. C. Penney Westland Only**

**Ladies Clutch Handbags NOW 5.99**

Special savings. We have a select group of vinyl clutch bags in dark colors only. Only 100 to sell.

**J. C. Penney Westland Only**

**Ladies Suede Gloves Sale 5.99**

Orig. \$10

Suede gloves with acrylic knit lining. Buy now for fall. Dark colors. The savings are big. Only 200 pair to sell.

**J. C. Penney Westland Only**

**Address Books Now 25¢ to 50¢**

Great organizers at a Penney-wise price. 3 1/2 x 6" pocket size. Only 250 units.

**J. C. Penney Westland Only.**

**Carded Buttons Orig. 75¢ to \$1.50 Sale 14¢ card**

Stock up now for your fall sewing. Choose from 4 to 6 per card, assorted sizes and colors. Only 200 cards to sell.

**J. C. Penney Westland Only**

**Fashion Dress Sale 9.99**

Orig. \$18 to \$32. You'll love our easy-to-care for cool and crisp styles. And the savings. Sizes for Misses and Juniors. Hurry while they last. Only 100 to sell.

**J. C. Penney Westland Only**

**Ladies Tunic Tops Only 7.99**

Special savings on these polyester tunic tops in the best prints around. Sizes 10-18. Only 100 to sell.

**J. C. Penney Westland Only**



**Famous name watches. NOW 29.88**

In-Store Only

Famous brand 17-jewel sport and dress watches for men and women. Day, date and calendar watches and many other with special features. Only 40 to sell.

**J. C. Penney Westland Only**

**Men's Ties reduced Sale 3.99**

Orig. \$5 to \$6. Selected Summer looks in solids, prints and plaids. Most are crease-resistant woven polyester in good colors. Only 200 to sell.

**J. C. Penney Westland Only**

**Ladies Sunglasses Sale 1.99**

Orig. \$4 to \$6. Choose from selected classic and contemporary looks.

Only 100 pair to sell.  
**J. C. Penney Westland Only**

**Juniors T-Shirts Only 2.99**

Keep your cool this summer in our poly/cotton tee. Darks and lights for Juniors, and priced for the smallest budget. Only 100 to sell.

**J. C. Penney Westland Only**

**Latch Hook Kits Sale 4.99**

Reg. \$8. Assorted Muppet subjects in assorted sizes. Complete with yarn and instruction booklet. Only 60 to sell.

**J. C. Penney Westland Only**

**Stoneware Mugs Sale 1.29**

Orig. \$1.99 each. Assorted mugs by Stoneware. Great for gifts or for yourself. Only 360 units to sell.

**J. C. Penney Westland Only**

**Ladies Knee-highs 99¢**

Special savings on ladies cable pattern knee-highs, soft textured, smooth fitting acrylic, fall colors. S, M, L. Only 300 pair to sell.

**J. C. Penney Westland Only**

**50% Off** Selected in-stock dehumidifiers.  
**J. C. Penney Westland Only**

**J C Penney**

**50% Off** Electrical Hardware  
Orig. 99¢ to \$5.99. Choose from electrical boxes, assorted electrical fittings, switch plates, door bells, chimes and others. Only 350 units.  
**J. C. Penney Westland Only**

# 51 years separated youngest from oldest delegates

## Favors moderation

By TOM LONERGAN



Saul Anuzis got a taste of big-time politics in his own backyard. (Photo by Dick Kelley)

It didn't bother Saul Anuzis — at 21 the youngest Michigan delegate — that his first Republican National Convention was held in his own backyard.

"It's probably the only way I could make it," said the University of Michigan-Dearborn student government president. "I probably couldn't afford it any other way."

A westside Detroit, Anuzis opted for his own bed at home rather than joining his fellow delegates in headquarters at the Holiday Inn, Metro Airport.

He still had to trek out to the Hilton Inn at Metro Airport where the 82-member Michigan delegation held its caucuses.

ANUZIS, A senior economics major at UM-D, estimated that most delegates spent anywhere from \$100 to \$150 a day during the convention, which ends this evening.

His budget didn't allow for that. Anuzis said he wasn't planning to go to "a single event that I have to pay for, which probably limits me to three."

Many cocktail parties held between and after convention sessions doubled as fundraisers. Minimum entry prices were \$25 and \$35, he said.

Anuzis, Michigan youth chairman for the George Bush campaign, was one of 15 at-large delegates chosen by the state Republican convention last month.

His "contemporaries" included Gov. William Milliken, former Gov. George Romney, state party chairman Mel Larsen and U.S. Rep. Carl Pursell, R-Plymouth, pledged until Wednesday's nomination vote to George Bush.

On the Reagan side, Anuzis' fellow at-large delegates included multi-millionaire financier Max Fisher, former

little to the right," Anuzis said, but he added:

"I agree with a lot of the things they (the mostly conservative GOP platform writers) say."

Anuzis supports Reagan moving towards the moderates to prevent "making the mistake that Goldwater did."

"The country has not yet gone that conservative," he added. "We need moderation a little."

## Stresses involvement

By ARLENE FUNKE

Senior citizens should "get off their duffs and out of their rocking chairs and get involved."

Those are the words of Marie Wentela of Dearborn, who, at 72, is the oldest Michigan delegate to the Republican National Convention.

Miss Wentela, a retired executive secretary, also believes young people would understand the problems of the elderly if they had more contact with them.

In stumping for senior citizen rights, she serves as the Michigan Republican Party's vice chairwoman for senior citizen issues. She has testified before congress and served on state and local task forces.

"THERE ARE three million senior citizens in Michigan," she said. "We have gone through a terrific youth complex. You cannot blame the young. It's a two-way street."

She admits to feeling "bugged" when people try to treat aging as a separate entity, rather than as a part of life.

Miss Wentela also comments on local and national trends. "We went to Washington to fight for funds to keep elderly persons at home," she said. "In 1979, it cost \$13.75 a day to maintain a person in a day care center versus \$27-plus on Medicare in a nursing home."

LOCALLY, SHE praises a program in the Wayne-West-



Marie Wentela is active in fighting for issues that affect older citizens. (Photo by Stephen Cantrell)

land School District that uses senior citizens to teach or lecture to youth.

However, she criticized Detroit's splitting away from the Area Agency on Aging to form its own agency. Miss Wentela said the break "adds to the bureaucracy."

The agency on aging gives out federal money for senior citizen programs. As a result of the split, several out-Wayne County communities got together to form a new consortium. That consortium begins operation Oct. 1.

She also said she was unhappy about the national platform stand on the equal rights (for women) amendment.

"I'm very unhappy, and am sorry I was unable to march (Monday in support of the ERA)."

### STEINWAY PIANOS

"Built to a Standard, Not to a Price"



There are few secrets left today in the art of piano manufacturing. The materials used and the skills employed are known to all. Why, then, does the STEINWAY PIANO stand alone in the eyes of the music world as the standard of how a piano should sound and perform? LISTEN to the answer at HAMMELL MUSIC where you can select from Michigan's Largest display of Grand Pianos.

Southeastern Michigan's Exclusive Steinway Franchised Dealer.

## HAMMELL MUSIC, INC.

"Since 1948"

15630 Middlebelt (North of Five Mile) Livonia 427-0040

### CARPET CLEANING

'Deep Steam'

ANY 2 ROOMS **\$39.95**

SAVE \$10.00

Additional Room \$15.00 NO SIZE LIMIT

Includes:

- Color Brighteners
- Spotting
- Soil Guard
- Deodorizer
- Furniture Pads
- Traffic paper

**SAME DAY SERVICE**  
Have your carpet cleaned today!  
CALL NOW FOR APPOINTMENT

With this ad Offer Expires 7-22-80

### FOUR SEASONS CARPET SALES SERVICE

2871 PLYMOUTH RD., REDFORD Charge ill **937-3800**

### mattness Warehouse

OPEN TO THE PUBLIC  
3 DAYS ONLY



FIRM		FIRMER		FIRMEST	
TWIN SIZE EACH PIECE	\$39	TWIN SIZE EACH PIECE	\$54	TWIN SIZE EACH PIECE	\$69
FULL SIZE EACH PIECE	\$49	FULL SIZE EACH PIECE	\$74	FULL SIZE EACH PIECE	\$89
QUEEN SIZE SET	\$139	QUEEN SIZE SET	\$209	QUEEN SIZE SET	\$239
KING SIZE SET	\$179	KING SIZE SET	\$249	KING SIZE SET	\$289

**LIVONIA**  
28691 PLYMOUTH ROAD (BET. MIDDLEBELT & INKSTER)  
261-8180

**BERKLEY**  
3165 12 MILE ROAD (BET. COLLIDGE & GREENFIELD)  
547-7770

HOURS:  
MON., THURS. & FRI. TIL 9  
OPEN DAILY & SAT. TIL 5:30

### 8 ft. x 6 ft. x 3/4" STOCKADE FENCE

**\$16.99** Posts section 4x4x8' Cedar - \$4.35

## RANDOLPH FENCE & SUPPLY

29820 W. 9 Mile — W. of Middlebelt Farmington Hills 476-7038

## GOP Week at Saks Fifth Avenue

In our Troy store...

July 16 and 17  
Frances Henaghan...Bright, comfortable fabrics and easy flowing lines for fall. Sportswear Coats, Suits and Dresses, First Level.

July 16, 17 and 18  
Cuy Lento, Lancôme's Skin Care and Makeup expert will be on hand to meet with you and plan a personalized skin care program and makeup look that is yours alone! Cosmetic Collections, First Level.

July 17  
Giacca...Handknit textured sweaters, in short and long styles, with matching hats! Designer Sportswear, First Level.

Richard van Vrooman...Vice President of La Prairie will be appearing today from 11 am to 3 pm. Cosmetic Collections, First Level.

July 17 and 18  
Jennifer Hackett personally presents her beautiful hand-painted silk scarves, ties and accessories. Accessories, First Level.

Carol Larson...In our Troy store with her unique designs in rare and semi-precious stones. Fashion Jewelry, First Level.

July 17 and 18  
Hanae Mori Collection...Regency Salon, Third Level.

July 19  
Ernst Strauss...Sophisticated charm with a European flavor. Regency Salon, Third Level.

In our Fairlane store...

Thursday, July 17  
Star Spangled Evening Looks...mini-show today at 12:30 pm, in Fifth Avenue Collections, Upper Level.

Thursday and Friday, July 17 and 18  
Ernst Strauss Collection...today and tomorrow in the Regency Salon, Upper Level.

Charles Coppinger...from Chanel Beauty will be appearing today and tomorrow from 10 am to 5 pm. In Cosmetic Collections, Lower Level.

Friday, July 18  
SFA/USA...The Best of the Best from America's Top Designers! Informal modeling from 12 noon to 3 pm.

## Saks Fifth Avenue

Somerset Mall, Big Beaver at Coolidge, Troy • Fairlane Town Center, Dearborn

### KLEIN'S NEWBURGH PLAZA

THREE DAYS ONLY THURSDAY • FRIDAY • SATURDAY JULY 17, 18, 19

## SIDEWALK SALE

All Summer Merchandise

# 20%-50% OFF

ORIGINAL TICKET PRICE

FOR WOMEN	FOR MEN
SHORTS	SWIMWEAR
TANK TOPS	SHORTS
SLACKS	SLACKS
SKIRTS	SPORT SHIRTS
GOLF SKIRTS	DRESS SHIRTS
BLOUSES	TANK TOPS
T-SHIRTS	T-SHIRTS
BLAZERS	JACKETS
DRESSES	BLAZERS
COATS	VESTS
SHOES	CO-ORDINATES
SLEEPWEAR AND MORE!	SHOES AND MORE!

There's so much on sale, we can't fit it outside!

## KLEIN'S NEWBURGH PLAZA • LIVONIA

37101 W. SIX MILE AT NEWBURGH RD. MON.-FRI. 10-9:00 • SAT. 10-6:00 464-7660 SORRY, NO LAYAWAYS ON SALE ITEMS

### Westland GARDEN CENTER AND NURSERY

SEE OUR LARGE SELECTION OF UNUSUAL SPECIMAN PLANTS

**EVERGREENS**  
White Pine, Blue Spruce, Douglas Fir, Alberta Spruce, and many more varieties

**READY TO PLANT POTTED SHADE TREES**  
Crimson King Maple, Rubrum Maple, Norway Maple, Moraine Locust, Green Spire Linden and Mountain Ash.

COMPLETE LANDSCAPE & DESIGN SERVICE INCLUDING DECKS & PATIOS  
**32593 CHERRY HILL WESTLAND • 721-6610 (BETWEEN MERRIMAN & VENOV)**

Mon.-Fri. 9-6 Sat.-Sun. 9-4

### YES-SECURITIES THAT EARN 14.5% INTEREST

TAX DEFERRED\* SECURED & INSURED \$10,000 MINIMUM NOT REQUIRED

BUT-RATES ARE DROPPING...  
In Livonia area **CALL NOW (313) 425-9000**

\*May be tax deferred within the structure of your Keogh Pension Plan or individual Retirement Account, either new or existing. ATTENTION RECENT RETIREES with lump sum pension money; roll over into an Individual Retirement Account to further defer taxes.

GRAND RAPIDS: (616) 942-1980 FLINT: (313) 733-6780 MIDLAND: (517) 636-7020

## REMVEST SECURITIES INC.

Remvest Building 33636 Five Mile Rd. Livonia, MI 48154

Yes, I'm interested in increasing my investment potential.

NAME \_\_\_\_\_  
ADDRESS \_\_\_\_\_  
CITY \_\_\_\_\_ STATE \_\_\_\_\_ ZIP \_\_\_\_\_  
PHONE (AREA) ( ) \_\_\_\_\_

The securities are offered by offering circular only. Available at company office, which explains "secured" and "insured" and are for sale only to bona fide residents of the State of Michigan and are not intended for resale to nonresidents.

**MONTGOMERY WARD**

Now thru Saturday

# The Sale of Sales

Items on this page (except steam/dry iron) are not at Allen Park



**Save 1/2**  
Men's luxurious shirt of silky no-iron polyester  
**4<sup>97</sup>**

Regularly \$10

Get the feel of smooth, rich silk in these short sleeved dress shirts of machine washable woven polyester. Choose from cool colors and white; with pocket and comfortably tailored collars. Sizes 14 1/2 to 17. Stock up now at 50% off!



**Save 43%**  
Our best-selling Misses, juniors' designer jeans  
**8<sup>97</sup>**

Regularly \$16

You'll love the slim, trim fit and the designer touches that we put into these machine washable all-cotton jeans. Novelty pocket stitching, slim leg tailoring and more. Junior sizes, 5 to 13; misses sizes, 8 to 18. Get them now and save!



**Special**  
Men's classic vested suits  
**49<sup>97</sup>**  
Save at Wards  
Solid-tone suits in polyester knit. Flap-pocket jacket, 5-button vest and belt-loop pants. Regs., tall.  
All summer suits now 1/3 to 1/2 off

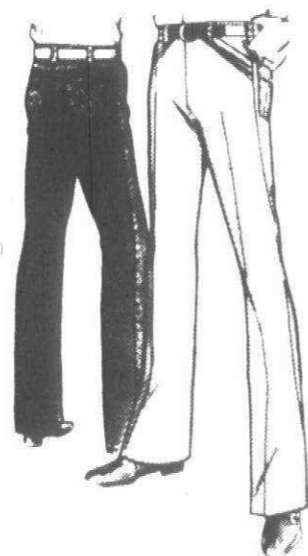

**Save \$7**  
Men's fashion jeans, real style winners.  
**9<sup>97</sup>**  
Regularly \$17  
New looks, details he wants in cotton or cotton/polyester. Machine wash 29-38.  
All other fashion jeans now 1/3 off



**Save 37%**  
"Magic Cross" bra: soft cup or contour.  
**2 for \$5**  
Reg. 3.99 each  
Nylon polyester cotton; nylon Lycra™ spandex elastic. Soft cup: B, C Contour with polyester fill: A, B, C  
4.50 stretch bra ..... 2 for \$6  
3.99 plunge bra ..... 2 for \$5

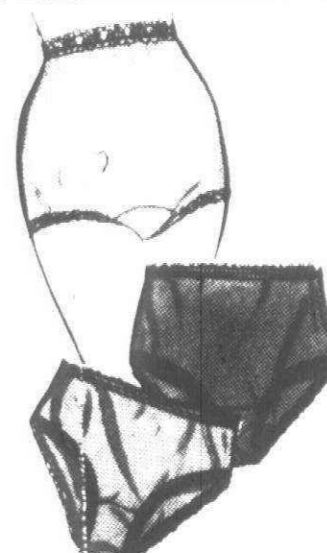

**50-58% off**  
Misses' soft and absorbent panties.  
**74¢**  
Reg. 1.49 to 1.79

Briefs, in cotton, double-fabric crotch. 5-8 Bikinis, hipuggers or ribbed knit, polyester cotton. Sizes 5-7

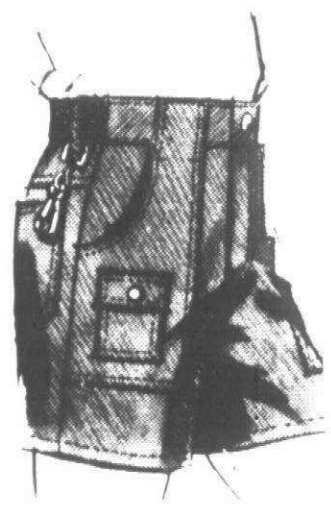

**50% off**  
Rugged twill camp shorts for boys.  
**3<sup>19</sup>**  
Regularly 6.49  
Polyester/cotton with elasticized back at waist, pockets galore, flashlight clip. Machine washable. 8-16.  
Boys' Department  
Other boys shorts ..... 1/3 off



**Save 50%**  
Boys' terry cloth sport shirt buy  
**5<sup>97</sup>**  
Regularly 11.99  
Machine washable in a variety of solid colors and combinations. Collared and collarless. Sizes 8 to 16.  
Other short sleeve terry shirts ..... 1/3 off

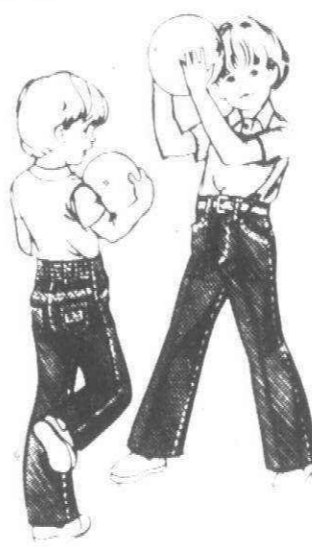

**Save \$2**  
'Power Denim' jeans for little boys.  
**5<sup>99</sup>**  
Regularly 7.99  
Our toughest in no-iron polyester/cotton nylon. Bar-tacked at stress points; double knees. 3-7 slim, regular.



**Save \$2**  
Park Bench Kids' boxed jogger sets.  
**3<sup>97</sup>**  
3-pc. set  
Regularly 5.99  
Adorable shirt, matching shorts in no-iron cotton/polyester; socks in cotton-nylon. New born size. Great gift.



**Save \$11**  
Men's leather work oxfords  
**19<sup>97</sup>**  
Regularly \$31  
Glove leather with Goodyear Welt, oil-resistant sole. D8-11.  
\$34. 6-in. shoe ..... 21.97  
\$36. 8-in. boot ..... 23.97  
Other work boots ..... 1/3 off

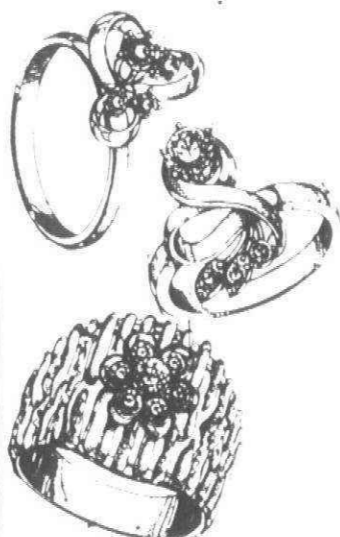

All our LeGant® diamond jewelry in gold settings  
**30% off**  
Fiery diamond rings, earrings and pendants in elegant white or yellow 14k gold settings. Fine quality.



Classic 14k gold serpentine style fashion chains  
**1/2 off**  
Lustrous luxury in gleaming chains that will accent any costume. Get them now!

7-in. reg. \$28 ..... 13.88  
15-in. reg. \$49 ..... 23.88  
18-in. reg. \$57 ..... 27.88  
24-in. reg. \$80 ..... 39.88



**Save 1/2**  
Sunglasses with SunSensor™ lenses.  
**\$5**  
Regularly \$10  
Corning lenses get darker as light gets brighter. Assorted men's, ladies styles.



**Save 34%**  
Big Mama pantyhose has reusable panty.  
**2/3<sup>3</sup>**  
Reg. 2.29  
Nude heel, reinforced toe, cotton crotch. Nylon XXI.



**Save 1/2**  
Fashion handbags in canvas and corduroy  
**4<sup>50</sup>**  
Reg. \$9  
Top handle or clutch in smooth cotton canvas or ribbed corduroy.

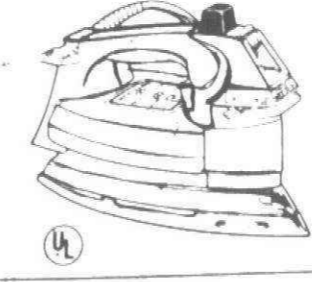

**Save \$5**  
Steam/dry iron with spray-mist action.  
**14<sup>97</sup>**  
Reg. 19.99  
10-oz. see-thru plastic tank  
29 vents, reversible cord  
18.99 ironing table ..... 11.97

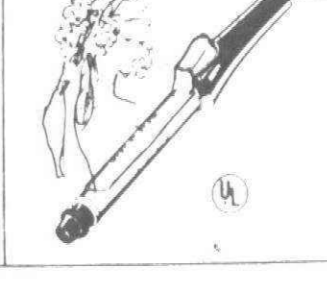

**Save \$10**  
Compact mist curling iron travels anywhere.  
**4<sup>88</sup>**  
Reg. 14.99  
10" long, take it everywhere  
Swivel cord and built-in stand.

LOOKING FOR A WAY TO SIMPLIFY YOUR MONTHLY BUDGETING? MAYBE A WARDS CHARG-ALL ACCOUNT IS THE ANSWER

ANN ARBOR Arborland Center 971-2750	ALLEN PARK 16670 Southfield Road 386-9440	DEARBORN Michigan St. Schaefer 584-0500	DETROIT Grand River at Greenfield 835-4200	DETROIT Gratiot nr 7 Mile Road 371-1100	MT. CLEMENS 15 Mile Road at Gratiot 791-2000	PONTIAC Telegraph at Elizabeth Lk Rd 682-4940	SOUTHGATE Trenton at Eureka Road 285-4400	SOUTHFIELD Telegraph at 12 Mile Road 358-1200	STERLING HGTS. Hall Road at Schoenherr 254-3900	WARREN Dequindre at 12 Mile Rd. 751-7500	WONDERLAND Plymouth at Middlebelt Rd 427-1600
---	---	---	--	---	--	---	---	---	---	--	---

**MONTGOMERY WARD**

STORE HOURS: Monday thru Saturday 10 a.m. to 9 p.m.—Sunday 12 noon to 5 p.m.  
 Grand River: Monday thru Friday 10 a.m. to 8 p.m.—Saturday 10 a.m. to 6 p.m.—Sunday 12 noon to 5 p.m.  
 Gratiot: Monday thru Saturday 10 a.m. to 8 p.m.—Sunday 12 noon to 5 p.m.  
 Allen Park & Dearborn: Daily 10 a.m. to 9 p.m.—Saturday 10 a.m. to 6 p.m.—Sunday 12 noon to 5 p.m.  
 Pontiac & Ann Arbor: Daily 10 a.m. to 9 p.m.—Saturday 9:30 a.m. to 9 p.m.—Sunday 12 noon to 5 p.m.  
 Toledo South: Monday thru Saturday 10 a.m. to 9:30 p.m.—Sunday 12 noon to 5:30 p.m.  
 Toledo North: Monday thru Saturday 10 a.m. to 9 p.m.—Sunday 12 noon to 5 p.m.  
 Sandusky: Monday thru Saturday 10 a.m. to 9 p.m.—Sunday 12:30 p.m. to 5:30 p.m.

# ...Don't miss it!



Save 1/2

Twin or full Airglide mattress or foundation

Super-firm, quality bedding with heavy-gauge steel coils and edge supports to prevent sagging. Durable woven, quilted floral print covering. Matching torsion-bar foundation. Save!  
 Queen size 2-pc. set, regularly \$399.99 \$269  
 King size 3-pc. set, regularly \$519.99 \$349

**\$69 \$84**

Twin size, ea. pc. Regularly \$139.99 Full size, ea. pc. Regularly \$169.99

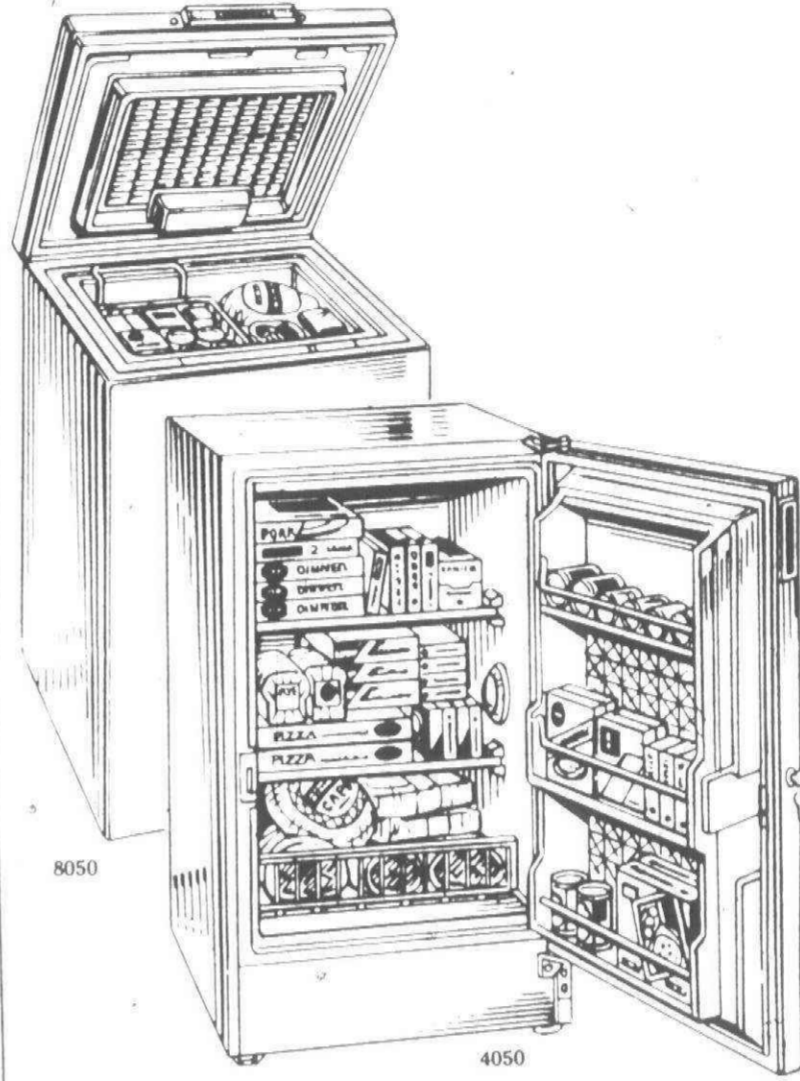

Save \$30  
 Our space-saving  
 5.1-cu.ft. chest  
 or upright freezer

**219<sup>88</sup>**

Regularly 249.99

Both feature textured steel door/lid security lock/key and adjustable cold control. Upright model has two shelves and magnetic basket plus additional storage in door. Chest model with interior light and removable basket. Your choice, 219.88.

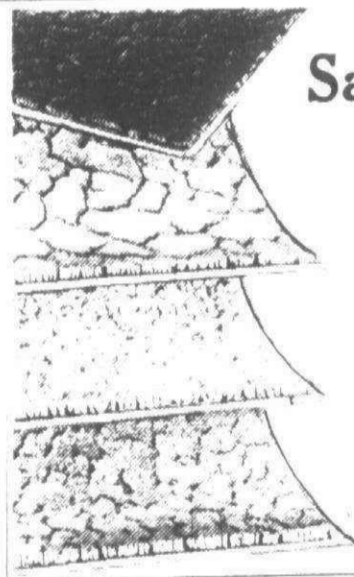

Save 13-40%  
 Large room-size  
 rug remnants

**14<sup>97</sup>**  
 4x6-ft.  
 Regularly 24.99

Wide choice of sizes, colors, styles. All edges finished. Save now!  
 49.99, 6x9-ft. \$39.97  
 109.99, 9x12-ft. \$89.97  
 139.99, 12x12-ft. \$119.97  
 179.99, 12x15-ft. \$149.97  
 219.99, 12x18-ft. \$189.97



Save \$30  
 Easy-care vinyl  
 2-way recliner

**99<sup>97</sup>**

Regularly 129.99

High button-tufted back, smooth roll-arm, wide seat. Hardwood frame construction. Save now!

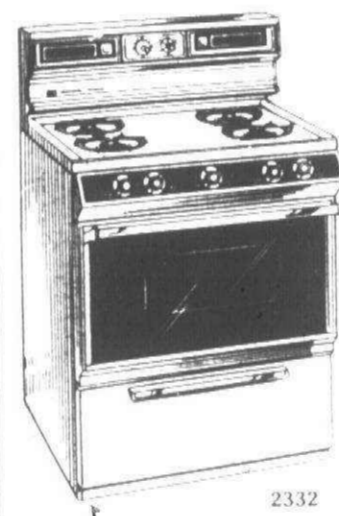

Save \$100  
 Pilotless 30-inch  
 gas or elec. range

**299<sup>88</sup>**

Regularly 399.99

No pilot for oven or burners. Removable glass oven door, lift up cooktop, clock and timer, more. Save!

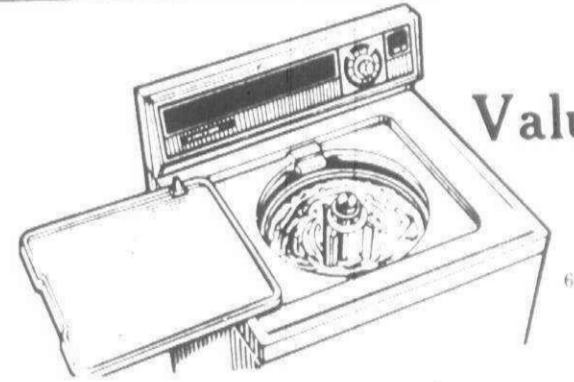

Value

4-cycle, plus-capacity auto. washer  
 Handles large washloads.  
 Pressure-fill water-level system, 3 temp. combos.  
 Heavy-duty transmission.

**\$249**

Save at Wards



Save \$35  
 TR discriminator  
 treasure finder.

**99<sup>97</sup>**

Regularly 134.99

With adjustable discriminator mode to eliminate signals from foil, cans. Tuning and volume controls.  
 Batteries included.

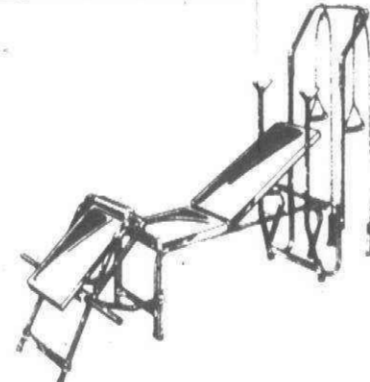

Save \$50

Versatile fitness combo keeps you trim  
 Tubular steel frame, 600-pound capacity. Arm curl, leg lift, wt pulley attmts.

**69<sup>97</sup>**

Regularly 119.99

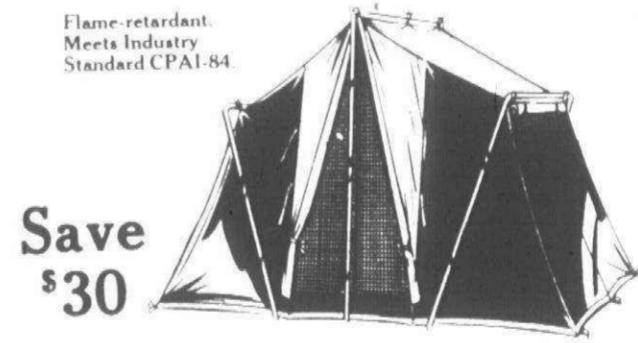

Save \$30

Sturdy 8x10-ft. canvas cabin tent  
 Polyester/cotton canvas with screened windows and door, light yet sturdy aluminum frame. Save!

**99<sup>88</sup>**

Regularly 129.99

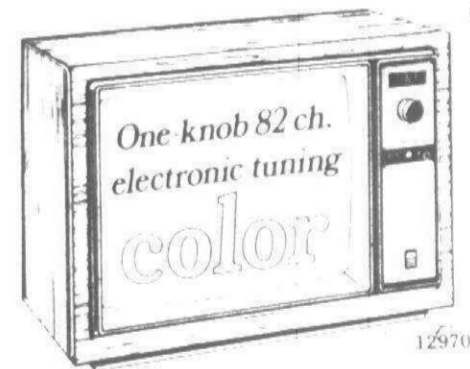

Simulated wood

One knob 82 ch. electronic tuning  
 color

Save \$60

19" diag TV features electronic tuning. Single knob tunes in all 82 channels. Auto Color System, neg-matrix tube.

**369<sup>88</sup>**

Regularly 429.99

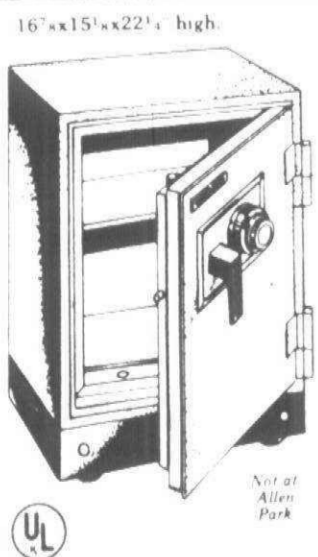

Save \$40  
 Floor safe guards  
 valuables 3 ways.

**129<sup>97</sup>**

Five locking bolts, re-locking device, 2 1/2"-thick door. Passed rigorous fire and impact tests. 1.0 cu. ft.

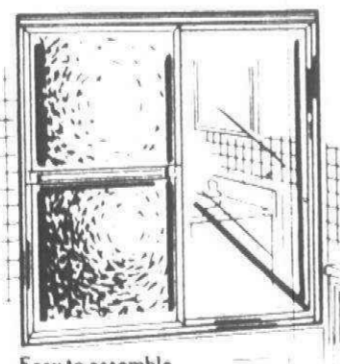

Save \$36

Our aluminum mirrored tub enclosure.  
 Gold- or silver-look aluminum trim. 1 mirrored panel. 60"x56" high.

**\$88**

Regularly 124.95

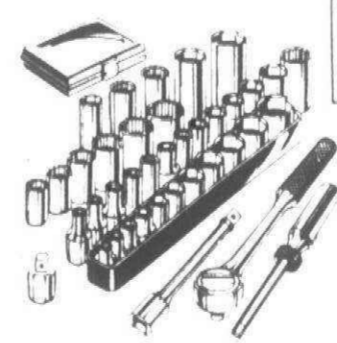

FULL NO-TIME LIMIT WARRANTY

Save \$54

Powr-Kraft SAE/metric socket set.  
 40-pc. 1/4", 3/8"-dr set includes ratchet, spinner handle, extension, case.

**29<sup>97</sup>**

84.91 separately

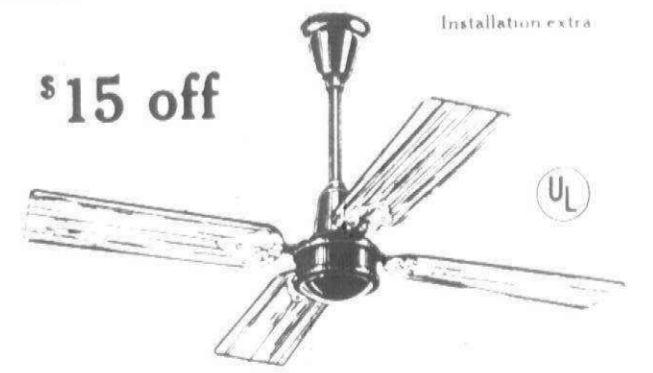

\$15 off

Ceiling fan has a 48"-diameter sweep.  
 4 walnut-stained wood veneer blades. Solid brass decorator plates. 5 speeds.

**69<sup>88</sup>**

Regularly 84.95

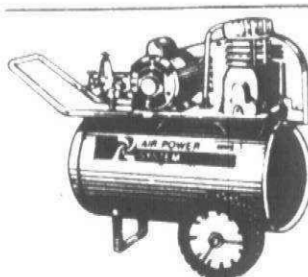

Special  
 1-hp air compressor  
 with 12-gallon tank.  
 Delivers 6.4 scfm at 40 psi. 100 psi maximum. Regulator incl.  
**\$249**  
 Save now!



Save 24%  
 Wards longest-lasting oil filter: X-tralife.  
 Protects your engine for up to 15,000 miles. Most US cars.  
**2/3**  
 Reg. 1.99 ea.



Save 19%  
 Mobil Super 10W40 motor oil, quart.  
 Cuts down engine wear; provides hot/cold weather starts.  
**88<sup>c</sup>**  
 Reg. 1.09

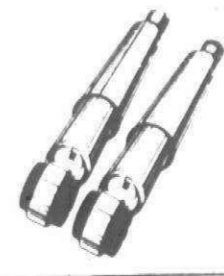

Save 30%  
 Heavy-duty 1 3/16-inch shock absorbers, ea.  
 All temp fluid, case-hardened rod for smooth riding. Save!  
**6<sup>97</sup>**  
 Reg. 9.99

Now charge it three ways . . .



# Officials have to act—even in election year

It's political shenanigan time again. The Township Board is playing a stalling game with the citizens of Canton Township in an effort to alienate no one before the primary election. The board's tactics became painfully clear recently when several residents stormed a board meeting with complaints about a proposed fence regulation. The Township Board has addressed more earth-shattering issues than fences in the past. But few matters incite property owners more than a government edict on what they can and cannot do with their land. Board members expected fury from hundreds of residents no matter which way they decided to act. So in their political wisdom, members decided to take no action at all. The issue extends far beyond fences. The issue

involves politicians and their unwillingness to risk disfavor in an election year. THE BOARD'S inaction at its last regular meeting July 8 would make a good script for a political comedy—or tragedy. Only two weeks earlier, the board informally agreed to ban fences in the sideyards of some corner lots. Ordinance director Bruce Phillips, who is rewriting the fence ordinance, said numerous homeowners have complained vehemently about the current law. Current regulations require some corner-lot owners to seek permission from their next-door neighbor before erecting fences along their side lot lines. The restriction applies only to corner lots with side and backyards abutting front yards of an adjacent house. In those cases, the two houses face adjacent streets.

Neighbors of corner-lot owners say the current policy detracts from the aesthetics of their houses by planting fences in their front yards. They shun risky bad relations with their neighbors by saying no. The board had those residents in mind when it informally agreed in June to ban side yard fences.

BUT ON JULY 8, corner lot owners stormed into the meeting hall. They cited the right to fences as an inalienable property right.

The board hemmed and hawed in a 1½-hour discussion of the issue. With the exception of Treasurer Jim Donahue, who is not seeking re-election, and Trustee Carol Bodenmiller, who is, board members indicated that they may change their mind on the issue.

The result was a tabling resolution. The board directed Supervisor Noel Culbert to schedule a study session on the matter. Culbert later admitted no plans to "hold that thing before the election." Such attitudes underscore a basic fault with our democratic election process. But it's a fault which voters should not excuse or brush under the rug. Members of the Township Board were elected to do a job, whether or not a primary is scheduled for the month ahead. Trying to please everyone all the time never works. As politicians, members of the Township Board should know that. Inaction on a fence ordinance probably won't cost a life. But inaction on another controversial issue could.

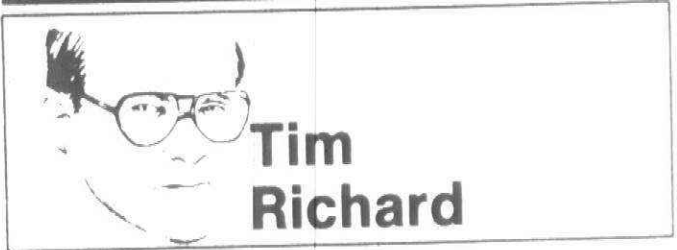

## One day's work, 3 days of showtime

One year ago almost to the week, I sat in a noisy pub in Brighton, England, with a lunchtime half-pint of stout. In English pubs, if there's an empty chair at a table, you just sit down, even if others at the table are total strangers. We shared the table with a man who I judged to be in his early 30s. From his clothes and conversation, he appeared to be an independent tradesman—plumber or repairman, perhaps. Far from being stuffy and reserved, the English are the most cordial, warm people in the world. In no time, we were chatting about the newspaper he was reading.

His opinion was that most British newspapers were junky—full of soccer, sports, scandal, crime, sex. His theory as to why this was so was interesting: Newspaper owners wanted to divert the general populace's attention from the serious issues of the day and simply keep them entertained. I couldn't agree with his analysis because there are many serious and well-written British newspapers—the London Telegraph, the Manchester Guardian, many local papers. Yet there was no denying his observation that the vast majority of people read newspapers that were mainly entertainment sheets.

I WAS REMINDED of our conversation this week as the Republican National Television Show hit the airways. I hesitate to call it a "convention." The major sessions are geared to prime TV time. TV reporters get big advantages in floor time over newspaper reporters. Serious floor debate has been eliminated, for all practical purposes, because it looks bad on TV.

Most incredible of all was the lineup of movie and TV stars who got on the air one evening. In terms of fostering understanding of national issues and alternative solutions, Wayne Newton and Susan Anton couldn't have helped a single voter.

You may have heard there are 2,000 delegates and 8,000 media people at the convention. From this, you could draw the erroneous conclusion that there are four reporters for every delegate. Not so. I would estimate half or more of those media people are producers, camera men, electricians, go-fers, receptionists, switch-pullers and other technical types. There really aren't so many reporters.

AMERICA HAS a presidential election campaign that lasts 14 months. A major industrial state like Michigan is visited several times by every candidate. And yet it is not incredible that Ronald Reagan has only one address, known as The Speech? Is it not incredible that in 1976 Jimmy Carter had only one address, known as The Speech? Is it not puzzling that George Wallace had only one address, known as The Speech?

Like the English newspaper favored by the populace, American television is giving us vast amounts of entertainment, star personalities, appearances and hoop la, but relatively little solid information, given the millions that are spent on it. One thing is clear after this week's gaudy spectacle in southeast Michigan: It took four solid days to broadcast, but all the major activities required only a day and a half.

Reagan has had a majority of the GOP delegates for six weeks, right? The roll call of the states and his acceptance speech could have been handled in 90 minutes, right? He could have announced his choice of a running mate, had it ratified and introduced the No. 2 man in another 30 minutes, right? As I said, it's all a television show, and it's mainly entertainment.

## ERA ardor dampened by deadline

The ERA litmus test will come long before its 1982 deadline. And from the lackluster turnout at recent Detroit Equal Rights Amendment rallies, that should be anything but a surprise. The voting public's commitment to the long-standing proposal has been severely challenged by the National Republican Party's ERA platform betrayal. While this country's female population should be outraged by this action, it is questionable whether it will unite to defeat Ronald Reagan in November. Republicans are ecstatic about their election chances in November, not only for the White House but for attaining a majority in the U.S. House of Representatives. If their July optimism turns to a November reality, it would be the ERA death knell. For if the GOP can wrest a majority in the U.S. House, it can do so in a number of key state legislatures where the ERA fate rests. Political demonstrations have become something of a cliché and just as meaningless. Americans have become indifferent to thousands of marching militants, no matter the cause. THE CHICAGO rally proved that. Even though hundreds of thousands gathered to support the ERA, reinforced by a bevy of celebrities, that failed to win over three-fifths of the Illinois legislature.



A dismal rally was attempted at the Kern Block Sunday that clearly demonstrated a lack of commitment by ERA supporters. Touted as a major rally, it featured the governor's wife, Helen Milliken; Detroit City Councilwoman Erma Henderson; excommunicated Mormon Sonia Johnson; and Eleanora Anderson, daughter of independent presidential candidate John Anderson. But even those heavyweight public figures couldn't bring out what one would call a respectable crowd. It is doubtful whether most Republican delegates were even aware of it. For much of the day, persons from the news me-

dia stood around looking at one another waiting for something to happen. Nothing much did. THE ACTION was across the street at Detroit's Kennedy Square where a much larger demonstration was being put on for the captive nations. At times, the din of that rally could be heard over the ERA speakers. While the National Organization for Women (NOW) rally on Monday was larger, it got little attention and was just another demonstration during convention week. Stop ERA conservatives have learned a valuable lesson, one which ERA supporters would be wise to heed. The real work in winning a cause rests with grass roots efforts over the telephone, through the mail and from door to door. Conservatives have done just that, electing candidates who oppose ERA and defeating others who don't. ERA supporters have neglected that type of political action. IF THE ERA is to be part of the U.S. Constitution, supporters must regroup and be willing to tackle grass roots efforts. But ERA defeat is in the air. And like any dying political movement, it suffers from supporters who have given up the fight.

## Blame officials if the fights are brutal

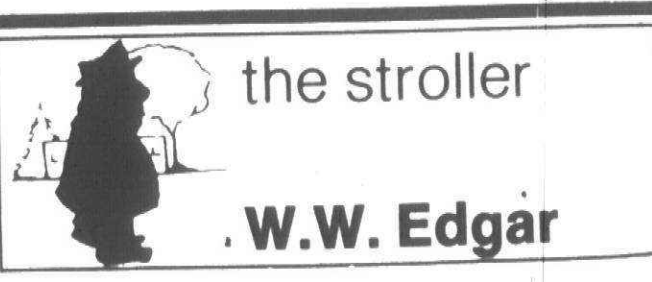

It long has been forgotten that what is now called the fight game started as the manly art of self defense. It was inaugurated as a means of showing the public how the humans could protect themselves with their hands. It never was meant to be brutal. Delving in to the records, you'll find that when James J. Corbett defeated the legendary John L. Sullivan for the heavyweight title, he was referred to as "Gentleman Jim." He gained the title by out-boxing Sullivan. Years later, Jack Johnson, who many claim was the best boxer ever to hold the heavyweight title, outpointed Jim Jeffries to gain the crown. NOT UNTIL Jack Dempsey came along WAS scientific boxing was cast aside, and he quickly earned the title of "The Manassa Mauler." Dempsey couldn't box, but he gained his victories by in-

In recent days, the public prints have been the sounding board for the hues and cries of the dogooders who abhor the so-called brutality in what they call the "fight game" and in many cases are asking for its banishment from the sporting scene. This is nothing new. Every now and then during the past century, the same hues and cries have been heard, and at one time they were heeded. In fact, the bouts were held on rafts in the lower Mississippi River as a means of getting around the ban. What these critics overlook is that the so-called brutality is the fault of the officials and the various athletic commissions who allow one-sided matches to continue when it is obvious that there is no question regarding the ultimate winner. A GOOD case in point happened just the other evening in Minneapolis when heavyweight champion Larry Holmes made a punching bag of his opponent and even asked the referee to stop the slaughter. His plea went unheeded for several rounds, and the critics had a field day calling attention to the brutality. After a round or two of this mismatch, it was evident Holmes' opponent should not have been in the same ring. And whoever sanctioned the match must never have seen either fighter in action. So the fault lies in the lap of the athletic commission that sanctioned the match and foisted it on the public.

flicting brutal beatings on his rivals. That is until Gene Tunney, a boxer, took the title from him. One reason for the so-called brutality in the prize ring today is the fact that the contestants haven't learned their trade. If you watch closely, not one is a body puncher. They all go for beating their rival with blows to the head. It is common knowledge that Joe Louis, during his climb to the heavyweight throne and his long reign, never was called upon to meet a body puncher. No one knows how he would have fared had he met one. Old Sam Langford, one of the greatest of the fighters who never gained the title, always preached, "Kill the body and the head will die." But few of the latter-day fighters have heeded his advice. From the opening bell these days, the fighter has only one goal—to knock the other fellow's head off. As a result, we have old timers going around now in a condition commonly known as "punch drunk." In most cases, they were allowed to continue taking a beating about the head when they no longer had a chance to win. So, the manly art of self defense should not be banned. But the blame for the present brutality is at the feet of the athletic commissions who condone mismatches and one-sided bouts.

# Do Detroiters love the party?

By JUDITH BERNE

They keep saying that Detroit loves a good party, but I wanted to know where the party began.

Sure, there are "Welcome GOP" signs in Birmingham's shopping district, delegation parties in Bloomfield Hills and hoardes of delegates staying at Southfield and Troy hotels, but I wanted to know if nuts and bolts Detroiters know or care if "Detroit loves a good party."

So I drove down Woodward toward "the foot of Detroit" earlier this week. Restaurants and shops along Woodward from Royal Oak to the Boulevard were generally devoid of any red, white and blue designation.

There was the usual traffic congestion in Ferndale, tennis courts appeared busy at Palmer Park and luncheon crowds were thick at the Boulevard.

The Detroit Institute of Arts from the outside looked like it was anything but ready for a party — it's in the midst of re-landscaping and expansion.

FINALLY, a white and blue drape hung from a pizzeria just south of the art institute and a short block later the modest "Homemakers Pantry" boasted a green and white hand-painted sign declaring "Welcome delegate" — singular, not plural.

Well, it always takes a while to get a party going.

The rows of boarded up stores until you hit downtown Detroit weren't welcoming anyone. And the area around Grand Circus Park was sparsely populated.

The, coming around the park to the Washington Boulevard trolley, a hint of the frivolity soon to hit along the riverfront began.

The yellow canopies at Kennedy Square had plenty of people beneath them as early afternoon temperatures approached 90.

A good-natured police woman directed traffic across Jefferson to the riverfront attractions — Renaissance Center, Hart Plaza, Ford Auditorium, Cobo and if you were lucky enough to beg, borrow, steal or come legitimately by the proper pass — Joe Louis Arena.

People dripping credentials were the rule. Most wore them on a chain around the neck.

I sneaked sidelong glances to see just who had limited access, full access or mere Secret Service clearance.

BUTTON, T-SHIRT and souvenir venders were out in full force. So were ice cream, flower and fruit sellers shouting their wares.

Organ music from the vintage Mariner's Church played out Anchors Away. The University of Michigan band reportedly had entertained lunch-time guests earlier in Hart Plaza.

Western hats, hats with elephant trunks and floppy ears and cameras — TV, movie and little Brownies — were everywhere.

The mood was airy and carefree. Balloons were all about. Yes, Detroit loves a good party — part of Detroit.

## ... These volunteers certainly do

By ARLENE FUNKE

Two hours before business sessions begin at Joe Louis arena, a small army of young men and women arrive for work.

There are about 240 of these folks who range in age from their mid-teens to college age. They come from all over the country, and their mission is to be at the beck and call of delegates on the convention floor.

Jeff Dixon of Canton Township and Lisa Dossette of Westland are typical of many pages in that their parents are party activists.

Lisa's dad, David, writes a newsletter for the 15th Congressional district. Jeff's father, Gary, also is active in the same district.

In addition, he is a member of a state Republican Party Committee.

"WE ESCORT people to the conference room," said Jeff, 16, who will be a junior next fall at Plymouth Salem High School.

"We get food and usually help set up the program," Jeff said it's "like another world, like a carnival. I just like being there and meeting other pages from Oklahoma,

'I stood in line for hours waiting to shake hands with Ronald Reagan and his wife Nancy. Mrs. Reagan is real pretty (and) he seems healthy.'

— Lisa Dossette, GOP 'goter'

Louisiana, Tennessee and California," he added.

An added attraction would be the parties, receptions and entertainment and waterfront activities behind the arena.

LISA, 18, AGREES that it's all pretty exciting.

"I stood in line for hours waiting to shake hands with Ronald Reagan and his wife Nancy," said the Wayne Memorial High School graduate.

"Mrs. Reagan is real pretty (and) he seems healthy."

So far, neither Jeff nor Lisa is inclined toward a political career. Lisa will be taking classes in dental technology, while Jeff is interested in a corporate law career.

"I think everybody should vote," added Lisa. "They should get involved. (People) aren't any help if they don't vote."

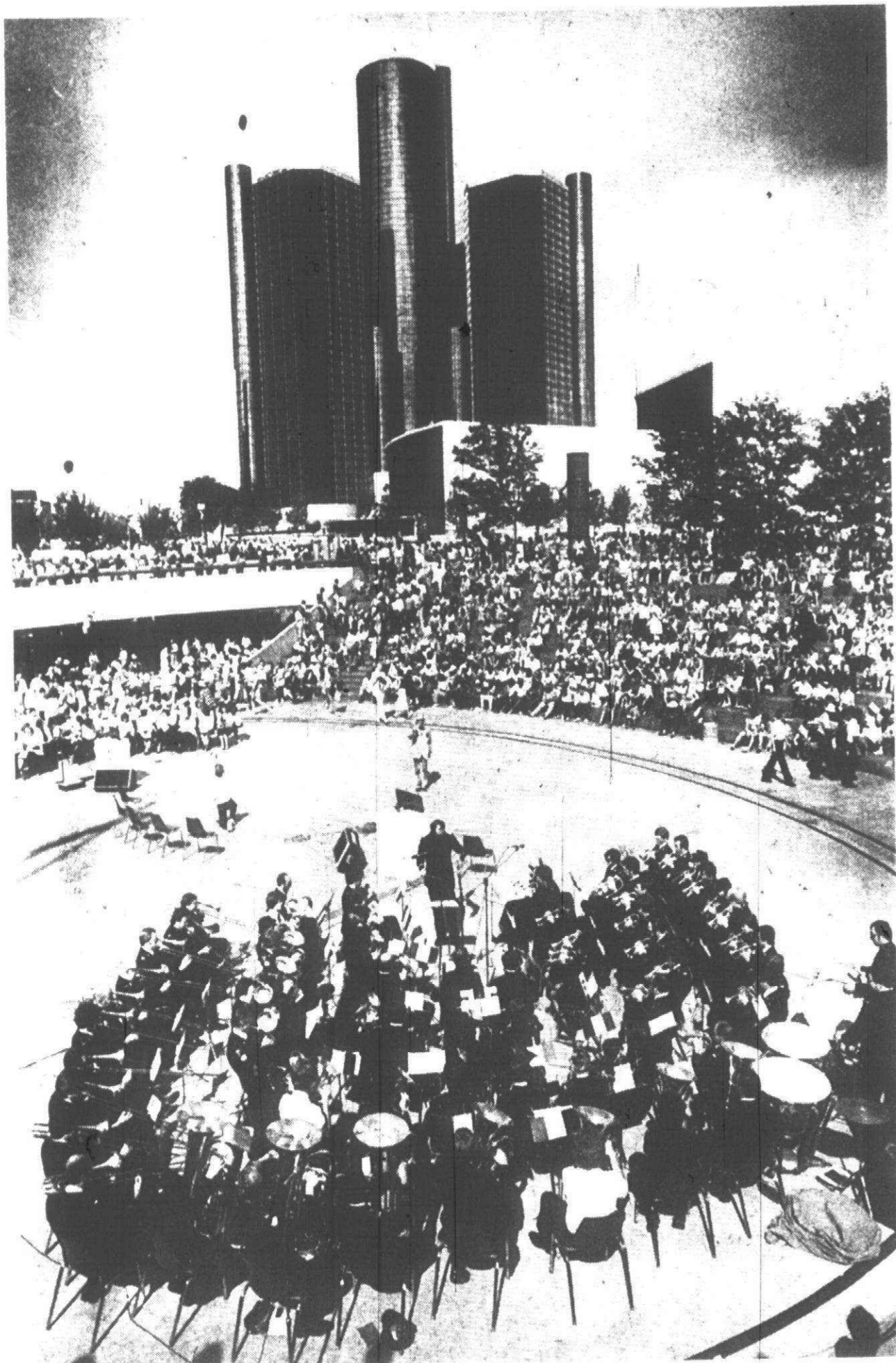

"Detroit loves a good party" such as this one furnished by the Salvation Army Band at Hart Plaza — or does it? The stories at right offer differing views. (Photo by Randy Borst)

**DECLARE YOURSELF A WCXI "COUNTRY LOVER."**

**JULY 25TH 1980**

On Friday, July 25th, WCXI Radio will award a luxurious AMC Eagle to a card carrying "Country Lover."

Become a card carrying "Country Lover". Mail one entry form (see below) to WCXI and keep your "Country Lover" card in your wallet (it's worth big discounts and free prizes).

I AM A WCXI "COUNTRY LOVER" AND PROUD OF IT!

**WCXI RADIO 11**

To win the AMC Eagle you must be 18, a licensed Michigan driver and a registered "Country Lover." Your entry must be received at WCXI Studios by 9 a.m. July 25th.

ONE AMC EAGLE WITH AUTOMATIC FOUR WHEEL DRIVE, AIR CONDITIONING, RADIAL TIRES, STEREO, TINTED GLASS, POWER STEERING AND BRAKES WILL BE AWARDED.

**WIN AN AMC EAGLE**

DECLARE YOURSELF A WCXI "COUNTRY LOVER"

Detach the "Country Lover Card" and keep it. Fill out the postcard, attach a stamp and mail to WCXI. Then list for your name on WCXI. You could win a WCXI shirt or both bus ticket or truck. Say, There will be concert tickets, LP's and more. For "Country Lovers" only on WCXI.

**"COUNTRY LOVER" CARDHOLDER RULES**

THIS IS NOT AN ENTRY FORM. PICK-UP OFFICIAL ENTRY FORMS AT ANY DETROIT-AREA AMERICAN MOTORS DEALER OR WCXI STUDIOS, 18900 JAMES COUZENS, DETROIT.

custom draperies

SAVE UP TO **33 1/3%** on Fabrics

- Styling with imagination
- Sensible prices
- Decorator fabrics
- Fine workmanship
- Direct mill buying

Labor Special \$5.50 per panel unlimited

**CUSTOM WOVEN WOODS** 40% OFF  
CONCORD, WESCO  
\*All previous orders excluded

**VERTICAL BLINDS** 50% OFF  
Decorator Cloths & P.V.C.  
\*All previous orders excluded

**HORIZONTAL 1" BLINDS** 40% OFF  
80 Decorator Colors  
"BALI" DESIGNER BLINDS  
\*All previous orders excluded

**Bath Shoppe** accessories UP TO 25% OFF  
towels, bath rugs, shower curtains

**Discount Bedspreads** 50% OFF  
Riverbreak, Puffin, Comforter, Eagle Mountain, Bouquet  
Orchard Lake store only

**DRAPERY BOUTIQUE COUPON**

**30% OFF ALL WALLPAPER**

Any book - Any group in our library. Freight and Handling Additional. Offer expires, Saturday, July 26, 1980.

No Charges Accepted Coupon must be presented upon placing order only

Customers own measurements Measuring & installation available, extra cost

**FARMINGTON TOWNE CENTER** 37041 Grand River Farmington (313) 478-3133 Daily 9:30-8:00 Mon. & Thurs. 9:30-8:30

**ORCHARD & 14 MILE CENTER** 30886 Orchard Lake Road Farmington Hills (313) 628-4313 Daily 9:30-8:00 Thurs. 9:30-8:00

**drapery boutique**

**Buyers Market Summer Sale:**

The best of Selig, all ours. All yours for 1/2 off.

Two piece sectional. Reg. \$1825 Sale \$899

Contemporary tub chair. Reg. \$600 Sale \$299.

Slouch couch. Reg. \$1400 Sale \$699

This is top of the line Selig. You can see it in these stylish contemporary designs. You can see it in the outstanding quality of the fabrics. Rich velvets in designer motifs. Plush woven textures in earthtones. And right now, you can see it all at Englander's for 1/2 off. But only at Englander's. Naturally. Who else could buy up the best of Selig, while saving so much in the bargain? And of course, what we buy for less, you buy for less. That's what makes Englander's Buyer's Market Summersale (where you'll save 10% to 50% on everything) the best sale of the summer. 50 units available

Save 10% to 50% on everything!

**Englander's**

ENGLANDER TRIANGLE • BIRMINGHAM • ROYAL OAK • WESTLAND • ANN ARBOR (State Rd.)  
Store Hours: 10-9 Mon.-Fri. 10-5:30 Sat.  
Birmingham 10-9 Mon., Thurs., Fri., 10-5:30 Tues., Wed., Sat.  
Palm Beach and North Palm Beach (Worrell's)



# STANDARD FEDERAL SAVINGS

## A LONG RECORD OF CONTINUED GROWTH AND SERVICE.

### OUR SERVICES

Home Mortgage Loans  
Home Improvement Loans  
The Highest Interest Available  
with insured safety

#### 26-WEEK MONEY MARKET CERTIFICATE ACCOUNT\*

Minimum Balance \$10,000.00

**8.610%** Annual Interest

**8.921%** Effective Annual Yield,  
if reinvested at the same rate.

**\$435.28** Interest on \$10,000.00 after 26 weeks.

Rate in effect July 17 through July 23.\*\*

Interest on this account can be paid at maturity, paid monthly by check, or deposited monthly into a regular savings account which earns 5½% per annum.

#### 2½-YEAR MONEY MARKET CERTIFICATE ACCOUNT\*

Minimum Balance \$100.00

**9.50%** Annual Interest

**10.111%** Effective Annual Yield

Rate in effect through July 23.\*\*

Interest on this account is compounded continuously and paid quarterly into the account or by check. A Check-A-Month plan is also available with a minimum balance of \$5,000.00.

\*Federal regulations require a substantial interest penalty for early withdrawal from certificate accounts and prohibit the compounding of interest on 26-Week Money Market accounts.

\*\*The rate established at the time an account is opened is in effect for the full term of the certificate.

**Accounts now insured to \$100,000.00.**



**ANN ARBOR:**  
3200 Eisenhower Pkwy. at Packard  
7630 Jackson Ave. at Maple  
**BELLEVILLE:**  
186 Main at Second  
**BIRMINGHAM:**  
50 West Big Beaver near Woodward  
99 West Maple at Pierce  
3700 West Maple at Lahser  
31040 Lahser at 13 Mile  
**BLOOMFIELD HILLS:**  
825 W. Long Lake near Telegraph  
**BRIGHTON:**  
8516 E. Grand River near Chalis  
(Open Summer of 1980)

**CANTON TWP.:**  
44101 Ford Rd. near Sheldon  
**DEARBORN:**  
400 Town Center Dr. in the Financial Plaza  
**DETROIT:**  
405 Griswold at Jefferson  
**DETROIT—EAST:**  
14628 E. Jefferson at Manistique  
16530 E. Warren near Outer Drive  
11511 Kelly Rd. at Whittier  
**DETROIT—WEST:**  
17540 Grand River near Southfield  
25712 Grand River near Beech  
14221 Greenfield near Grand River  
10541 Joy at Manor

24224 Joy near Telegraph  
16841 Schaefer near McNichols  
**FARMINGTON HILLS:**  
35410 Grand River at Drake  
25950 Middlebelt at 11 Mile  
32920 W. 13 Mile at Farmington  
**GARDEN CITY:**  
5811 Middlebelt near Ford Rd  
**GROSSE POINTE WOODS:**  
19700 Mack Ave. near Cook  
**LIVONIA:**  
17230 Farmington near 6 Mile  
**MADISON HEIGHTS:**  
55 W. 12 Mile at John R.

**NOVI:**  
43600 West Oaks Dr. near I-96  
(Open Summer of 1980)  
**PLYMOUTH TWP.:**  
40909 Ann Arbor Rd. at Haggerty  
**ROCHESTER:**  
1310 Rochester near Avon  
**ROSEVILLE:**  
20695 12 Mile near Little Mack  
**ROYAL OAK:**  
1406 N. Woodward near 12 Mile  
**ST. CLAIR SHORES:**  
25515 Harper near 10 Mile  
**SHELBY TWP.:**  
4660 24 Mile near Shelby

**SOUTHFIELD:**  
29405 Greenfield near 12 Mile  
25123 Southfield near 10 Mile  
**STERLING HEIGHTS:**  
36909 Schoenherr at Metro Pkwy  
44100 Schoenherr at Lakeside Mall  
**TAYLOR:**  
10700 Pelham at Allen Rd  
**TROY:**  
2401 W. Big Beaver—Main Office  
2699 W. Big Beaver at Coolidge  
940 E. Long Lake at Rochester  
**VAN BUREN TWP.:**  
2069 Rawsonville near I-94

**WARREN:**  
3900 E. 14 Mile near Ryan  
30700 Schoenherr near 13 Mile  
**WATERFORD TWP.:**  
5619 Dixie at Cambrook  
**WAYNE:**  
35150 Michigan at Wayne  
**WEST BLOOMFIELD:**  
6120 W. Maple Rd. at Farmington  
**WESTLAND:**  
7957 N. Wayne at Nankin Blvd. N.W.  
315 S. Wayne near Cherry Hill  
**YPSILANTI:**  
123 W. Michigan at Washington

### OUR GROWTH 174th Semi-Annual Statement of Condition...June 30, 1980

#### ASSETS

First Mortgage Loans	\$ 98,879,411.57	
F.H.A. Insured	49,230,018.11	
G.I. Veterans Insured	2,473,148,179.60	\$2,621,257,609.28
Standard Mortgage Loans and Contracts		26,559,341.71
All Other Loans		226,487,264.79
Cash On Hand, in Banks and Federal Funds Loans		34,476,925.00
Investments and Securities		1,944,771.38
Real Estate Owned and in Judgment		2,177,928.91
Loans Made to Facilitate Sale of Real Estate		26,941,906.67
Standard Federal Savings Buildings and Equipment Less Depreciation		3,733,656.26
Prepaid Federal Savings and Loan Insurance Corporation Insurance Premiums		22,085,978.91
Other Assets		
<b>Total</b>		<b>\$2,965,665,382.91</b>

#### LIABILITIES AND NET WORTH

Savings Accounts	\$2,576,724,013.84
Advances From Federal Home Loan Bank	155,000,000.00
Other Borrowed Funds	4,801,065.40
Loans in Process	9,520,649.19
Deferred Credits	726,261.55
Other Liabilities	78,409,287.26
Specific Reserves	683,105.67
General Reserves	\$ 96,163,400.00
Surplus	43,637,600.00
<b>Total</b>	<b>\$2,965,665,382.91</b>

#### MILESTONES OF OUR GROWTH

ASSETS		SAVINGS	
1980	\$2,965,665,382	1980	\$2,576,724,013
1975	1,314,472,751	1975	1,175,656,818
1970	555,083,701	1970	497,856,274

#### COMPARATIVE HIGHLIGHTS

ASSETS		SAVINGS	
December 31, 1979	\$2,871,660,144	December 31, 1979	\$2,479,607,951
Growth from December 31, 1979 to June 30, 1980	94,005,238	Growth from December 31, 1979 to June 30, 1980	97,116,062
Assets June 30, 1980	\$2,965,665,382	Savings June 30, 1980	\$2,576,724,013

#### BOARD OF DIRECTORS

Robert J. Hutton, Chairman  
Thomas R. Ricketts, President

William H. Baldwin  
Harvey A. Kresge

Edward H. Lerchen  
Clare K. Morrison

John W. Paynter  
Walter J. L. Ray

Robert F. Weber  
Richard J. Wilson

#### WAYNE ADVISORY COMMITTEE

Kenneth A. McKay, Chairman  
Landy W. Box

Thorvald F. Marsh  
Harold L. Rediske

Harold Sleicher  
Nathan L. Weiser





Thursday, July 17, 1980

**The VIEW**  
from  
**CANTON CENTER**

WHEN DENNIS and Mary Beth Wrubel heard about the host couple arrangement planned for the Massachusetts delegates, they volunteered with a request for a specific couple. They said they would be responsible for the extra-curricular activities of Stanley and Helen Gillespie, delegates to the Republican National Convention from North Woburn, Mass.

The Gillespies are Mary Beth's uncle and aunt.

Members of the Massachusetts delegation are staying at the Plymouth Hilton in Plymouth Township. Delegates were paired with host couples who would look after their guests' recreational, shopping and sight-seeing preferences.

The Wrubels are planning a family reunion with her father and the rest of the family from Flint and Ann Arbor in attendance.

Mary Beth said her aunt and uncle loved the reception at the Mayflower Meeting House and the concert in Kellogg Park. "We were thrilled and the food was lovely."

"This is my first experience in politics and it is very interesting. My uncle



by  
**ELLIE GRAHAM**

is a Bush delegate. They just returned from a Lions Club convention in Chicago. He has a small business and his children run the business when they are away."

The Wrubels live on Maidstone Road in Canton Township. They have a son, Jamie, 6, and a daughter, Katie, 3.

"We have a big family reunion every year in Kentucky but my aunt and uncle have never seen Katie. They know Jamie. We lived in Massachusetts for a year and they sort of took us under their wing when we were there."

She offered to take her aunt to the big shopping centers but she replied, "No. I'm going to do all my shopping right here in Plymouth. My daughter said she wanted something that would last forever."

**NANCY AND PATRICK Sharp** are playing host to two couples, Republican State Chairman Andrew Natsios and his wife, Elizabeth, and political director of the Republican State Committee, Ron Kaufman and his wife, Alison.

The Kaufmans brought their 18-month-old daughter with them. The Natsioses left their 6-month-old daughter with their in-laws.

Elizabeth Natsios said this was their first national convention. As state committee chairman, they were invited to some special parties over the weekend. They attended Bill Brock's dinner party and reception at Meadow Brook Hall, and cruised up the Detroit River and into Lake St. Clair on a private yacht. They have been to Greenfield Village and loved it although "we didn't have time to see everything." They had been impressed with the RenCen, eaten at a Greek restaurant and were looking forward to the Stroh Brewery tour.

Monday was their first full day at the convention. Elizabeth said the air conditioning was perfect at Joe Louis Arena. "In fact, it was a little cool when we arrived in the morning but it was just right after all the bodies arrived."

They got back to the Plymouth Hilton about 12:30 a.m. They were going to leave earlier but couldn't get all their people collected.

**GILBERT AND SULLIVAN** had high scores for east-west in the July 2 duplicate bridge games at the Plymouth Cultural Center. Marion Sullivan gives Helen Gilbert top billing in the duplicate duo. North-south winners were Joan Andersen and Vince Matthews.

**VERNA WRISKA** and Virginia Wilke were winners at last Thursday's party bridge games at the Cultural Center. Virginia joins the group each summer when she comes to Michigan from the south to visit her family.

Margaret Swartz, who directs the games, will be vacationing in the Canadian west — Edmonton, Jasper, Lake Louise, Banff, Vancouver, Victoria — then up the inside passage for a cruise to Alaska. She'll be back in three weeks but the party bridge group will continue regular play in her absence.

**MR. AND MRS. ELDON Gregory** of 391 Sunset, Plymouth, recently celebrated their 45th wedding anniversary. They were married in Hasty, Ark. in 1935. The couple moved to Michigan in 1942 and they have been Plymouth residents for more than 25 years. They have three children, Betty Mikton of Northville, Kenneth Gregory of Can-

(Continued on page 2B)

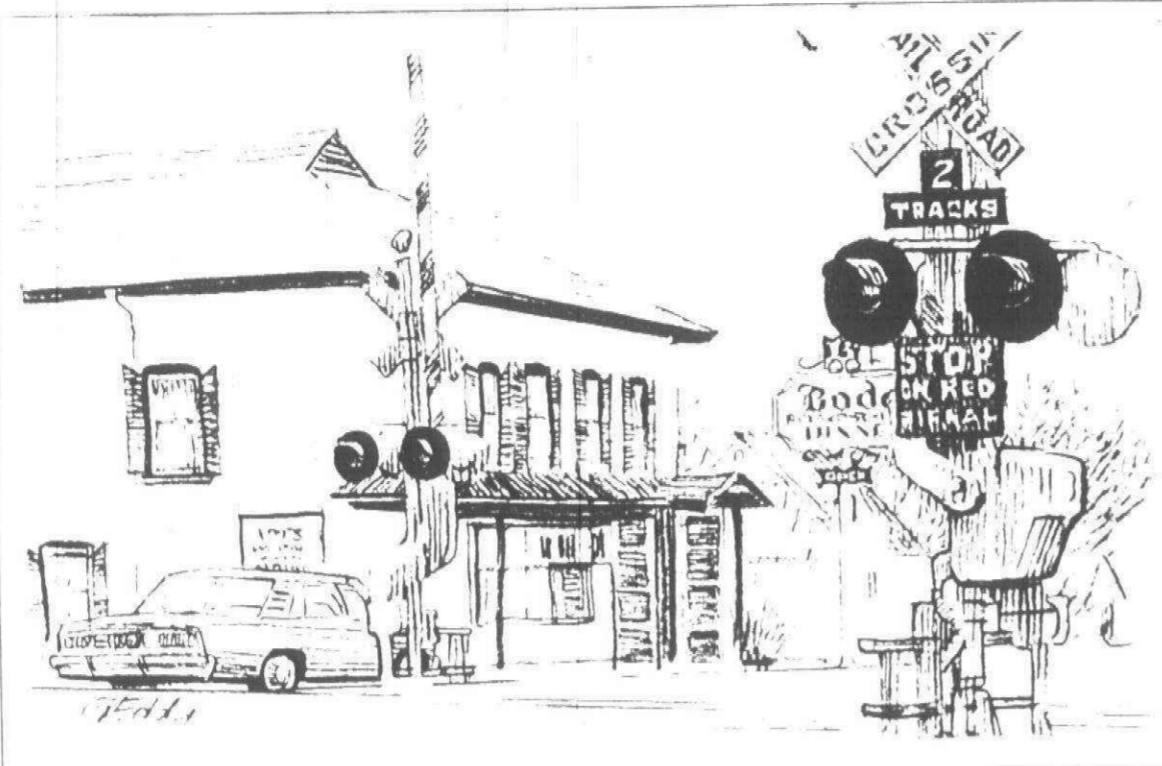

Main Street Crossing is by Gordon Eddy.

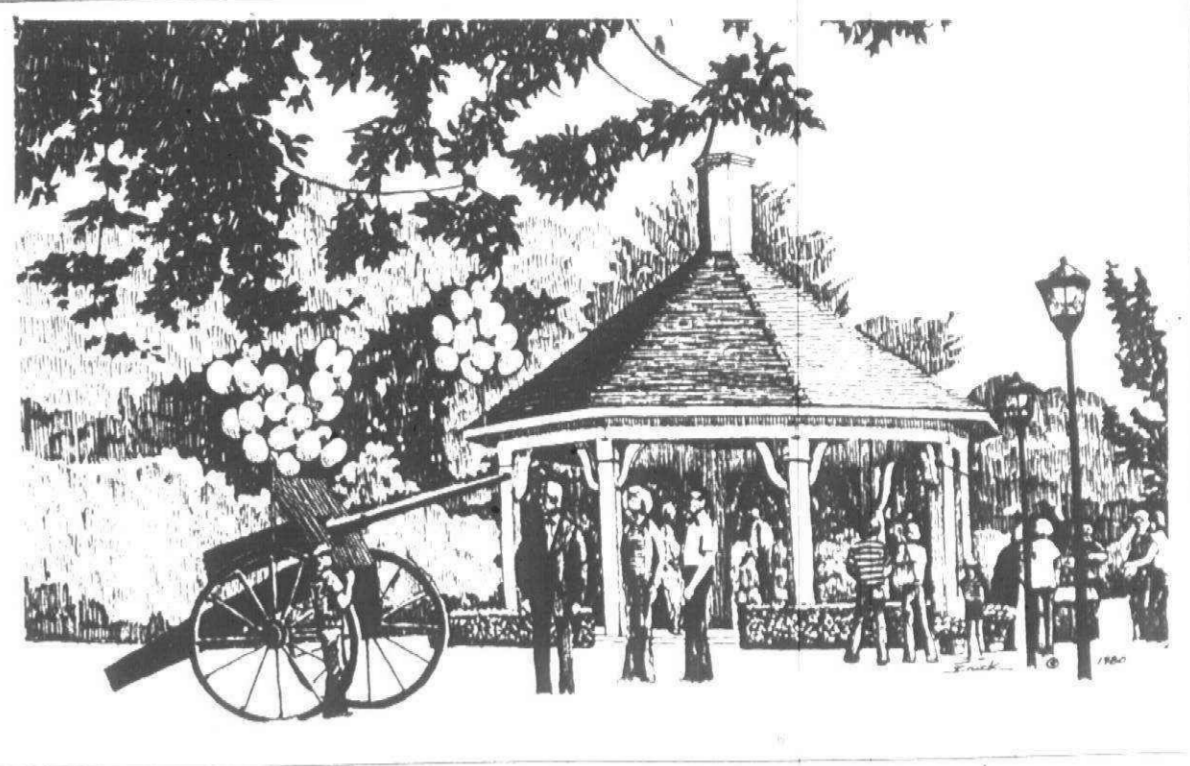

Gazebo is by F. Erick Carne.

# Original works of art on PCAC post cards

The works of nine local artists have been reproduced on heavy cream paper and the results are 10 new post-cards and a new fund-raiser for the Plymouth-Canton Community Arts Council.

The post card art series stemmed from an idea brought from Kansas to Michigan by the Traverse City Arts Council. The arts council board made the decision in late January to try the fund-raiser using the Carol Decker Memorial Fund as a starter. They hoped that enough money would be earned that the fund could in time support full-color reproductions of art works.

For the present, they would go with black ink. The women approached professional artists who live or work in the community. Each artist was given a commission to do something that typified the community to them. The media were pencil, pen and ink, photographs and watercolor washes.

The PCAC avoided artists who benefit from other arts council projects such as the Fall Festival Artist and Craftsman show.

**THE ARTISTS** are well known to the community and their drawings and photographs are of familiar landmarks.

Pam Wehmeyer contributed a photograph of the pink Victorian house on Main Street, next door to the library. Miss Wehmeyer is a Plymouth High School graduate and the daughter of Mark and Joan Wehmeyer. She works with William R. Biggs Associates, Inc.

F. Eric Carne, Plymouth architect and owner of the Old Village Gallery on Mill Street, did a pen and ink drawing of the gazebo on Farmer Street.

John Graham, Plymouth architect, did a pencil drawing of Kellogg Park.

Barbara Bray, commercial art teacher and Plymouth resident, sketched the Tonguish Creek walk and foot-bridge, adding a water color wash.

Thomas Gotts, Plymouth resident who teaches art in the Taylor School District, made a pencil drawing of the Main Street railroad crossing showing Bode's restaurant. He also contributed a drawing of an old coal and lumber company business by the tracks.

**GARY CASKEY**, news photographer for the Plymouth and Canton Observer newspapers, is a Canton Township resident. He came up with a photograph of a bank of hepaticas taken in Miller Woods in the spring. Miller Woods is owned by the Plymouth-Canton Community Schools. Caskey also has taught photography in PCAC-sponsored classes.

Tivadar Balogh, architect and Plymouth Township resident, contributed a pen and ink drawing of Growth Works on Main Street. Balogh designed the plans for the renovation of the youth center.

Damaris, commercial artist and teacher, used a grease pencil for her drawing representing the Plymouth Symphony Orchestra.

The artists turned in 5 1/2 x 3 1/4-inch originals. The printing was done by Graphic Communications on Junction Street in Plymouth.

The post cards are sold in packages of 10 for \$3 or separately for 30 cents each. The packages contain one of each design.

They are available at the following shops: Accent Bin, Beyers Drugs, Book World Volumes I and II, Charlie's Place, Colonial Card and Camera, the Green Thumb, Hillside Inn, Hugh Jarvis Gifts, Natural You Salon, Old Village Gallery, and Sideways.

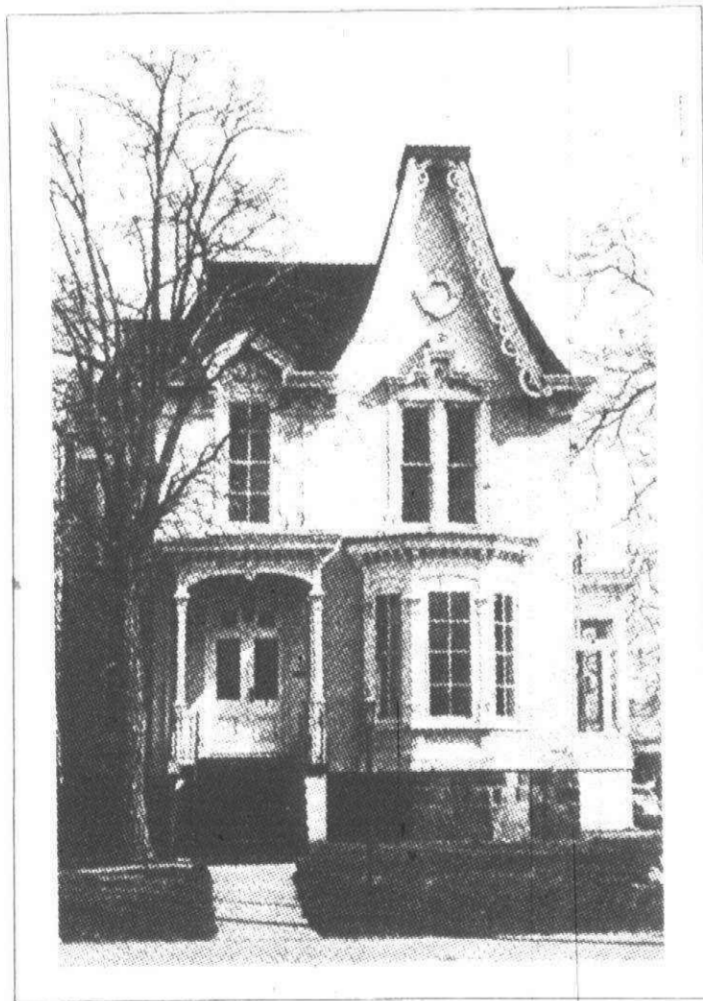

Photograph of pink Victorian house is by Pam Wehmeyer.

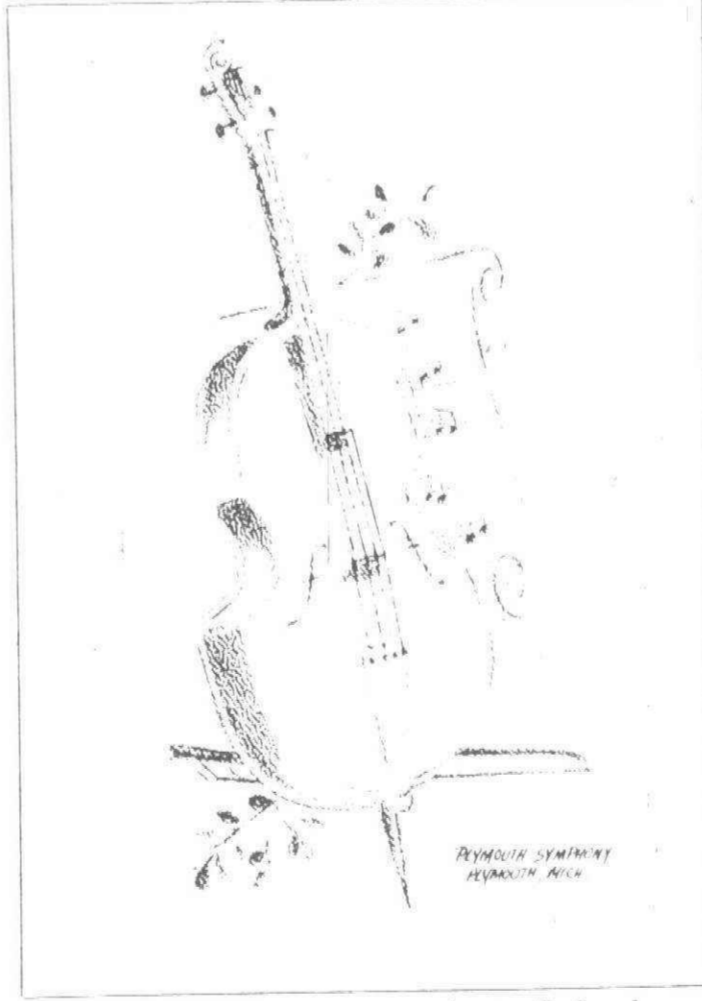

Damaris used a greased pencil for her Plymouth Symphony drawing.

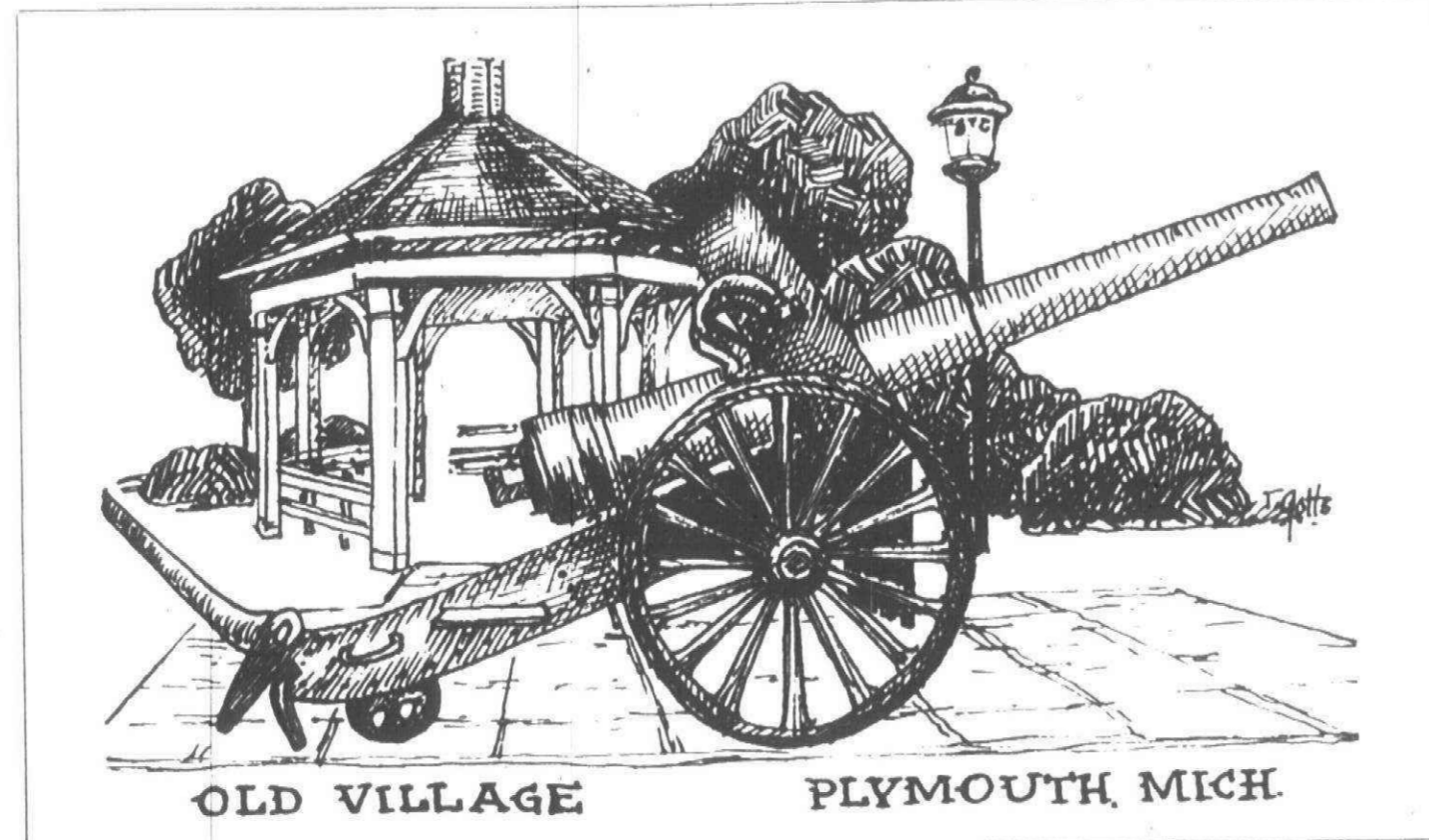

OLD VILLAGE PLYMOUTH, MICH.

Tom Gotts featured Cannon Park in Old Village.

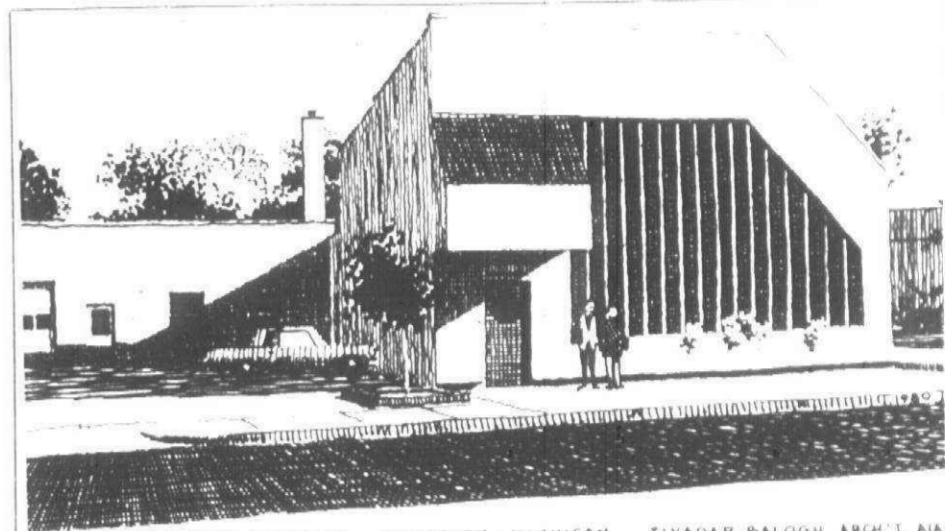

GROWTH WORKS BUILDING, PLYMOUTH, MICHIGAN TIVADAR BALOGH, ARCHT. AIA



TONGUISH CREEK PLYMOUTH, MICHIGAN

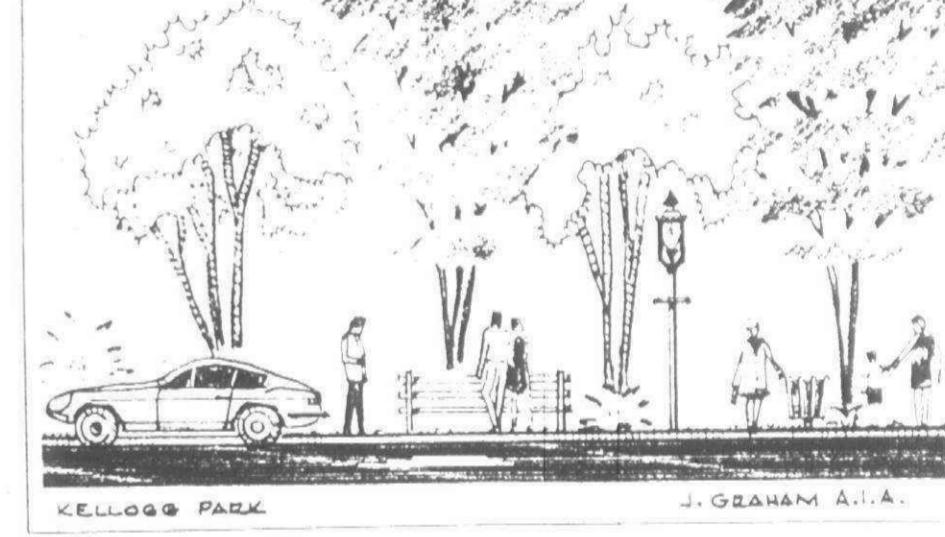

KELLOGG PARK J. GRAHAM A.I.A.

**Elvis Presley's Cadillac!!**

You'll enjoy seeing this stunning, 1973 Cadillac Eldorado. It was custom built and presented to Elvis on his 39th birthday by his father, Vernon.

**JULY**  
Wed, Thurs, Fri.  
**16, 17 & 18**  
OPEN 111 9pm

**While you're here, don't forget to:**  
★ Register for **FREE Elvis Concert Jacket** (Exact Reproduction)

also: **Rare FILM FOOTAGE of Elvis Concerts** plus other personal items of Elvis Presley, Clothing and Memorabilia on our showroom floor

Your Caring, Servicing, Selling Master Dealer

**Don Massey Cadillac**

933-2000  
Ann Arbor Rd. at I 275 Exit 28, Plymouth 453-7500

# Teenagers study law enforcement



Many things have come to my attention since I began writing Canton Chatter. I'm always glad to hear news of social events, clubs and travel highlights. Without this news, I would have to resort to a column about my everyday life in a dog-eat-dog household. With a German shepherd and a sheltie, the results here are usually quite predictable.

Luckily, for all of us, I have just learned of an interesting club, Explorer Post 214. This is a Law Enforcement Post for teenagers 15-19 years old with a serious interest in a career in law enforcement. The post is sponsored by the State Police on 7 Mile Road in Northville, under the directorship of Lt. William Tomczyk.

It would be very difficult, if not totally impossible, to find an advisor for any group more enthusiastic than Post 214's State Trooper Lorenzo Veal. He is extremely proud of his group and their accomplishments and the continuing work they do in area communities.

Linda Smith, a part-time probation officer, and Sue Holloway, a safety officer for the Plymouth Center for Human Development, also volunteer their time to work with the explorers.

These students are being trained in all aspects of police work. They have been on daily patrols and worked as store detectives. On Aug. 4-6 they will attend the Michigan State Police Academy for 146 hours of certified training in Law Enforcement.

### AND WHAT HAVE they done lately?

They did some security for "Expo '80 for Explorers" at the State Fair Grounds. Because of their help in finding a lost child there, they were chosen, along with several other explorer posts, to do some security at the Republican Convention. The explorers and Trooper Veal are very excited about this.

I would be too. Veal said it will be a white glove event. They will do such things as meet delegates at the airport and help them around the city. They will also escort delegates wives to various functions.

On June 25, this post co-hosted a picnic in Hines Park with the Al Hamba group for retarded children. They also helped with social events at Northville's Arbor Day celebration in early July. They have marched in numerous area parades.

Trooper Veal also emphasized that they are available for a color guard unit for concerts, sporting events, etc. They also will do security, in uniform, free for senior citizen functions, such as bingo. They want to be involved in the community, so if you are in a group that could use their services, call 348-1505 and ask to speak to the Explorer advisor.

Occasionally, they can use some financial assistance to help defray their expenses, so if you are in a group that would like to assist them, please feel free to call the same number.

THE MEMBERS of the Explorer post do have lots of fun together, in addition to learning about a law enforcement career.

They have several fun events planned for the summer to include a canoe trip. This works nicely into their physical fitness program.

The group has about 18 members, two of whom are from Canton. Sally and Molly Papay are excited about being part of the post's exciting activities.

The post will have a recruiting drive beginning in late August. They will be taking applications at the Michigan State Police Post in Northville. For more information, you may call 348-1505 and ask for the Explorer advisor. After an application is submitted, the police will speak with the candidate, school counselors and conduct a home interview.

After speaking with Trooper Veal, he has me almost as enthused about the program as he is. He said when he's not working with the scouts, he's "just a regular road trooper." So, I couldn't resist asking that if I should happen to get a ticket, could I drop his name?

He said I could, and it probably wouldn't hurt, but then again, it wouldn't help either. Hmmm...

### new voices

Mr. and Mrs. Robert Elliott of Erik Pass, Plymouth announce the birth of their daughter, Laura Christine, June 27, 1980 in St. Joseph Mercy Hospital, Ann Arbor.

Terry and Novella Whittaker of Edmuntson Street, Canton Township announce the birth of their daughter, Shannon Lynn, June 25, 1980 in St. Joseph Mercy Hospital, Ann Arbor. They have two older daughters, Kim, 13, and Annette, 7.

Grandparents are Mr. and Mrs. Richard Whittaker of Plymouth and Mr. and Mrs. Don McLung of Plymouth.

Caroline and David Logsdon of Owensboro, Ky., announce the birth of their first child, a son, Nathan Gray Logsdon, born June 3, 1980.

Grandparents are Al and Elizabeth Folger of Plymouth and Mr. and Mrs. Clyde Logsdon of Springfield, Ky.

### Looking ahead

Ashua Jain, (from left) Jennifer Croll, Debbie Dillon, Julie Fisher, and Trisha Short are preparing soft-sculpture puppets for the children's art section of the Artist and Craftsman Show which will be Sept. 6 and 7 in Central Middle School. The annual show is sponsored by the Plymouth Community Arts Council as part of the Plymouth Fall Festival. Susan Schrader is chairing the children's division which invites the young people to offer their handicrafts for sale at the show. All youngsters from the Plymouth-Canton Community may participate. For information, call the PCAC office, 455-5260 between 9 a.m. and noon, Monday through Thursday. (Staff photos by Gary Caskey)



### The VIEW

(Continued from Page 1B) ton, and Cheri Holman of Canton. They would like to assist them, please feel free to call the same number.

Mrs. Gregory retired from Burroughs Corp. in July. Her husband retired from Ford Motor Co. in December 1979. They just returned from a trip to Seattle, Wash. where they attended a Gregory family reunion.

**43rd Annual Summer Sale Now In Progress**

Since 1937

A Beautiful Store with Beautiful Furniture  
**MICHIGAN'S LARGEST PENNSYLVANIA HOUSE DEALER**  
America's most distinguished traditional furniture

**Colonial House**  
20292 Middlebelt Rd. (South of Eight Mile)  
Livonia  
Open Mon., Thurs. & Fri. Til 9 P.M. 474-6900

**SUMMER SALE NOW IN PROGRESS**

**YOUR COMPLETE FLOOR COVERING CENTERS**

• Linoleum • Carpet • Tile • Ceramic

**PLYMOUTH FLOOR COVERING**

Professional Floor Covering Service Since 1960

Expert Installation - Work Guaranteed

HOURS: Mon., Thurs., Fri. 9-9 Tues., Wed., Sat. 9-6

33811 PLYMOUTH ROAD 1180 ANN ARBOR ROAD  
1 block west of Farmington Rd. 1 block east of Sheldon  
427-7120 453-2444

**GARAGE DOOR OPENERS DO-IT-YOURSELF SALE**

**Genie** MODEL GS459D  
\$149.99  
Free Delivery  
1 Year Warranty

Installation available on openers purchased during sale at 20% off regular price.

**ALADDIN GENIE** Sales & Service  
Factory authorized service & installation.  
722-0610 335-9079

NORTHVILLE-NOVI WEST BLOOMFIELD  
PLYMOUTH-CANTON TROY-PONTIAC  
FARMINGTON-SOUTHFIELD ROCHESTER-BIRMINGHAM

**Smiley Brothers**

A TRUSTED NAME IN MUSIC

The finest keyboard products available!

- Baldwin pianos & organs
- Hammond & Allen organs
- Marantz Piano/organ "memory" pianos
- Young Chang grands & consoles
- Sabatini harpsichords
- Select used instruments

Rochester at 1449 N. Roch. Rd. 652-8238  
Birmingham at 1010 N. Hunter, MI 7-1177  
Also, Detroit & Dearborn

**Laurel FURNITURE**

**DESKS**  
ALL STYLES  
ALL FINISHES

584 W. Ann Arbor Tr. (Bet. Lilley Rd. & Main St.)  
PLYMOUTH 453-4700  
Open daily 9:30-6 PM Thurs. & Fri. 11-9 PM

**Saks Fifth Avenue**

Paul Schnell re-directs the suit for Ernst Strauss with a jacket shaped shorter, smaller in the texture-richness of teakwood Ultrasuede® a soft blend of polyester and non-fibrous polyurethane. A skirt in a fabulous blanket plaid of finest wool. And a blouse of creamy silk pongee gently bowed at the neck. For sizes 4 to 14; \$490. In Designer Coat and Suit Collections...where we are all the things you are. Join our special representative Thursday and Friday in Fairlane, and on Saturday in Troy for collection showing and informal modeling from 11 to 4.

Somerset Mall, Big Beaver at Coolidge, Troy • Fairlane Town Center, Dearborn

**Special Sale 1/3 to 1/2 Off**  
on all summer SPORTSWEAR by Jack Winter & Perception and DRESSES by Leslie Fay

Large Selection Bridal Gowns 1/3 to 1/2 OFF

**GeGe's** Mon., Thurs., Fri. 9:30-9  
Tues., Wed., Sat. 9:30-5

Bridal and Sportswear  
Livonia's First and Oldest Bridal Shop  
31188 Five Mile  
In Merri-Five Plaza—Livonia  
522-7540

**MATERNITY VOGUE**  
All Summer Stock Must Go!

**50%-75% off**

SHORTS, T-SHIRTS, SUMMER DRESSES, SUMMER PANTSUITS, SUMMER PANTS AND SUNDRESSES.

**PRE SEASON SWEATER SALE**  
**20% off**

SALE ENDS WED., JULY 23

7305 LILLEY AT WARREN CANTON 459-0260

**Getting settled made simple.**

New-town dilemmas fade after a **WEL-COME WAGON** call.

As your Hostess, it's my job to help you make the most of your new neighborhood. Our shopping areas. Community opportunities. Special at-actions. Lots of facts to save you time and money. Plus a basket of gifts for your family. I'll be listening for your call.

**Welcome Wagon**

CALL 356-7720

# ERA down, not forgotten

By MICHAEL W. REGULSKI

Monday's pro-ERA march and rally in downtown Detroit managed to light a fire under an otherwise lackluster, routine and admittedly choreographed political event.

Republicans gathering in Detroit to anoint their standard bearers this week were thrown off guard when an estimated 10,000 people marched to Cobo Hall to protest the GOP's recent dumping from its platform support for the Equal Rights Amendment to the Constitution.

ERA backers, singing "Are you sleeping, Are you sleeping, G-O-P, G-O-P n." and shouting "Ratify the ERA, Ronald Reagan go away," marched from the Kern Block to Cobo Hall to a rally in Kennedy Square, where their displeasure with the GOP's move overflowed onto Woodward and Lafayette avenues.

In the front line of the orderly demonstration was Michigan First Lady Helen Milliken, a strong ERA proponent who has vowed to continue to fight for women's rights despite the GOP rebuff.

The majority of the marchers wore white with purple or yellow sashes, symbolic of the suffragettes, and green and white "ERA Yes" buttons or patches.

AMONG THE groups taking their message to the streets were 11 members of the Plymouth branch of the

## Tour group celebrates anniversary

It was a time of reminiscing Saturday evening when 31 members of the group that flew to Plymouth, England, in 1970, had their first reunion.

The dinner party was in the Miles Standish Room of the Mayflower Hotel. They told and re-told the many stories of their part in helping the people of Plymouth, England, celebrate the 350th anniversary of the sailing of the Mayflower.

To augment the reciting of the memories by those at each table, Bruce Richard showed slides of the many places they had visited 10 years ago.

The program and the party were put together by a committee headed by Doris Richard. The Plymouth-to-Plymouth travelers agreed that they shouldn't wait another 10 years for a get-together.



Mary Uhl, member of the Plymouth branch of the American Association of University Women and a state AAUW official, is an outspoken supporter of ERA. (Staff photo)

American Association of University Women, led by Mary Uhl, branch president.

"I thought it (the turnout) was fantastic," said Mrs. Uhl, who added that she was unable to attend a May rally in Chicago and this gave her a chance to show her support locally for the ERA.

She said more than 200 AAUW members were on hand for Monday's march, including Dr. Nancy Joyner, AAUW national officer who is heading the group's national task force for the ERA.

Mrs. Uhl, who lives in Plymouth Township, expressed disappointment that former First Lady Betty Ford and Maureen Reagan, daughter of Presidential hopeful Ronald Reagan, did not attend. The two women have been strong ERA boosters.

"It's a sad thing as an observer looking in at how they all start playing politics and softening their stands," Mrs. Uhl said. "If people believe in something strong enough I've always felt they should stand up for it."

Janet Evans, a Farmington Hills resident and president of the Northwest Wayne County chapter of NOW, helped in organizing the coalition of groups that marched.

She said the national NOW organization originally hoped to attract 3,000-5,000 marchers. Like Mrs. Uhl, Mrs. Evans was pleased with the turnout.

Mrs. Evans said she doesn't see the GOP's move as a setback, however, she is concerned that gains like Title IX and changes in credit laws could possibly be rolled back.

Her impression from discussions with other members is that NOW is no where close to endorsing a candidate and the group is taking a wait-and-see attitude.

"I think they (the GOP) feel a little threatened," she said. "Depending on what poll you read . . . I don't think you can just ignore that many people (who favor ERA ratification)."

She said NOW is going to work at the "grass roots level" to help elect people who favor ratification. "It's an idea whose time has come, and it will eventually."

OTHER GROUPS represented were the North Oakland County chapter of the National Organization for Women, the American Association of University Women, the Association of Suburban People, the Business and Professional Women, Mormons for ERA, local, state, and national teacher organizations, several UAW groups, a YWCA contingent, a gay political group, and anti-nuclear energy forces.

Rally organizers also announced that Republican delegates made a strong showing.

Placards carried included one bearing a portrait of a saddened Abraham Lincoln. It asked, "Will the party that freed the slaves be the party to enslave women?" Others: "ERA is AmERiCAn" and "Reagan for Shah."

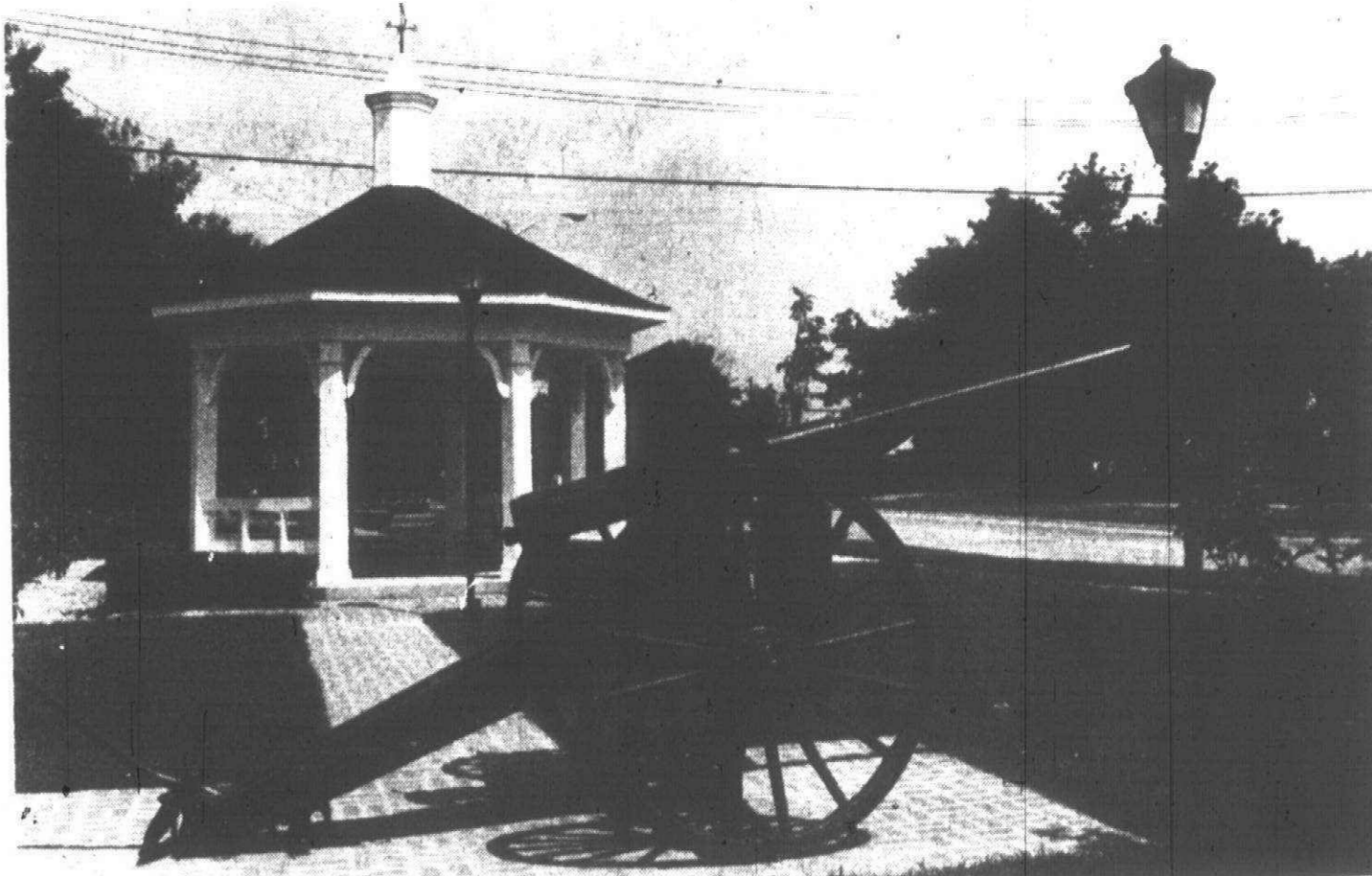

## Dearie Days headquarters

All was quiet earlier this week in Cannon Park in Old Village. But the park will be filled with people and activities Friday and Saturday for the ninth annual Dearie Days festival. Music and entertainment will be centered in the gazebo and visitors are asked to provide their own lawn chairs and/or blankets to

watch the proceedings. Farmer Street will be closed between Mill and Starkweather streets for the event. The whole Old Village area will be alive with flea markets, special bargains in the stores and wandering musicians, all with a Gay '90s flavor. (Staff photo by Gary Caskey)

**"The Rape of the Lock"**  
**SUMMER SPECIALS**

**\$3.00 OFF**  
 HAIRCUT, SHAMPOO & BLOW DRY  
 With Coupon Expires 7-31-80

**\$5.00 OFF**  
 PERMS & HENNAS with coupon  
 Expires 7-31-80

Bring the entire family  
 Everyone will get the discount

38407 Joy Road  
 Joy-Hix Center Westland

453-1717  
 appointments not always necessary

**Pools, Pool Accessories  
 Toys & Lounges  
 Get your inSPAration Now!  
 Hot Tubs**

**10% Off Sun Granular Chlorine**

**Liquid Chlorine 99¢ Gal.**

**Pietila Bros. Pool Service & Supply**

30735 GRAND RIVER  
 next to Tom Holzer Ford  
 across from A&W

DAILY 9-8  
 SUNDAY 9-4

FARMINGTON  
 478-4978

**Needle's Friend**  
 Summer Classes  
 Starting in August

Beginning Needlepoint, Continuing Needlepoint, Bar Gello, Smocking, Crochet & Knitting, Advanced Needlepoint, Counted Thread, Crewel, Punch Needle Embroidery.

Inquire on times & prices.  
 349 JOPPA PLACE  
 PLYMOUTH 455-8770

*Women's Alterations*  
*Personal Fittings*  
*Our service saves slacks*  
*Taper yesterday's slacks into today's fashions*

**Lapham's MEN'S SHOP**

Women's Fittings 9 to 5:30 Daily  
 Men's Fittings 9 to 6; Thurs. & Fri. to 9 pm  
 120 E. Main—Northville 349-3677

**Wings on Feet**  
 THE MUSICAL FOR THE 80's

**Northville's Downtown Theatre**  
 JULY 10 - AUGUST 3

For Information Call 335-8444  
 Northville, Michigan

**TROUBLED BY UNWANTED HAIR?**

Discover the new EP 2000. The EP 2000 is the most advanced electrolysis machine to date to PERMANENTLY remove unwanted hair forever. Previous scarring, pain, swelling and irritation associated with electrolysis have been virtually eliminated. The EP 2000 and our method of electrolysis is the FASTEST, SAFEST and most COMFORTABLE method of electrolysis developed.

**BELMONT OF LIVONIA**

TOWNE CENTER PLAZA  
 15195 FARMINGTON RD.  
 LIVONIA, MI 48154

APPT. TAKEN 9 AM - 2 PM  
 TUES.-FRI. EVENING  
 HOURS AVAILABLE  
 421-0990

**TELL YOUR FRIENDS**

... with an ad in our Classified columns. They're sure to read your message—whatever it may be—in Classified. We have the readers . . . we'll help you reach the right people, too!

**people read classified**

**Observer & Eccentric CLASSIFIED ADS**

644-1100 Oakland County  
 591-0900 Wayne County  
 852-3222 Rochester/Avon

# Act Now For Reduced Rate Auto Loans

If you have been thinking about a new auto purchase, right NOW is the time to buy. All during July, Security Bank is reducing its rate on new car loans to a 14.5% ANNUAL PERCENTAGE RATE. This reduced rate, plus the special rebate programs being offered by auto dealers, makes July the perfect time to purchase a new car. Our special rate is available at your local auto dealer, at any office of Security Bank, or by calling Phone-A-Loan® at 281-5070. Act now!

Typical example for a \$7,000 car, \$1,000 down, \$6,000 financed

Repayment Period	Special Rate 48 Months	Legal Rate 48 Months	Savings
Annual Percentage Rate	14.50%	16.50%	
Amount Financed	\$6,000.00	\$6,000.00	
Total Finance Charge	\$1,942.56	\$2,234.40	\$291.84
Monthly Payment	\$ 165.47	\$ 171.55	\$ 6.08
Total Loan	\$7,942.56	\$8,234.40	

**14.5% A.P.R.**

**SECURITY BANK & TRUST**  
 A Subsidiary of Security Bancorp, Inc. / Member FDIC

Security Bank and Trust has 29 conveniently-located offices serving Allen Park, Bingham Farms, Canton Twp., Ecorse, Lincoln Park, New Boston, Romulus, Southgate, Taylor and Ypsilanti Twp. or call 281-5000.

# Your Invitation to Worship

## BAPTIST

**FIRST BAPTIST CHURCH OF FARMINGTON**  
Richard Duncan, Pastor - Phone 474-0350

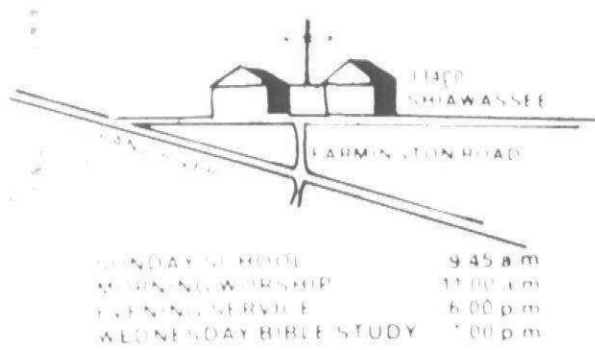

SUNDAY WORSHIP 9:45 a.m.  
MORNING WORSHIP 10:45 a.m.  
EVENING WORSHIP 6:00 p.m.  
WEDNESDAY BIBLE STUDY 7:00 p.m.

**MARANATHA BAPTIST CHURCH**  
Rev. James H. Russell, Pastor  
44815 Cherry Hill Rd., Canton, Mich.  
981-0895

**SERVICES**  
SUNDAY 9:45 a.m.  
FAMILY BIBLE SCHOOL 10:45 a.m.  
MORNING WORSHIP SERVICE 10:45 a.m.  
EVENING SERVICE 6:00 p.m.  
MONDAY AWANA CLUBS - Ages 5-13 9:45 p.m.  
WED BIBLE STUDY & PRAYER MEETING 7:00 p.m.

FUNDAMENTAL EVANGELISTIC GARBC

**Community Baptist Church**  
28237 W. WARREN  
Garden City  
Rev. James B. Allen, Pastor  
Sunday School - 10 a.m.  
Sunday Morning Service - 11 a.m.  
Sunday Evening Service 6 p.m.  
Mid-week Prayer Service 7:30 p.m.

**LIVONIA BAPTIST CHURCH**  
AFFILIATED WITH SOUTHERN BAPTIST CONVENTION  
32940 SCHOOLCRAFT 2 BLOCKS EAST OF FARMINGTON RD.  
422-3763  
PASTOR ELVIN L. CLARK  
Sunday School - 9:45 a.m.  
Morning Worship - 10:45 a.m.  
Baptist Training Union 5 p.m.  
Evening Worship Hour 7 p.m.  
Wednesday Service 7 p.m.

**MAIN STREET BAPTIST CHURCH**  
Affiliated with Southern Baptist Convention  
9451 S. MAIN, PLYMOUTH  
H. Thweatt, Pastor 453-4785  
Sunday School - 9:45 a.m.  
Morning Worship - 11 a.m.  
Baptist Training Union - 6:30 p.m.  
Evening Worship - 7:30 p.m.  
Wednesday Service - 7:00 p.m.  
DEAF MINISTRY

**CHRISTIAN SCIENCE**

**FOURTH CHURCH OF CHRIST SCIENTIST**  
24400 W. Seven Mile (near Telegraph)  
HOURS OF SERVICE  
11:00 A.M.  
SUNDAY SCHOOL 11:00 A.M.  
Nursery Care Provided  
WEDNESDAY TESTIMONIAL MEETINGS 8 P.M.

**ADVENTIST**

Plymouth Seventh Day Adventist Church  
4296 Maple Rd. (at W. Warren)  
Services: Saturday Sabbath School 9:30 Church Service 11:30  
A. Royce Snyman, Pastor  
Parsonage 459-2969

## PRESBYTERIAN

**WARD PRESBYTERIAN CHURCH OF LIVONIA**  
Farmington Road & Six Mile Road 422-1150

Worship & Sunday School 8:30, 10:00 & 11:30 a.m.

"Are You God's 'Missing Link' in Someone's Life?"  
Rev. L. Edward Davis  
7:00 p.m.  
"Life Unlimited" in Concert

Air Conditioned Sanctuary  
9:30 Sunday Service  
Broadcast WNUZ-FM 103.5  
Nursery Provided at All Services

**TRINITY PRESBYTERIAN CHURCH**  
(Branch of Ward Presbyterian Church, Livonia)  
Meeting at Isbister School - Canton Center Rd. south of Ann Arbor Rd., Plymouth

9:45 a.m. Sunday School for All Ages

11:00 a.m. Worship Service  
Message by Dr. Robert Woodburn  
Vice-President for Academic Affairs  
Detroit Bible College

Nursery Provided at Both Services  
For More Information Call 422-1150

**VILLAGE UNITED PRESBYTERIAN**  
25350 W. SIX MILE RD  
534-7740  
Dr. L. Peterson  
WORSHIP SERVICE 10:00 A.M.  
SUNDAY SCHOOL CHURCH SCHOOL 11:15 A.M.  
Nursery for both services.

St. Mark's Presbyterian  
26701 JOY RD  
Dearborn Hgts.  
Pastor John Jeffrey 278-9340

WORSHIP & NURSERY 10:00 A.M.  
Dial-A-Ride 278-9340

**ST. PAUL'S UNITED PRESBYTERIAN CHURCH**  
27475 Five Mile Rd. (at Inkster) 422-1470

SUNDAY BIBLE STUDY - 8:30 A.M.  
WORSHIP & CHURCH SCHOOL - 10:00 A.M.  
"KING OF THE MOUNTAIN"  
Dr. Wm. Whittedge  
William F. Whittedge and Robert G. Armstrong, Ministers

**FIRST UNITED PRESBYTERIAN CHURCH**  
PLYMOUTH, MICHIGAN  
Corner of Church and Main - 453-6464  
WORSHIP SERVICES  
Summer Worship & Church School 10:00 A.M.  
PHILIP RODGERS MAGEE, Minister  
THOMAS H. COOK, Asst. Minister  
"We have been contemporary since 1835"

**ROSEDALE GARDENS UNITED PRESBYTERIAN CHURCH**  
Hubbard at W. Chicago 422-0494  
Francis Henderson, Pastor Carol J. Allen, Pastor

8:30 & 10:00 A.M.  
"THE GATE OF THE LORD"  
Guest Pastor  
CHURCH SCHOOL 10:00 A.M.

**LUTHERAN WISCONSIN**

**Wisconsin Evangelical Lutheran Churches**  
WISCONSIN LUTHERAN RADIO HOUR  
1090 Sunday 10:00 a.m.

In Livonia: St. Paul Ev. Lutheran Church, 17801 Farmington Rd. Pastor: Wilfred Koeniger, 453-8759. Worship Services: 8:30 a.m. & 11 a.m.  
In Plymouth: St. Peter Ev. Lutheran Church, 1343 Penman Ave. Pastor: Leonard Koeniger, 453-3991. Worship Services: 8 & 10:30 a.m. • Sunday School: 9:30 a.m.  
In Redford Township: Holy Spirit Ev. Lutheran Church, 14750 Knoch. Pastor: Edward Zell, 532-8656. Worship Services: 8:30 a.m. & 11 a.m. • Sunday School: 9:45 a.m.  
In Westland: Our Savior's Lutheran Church, Warren at Farmington Rd. Vacantly Pastor: Karl Vetter, 422-6930/427-8178. Sunday School: 9:15 a.m. Divine Worship: 10:30 a.m.

**GARDEN CITY PRESBYTERIAN CHURCH**  
1841 Middlebelt Rd. Gareth D. Baker, Pastor 421-7620

SUNDAY SERVICE 10:00 A.M.  
"A DIFFICULT QUEST"  
CHRISTIAN CLASSES  
SUNDAY SCHOOL 10:00 A.M.  
Nursery Provided

St. Mark's Presbyterian  
26701 JOY RD.  
Dearborn Hgts.  
Pastor John Jeffrey 278-9340  
WORSHIP & NURSERY 10 A.M.  
Dial-A-Ride 278-9340

UNITY OF LIVONIA  
1806 E. Fairview  
421-1176  
SUNDAY 10:00 & 11:30 A.M.  
Dial a Thought 261-2440

## NON-DENOMINATIONAL

**WORSHIP & SERVE**  
with THE SALVATION ARMY  
290 Fairground Plymouth  
453-5464

SUNDAY SERVICES  
9:45 a.m. Sunday School  
10:00 a.m. Morning Worship  
6:00 p.m. Evening Worship  
Lt. Bill Harfoot, Officer

**AGAPE CHRISTIAN CENTER**  
of Plymouth  
Meeting at Masonic Building  
Penman Ave. Downtown Plymouth  
Full Gospel • Non-Denominational • Charismatic

10 A.M. ADULT WORSHIP  
YOUTH CHILDREN'S CHURCH 6 P.M. Worship  
WED 7:30 P.M. Family Teaching  
459-6240  
Agape Means The Good Kind of Love

**WESLEYAN**

**WARRENWOODS WESLEYAN**  
6615 Venoy, Westland 48185  
425-1170  
SUNDAY SCHOOL 10:00 A.M.  
WORSHIP 11:00 A.M.  
LIFE CONFERENCE 4:00 P.M.  
PASTOR HARRY WINGAR

**REFORMED CHURCH IN AMERICA**

**People's Church**  
PLYMOUTH-CANTON HIGH SCHOOL  
8415 Canton Center Rd.  
Rev. Harvey Heneveld  
Phone: 981-0499

July 20  
10:00 A.M.  
"LIVING BY GOODNESS AND FAITHFULNESS"  
Nursery Available  
Reformed Church in America

**CHURCH OF THE SAVIOR**  
Reformed Church in America  
Rev. GERALD DYKSTRA, Pastor  
WORSHIP SERVICE-9:30 A.M. (Nursery Provided)

Chinese Bible Study; Rev. Moody Yap, Leader (First and Third Friday, 8:00 P.M.)  
38100 Five Mile Road West of Newburgh 464-1062 Livonia

**CHURCH OF THE NAZARENE**

**PLYMOUTH CHURCH OF THE NAZARENE**  
41550 E. ANN ARBOR TRAIL PLYMOUTH 453-1525

The Difference is Worth the Drive

9:45 A.M. SUNDAY SCHOOL  
11:00 A.M. MORNING WORSHIP

6:00 p.m. SOUND OF SUNDAY NIGHT  
WED. 7:00 P.M. MidWeek Service  
Nursery Provided at All Services

**DETROIT FIRST CHURCH OF THE NAZARENE**  
(NOW WORSHIPING AT)  
30623 W. TWELVE MILE RD. FARMINGTON HILLS, MICHIGAN  
REV. JAMES D. CONNER

9:45 A.M. CHRISTIAN ED.  
11:00 A.M. WORSHIP SERVICE  
8:30 P.M. PRAISE & WORSHIP WEDNESDAY  
7:00 P.M. PRAYER & SHARE  
NURSERY FACILITIES AVAILABLE

WATCH FOR OUR NEW CHURCH AT I-275 AND 8 MILE ROAD  
CHURCH PHONE 477-2525

**BETHEL BAPTIST TEMPLE**  
29475 W. Six Mile, Livonia

H.L. Petty  
Pastor  
525-3664  
261-9276

Sunday School 10:00 a.m.  
Morning Worship 11:00 a.m.  
Evening Service 6:00 p.m.  
Wed. Family Hour 7:30 p.m.

News Release JULY 20  
11:00 A.M. "WORTHY IS THE LAMB"  
6:00 P.M. GUEST: REV. JERRY HICKEY  
AUG. 4-7, JR. & JR. HIGH CAMP

"A Church That is Concerned About People"

DISCOVER THE DIFFERENCE at **BEREAN BIBLE CHURCH**  
35375 ANN ARBOR TRAIL, LIVONIA  
425-5585 (Between Wayne & Newburgh) 522-9386

Roland F. De Renzo, Pastor

MORNING WORSHIP 10:00 a.m.  
BIBLE SCHOOL 11:15 a.m.  
EVENING SERVICE 6:00 p.m.  
WEDNESDAY SERVICE 7:00 p.m.  
VISUALIZED CHILDREN'S CHURCH 10:00 a.m.  
holding forth the word of life

**GRAND RIVER BAPTIST OF LIVONIA**  
4500 SIX MILE RD. Just West of Farmington Rd.  
9:30 A.M. Family Sunday School TO ENJOY  
10:45 A.M. DR. HOMER ARMSTRONG

NURSERY OPEN  
Adriana Chaney, Min.  
of Christian Ed. & Youth  
Pastor  
Dr. Wilbert D. Gough  
261-6950

**EVANGELICAL COVENANT CHURCH OF AMERICA**

**FAITH COVENANT CHURCH**  
Pastor: Michael A. Halleen  
Associate Pastor: Mary Miller Vikander  
Minister to Youth: David A. Rose  
35415 W. 14 Mile Rd. at Drake 661-9191

SUNDAY SCHOOL AND SUNDAY WORSHIP 10:00 A.M.

**FIRST UNITED METHODIST OF PLYMOUTH**  
3420 N. TERRITORIAL RD. (at East of Sheldon)  
SUNDAY OFFICE HOURS 9:5 MON. THRU FRI. 453-5285

WORSHIP SERVICE & CHURCH SCHOOL 9:30 A.M.  
John N. Grenfell, Jr.

Frederick C. Vosburg  
Parish Minister

**CLARENCEVILLE UNITED METHODIST**  
20300 Middlebelt Livonia  
Pastor Gerald Fisher 474-3444

8:45 a.m. First Worship Service  
10:00 a.m. The Church School  
11:15 a.m. Second Service of Worship

6:00 p.m. Youth Meetings  
7:30 p.m. Wed-The Midweek Service

Nursery Provided at All Services

**ALDERSGATE UNITED METHODIST CHURCH**  
(Redford Township)  
10000 BEECHDALE ROAD  
Between Plymouth and West Chicago  
Rev. Archie H. Domigan  
Korean Minister Cho. Yu Hon  
Korean Chapel Service 11:00 A.M.  
Worship Services & Church School 9:30 a.m.  
Minister of Music: Ruth Hadley Turner

**LIVONIA LUTHERAN CHURCHES WELCOME YOU**

**SWORD OF THE SPIRIT - ALC**  
34563 W. 7 Mile Road  
Worship - 10:00 A.M.  
476-3818

**HOLY TRINITY LUTHERAN CHURCH - AELC**  
39020 Five Mile Road  
Worship - 8:30 & 10:00 A.M.  
464-0211

**ASCENSION LUTHERAN CHURCH - ALC**  
35301 Five Mile Road  
Worship - 10:00 A.M.  
464-8081

**ALL SAINTS LUTHERAN CHURCH - AELC**  
8850 Newburgh Road at Joy  
Worship - 9:30 A.M.  
427-9575

**HOLY CROSS LUTHERAN CHURCH - LCA**  
30650 Six Mile Road  
Worship - 9:30 & 11:00 A.M.  
427-1414

**FAITH LUTHERAN CHURCH - AELC**  
30000 Five Mile Road  
Worship - 8:15 & 10:45 A.M.  
421-7249

**CHRIST THE KING LUTHERAN CHURCH - LCA**  
9300 Farmington Road  
Worship - 9:00 A.M.  
421-0749

**TIMOTHY LUTHERAN CHURCH - ALC**  
8820 Wayne Road  
Worship 8:30 & 10:00 A.M.  
427-2290

**EPISCOPAL**

**SAINT ANDREW'S EPISCOPAL CHURCH**  
16360 Hubbard Road Livonia, Michigan 48154  
421-8451  
8:00 A.M. Holy Eucharist  
9:00 A.M. Christian Education Classes  
10:00 A.M. Family Eucharist  
Sunday Morning - Nursery Care Available  
10:30 A.M. - Wednesday Eucharist

The Rev. Kenneth S. Davis The Rev. R. Scott Kropel  
The Rev. Edward A. King

**HOLY SPIRIT, LIVONIA**  
9083 Newburgh Rd. Livonia  
591-0211 522-0821  
Sermon and Eucharist  
9:30 A.M.  
Nursery Available  
The Rev. Emery Gravelle

**NATIVITY CHURCH**  
Henry Ruff at West Chicago Livonia  
421-5408  
Worship & Church School 10:00 a.m.  
Dr. Robt. H. Jacobson

LUTHERAN MISSOURI SYNOD

CHRIST OUR SAVIOR LUTHERAN CHURCH
MISSOURI SYNOD
14175 Farmington Rd. 1/4 Mile N. of Schoolcraft
REV. RALPH G. SCHMIDT, PASTOR
WORSHIP SERVICES EVERY SUNDAY 8:00 & 10:30 A.M.
SUNDAY SCHOOL 9:15 A.M.

LUTHERAN CHURCH OF THE RISEN CHRIST
MISSOURI SYNOD
46250 ANN ARBOR ROAD
PLYMOUTH
Kenneth Zielke Pastor
453-5252 453-1099
Sunday Worship 9:00 a.m.-10:45 a.m.
Bible Study & Sunday School 9:00 a.m.

GRACE LUTHERAN CHURCH-MISSOURI SYNOD
25630 GRAND RIVER at BEECH DALY
REDFORD TWP
537-2766
SUNDAY SERVICES SUNDAY SCHOOL
9:15 & 11:00 A.M. 9:15 & 11:00 A.M.
Rev. V. F. Halboth, Jr., Pastor
Rev. Victor F. Halboth, Sr., Pastor Emeritus
Mr. Mark Matthews, Dir. of Christian Education

SALEM EV. LUTHERAN CHURCH
32430 ANN ARBOR TRAIL
WESTLAND
Rev. Paolo Frusti
Ch 525-4538 422-5550
10:00 A.M. DIVINE WORSHIP
9:00 A.M. SUNDAY SCHOOL & BIBLE CLASS

ST. MATTHEW LUTHERAN Church & School
5885 Venoy
1 Bk N of Ford Rd Westland
425-0260
Ralph Fischer, Pastor
Charles F. Buckhahn, Asst Pastor
Divine Worship 8 & 11 a.m.
Bible Class & SS 9:30 a.m.
Monday Evening Service 7:30 p.m.

St. Paul's Lutheran Missouri Synod
20805 Middlebelt at 8 Mile Farmington Hills 474-0675
The Rev. Ralph E. Unger, Pastor
SUNDAY WORSHIP 8:30 AM & 11 AM
SUNDAY SCHOOL 9:45 AM ADULT BIBLE CLASSES 10 AM
CHRISTIAN SCHOOL Grades K-8
Wayne C. Berkesch, Principal
474-2488

ASSEMBLIES OF GOD

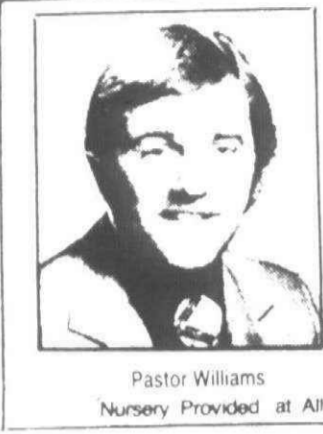

UNITED ASSEMBLY OF GOD
42021 E. Ann Arbor Trail Plymouth, MI
Pastor, Jack Williams - Mark Warde, Asst. Pastor
SUNDAY
10:00 A.M. SUNDAY SCHOOL
11:00 A.M. MORNING SERVICE
Rev. John Walaskay
6:30 P.M. EVENING SERVICE
Pastor Mark Warde
WEDNESDAY
7:15 P.M. FAMILY NIGHT
Adult Bible Study Petra Youth Ministries
Nursery Provided at All Services
Welcome to Our Father's House

CHRISTIAN COMMUNITY CHURCH
41355 Six Mile Rd. Northville 348-9030
11:00 A.M. 'THE GREAT REFUSAL' Pastor Mitchell
6:30 P.M. Pastor Hanson Will Minister
WEDNESDAY 7:30 P.M. FAMILY NIGHT
Nursery Available

TRI-CITY ASSEMBLY OF GOD
2100 HANNAN ROAD WAYNE, MICHIGAN 721-6832
11:00 A.M. & 7:00 P.M. Pastor Raimer
Jesus Loves You and So Do We
Serving Wayne, Westland and Canton

BETHEL MISSIONARY ASSEMBLY OF GOD
8900 MIDDLEBELT NORTH OF JOY RD
A CHARISMATIC GROUP
SUNDAY SERVICES 9:45-10:45 A.M. 6:30 P.M.
THURS. 7:00 P.M.
PASTORS
J.J. TRAUB
M. TYLER
261-1957 or 421-9140

LUTHERAN CHURCH IN AMERICA

ST. MICHAEL LUTHERAN
7000 Sheldon Rd. Canton
459-3333
Pastor Jerry Yarnell
Intern Pastor Kathy Batell
WORSHIP 8:30 & 11:00 A.M.
SUNDAY SCHOOL 9:30 A.M.
Nursery Provided

APOSTOLIC

APOSTOLIC CHURCH OF JESUS CHRIST
993 N. HOLBROOK, PLYMOUTH
455-4861/334-6040
PASTOR C. T. GRAY
SUNDAY SCHOOL 10 A.M.
SUNDAY EVANGELISTIC 7 P.M.
WED. EVE BIBLE STUDY 7 P.M.
'The Church On The Rock' Matt: 16-18

CHURCHES OF CHRIST

LIVONIA
15431 Merriman Rd.
SUNDAY WORSHIP 11:00 A.M. & 6:00 P.M.
Rob Robinson Minister
427-8743
See Herald of Truth
TV Channel 20 Sunday 9:30 a.m.
Call or Write for Free Correspondence Course

EPHAPHY LUTHERAN LCA
41390 Five Mile Rd
420-0677
(Five Mile West of Haggerty Rd.)
Fred Prezzioso, Pastor
420-0568
Morning Worship 10:30 a.m.
Nursery Provided

BETHLEHEM LUTHERAN CHURCH
35300 Eight Mile Rd. Farmington Hills
LOWELL L. ANDERSON, PASTOR
Church 478-6520, 474-2579
Worship 10:00 A.M.
Bible Study
Bible Story Hour 9:00 A.M.

MEMORIAL CHURCH OF CHRIST

MARK McGILVREY, Minister
CHUCK EMMERT
Youth Minister
BIBLE SCHOOL
(All ages) 9:30 a.m.
Morning Worship 10:45 a.m.
Evening Worship & Youth Meetings 6:30 p.m.

CATHOLIC CHURCHES

ST. JOHN NEUMANN Parish
44800 Warren Road
455-5910
Fr. Edward J. Baldwin, Pastor
Masses
Sat. 5:00 and 6:30 pm
Sun. 8 a.m., 9:30 a.m.
11:00 a.m. and 12:30 p.m.

ST. THOMAS a' BECKET Parish
42424 Castle Court
981-1333
Fr. Ernest M. Porcari, Pastor
Masses at Mildred Field School
1000 Haggerty Rd. South of Cherry Hill
Sat. 6:00 p.m.
Sun. 9:00 a.m., 10:30 a.m. and 12:00

UNITED CHURCH OF CHRIST

SALEM UNITED CHURCH OF CHRIST
Oakland at Grand River Farmington
Church School
Divine Worship 9:00 a.m.
Church Office 474-6880
Rev. James A. Nelson, Min.
Parsonage 474-2944

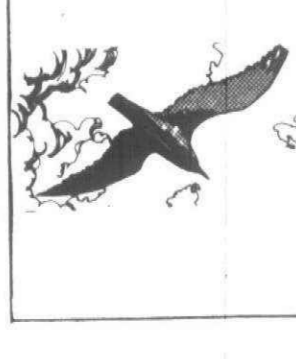

FOR CHURCH ADVERTISING
CALL VEL ELLIS
591-2300 Ext. 281

Bible school teaches songs and stories

While most vacation Bible schools stick to crafts and stories for youngsters, the one at the Rosedale Garden United Presbyterian Church, Hubbard at W. Chicago in Livonia, also is planning activity for parents during its July 21-25 sessions.

The school will run 9:30 a.m. until noon each day. While the kids study the Bible, listen to music and work on crafts, their parents can join the Rev. Carol Allen for discussions 10:30 a.m. to noon. The theme to be explored by the adults is "Who Said It Would Be Easy?"

The Bible school is for children of kindergarten age through sixth grade, and is directed by Linda Weed and her staff of volunteers of all ages. Registration is July 20 in the reception area near the parking lot. A fee of \$1 per child will be charged for curriculum materials.

One of the special treats for participants at the Bible school to be sponsored July 21-25 by the First Baptist Church of Garden City, 30268 Marquette, Garden City, will be a wiener roast on the closing day of the session. These classes will be held in the evening, and feature crafts, songs and refreshments.

Hours are from 6:30-8:30 p.m. and people from 2 years old to adults are invited.

"God's Happy People" is the theme at the Bible school of the Grace Lutheran Church, Grand River and Beech



Open wide, Jim Huggins. That's a big sandwich to get your jaws around. (Staff photo by Bill Bresler)

Daly in Redford Township. To take place from July 21-31, the Bible school is open to children from 3 to those going into eighth grade. Hours are from 9-11:45 a.m.

Activities are geared to different age groups, but generally include time for worship and Bible study, crafts, sing-

longs, contests and a parade. The program is directed by the Rev. V.F. Halboth, pastor, and Mark Matthews, director of Christian education.

For more details call the church at 535-1840.

The theme will be "Jesus, Lord and Savior" at the vacation Bible school at

Holy Trinity Lutheran Church, 39020 Five Mile, Livonia. The activities are offered to all the children in the community, 3-year-olds through sixth graders July 28-Aug. 3. Hours are from 9:30-11:30 a.m.

Registration will be on the first day of class.



Fourteen hungry mouths are waiting to take a bite of this over-sized submarine sandwich made by a vacation Bible school class at Clarenceville United Methodist Church. (Staff photo by Bill Bresler)

church bulletin

ST. PAUL LUTHERAN CHURCH, 17810 Farmington, Livonia, will conduct ordination and commissioning services for the Rev. David J. Farley at 4:30 p.m. Sunday.

Officiating for the ordination rite will be the Rev. Robert Hartman, mission counselor for the Michigan District of the Wisconsin Evangelical Lutheran Synod. The Rev. Winfred Koel-pin, pastor of St. Paul, will serve as lit-urgist.

Rev. Farley has been called by the Wisconsin Evangelical Lutheran Synod to organize a new Lutheran congregation in the Novi area and serve as its pastor. Worship services for the new congregation, to be known for now as the Novi Area Lutheran Church, are scheduled to begin early in September.

Rev. Farley was educated at Northwestern College in Watertown, Wis., and completed his graduate studies at Wisconsin Lutheran Seminary, Mequon, Wis. in May 1980. He served

ministerial internships at St. John Lutheran Church in Clare, Mich. and at Zebaoth Lutheran Church in downtown Milwaukee.

CANTON CALVARY ASSEMBLY OF GOD, 7933 Sheldon, will host one of America's top gospel songwriters, Gordon Jensen, at its 11 a.m. worship service Sunday.

Jensen, an ordained minister in the Assemblies of God, appears before audiences of up to 200,00 a year in church and concert settings. At 28 he has written and published more than 200 songs, many of which have been recorded by Christian artists.

ST. PAUL PRESBYTERIAN CHURCH, 27475 Five Mile, Livonia, has scheduled its annual family church camp on July 18, 19 and 20 at Groveland Oaks near Mt. Holly. For more information or to register call Dick Jerolman at 425-5475.

ST. JOHN BOSCO CHURCH, 12170 Beech Daly, Redford Township, is planning a retirement party for the Rev. Leo Sheltreau Thursday, July 31 in Vladimir's restaurant, Grand River and Eight Mile. Fr. Sheltreau is retiring July 31. The reception will start at 7 p.m., the dinner at 7:45 p.m. Tickets are \$16 per person and 700 will be sold on a first-come, first-served basis. To make a reservation, mail a check to Retirement Party, at the church.

FIRST BAPTIST CHURCH, 45000 Territorial, Plymouth, will hear a talk by the Rev. Theodore Johnson at the 11 a.m. worship service Sunday. He was the pastor of the Michigan Avenue Baptist Church in Saginaw, and is the father of a member of the congregation, Audrey Harrison.

WARD PRESBYTERIAN CHURCH, Farmington and Six Mile, Livonia, will present a concert by Life Unlimited at 7 p.m. Sunday. It will include the traditional hymn, contemporary music and an appearance by muppets for the children. The nine vocalists are selected from nationwide auditions, and give one of more years to this ministry. During its two year history, the group has given more than 400 concerts and recorded 10 albums. David Clydesdale, founder and director of the group, is on the staff of Singspiration Music.

Poetry prize will be \$1,000

A \$1,000 grand prize will be awarded in the sixth annual poetry competition sponsored by the World of Poetry, a quarterly newsletter for poets.

Poems of all styles and on any subject are eligible to compete for the grand prize or for 49 other cash or merchandise awards.

Says poetry editor Eddie-Lou Cole, "We are encouraging poetic talent of every kind, and expect our contest to produce exciting discoveries — like Virginia Bates, a housewife from Woodbine, Maryland. She won our grand prize last year with her poem, Pieta."

Farmington holds farmers' market

A farmers' market is open from 9 a.m. until noon each Saturday through October at the Farmington Community Center, 24705 Farmington, north of 10 Mile.

Items for sale, rain or shine, are fruits, vegetables, eggs, honey, flowers, plants, herbs and homemade baked goods.

Feeding the hungry

Staff members of Madonna College helped feed the hungry of Detroit's Cass Corridor as part of a food program at St. Patrick Church in Detroit. Federal tax money paid for the meal prepared here by Sr. M. Bridget Roznowski, (left) chairwoman of Ma-

donna's Humanities department; Dr. Charlotte Neuhouser, professor, and Dr. Ernest Nolan (right) of Livonia, chairman of humanities. Twelve gallons of spaghetti sauce were donated by the Leather Bottle Inn.



# Sonia Johnson calls for equality

By SHIRLEE IDEN

Blue jean clad, Sonia Johnson strode into Metropolitan Airport after an all night flight from Seattle to Chicago to Detroit.

Wouldn't it have been easier to fly directly from Seattle to Copenhagen for the UN International Women's Decade meeting she was headed for?

Sure, but the Republican Platform Committee last week knocked the Equal Rights Amendment out of their 1980 platform, and when you take a swipe at the ERA, you hurt Sonia Johnson where she lives.

She came to the area to participate in a demonstration for ERA by Women in Communications, YWCA, Business and Professional Women's Association, and a number of other concerned women's groups.

"It's my main thing now," she says. "Speaking for ERA wherever it's taking me is my full time work." Six months ago, Sonia Johnson told Newsweek magazine that's she is Mormon down to her toes. She says she still is.

But on Dec. 5, 1979, the Church of the Latter Day Saints, in which her family has held membership for five generations, excommunicated her for her outspoken stand on ERA.

The Mormon hierarchy said a church member individually could support ERA but to mount a drive such as "Mormons for ERA" which Sonia Johnson did, could not be tolerated.

SONIA JOHNSON has lost more than her church standing recently. Her husband, father of their four children, 17, 15, 12, and 6 is now somewhere in Oregon.

"He recently divorced me," she says quietly. "He was quite supportive of the ERA and disenchanted with the church, but he had his own problems."

"He wasn't granted tenure at his university and had a mid-life kind of crisis. He found a younger, more beautiful woman."

Regrets? She answers straightforwardly: "I'm not a good regretter." Of the children she says, two are battling adolescence, the 6-year-old is "thinking it over" and the 17-year-old eldest son is trying hard to figure out who he is.

Mrs. Johnson knows who she is. And she doesn't hesitate to say it.

"I'm a radical. I'm angry and I'm determined. We are what we are, and you do what your integrity demands."

Mrs. Johnson lives with her four children in Sterling, Va., southwest of Washington, D.C. For 20 years she taught university English on a

part-time basis. She only has time for her children and the ERA now.

**IN COPENHAGEN** she will be part of the Forum, the non-governmental adjunct meetings taking place concurrently with those sponsored by the United Nations.

She will be part of a panel on equality and religion and will lead a workshop on equality. Fellow panelists will be concerned women from France, Hungary and India.

Institutions in general are on Mrs. Johnson's bad list right now.

It doesn't make any difference whether it's government, religion or the Republican Party she tells you "they're all patriarchal."

"There's no real equality. Women are on the fringes in religion and in all areas. Our society thinks of men as more God-like and as meant to rule."

If you're Sonia Johnson in July 1980, the world couldn't be in worst shape.

"Half the world's population are the life-givers and nurturers and have so much to give and are not allowed to," she says, frustrated. "Women care more about human life than men. They've been involved in life in perpetuating it. The men need to listen to us and deal with hunger and human needs."

"I'M SO ANGRY with the Republican Party," she says. "I was brought up to believe it was the only party, that Democrats were evil. You couldn't catch me voting Republican now. There's an anti-life, hate humans stance."

And of Ronald Reagan their standard bearer, the former English teacher adds: "I wouldn't even trust Reagan to be head of the English Department."

Mrs. Johnson says she was always a "really good Mormon woman."

"I truly believed that someone needed to be home with those children all the time and that someone had to be me. Now I see that they need someone, but it doesn't have to be me all the time."

Part of her current despair is that her own children feel so spirited about the future. "They feel like grownups are going to blow us all up," she says, "And they wonder if there will be jobs."

When she's tired, and she often is, she says all that's happened "just doesn't sink in."

"I just feel as Mormon as I ever was and like what I am, a Virginia housewife."

UNTIL about three years ago, Sonia Johnson knew almost nothing about the ERA. She and her family

lived overseas in Nigeria where her husband had a government contract.

"Becoming a feminist is a whole reorganization of the pattern," she says. "It's like an individual revolution and it was sudden for me, though I must have been gathering data all my life subconsciously."

"Mormonism is so profoundly patriarchal, I was always putting pieces of data into my mental file. Finally, when the church started on the ERA, it all burst out."

Mrs. Johnson recounts that at a

church meeting one night, someone spoke against ERA as she sat and listened.

"Suddenly it all came together. I had like a minor nervous breakdown right in the meeting. I was overwhelmed, actually physically pained," she recalls. "My friends told me later I was shaking my head back and forth and loudly saying 'No, no, no.'"

Up to that time, Sonia Johnson thought all the male supremacy and patriarchy was God's will.



**Lybarger-Kaye**  
Robert and Dorothy Lybarger of Old Salem Road, Plymouth, announce the engagement of their daughter, Deborah Joyce, to John Joseph Kaye of Houston, Texas. His parents are Robert and Connie Kaye of Hauppauge, N.Y. The bride-elect, a student at Western Michigan University in Kalamazoo, will graduate in December. Her fiance graduated in April 1980 from Embry Aeronautical University. He is employed by Texas International Airlines in Houston.

They plan a late summer wedding in First United Methodist Church of Plymouth.

**Turco**  
MANUFACTURING COMPANY

This sturdy, dependable grill is packed with features which include a stainless steel burner, and variable heat cooking.

- 30,000 BTU stainless steel, hemmed, single burner.
- Variable heat control for more precise cooking.
- 288 square inches of cooking surface.
- Heavy duty nickel-chrome plated cooking grid.
- Sturdy, plastic front handle for easy portability.
- Permanent Colorado Lava Rock.
- Includes 20 lb. white tank.

**\$129<sup>95</sup>**

Many other name brand models to choose from: Structo, Charmglow, Weber & Turco  
Choose from in ground or portable

**LIVONIA True Value HARDWARE**  
5 Mile at Farmington  
GA2-1155-937-1611  
DAILY 9-9 • Sat. 9-7 • Sun 10-3

**Underneath it all... Weather-matic, the hidden secret of beautiful landscaping.**

A fully automatic lawn irrigation system keeps landscaping beautiful and healthy for years, saving you TIME and MONEY.

For information on the many equipment options and a cost estimate for installing a Weathermatic system, stop in and we will custom design a system for your landscaping.

DO-IT-YOURSELF or we'll recommend a qualified installer. SAVE 20% on all equipment purchased over \$100.00 before August 1, 1980!

Master Charge & Visa accepted  
"Blue Print for Rain"

**FEDERAL**  
Lawn Sprinkler supply co.  
36010 W. EIGHT MILE RD., SOUTHFIELD, MI 48034

**COUPON**  
GOOD THRU 8/1/80

**20% DISCOUNT ON ALL MATERIAL**  
Purchased Over \$100.00  
(ask about "chemilizer" and fertilize through your sprinkler system)

SUMMER HOURS: Mon.-Fri. 7 am-8 pm Sat. til 5 pm 355-3023

**7 Mile & Farmington shopping center**  
New Home of  
**Highway Ribbery**  
478-8555

**ENERGY.**  
We can't afford to waste it.

**28% OFF All Wallpaper**

No Freight Charge

50c per roll added to all orders less than Full Case (24rls)

We Have the Largest Library Around Over 100,000 Patterns to Choose From

When shopping for price...Don't forget quality  
We take pride in our quality, service and price

**20% OFF All Window Treatments**

Open Daily 10 to 8 Sat. 10 to 5

**Green's**  
CREATIVE HOME CENTER  
107 N. Center (Next to Schrader's)  
Northville 349-7110

**MUFFLERS HEAVY DUTY**

- Custom bending
- Immediate installation
- Free inspection Mufflers Guaranteed for as long as you own your car.

V-8 GM COMPLETE SYSTEMS <b>\$105<sup>95</sup></b> most cars	FORD-MERCURY V-8's <b>\$109<sup>95</sup></b> most cars
GM CATALYTIC-CONVERTER BACK <b>\$74<sup>95</sup></b> most cars	DISCOUNTS ON ALL SYSTEMS FOREIGN CARS, TRUCKS & CAMPER'S

**Schoolcraft Auto Service & Muffler Shop, Inc.**  
36913 Schoolcraft Rd.  
Livonia

591-0679 591-0678

**WHITE ELEPHANT SALE**  
STARTS JULY 17TH

Open Thurs. evening 'til 9:00  
**20% OFF**

- One Hawaiian Print Shirt left over from World War II **\$6<sup>00</sup>**
- Select Bathing Suits worn in the Miss Universe Pageant 1950.  
Bathing Suits & Cover-ups COVER-UP **\$7<sup>00</sup>**  
SUITS **\$12<sup>00</sup>**
- One Raincoat worn by Sam Spade's Assistant **\$11<sup>00</sup>**

**We DON'T want them, TAKE THEM off our hands. Once-In-A-Lifetime Buys**

**Kay's of Plymouth**  
846 W. ANN ARBOR TR. PLYMOUTH 453-7855  
Mon.-Sat. 9:30-5:30  
Thurs. & Fri. til 9

What happens if someone collects my rare coins and silverware?

**Auto-Owners Insurance**

They may not be covered under the homeowners policy you have now. Valuables like furs, silverware and musical instruments deserve, and often require, extra coverage. We'll be happy to analyze your homeowners policy to see if your valuables are adequately protected. And that's not all, we can recommend special Auto-Owners Personal Articles Floater that will keep them covered.

**YOU DON'T HAVE TO SACRIFICE YOUR SKIN FOR YOUR TAN**

IS THE WARM FRIENDLY SUN YOUR SKIN'S NEWEST ENEMY? We have learned many new things about the sun. Skin facts that every person who wants to keep their skin beautiful, healthy and young-looking should know. We know that unprotected skin absorbs the sun's rays—the UVA rays that tan you as well as the UVB rays that burn and prematurely age you. It is important to your skin to screen out the harmful UVB rays. It is important to your tan to let the UVA rays through. Sun Glo allows the tanning rays in—keeps the burning, aging rays out. Sun Glo lets you have a rich tan as well as healthy, beautiful skin.

**Sun Glo Certificate 1 session free per membership**

**SUN GLO TANNING CENTERS**  
38245 W. 10 Mile at Grand River 1/2 Block W. of Holiday Inn Farmington Hills, MI.  
477-0660  
HOURS: Mon.-Fri. 9-9; Sat. 10-6

**DINE OUT TONIGHT**

**FREE INSURANCE ANALYSIS**  
**FRANK HAND AGENCY**  
Complete Insurance Service  
20793 Farmington Farmington  
478-1177

**DINE OUT TONIGHT**

**American** has it all!

**Georgia Pacific Shingles**  
A BUILT-IN SUN ACTIVATED SEALANT BONDS EACH SHINGLE TO THE NEXT. YOU GET MAXIMUM WIND PROTECTION.

**10 COLORS** **22<sup>77</sup>**

**WOLMANIZED LANDSCAPE TIMBERS**

3x5x8	\$3.97
4x4x8	\$4.36
4x6x8	\$6.44
6x6x8	\$9.87
6x8x8	\$12.44

**CREASOTED LANDSCAPE TIMBERS**

4x4x8	3.44 c.c.
4x6x8	4.66 c.c.
6x6x8	7.88 c.c.
6x8x8	8.88 c.c.

MICHIGAN'S MOST UNUSUAL HARDWARE STORE

**American LUMBER & SUPPLY COMPANY**  
Your Complete Home Center  
31245 EIGHT MILE ROAD corner MERRIMAN  
LIVONIA Store Hours: Daily 8-6, Sundays 10-4 **476-6240**

ONE

# Slater-Agardy

Linda Joy Agardy wore her mother's wedding gown for her June 14 marriage to Kenneth Lee Slater in St. Suzanne Church, Detroit. The Rev. John B. Zwiers officiated. The satin and lace gown was worn by the bride's mother 30 years ago and again seven years ago by her sister, Barbara. The bride's parents are Julius and Jean Agardy of Warren Ave., Canton Township. The bridegroom's parents are Delbert and Deloria Slater of Morrison Street, Canton Township.



Barbara Cook of Lansing was maid of honor. Bridesmaids were Victoria Agardy of Plymouth, Debbie Schier-schmidt of Allen Park, Veronica Wince, Anne Wince and Joanne Wince of Garden City. Carolyn Cook was flower girl and Christopher Cook was ringbearer. The bride's attendants wore original design gowns in lavender, peach, blue, yellow, green and pink. They carried off-white fans adorned with roses which matched the bridal bouquet. They wore combs in their hair with matching flowers. The flower girl wore an aqua gown and carried a basket of flowers which matched the colors of all the attendants' flowers.

tario, and Dave Agardy of Canton.

Following a reception for 300 guests, the couple honeymooned in Hawaii.

The bride is a senior at Eastern Michigan University. Her husband earned his bachelor of science degree in business administration from the Lawrence Institute of Technology and is employed by Michigan Consolidated Gas Company. They will live in Westland.

Your carpet needs

## DEEP STEAM CLEANING

TO REMOVE ALL SOIL  
WITH A PRE-SHAMPOO TREATMENT  
PRE-SPOTTING - DEGREASER  
& DEODORIZER.

Call Us

- Spring Special Living Room or Family Room & Hall (Furniture Moved) Reg. \$28<sup>95</sup> **NOW \$23<sup>95</sup>**
- 2nd Additional Room \$12<sup>95</sup>
- 3rd Additional Room \$8<sup>95</sup>

**Gem Carpet 532-8080**  
& Furniture Cleaners  
15542 Delaware • Redford

## TRINITY PARK WEST

1-275 at Six Mile Road in Livonia

Metropolitan Detroit's newest and most accessible supervised residential care facility. For the person who needs that extra bit of assistance and security. Adjacent to Laurel Park Center, western Wayne County's desirable newly developing area.

ONLY A FEW ACCOMMODATIONS LEFT

- FAMILY DINING ROOM SERVICE
- SPECIAL DIFTS
- HOUSEKEEPING
- MEDICATION MONITORING
- RESIDENT AIDES ON DUTY 24 HRS. DAILY
- TRN. AND SERVICES AVAILABLE
- ATTAGIVE INTERIOR & EXTERIOR
- SEMI PRIVATE - PRIVATE
- MARRIED COUPLE ROOMS

**38910 Six Mile Road, Livonia**  
**464-2772**

We Do Area Rugs English Guard Available

## CARPET CLEANING SPECIAL

**\$5<sup>00</sup> Off** Reg. \$35 Now \$30

Any Living Room and Hall plus any additional room \$15

**Includes:**  
Shampoo and Steam Cleaning

**UPHOLSTERY Steam or Dry Clean**

**CALL NOW FOR APPOINTMENT**

### ULTIMATE CARPET CLEANING

Professional Carpet and Upholstery Cleaning  
33223 W. Seven Mile (at Farmington) **476-8380**  
Livonia **476-8381**  
Bonded and insured

## STARTS JULY 28

SUMMER IN-STORE  
WAREHOUSE STYLE  
SKI EQUIPMENT  
SALE

# Bavarian Village

SKI SHOPS

Dr. James Schelberg

## FOOT SPECIALIST

PODIATRIST - FOOT SURGEON

39439 JOY RD.  
E. of I-275 • CANTON  
**455-0770**

All insurances accepted  
Mon.-Sat. and Evening Hours

### clubs in action

**MAMMOTH GARAGE SALE**

Friends of the Leader Dogs will have a giant garage sale from 10 a.m. to 6 p.m. Thursday-Saturday, July 17-19 at 20037 Indian, Redford Township, south of Grand River and east of Inkster Road.

There will be appliances, Avon bottles, baby items, books, children's and adult clothing, furniture, art works, plants, toys, etc. Additional items for sale are welcome. Proceeds will go to the Leader Dog School for the Blind in Rochester. For information call 591-0068.

**STAMP CLUB**

The West Suburban Stamp Club will meet Friday evening in the Plymouth Cultural Center, 525 Farmer Street, Plymouth. Juniors meet at 7:30 p.m., business meeting at 8 and program at 8:30. There will be an APS slide presentation produced by Horace Harrison. It is entitled "Canadian Postal Stationery as Used by the Canadian Pacific Railway." Prospective members are welcome.

**SUMMER COUNSELING PROGRAM FOR ADULTS**

The Women's Resource Center at Schoolcraft College in cooperation with the Counseling Center will sponsor an all-day program for adults re-entering college. Information on academic programs, financial aid, special support services, and a tour of the campus will be provided along with a discussion of career-decision making processes and non-traditional opportunities.

The program will be from 8:30 a.m. to 3:30 p.m. Tuesday, Aug. 12. There will be on-the-spot admission with a \$10 application fee, and a \$1 fee for lunch.

There will be a free evening session from 5:30-9 p.m. Thursday, Aug. 14. This will be a condensed version of the all-day session. Call the WRC at 591-6400, ext. 430 for reservations.

The sessions will be in Rooms B200-210 of the Liberal Arts Building at Schoolcraft College, 18600 Haggerty Road, Livonia.

**ANGER: EXPRESSION OR REPRESSION**

Workshop will be from 10 a.m. to 4 p.m. Thursday, Aug. 7, in Room B200 of the Liberal Arts Building, Schoolcraft College, 18600 Haggerty Road, Livonia. Facilitator will be Mary Beth Dolan. Day will be spent learning how to express anger constructively to avoid building stress. Fee \$20. Bring a bag lunch.

To register call the Women's Resource Center, 591-6400, ext. 430 and ask to be placed on the pre-registration list. Fees are payable on the class date.

**CANTON NEWCOMERS GOLF OUTING**

The Canton Newcomers Club will have a best ball mixed couples golf outing Saturday, July 26 at Fellows Creek Golf Course in Canton Township. Reservations at \$15 per couple can be made by calling Joe Sodbitch, 981-1518. Paid reservations should be in by July 19.

DO YOU KNOW WHAT A **PODIATRIST** DOES?

A Podiatrist is a **SPECIALIST** that attends to the Medical and Surgical management of the feet. This includes:

- Reconstructive Foot Surgery
- Sprains and Fractures
- Painful Ingrown Nails
- Corns - Calluses - Bunions
- Orthopedics

**FAMILY**  
**PODIATRISTS, P.C.**

**591-3500**  
38000 Ann Arbor Trail (at Ann Arbor Rd.) Livonia

## PRICES SLASHED!

HONESTLY

Bathroom

# CERAMIC TILE

## \$199<sup>95</sup>

LABOR & MATERIAL

Choice of many Colors.  
Completely installed in  
Tub area (up to 50 sq. ft.)

**AJAX**  
FLOOR COVERING

**32639 FORD ROAD**  
1/2 BLK. E. OF VENOY  
**427-6620**  
FREE ESTIMATES  
EXPERT INSTALLATION

## Businessmen & Personnel Managers

We have prescreened, interested 16-21 year olds for your Part-time & Full-time positions. Call us with your requirements.

**NO FEE**  
**421-8346**

### Garden City Career Center

## The STORM DOOR

MADE TO LAST A "HOUSETIME"

**35 COLOR COMBINATIONS**  
**19 DIFFERENT MODELS**  
**9 JALOUSIE STYLES**  
INCLUDING STAINLESS STEEL

MADE TO FIT ANY SIZE OPENING  
INCLUDING DOUBLE DOOR SETS  
FACTORY-DIRECT-TO-YOU

**3 DAY DELIVERY ON MOST SIZES**

CALL **534-6080**

OVER 50 STORM DOORS ON DISPLAY  
**2 CONVENIENT LOCATIONS**

## ONE TIME ONLY SUPER SPECIAL

Due to the economic crisis you may be thinking about keeping your car longer and will need

## ZIEBART RUST PROTECTION

Now more than ever

**COUPON SPECIAL**  
**\$35<sup>00</sup> Off**

No other Coupons Accepted During this offer

Good thru July 30, 1980

At These 2 Locations Only

### WESTSIDE RUSTPROOFING

231 Plymouth Road (1 block E. of Lilley) Plymouth • 459-6060

27530 W. Warren (1 1/2 Blks. W. of Inkster) Westland • 425-5216

## PREVIEW SHOWING

Luxury Living on a Private Lake

1 & 2 Bedroom Units  
From **\$345.00**

- Sailing
- Tennis
- Pool & Community Building
- Security Intercom System
- Frost-Free Refrigerator
- Salt-Cleaning Oven
- Dishwasher
- Private Patio or Balcony
- Garport

## Swan Harbour

**NORTHVILLE TOWNSHIP**  
MODELS OPEN 12 to 4  
Except Wed and BY APPOINTMENT  
CALL **348-7677**

## 1/3 OFF

ON ALL STATUARY.  
INCLUDING BIRD BATHS, FOUNTAINS.

**ORTHO FERTILIZER**  
**\$4<sup>99</sup>** 5000 Sq. Ft. Bag

**BLACK DIAMOND BED DIVIDER**  
**\$9<sup>95</sup>** 20 Ft. Lengths

### LUCAS NURSERY AND LANDSCAPE

41680 FORD - Just W. of I-275 • CANTON  
**459-2580**

Summertime is Savings Time at

## NARAGON BUSINESS MACHINES

Your Office Machine Department Store -  
Over 350 Machines in Stock

There's more to selecting a Typewriter than selecting an IBM...See the **NEW SILVER-REED ELECTRONIC** Typewriter with Automatic Correcting and Dual Pitch

Competitively Priced at Only **\$935<sup>00</sup>**

Typing Elements & Ribbons Interchange with IBM

**YES WE SELL RE-CONDITIONED TYPEWRITERS** **RIBBONS INSTALLED WHILE YOU WATCH**

Printing Calculators by Victor---Adler---T.C.A.---& Others from \$89 with up to a 15 MO. GUARANTEE

**ADLER MODEL 10XPD**  
Print and Display  
Reg. \$139<sup>95</sup>  
**NOW \$99<sup>95</sup>**

**14 TO SELL**

**SMITH-CORONA-ADLER-SILVER-REED**  
Portable Typewriters  
Sold at \*Discount Prices -  
Starting at a low **\$139<sup>00</sup>**

\*We still have a few of the **Model 8650** Automatic Correcting Typewriters at **\$209** Reg. \$269 SAVE \$60

No Hi-Pressure...Stop by our showroom for a free demonstration with no obligation.

### NEW & USED COPIERS

From **\$79<sup>00</sup>**

**3M DRY COPIER**  
Reg. \$995... Save \$100... **NOW \$895<sup>00</sup>**

### Electronic Cash Register

Reg.	Sale	Mfgs. Victor B & E T.C.A.
1 Dept. \$495	\$299	
3 Dept. \$695	\$595	
4 Dept. \$825	\$695	

**Features:**  
Automatic Tax Change Computing Large Read Out

Detail Receipt Tape Slip Printer Up to 16 Dept.

## NARAGON BUSINESS MACHINES

26541 Plymouth Rd., Redford 48239

**SALES - SERVICE - RENTALS 937-8811**

### THE WALLPAPER SALE

you've been waiting for!

## fashion WALLCOVERINGS

# 20% OFF!

The newest and most unusual of high-fashion wallcoverings... the ones that are rarely on sale!

**SALE ENDS July 26th**

**KENT'S "everyday extras!"**

- No cutting charges!
- No freight charges!
- Fast service on special orders!

For our customers - free loan of wallpaper books, on over-night basis.

## KENT'S DECORATING CENTERS

OPEN MONDAY & THURSDAY TIL 8 PM.

25655 Joy Road (E. of Beech-Daly) ..... 274-0082  
37250 Five Mile Rd. (at Newburgh) ..... 464-2700

**LIMITED TIME OFFER!**

## \$500 REBATE

DETAILS AT STORE DISPLAY

**HUDSON FAVORITE garden sprayer**

Here's an extraordinary value on a quality sprayer. The Hudson Favorite Sprayer has an over-size pump for fast pump-up. Extra long hose and spray extension with Roto-spray\* nozzle—easy to spray all parts of plants for better results. Instant on-off—no drenching, saves pesticide. Convenient 2-gal. size. Save now!

**OUR LOW PRICE \$37<sup>99</sup>**  
LESS \$5.00 FACTORY REBATE—YOUR NET PRICE ONLY \$32.99

Use With **SPECTRUM SPECTRACIDE**

**105 BUG KILLERS IN ONE CAN.**

From bugs on tomatoes to bugs on roses to bugs any where in your lawn—you only need one bug killer to get them all. Spectracide!

So pick up all-rounder Spectracide today. There's nothing better for getting rid of 105 lawn and garden bugs.

**POOL SUPPLIES**  
**LIQUID CHLORINE - 99¢ or \$3.79 4 gal. case**

- Filter Powder
- Filter Sand
- Conditioners
- Muriatic Acid
- Pool Cleaners

**SAXTONS GARDEN center inc.**

OUR 52nd YEAR 1928-1980

EVERYTHING FOR THE GARDEN BUT THE RAIN

587 W. ANN ARBOR TRAIL PLYMOUTH 483-8280  
Daily 9-6 Fri. 9-8 Sat. 9-5

OLE

# Free Press strikes out

By KEVIN ROSEBOROUGH

Perhaps the most disconsolate group at the convention is the 21-member reporting team from the Detroit Free Press.

Some of the staff, mostly Washington Bureau members, had prepared for the event for a full year. The entire group, along with the rest of the paper's reporters, is now idle amid a flurry of history-making convention activity.

On Saturday members of Teamsters Union Local 372 representing Free Press drivers voted to reject a three-year pact offered them. They also went on strike.

"Most of the editorial staff had no inkling, no indication it would happen," said Free Press reporter Patricia Montemurri. "We thought, like, you're joking. We really couldn't believe it. We thought that they'd be able to work it out."

That was not the case, as the Free Press did not publish a Sunday edition. On Monday, however, a joint edition of the Detroit News and Free Press was

printed by the News, which has agreed to print an abridged edition of the Free Press for the duration of the strike.

Teamsters at the Detroit News were continuing to work under a contract similar to that rejected by the local at the Free Press.

**THE NEWSPAPER** Guild — representing reporters, photographers, copy editors and advertising sales and computer services personnel at the Free Press — is honoring the Teamsters picket line, putting its members out of work.

The skeleton edition of the Free Press being put out in conjunction with the News contains work done by staff reporters prior to the walkout. Much of the material is also produced by reporters employed by the Knight-Ridder chain which owns the Free Press.

Seeing the paper come out without their work makes the situation even more agonizing for the reporters.

"Later on, it sunk in more and more," said Ms. Montemurri. "You could see the despair, the agony going

on. The color was just drained from people's faces."

Still in possession of their media credentials, several reporters and photographers sat gloomily around a table in the Civic Host Committee's media room Monday.

Montemurri said she believed the sudden elimination of the prized convention coverage could constitute an unhealable wound in the minds of many reporters.

"For Free Press reporters, this is one of the biggest stories of the decade. To be deprived of that at the last moment..."

"If they were going to strike the Free Press if the contract wasn't ratified, they could have said that a week ago," she said.

"I never dreamed this could happen," Ms. Montemurri said, shaking her head. "The possibility never occurred to me."

She quoted a saying being circulated by Free Press reporters this way: "Take a Teamster to lunch at the Machus Red Fox."



You can't believe everything you read. A strike by the Teamsters at the Detroit Free Press closed down that paper for a day, making this coin box poster's claim an unlikely possibility.

15 Years Experience  
Don't Procrastinate... Insulate

## JONES Insulation Supplies, Inc.

Licensed & Insured  
Quality Sales & Service  
Residential-Commercial  
BLANKET & BLOWN-IN

Serving Wayne, Oakland & Livingston Counties

OWENS CORNING FIBERGLAS Michigan State License 43881  
John-Manville Quality Building Products

Insulation For The Do-It-Yourselfers  
Instead of Trying to Keep Up With The Jones  
Put The Jones To Work For You!

Call 348-9880  
26111 LANNY'S - NOVI

FREE ESTIMATES  
VISA



## WILD WINGS

You are cordially invited to attend an Exhibition of Paintings by

### RICHARD TIMM

Preview and Meet The Artist  
Sunday, July 20, 1980  
12:00 noon to 5:00 p.m.

### Wild Wings Gallery

975 W. Ann Arbor Trail  
Plymouth, Michigan 48170  
455-3400

Refreshments will be served.

### Hamilton Veterinary HOUSE CALL SERVICE

SERVICES:

- Vaccination programs
- Heartworm prevention
- Parasitic eradication
- Health certification
- Feline Leukemia testing
- Brucellosis testing
- Minor medical attention

Veterinary care for your pet in the security of his own home. Special rates are available for multiple animals to owners and breeders.

William W. Hamilton, DVM, P.C.  
member AVMA, MVMA Call 552-8910  
7 years clinical veterinary experience

WHOLESALE PLANTS **SAVE Savings**

## GIANT TRUCKLOAD SALE

HOUSE AND GARDEN PLANTS

Wholesale Prices  
JULY 17-AUG. 23 9 A.M.-9 P.M. DAILY  
Joy Rd. and Telegraph  
northwest corner

Sponsored by New Life Apostolic Church  
21446 Schoolcraft - Livonia

## MICHIGAN NATIONAL BANK WEST METRO

All Day Saturday Banking  
15 Convenient Locations Serving the Livonia area and Ypsilanti Township

Drive-In Hours: 8 a.m. - 8 p.m. at 4 Locations

421-8200

AN EQUAL OPPORTUNITY LENDER Member FDIC

There's never been a better time to buy an Apple II.

Special

32 K APPLE COMPUTER DISK DRIVE  
ZENITH 13" COLOR MONITOR

Offer Expires 7-19-80 Reg. \$2,175. Reg. Ret. \$2385

### COMPUTER CONNECTION

38437 Grand River Farmington Hills • 477-4470  
Daily 10-8 \* Mon. & Fri. 10-8 \* Closed Sun.

STARTS JULY 28

SUMMER IN-STORE WAREHOUSE STYLE SKI EQUIPMENT SALE

SUMMER DOOR BUSTER PRICES

## Bavarian Village

SKI SHOPS

We specialize in the repair of ANTIQUE WATCHES and CLOCKS

### NORTHVILLE Watch & Clock Shop

132 W. DUNLAP  
116 S. North Main Street  
NORTHVILLE 349-4938

Save during our **Mid-Summer Sale!**

# SEALY SALE

## Save \$60 to \$120 per set!

This Week Only!

Enjoy firm comfort and patented torsion bar construction. Quilted designer print cover.

Twin size ea. pc.	Reg. \$ 99.95	Now \$69.95
Full ea. pc.	Reg. \$139.95	Now \$109.95
Queen ea. pc.	Reg. \$179.95	Now \$149.95
King 3-pc. set	Reg. \$499.95	Now \$379.95

Indulge yourself with Quilted extra thick Sealy foam and a durable Jamask cover. Extra firm construction and extra strong torsion bar foundation.

Twin size ea. pc.	Reg. \$119.95	Now \$89.95
Full ea. pc.	Reg. \$159.95	Now \$129.95
Queen ea. pc.	Reg. \$199.95	Now \$169.95
King 3-pc. set	Reg. \$539.95	Now \$419.95

Try the very best in our Sealy Posturepedic Sleep Center. Posturepedic is designed in cooperation with leading orthopedic surgeons for no morning backache from sleeping on a too soft mattress. Try our complete selection of America's #1 selling mattress.

The Towne and Country Treatment — You'll find no salespeople at Towne and Country Interiors — only IDS or ASID interior designers to help you. Our pay-no-more policy and 3 year construction warranty ensure your satisfaction.

## Towne and Country Interiors

Dearborn 565-3400  
23600 Michigan Ave. east of Telegraph

Bloomfield Hills 642-8822  
4107 Telegraph at Long Lake Rd.

Rochester 652-3500  
1110 S. Rochester Rd. in Winchester Mall

Open daily 10-9 Wed. & Sat. 10-6 Use our convenient charge, Visa or Master Card

# A.R. KRAMER CO. presents

## LEES SUMMER BONUS SALE

### YOU BUY THE CARPET - WE BUY THE...

- 3/8 PRIME URETHANE PADDING
- CUSTOM INSTALLATION
- ALL TAXES

All at no extra cost to you!

From now until July 26 with every purchase of Lees quality carpeting you save four times. You save on the carpet. Then you save on the padding, custom installation and all taxes. It's FREE. Choose from Lees best sellers. For value and quality, it's your best buy in carpet today. And best of all, it's a Lees Hurry, sale and free padding, installation and taxes offer ends Saturday, July 26.

# SAVE up to 35%

ELEGANT PLUSH. A thick, dense dacron plush with lustrous color highlights.	\$12 <sup>00</sup> sq. yd. installed
SAXONY PLUSH. A luxurious saxony plush made with Antron® nylon - today's most durable long-wearing carpet fiber. More fashion colors make it easy to coordinate with your particular decor.	\$13 <sup>50</sup> sq. yd. installed
MULTI-LEVEL. Multi-level pile yarns fashioned in colors to accent any room. Textured effect creates dramatic highlights that will add a new dimension to your decorating scheme.	\$13 <sup>50</sup> sq. yd. installed
TWIST. Crafted from hard twisted nylon yarns that are specially designed for years of outstanding performance. Vibrant colors add to the desirability of this long-wearing best-selling Lees Carpet.	\$13 <sup>50</sup> sq. yd. installed

We will offer professional help in quality, style, performance, and decorating for your assistance. We take great pride in our earned reputation. Ask your neighbor.

### HURRY! Sale Ends July 26

# A.R. KRAMER CO.

KNOWN FOR QUALITY INSTALLATION Since 1925

15986 MIDDLEBELT (Between 5 and 6 Mile)  
LIVONIA 522-5300

HOURS Mon., Wed., Thurs. Fri. 10-9 P.M. Tues. and Sat. 10-6 P.M.



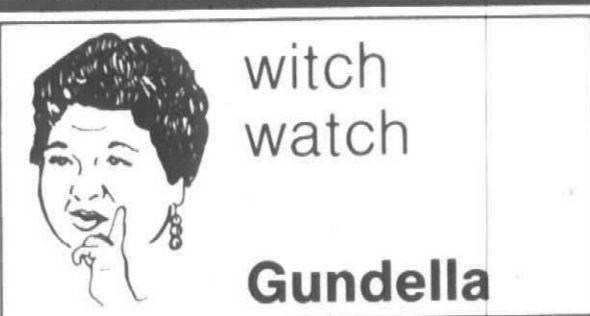

# British also tell ghost stories

A friend of mine recently returned from the British Isles. I asked him if he encountered any of Britain's ghosts while he was visiting there.

He told me that, while he had not seen any evidence of ghosts himself, he had certainly met several people who claimed to have.

He then proceeded to tell me the following tale. In North Yorkshire, there is a 15th century inn in Sandhutton, about eight miles south of Northallerton on A-61.

In this inn, there is a seat next to the piano which is reserved for the ghost of a murderer hanged there in 1702. It is believed that anyone who sits in that seat will be cursed to die within a few short weeks.

The story goes that a man named Thomas Busby married the daughter of Daniel Auty, a counterfeiter. After the marriage, Busby joined Auty in his illegal enterprise, and together they made a great profit.

Eventually, an argument ensued about the sharing of their ill-gotten gains, and, in a fit of temper, Busby killed Auty. Then he spent the rest of the night at the inn, getting drunk, before his arrest.

In the 18th century, it was customary to hang a convicted criminal on the spot where the crime was committed, and then allow the body to stay there and rot as a reminder to others who might be tempted to stray from the path of righteousness.

Busby was hanged, and his body was left to rot on the gallows, right outside the inn.

The legend goes that his ghost wanders about at night, with the hangman's noose still attached to its neck and its head lolling to one side, eyes protruding, and tongue hanging out.

When he is not walking about, he comes and sits on that stool in the pub.

Tom Collins and his wife became the new owners of "Busby Stoop Inn" in 1951. Collins says that since that time, only one man has dared to challenge the curse, and he is no longer living.

It seems that he was a sargeant major in the British army, a hulking big fellow in perfect health.

He entered the inn with a group of friends one night, and refused to believe it when Collins warned him about the ghost and stool. Urged on by his buddies, he sat on the seat — against the protests of the innkeeper and the regular patrons of the inn.

Two weeks later, his friends returned in a very different mood and reported to the barkeep that the sargeant major was dead. He had apparently died of natural causes, although — up until the night he had entered the pub — he had seemed completely healthy.

After telling me this story, my friend confided that he, himself, had chosen a seat on the far side of the room, away from the one by the piano.

## Hearthside's Ethan Allen summer SALE!

These simple, beautiful pieces of fine quality furniture display their heritage in the classic details of period style. Queen Anne legs and graceful curved aprons. Cherished pieces from the past that perfectly answer the modern's need for your home's traditional atmosphere.

Your Choice  
Reg. \$179.50  
\$149.50  
Sale ends Aug. 31

Member of Interior Design Society

VISA • MASTER CHARGE • CONVENIENT TERMS  
90 Day Interest — Free Financing  
Open Mon-Thurs-Fri til 9, Tues-Wed-Sat til 5:30

### the Hearthside

Michigan's Largest Ethan Allen Dealer

LIVONIA 11700 Middlebelt Rd. Phone: 422-8100  
UTICA 1000 E. Main St. Phone: 422-8100  
SOUTHFIELD 11700 Middlebelt Rd. Phone: 422-8100

## Observer & Eccentric Classified Ads Work!

# 20% Off

## LIVE NURSERY STOCK IN YARD

### BLACK DIAMOND EDGING \$9.99

20 Ft. Section .....

Corners & other angles ..... \$2.19

# STAN'S

## Garden Center

38001 ANN ARBOR ROAD • LIVONIA  
464-9418  
HOURS: DAILY 9-7 p.m. SUNDAY 10-5 P.M.

## GARAGE SALE

JULY 18, 19, 20

### J. C. PENNEY

Westland Center only  
Located in the AUTO CENTER

#### CHIP AND DENT FURNITURE SALE

CUSTOM ORDER CANCELLATIONS  
SOME AS-IS CHIPPED, DENTED  
Sofas, Love Seats, Chairs and more  
**30% - 50% OFF**  
Bring Your Truck, Wagon or Car

CHAIR Reg. \$299 **NOW \$149.00**

DEHUMIDIFIERS & AIR CONDITIONERS  
**33 1/3% OFF**

COMMERCIAL LADDERS  
Selected **50% OFF**  
24 Ft., 28 Ft., 32 Ft., & 40 Ft., Flat Step.  
Ex. 40 Ft. Flat Step Ladder  
Reg. \$120<sup>00</sup> **NOW \$60<sup>00</sup>**

## JEROME HOME IMPROVEMENT

State Licensed and Fully Insured

Best Prices in the Industry

# SUMMER SPECIAL

- ALUMINUM SIDING
- ALUMINUM TRIM
- SEAMLESS GUTTERS

FREE ESTIMATES  
PHONE 255-3264, 255-7833  
or 255-3487  
NIGHTS 532-2743

Specialist in Vinyl and Steel Siding

With gas at \$1.35 a gallon it makes sense to vacation at home with a Howmet Skylight Patio Cover.

■ Howmet Patio Covers are finished to look like rich natural wood — but without the upkeep of wood ■ No yearly staining or repainting ■ Skylights let in soft filtered light ■ Available in Rich Walnut, Golden Oak and White Birch Woodgrain. ■ May be enclosed

- Licensed and Insured
- Bank Financing

Call us today for a free estimate.  
• Call Toll Free 1-800-482-6000

**mdi INC**  
AUBURN HEIGHTS, MI

Good Housekeeping Approved

# Only At Sherwin Williams Stores

# Save \$6-\$7 a gallon

on Our Finest Latex Wall Paint and Flat Latex House Paint

Classic 99, Our Finest Flat Latex Wall Paint. reg. \$16.99 a gal. **Your Choice \$9.99 a gal.**

A-100, Our Longest Lasting Flat Latex House Paint. reg. \$16.99 a gal. **\$9.99 a gal.**

**SAVE \$4.00 a gallon**  
A-100<sup>+</sup> Stain and Finish, Exterior Acrylic Flat Latex. reg. \$14.99 a gal. **\$9.99 a gal.**

**SAVE \$6.00 a gallon**  
Classic 99<sup>+</sup> Latex Semi-Gloss Enamel and A-100<sup>+</sup> Gloss Latex House Paint. reg. \$16.99 a gal. **\$10.99 a gal.**

Satisfaction Guaranteed or the money back. See store for details.  
Sale ends Aug. 4

Free Decorating Assistance  
Easy charge convenience with MasterCard or Visa

**Inkster** 27185 Cherry Hill Road 278-8350  
**Plymouth** 863 Penniman Ave. 453-7871  
**Redford** Seven-Grand Shopping Center 533-5230

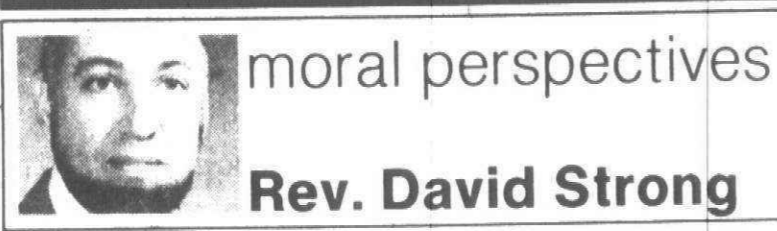

## Denominations should cooperate

I have always felt that the competition and division among churches is a scandal. The early commentary upon Christianity was "see how they love one another." This can hardly be said in the contemporary religious scene.

Churches and denominations ignore each other. They compete and fight. We find few reasons to cooperate, to dialogue and to love one another.

For eight years I was a part of a group of clergy from several denominations who loved, shared and supported each other. We had our misunderstandings and problems, but it was like a family. I no longer have this unique opportunity since I have moved.

Also during part of this same period, the United Methodist congregation, of which I was a part, shared a building, resources and even worship together with a mission Catholic parish. It was a time in which many barriers and prejudices were broken down.

Yet there was also continual opposition to this sharing. We came to know something more of a phrase "see how they love one another," even through the pain and the controversy that accom-

panied some of this involvement. I was enriched by this experience together.

Such dialogue and involvement at a deep level between different religious bodies is unusual today. However, it is possible for local congregations to take the lead in such a process. St. Aidan's Roman Catholic parish in Livonia is carrying out such a dialogue with Lutheran churches throughout this year. Two churches of different denominations have made a covenant together to deepen understanding and ministry in our Detroit area. Yet this is more the exception than the rule.

Recently, I asked a rabbi if he knew of any local congregations who were sharing in an ongoing religious dialogue. He knew of nothing like this happening in the metropolitan area.

The world is getting smaller. We must not wait upon the councils, the conferences, the Vatican or the diocese to discover paths that will lead to understanding, appreciation and mutual love. Every religious body has this goal and this obligation to love one another. For most, it is still expedient to ignore it.

It is my conviction that effective community ac-

tion necessitates religious cooperation and involvement. We cannot speak of love and compassion and service and ignore each other's contribution.

The conference at St. Aidan's church was called "A Time for Healing." There is a feeling that if we cannot heal ourselves we will not be able to heal the world.

The world is inexorably moving closer together. Soon we will encounter the world religions in our own communities. The world will watch to see what we will do: dialogue, appreciate and love, or ignore and confront.

There are those prophets who say that this is the new missionary task, to share and to cooperate in a common religious journey.

A challenge was recently expressed to a struggling group of ecumenically oriented clergy, "If you cannot make it among your own colleagues, how can you make it with others out in the world?" There might be an analogy here for every religious body.

As unpopular and as unproductive, seemingly, as it currently is, our time and our very reason for being, demand religious dialogue and cooperation.

## Workplace democracy is summer school theme

"Extending Workplace Democracy" is the theme of a one-week summer school for union leaders, members and educators to be held Aug. 3-8 at the University of Michigan. Registration deadline is July 25.

The school will bring together unionists and labor educators from all parts of the country to discuss ways to im-

prove employee participation in decision-making at work, according to the U-M-Wayne State University Institute Relations (ILIR), sponsor of the event.

The school will feature general sessions on such issues as participation in the control of new plant and office technology; plant closings and their implications for participation, and com-

parative view of various forms of participation in the U.S. and overseas.

In addition, the school will include four concurrent in-depth workshops on "skills for participatory democracy at work," "teaching about extending workplace democracy," "analysis of current participative scheme," and "implementing 'Quality of Worklife' programs."

A special session will feature Bertil Gardell of the Swedish Center for Working Life and the University of Stockholm, discussing "The Philosophy of a Participatory Work Environment." For further information on the program, tuition, lodging and course credit, contact ILIR, 108 Museums Annex, Ann Arbor 48109; 764-0492.

Paid for by Committee for Wojtowicz

**RE-ELECT Raymond J. WOJTCWICZ**  
(Voy-TOW-veh)  
FULL TIME WAYNE COUNTY  
**TREASURER**

•EXPERIENCE •QUALITY  
•ACCOUNTABILITY •SERVICE  
Endorsed by Labor, Civic and Fraternal Organizations, Business and Industry.

**WOJTCWICZ**  
(Voy-TOW-veh)  
**TREASURER**



### ALUMINUM SIDING

**DO-IT-YOURSELF Summer Specials**

SOFFIT SECONDS-BROWN Solid .....	\$28.95 Sq.
Lanced .....	\$24.95 Sq.

Siding First Quality  
8" white.....\$46.95 Sq.  
4" white.....\$47.95 Sq.

Siding - Vinyl  
8" white.....\$49.00 Sq.  
4" white.....\$50.00 Sq.  
Coil Stock 24" x 50'.....\$41.95  
Gutter Seconds  
5" K Color.....25¢ Ft.  
Downspouts  
Seconds.....\$2.95 Ea.  
Gutter First Quality  
White/10, 20, 25, 30, 38...52"  
Foam Insulation.....Ft.  
8" drop in.....\$7.75 Sq.  
1/2" w/foil (4x4).....\$3.00 Ea.  
1/2" Plain (4x8).....\$2.95 Ea.

7" Aluminum corner columns  
White or Black...\$20.00  
**Special Trim Bent to Order or Rent-A-Brake**

ALL ITEMS EXPIRE 7-19-80

### VIKING ALUMINUM Corp.

30175 FORD ROAD, GARDEN CITY  
421-5743 (between Middlebelt and Merriman) copyright 1980

OPEN: DAILY 8-5, SAT. 8-1

**SAVE MONEY ON YOUR HEATING BILLS!** **CUT HEAT LOSS**

### DO-IT-YOURSELF

**Warehouse Special Only \$29.95 Sq.**

Horizontal Seconds Colored Siding Quantities Limited While Supplies Last

**Roofing Shingles Self-seal Special \$22.95 Sq.**

Cash & Carry White & Colors

### STORM DOORS

COLONIAL CROSSBUCK (1) Pre-hung.....\$49.95  
**STORM DOOR ALUMINUM** (not illustrated) PRE-HUNG.....\$47.95  
**STORM WINDOWS** 3 Track.....\$29.85

Free Nailing Apron with purchase  
CUSTOM MADE SHUTTERS Your Choice of 20 colors

### SWIMMING POOL CHEMICAL SALE!

From Michigan's Largest Swimming Pool Dealer  
"LAST FOUR TIMES LONGER" as Lloyd Bridges says on T.V.

Good thru 7-23

20 LB. GRANULAR CHLORINE \$48.88 WITH VISCOUNT COUPON

25 LB. CHLORINE TABLETS \$68.88 WITH VISCOUNT COUPON

25 LB. TABLET CHLORINE \$68.88 WITH VISCOUNT COUPON

GAL. ALGAEICIDE \$48.88 WITH VISCOUNT COUPON

ALGAEICIDE Concentrated Gallon

Good thru 7-23

GAL. LIQUID CHLORINE 98¢ WITH VISCOUNT COUPON

LIQUID CHLORINE-No Limit

Good thru 7-23

SUN 16 LB. CHLORINE TABLETS \$45.88 WITH VISCOUNT COUPON

16 LBS. TABLET CHLORINE

Good thru 7-23

SUN HAND SKIMMER \$38.88 WITH VISCOUNT COUPON

DELUX HAND SKIMMER

Good thru 7-23

SUN POOL LADDER \$68.88 WITH VISCOUNT COUPON

NEVER RUST POOL LADDER

**Krandall's invites you...**

to bring your diamonds and jewelry in today and convert them into

**Immediate Cash!**

discussions will be conducted in private offices with consideration for your confidence and respect for your dignity. Evaluations for purchase without obligation.

**Sidney Krandall & Sons**  
755 W. Big Beaver Rd. Troy, Michigan  
(16 Mile at I-75) • Phone: 313-362-4500

**PVC QUEEN CHAISE LOUNGE SAVE 20%**



\$140  
Reg. \$175  
Sale thru 8/1/80

Available in assorted colors Guaranteed not to fade, water repellent, no painting.

**Sittin' Pretty**  
Indoor & Outdoor Furnishings  
UNUSUAL GIFT ITEMS 20% DISCOUNT  
Lathrup Landing, 11 Mile & Evergreen  
552-8850 M,T,W,F,S, 10-5:30 Thurs. til 8

### Woodstoves

•BLACK BART •TIMBERLINE  
•OIL HICKORY and others

• Financing Service  
• Free Home Estimates  
• Permanent Address  
• Insulated Pipe

**ENERGY STORE**  
16709 Middlebelt (Between 5 & 6 Mile)  
Livonia 427-3300

### ENJOY LIFE SWIM IN A VISCOUNT POOL

We will meet any advertised price on any swimming pool chemicals — PLUS — WE GIVE YOU FULL SERVICE!!!

**Viscount Pools**  
The Pool People

ANN ARBOR 995-7665  
2635 Saline Rd. at I-94

TAYLOR 287-3100  
23640 Eureka East of Telegraph

MT. CLEMENS 792-4920  
30534 Groesbeck South of 16 Mile

PORT HURON 982-5225  
3333 Electric Ave.

LIVONIA 261-8580  
34722 Plymouth Rd. East of Wayne Rd.

**Rite Carpet**

SAVE 30%-60% Famous Maker REMNANTS & ROLL ENDS

**BRIGHTON**  
Brighton Mall 227-1314  
Mon., Thurs., Fri. 9-9 Tues., Wed., Sat. 9-6

**LIVONIA**  
7 Mile and Middlebelt Across from Livonia Mall 476-8360  
Mon., Thurs., Fri. 9-9 Tues., Wed., Sat. 9-6

The less he spoke the more he heard. Why can't we all be like that bird?

E. H. Richards

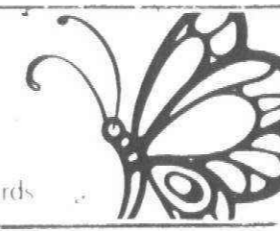

**Special Sale**  
Now thru July 23

**SANSABELT SLACKS**

Values to \$50  
**\$27.50**

**ALLIE BROS**  
OF LIVONIA  
20331 Middlebelt - Livonia (2 blocks So. of 6 Mile) 477-4434  
Mon.-Fri. 9-5:30 Sat. 9-Noon



### ROOT'N TOOT'N BURGER KING CAR SWEEPSTAKES

**Win a real race car 7 feet long!**

REAL ENGINE, BRAKES, FIBER GLASS BODY!

LIKE THE KING & HIS ROYAL COURT DRIVE ON TV



### KIDS! ENTER OUR BURGER KING CAR SWEEPSTAKES!

**OFFICIAL ENTRY BLANK**

**Official Rules:** Fill out official entry blank. Misaddressed or illegible entries and facsimiles or copies of signatures void. No purchase necessary to win. All entries must be deposited at the information Booth, Twelve Oaks Mall or Burger King, Twelve Oaks Mall only. Entries for the drawing July 30th, 3:00 p.m. must be received by July 30th. No limit on number of entries per person. Winner need not be present at drawing. Winner will be notified by mail. Prize won by minor will be awarded to parent or guardian's name. If required by law, parent or guardian must sign injury release form for a minor that wins the mini-car. Entrants agree that Burger King Corporation, its agents and employees of News Associates Inc., The Taubman Co. Inc. Twelve Oaks Mall Promotion Committee and Hudson's, Sears, Penney's, and Lord & Taylor shall not be liable for injuries or losses of any kind occasioned or contracted with acceptance or use of prize or part thereof. Name of the winner will be posted at the participating Burger King restaurant following the drawing. Employees and their immediate families of Burger King Corporation, its franchisees and its agencies are not eligible. Winner is responsible for all taxes. Winner consents to the use of winner's name, address, likeness and prize information. No alternate prize or cash will be awarded.

Win a real, scaled, down mini race car complete with engine, fiber glass body, brakes! An off-road vehicle.

**Drawing Held At Burger King® Restaurant**

Name \_\_\_\_\_  
Address \_\_\_\_\_  
City \_\_\_\_\_ State \_\_\_\_\_ Zip \_\_\_\_\_  
Age \_\_\_\_\_ Phone No \_\_\_\_\_  
Signature \_\_\_\_\_  
Enter Before Drawing On \_\_\_\_\_  
©1980 Burger King Corporation. All rights reserved. Printed in U.S.A.  
K 2838

**BURGER KING CAPTURES THE WEST!**

See me in person  
July 29, 30, & 31st

MAGIC SHOWS AT 1:30, 3:30 & 6:00 EACH DAY!

COLOR 'EM PARDNER! BURGER KING COLORING CONTEST

PRIZES AT EVERY SHOW!

ENTRY BLANKS AND ENTRY BOX AT INFORMATION BOOTH



### "WESTERN DAZE" SUMMER SAUINGS AND FUN!

Located on Novi Road, North of I-96  
10:00 a.m. - 9 p.m. Monday-Saturday  
Sunday 12:00-5:00 p.m.

**twelve oaks mall**





Pat Bordman

## Enlarge child' world



Plant a few seeds and a mini-tree will begin to unfold. (Photo by Pat Bordman)

Ideas. Concepts. Thoughts.

The only way we know what our children are thinking is through their tendency to think out loud. Called liberated convictions, this thinking out loud gives us clues to their reasoning processes.

A child carefully constructs ideas in an effort to order and organize the surrounding events, sights and sounds. Most of the world seems quite mysterious to a child's unpracticed eyes.

How can a light bulb turn into a daffodil in springtime? Is thunder God moaning from a stubbed thumb? Why is fire always angry? When will that tree answer me?

These ideas of a child's world can be at once funny, profound, and wise, but most often they are confused. Try as we might, we usually cannot dissuade a child from these faulty notions.

Children hold stubbornly to their ideas. They resist suggestion. They rebuff correction.

The only way to effectively alter these fanciful concepts is to enlarge the child's scope of the world. This would provide enough experiences so the experiences themselves begin to challenge the ideas, rather than the

challenge coming from the parents.

ONE OF THE real confusions in the young child's world is figuring out where things come from.

Fruits and vegetables would appear to spring full-grown from the grocer's shelves. Potatoes come from boxes. So many things that a child encounters come boxed, completed, already finished.

A simple walk in the neighborhood may be one way of gently helping our little ones shape their ideas in a more realistic fashion. A friend's garden can reveal much about the nature of nature.

The variety of greenery, birds, and insects will broaden the child's information background. Trees do not start out full-grown or from a landscaper's truck.

Perhaps you'll be lucky enough to come across a maple tree laden with seeds. Allow your child to collect a handful and take them home.

In a pot of dirt, have your child gingerly "plant" the seeds. Talk about how nature does the planting, by showing your child how the seeds float to the ground. As the seed swirls to the ground, the heaviest part gets stuck in the dirt.

# PLYMOUTH NURSERY

COMPLETE GARDEN CENTER  
QUALITY NURSERY STOCK  
DESIGNING AND PLANTING

## FRUITING BUSHES

**NOW IN FRUIT**  
Why wait until next year to pick Fruit — Our plants are in fruit RIGHT NOW! All potted plants.

<b>Eldorado Blackberry</b> .....	\$3 <sup>00</sup>
Profuse Delicious Fruit	
<b>Elderberry</b> .....	\$6 <sup>95</sup>
Rapid Growing	
<b>Concord Grapes</b> .....	\$3 <sup>00</sup>
Dark Blue Grapes	
<b>Niagra Grapes</b> .....	\$3 <sup>00</sup>
High Quality White Grapes	
<b>Fredonia Grape</b> .....	\$3 <sup>00</sup>
Top Blue Grape in its Class	
<b>Red Lake Currant</b> .....	\$3 <sup>00</sup> & \$3 <sup>95</sup>
Medium to Large Berries in Clusters	
<b>Gooseberry</b> .....	\$5 <sup>95</sup>
Large Gold Berries	
<b>Latham Red Raspberry</b> .....	\$4 <sup>50</sup>
Hardest Red Variety	
<b>Weymouth Blueberry</b> .....	\$4 <sup>95</sup>
Highbush Blueberry	
<b>Hazelnut</b> .....	\$6 <sup>95</sup>
Bushy Upright Plant	

**WE STILL HAVE A LARGE SELECTION OF FRUIT TREES**

---

**9900 ANN ARBOR - PLYMOUTH RD.**  
7 MILES EAST OF U.S. 23, 5 MILES WEST OF SHELDON

OPEN DAILY 9 - 6  
SUNDAY 10 - 6      ph. 453-5500

### Motley to star

Larry Wright and Motley the Cat will be guests of the Anthony Wayne Cat Fanciers at its fifth annual Championship Cat Show July 19-20 at the Allen Park Civic Arena, 15800 White, Allen Park.

Wright, illustrator of "Wright Angles" cartoon strip featured in The Detroit News, will be on hand with his "real life" Motley to sign autographs and award the coveted Morris trophy to this year's Best Household Pet in Show.

# KOSINS 1/2 OFF SALE

**OUR GREATEST AFTER-INVENTORY SALE IN 55 YEARS**

Because it has been our tradition never to carry over merchandise from season to season and because of our rapid growth this past year, Kosins is now offering 1/2 off the very finest in mens' clothing from the world's leading designers. This is one sale that will amaze even the most discriminating gentlemen. Hurry for best selection!

### SUITS

- Famous names like Lanvin, Adolfo Givency, Oleg Cassini, Hardy Aimes, Giorgio Sant' Angelo, Le Baron, Louis Roth, & Lou Myles
- Regular \$195<sup>00</sup> ..... Now **\$ 97.50**
  - Regular \$225<sup>00</sup> ..... Now **\$112.50**
  - Regular \$285<sup>00</sup> ..... Now **\$142.50**
  - Regular \$325<sup>00</sup> ..... Now **\$162.50**
  - Regular \$375<sup>00</sup> ..... Now **\$187.50**
  - Regular \$450<sup>00</sup> ..... Now **\$225.00**

### SPORTCOATS

- Famous names like Givency, Adolfo, Lanvin, Oleg Cassini, Hardy Aimes, & Le Baron
- Regular \$175<sup>00</sup> ..... Now **\$ 87.50**
  - Regular \$195<sup>00</sup> ..... Now **\$ 97.50**
  - Regular \$225<sup>00</sup> ..... Now **\$112.50**
  - Regular \$250<sup>00</sup> ..... Now **\$125.00**
  - Regular \$275<sup>00</sup> ..... Now **\$137.50**

### SLACKS

- All Different Styles & Fabrics
- Regular \$55<sup>00</sup> ..... Now **\$27.50**
  - Regular \$65<sup>00</sup> ..... Now **\$32.50**
  - Regular \$75<sup>00</sup> ..... Now **\$37.50**
  - Regular \$95<sup>00</sup> ..... Now **\$47.50**
  - Regular \$115<sup>00</sup> ..... Now **\$57.50**

### SHOES

- Names like Bally, French Shiner, Pierre Cardin, YSL, San Remo, Adolfo, Hand-Sewn, including Boots & Shoes. Lathrup Village Store only
- Regular \$75<sup>00</sup> ..... Now **\$37.50**
  - Regular \$90<sup>00</sup> ..... Now **\$45.00**
  - Regular \$98<sup>00</sup> ..... Now **\$49.00**
  - Regular \$120<sup>00</sup> ..... Now **\$60.00**
  - Regular \$135<sup>00</sup> ..... Now **\$67.50**
  - Regular \$145<sup>00</sup> ..... Now **\$72.50**

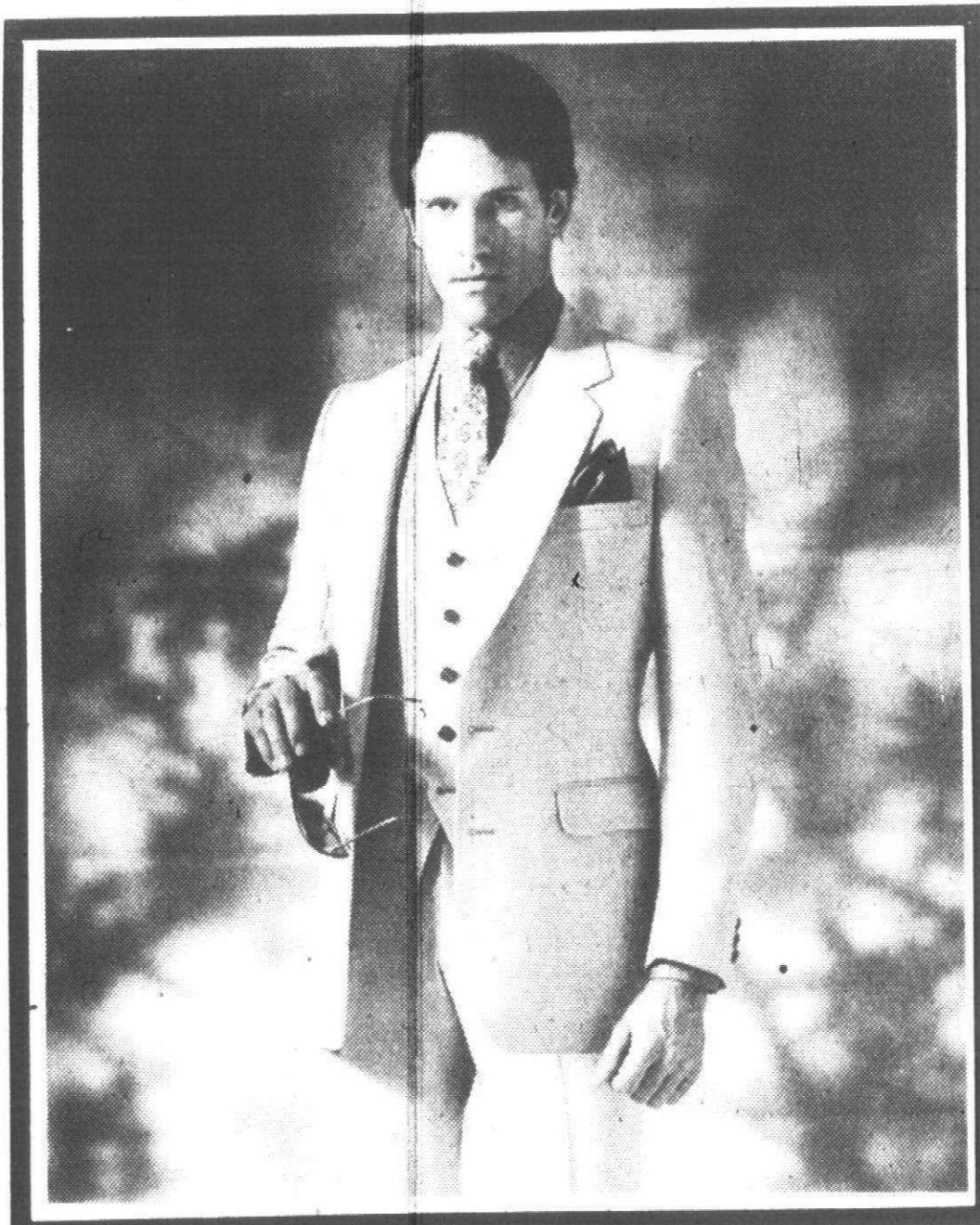

### SPORTSHIRTS

- Names like Bill Blass, Oleg Cassini, Damon, Geoffrey Beene, Geno, Linea Italiano, Givency, & Serica
- Regular \$30<sup>00</sup> ..... Now **\$15.00**
  - Regular \$37<sup>00</sup> ..... Now **\$18.25**
  - Regular \$30<sup>00</sup> ..... Now **\$15.00**
  - Regular \$37<sup>00</sup> ..... Now **\$18.75**
  - Regular \$42<sup>00</sup> ..... Now **\$21.25**
  - Regular \$45<sup>00</sup> ..... Now **\$22.50**
  - Regular \$55<sup>00</sup> ..... Now **\$27.50**

Not all merchandise available at all stores.

# Kosins

**DOWNTOWN** • 1430 Griswold (Bet. Grand River & Clifford) • Mon., Wed., & Fri. 'til 8, Tues. & Thurs. 'til 6, Sat. 'til 7 • Phone 961-8751

**KOSINS BIG & TALL** • Lathrup Village (Southfield at 11 Mile) • Mon. - Fri. 10-9, Sat. 9-6, OPEN SUNDAY 12-5  
Phone 569-6930

**UPTOWN** • Lathrup Village, Southfield Rd. at 11<sup>1/2</sup> Mile, Mon. - Fri. 10-9, Sat. 9-6, OPEN SUNDAY 12-5  
Phone 559-3900

Major Credit Cards Honored • FREE Parking • Phone & Mail Orders Welcome

**Garage Sale**

Read about it!

Classified Ads

644-1070  
Oakland County 591-0900  
Wayne County 852-2222  
Rochester/Avon

**Did you know we can find a breast cancer as small as the head of a pin?**

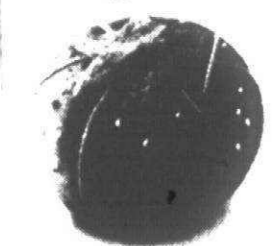

Such a tiny cancer can almost always be cured. A cancer of this size can best be found by mammography — a technique of low dose breast x-rays. Using far less radiation than ever before, mammography can detect a cancer long before a lump can be felt. While the cancer is still highly curable.

Not every woman needs mammography. But for those women over 50 or with special reasons to be concerned, like those with symptoms or a strong family history of breast cancer, mammography can find a tiny cancer before it has spread. Ask your doctor about mammography.

**American Cancer Society**



# KROGER COST CUTTERS

Another great way to cut your costs at Kroger!

PRICES & ITEMS GOOD MON., JULY 14 THRU SUN., JULY 20, 1980.

### ADVERTISED ITEM POLICY

Each of these advertised items is required to be readily available for sale in each Kroger store, except as specifically noted in this ad. If we run out of an advertised item, we will offer you your choice of a comparable item, when available, reflecting the same savings or a raincheck which will entitle you to purchase the advertised item at the advertised price within 30 days.

**Kroger .5% Milkfat LOWFAT MILK**  
**\$1.29**  
 Plastic Gal Jug

Center Cut LOIN PORK CHOPS \$1.58 Lb

ADDITIONAL QUANTITIES \$1.59 Gal Jug NO LIMIT

Limit 1 With Coupon Available In Store And Additional \$5 Purchase

**Center Cut RIB PORK CHOPS**  
**\$1.48**  
 Lb

**Holly Farms**  
 Grade A **MIXED FRYER PARTS**  
**49¢**  
 Lb

USDA A GRADE

**FAYGO POP**  
**8 \$1.39**  
 1/2-Liter Btls Plus Deposit

Assorted Regular Or Diet Flavors

**U.S. Gov't Graded Choice SIRLOIN STEAK**  
**\$2.77**  
 Lb

**Jamestown PORK SAUSAGE**  
**59¢**  
 1-Lb Roll

**Regular Or Thick OSCAR MAYER SLICED BACON**  
**\$1.29**  
 1-Lb Pkg

**Grade "A" 25-Oz To 32-Oz Avg CORNISH GAME HENS**  
**89¢**  
 Lb

**COUNTRY CLUB ICE CREAM**  
**\$1.09**  
 1/2-Gal Ctn

Assorted Flavors

**Red, Ripe WHOLE WATERMELON**  
**\$1.98**  
 Each

Large 18-22 Lb Avg  
 Limit 3 With Coupon Available In Store

**Luscious NORTHWESTERN CHERRIES**  
**79¢**  
 Lb

First Of The Season Sunnyslope Peaches Lb 69¢

**Kroger GRADE A LARGE EGGS**  
**59¢**  
 Doz Ctn

Grade AA MARKET BASKET LARGE EGGS 63¢ Doz Ctn

**SOOPER COST CUTTERS**

Save Up To **40%**  
 ON MANY SOOPER COST CUTTERS COMPARED TO OTHER BRANDS OF THE SAME ITEM SOLD AT KROGER!

**Picnic Special Blue Bird PAPER PLATES**  
**79¢**  
 100-Ct Pkg

**Great Lakes CHARCOAL BRIQUETS**  
**\$2.59**  
 20-Lb Bag

**Makes 8-Qts Assorted Avondale POWDERED DRINK MIX**  
**99¢**  
 1-Lb 8-Oz Can

**Thick AVONDALE CATSUP**  
**69¢**  
 Qt Btl



### Delicatessen Specialties

AVAILABLE ONLY IN STORES FEATURING A DELI

- Lean Cooked Ham \$2.79 Lb
- Chunked Or Sliced Delicious Domestic Swiss Cheese \$2.98 Lb
- In A Re-Usable Container Mustard Or American Potato Salad \$1.99 3-Lb Tub

OVER A MILLION MICHIGAN SHOPPERS... can't be wrong!

Thursday, July 17, 1980

(C)1C

Plymouth golfer earns shot at \$10,000

# Chamberlain putts way into national finals

The Southeastern Michigan Regional portion of the National Open Putting Championships had a decidedly Plymouth bent last weekend at Whispering Willows Golf Course.

Jerry Thomas, 21, currently a Livonia resident but a graduate of Plymouth Salem High School, placed second overall in the 62-man field.

William Chamberlain, who resides in Plymouth, won a separate playoff to qualify as the second non-amateur for the national finals from the Livonia site.

Thomas' score of 33 putts over the 18-hole layout on the practice green was matched by Craig McClellan, a Woodhaven resident, who was low-scoring non-amateur.

McClellan won the first-place trophy on the second extra hole and earned an expense-paid trip to the national tournament Dec. 5-6 at the Tropicana in Las Vegas.

Thomas indicated that he will probably make the trip to Vegas at his own expense to maintain his amateur standing.

Chamberlain was involved in a six-man playoff and came away the second non-amateur finalist after four extra holes. He posted a score of 35 during the regulation 18 holes.

Thomas, who, coincidentally, won the Championship Flight of the Observer & Eccentric Golf Tournament last year at Whispering Willows, does not

consider himself to be an especially outstanding putter.

"Believe me, I'm not a putter. I proved it the next day when I played out at Salem Hills, hit 14 greens and got only one birdie," said Thomas, who works at Salem Hills.

Consistency rather than flashes of brilliance paid off for Thomas. During 36 holes of qualifying rounds at Salem Hills, the 18 holes at the regional final and two playoff holes, Thomas one-putted only seven times and never three-putted.

"The only reason I got into the tournament is that any time you can get in and play under some pressure, it's going to help out in the long run," said Thomas.

**CHAMBERLAIN**, who works in the quality control division at Ford Motor Co., also said that he was stunned to win a trip to the finals.

"I didn't really have any expectations because all these guys were tops in their field. I was surprised and pleased because so many were darned good," said Chamberlain.

"I'm going to put in a great deal of time from now on practicing for Las Vegas. I've never been out there," he said.

Thomas and Chamberlain completed their regular rounds Saturday morning before the rains fell. Both playoffs were held later in the afternoon.

Chamberlain said that he did better on the softer, slower putting surface after the rain. Thomas said that he noticed the greens weren't as quick later in the day, but he didn't think it affected his game one way or another.

Only nine of the 62 regional finalists broke par — which was 36 — for the 18 holes. Holes ranged in length from 10 to 50 feet.

The Whispering Willows Regional hosted qualifiers from Salem Hills, River Raisin in Monroe and Whispering Willows.

AREA SCORES AT REGIONAL

- 33 — Jerry Thomas (Livonia).
- 35 — William Chamberlain (Plymouth); Aaron Kales (West Bloomfield).
- 36 — Pat Shannon (Garden City).

(Continued on Page 5C)

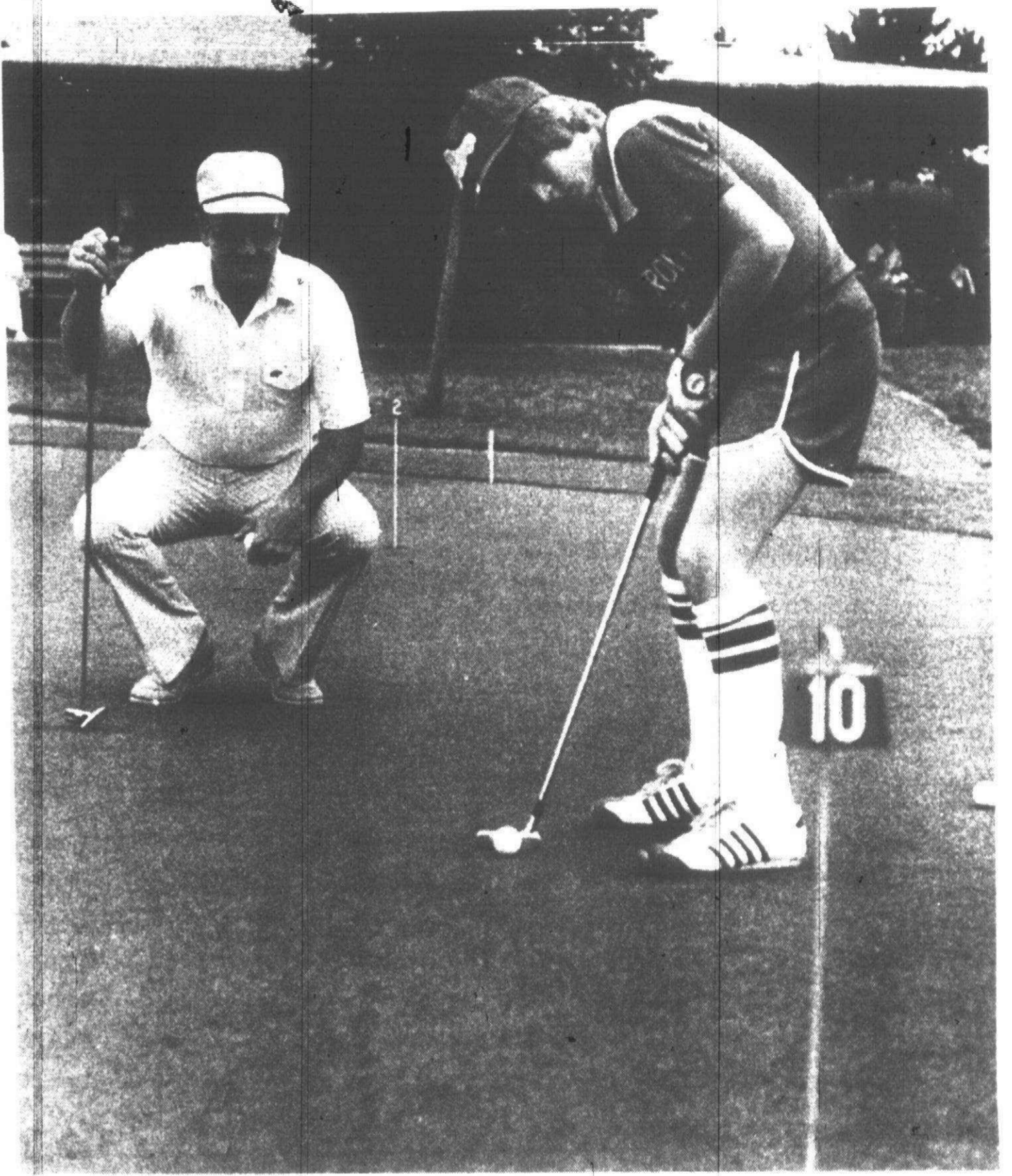

William Chamberlain (left) of Plymouth watches of the National Open Putting Tournament at Whispering Willows. (Staff photo by Art Emanuele)



John Rigelsky of Plymouth shows his form Saturday at the National Open Putting regional tournament. (Staff photo by Art Emanuele)

Defending champs fall in title game

## Bill's Market wins softball crown

A potent offense and solid pitching carried Bill's Market to the Plymouth Modified Softball Tournament title over the weekend at Central Middle School.

Bill's outlasted 15 other teams in securing its first crown. The difference was Bill's two-of-three wins against rival Morrell's Builders.

In the championship final, Bill's jumped out to a 2-0 first-inning lead against Morrell's and were never headed in an 8-5 triumph late Sunday night.

Pitcher Jerry Staszal held off Morrell's enough to pick up the win. Team-mate Bob Ridling, the tourney MVP with an .800 batting average over six games, provided the offensive punch by going 2-for-4.

Bill's, currently leading Morrell's by

one-half game in the Plymouth Recreation Modified League (Tuesday-Thursday), also had three other players hit over .700 — Bobby See, Ron Ray and Bobby Duman.

"It's hard to single anyone out," said Bill's manager Ron Okerstrom. "Everyone contributed. Casey (Ken) and Staszal did a good job pitching.

"Duman and Ridling's hitting were the keys. It was a very good team effort."

Morrell's forced a final game with a 7-6 victory over Bill's as Mark Crawford delivered a game-winning two-run single in the bottom of the seventh with two out.

IN A SEMIFINAL meeting between the two teams, Bill's whipped Morrell's

10-5 as Ridling went 3-for-4. See added two hits.

Bill's scored five times in the fifth inning to break the first showdown wide open. Staszal earned the victory.

In the first round, Bill's routed Calvelli's, 16-0, and then nipped St. Gerald's in a thriller, 7-6.

Duman smacked a clutch three-run single with two out in the bottom of the seventh to keep Bill's in the winner's bracket. St. Gerald's seemingly had things in control, leading 5-0 in the fifth, but Bill's rallied to take away the upset bid.

Duman, a centerfielder, made a diving catch to thwart a St. Gerald's rally. Ray belted an inside-the-park homer.

In the third round, Bill's tripped Mason's Lounge, the eventual third-place finishers, 16-7.

Morrell's opened the tourney with three straight victories against All Phase, the Raiders and Sports Illustrated.

"It was a very good tournament," said Chuck Skeen, Plymouth Recreation director. "Because of the rain, we had to play in the wee hours of the morning."

The rains on Saturday kept groundskeepers Dave Wheeler, Tom Willette and Bill Pierce busy.

Morrell's and Bill's will probably meet again July 25-27 in the ASA Regional Tournament at Central. Bill's holds a 4-3 edge in the series.

Morrell's, the defending champs, also hit the ball with authority despite the runners-up finish. Steve Robb, an infielder, collected 10 hits in his first 12 trips to the plate.

## Canton Caesars outlasts Elks, 9-8

By BRAD EMONS

It was time to get into foxholes and wear helmets.

Canton High School's baseball field resembled a combat zone Tuesday night as Canton Little Caesars outslugged the Salem Elks, 9-8, in a Redford-Adray Connie Mack League baseball game.

The victory gives Canton a league-leading 11-2 mark. The Elks slipped to 7-6.

"I was kind of surprised the score was so high," said Caesars coach John Gravlín. "But we hit the ball hard."

Salem coach Ben Wilcox, however, said the conditions were right for an offensive assault.

"With the heavy air I knew it would be a hitters' game," he said.

Temperatures hovered near 90 degrees at game time. The high humidity made it seem even warmer.

Trailing 1-0 in the first inning, Canton exploded for three runs in the bottom of the first. Catcher Frank McMurray delivered the key blow with a bases-loaded double which hit near the base of the center field fence.

Hits by Hsiao Peng and Dave Slavín, along with couple of Canton miscues, knotted the score at 3-all in the top of the second.

In the top of the third with the bases loaded, Peng came through with a triple to right field off Canton starter Al Lipinski, giving Salem a 6-3 advantage.

It didn't last long, though, as Canton came back with four runs. Keith Stone led off with a single and Jeff Stemberger's followed with a double. Dave Meador's double drove both runners home to make it 6-5.

Lipinski then marched up and crushed a homer over the center field fence to lift Canton to a 7-6 advantage.

Two Salem errors in the bottom of the fourth upped Caesars' lead to 9-7.

The Elks got single runs in the fourth and fifth innings, but were stymied by Canton reliever Dan Funkhouser, who picked two runners off in the seventh.

He hurled two scoreless innings to shut down the Salem attack, preserving the win for Lipinski. Salem's Jim Jimmerson, who allowed nine hits, suffered the loss.

"We had moments of grandeur," said Wilcox, "and then we'd kick ourselves in the fanny."

In the sixth, Funkhouser was saved when Salem's Mitch Wilcox was thrown out at third base trying to stretch a double.

He ended another Salem threat in the seventh with his slick pick-off move.

"Danny's worked on it a lot," said Gravlín. "He has that long leg kick that's kind of deceptive."

mStemberger paced the Canton offense with three hits. Lipinski added two.

Wilcox, Jimmerson, Greg Etienne and Peng each collected two hits for Salem.

CAESARS-SOUTHFIELD

Lefty pitcher Dan Funkhouser tossed a three-hitter, struck out four and picked two runners off base to lift Canton Caesars to a 9-0 Redford-Adray Connie Mack League baseball win Saturday over Southfield.

The victory raises Canton's overall mark to 10-2.

"Dan has quite a move to first base," said Canton interim coach John Gravlín. "He was real tentative in his last

start. He came right at them Saturday."

First-place Caesars totaled 10 hits, left five on base and committed one error.

Canton broke a scoreless deadlock in the fourth inning with three runs.

Catcher Billy Hanis came through with a two-run single in the inning.

Caesars added four runs in the fifth.

Shortstop Al Lipinski walked and went to second on Frank McMurray's single. Don Dreher and Hanis followed with walks, forcing home Canton's fourth run.

Steve Schumacher then slapped a double, one of his three hits, scoring McMurray and Dreher. Keith Stone singled home Hanis with the fourth Canton run of the inning.

In the sixth, Dave Meador led off with a double and scored on Lipinski's triple. A ground out by McMurray, scoring the Canton shortstop, ended the scoring.

Canton was well on its way to winning its 11th league game of the season before rain halted play in the nightcap after one inning and Caesars leading, 5-0.

The Plymouth Salem Elks' double-header was also washed out Saturday against Bishop Borgess. Salem and Borgess were tied 5-all after four innings of play.

### Lustra Wall Porch Enclosures

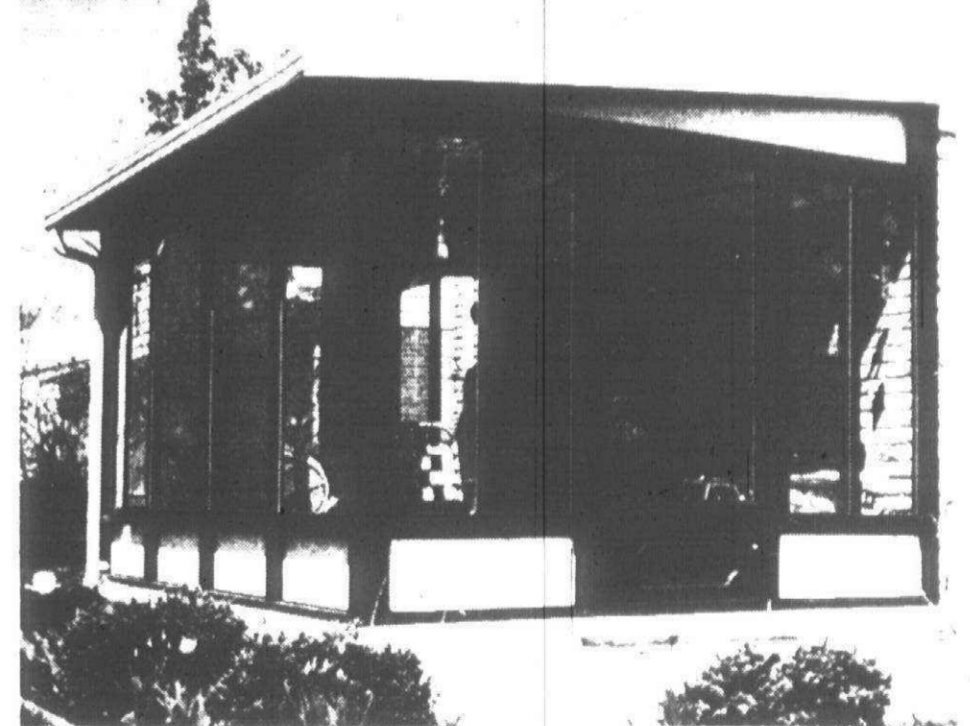

SAVE MONEY!!!  
DIRECT FACTORY PRICES  
NOW AVAILABLE TO YOU

The very best in Quality  
Heavy Extruded Aluminum  
Double Strength Glass  
Steel Ball Bearing Rollers  
Wood Grained Interior Knee Wall  
Optional Exterior Color

We also specialize in:

- Storms for Sliding Glass Door Walls
- Combination Storm & Screen Windows
- Prime Door Walls

"16 YEARS OF QUALITY EXPERIENCE AND SERVICE"

## Patio Door Sales, Inc. FACTORY SHOWROOM

25461 W. SEVEN MILE RD.  
REDFORD TWP., MICHIGAN 48240

538-6288

538-6212

License #21004

Area sports shorts

# Oasis remains unbeaten

Oasis Golf Center ran its record to 4-0 with a 10-0 shutout over previously unbeaten Kane's Truck Parts in a Livonia Women's Fast Pitch League softball game Friday night at Ford Field.

Oasis broke open a tight 0-0 duel in the fourth inning. Westland John Glenn All-Stater Jody Humphries started things off with a single to center field. She moved to second base on another single by Julie Stafford.

Both runners moved up on a well-executed bunt sacrifice bunt by Vickie Forest. Pitcher Dee Cifaldi followed with a two-run single.

Oasis then tallied three more runs in the sixth inning to take a commanding 5-0 lead.

Stafford walked and went to second on Cifaldi's second hit. Vicky Cavallaro and Jan Boyd also added singles to produce the three runs.

In the seventh inning, Garden City

East's Sherry Kiselica of Oasis started things off with a single. She scored on a triple by Humphries. Forest singled and Diane Connaughton walked to set up Stafford's dramatic three-run homer.

Cifaldi notched her third straight shutout of the season on a two-hitter. She struck out eight.

Oasis will face Daly Restaurant at 6:30 p.m. Friday at Ford Field. The Plymouth-based team will then meet the Dreamers at 6:30 p.m. also at Ford.

**LIVONIA WOMEN'S FAST PITCH SOFTBALL STANDINGS**

As of July 14

Team	W	L	T
Metro Merchants	5	0	0
Oasis Golf Center	4	0	0
Daly Restaurant	3	0	1
Stylerite	3	1	0
Gas House Gang	2	1	1
Mason's Lounge	2	2	1
Dreamers	2	2	1
Plymouth Elks	2	2	0
Gardella's Service	1	4	0
Plymouth Vivians	0	4	0
St. Agatha	0	5	0

# Canton net event slated

The Canton Township Parks and Recreation Department is holding registration for its annual Canton Open

Tennis Championships, now through July 29.

# Canton hosts Youth Fitness tilt

### YOUTH FITNESS MEET

The second annual Youth Fitness Meet, sponsored by the Canton Township Parks and Recreation Department, will be held Saturday at Centennial Educational Park Track.

Youngsters ages 7 through 15 are eligible to compete.

Local winners will be eligible to compete later this month in the State Youth Fitness Meet at Belle Isle representing Canton Township.

A mini-Olympics, for youngsters ages 7-9, will kick off the program at 9 a.m. Youngsters ages 10-11 will also begin at 9 a.m.

Competition for 12-13-year-olds and 14-15-year-olds will start at 1:30 p.m.

The Canton Youth Fitness meet features events in running, long jump, triple jump, softball throw and chinning.

Medals will be awarded to the first three finishers in each age group.

Interested participants are encouraged to register at the nearest summer playground facility. For more information, call 397-1000.

### RACQUETBALL LEAGUES

The Canton Township Parks and Recreation Department will sponsor two sessions of beginning racquetball lessons starting Thursday, July 24 at Rose Shores of Canton Racquetball Center.

Each class will meet one hour per week for five weeks. The cost is \$12.50 per person. Session I will be held at 10 a.m. The second session begins at 6:30 p.m.

Each session is limited to 12 persons. Classes will stress stroke technique, court play and basic rules.

Adult players are also invited to sign up.

For more information, call Dave Monk at 455-4225.

### SENIORS BOWLING LEAGUE

A new fall bowling league for senior citizens will begin at 10 a.m. Friday, Sept. 5 at Plaza Lanes.

Interested participants can obtain entry forms at the City of Plymouth Department of Parks and Recreation, 525 Farmer Street or Plaza Lanes, 42001 Ann Arbor Road.

For more information, call 455-6620 or 421-8040.

### PLYMOUTH NIGHT AT TIGER STADIUM

The Plymouth Department of Parks and Recreation will hold an "Evening of Tiger Baseball" Wednesday, July 30 at Tiger Stadium when the hometowners take on the California Angels.

The cost is \$9.25 per person which includes ticket and bus transportation. The bus will leave the Plymouth Cul-

tural Center, 525 Farmer Street, at 6:30 p.m.

For more information, call 455-6620.

**ROTTEN SNEAKER CONTEST**  
Who has the rottenest sneakers in the area?

That will be judged at 10 a.m. Saturday, July 26 in the second annual Rotten Sneaker Contest at the Canton Township Recreation Center, 44237 Michigan Avenue (at Sheldon Road).

All contestants will be asked to model their gym shoes in front of a panel of celebrity judges.

Winners, those with the worst-looking pair of sneakers, will receive a new pair of shoes as a prize.

Registration will be held at 9:30 a.m. Saturday, July 26 at the Recreation Center. Registrations can also be made by phone. Call 397-1000.

**MUSCULAR DYSTROPHY SOFTBALL TOURNAMENT**

Team openings are available for the annual Canton Muscular Dystrophy Softball Tournament to be held Aug. 8-10 at Griffin Park.

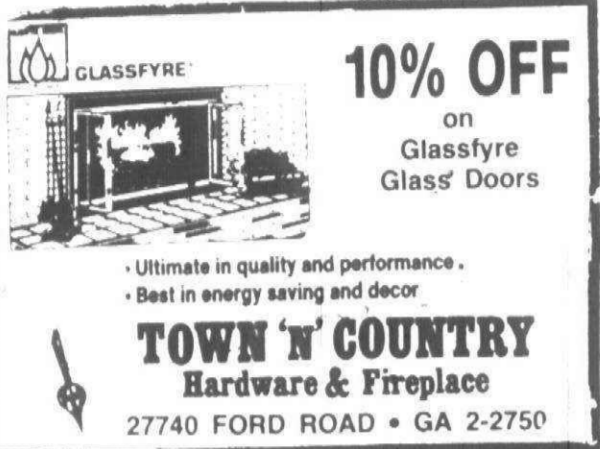

**GLASSYRE**  
**10% OFF**  
on  
Glassyre  
Glass' Doors

- Ultimate in quality and performance.
- Best in energy saving and decor.

**TOWN 'N' COUNTRY**  
Hardware & Fireplace  
27740 FORD ROAD • GA 2-2750

**STARTS JULY 28**  
SUMMER IN-STORE  
WAREHOUSE STYLE  
SKI EQUIPMENT  
SALE  
SUMMER  
DOOR BUSTER  
PRICES



**Bavarian Village**  
SKI SHOPS

**DO IT YOURSELF  
CONCRETE PROJECTS**  
MADE EASY WITH



**U-Cart**

- Free Trailers
- Save Time
- Save Money
- We're open 7 days
- Convenient U-CART Concrete  
1/4 yd. to 1 yd. at a time

**MAIN'S Pebble Place**  
39940 Grand River  
Novi  
477-9717

**Redford Bowling  
& Trophy Sales**

## WAREHOUSE SALE

Balls and Shoes  
No Dealers, Please

**5 Mile Store Only!**  
25268 5 Mile  
Redford  
**535-2300**

**Genie**  
**GS 459 D**  
Drive with Exclusive  
Sequensor™ "Computer-  
Controlled Brain."

**\$149 Plus Tax**



**CRYPTAR II**  
Digital Controls.  
Completely  
Solid-State.  
Meets all FCC  
Requirements.  
1 Yr. Parts Warranty

**Any Suburb**  
**ALLIANCE AUTOMATIC DOOR CO.**  
**358-3833 SOUTHFIELD**

# Erb Cashway Lumber..

## MEASURABLY BETTER

**WE'RE A YARD AHEAD OF THE REST!**

---

**BETTER LUMBER  
BETTER DECKS**



**WOLMANIZED LUMBER**  
10x14  
DECK... **\$199**

PRESSURE TREATED LUMBER SAFE FROM TERMITES OR ROT WHETHER YOU PAINT OR STAIN OR NOT

	8'	10'	12'	14'	16'
2x4	2.56	3.00	3.76	4.20	5.07
2x6	3.80	4.75	6.24	6.85	8.24
2x8	5.23	6.54	8.88	9.43	10.24
2x10	6.60	8.50	11.30	13.53	15.33
2x12	—	—	—	18.20	20.80
4x4	5.07	7.07	8.32	9.24	11.52
4x6	8.00	10.00	12.00	14.42	18.24

**BETTER SIDINGS  
BETTER HOMES.**



**DECORATOR SIDINGS**  
TEXTURE 1-11  
4'x8'x3/4" 4" O.C. **\$14.95** EACH

TEXTURE 1-11  
4'x8'x5/8" 8" O.C. **\$14.95** EACH

REVERSE BOARD & BATTEN  
4'x8'x3/4" 12" O.C. **\$15.95** EACH

**CLADWOOD SIDINGS**  
4'x8'x3/4" BOARD & BATTEN **\$9.75** EACH

**BETTER ROOFING  
BETTER PROTECTION**



**CELOTEX SHINGLES ARE AMERICAN MADE FOR AMERICAN HOMES. BUY QUALITY CRAFTED CELOTEX SHINGLES FOR YOUR RE-ROOFING PROJECT AND HELP OUR ECONOMY.**

**235 LB. SOL-SEAL SHINGLES**  
• SELF-SEALING TABS • 15 YR. (LIMITED) WARRANTY  
• 7 COLORS TO CHOOSE FROM • 3 BDLS - 1 SQ.  
• 1 SQ. COVERS 100 SQ. FT.

**\$22.95** SQUARE

**ROOF CEMENTS** **\$9.99**  
PLASTIC OR ASBESTOS.

---

**FENCING ON SALE**



**RUSTIC STOCKADE** 6'x8' SECTION **\$19.75** SEC.

**COLONIAL FENCE** 6'x8' SECTION **\$26.95** SEC.

**BASKETWEAVE** 6'x8' SECTION **\$34.95** SEC.

**DOORS ON SALE**  
**THERMA-TRU DOORS  
THE ENERGY-SAVER DOOR**

**100 FLUSH DOOR** 2'8" OR 3'0" x 6'8" REG. \$144.75 **\$119.95**

**223 X-BUCK DOOR** 3'0" x 6'8" REG. \$191.25 **\$159.95**

**HANDI-BARN**  
FOR THAT EXTRA ADDED STORAGE SPACE YOU NEED FOR ALL YOUR LAWN & GARDEN EQUIPMENT

KIT INCLUDES:  
• 235 LB. SHINGLES • FLOOR  
• TREATED FLOOR JOISTS

**8'x8' BARN** **\$299**  
**10'x10' BARN** **\$399**

INCLUDES FLOOR

---

**COOLING BLUES?**  
THINK OWENS CORNING FIBERGLAS INSULATE NOW WITH PINK OWENS CORNING FIBERGLAS INSULATION YOU'LL SAVE PLENTY ON AIR CONDITIONING ENERGY THIS SUMMER. KEEP YOUR HOME FUEL BUDGET UNDER CONTROL NEXT WINTER TOO!

3 1/4" x 15" KRAFT R-11 COVERS 88.12 SQ. FT./ROLL **\$11.75** ROLL

6" x 15" KRAFT R-19 COVERS 48.96 SQ. FT./ROLL **\$10.75** ROLL

6" x 15" ATTIC R-19 COVERS 48.96 SQ. FT./ROLL **\$9.99** ROLL

THE HIGHER THE R-VALUE THE GREATER THE INSULATING POWER. ASK US FOR THE FACT SHEET ON R-VALUES.

**ALUMINUM COMBINATION DOORS**

**WHITE CROSS-BUCK**  
• 3'0" x 2'8"  
• 6'8" HIGH  
• SAFETY GLASS  
**\$54.95**

**WHITE SELF-STORING**  
• 3'0" x 2'8"  
• 6'8" HIGH  
• SAFETY GLASS  
**\$69.95**

**PINE BOARDS**

1x4"-6' 89¢ 1x10"-6' \$2.40  
1x6"-6' \$1.39 1x12"-6' \$3.78  
1x8"-6' \$1.79

---

**DIMENSION LUMBER**  
ASSOCIATION GRADE STANDARD AND CONSTRUCTION LUMBER

	6'	8'	10'	12'	14'	16'	18'	20'
2x4	.93	1.25	1.87	2.32	2.52	3.15	4.02	4.47
2x6	1.86	2.48	2.95	3.78	4.20	5.12	6.12	6.80
2x8	2.40	3.20	4.00	5.80	6.35	7.04	8.64	9.87
2x10	3.05	4.07	5.17	7.30	8.22	10.13	12.30	13.67
2x12	4.56	6.08	7.60	9.12	10.64	12.16	17.28	19.20

**ANDERSEN WINDOWS**  
THE ENERGY SAVING WINDOW

• EXTERIOR RIGID VINYL IS DESIGNED NOT TO RUST, PIT OR CORRODE • WOOD CORE PROVIDES SUPERIOR INSULATION • DOUBLE PANE INSULATING

MANY STYLES TO CHOOSE FROM  
**30% OFF**  
MANUFACTURERS SUGGESTED LIST

**PLYWOOD SPECIALS**

4'x8' SHEETS	GOOD ONE SIDE	CDX PLYWOOD	PARTICLE BOARD
3/4"	9.39	—	—
5/8"	13.25	7.89	5.99
1/2"	14.45	8.39	6.49
3/8"	15.95	11.95	6.99
1/4"	17.95	14.75	6.99

---

**REDI-MIX CEMENT**



**90 LB. BAGS**  
**\$2.77** BAG

**WAFERWELD ROOF & SIDEWALL SHEATHING**



**4x8x7/16"**  
**\$5.29** EACH

**DRYWALL**



**4'x8'x3/8"**  
**\$2.67** EACH

---

**LANDSCAPE TIMBERS**



**3"x5"x8"**  
**\$3.47** EACH

**5" ALUMINUM K GUTTER**



YOUR CHOICE WHITE OR BROWN  
8' LENGTH  
**\$3.99** EACH

**PICNIC TABLES**



INCLUDES TOP, SEATS, HARDWARE & FRAME  
8' TABLE  
**\$44.95**

---

**ROYAL OAK**  
803 S. MAIN CORNER OF LINCOLN  
**548-2153**

**PONTIAC**  
888 ORCHARD LK. RD. JUST EAST OF TELEGRAPH  
**334-1511**

**MT. CLEMENS**  
35679 GRATIOT NORTH OF 15 MILE  
**792-7770**

**WARREN**  
24620 SCHOFER RD. JUST SOUTH OF 10 MILE  
**775-7000**

**LIVONIA**  
11970 FARMINGTON RD. BETWEEN SCHOOLCRAFT AND PLYMOUTH  
**261-5110**

**SCHOOLCRAFT**  
PLYMOUTH

**CASH & CARRY PRICES GOOD WHILE QUANTITIES LAST THRU 7-22-80**  
SIZES ARE TO BE INTERPRETED AS APPROXIMATE. ILLUSTRATIONS MAY NOT NECESSARILY SHOW EXACT PRODUCT.

**STORE HOURS:**  
MON. FRI. 8 5-30  
SAT. 8 4  
SUN. 10 3

# McMurray Insurance extended

McMurray Insurance held onto its game-winning policy last week by edging stubborn Canton Sports, 17-16, in a Canton Recreation Class A men's slow pitch softball game.

McMurray, now 6-0 in the second round, won the game in the bottom of the seventh inning on Tom Battistone's RBI double. It capped a field day at the plate for the McMurray slugger. He also had two homers and six RBIs.

In other Class A games, second-place Silver Cricket bombed C&M Truck Collision, 11-2, as Jerry Nastally had a homer and four RBIs. Jim Wetmore and Gary Mooney each added three hits.

Nastally, was even more effective on the mound as he allowed just five hits while retiring the last 12 C&M batters.

Third place Player's Lounge totaled 19 hits in a 20-8 victory over Oakview Party Store.

Al Jose collected two homers and four RBIs for the winners. Teammate Bob Tomajouski added a homer, double, single and four RBIs.

**MIKE WARD** batted in five runs to power Bonanza-12 Oaks to a 13-11 Class C Division IV win over MAACO.

Ward's two-run homer in the bottom of the seventh provided the winning margin, sending Charo's team home a loser.

Richard Benoit collected four hits and four RBIs to give the Canton Jaycees a 9-5 triumph over Carinci's Beer Stein and Wine. It was the first win of the second round for the Jaycees.

St. Michaels remained unbeaten in Division IV play with a 7-4 win over Amoco Quick Six.

**IN CLASS C Division V** play, Ventcon hit the .500 mark with a 13-7 victory over John and Dude's Towing.

Dave Ogle had three triples and two singles for the winners, now 2-2 overall. Ventcon scored five runs in the seventh to put the game away.

Pellegrino's Sales whipped Brugalio's Studios, 6-1.

### CANTON RECREATION SLOW PITCH SOFTBALL STANDINGS

As of July 11

MEN'S A LEAGUE			
W	L	GB	
McMurray Insurance	6	0	
Silver Cricket	5	1	
Player's Lounge	4	2	
Canton Sports	2	4	
Oakview Party	1	5	
C & M Truck	0	6	

MEN'S B LEAGUE			
Division I			
Rusty Nail	5	0	
Rose Shores	3	1	1 1/2
Jake's Lounge	2	2	2 1/2
Ovidon	1	4	4 1/2
Trident	1	4	4 1/2

Division II			
All Star Pro	5	0	
Chapman Bros	4	1	
Brewers	2	3	
Margie Rae	2	3	

### MEN'S C LEAGUE

Division I

Roman Forum	1	0
Canton Bowling	1	0
Superbow!	0	1
Cherry Hill	0	1
Drapery Trad	0	1
Century 21	0	1

Division II			
K & C Const	5	0	
Lon & Sword	4	1	
Rusty Nail	3	2	
Clas'73 Chassis	2	3	
Canton Cougars	1	4	
Maria's Bakery	0	5	

Division III			
Howell Indus	1	0	
Falzon Electric	1	0	
Geneva Church	1	0	
Cal Sign Co.	0	1	
Car Pro	0	1	
Mich-I-Van	0	1	

### Division IV

St. Michael's

Bonanza-12 Oaks	4	0
Carinci's Beer	3	1
Jaycees	1	3
Amoco Quick	1	4
MAACO	1	4

Division V			
J & D's Towing	4	0	
Statewide Aluminum	3	0	
Pellegrino's	2	2	
Ventcon	2	2	
Brugalio's	1	3	
Denny's Service	0	5	

WOMEN'S LEAGUE			
Gold Realtors	5	0	
Rusty Nail	4	1	
Do-Rite-Duds	4	1	
Pelouquin East	3	1	
Practical Home	3	1	
Classy Chassis	2	2	
Titan Steel	1	3	
Maria's Bakery	1	4	
Jack's Sports	0	5	
W.E. Hennels	0	5	

# Bozyk brothers rule bat contest

The Bozyk brothers, Keith and Scott, claimed two of six titles Sunday at Griffin Park in the annual Pitch, Hit and Run Contest sponsored by Burger King Restaurants and the Canton Township Parks and Recreation Department.

Keith captured first place honors in the Boys 8 Division while Scott won the Boys 12 Division.

More than 200 youngsters competed in the event for ages 8-13.

Scott had the highest point total among all participants with 394. He was particularly impressive in batting where he slugged the ball 194 feet. It was the longest shot of the day.

Chris Johnston was perfect in the pitching phase en route to a victory in the Boys 9 Division. He totaled 252 points. Mark Munro was second in the Boys 9's with 202 points. Eric

Mayer was second in the Boys 8's with 229.

Tim Dowd was clocked in 12.8 around the bases and went on to win the Boys 11 Division with 295. Steve Bennett was a close second (282).

Christopher LaBond finished second behind Bozyk in the Boys 12's with a total of 244.

The Boys 13 Division crown went to Richard Curtis, who took first in hitting and running events. He scored 295 points, edging runnerup David Knapp (286).

In the Boys 10 Division, first place was grabbed by Jeff Beard with a 255 total. Bob Files was second with 249.

The Bozyk brothers, Johnston, Beard, Dowd and Curtis now advance to district competition in Warren, July 26.

## CHIMNEYS

- Cleaned
- Screened
- Repaired
- Built New

### Roofs

- Repaired
- Re-Roofed
- New
- Leaks Stopped

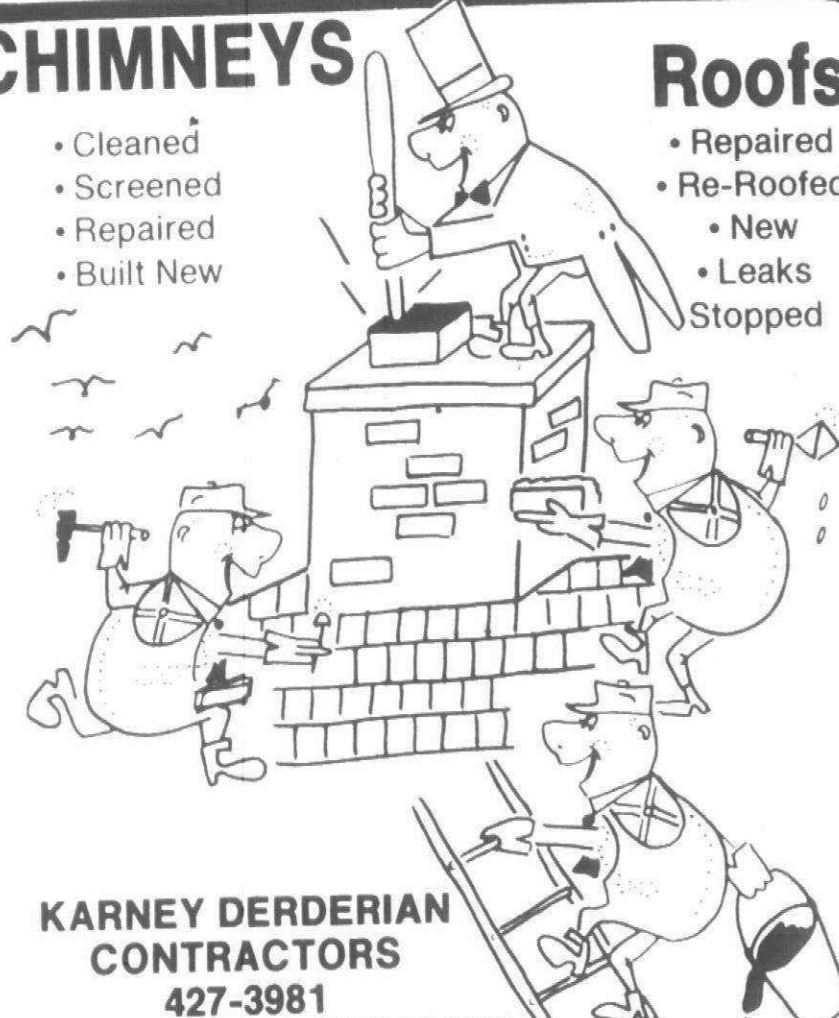

**KARNEY DERDERIAN CONTRACTORS**  
427-3981  
LICENSED • INSURED • GUARANTEED

**RENT**

**a RABBIT**

also  
**PICKUP-VANAGON**



DAILY-WEEKLY-MONTHLY

**RENT**

**a BOLER**

TRAVEL TRAILER



TOW BY ANY CAR

Sleeps 4

ATTRACTIVE RATES

**LIVONIA VOLKSWAGEN, INC.**  
34501 Plymouth Rd.  
(Between Wayne & Farmington Rds.) 425-5400

**MAIN'S Pebble Place**

IN STOCK  
Oversize 2-6"  
Multi-color

- SAND
- STONE
- WOOD CHIPS
- TOP SOIL
- LANDSCAPE STONES and MATERIAL

**LANDSCAPE ROCK**

**SPECIAL THIS WEEK**

COBRA HEAVY DUTY BLACK  
**PLASTIC LAWN EDGING**

Reg. \$14.75 NOW **\$10.50** 20 ft.

39940 Grand River-west of Haggerty  
Novi 477-9717 477-9420

*"Sold by the bushel or the yard"*

# 25 MILES PER GALLON AND THE PERFORMANCE OF A BMW.

At a time when the national conscience is consumed with fuel efficiency, the BMW 320i is truly remarkable. With 5-speed standard transmission the 320i delivers 25 EPA estimated mpg and 36 estimated highway mileage.\*

Yet, what makes the BMW 320i even more impressive is that it achieves these mileage figures without ever violating the one thing that makes the car worthy of the BMW name—extraordinary performance.

Press the accelerator and you'll immediately see what we mean. The four-cylinder, 1.8-liter, fuel-injected overhead cam engine responds with a force that is exhilarating even by pre-pollution control standards.

On winding roads and tight turns the legendary BMW suspension system—independent on all four wheels—makes one feel as though the car were slotted into the roadway.

The interior of the 320i is equally

sophisticated. With every facet strategically planned to help eliminate driver fatigue.

Before you commit yourself to any one of today's increasingly mediocre cars, commit yourself to a test drive in a BMW 320i.

It's proof that performance and efficiency can co-exist under the same hood.

**THE ULTIMATE DRIVING MACHINE.**  
BMW MUNICH, GERMANY

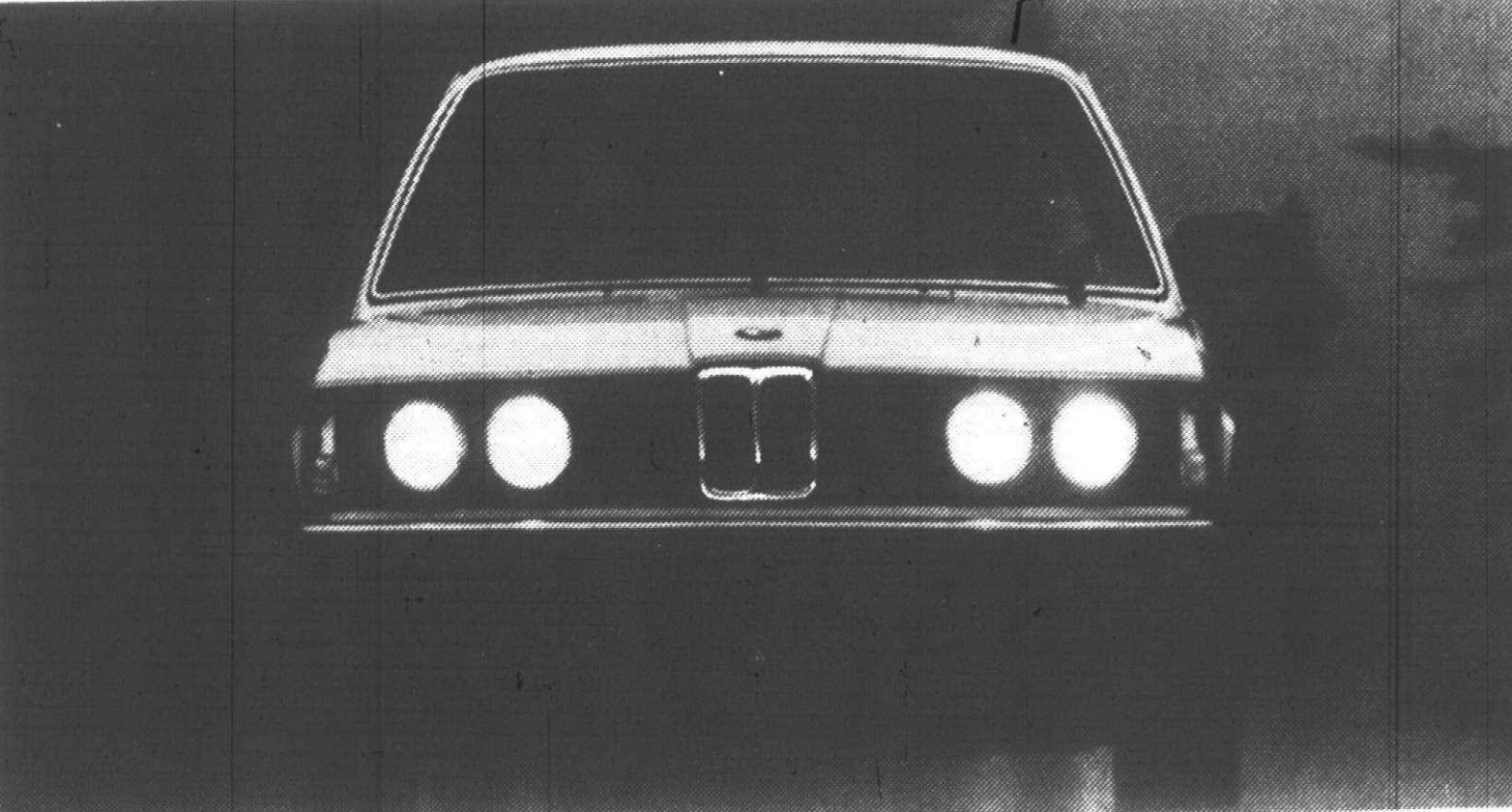

\*Our fuel efficiency figures are for comparison purposes only. Your actual mileage may vary, depending on speed, weather and trip length. Your actual highway mileage will most likely be lower. © 1980 BMW of North America, Inc. The BMW trademark and logo are registered trademarks of Bayerische Motoren Werke, A.G.

THE DETROIT AREA BMW DEALER GROUP

**ANN ARBOR**  
ARCURE MOTORS, INC.  
617 Detroit St.  
(313) 663-3309

**EAST DETROIT**  
BAVARIAN MOTOR VILLAGE, LTD.  
24717 Gratiot Ave.  
(313) 772-8606

**FARMINGTON/DETROIT**  
ERHARD MOTOR SALES  
32715 Grand River  
(313) 477-6405

## SALEM LUMBER CENTER

Your Neighbor Shops Here

Now, building a patio or pool deck is so easy...  
ANYONE CAN DO IT! with...

**WOLMANIZED LUMBER**



**8x16 DECK \$199<sup>88</sup>**  
(LUMBER ONLY)

**LET US QUOTE YOU ON ANY SIZE DECK**

Does not include hardware, cement, railing or steps.

WOLMANIZED PONDEROSA PINE

	10'	12'	14'	16'
2x4	3.07	3.94	4.57	5.46
2x6	4.90	5.44	6.84	7.84

1x6-6 Wolmanized Boards \$1.19 ea.

**LANDSCAPE TIMBERS**

All Wolmanized Sq. Edge

3"x3" - 8'	\$2 <sup>99</sup>
4"x4" - 8'	\$4 <sup>99</sup>
4"x6" - 8'	\$5 <sup>88</sup>

**STOCKADE FENCE**

5x8 SECTIONS  
All Cedar  
**\$17<sup>88</sup>**  
C.C.

6x8 SECTIONS  
**\$19<sup>88</sup>**  
Spruce

**7' Cedar Posts \$3<sup>33</sup>**  
with one flat side for 5' sections  
We have several types of .8' posts for the 6' sections

*Give the garage back to your car!*  
**Store it in Arrows**  
**new dynamic storage shed**



**COLONIAL OLIVE PANELS WITH-DARKER OLIVE DOOR. GREENBRIAR**

**\$144<sup>88</sup>**

STEEL CONSTRUCTION 10'x6' 10' WIDE (DOOR SIDE) x 6' DEEP

•Solid Year-Round Protection 10'x9' \$174.88  
•Innovative Styling•Easy Assembly

**BASKETBALL BACK BOARD \$10<sup>88</sup>**  
SIZE 32"x48"  
Solid 3/4" Exterior Plywood Ready to Mount & Paint



Patio Queen

## Picnic Table

Do it yourself and save!



**\$26<sup>88</sup>**

ORNAMENTAL IRON FOLDING TABLE HARDWARE Lumber Extra

Will Make 6', 7' or 8' Table

**Other Patio Beauties**



GARDEN QUEEN BENCH



PATIO & PORCH SWING SET



CHAISE LOUNGE



PATIO & PORCH GLIDER

All models on display

**HARDWOOD PLYWOOD FULL SHEETS OR LESS**



WHY BUY FULL SHEETS?

	2x4	4x4	4x8
3/4" LAUAN	2.75	5.50	10.19
1/2" LAUAN	7.22	14.44	28.88
3/4" LAUAN	10.00	20.00	39.88
1/2" BIRCH	7.50	15.00	29.88
3/4" BIRCH	9.22	18.44	36.88
3/4" OAK	11.15	22.30	41.59

**PIECE PRICE SHOWN**

For Wood Gourmets

**NEW SHIPMENT 1/2" HARDWOOD LUMBER**

	4'	5'	6'	8'
OAK, CHERRY, PECAN, ASH	1.00	1.50	2.00	2.50
WALNUT	1.50	2.25	3.00	4.00

Price per lineal foot shown. For furniture, shelves, boats, etc.

**SOFTWOOD**

2 x 4 STUDS

7' 69¢

8' 89¢

SELECT YOUR OWN FROM OUR IN-STORE STOCK

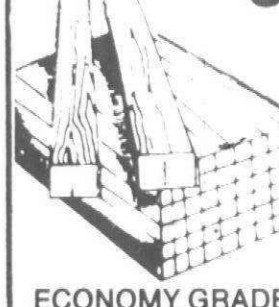

**ECONOMY GRADE KD**

**30650 PLYMOUTH ROAD**  
**GA 2-1000**

Store Hours  
Monday thru Friday 9 a.m. - 8 p.m.  
Shed open Monday, Thurs., Fri. til 8 p.m.

Saturday 9 a.m. - 6 p.m.  
Sunday 10 a.m. - 5 p.m.

### in the pocket/W.W. Edgar

The merger of the American Junior Bowling Congress and the Youth Bowling Association moved a step closer last week at the proprietors' national convention in Las Vegas.

The proprietors, who organized the Youth Bowling group almost two decades ago to provide opposition for the AJBC voted unanimously to join forces with the AJBC that was sponsored years ago by the American Bowling Congress.

All that remains now is for the American Bowling Congress to take the floor to plead for the joint program.

Recently the Women's International Bowling Congress voted for the combine, but only after it first turned it down and then heeded a plea from Mrs. Alberta Crowe, the national president.

Mrs. Crowe surprised her convention when she turned the gavel over to her vice-president and then took the floor to plead for the joint program.

The big surprise was the proprietors' approval in that they had been the sponsors of a program that not only included leagues on the local level but also instituted the National Youth tournament that was held in Washington, D.C., for many years.

If the ABC approves the merger, the youth association will be one of the biggest groups in the bowling game.

**AL WINKEL**, former president of the Bowling Proprietors Association of Greater Detroit, moved up a step on the national ladder last week.

He was elected regional vice-president of the Bowling Proprietors Association of America at the national meeting in Las Vegas.

As regional vice-president he will supervise the area that includes Michigan, Ohio and Indiana. He is thoroughly familiar with the bowling game as he and his brother, Bill, have owned Mont Carlo for years and now have added Woodland Lanes, Bel-Aire Lanes and Mayflower Lanes.

**KEN KOSSICK** staged a great finish to take top honors in the Monday Trio league at Bel-Aire Lanes.

After opening with 223, he slipped to 185 then finished with counts of 279 and 233 for 930. The 279 was the high game of the night.

Reggie Donnard landed in the runner-up spot with 870 gained on games of 202, 192, 256 and 220.

**THE AREA** establishments have been notified that Miller High Life again is sponsoring the national doubles tournament and there will be qualifying rounds in every community.

The finals are scheduled for Las Vegas with \$50,000 available in prize money.

### We're the best kept secret in Detroit!



Although there's nothing secretive about being the 4th largest pizza company in the country, (in terms of pizza sales) we've grown so fast, at a rate of over 40% each year, that many people still may not know about us.

When they find out that by investing \$9,500 cash (our total franchise fee) and by qualifying for financing of \$40,000 to \$50,000 they may be eligible for a Domino's Pizza franchise, they want to know more!

They are surprised to find that a franchise relationship with Domino's Pizza includes a professional training program, advertising expertise, site selection and store opening assistance.

We have over 300 stores located in 30 states and are now going international. We're a secret you don't have to keep to yourself!

Write or call today.

David K. Kilby  
Director of Franchising  
Domino's Pizza, Inc.  
3853 Research Park Drive  
Ann Arbor, Michigan 48104  
313/668/4000

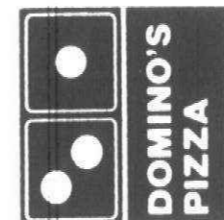

©Copyright 1980 Domino's Pizza, Inc.

IT IS UNLAWFUL TO OFFER OR SELL ANY FRANCHISE WITHOUT PROVIDING YOU A DISCLOSURE CIRCULAR AT LEAST 10 DAYS PRIOR TO EXECUTION OF ANY BINDING CONTRACT OR PAYMENT OR ANY CONSIDERATION OR AT THE TIME OF YOUR FIRST MEETING WITH OUR REPRESENTATIVE WHICHEVER IS EARLIER.

### JOIN THE SKI STAFF AT Bavarian Village SKI SHOPS

If you think you'd be a good salesperson, we would like to talk to you. Applications being accepted Thursday evening, 7-9 PM at these Bavarian Village Ski Shops.

Bavarian Village is looking for some sharp people who would like to sell ski equipment and clothing in Michigan's finest ski shops. Immediate openings.

- Part time — 20-30 hours
- Workshop openings — full & part time
- Full time — seasonal
- 4-8 months seasonal
- We can fit your schedule



**BIRMINGHAM:** 101 TOWNBEND cor. Pierce 644-9860  
**LATHRUP VILLAGE:** 20845 BOUTFIELD at 12 MI. 658-2380  
**FARMINGTON:** 34788 GRAND RIVER East of Drake 477-2528  
**EAST DETROIT:** 22301 KELLY RD. bet. 8 & 9 MI. 778-7020  
**ANN ARBOR:** 3338 WABHTENAW, W. of US 23 973-9340

### NORTON TWIN 200 Sunday, July 20, 1980

200 MILE INDY-CAR RACE

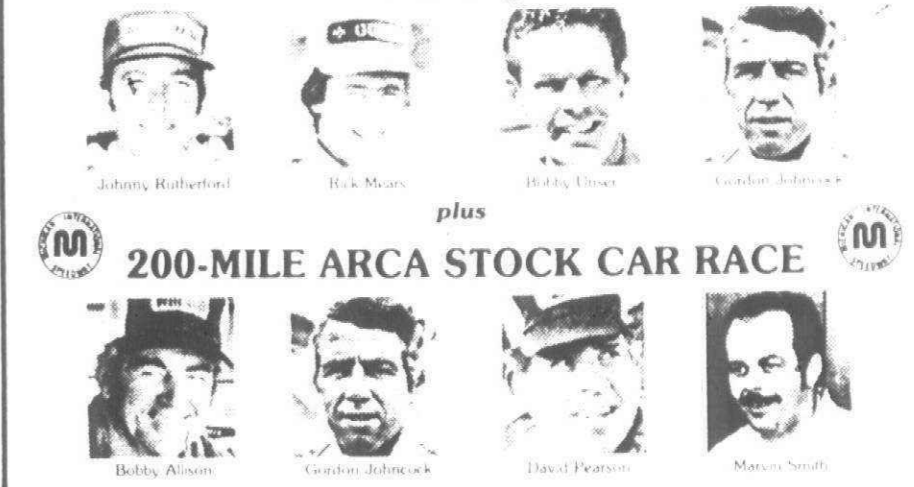

### 200-MILE ARCA STOCK CAR RACE

John Rezek, ARCA 200 Winner at Daytona; Moose Myers, Delmar Clark

### Saturday, July 19 the \$22,000 Toyota Pro Challenge

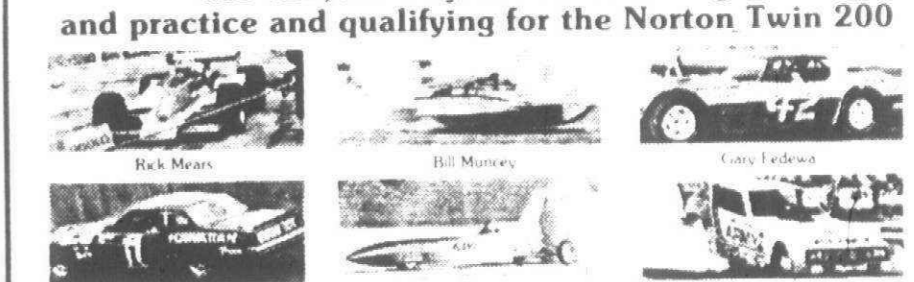

Six of the top names in a variety of motorsports take to the high banks for a 20-mile sprint.  
For ticket information call 517-592-6671 or 313-961-1922

**SUMMER SPECIAL VALVE JOB**  
Does your Car run bad after a Major Tune-Up? Your Engine could possibly need a Valve Job. Free Analysis and Leakdown test. Most V-8's, complete valve job, parts and labor \$290. Reg. \$450.00. Includes Oil Change and durable Silicon-bronze valve guides!  
**JULY SPECIAL ON PARTS**  
• Oil Pumps (OEM) From \$18.95  
• Hi-Volume From \$24.50  
• V-8 Ring Sets (Plasma-Moly) From \$39.95  
• General Kinestics Cam Shafts from \$48.00  
**O.K. CYLINDER HEADS**  
9992 General Dr.  
So. of Ann Arbor Road  
Bet. Haggerty & Lilley  
Plymouth, MI  
459-6020

**FAMILY CAMPING CLOSE TO HOME**

- CAMPING • HIKING TRAILS
- SPRING FED LAKE • SANDY BEACHES
- GROUP RATES • CAMPFIRE PITS
- WILD ANIMAL MUSEUM
- EXOTIC GAME PRESERVE

Take a guided tour over rolling hills in a covered wagon through a preserve. See herds of Buffalo, Elk, Corsian Ram, Whitetail Deer and many other wild animals in this natural habitat.

**TIMBERLAND GAME RANCH**  
12780 N. TERRITORIAL RD.  
DEXTER, MICH.  
(313) 475-8679



## There's Only One "Oh" In Detroit!



**I**t's WOMC FM104 — affectionately known as "Detroit's Big Oh." And there's no other radio station in Detroit quite like it.

For oh-peners, WOMC lightens up your day with your favorite personalities. Down-to-earth, entertaining Detroit favorites like Marc Avery from 6 to 10 AM and Tom Dean from 10 to 2 PM.

But that's not all—oh no. "Detroit's Big Oh" also keeps you up-to-date with exclusive Accu-Weather reports, the latest traffic reports, national and local news—even live broadcasts of University of Detroit basketball.

Oh... and we almost forgot WOMC plays your kind of music. No funk, no punk and no junk. Just good music—and lots of it. Everything from Bob Dylan to Barbra Streisand.

So turn your dial to WOMC FM104 today. It's a Detroit oh-riginal!



"Detroit's Big Oh!"

M.I. METROMEDIA INC.

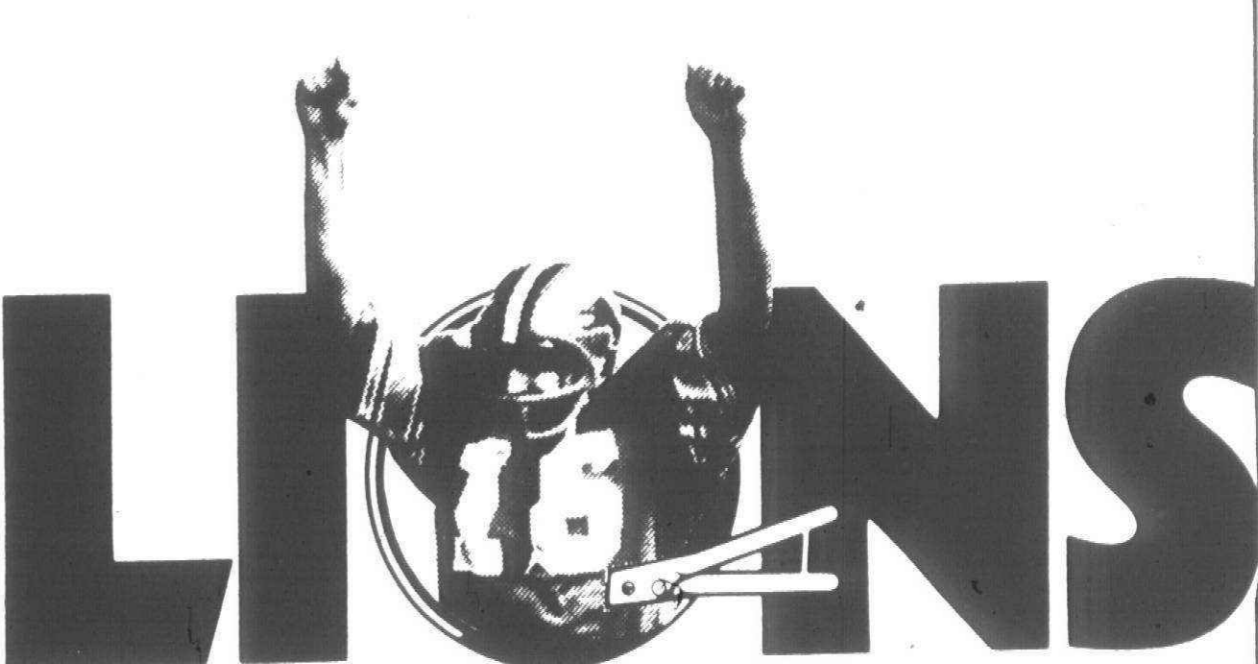

### Get Ready For The Roarin' 80's!

The Lions head into the new decade with new enthusiasm and optimism. Veteran stars such as Gary Danielson, Al Baker and Doug English will be joined by a crop of promising newcomers led by number one draft choice Billy Sims. Monday, July 21 is the day tickets for all Lion home games go on sale. So pick the game or games you wish to attend, get your tickets early, and get ready to join the Lions as they ROAR into the 80's.

SEASON TICKETS are still available. You are assured the same fine seat for all 10 games with your season ticket purchase. Drop by our Silverdome office or call (313) 335-4151 for information.

**INDIVIDUAL GAME TICKETS** go on sale at the Silverdome and all Lion ticket outlets Monday, July 21. For the sixth straight year, ticket prices remain at \$10.00. If you can't find time to visit any of our ticket agencies, just fill in the form below and mail it with your check or money order.

**Official Lion Ticket Agencies:**

BATTLE CREEK: Coles, 64 W. Michigan  
BAY CITY: Mutual Savings and Loan, 623 Washington  
JACKSON: L.H. Field, 201 W. Michigan  
LANSING: VanDervoorts, 1515 N. Grand River  
MIDLAND: Al's Sports, 1908 S. Saginaw  
PORT HURON: Smokers Haven, 412 Huron  
SAGINAW: Pro-Am Sports, 3514 State  
WINDSOR: Freed's Clothing, 1526 Ottawa  
DETROIT: Sportsland, USA, 1444 Michigan

J. L. HUDSON'S (DETROIT AREA): Downtown, Fairlane, Eastland, Northland, Westland, 12 Oaks, Southland, Lakeside, Oakland Mall, Pontiac Mall  
ANN ARBOR: Briarwood, FLINT: Genesee, GRAND RAPIDS: Woodland, SAGINAW: Fashion Square, TOLEDO: Franklin Park, LANSING: West Lansing Mall

**1980 Lions Home Game Schedule**

Date	Time	Opponent	No. of Tickets
Aug. 16	8:00 p.m.	Buffalo Bills	
Aug. 23	8:00 p.m.	New Orleans Saints	
Sept. 21	1:00 p.m.	St. Louis Cardinals	
Sept. 28	1:00 p.m.	Minnesota Vikings	
Oct. 12	4:00 p.m.	New Orleans Saints	
Nov. 2	1:00 p.m.	San Francisco 49ers	
Nov. 16	1:00 p.m.	Baltimore Colts	
Nov. 27	12:30 p.m.	Chicago Bears	
Dec. 14	4:00 p.m.	Tampa Bay Buccaneers	
Dec. 21	1:00 p.m.	Green Bay Packers	

Send me a total of \_\_\_\_\_ tickets @ \$10.00 each for the games I've checked. I've enclosed my check/money order for \$ \_\_\_\_\_ (U.S. funds only).

Make check payable to: DETROIT LIONS, INC. Mail with order form to: LIONS TICKETS, BOX 4200, PONTIAC, MI 48057. Please enclose self-addressed, stamped envelope for speedier return.

NAME \_\_\_\_\_ ADDRESS \_\_\_\_\_

CITY \_\_\_\_\_ STATE \_\_\_\_\_ ZIP \_\_\_\_\_

BUSINESS PHONE \_\_\_\_\_ HOME PHONE \_\_\_\_\_



### Livonia Adray League roundup

# Redford Adray sweeps Griffin's

Redford Adray, which had been in a taltspin the last couple of weeks in Livonia Adray League baseball play, broke out of the doldrums by winning two of three games last weekend.

Redford divided a double-header with Waterford Auto Workers Insurance (AWI), winning the first 2-1 and dropping the second 9-5. Earlier, Redford nipped Livonia Adray 5-4.

"Our defense pretty much collapsed and our bats were quiet," explained Redford manager Don Petersen. "Our pitching was pretty good."

AWI scored its only run in the first game of the twin bill during the first inning. Redford tied the proceedings in the fourth inning when Kirk Hunter cracked a solo home run.

Redford notched the winning run in the sixth inning. Matt Etienne walked, Hunter singled and Paul Dillon singled. Hunter singled twice in addition to pounding the home run. If that weren't

enough, he also gained the pitching victory. Hunter struck out seven, walked three and allowed only three hits. He hurled all seven innings.

Redford slipped into some bad habits in the second game — four errors — and fell 9-5.

Redford scored all five of its runs during the fourth inning. The big hit was a two-run home run by Hunter. Redford put together four hits and a pair of walks, as nine men batted.

Redford led 5-3 at that point, but AWI came up with six runs during the last half of the fourth inning to pull away.

Doug Holloway, who was relieved by Matt Etienne in the fifth inning, sustained the pitching loss.

Earlier, against Livonia, Redford rallied from a 4-2 deficit with three runs in the fifth inning to score a 5-4 victory.

Jim Vincentini slapped a two-run single to knock in the tying and winning runs for Redford.

Brian James was the winning pitcher. He struck out four and didn't allow a walk in seven innings of work.

Mike Migosky took the loss. He was replaced by Dan Webster in the fifth inning.

Livonia out-hit Redford 7-6. Jim Wilson singled three times for Livonia. Don Dreher tripled and Hunter doubled during the game for Redford.

AFTER LOSING to Redford, Livonia split a doubleheader with Wendy's. Livonia won the first game 10-9. Each team totalled 11 hits.

It was kind of a wild game from the start. Wendy's led 3-2 after the first, Livonia 4-3 after the second and

the score was tied at four after three innings. Wendy's produced five runs during the fourth inning, Livonia five in the fifth.

The difference in the game turned out to be the run Livonia scored in the fourth inning.

Jerry Sergits was the winning pitcher. Jeff Switalski was the loser.

Steve Nowak punched three hits for Wendy's, Shawn Boyea and Bill Kopanakis two apiece.

Nowak pitched Wendy's to a 5-1 victory in the second game. Nowak struck out eight, walked only one and scattered six hits. Art Wentt was the losing hurler.

Paul Assenmacher accounted for two of Wendy's seven hits.

## Patt's pads lead in Garden City loop

Patt's Printing extended its first-place lead in the American Division of the Garden City Class A Invitational Baseball League to four games last weekend with a 12-3 pounding of Neal's Safety Sewer.

Patt's totalled 15 hits and reaped three runs during the first inning, three in the second, four in the fourth and two in the sixth.

Craig Walker blasted a two-run home run and Wayne Traver followed with a solo home run to get Patt's off and running in the first inning.

Traver later rapped two doubles and finished with four runs batted in. Walker also singled twice and totalled three RBIs.

Frank Corej doubled and singled and Otis Manning and Joe Saunders each singled twice.

Neal's scored all three of its runs during the second inning.

No one had more than one hit during the game for Neal's, which collected six.

Art Wentt pitched the first five innings and recorded the victory. Jim Leadford worked the last two frames. Al Anderson, the first of three Neal's hurlers, took the loss.

Jim Kay and Jim Beyer also pitched for Neal's.

ALUMNUS outlasted A&K Electric 10-9. It wasn't exactly the most well-played game of the season. A&K committed nine errors, Alumnus eight.

Alumnus scored the winning run in the last half of the ninth inning. Joe Korona was safe at first base on an error, stole second and scored on a single by Mark Baker.

A&K rallied late, scoring three runs during the sixth and three more in the seventh innings to extend the game. Tim Brady cracked a two-run triple in the sixth, Ed Van Hoff a two-run single in the seventh.

Alumnus' most-productive inning was the fifth when it exploded for sixth runs. Ten men went to the plate. John Umlauf unloaded the big hit — a three-run triple.

Each team scored in the ninth inning — Alumnus on an error and A&K on a single by Roy Bambach.

Jerry Trybus, who relieved Gary Skladzien in the sixth inning, was the winning pitcher. Roy Bambach, in relief of Bob Sabourin, took the loss.

## Plymouth softball stats

PLYMOUTH RECREATION SOFTBALL STANDINGS			Class B League			Vic-Tech							
	W	L	GB										
As of July 14	10	2	1 1/2	Poppin Fresh	10	1	6	7 5/8					
MEN'S SLOW PITCH	10	4	2	Heidenreich	10	2	1/2	Worthington	4	9	7 3/4		
	9	4	2 1/2	Dunn Steel	9	2	1 1/2	Hines Park	4	9	7 1/2		
	9	4	2 1/2	Cash Builders	11	3	1 1/2	Gene's Express	4	9	7 1/2		
	9	5	3	R&L	5	7	5 1/2	Galaxy Boring	3	10	8 1/2		
	6	8	6	Bayliff	4	9	7						
	5	9	7	Vispac	4	9	7						
	4	10	8	A.S.C.	2	11	9						
	12	2		Magic	2	13	11						
Massey Cadillac	12	2											
Century 21	10	4	2										
M.B.M.	9	4	2 1/2										
Finlan	9	4	2 1/2										
Pickett	9	5	3										
H.A.F.	6	8	6										
Wagner Electric	5	9	7										
Sheehan	4	10	8										
				Class C League									
				Partly Pantry	11	1	6	7 5/8					
				Box Bar	9	2	1 1/2						
				Pace Dairy	9	3	2						
				WOMEN'S SLOW PITCH									
				Trading Post	11	1	6	7 5/8					
				J.R.'s Raiders	9	2	1 1/2						
				Daly's	9	3	2						
				Airt Title	6	4	4						
				Glenn's Collision	6	6	5						
				Quik Pak Inc.	4	9	7 1/2						
				Gosh's Pee Wees	1	11	10						
				ACMIC	1	11	10						

## Rock golf grad qualifies

(Continued from Page 1C)

37 — Lawrence LaCarter (Livonia); John Rigelsky (Plymouth); Larry O'Connor (Birmingham); Robert Wilson (Plymouth); Eugene Bonk (Livonia); Mauro Velilla (West Bloomfield).

38 — Alan Cameron (Troy); Douglas Tousey (Rochester); Chris David (Redford); Jerry Walsh (Livonia).

39 — Daniel Ressler (Westland); Kevin Brown (Westland); David Poisson (Redford); Todd Brunsink (Redford).

40 — Chuck Wadowski (Canton); James Stephenson (Troy).

41 — Andy Hatton (Farmington); Tim Kennedy (Plymouth).

44 — Steve Chamberlain (Plymouth).

### PARENTS!

Call about our Junior Summer Program for children 9 yrs. old & up.

**Rose Shores Canton Racquetball, Inc.**

**REDUCED SUMMER RATES**  
**\$5<sup>00</sup>** per hour  
 6 am-4 pm weekdays

**\$8<sup>00</sup>** per hour  
 5 pm-10:30 pm weekdays  
 All Weekends & Holidays

**JUNE 1st-AUGUST 30**  
**NO COUPONS HONORED**

**16 AIR CONDITIONED RACQUETBALL/HANDBALL COURTS**  
**(MEETING ROOM • CONFERENCE ROOM)**

**41677 FORD RD. • CANTON**  
**PHONE - 981-3080**

**AIR CONDITIONED**  
 Discover the fun of Summer Racquetball



**NO MEMBERSHIP REQUIRED**



**AIR CONDITIONED**  
 Discover the fun of Summer Racquetball

### ADVERTISEMENT FOR BIDS

**Fellows Creek Drain Repairs**

**Charles N. Youngblood**  
 Wayne County Drain Commissioner

Sealed bids will be received by Charles N. Youngblood, Wayne County Drain Commissioner at 900 W. Lafayette, Detroit, Michigan 48226, until 2:00 P.M. Eastern Daylight Time, on Wednesday, July 30, 1980, at which time and place all bids will be publicly opened and read for repairs to the Fellows Creek Drain, north and south of Saltz Road in the Township of Canton, Wayne County, Michigan. This work consists essentially of earth work, and related repairs.

Plans and proposals are available at the Office of the Wayne County Drain Commissioner, 900 W. Lafayette, Detroit, Michigan after July 16, 1980. A deposit of Ten Dollars (\$10.00), check only, will be required for each set of plans and specifications furnished for prospective bidders. This deposit will be refunded upon the return in good order of all materials within fifteen (15) days after opening of bids.

A certified check, bank draft, or satisfactory bid bond, executed by the bidder and a surety company, payable to the Wayne County Drain Commissioner, in an amount equal to Five Percent (5%) of the bid shall be submitted with each bid.

The Wayne County Drain Commissioner reserves the right to reject any or all bids and to waive any irregularities in the bidding. Bids which have been submitted shall not be withdrawn after the time set for the opening of bids and shall remain firm for a period of one hundred eighty days after opening of bids.

**CHARLES N. YOUNGBLOOD**  
 Wayne County Drain Commissioner

Publish July 17, 1980

## LIVONIA BUILDING MATERIALS CO.

12770 Farmington Rd. S. of Schoolcraft Rd.  
**937-0478** **421-1170**

**SPECIAL DRYWALL SALE!**  
**FRIDAY, JULY 18 & SATURDAY, JULY 19**  
 1/2" OR 5/8" **\$2.75**

**DRYWALL 4x8 CASH AND CARRY ONLY**  
**ALL OTHER SIZES & THICKNESSES AT USUAL LOW PRICES**

**ALUMINUM CHIMNEY COVERS**  
 With Bird Guards

**IN STOCK 9"x9" 9"x13" 13"x13"**  
 OTHER SIZES AVAILABLE

**MON.-FRI. 8-5 SAT. 8-12**

**WHY PAY MORE WHEN THERE'S**  
**Wear Master!**  
**FREE BRAKE INSPECTION WITH THIS AD - \$10 OFF ON FULL BRAKE JOB**  
**MUFFLER & TAILPIPE** **\$48<sup>00</sup> INSTALLED** MOST U.S. CARS  
 — **LOW PRICES** —  
 FULL EXHAUST MOST FORDS AND CHEVYS \$105  
 SOME LATE MODEL GM CARS-EXHAUST (FROM CONVERTER BACK) \$75  
 REGULAR & HEAVY DUTY SHOCKS INSTALLED  
**CUSTOM PIPE BENDING • FOREIGN CAR SPECIALISTS**

**AAA WEAR MASTER** **422-5100**

32121 FORD RD., GARDEN CITY (2 blocks West of Merriman Rd.) **Monday-Friday 9 am - 6 pm**  
**Saturday 9 am - 5 pm**

**WAREHOUSE PLUS ONE CENT SALE**

**KEY KITCHENS**

**BRING IN YOUR MEASUREMENTS AND THIS AD FOR FREE DESIGN SERVICE**

**OUT THEY GO 75% OFF THESE ITEMS ONLY COME IN EARLY**

AUTUMN OAK			OLD HICKORY		
SIZE	LIST	SALE PRICE	SIZE	LIST	SALE PRICE
930 Wall	\$141.00	\$35.25	150 Wall	\$225.00	\$56.25
1230 Wall	\$150.00	\$37.50	2730 Wall	\$333.00	\$83.25
1830 Wall	\$161.00	\$40.25	3030 Wall	\$342.00	\$85.50
2130 Wall	\$173.00	\$43.25	3630 Wall	\$386.00	\$96.40
2730 Wall	\$217.00	\$54.25	4230 Wall	\$423.00	\$105.75
3330 Wall	\$241.00	\$60.25	B 18 Base	\$364.00	\$91.00
3630 Wall	\$259.00	\$64.75	B 27 Base	\$465.00	\$116.25
4230 Wall	\$292.00	\$73.00	B 30 Base	\$487.00	\$121.75
4830 Wall	\$325.00	\$81.25	B 36 Base	\$531.00	\$132.75
3324 Wall	\$220.00	\$55.00	DB 24 Drawer Base	\$557.00	\$139.25
3018 Wall	\$173.00	\$43.25	SRB 30 Sink Base	\$408.00	\$102.00
3618 Wall	\$198.00	\$49.50	SRB Sink Base	\$437.00	\$109.25
B 15 Base	\$225.00	\$56.25	CB 36 Corner Base	\$476.00	\$119.00
B 18 Base	\$238.00	\$59.50	BLS 36 Lazy Susan	\$609.00	\$152.25
B 21 Base	\$249.00	\$62.25	RF 30 Range Front	\$100.00	\$25.00
B 33 Base	\$233.00	\$58.25	VS 24 Vanity Sink	\$375.00	\$93.75
B 42 Base	\$378.00	\$94.50	VB 18 Vanity Base	\$319.00	\$79.75
B 48 Base	\$425.00	\$106.25	VKD 30 Knee Drawer	\$156.00	\$39.00
DB 15 Drawer Base	\$325.00	\$81.25			
DB 18 Drawer Base	\$341.00	\$85.25			
DB 21 Drawer Base	\$356.00	\$89.00			
DB 24 Drawer Base	\$378.00	\$94.00			

**HUNDREDS OF CABINETS IN STOCK & CARRY PLUS ONE CENT SALE**  
 WITH \$500.00 CABINET ORDER RECEIVE DELTA 100 FAUCET FOR ONE PENNY  
 WITH \$1000.00 CABINET ORDER RECEIVE STAINLESS STEEL SINK FOR ONE PENNY  
 WITH \$1500.00 CABINET ORDER RECEIVE 1/2 HORSEPOWER DISPOSAL MODEL JC 2004 FOR ONE PENNY  
 WITH \$2000.00 CABINET ORDER RECEIVE WHITE WESTINGHOUSE MODEL SU 200 DISHWASHER FOR ONE PENNY  
 WITH \$2500.00 CABINET ORDER RECEIVE ALL OF THE ABOVE FOR FIVE PENNIES  
 HOURS: MONDAY THROUGH FRIDAY 9-8 SATURDAY 9-6 SUNDAY 12-5

**FOR 1 CENT**

**KEY OF INDIANA AMISH CABINETS**  
**7 DAY SALE - JULY 17, 18, 19, 20, 21, 23, 24**

**60% OFF**  
 ON 12 DOORSTYLES  
 THE LARGEST SELECTION OF AMISH CABINETS IN MICHIGAN

**Bloomfield Hills Showroom**  
 1565 South Opdyke Rd.  
 338-1688 • 338-3088

**Dearborn Heights Showroom**  
 8262 North Telegraph  
 278-5333 • 278-0996

**ONE CENT SALE AT KEY KITCHENS**  
**BUY DIRECT - NO MIDDLEMAN MARK-UP!**  
**HURRY, SALE ENDS JULY 24**

**OASIS GOLF CENTER**  
**3 PUTT PRO SHOP**

**SUMMER CLEARANCE SALE**  
**FANTASTIC BARGAINS**

LADIES GOLF SKIRTS & TOPS  
Quantum, Evis, Etoria, Elaine-Benedict Sizes 6-20 SKIRTS from \$18.90 TOPS from \$9.80 **30% OFF**

**Dunlop X-OUTS** **\$6<sup>88</sup> dozen**

**TRADE - OLD PUTTER** **\$5<sup>00</sup> toward new one**

**\$2 Off all sweaters & jackets from \$12<sup>95</sup> - Leading Brands \$2**

**ONE OF A KIND SALE:** Reduced for Quick Sale

MacGregor VIP Woods - 4 Woods	\$129 <sup>95</sup>
Spalding Elite Woods - 3 Woods	\$139 <sup>95</sup>
Dunlop "Blue Max" Woods - 4 Woods	\$129 <sup>95</sup>
Browning Woods - 3 Woods	\$110 <sup>00</sup>
T. Penna Woods - 4 Woods Persimmon	\$179 <sup>95</sup>
Ram Accubar 4 Woods	\$149 <sup>95</sup>

**39500 FIVE MILE ROAD** **420-2228**  
(Between I-275 & Haggerty)  
**HOURS: 9 A.M. - 9 P.M.**

**Parts Plus autostore** **PROFESSIONAL PARTS PEOPLE**  
 "BRAND NAMES YOU CAN TRUST" **GOOD ONLY AS LONG AS SUPPLIES LAST**

**Valvoline** **PT #461**  
**OUTBOARD & 2 CYCLE OIL** **\$1<sup>27</sup> QT.**

**Air Conditioning Charge-It Kit** **\$5<sup>34</sup> PT #4000**  
 Includes Freon - 12  
 Refills..... \$1.29

**LAN-LIN HAND CLEANER** **PT #M10-66** **94¢**

**Curved Radiator Hose** **\$4<sup>47</sup>**  
 • factory formed to fit perfectly  
 • withstands higher engine temperatures  
**As Low As**

**CANTON AUTO PARTS**  
 5864 Sheldon Rd. Sheldon at Ford Rd.  
 Harvard Square Shopping Counter  
**459-7780 M - F 8-7 Sat 9-7 Sun 10-5**

# Convention sights and faces add luster to a gala affair



Michigan delegate Jerry Nissley raises his hands in approval as Gerald Ford took the podium to address the convention Monday night. (Staff photo by John Stano)



State Sen. Jack Welborn and delegate Peter Secchia have a little fun during a break in convention proceedings Tuesday. Both are with the Michigan delegation. (Staff photo by Randy Borst)



Cheerful delegates urged Gov. Ronald Reagan to pick New York Congressman Jack Kemp, former pro football quarterback, as his vice presidential running mate. (Staff photo by Randy Borst)

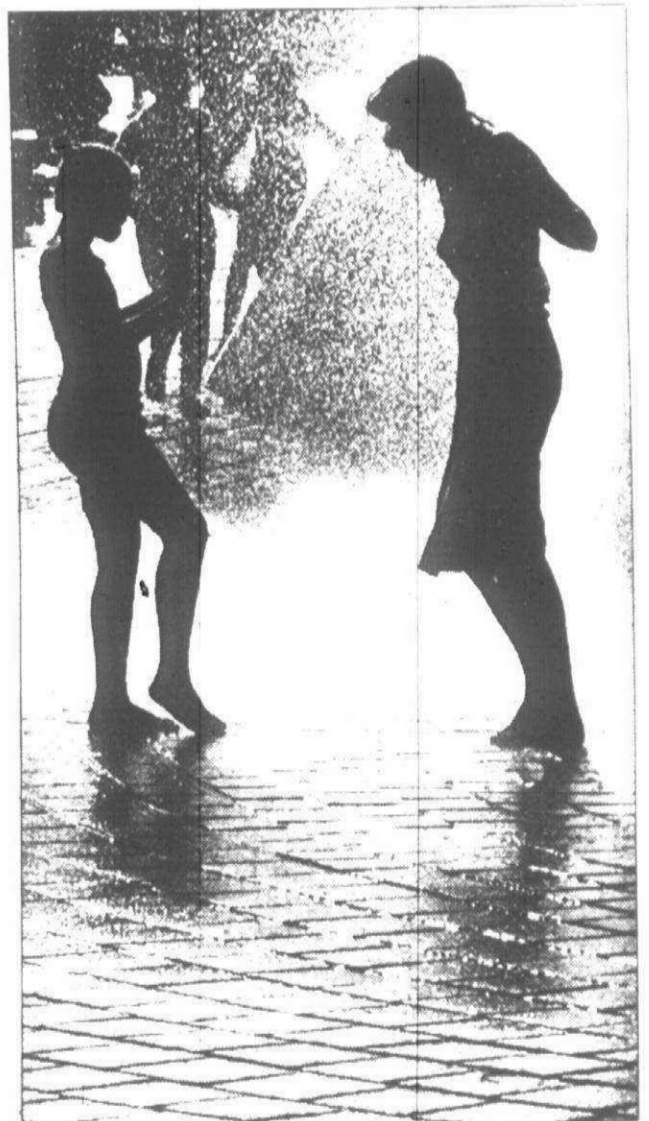

As the temperatures outside the Joe Louis Arena soared into the 90s during convention week, several visitors took advantage of the water fountain in Hart Plaza to cool off. (Staff photo by Randy Borst)



Nancy Reagan attended the convention sessions while her husband Ronald followed tradition and stayed away from the Joe Louis activities. (Staff photo by Art Emanuele)



Gov. William Milliken greeted Detroit Mayor Coleman Young with applause Monday during opening ceremonies as the mayor welcomed the GOP convention to Detroit. (Staff photo by David Frank)



Betty and Gerald Ford waved to the crowd from the podium Monday evening before Ford offered his

remarks on the future of the Republican party. (Staff photo by John Stano)

# House rejects \$100 million funding

Here's how area members of Congress were recorded on major roll call votes in the days leading up to the congressional recess that began July 3.

### HOUSE

**LEAA:** The House rejected 182-221 an amendment to spend \$100 million in fiscal 1981 on Law Enforcement Assistance Administration (LEAA) grants to states and localities. Critics say that historically LEAA grants have wasted taxpayers' money on police gadgetry while doing little to cut the crime rate. The vote came during debate on an appropriations bill later passed and sent to the White House.

Supporter Robert McClory, R-Ill., said "it is time to stop the slow but increasingly successful attempt to murder the LEAA."

Opponent Robert Giarmo, D-Conn., said "LEAA is a program that ought to be chopped, terminated, killed."

Members voting "nay" were opposed to any money in the bill going for LEAA grants to states and localities.

Reps. Carl Pursell, R-Plymouth; David Bonior, D-Mt. Clemens; William Brodhead, D-Detroit; James Blanchard, D-Pleasant Ridge; and William Broomfield, R-Birmingham voted "yea." Rep. William Ford, D-Taylor, voted "nay."

### SENATE

**COST-OF-LIVING HIKES:** By a vote of 30-59, the Senate killed an amendment requiring that civil service retirees get only one cost-of-living increase each year. This means there will be a continuation of the present system of two annual hikes in civil service pensions to keep pace with inflation. In fiscal 1981, there will be just one increase. The vote came during debate on a budget bill passed and sent to conference with the House.

Sen. Ernest Hollings, D-S.C., a supporter of a single hike, said "at a time when the average American family is hard put to make ends meet... there is simply no justice in singling out the civilian federal retiree for a special and unmatched privilege."

Sen. David Pryor, D-Ark., an opponent, said: We are talking about 1.6 million retired federal employees... and survivors of those employees who are actually going to get cut on the average of \$300 to \$400 a year" if the amendment becomes law.

Senators voting "yea" wanted civil service retirees to get one rather than two annual cost-of-living hikes. Democratic Sens. Donald Riegle and Carl Levin voted "nay."

**JOBLESS PAY:** The Senate rejected 27-60 an amendment that sought to make it easier for an individual to get extended unemployment benefits. Extended benefits are those paid for 13 weeks in high unemployment areas after the 26 weeks of regular jobless benefits run out.

The amendment sought to block legislation to deny extended benefits if the recipient has refused to accept a menial job. The vote came during debate on S 2885 (see preceding vote) which will impose the tougher eligibility requirement if it becomes law.

Supporter Riegle said, "The jobless workers in

Michigan and other states... need our help to tide them through this recession. This is no time to cut benefits."

Opponents of the amendment argued that a jobless person who has refused minimum wage work as "unsuitable" is undeserving of an additional 13 weeks of unemployment benefits.

Senators voting "nay" wanted to toughen eligibility requirements for extended unemployment compensation.

Levin voted "yea." Riegle did not vote.

**TAX INDEXING:** By a vote of 54-39, the Senate tabled and thus killed a proposal to adjust income tax rates, deductions and credits to account for inflation. Advocated say the plan would curb the "taxflation" that results when inflation eats away at real income gains by pushing salaries and wages into higher tax brackets. The vote came during de-

bate on a debt ceiling measure later given final congressional approval.

Sen. Daniel Moynihan, D-N.Y., a supporter of killing the plan, said tax-indexing has met with "near disastrous" results in Brazil, and "would be a declaration by this body that we do not expect ever to bring the rate of inflation down and take it out of our system."

Sen. William Armstrong, R-Colo., sponsor of the tax-indexing proposal, said: "The effect of taxflation is to transfer wealth from the productive private sector to the government, which produces only rhetoric, red tape and oceans of red ink."

Senators voting "nay" favored the tax-indexing amendment.

Levin and Riegle voted "yea."

## OUR LOW PRICES HELP YOU MAKE IT



<h3>ASPHALT SHINGLES</h3> <p>— MANUFACTURED TO NEW METRIC STANDARDS — SELF SEAL — 3 BDLS.—235# — 101 1/2 SQ. FT. — CLASS C, UL LABEL</p>  <p><b>\$732*</b> BDL.     <b>\$2196*</b> SQ.</p> <p>15# FELT — \$10<sup>65</sup> 90# ROLL ROOFING — \$11<sup>95</sup></p>	<h3>CDX SHEATHING PLYWOOD</h3> <p>4x8-3/8" <b>\$689*</b> 4x8-1/2" <b>\$799*</b></p> 	<h3>STUDS</h3> <p>CONSTRUCTION GRADE 2x4-7' <b>95¢*</b> 2x4-8' <b>\$119*</b> 2x4-10' <b>\$179*</b></p> <p>ECONOMY GRADE 2x4-7' <b>65¢*</b> 2x4-8' <b>79¢*</b></p>																																																																				
<h3>MAKE YOUR HOME A VACATION SPOT</h3> <p>WITH ERECTO-PAT DECK KITS AND PRESERVATIVE PRESSURE-TREATED LUMBER 10'x14' DECK <b>\$272<sup>99</sup></b> (INCLUDES NAILS, CEMENT &amp; HARDWARE)</p> <table border="1" data-bbox="492 1465 927 1674"> <tr><th></th><th>8'</th><th>10'</th><th>12'</th><th>14'</th><th>16'</th><th>18'</th><th>20'</th></tr> <tr><td>2x4</td><td>2.19</td><td>2.59</td><td>3.36</td><td>3.69</td><td>4.67</td><td>5.05</td><td>5.61</td></tr> <tr><td>2x6</td><td>2.99</td><td>3.85</td><td>5.16</td><td>5.72</td><td>7.59</td><td>9.07</td><td>10.70</td></tr> <tr><td>2x8</td><td>4.25</td><td>5.32</td><td>7.92</td><td>8.39</td><td>9.59</td><td>11.16</td><td>14.89</td></tr> <tr><td>2x10</td><td>5.34</td><td>6.87</td><td>9.90</td><td>12.25</td><td>13.99</td><td>14.88</td><td>16.53</td></tr> <tr><td>2x12</td><td>9.36</td><td>11.99</td><td>14.94</td><td>16.79</td><td>19.92</td><td>25.39</td><td>28.19</td></tr> <tr><td>4x4</td><td>4.79</td><td>6.73</td><td>8.07</td><td>9.42</td><td>10.76</td><td></td><td></td></tr> </table> 		8'	10'	12'	14'	16'	18'	20'	2x4	2.19	2.59	3.36	3.69	4.67	5.05	5.61	2x6	2.99	3.85	5.16	5.72	7.59	9.07	10.70	2x8	4.25	5.32	7.92	8.39	9.59	11.16	14.89	2x10	5.34	6.87	9.90	12.25	13.99	14.88	16.53	2x12	9.36	11.99	14.94	16.79	19.92	25.39	28.19	4x4	4.79	6.73	8.07	9.42	10.76			<h3>8 FT. PICNIC TABLE</h3> <p>HEAVY CONSTRUCTION WITH FRAME AND FIVE 2x10x8'</p> <p><b>\$44<sup>14</sup>*</b></p> 	<h3>DOUGLAS FIR PLYWOOD SIDING</h3> <p>5/8" THICK TEX. 1-11, 4", 8" O.C.</p> <p>4x8 — \$17.45 4x9 — \$21.60 4x10 — \$25.10</p> <p>REVERSE BD. &amp; BATTEN 4x8 — \$18.50 4x9 — \$22.90 4x10 — \$26.50</p>												
	8'	10'	12'	14'	16'	18'	20'																																																															
2x4	2.19	2.59	3.36	3.69	4.67	5.05	5.61																																																															
2x6	2.99	3.85	5.16	5.72	7.59	9.07	10.70																																																															
2x8	4.25	5.32	7.92	8.39	9.59	11.16	14.89																																																															
2x10	5.34	6.87	9.90	12.25	13.99	14.88	16.53																																																															
2x12	9.36	11.99	14.94	16.79	19.92	25.39	28.19																																																															
4x4	4.79	6.73	8.07	9.42	10.76																																																																	
<h3>SAVE!! INSULATE IN JULY</h3> <table border="1" data-bbox="492 1722 1178 2012"> <tr><th colspan="2">KRAFT FACED</th><th>SQ. FT.</th><th>ROLL</th></tr> <tr><td>3 1/2 x 15</td><td>— 88 SQ. FT.</td><td>11¢*</td><td>\$9<sup>68</sup>*</td></tr> <tr><td>3 1/2 x 23</td><td>— 135 SQ. FT.</td><td>11¢*</td><td>\$14<sup>85</sup>*</td></tr> <tr><td>6 x 15</td><td>— 49 SQ. FT.</td><td>19¢*</td><td>\$9<sup>31</sup>*</td></tr> <tr><td>6 x 23</td><td>— 75 SQ. FT.</td><td>19¢*</td><td>\$14<sup>25</sup>*</td></tr> <tr><th colspan="2">UNFACED</th><th>SQ. FT.</th><th>ROLL</th></tr> <tr><td>6 x 15</td><td>— 49 SQ. FT.</td><td>18¢*</td><td>\$8<sup>82</sup>*</td></tr> <tr><td>6 x 23</td><td>— 75 SQ. FT.</td><td>18¢*</td><td>\$13<sup>50</sup>*</td></tr> </table> 	KRAFT FACED		SQ. FT.	ROLL	3 1/2 x 15	— 88 SQ. FT.	11¢*	\$9 <sup>68</sup> *	3 1/2 x 23	— 135 SQ. FT.	11¢*	\$14 <sup>85</sup> *	6 x 15	— 49 SQ. FT.	19¢*	\$9 <sup>31</sup> *	6 x 23	— 75 SQ. FT.	19¢*	\$14 <sup>25</sup> *	UNFACED		SQ. FT.	ROLL	6 x 15	— 49 SQ. FT.	18¢*	\$8 <sup>82</sup> *	6 x 23	— 75 SQ. FT.	18¢*	\$13 <sup>50</sup> *	<h3>ARMSTRONG SUSPENDED CEILINGS</h3> <p>2'x4' GRENOBLE</p> <p><b>\$179*</b> EA.</p> 	<h3>SUSPENDED CEILING GRID</h3> <p>2' CROSS TEE — 42¢ 4' CROSS TEE — 79¢ 10' WALL ANGLE — \$1<sup>45</sup> 12' MAIN RUNNER — \$2<sup>29</sup></p> <p>LIGHT FIXTURES 2 LAMP — \$14<sup>25</sup> 4 LAMP — \$22<sup>85</sup> (BULBS NOT INCLUDED)</p>																																				
KRAFT FACED		SQ. FT.	ROLL																																																																			
3 1/2 x 15	— 88 SQ. FT.	11¢*	\$9 <sup>68</sup> *																																																																			
3 1/2 x 23	— 135 SQ. FT.	11¢*	\$14 <sup>85</sup> *																																																																			
6 x 15	— 49 SQ. FT.	19¢*	\$9 <sup>31</sup> *																																																																			
6 x 23	— 75 SQ. FT.	19¢*	\$14 <sup>25</sup> *																																																																			
UNFACED		SQ. FT.	ROLL																																																																			
6 x 15	— 49 SQ. FT.	18¢*	\$8 <sup>82</sup> *																																																																			
6 x 23	— 75 SQ. FT.	18¢*	\$13 <sup>50</sup> *																																																																			
<h3>SPRUCE STOCKADE FENCE</h3> <p>#1 GRADE</p> <p><b>\$18<sup>95</sup>*</b></p> <p>8'x6' PANEL</p> 	<h3>DRYWALL</h3> <p>4x8-3/8" — \$274* 4x8-1/2" — \$279*</p> <p>JOINT COMPOUND GAL. — \$3<sup>19</sup>*</p> <p>5 GAL. <b>\$7<sup>95</sup>*</b></p> 	<h3>PIPING HOT PRICES</h3> <p>PVC PIPE 1 1/2" x 10' — \$47<sup>2</sup> 2" x 10' — \$64<sup>2</sup> 3" x 10' — \$12<sup>93</sup> 4" x 10' — \$18<sup>37</sup></p> <p>COPPER PIPE 1/2" x 10' — \$4<sup>98</sup> 3/4" x 10' — \$7<sup>95</sup></p>																																																																				
<h3>CONSTRUCTION LUMBER</h3> <table border="1" data-bbox="492 2398 1178 2688"> <tr><th></th><th></th><th>8'</th><th>10'</th><th>12'</th><th>14'</th><th>16'</th><th>18'</th><th>20'</th></tr> <tr><td rowspan="2">SPF</td><td>2x4</td><td>1.19*</td><td>1.79*</td><td>2.19*</td><td>2.39*</td><td>2.99*</td><td>3.87</td><td>4.49</td></tr> <tr><td>2x6</td><td>2.39*</td><td>2.49*</td><td>3.69*</td><td>3.99*</td><td>4.89*</td><td>5.89</td><td>6.59</td></tr> <tr><td rowspan="2">SOU PINE</td><td>2x8</td><td>3.14</td><td>3.95</td><td>5.69</td><td>5.93</td><td>6.89</td><td>7.69</td><td>10.89</td></tr> <tr><td>2x10</td><td>3.91</td><td>4.89</td><td>7.23</td><td>8.64</td><td>9.74</td><td>9.96</td><td>11.10</td></tr> <tr><td rowspan="2">SOU PINE</td><td>2x12</td><td>6.76</td><td>8.45</td><td>10.45</td><td>11.83</td><td>13.93</td><td>16.76</td><td>18.63</td></tr> </table> 			8'	10'	12'	14'	16'	18'	20'	SPF	2x4	1.19*	1.79*	2.19*	2.39*	2.99*	3.87	4.49	2x6	2.39*	2.49*	3.69*	3.99*	4.89*	5.89	6.59	SOU PINE	2x8	3.14	3.95	5.69	5.93	6.89	7.69	10.89	2x10	3.91	4.89	7.23	8.64	9.74	9.96	11.10	SOU PINE	2x12	6.76	8.45	10.45	11.83	13.93	16.76	18.63	<h3>NO. 2/STANDARD WHITEWOODS</h3> <table border="1" data-bbox="1217 2398 1487 2688"> <tr><th>REG.</th><th>SALE</th></tr> <tr><td>1x2 — 10'</td><td>LIN. 9¢</td></tr> <tr><td>1x3 — 14'</td><td>LIN. 13¢</td></tr> <tr><td>1x4 — 16'</td><td>LIN. 15¢</td></tr> <tr><td>1x6 — 25'</td><td>LIN. 23¢</td></tr> <tr><td>1x8 — 31'</td><td>LIN. 29¢</td></tr> <tr><td>1x10 — 42'</td><td>LIN. 39¢</td></tr> <tr><td>1x12 — 68'</td><td>LIN. 52¢</td></tr> </table>	REG.	SALE	1x2 — 10'	LIN. 9¢	1x3 — 14'	LIN. 13¢	1x4 — 16'	LIN. 15¢	1x6 — 25'	LIN. 23¢	1x8 — 31'	LIN. 29¢	1x10 — 42'	LIN. 39¢	1x12 — 68'	LIN. 52¢	<h3>FIR PLYWOOD</h3> <p>GOOD ONE SIDE EXTERIOR GRADE</p> <p>4x8-1/4" — \$9<sup>89</sup> 4x8-3/8" — \$13<sup>10</sup> 4x8-1/2" — \$14<sup>60</sup> 4x8-5/8" — \$17<sup>85</sup> 4x8-3/4" — \$20<sup>17</sup></p> 
		8'	10'	12'	14'	16'	18'	20'																																																														
SPF	2x4	1.19*	1.79*	2.19*	2.39*	2.99*	3.87	4.49																																																														
	2x6	2.39*	2.49*	3.69*	3.99*	4.89*	5.89	6.59																																																														
SOU PINE	2x8	3.14	3.95	5.69	5.93	6.89	7.69	10.89																																																														
	2x10	3.91	4.89	7.23	8.64	9.74	9.96	11.10																																																														
SOU PINE	2x12	6.76	8.45	10.45	11.83	13.93	16.76	18.63																																																														
	REG.	SALE																																																																				
1x2 — 10'	LIN. 9¢																																																																					
1x3 — 14'	LIN. 13¢																																																																					
1x4 — 16'	LIN. 15¢																																																																					
1x6 — 25'	LIN. 23¢																																																																					
1x8 — 31'	LIN. 29¢																																																																					
1x10 — 42'	LIN. 39¢																																																																					
1x12 — 68'	LIN. 52¢																																																																					



NICK FELDMAN

## Crusty cyclist thanks GOP

"A Thank You GOP From A Democrat," read the lettered sign sandwiching 74-year-old cyclist Nick Feldman.

Feldman, of Detroit, sat outside Cobo Hall entering with reporters and passersby aboard his Paramount racing bike. He and Eddie Jones Jr. were riding around the convention center demonstrating their pride in the presence of the Republicans.

"This is really a shot in the arm for the city," said Feldman, who said he bikes 5,000 miles per year. "It's really bringing in the bucks, and that means a lot of people are working who wouldn't be otherwise."

A retired Chrysler worker, Feldman said he might break a 40-year allegiance to the Democratic party by voting for Reagan.

Reagan's age (69) certainly isn't a deterrent for Feldman. "I'm only four years older than he is and I'm still going strong," he said.

Still, Feldman cut quite a different figure with his long gray beard and flowing gray hair than Reagan — dark-haired, clean-cut and usually wearing a business suit.

## PINE CASHWAY LUMBER

*Our low prices help you make it.*

<b>MT. CLEMENS</b> 5 S. GROESBECK South of Cass Ave. 469-2300	<b>UTICA</b> 48075 VAN DYKE Bet. 21 Mile & 22 Mile 739-7463	<b>WEST SIDE</b> 12222 INKSTER RD. Bet. Plymouth & Schoolcraft 937-9111	<b>LINCOLN PARK</b> 3255 FORT ST. Bet. Southfield & Goddard 386-5177	<b>FENTON</b> 14375 TORREY RD. Torrey & S. Long Lake Rd. 629-3300
<b>DETROIT</b> 5311 E. NEVADA Bet. Ryan & Mound 368-1800	<b>YPSILANTI</b> 629 N. HURON 481-1500	<b>WATERFORD TWP.</b> 7374 HIGHLAND RD. On M-59 Bet. Airport & Williams Lake Rd. 666-2450	<b>BRIGHTON</b> 525 MAIN ST. 1 Bld. W. of Grand River 227-1831	<b>SOUTHFIELD</b> 22800 W. 8 MILE 1 Mile E. of Telegraph 353-2570

OPEN: Mon. through Thurs. 8 am-6 pm  
Friday 8 am-8 pm  
Sat. 8 am-5 pm; Sun. 10 am-4 pm

Some items may not be available at all locations  
All items Cash & Carry - Sale items marked with  
Prices Good July 17-20



Thursday, July 17, 1980

## upcoming things to do

**EARL** Klugh and his sextet play jazz Friday through Sunday at Baker's Keyboard Lounge, Livernois at Eight Mile in Detroit. For more info, call 864-1200.

"**ATMOS**," the film exploring whether the world is entering another ice age, continues its run at the Detroit Science Center. Showings are about once an hour at the center. John R at Warren in the Cultural Center. Museum hours are 9 a.m. to 4 p.m. Tuesday-Friday, 10 a.m. to 5 p.m. Saturday, and noon to 5 p.m. Sunday, with evening hours 7-9:30 p.m. Friday-Sunday. Admission is \$1.50.

**PAUL** Webb's band will play country-western music 1-7 p.m. today through Saturday on the stage near the fountain at Livonia Mall, Seven Mile and Middlebelt.

**WYANDOTTE** has its annual street art fair and sidewalk sale 9:30 a.m. to 10 p.m. today through Saturday on Biddle Avenue. Over 300 artists and craftsmen will be on hand, and musical groups will perform at various times throughout the proceedings.

**ROYAL** Oak is also having its annual outdoor art fair, 11 a.m. to 6 p.m. Saturday and Sunday in Memorial Park, Woodward at 13 Mile Road. The juried show has 88 artists in a variety of media.

**LYMAN** Woodard Organization gives a benefit concert for the Detroit Waldorf School at 8 p.m. Monday at Cafe Harmonie, 1435 Randolph in downtown Detroit. Admission is \$5 at the door. Mary Roberts and the Inside/Outside Band will give a similar show at 8 p.m. Tuesday for \$3.50.

**NIGHTCAP** with Mozart has its first anniversary celebration Friday, with birthday cookies and a chamber quartet performing Mozart's "Nachtmusik" at 11 p.m. at the Birmingham Unitarian Church, 651 Woodward at Lone Pine Road. Admission is \$5 (\$3 for students). For more info, call 851-8934.

## Attic opens new drama next week

The Attic Theatre will open "The Sea Horse" by Edward J. Moore on July 25.

Set in a West Coast waterfront bar, the play is about Harry Bales, a seaman who, when on shore leave, usually heads for The Sea Horse, a bar run by Gertrude Blum, thick-shelled proprietor.

The play will be performed at 6 and 9 p.m. Saturdays, and at 8 p.m. Thursdays, Fridays and Sundays through Sept. 13.

The plot revolves around the ritual dance of courtship, as the two outwardly abrasive characters fight, make up, fight again, spin dreams and deflate them, make love and reveal their long locked-up secrets.

The production will be directed by Robert LeVoyd-Wright, a featured company member in the Attic's productions of "A Midsummer Night's Dream" and "Bloody Bess."

The role of Gertrude Blum will be portrayed by Nora Chester and the part of Harry Bales will be performed by Martin Laplatney, who directed "Bloody Bess" at the Attic last spring.

The Attic is at 525 E. Lafayette in Detroit's Greektown district. For reservations, call 963-7789.



The streets of Ann Arbor host one of the largest arts and crafts fairs anywhere each summer.

## Art fair opens Wednesday in Ann Arbor

The 10th annual Ann Arbor Art Fair, traditionally one of the largest in the state, will take place Wednesday through July 26.

The campus section of the University Artists and Craftsmen Guild has moved to a new site in front of the Michigan Union. The Main Street fair will remain in the heart of Ann Arbor.

Hours will be from 10 a.m. to 10 p.m. Wednesday through Friday, and 10 a.m. to 6 p.m. Saturday.

Plan on using M-14 from the north (M-14 leads directly to the Main Street fair) or the Ann Arbor-Saline Road exit off I-94 from the south to find fair parking. Pioneer High School offers parking and shuttle service one mile from the Ann Arbor-Saline Road. Additional parking will be available on both sides of town with shuttle bus service to and from the fair sites.

Banners flying atop booths will identify the type of art or craftware sold in the booths. Guild artists will exhibit original handcrafted work ranging from furniture and paintings to ceramics and jewelry.

Most of the previous fair artists will be located on State Street between Williams and the Michigan Union. This site may be a good place to rendezvous with out-of-town friends or enjoy an air-conditioned respite from the July heat.

Evening events are scheduled throughout the Union, and during the day the Union Gallery will be open to serve food and refreshments.



### Tex

Tex Beneke and his band play big band music for dancing at 7 p.m. Sunday in the outdoor dance center of Willow Metropark near New Boston. Admission is free after the regular park admission (\$2 daily). For more info, call 654-6287.



### Bobo

Blues singer Bobo Jenkins, founder of the Detroit Blues Club, performs in the Music Under the Stars series at 8:30 p.m. Wednesday in Livonia's Civic Center Park at Farmington Road and Five Mile. Admission is free.



### Roni

Banjo player and comedian Roni Stoneman, known for her part in the "Hee Haw" TV series, performs free at 11 a.m., 2 and 7 p.m. Saturday in the central court of Westland Center, Warren at Wayne Road in Westland.

**STREET'S PUB**  
NOW IN CANTON  
HAPPY HOUR 4-6 P.M.  
• SOUP • SALAD BAR  
• SANDWICHES • COCKTAILS  
LOCATED IN THE REAR OF THE PALACE RESTAURANT FORD ROAD AT I-275

**NOW OPEN**  
**O'Sheehan's**  
A COCKTAIL LOUNGE  
NORTHVILLE'S NEWEST ADULT FUN SPOT  
A NEW COCKTAIL LOUNGE EXPERIENCE  
Cocktail Hour 4 P.M. to 6 P.M.  
\$1.00 OFF All Cocktails  
FREE Snacks  
EXCITING ICE CREAM COCKTAILS  
MAGNIFICENT MUNCHIES  
FABULOUS BAR B.Q. SPARE RIBS  
OUR FAMOUS "SHEEHAN BURGERS"  
PLUS OTHER SANDWICH GREATS  
OPEN DAILY AT 11 A.M.  
LUNCH, DINNER OR LATE SNACKS

**O'Sheehan's** A COCKTAIL LOUNGE  
Side entrance at Little Caesar's Pizzeria  
43333 Seven Mile Rd., Northville 348-2440

**The Lion and the SWORD**  
31410 Ford Rd. Garden City  
(corner at Merriman) 427-9075  
TRY OUR DINNER SPECIALS  
• Prime Rib ..... \$6.95  
• T-Bone ..... \$6.95  
LUNCHEON SPECIAL ..... \$3.95

Appearing Thursday thru Saturday  
**GALAXY**  
**NEW DINNER SPECIALS**  
Broiled Pork Chop, Potato & Vegetable  
Rib Eye Steak, Potato & Vegetable  
Veal Parmesan, Spaghetti & Vegetable  
Roast Sirloin of Beef, Potato & Vegetable  
Fish & Chips or Deep Fried Chicken, Cole Slaw & Potato  
Chicken Cordon Bleu, Veal Cordon Bleu, Potato & Vegetable  
**\$3.95**  
COCKTAIL HOURS: 11-12 a.m. & 4-6:30 p.m.  
BUSINESSMEN'S LUNCH - DINING  
DANCING - BANQUET FACILITIES  
Open 11 a.m. - 2:30 a.m. Mon.-SAT.

**Huck's**  
Welcome **GOP'S**  
This Week  
CONVENTION SPECIALS  
Thurs., Fri., Sat.  
Celebrate Republican  
**5.95**  
Convention With Us  
Prime Rib Crab Legs N.Y. Strip  
BEAUTIFUL BANQUET FACILITIES AVAILABLE FOR ALL OCCASIONS  
5 Mile & Inkster • 535-3200

**Farwell & Friends**  
8051 Middlebelt  
Bet. Joy Rd. and Ann Arbor Trail  
Banquet Facilities Available  
Call 421-6990  
**FRIDAY SPECIAL**  
FISH & CHIPS \$3.95  
DINNER  
Farwell's Fare of the Week  
Monday - Saturday  
New York Strip Steak \$5.95  
Prime Rib \$6.95  
King Crab Legs \$6.95  
Lobster Tail \$7.95  
Sunday Special \$3.95  
Chicken Dinner (all dinners include Salad, Potato and Loaf of Homemade Bread)  
"And the Ladies"  
Tuesday - Ladies Night  
All Ladies dinners 1/2 price  
-Dinner specials not included-  
Now Appearing  
**"LOST & FOUND"**  
Fri., Sat., Sun.  
All Major Credit Cards honored.  
Open: Mon.-Sat. 3 p.m.-2 a.m.  
Sunday 2 p.m.-2 a.m.

**ART AUCTION**  
at  
**Gallery Art Center**  
OPEN TO THE PUBLIC  
Free Admission • Refreshments  
FREE PRINT WITH PURCHASE  
Sunday Afternoon July 20, 1980  
Preview Showing 1:00 p.m. to 2 p.m.  
Auction Begins at 2:00 p.m.  
UNBELIEVABLE PRICES  
Oils • Lithos • Etchings  
Serigraphs • Batik  
Featuring: Alvar, Agam, Appel, Boulanger, Louis, Bertrand, Bomberger, Calder, Chagall, Delacroix, Dali, Timberlake, Friedlander, Edna Hibel, Jablonsky, LaLande, Aldo Luongo, Lebandang, Joan Miro, Charlene Mitchell, Neiman, Niernan, Rockwell, Schary, Simbari, Vassarely, Mary Vickers, Moore and many more.  
**GALLERY ART CENTER**  
18831 W. 12 Mile just W. of Southfield Rd.  
Lathrup Village 557-0595  
MasterCharge•Visa•Cash•Checks Accepted

JOHN YOUR HOSTS CHRIS  
**Johnny K's**  
(formerly JP's)  
• Lunches • Dinners  
• Cocktails  
SPECIALS  
Wednesday SPAGHETTI with Salad All You Can Eat \$2.95  
Friday FISH & CHIPS All You Can Eat \$4.95  
Try Our Famous WET BURRITO Dancing • Entertainment Tuesday thru Saturday  
FREE CARICATURES Every Tuesday 9 P.M. - Midnight by Check  
"Crystal Blue" appearing Mon. July 21 Only 9 P.M. - Midnight For your listening and dancing pleasure. All Cocktails @ Day Prices  
32826 W. Five Mile Rd. (East of Farmington Rd.)  
Livonia 425-8530

WHERE CAN YOU GO ON  
SUNDAY NIGHT FOR ENTERTAINMENT?  
**PLUMS**  
SUNDAY, JULY 20, DANCING WITH  
**PATRICK J. OMARA**  
UNTIL 2:00 A.M. NO COVER  
30375 PLYMOUTH RD., BET. MIDDLEBELT & MERRIMAN  
NEXT TO THE HOLIDAY INN OF LIVONIA

**Muscular Dystrophy COUNTRY JAMBOREE**  
SUNDAY  
JULY 20 - 2 p.m. - 2 a.m.  
★ 12 hours of continuous live country music  
Cover Charge: \$1.00  
**Featuring:**  
JACK MOLETTE and the BORDERLINE EXPRESS with MARSHA DEE, Vocalist  
Plus all the Top Country Western bands in the area  
**TUESDAY - Country Hoe Down WEDNESDAY - Reduced Price for Ladies Drinks**  
43711 MICHIGAN AVE., 1 Mile West of I-275 CANTON 397-1988  
CORRAL HOUR Tues.-Fri. 3:30-6:30 reduced prices on drinks



**backgammon**  
**Michael Klolan**  
 of the American Backgammon Club

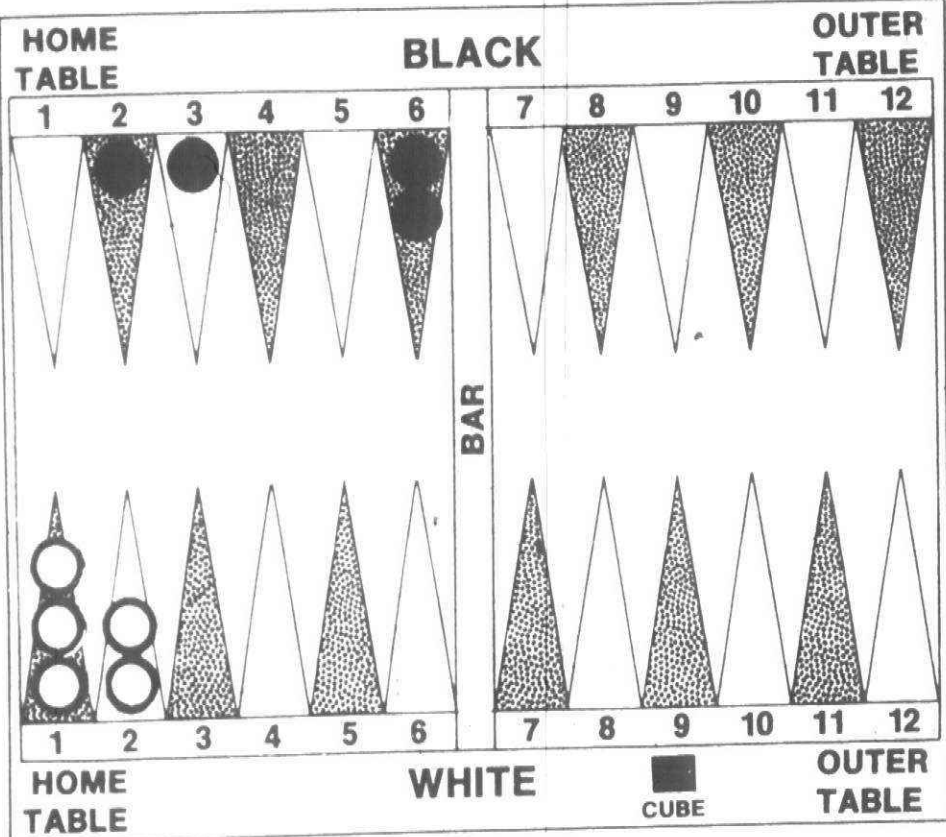

**MORE FROM THE PLIMPTON CUP COMPETITION IN LAS VEGAS**

During the finals match between Wayne Drogseth and Russell Sands, this position occurred. The score at this point is 8-2 in a 19-point final with Sands in the lead and Drogseth desperately fighting back.

Having a substantial lead in this game, Drogseth (black) doubled the cube to 2 shortly before he began bearing off. Sands (white) accepted and now owns the cube.

It is Sands' turn. Before rolling the dice, he redoubled the cube to 4, passing it to Drogseth. Should Drogseth accept?

White needs three rolls (excepting doubles) to complete the bear-off, and having all his checkers near the 1 point means he can't miss. It was a timely redouble.

Black would need two perfect rolls (barring double 6s, 5s, 4s and 3s — four chances out of 36) to beat white. Also,

the chances of his missing one checker bearing off are too great. So he will also need three rolls, minimum, and he is not on roll. He is certainly not the favorite.

Black is forced to pass the redouble and take a two-point loss.

During the time of bear-off, the use of the doubling cube is predominate. Often times, in tournament play, where each point brings you closer or further from victory, the cube is frequently used.

However, a player may take a risky double as they begin to bear off, knowing that if one nice set of doubles are rolled he could steal the lead and redouble his opponent out of the game.

Before you ever consider accepting the doubling cube, you must always consider the position of the checkers.

For more information on the game, contact the American Backgammon Club at Box 599, Plymouth 48170, or call 459-5776.



**second runs**  
**Tom Panzenhagen**

**\* OFF TV**

**"The Cure," 8 p.m. Saturday at the Redford Theatre, 17340 Lahser, phone 537-1133, \$3.**

"The Cure" is a silent Charlie Chaplin film of comparatively little note from the 1920s, but we list it here because it's about time we reminded you of the full program offered by the Redford Theatre.

Whenever the Redford schedules a film — two or three times a month — the film itself is only half the show. The other half is a sing-along pipe organ performance led by organist Bob Richards.

Authentic 1920s song slides and a 1928 Barton organ make for an evening of live entertainment and classic film in the 52-year-old, Japanese-styled theatre. Organ recitals begin at 7:30 p.m.

**nally 97 minutes.**

Not to be confused with "Angels Wash Their Faces" made in 1939 and starring Ronald Reagan, "Dirty Faces" is the classic tale of brothers (James Cagney and Pat O'Brien), one of whom grows up to be a hoodlum and the other a priest. Guess which one is which. Also starring Ann Sheridan, Humphrey Bogart and the original Dead End Kids.

**"The Terror" (1963), 12:45 Friday night on Channel 7. Originally 81 minutes.**

Jack Nicholson fans, take note. Here's your boy 17 years ago in a very bad monster movie that co-stars Boris Karloff. The question is: Is Jack a better actor today in "The Shining," or is still making all the same old faces?

**"Julia" (1977), 10 a.m. Tuesday at the Livonia Mall Cinema, Seven Mile at Middlebelt, phone 476-1166, free.**

Here's a deal that's hard to refuse — a program of free films at the mall. This week's fare is "Julia," a pretty good flick that's about — at least in part — the interesting relationship between writers Lillian Hellman and Dashiell Hammett.

The storyline goes well beyond that, though, getting more and more muddled as it does. Vanessa Redgrave, Jane Fonda and Jason Robards star.

**\* ON TV**

**"On the Waterfront" (1954), 8 p.m. Thursday on Channel 50. Originally 108 minutes.**

Union problems — a topical subject — are the focus for this fine Elia Kazan film that stars Marlon Brando, Karl Malden, Eva Marie Saint, Lee J. Cobb and Rod Steiger. Brando's at his peak in his "I coulda been a contender" scene.

**"Ali the Fighter" (1975), 8:30 a.m. Friday on Channel 20. Originally 90 minutes.**

And speaking of contenders, try this for a change of pace — a documentary of the first Muhammad Ali-Joe Frazier fight. And the winner is... aw, why spoil the drama.

**"The Candidate" (1972) followed by "The Best Man" (1964), starting at 11:30 Saturday on Channel 7. Originally 109 and 102 minutes, respectively.**

A couple of dandies for this very political time of the year, starting with Robert Redford as the candidate for the U.S. Senate. Some say the movie was based on the campaign of one-time California senator John Tunney. But look for a lot of Jerry Brown in there, as well, even though this picture was made before he became governor of that state. Peter Boyle co-stars as the compromising campaign director in this insightful look at modern-day politicking.

And then there's Oval Office-aspirant Henry Fonda, looking more presidential than nominee Reagan ever could. Sure, he looks the part, but is he really the best man for the job — Henry Fonda, that is? A gripping, tense film from the play by Gore Vidal.

**"To Kill a Mockingbird" (1962). Part I at 1 p.m. Monday and Part II and 1 p.m. Tuesday on Channel 50. Originally 129 minutes.**

Gregory Peck won an Oscar for his portrayal of a southern lawyer defending a black man accused of rape, but the focus is really on youngsters Mary Badham, Philip Alford and John Megna. The Robert Mulligan film masterfully adopts the children's point of view — both from stylistic and thematic standpoints. Also starring Brook Peters and Robert Duvall, in one of his first roles.

**BAY VALLEY MINI-VACATION PLANS**  
 "Living Your Way"  
 Recreation Golf Tennis  
**The Mini-Vacation • Golf Get-A-Way • Tennis Retreat**  
 Weekend, Weekday and Holiday Packages include Deluxe Parkside Room, Cheese and Sausage Board, Asti Spumante, Dinner, Brunchon, Wine, Cocktails, Lunches, and recreation. 18-hole championship Golf Links, in-door, out-door Tennis. Bikes and bike trails. Swimming in or out-doors, fine food Pier 19, Main Dining Room of the "Inn With Country Charm"

**You're only 1-1/2-hours away from the Bay Valley Inn — 1-75 at M-84 near Bay City —**

**Bay Valley Inn**  
 2470 Old Bridge Rd.  
 Bay City, MI 48706  
 517 686-3500

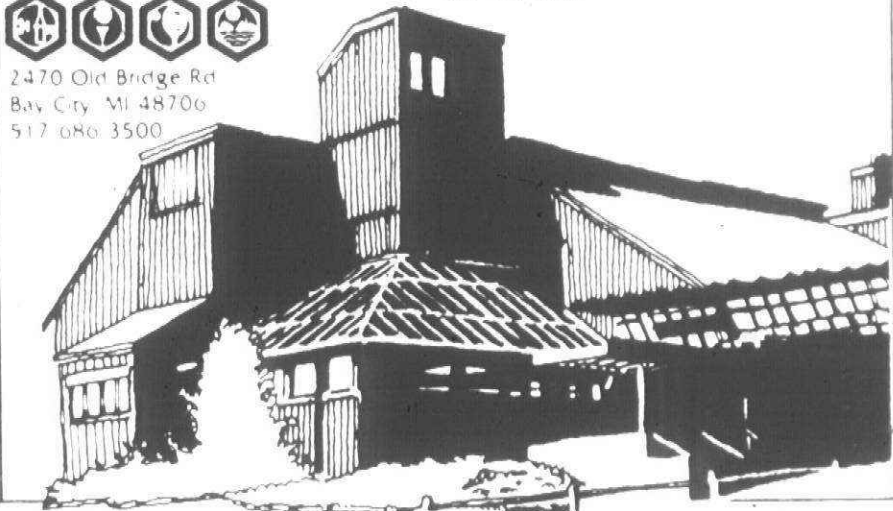

**Weekend Oasis**

There's an island of calm, away from summer's steamy bustle, where you'll enjoy a summer weekend just the way you want it... at the Bristol Place.

For \$45 per night (Canadian funds) enjoy 2 nights' deluxe accommodation, with children under 18 sharing their parents' room at no extra cost. Spend a cool weekend around our pool and outdoor patio. Enjoy our sauna and health club. And complimentary admission to our nightspot, Dr. Livingstone's.

For the children, there's a fully equipped playground, and baby sitting available.

Come in any 2 nights on a Friday, Saturday or Sunday. The parking's free. We have 24-hour room service, and in-room movies for a nominal charge.

Your perfect summer basis... the Bristol Place.

**The Bristol Place Hotel**  
 Affiliated with Sutton Place Hotel

950 DIXON RD., TORONTO, CANADA 675-9444 • WATS LINE (CANADA ONLY) (800) 268-4927  
 U.S. (800) 828-7491 N.Y. STATE ONLY (800) 462-7330  
 or see your travel agent

**WING YEE'S**  
**CANTONESE AND AMERICAN CUISINE**  
 • CARRY OUT SERVICE  
 • BANQUET ROOM AVAILABLE  
 • COCKTAILS • FAMILY DINNERS

**Try Our COMBINATION LUNCHEON SPECIAL**  
**Monday-Saturday, 11 a.m. - 4 p.m.**

37097 6 MILE RD., LIVONIA  
 NEWBURGH PLAZA  
 591-1901



**"Angels with Dirty Faces" (1938), 1 p.m. Friday on Channel 50. Originally 97 minutes.**

**GIGANTIC SUMMER ART FAIR**

FINAL CLEARANCE ON  
 1000'S OF GALLERY QUALITY ORIGINAL OIL PAINTINGS!  
 VALUES NEVER TO BE OFFERED AGAIN

**FRAMES 8x10 ORIGINAL OIL PAINTINGS \$12.95**

PROMINENT ARTISTS SUCH AS: MEDINA - HARGROVE BERTH - OVERMYER PLUS MANY MORE

**THIS SUNDAY ONLY 10 AM to 5 PM**

**PLYMOUTH HILTON 5 Mile & Northville Rd. PLYMOUTH**



We Serve **PIZZA**  
 Monday - Saturday 'til 2 a.m.  
**COCKTAIL HOUR**  
 3-6 p.m. Monday-Friday

**CORSI'S FAMILY RESTAURANT**  
 RESTAURANT AND COCKTAIL LOUNGE

**BANQUET FACILITIES**  
 • Weddings • Sport Banquets  
 • Any Occasion  
 up to 300 people  
 We Cater to all occasions

**WEEKLY DINNER SPECIALS 5 P.M. TO 10 P.M.**

Monday	Spaghetti with meat sauce	\$2.75
Tuesday	Baked Lasagna	\$3.75
Wednesday	Mostaccioli with meat sauce	\$2.95
Thursday	Chicken with fries	\$2.95
Friday	Broiled Lake Trout with Fries	\$4.25
Saturday	Egg Plant Parmisano	\$3.99
Sunday	Roast Beef with Mashed Potatoes	\$3.99

ALL DINNERS INCLUDE SOUP, SALAD, GARLIC ROLLS AND BUTTER  
 Private Room Available For Parties or Meetings  
 Call for Information  
 27910 W. 7 Mile, LIVONIA (Between Middlebelt and Inkster) **531-4960**

CREATIVE THEATRE INTERNATIONAL PRESENTS

**GINGER ROGERS & SID CAESAR**  
 IN  
**ANYTHING GOES**

Book by GUY BOLTON, P.G. WODEHOUSE, HOWARD LINDSAY AND RUSSELL CROUSE



**NOW THROUGH SUNDAY GOOD SEATS STILL AVAILABLE**  
 Tues-Sat 8:30 pm • 2 pm Wed & Sat • Sun 7 pm

**TICKETS BY PHONE: 963-7680**  
 or at all CTC Outlets

**MUSIC HALL CENTER 350 Madison-Detroit**  
 Group Rates 963-7622

**What you and your family can do any day at our Old Time Summer Festival**



- Ride an antique steam train
- Take a carriage or wagon ride
- Ride a Model-T
- Ride the old paddle-wheel Suwanee steamboat
- Take a raft to Suwanee Island
- Picnic in the Suwanee Island woods
- Hear a band concert
- Ride a turn-of-the-century Merry-Go-Round
- Horse around in the Penny Arcade
- Watch Doc Bryson Medicine Show
- Visit Menlo Park Compound—see where the light bulb was invented
- Watch many old-time crafts
- Dialogue with Ben Franklin
- See sheep, roosters, hens, ducks, geese, horses
- Browse in homes of Great Americans
- Look into factories of a hundred years ago
- See old-time movies in The Town Hall
- Hear strolling minstrels
- Hear Concert Saloon Music
- Meet with the Wright Brothers
- If the weather turns, visit Henry Ford Museum right next door
- Walk shady Village streets with ghosts of long ago
- 2 1/2 Hour General Information Party

Line-271-1976

**OLD TIME SUMMER FESTIVAL**

All Summer Long At  
**Greenfield Village & Henry Ford Museum**  
 Dearborn, Michigan

**THE GREAT RAM SPIRITS**

**Rib STEAK 3.89**  
 wild rice or potato salad, salt bread

**Lasagna 3.69**  
 salad salt bread

**Prime Rib 6.95**  
 potato salad salt bread

served anytime  
 7020 Wayne Rd.  
 at Warren Ave.  
 South of Westland Shopping Center



Mon. Tues. Wed. Thurs. 11am-11pm • Fri. Sat. 11am-1am • Sun. 3-11pm

### upcoming things to do

**ETHNIC** festivals continue at Hart Plaza on the riverfront in downtown Detroit, with music, food and drink, and other diversions. Hours are 6-11 p.m. Friday, noon to midnight Saturday, and noon to 10 p.m. Sunday.

**YUSEF** Lateef performs at 5 p.m. Tuesday in the Renaissance Live series on the Ontario level deck of the Detroit Plaza Hotel. Tickets are \$7, available by calling 568-8317.

**MONROE** is holding its annual Old French Town Days Saturday and Sunday, with 300 costumed participants recreating an 18th century military camp. Mock battles will be staged, complete with cannon and tactical maneuvers. Crafts will be demonstrated, and food will be available. It takes place 10 a.m. to 5 p.m. on the campus of Monroe County Community College, a mile south of M-50 on Raisinville Road.



### Country dancing

The Cobblestone County Dancers, who do 19th century American steps, will perform at 2 p.m. Saturday as part of this weekend's annual Dixboro Festival, which includes homemade pastries and barbecued chicken dinners, an arts and crafts fair, carnival booths and rides on antique fire trucks. The festival, which runs all day Saturday, is on the Village Green in the town of Dixboro, on Plymouth Road between Ann Arbor and Plymouth.

## 5 planets in Cranbrook demonstration

"The Wanderers," five planets once believed by Greeks and Romans to be drifting stars, will be the topic of planetarium demonstrations at Cranbrook Institute of Science in July and August.

The 35-minute program studies earth probes sent to Mercury, Venus, Mars, Jupiter and Saturn. Jupiter's four largest moons will also be discussed.

Planetarium shows are at 1 and 2 p.m. weekdays; 4 p.m. Wednesdays; 2, 3, 4 and 7:30 p.m. Saturdays and 2, 3 and 4 p.m. Sundays.

Demonstrations are free with museum admission of \$2.50 for adults, \$1.50 for students and senior citizens.

### auditions

● The Performing Arts Guild will hold auditions for the musical "Man of La Mancha" 7:30-11 p.m. July 27-28, with callbacks on July 29. All tryouts will be at the Marquis Theater, 133 E. Main in Northville. The play will be presented in September.

Auditioners will be required to perform one prepared vocal selection and to supply their own sheet music; an accompanist is provided. A photo and resume are requested. For more info, call 833-2367.

● Garden City Civic Theater is accepting applications for director of "The Girls in 509," an election-year comedy scheduled for a four-day run in October. To arrange for an interview, call president Diane Kremser after 5 p.m. at 427-0064.

### DALE YEE'S CHOW MEIN

Finest Chinese & American Restaurant with carry-out service

Serving The Livonia Area for 10 Years

**COCKTAILS AND POLYNESIAN DRINKS COMBINATION DINNERS AVAILABLE for LUNCH and DINNER**

Hours: MON-THURS 11 a.m. to 11 p.m.  
FRI & SAT 11 a.m. to Midnight  
SUNDAY and HOLIDAYS Noon to 10 p.m.

**31180 FIVE MILE LIVONIA 522-1030**

Most Major Credit Cards Accepted

DINING AND ENTERTAINMENT GUIDE

## ON THE TOWN

THE PARADISE DINNER THEATRE PRESENTS

### 6 RMS RIV VU

Six Rooms River View Bright and sunny Broadway comedy hit by Bob Benda with hot and cold running with hot lines, beautiful views of a charming park who get locked in while inspecting N.Y. state apartment

Directed by EDGAR A. GUEST, III SATURDAY PERFORMANCE

869 3988  
17630 Woodward

Continuous Daily Matinees All Seats \$ 1.50 First 2 Shows  
Robert Redford is **"BRUBAKER" (R)**

Burt Reynolds **"ROUGH CUT" (PG)**

Two Clint Eastwood Action Comedies **"BRONCO BILLY" (PG)**  
**"EVERY WHICH WAY BUT LOOSE" (PG)**

John Travolta **"URBAN COWBOY" (PG)**  
John Travolta & Olivia Newton-John **"GREASE" (PG)**

### SZE CHUAN RESTAURANT

Specializing in tantalizing spicy Mandarin Cuisine  
"The Ultimate in Chinese Food"  
Come in and try us, it will be an experience your taste buds will not soon forget  
45 188 FORD RD. • CANTON  
(across from Meijer Thrifty Acres) Carry-out Delivery  
OPEN 7 DAYS A WEEK 459-3960

DINING AND ENTERTAINMENT GUIDE

### This Week's Specialty

FILET OF SOLE NORMANDE  
Sautéed sole, accompanied with shrimp and mushrooms. Includes: salad, fresh bread, rice, plate or baked potato and fresh vegetable \$8.25

#### Meriwether's

Telegraph, North of 10 Mile Southfield, Warren 528-4950    Van Dike, South of 13 Mile Warren 574-9620

BEEN LOOKING FOR SOMETHING TO LAUGH ABOUT LATELY?...

W4 Announces in conjunction with Fleming and Associates The National Touring Company of

## SECOND CITY

Saturday July 26 and Sunday July 27 Shows at 8:00 p.m. and 10:30 p.m.  
Punch and Judy Theatre, Grosse Pointe Farms  
Tickets: \$7.00 and \$8.00

Tickets available at all CTC Outlets Sams Jams in Ferndale Schooldisks Records in Ann Arbor the Punch and Judy Box Office. Tickets by mail order. Send check for amount along with a stamped self-addressed envelope to SECOND CITY c/o Fleming and Associates 201 S. Main St. Suite 409 Ann Arbor MI 48104 For more information call (313) 995-9666 or (313) 881-4510

### Adams Towne House

## "SPECIAL" OUR SUNDAY BREAKFAST BRUNCH

Adults \$4.95 **ONLY \$3.95** with this coupon

Children (under 10) \$3.95  
10:00 AM-2:00 PM  
All You Can Eat

30843 PLYMOUTH RD. 2 BLKS. E. OF MERRIMAN 421-5060

### LUNCH & DINNER SPECIALS

Monday: Veal Cutlet Dinner  
Tuesday: Roast Beef  
Wednesday: Spaghetti  
Thursday: Barbeque Chicken (with this coupon)

Above dinners include potatoes, vegetable, rolls & butter (Expires 7-24-80)

Friday: FISH & CHIPS \$1.99  
Includes fries, cole slaw, rolls & butter

MIDNIGHT SPECIAL  
Roast Beef on Kaiser Roll with a cup of soup & coffee (11:00 p.m.-4:00 a.m.) \$3.00

#### Hank's Place

FAMILY RESTAURANT  
31461 FORD RD. (west of Merriman) 425-7490 OPEN 24 HRS.

### QUO VADIS 21 CLUB

OPEN 5:00 P.M. DAILY 1 P.M. SUNDAY

This coupon entitles your entire party to...

## DINNER & MOVIE

\$4.95 PER PERSON (with this coupon) (Offer expires 8-1-80)

Your choice of any dinner on our menu plus any one of four first run movies. Discount prices valid Monday thru Thursday evenings and Sunday 1-6 P.M. Regular prices apply Friday, Saturday, Sunday Evenings. 7420 WAYNE ROAD. (at Warren) WESTLAND 261-4530

### PRIME RIB DOVER SOLE PORTERHOUSE STEAK

Are our Specialties... But that's not all... We've a dinner menu just brimming with good things to eat. Forty entrees available to choose from. Distinctive dining, charming, warm atmosphere with copper-hooded fire-place.

LIVE ENTERTAINMENT From 5 PM 'til 2 AM

DINNER SERVED from 5 PM to MIDNIGHT

#### CHEF'S SPECIAL

11 oz. N.Y. STEAK ..... 6.95  
BROILED Fla. RED SNAPPER... 6.95

Complete Dinner Includes Soup, Salad and Potato or Vegetable

**the Red Cedars** 353-5170  
Telegraph at 9 Mile Southfield

# Madness & Melodrama

### Henry Ford Museum Theater

State of the Union  
Fri. & Sat., June 20-21

Needles and Pins • The Ghost Train  
Fri. & Sat., Aug. 1-Sept. 6    Fri. & Sat., Oct. 10-Nov. 15

#### Dinner Theater

Optional cocktail reception, candlelight dinner, followed by the Greenfield Village Players' stage presentation.

Call 271-1620, Ext. 414 for information and reservations—groups or individuals. Individual performance tickets (Theater only or Dinner/Theater) available.

## HENRY FORD MUSEUM

Dearborn, MI 48121

Cocktail Specials Daily

### MOY'S

RESTAURANT • EXOTIC COCKTAILS •  
Carry-outs on Chinese Food  
CHINESE LUNCHEON 11 AM-3 PM  
JAPANESE LUNCHEON 11 AM-2 PM  
DINNERS 5-9:30 PM  
FRI. & SAT. 11-10:30 PM  
Closed Mondays

16825 MIDDLEBELT AT SIX MILE • LIVONIA 427-3171

### GARY PRIMO

AT THE KEYBOARD TUES.-SAT.

Dine & Dance to Oldies, Rock n' Easy & Disc Spin live by our own DJ  
9-2 Fri. & Sat. No Cover  
Lunch & Dinner Mon.-Sat.

JOIN US FOR HAPPY HOUR & MUNCHIES  
3:30-7 Mon.-Fri. • 4:15 Sat.

32305 Grand River 14 Mile West of Orchard Lk. Call for Reservations 478-1616  
OPEN M-W 11-12, Th-Sat. 11-3

### TEN YEN

千元酒家

425-8910

WAYNE ROAD AT ANN ARBOR TRAIL  
LIVONIA

### CHINA FAIR

京華酒家

349-0441

NORTHVILLE PLAZA MALL  
42313 W. 7 MILE RD.  
NORTHVILLE  
NOW SERVING COCKTAILS

CHINESE, CANTONESE, HONG KONG, MANDARIN  
JAPANESE & AMERICAN CUISINE

BUSINESSMEN'S LUNCHEON SPECIALS • COMPLETE DINNERS • CARRY OUT SERVICE • BANQUET ROOM  
(OPEN 7 DAYS)

Fairlane 1 & 2  
Ford Road at Telegraph, 561-7200

Maple 1-2-3  
on W. Maple at Telegraph ad. to Bloomfield Plaza 855-9990

Northland 1 & 2  
J.L. Hudson Drive • Northland Center 559-3366

Old Orchard 1-2-3  
On Orchard Lake Rd. N. of 12 Mile 553-2210

Terrace 1 & 2  
30400 Plymouth Rd. near Middlebelt 937-1717 427-1200

Towne 1 & 2  
Greenfield Road N. of 11 Mile at Huron Center 968-8700

Abbey 1-2-3-4  
Across from Oakland Mall on 14 Mile at 175 588-0881

Fairlane 1 & 2  
Ford Road at Telegraph, 561-7200

Maple 1-2-3  
on W. Maple at Telegraph ad. to Bloomfield Plaza 855-9990

Northland 1 & 2  
J.L. Hudson Drive • Northland Center 559-3366

Old Orchard 1-2-3  
On Orchard Lake Rd. N. of 12 Mile 553-2210

Terrace 1 & 2  
30400 Plymouth Rd. near Middlebelt 937-1717 427-1200

Towne 1 & 2  
Greenfield Road N. of 11 Mile at Huron Center 968-8700

# Peppy

## GOP convention music meant 'to wake them up'

By TOM LONERGAN

Only 35 persons received the special credential "entertainer" at this week's Republican National Convention in Joe Louis Arena. Yet most got the worst seats in the house.

"I can't see the rostrum," convention band conductor Manny Harmon said after Monday's opening convention session.

"They put the damn cameras so high, I can't see a thing."

Harmon, from Los Angeles, and the 30-piece band were directly behind the giant scaffolding supporting the all-important television cameras.

BUT HARMON is used to such placement. The Detroit convention was his sixth for the Republicans. And except at Kansas City in 1976, the band was put behind some large obstruction.

Prior to and between speeches, delegates' ears were kept occupied by the band, most of whose members were from the Detroit area and recruited by John Trudell.

One band member described the selections as "occasional greeting cards."



The selections included rock, big band medleys and selections from Glen Miller.

"Peppy music to wake them up," was the way Harmon described it. "I've got close to two tons of music here," he said.

During the 20 years he has been filling in the spaces of the convention shows, Harmon said the Republicans' choice for convention music has changed little.

"They like the peppy stuff... like to keep it alive," he said.

At the conclusion of Monday's first session, one of the numbers was "Glory, Glory Hallelujah" (refrain line of "Battle Hymn of the Republic").



Manny Harmon and his Orchestra have the worst seats in the house for the Republican National Convention. (Staff photo by Dick Kelley)

Many Detroiters, however, probably recognized it as the same music for the union anthem, "Solidarity Forever."

"That's just a song we picked," said Harmon. "We didn't pick it on the basis that it happened to be a union song."

A MUST for the band members is mastering the state songs played to introduce each of the speakers.

"It's all written out for you. All you have to do is play it," said one band member.

"It's kind of strange," said saxophone player Ernie Rodgers of De-

troit. "We're playing it as we go."

This evening, the introduction number for Ronald Reagan's address to the convention will be, "I Love You, California," the "official" state song, Harmon said.

"Everyone thinks (the state's song)

is 'California, Here I Come,'" Harmon added. "But we're already there, you see."

Harmon's last visit to Detroit was in the late 1950s, "to open Cobo Hall with the Mills Brothers."



### Jazz stars group in free concerts

Twenty local jazz performers have been brought together by Channel 4 to form the Detroit All Stars, which will give four free outdoor concerts throughout the metro area in July and August. The first of the four will be 5-6:45 p.m. Tuesday in the amphitheater of Hart Plaza in downtown Detroit; also performing will be a jazz quintet, Ursula Walker and the Wayne State University Jazz Lab Band. The final All Stars performance will be Aug. 12 in Livonia's Civic Center Park.

## New galleries open at Institute of Arts

A new area of the Detroit Institute of Arts, constructed around the high spaces of the North Court as a showcase for African and Native American collections, is now open.

An exhibition concourse and three carpeted galleries surround the one-story rise of a walled sculpture garden under the skylight of the museum's North Wing. A new stairway gives direct access to these ground level galleries from the museum's main floor.

The new exhibition space which will soon add two more galleries for Oceanic and Pre-Columbian art, enables us for the first time to display our ranking traditional African art and our growing collection of native American art," said museum director Frederick J. Cummings.

Featured in the \$1.2 million wing are the recently dedicated J.L. Hudson Co. Gallery and the Webber Foundations Gallery, both devoted to African Art. Other funding sources were a City of Detroit bond issue, the National Endowment for the Arts, the State of Michigan and the Kool Jazz Festival.

A plaque honoring the Friends of African Art, a Founders Society group which has supported the museum's African program for more than 15 years, is also installed.

Native American art will be distinguished by a special loan of the work of Woodlands tribes from the collection of Richard A. Pohrt of Flint, Plains, Great Lakes and West Coast Indian blankets, basketry and pottery from the museum's collection will be displayed as well as fine Eskimo sculpture.

All galleries in the new area are under the direction of Michael Kan, deputy director and curator of African,



Oceanic and New World Cultures. Architect was John D. Hilberry and Associates of Detroit. Installation design was by Charles Froom of New York City.

The African collection numbers more than 800 objects, one of the largest assemblies of traditional African art in the U.S. Nucleus of the collection was established by important gifts received from the late Robert Tannahill of Grosse Pointe Farms and from Justice and Mrs. G. Mennen Williams of Grosse Pointe Farms.

Substantial purchases were made since 1965 by former museum director Willis F. Woods and by the Friends of African Art (formerly the African Art Gallery Committee).

Since 1976 Kan has strengthened the collection through a \$1.2 million gift from the late Eleanor Clay Ford, to be spent exclusively for acquisition of African art. The museum's first major purchase from this fund was the large Kongo nail figure from Zaire, \$275,000, the highest price ever paid in the United States for an African object.

Regular museum hours are 9:30 a.m. to 5:30 p.m. Tuesday-Sunday. Closed Mondays and holidays.

## P'Jazz

### Dixieland bands playing next week

The Dixieland bands of Chet Bogan and Percy Gabriel will play at Chuck Muer's P'Jazz on Monday, with Windsor flutist Alexander Zonjic scheduled for Wednesday on the terrace at Detroit's Hotel Pontchartrain.

Both shows start at 6 p.m. Tickets are priced for general admission and for reserved seats. Reserved tickets may be ordered from 10 a.m. to 5 p.m. Monday-Friday at the Pontch, 965-0200. General admission tickets are sold the day of all shows, beginning at 5 p.m.

Admission will be free Monday to any P'Jazz pa-

tron wearing a P'Jazz T-shirt from any of the last four years.

New Orleans is the home of Dixieland music and it's also the home of Percy Gabriel, who brings his New Orleans Dixie Land Jazz Band to P'Jazz on Monday.

"WE INHERITED our sound — we didn't get it listening to records," said Gabriel, who has played with the Red Allen Jazz Band and different Preservation Hall groups.

Playing alternate sets with Gabriel's band will be Detroit's Chet Bogan, a dentist by day who plays trumpet with his Wolverine Jazz Band by night. A

star attraction with Bogan's group is vocalist Dixie Belle.

At the age of 27, flutist Alexander Zonjic is undoubtedly the best-known jazz artist in Windsor. He's been playing jazz at Antonelli's for the last two years but is equally comfortable with classical music at the Windsor Art Gallery. Sometimes he plays in duets with the Detroit Symphony Orchestra's principal flutist Ervin Monroe.

Zonjic has one album and several television appearances to his credit. He and his five-member group will make their first P'Jazz appearance on Wednesday.

## Meadow Brook

### The DSO and Loretta Lynn this weekend

James Galway plays his flute at 8:30 p.m. Thursday with the Detroit Symphony Orchestra at Meadow Brook Music Festival.

Thursday's conductor is British-born Raymond Leppard who has made headlines in opera houses and concert halls around the globe. He will lead the Detroit Symphony Orchestra in a program of Rimsky-Korsakov, Bach, Mozart and Stravinsky.

Coal miner's daughter Loretta Lynn sings her sad country songs at 8:30 p.m. Friday. Johnny Russell opens the show.

Leppard returns to the podium at 8:30 p.m. Saturday to conduct the Detroit Symphony Orchestra with mezzo-soprano Claudine Carlson and tenor Frank Little soloing. Music by Schubert and Mahler is featured.

Pianist-conductor John Covelli appears at 7:30

p.m. Sunday with the Detroit Symphony Pops.

THE GROUNDS are open 2½ hours before evening concerts for picnicking or dining at Trumbull Terrace.

All concerts are held in the Baldwin Pavilion on the Oakland University campus near Rochester, with entrances on Walton Boulevard and Adams

Road. More than 7,000 people can sit in the pavilion and on the lawn.

For tickets, dinner reservations or program information call the festival box office, 377-2010. Tickets also are available at Hudson's and other Convenient Ticket Co. locations, Sears, Grinnell's and Discount Records.

### Attendance reaches high

Meadow Brook, the professional theater on the campus of Oakland University, hit an audience high of 96.2 percent of paid capacity during the season that closed in May.

This figure compares favorably with the local

theater's 1978-79 season which played to 94.1 percent of paid capacity.

At this time more than 12,000 subscribers have renewed for the coming season, leaving 5,000 seats for public sale.

## Detroit Jazz Center has loads of music through the weekend

The Detroit Jazz Center is welcoming delegates to the city's first national political convention with a week-long Convention Jazz Festival in the downtown Jazz Center, 2100 Park Ave. at Elizabeth, just north of Grand Circus Park.

The Convention Jazz Festival features 2-5 p.m. jam sessions in the Jazz Gallery concert cafe; a Convention Jazz Clinic, with workshops daily from 5-8 p.m.; and nightly performances by local artists in the Jazz Gallery from 10 p.m. to 4 a.m.

A special convention concert, Renaissance Jazz Revue with Kenny "Pancho" Hagood, Paul Leonard, Herbie Williams, Sam Sanders and the Pioneer Jazz Orchestra, will be held at midnight Thursday in the center's World Stage Ballroom.

The festival also will feature a Jazz Forum on the history of the Detroit Jazz Center Project, 8-10 p.m. Thursday in the Charlie Parker Room; an exhibition of jazz posters from Detroit and Michigan, daily from noon to 2 a.m. in the Jazz Gallery; and the following nightly concerts in the Jazz Gallery:

Kummba (Big Band), Thursday; Sam Sanders and Visions, Friday-

Saturday; Vassal Gradington Group, Sunday; and after-hours jazz with the Allan Barnes Band, 2-6 a.m. Friday-Saturday. Showtimes are between 10 p.m. and 4 a.m. nightly during the convention week.

THE RENAISSANCE Jazz Revue is a new component of the Performing Arts Program at the Detroit Jazz Center and features a 1940s-style revue format with music from the classical jazz repertoire.

Featured in the revue are vocalists Kenny "Pancho" Hagood and Angela Smith, tap dancer Paul Leonard, saxophonists LaMont Hamilton and Sam Sanders; trumpet soloist Herbie Williams; and members of the Pioneer Jazz Orchestra, including David Swain, Chris Pitts and Vincent York, reeds; Ron Jackson and Jim Van Dyke, trumpets; Dan McAllister and Mike Pashanee, trombones; Rod Williams, piano; Ed Pickens, bass; and Ronnie Jonson, drums.

John Sinclair is the show's master of ceremonies.

For more information on the Convention Jazz Festival, call the center at 962-4124.



# Gay voters to test Republican waters

By JUDITH BERNE

Four years ago there were none. This year there are two.

There are two openly gay delegates to the Republican National Convention.

And Timothy E. Drake, a homosexual delegate from Illinois, Tuesday said Ronald Reagan's choice of a running mate will determine whether gays can support his candidacy.

At a sparsely attended press conference in Detroit's Cobo Hall, Drake said Reagan "has proven in the past he was willing to give us a fair break. But we have some concerns we want to express."

*Reagan 'has proven in the past he was willing to give us a fair break. But we have some concerns we want to express.'*

— Timothy E. Drake, homosexual delegate from Illinois

front of a microphone," he added, with a smile. "We are making a very profound statement in being here. We are activists but somewhat realistic. I want some assurance they aren't anti-gay."

Sen. Paul Laxalt of Nevada, among a number of candidates Reagan is reportedly considering for vice-president, was the only one named totally unacceptable by Drake.

In choosing Laxalt, "he would be writing off all the gay vote," Drake flatly said.

Drake said among the three potential presidential candidates — Reagan, President Carter and John Anderson — "Anderson has an impeccable gay rights stand. His position paper is as if we wrote it," he said.

"Is there any reason to stay within the Republican Party?" Drake was asked.

"THE REPUBLICAN PARTY isn't going to go away," he responded. "I have put in too many years in the Republican party. I support its stand on foreign and economic issues. I have a lot of trouble with social issues. The answer is not to walk out, but to hang in there."

Four years ago, the Democratic Convention registered "two or three" openly gay delegates, according to Drake. Next month they are expecting more than 75, he said.



Most of these are tied in with the Republican's conservative platform which works against minority rights.

"It's my belief that this platform doesn't represent the Republican party as a whole," Drake said. "The moderates have just been trampled at this convention."

"It's our fault," he continued. "We allowed the radical fringe to gain control."

"GOV. REAGAN is a strong advocate of individual rights," said Drake. "He has the potential to generate good will among gay Americans, of which there are an estimated eight million in the United States."

"They're not all open and standing in



The way it is

Walter Cronkite, the only anchor the CBS Evening News show has had in its 18-year history, seems relaxed in his perch high atop the convention floor at Joe Louis Arena. Cronkite, 64, will retire from full-time assignments at CBS next year. (Photo by David Frank)

# Convention's telephone hookups simple as GOP

By CRAIG PIECHURA

There are countless more people involved in the Republican convention than the 2,000 delegates, 2,000 alternates and 8,000 members of the working press assigned to cover them.

At Michigan Bell alone there are about 400 persons from various departments of the company who have been assigned to work solely on convention business. In addition, 100 technical specialists were brought in from the American Telephone and Telegraph Co. to assist in the communications set-up serving a temporary population the size of a city such as Marquette.

One year after joining Michigan Bell, Joseph Luginski, 20, of Southfield was pulled out of his job in the Redford business office to work at the Convention Control Center as a customer service representative.

It's Luginski's job to make sure that business customers, primarily the American Broadcasting System (ABC), have all the phones, phone lines, transmission cables and microwave equipment they need to cover the convention. The marketing department at Michigan Bell has set up what it calls a SWOT team, which stands for statewide order transmittal, at the convention site. Luginski makes sure that whatever SWOT orders, the client gets.

HE'S WORKED the last 17 days in a row and expects to be working another eight straight. Instead of griping about the long hours, Luginski says he volunteered for the assignment and explains that he's thrilled to be a part of the convention.

"It's a good experience for me," Luginski said. "The idea of working on one of the major events of the year, this is exciting to me."

According to a Bell spokesman, the phone company's convention task force has installed enough cable around Joe Louis Arena and Cobo Hall to ring the globe — some 25,000 miles of the stuff.

To serve the convention, the phone company established a special exchange — 467 — which corresponds to the letters "GOP." Consequently, the number for the Republican Arrangements Committee is GOP-1980.

SECURITY IS so tight that utility manholes were cemented shut downtown to foil sabotage of convention communication transmission.

Phones and phone lines are in every conceivable place and then some. For example, Luginski had to send a crew to Kennedy Square to install a bank of temporary phones outdoors for the press covering Monday's mass demonstration by persons supporting passage of the Equal Rights Amendment.

Those phones, the GOP exchange, the manholes and most of the miles of cables will be unneeded after Sunday. Michigan Bell purchased much of its equipment from New York Bell after the Winter Olympics in Lake Placid. The utility plans to re-sell much of the same equipment back to New York Bell for use in next month's Democratic convention.

The hoopla is exciting and the responsibility of running a convention smoothly is a challenge, Luginski says. "I heard somebody down here say that seeing all this makes them proud to be an American," Luginski said. "It kinda does. You can see a major event and you're a part of it. Who knows, this might be a once-in-a-lifetime chance to see a political convention in Detroit. There's a certain pride to say 'I had a part in the 1980 Convention.'"

# CHATHAM

TRY OUR...

# OKonomy CHALLENGE

## \*FREE!

**OKonomy MACARONI AND CHEESE DINNER (7 1/4-oz.)**

\*With the box top or label from any brand or size Macaroni-Cheese except Chatham or OKonomy brand. Limit: One (1) per family please, this offer good Wed. July 16 thru 6 P.M. July 22, 1980.

Bring in the label from any brand of macaroni & cheese, except Chatham or OKonomy brand and we'll swap it for OKonomy Macaroni & Cheese. We want you to try OKonomy at no cost to you the first time, because we think you'll use OKonomy products on a regular basis once you find out how good they are.

## SAVE UP TO 60% OVER... NATIONAL BRANDS

- |  |   |   |   |
|--|---|---|---|
| PIECES & STEMS<br><b>OKonomy MUSHROOMS</b><br>4-OZ. CAN <b>44¢</b>   | OKonomy<br><b>TOMATO CATSUP</b><br>2-LB. JUG <b>69¢</b> | OKonomy<br><b>SALAD DRESSING</b><br>QT. JAR <b>79¢</b>            | GENERIC<br><b>SALTINE CRACKERS</b><br>1-LB. PKG. <b>49¢</b>   |
| OKonomy<br><b>BEEF DOG FOOD</b><br>15-OZ. <b>22¢</b>                 | OKonomy<br><b>CREAM STYLE CORN</b><br>8-OZ. <b>15¢</b>  | OKonomy<br><b>CUT GREEN BEANS</b><br>1-LB. <b>31¢</b>             | OKonomy<br><b>PEANUT BUTTER</b><br>1-LB. 2-OZ. <b>88¢</b>     |
| OKonomy<br><b>GARDEN SWEET PEAS</b><br>1-LB. CAN <b>3 FOR 1</b>      | OKonomy<br><b>WHOLE KERNEL CORN</b><br>1-LB. <b>29¢</b> | OKonomy<br><b>WHOLE MARSHMALLOWS</b><br>1-LB. PKG. <b>2 FOR 1</b> | OKonomy<br><b>BATHROOM TISSUE</b><br>6 PK. <b>1 19</b>        |
| OKonomy<br><b>COFFEE CREAMER</b><br>1 LB. 6-OZ. CANISTER <b>1 22</b> | OKonomy<br><b>TOWELS</b><br>125 CT. <b>49¢</b>          | OKonomy<br><b>LIQUID DETERGENT</b><br>QT. <b>49¢</b>              | OKonomy<br><b>Pure Shortening</b><br>2-LB. 10-OZ. <b>1 19</b> |

PRICES EFFECTIVE JULY 16 THRU 6 P.M. JULY 22, 1980 AT ALL CHATHAM STORES. NO SALES TO DEALERS OR WHOLESALE BUYERS. NO CASE SALES ON AD ITEMS.

ALL MANUFACTURER'S COUPONS UP TO AND INCLUDING 50¢ FACE VALUE

# CHATHAM COUPON AND A HALF

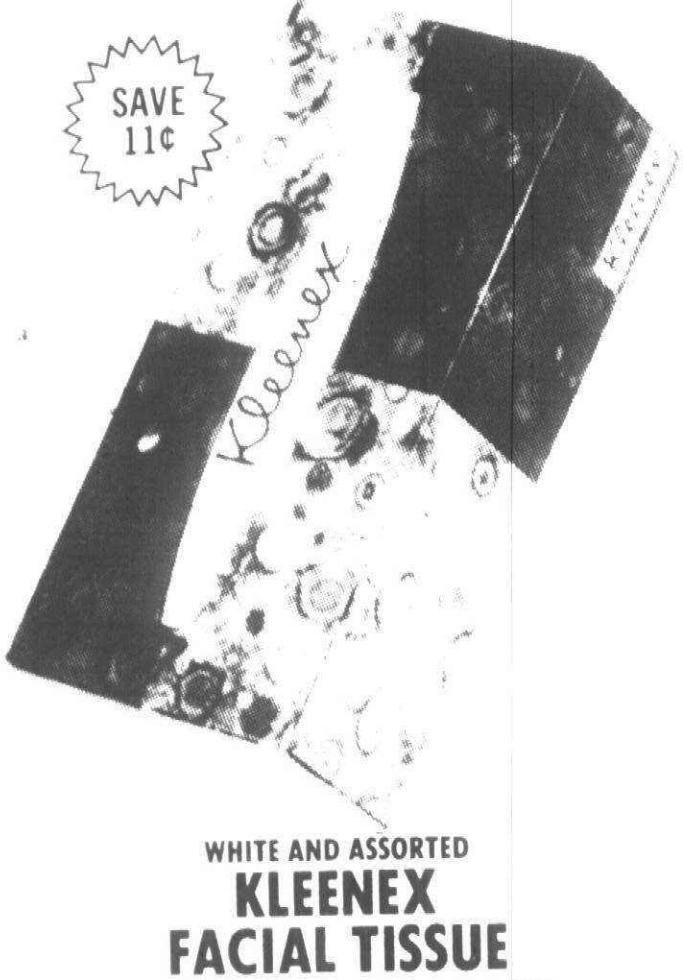

SAVE 11¢

WHITE AND ASSORTED  
**KLEENEX**  
FACIAL TISSUE

200 CT. **58¢**

LIMIT 3 PLEASE

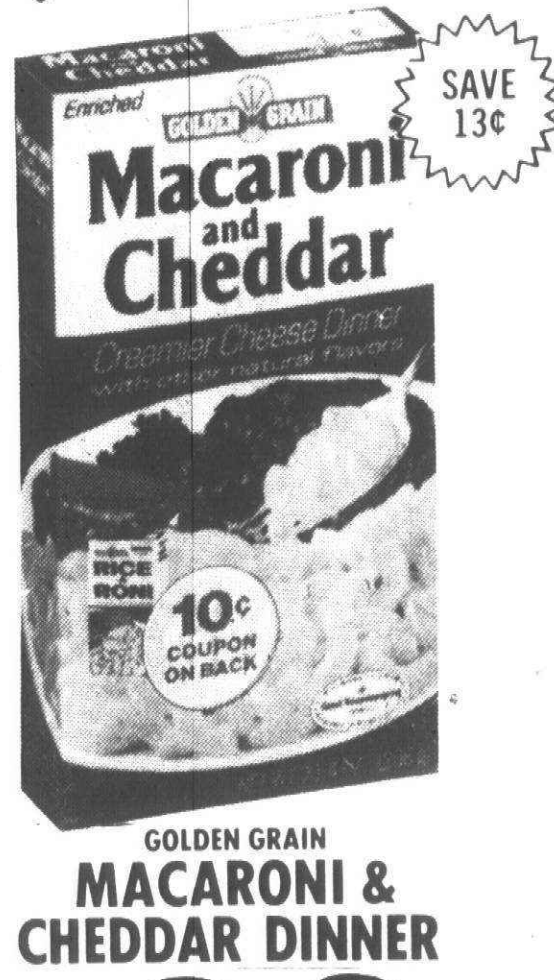

SAVE 13¢

GOLDEN GRAIN  
**MACARONI & CHEDDAR**  
DINNER

7 1/4-OZ. BOX **22¢**

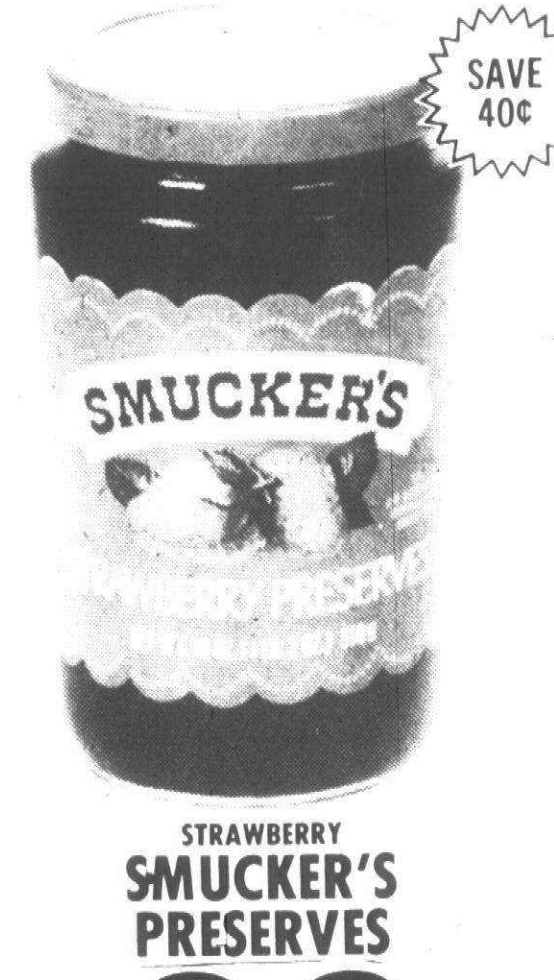

SAVE 40¢

STRAWBERRY  
**SMUCKER'S**  
PRESERVES

1-LB. 2-OZ. JAR **98¢**

LIMIT 2 PLEASE



SAVE 45¢

LUNCHEON MEAT  
**HORMEL SPAM**

12-OZ. CAN **99¢**

LIMIT 2 PLEASE



20¢ OFF LABEL  
**PALMOLIVE**  
DISH LIQUID

QT. BTL. **1.19**



NEW

PRE-PRICED  
**TWIN PACK**  
JOB SQUAD

TWIN PACK **1.29**



35¢ OFF LABEL  
**OXYDOL**  
DETERGENT

5-LB. 4-OZ. BOX **2.49**



13¢ OFF LABEL  
**DAWN**  
DETERGENT

1-PT. 6-OZ. BTL. **99¢**

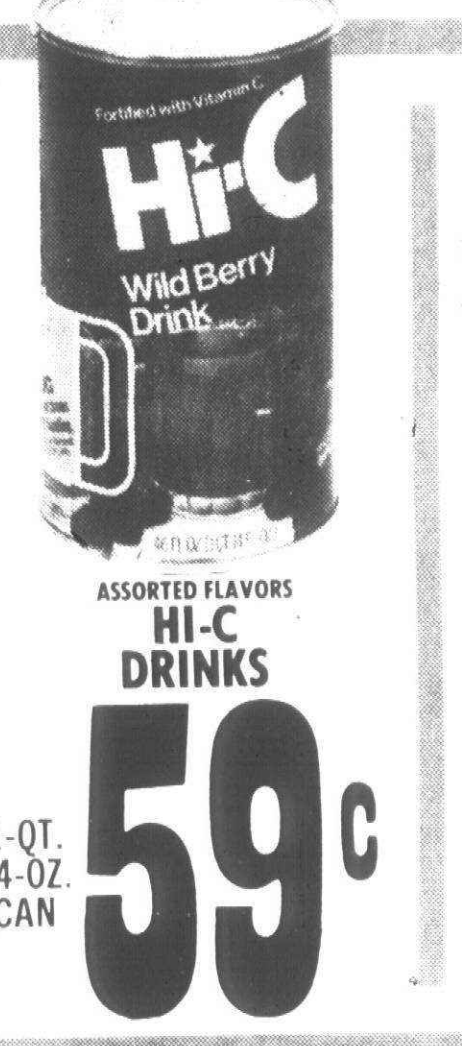

ASSORTED FLAVORS  
**HI-C**  
DRINKS

1-QT. 14-OZ. CAN **59¢**

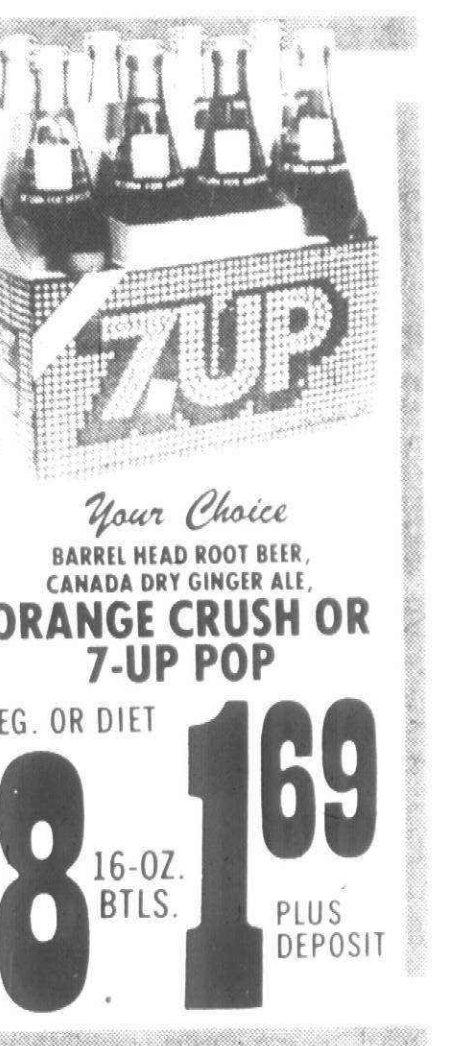

Your Choice  
BARREL HEAD ROOT BEER,  
CANADA DRY GINGER ALE,  
**ORANGE CRUSH OR**  
**7-UP POP**

REG. OR DIET

16-OZ. BTL. **8.169**

PLUS DEPOSIT

PRICES EFFECTIVE AT ALL CHATHAM STORES AND CHATHAM PLUS JULY 16 THRU 6 P.M. JULY 22, 1980. NO SALES TO DEALERS OR WHOLESALE BUYERS. NO CASE SALES ON AD ITEMS.

ROTINI, RIGATONI OR LISCI  
**PRINCE**  
PASTA

1-LB. PKG. **2 FOR \$1**

20¢ OFF LABEL  
**CRISCO**  
OIL

1-QT. 6-OZ. BTL. **1.59**

FRENCH OR 1000 ISLAND  
**KRAFT**  
DRESSING

1-PT. BTL. **98¢**

CHILLY  
**ORANGE CREAM**  
OR  
**FUDGE BARS**

12-CT. FUDGE OR 14-CT. ORANGE CREAM **88¢**

CHATHAM  
**COFFEE**  
CREAMER

16-OZ. JAR **99¢**

MASTER BAKERS SANDWICH OR  
**LARGE**  
WHITE BREAD

1-LB. 8-OZ. LOAVES **2 \$1**

Your Choice  
**VERNORS OR**  
**A&W ROOT BEER**

8 HALF LITER BTL. **1.77**

PLUS DEPOSIT

KITCHEN KING  
**PEANUT**  
BUTTER

1-LB. 2-OZ. JAR **88¢**

GENERAL COFFEE  
**100% PURE**  
COLOMBIAN COFFEE

1-LB. BAG **2.28**

THANK YOU  
**CHERRY PIE**  
FILLING

1-LB. 5-OZ. CAN **99¢**

OCEAN SPRAY  
**GRAPEFRUIT**  
JUICE

1-PT. 1-PT. **99¢**

DELICIOUS  
**TREE TOP**  
APPLE JUICE

2-PT. BTL. **1.29**

FROZEN TYSON OR  
**MORTON**  
FRIED CHICKEN

2 LB. PKG. **1.69**

NATURAL SUN  
**ORANGE**  
JUICE

FROZEN 12-OZ. CAN **79¢**

ALL SIZES & SHADES  
**SHEER COMFORT**  
PANTY HOSE

REGULAR & NUDE **88¢**

REGULAR 1.09

LADIES WRANGLER OPAQUE KNEE HI'S 3-PK. 1.88

SAVE 60¢

NORMAL, OILY  
**PERT**  
SHAMPOO

7-OZ. **99¢**

SAVE 40¢

**CLAIROL**  
FINAL NET

8-OZ. **1.77**

SAVE 50¢

**LISTERINE**  
MOUTHWASH

QT. **1.89**

SAVE 50¢

**CARE FREE**  
PANTY SHIELDS

30 CT. **1.38**

REGULAR OR NEW DEODORANT

25% OFF MENS  
**WRANGLER**  
ATHLETIC HI-RISE  
TUBE SOCKS

6 PK. **4.44**

REGULAR 5.99

DRESS SOCKS 6 PK. 4.44

40¢ OFF LABEL  
**FAB**  
DETERGENT

5-LB. 4-OZ. BOX **2.89**

**SAFE GUARD**  
BATH SOAP

5-OZ. BAR **49¢**

**CUT RITE**  
WAX PAPER

100-FT. ROLL **69¢**

20¢ OFF LABEL  
**ELECTRASOL**  
DETERGENT

1-LB. 6-OZ. **2.19**

ASSORTED  
**ON-COR**  
DINNERS

TURKEY SALISBURY MOSTICOLI VEAL

2 LB. PKG. **1.79**

Chatham gives you 50% more on all "cents-off" manufacturers' coupons up to and including 50¢ face value. Other retailers and "free" coupons excluded. Limit one coupon for any one product. Coupon plus 50% bonus cannot exceed the price of the item.

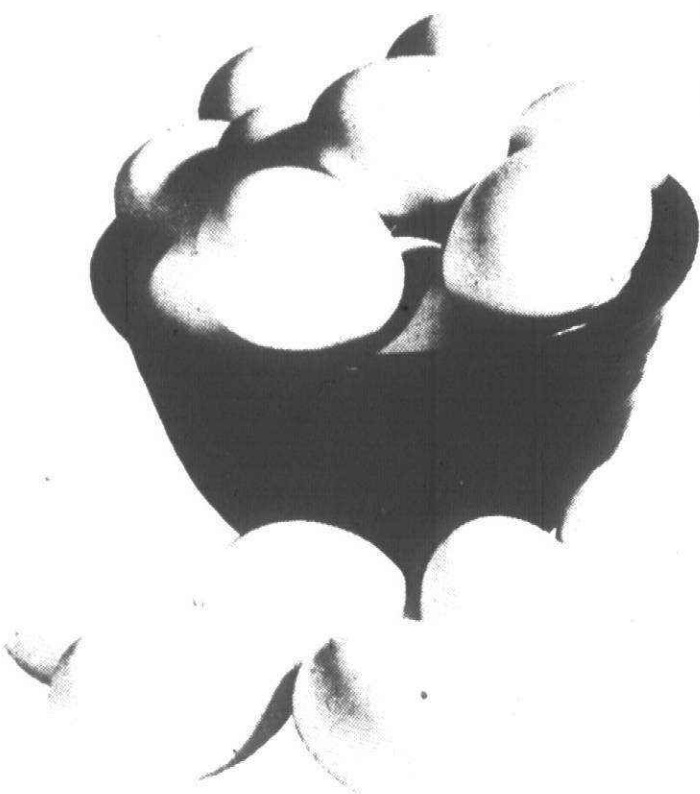

ROSE ACRE  
GRADE A FRESH  
LARGE EGGS

**53<sup>c</sup>**

DOZEN  
CTN.  
LIMIT 3  
DOZEN  
PLEASE



KRAFT  
PARKAY  
MARGARINE

**49<sup>c</sup>**

1-LB.  
IN  
QTRS.

"NEW"  
DECAFFINATED  
INSTANT  
HIGH POINT COFFEE

**4<sup>99</sup>**

GENERIC  
GRANULATED  
PARMESAN

**99<sup>c</sup>**

8-OZ.



MICHIGAN GROWN  
GREEN  
CABBAGE

**18<sup>c</sup>**

LB.

# PORK SALE

HAMBURGER MADE FROM ...  
**GROUND CHUCK**

**1<sup>55</sup>**

LB. ANY SIZE PACKAGE. SAME PRICE PER POUND. GROUND FRESH SEVERAL TIMES DAILY.

HAMBURGER STEAK ... LB. 1.29

FRESH GOVT. INSPECTED  
**PORK LOIN ASSORTED CHOPS**

3 to 5 LB. AVG.

**1<sup>09</sup>**

LB. CONTAINS CENTER AND END CUT CHOPS

FRESH CUT WHOLE CRY-O-VAC  
**BONELESS BEEF BRISKET**

**1<sup>39</sup>**

LB.

JENNIE-O  
**TURKEY WINGS**

**29<sup>c</sup>**

LB. FAMILY PACK 4 to 6 LB. AVG.

AGAR  
**CANNED HAM**

**5<sup>699</sup>**

LB. CAN 3-LB. CAN HAM 4.99

Wilson Corn King  
**SLICED BACON**

**79<sup>c</sup>**

12-OZ. PKG.

**FAMILY PACK SAVINGS**

FULLY COOKED, SMOKED  
**BONELESS HAM STEAK** **1<sup>79</sup>**

4 TO 6 LB. AVG. LB.

---

FRESH CUT, BEEF  
**BONELESS CUBED STEAK** **2<sup>29</sup>**

4 TO 6 LB. AVG. LB.

---

FRESH CUT, BEEF  
**BONELESS BOTTOM ROUND STEAK** **1<sup>99</sup>**

4 TO 6 LB. AVG. LB.

---

FRESH CUT, BEEF  
**BONELESS EYE OF ROUND STEAK** **2<sup>49</sup>**

4 TO 6 LB. AVG. LB.

world wide deli HOME OF VARIETY, FRESHNESS AND VALUE

NATURAL ALL WHITE MEAT  
**BREAST OF TURKEY** HALF POUND **1<sup>69</sup>**

HOME STYLE  
**COOKED SALAMI** HALF POUND **99<sup>c</sup>**

HYGRADE'S BALL PARK MEAT FRANKS LB. 1.69  
HYGRADE'S BALL PARK BEEF FRANKS LB. 1.79  
GREAT FOR SOUP  
**PORK BRISKET BONES** LB. **29<sup>c</sup>**

*Plum Crazy!*  
**CALIFORNIA PLUMS**

• RED • YELLOW • BLACK  
• BLUE • GREEN

Your Choice  
**58<sup>c</sup>**

LB.

FRESH  
**CRISP ROMAINE** LB. **38<sup>c</sup>**  
IDEAL FOR SUMMER DRINKS  
**FLORIDA LIMES** 12 FOR **69<sup>c</sup>**

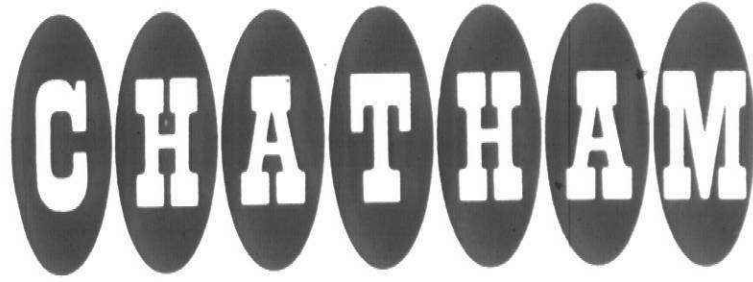

GOLDEN GRIDDLE  
**PANCAKE SYRUP**  
1-QUART 4-OZ. **1<sup>77</sup>**

HEAVY DUTY  
**CHATHAM FOIL**  
25 FT. ROLL **88<sup>c</sup>**

**SNOWY BLEACH**  
2-LB. 8-OZ. **2<sup>09</sup>**

**Folger's COFFEE**  
ALL GRINDS  
2 LB. CAN **5<sup>99</sup>**

**NEW HEAVY DUTY YES DETERGENT**  
64-OZ. **2<sup>99</sup>**

**CHATHAM BATHROOM TISSUE**  
4 ROLL PKG. **98<sup>c</sup>**

# Platform blues strike Michigan

By NICK SHARKEY and LYNN ORR

An unenthusiastic Michigan delegation swallowed the Republican platform Tuesday night, although some disregarded its importance to the fall campaign.

A controversial plank requiring judicial candidates seeking GOP endorsement to go on record as opposing abortion was one of the few items deleted from the platform to ease the strain on moderate Republicans who unsuccessfully fought for inclusion of support of the Equal Rights Amendment.

Congressman Carl Pursell of the 2nd District was one of those in the state delegation who attempted to downplay the platform. Although he supports the plank affirming a two-China policy with strong support for Taiwan, Pursell predicted that the platform wouldn't be crucial to the fall cam-

paign. He said Reagan will have to reach out to the pro-ERA people and others to unite the party.

"He's got to keep reaching out. He was meeting with the pro-ERA people today (Tuesday) and he's got to keep those communications open."

A few of the state delegates were delighted with the anti-abortion/ERA position, but the subdued majority clearly knew it had been beaten on the ERA issue by early that afternoon.

And the Hawaiian delegation's defeat to get the rules suspended to allow floor debate on the platform that night clearly ended any hopes for more moderate positions in the 78-page document.

AS DELEGATES filed into their caucus room at the airport Hilton that afternoon, many wore "ERA Now" buttons. It soon became apparent that they were unwilling to

wage a floor fight over the GOP platform's opposition to the Equal Rights Amendment that night.

Nancy Chase, a member of the GOP platform committee, told the Michigan delegation it would be almost impossible to change the platform. She said any amendment required 27 signatures from platform committee members.

According to Miss Chase, a majority from six states could call for a roll call vote on any proposal coming before the convention. But even then, a change would require support of two-thirds of the delegates.

"It will not happen," she successfully predicted. Former Michigan Sen. Robert Griffin urged the delegates not to wage a floor battle Tuesday night.

"If you'll remember, in 1976 there were many fights on Tuesday evening. This delayed the keynote speech until 1 a.m. Wednesday so it was not seen on prime time television."



Wild and crazy headgear was the dress of the week for many of the Republican delegates who found themselves with a lot of spare time to kill. New Jersey delegate Phil Matalucci sported this elephant head on top of his head for most of the convention. (Staff photo by Randy Borst)

## Zany costumes match moods of delegates

By MARY GNIEWEK

Republicans shed a stuffy image at their premiere party Monday at the Joe Louis Arena.

The Hawaiian delegation came in matching muumus and flowery shirts. Californians wore white Stetsons and Maine gleaned across the convention hall in bright yellow fishermen's rain hats. Rhode Island wore sailors caps.

Much of the crowd went crazy with headgear. Elephant hats topped more than a few heads and one delegate wore a hat with an inflatable pink elephant beating a set of drums.

A 10-gallon cowboy hat on a bald-domed delegate was smothered in Reagan slogans blaring from buttons and pins. Fuzzy knit berets and floppy cloth hats were similarly covered. One hat was topped with fake fruit a la Carmen Miranda.

Even traditional delegate hats with red, white and blue ribbon bands were personalized. A man in the Michigan delegation was spotted with three bites out of his rim. A woman covered the flat top of her hat with at least 30 tiny paper American flags on toothpicks and carried it in front of her.

Martian antennae bobbed up and down on some heads. One Hawaiian delegate wore a wreath of greenery in her hair.

No doubt who the Guam delegates were. Their clothing was emblazoned with "Guam" in letters to rival designer signatures on blue jeans.

A LOUISIANA woman topped off her outfit with a "Cajuns Love Reagan" T-shirt. Detroit police in London bobby uniforms posed for visitors' cameras. And Californians weren't the only ones with cowboy hats; they were predominant everywhere on the convention floor.

One alternate delegate stuck in the last row of her state's section peered at most of the proceedings through opera glasses. Across the aisle, a North Dakota delegate clipped a schedule of convention week events from a newspaper he was reading during the speech-making.

Robin Riddle, 17, a Utah alternate delegate, paced the arena aisle while Young Republicans spoke from the platform below.

"I've been involved in the party many years," she said. "This is my first convention. Next time I hope to be a delegate."

A man who emigrated from Czechoslovakia 12 years before Ms. Riddle was born was also at his first Republican National Convention. The man, Vaclav Hynar of Cleveland, participated in Sunday's captive nations march downtown.

"I LIKE Reagan's conservative way of thinking and strong hand in foreign affairs," he said.

"All my family is still in Czechoslovakia so I feel in touch with the situation there. Reagan will do something — spend more money on defense."

Antoinette Cristina walked around the convention hall to find a place where she could hear the main floor proceedings despite a faint sound system. A guest pass hung around her neck. Her husband was on the floor, a delegate from California.

"I've been to five conventions. My husband has been to more," said Mrs. Cristina, who lives in Santa Clara County.

"We knew Reagan when he was helping in the Goldwater campaign in 1964. We're longtime supporters," she gushed.

BILL RUNCO, a Michigan delegate who worked for George Bush in his 16th Congressional District (Dearborn), is slowly switching to John Anderson.

"Party politics is a lot of bull--," said Runco, a first-time conventioneer.

Others, like Bill Cobey, were lapping it up. Though Cobey was a long way from his Chapel Hill home, he took the convention as an opportunity to stump for his own campaign for lieutenant governor of North Carolina.

Cobey, 41, left his job as athletic director of the University of North Carolina in April to campaign fulltime. He was handing out literature Monday.

"This is my first convention," he said. "I'm going to enjoy it — soak it all in."

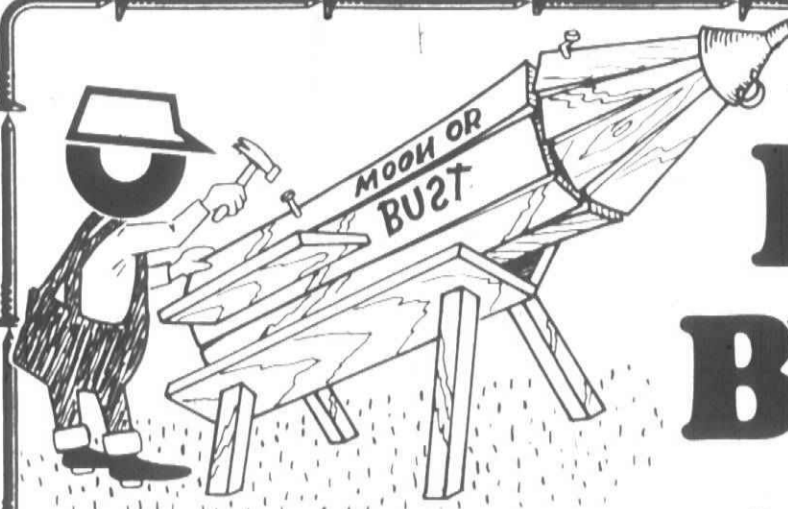

### 10x10 DECK PACKAGE

Deck Package includes all necessary Wolmanized lumber for beams, joists, fascia, and deck top, a 1010 metal component kit, cement, nails and 4 galv. pipes, ready for you to assemble at a fantastic savings. Benches, railings, and steps are optional. Design them to your own needs.

# EVERYTHING TO BUILD ANYTHING

## Kentile Vinyl Asbestos Floor Tile

Our Reg. \$20<sup>75</sup>

**\$6<sup>95</sup>** CTN  
45 Sq. Ft.



STUCCO BOARD BY ABITIBI  
4 x 8  
FACTORY PRIME  
**\$17<sup>95</sup>**

OWENS CORNING FIBERGLAS



## Insulation Super Specials

3 1/2" Kraft 6" Kraft 9" Kraft  
12¢ Sq. Ft. 20¢ Sq. Ft. 30¢ Sq. Ft.



Caribbean Paddle

## Ceiling Fan

30" **\$59<sup>95</sup>**

The energy saver that cools inflation  
Pre-wired, no other parts needed

## NOW! BOLD, DEEP WALL TEXTURES

Ruff-It by Z-BRICK



Easy to apply  
Premixed — ready to use  
Crack resistant — 6 colors  
Covers up to 80 sq. ft.

OUR REG. \$15.95 **\$10<sup>95</sup>**

2 GALLONS IN PLASTIC PAIL

## WOLMANIZED TREATED LUMBER

"IT'S THE IDEAL OUTDOOR WOOD"

LUMBER PRICES	8'	10'	12'	14'	16'	18'	20'
2x4 #2	2.32	2.87	3.56	4.16	4.98	5.26	5.84
2x6 #2	3.48	4.38	6.01	6.62	8.02	9.63	10.98
2x8 #2	4.45	5.75	7.68	8.31	9.94	10.60	13.63
2x10 #2	5.59	7.13	11.28	13.35	14.98	15.09	16.78
2x12 #2	9.17	11.91	14.73	16.80	20.28	24.26	27.68

## Have a problem wall?

### PARIS WALL COVERS IT ALL!

- The do-it-yourself "Wall-in-a-Roll" Paris Wall offers you these extras:
- Vinyl surface wipes clean in a jiffy.
  - Five patterns, 18 exciting colors.
  - Stain resistant.
  - Easier to install than wallpaper.
  - Provides insulation.
  - Aids in sound control.

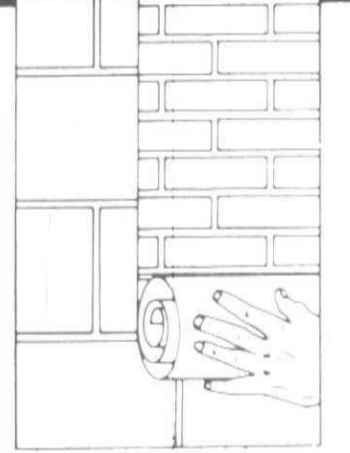

Over concrete block

Reg. 19.95 **\$17<sup>95</sup>**

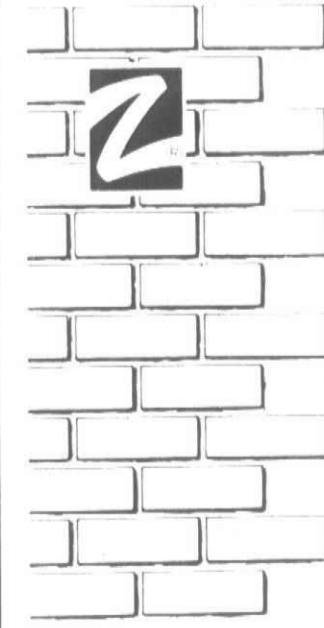

## Z-BRICK BRAND FACING BRICK

- Adding color and charm to any room in your home.
- Weatherproof — use it for siding or other outside jobs.
- Firesafe and non-toxic — can't burn.
- Guaranteed for 10 years.
- Inca Red only

**\$3<sup>29</sup>** Per Carton

4 Sq. Ft.

# HAGGERTY LUMBER & SUPPLY CO.

2055 HAGGERTY RD.  
(313) 624-4551 or (313) 356-6166

All Prices Cash & Carry Prices Good Thru 7-23-80

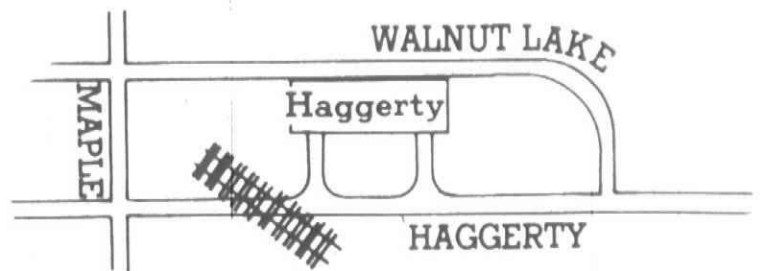

Howell Hours: M-Sat. 8-5 Sun. 10-3  
Walled Lake Hours: Mon.-Fri. 8-6 Sun. 10-3 Saturday 8-5

# CLASSIFIED REAL ESTATE

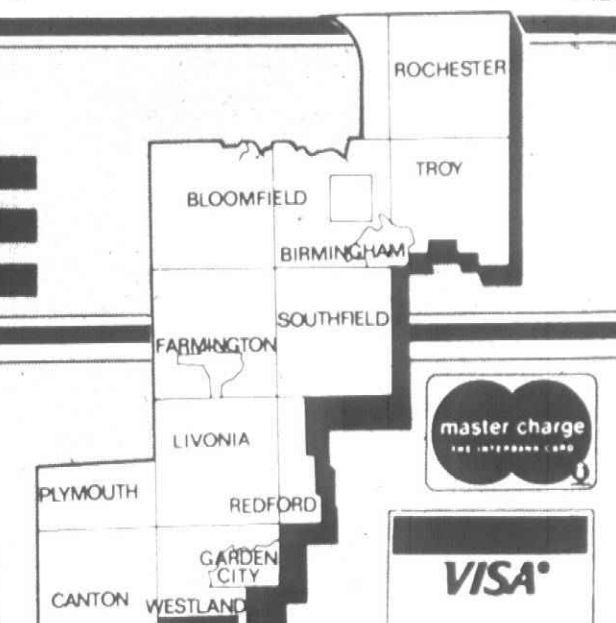

**ONE CALL DOES IT ALL!**  
Reach 12 communities with 1 call to  
**591-0900**

**EQUAL HOUSING OPPORTUNITY**

All real estate advertising in this newspaper is subject to the Federal Fair Housing Act of 1968 which makes it illegal to advertise any preference, limitation or discrimination on the basis of race, color, religion, sex or an intention to make any such preference, limitation or discrimination.

This newspaper will not knowingly accept any advertising for real estate which is in violation of the law. Our readers are hereby informed that all dwellings advertised in this newspaper are available on an equal opportunity basis.

**REAL ESTATE FOR SALE**

- 33 Birmingham Bloomfield
- 44 West Bloomfield
- 44 Farmington Hills
- 58 Brighton Farmstead
- 66 Southfield/Whitcomb
- 67 Midland-Highland
- 68 Dearborn/Troy
- 69 Royal Oak/Dix Park
- 70 Farmington Hills
- 71 Royal Oak/Lake
- 72 Farmington Hills
- 73 Canton
- 74 Dearborn
- 75 Dearborn Heights
- 76 Dearborn East
- 77 Westland/Farmington Hills
- 78 Dearborn
- 79 Farmington Hills
- 80 Wayne County
- 81 Dearborn
- 82 Dearborn East
- 83 Dearborn East
- 84 Dearborn East
- 85 Dearborn East
- 86 Dearborn East
- 87 Dearborn East
- 88 Dearborn East
- 89 Dearborn East
- 90 Dearborn East
- 91 Dearborn East
- 92 Dearborn East
- 93 Dearborn East
- 94 Dearborn East
- 95 Dearborn East
- 96 Dearborn East
- 97 Dearborn East
- 98 Dearborn East
- 99 Dearborn East

**REAL ESTATE FOR RENT**

- 400 Apartments to Rent
- 401 Apartments to Rent
- 402 Apartments to Rent
- 403 Apartments to Rent
- 404 Apartments to Rent
- 405 Apartments to Rent
- 406 Apartments to Rent
- 407 Apartments to Rent
- 408 Apartments to Rent
- 409 Apartments to Rent
- 410 Apartments to Rent
- 411 Apartments to Rent
- 412 Apartments to Rent
- 413 Apartments to Rent
- 414 Apartments to Rent
- 415 Apartments to Rent
- 416 Apartments to Rent
- 417 Apartments to Rent
- 418 Apartments to Rent
- 419 Apartments to Rent
- 420 Apartments to Rent

**NOTICES & SERVICES**

- 600 Personal (your discretion)
- 601 Lost Found
- 602 Cards of Thanks
- 603 Announcements
- 604 Legal Notices
- 605 Attorney Services
- 606 Transportation
- 607 Moving Services
- 608 Real Estate Wanted
- 609 Real Estate Wanted
- 610 Real Estate Wanted
- 611 Real Estate Wanted
- 612 Real Estate Wanted
- 613 Real Estate Wanted
- 614 Real Estate Wanted
- 615 Real Estate Wanted
- 616 Real Estate Wanted
- 617 Real Estate Wanted
- 618 Real Estate Wanted
- 619 Real Estate Wanted
- 620 Real Estate Wanted

**MERCHANDISE FOR SALE**

- Bus: 700 Auction Sales
- 701 Antiques
- 702 Antique
- 703 Antique
- 704 Antique
- 705 Antique
- 706 Antique
- 707 Antique
- 708 Antique
- 709 Antique
- 710 Antique
- 711 Antique
- 712 Antique
- 713 Antique
- 714 Antique
- 715 Antique
- 716 Antique
- 717 Antique
- 718 Antique
- 719 Antique
- 720 Antique

**AUTOMOTIVE**

- 800 Recreational Vehicles
- 801 Snowmobiles
- 802 Airplanes
- 803 Boats
- 804 Cars
- 805 Trucks
- 806 Trucks
- 807 Trucks
- 808 Trucks
- 809 Trucks
- 810 Trucks

**BUSINESS DIRECTORY**

- 3 Accounting Service
- 4 Advertising
- 5 Air Conditioning
- 6 Aluminum Cleaning
- 7 Aluminum Siding
- 8 Appliance Service
- 9 Asphalt
- 10 Bookkeeping
- 11 Business Office
- 12 Business Office
- 13 Business Office
- 14 Business Office
- 15 Business Office
- 16 Business Office
- 17 Business Office
- 18 Business Office
- 19 Business Office
- 20 Business Office

**EMERGENCY SERVICES**

- 211 Misc. For Sale
- 212 Wayne County
- 213 Bicycles For Sale
- 214 Bicycles For Sale
- 215 Bicycles For Sale
- 216 Bicycles For Sale
- 217 Bicycles For Sale
- 218 Bicycles For Sale
- 219 Bicycles For Sale
- 220 Bicycles For Sale
- 221 Bicycles For Sale
- 222 Bicycles For Sale
- 223 Bicycles For Sale
- 224 Bicycles For Sale
- 225 Bicycles For Sale
- 226 Bicycles For Sale
- 227 Bicycles For Sale
- 228 Bicycles For Sale
- 229 Bicycles For Sale
- 230 Bicycles For Sale

**COMMERCIAL**

- 231 Commercial Property
- 232 Commercial Property
- 233 Commercial Property
- 234 Commercial Property
- 235 Commercial Property
- 236 Commercial Property
- 237 Commercial Property
- 238 Commercial Property
- 239 Commercial Property
- 240 Commercial Property
- 241 Commercial Property
- 242 Commercial Property
- 243 Commercial Property
- 244 Commercial Property
- 245 Commercial Property
- 246 Commercial Property
- 247 Commercial Property
- 248 Commercial Property
- 249 Commercial Property
- 250 Commercial Property

**PLUMBING & HEATING**

- 251 Plumbing
- 252 Plumbing
- 253 Plumbing
- 254 Plumbing
- 255 Plumbing
- 256 Plumbing
- 257 Plumbing
- 258 Plumbing
- 259 Plumbing
- 260 Plumbing
- 261 Plumbing
- 262 Plumbing
- 263 Plumbing
- 264 Plumbing
- 265 Plumbing
- 266 Plumbing
- 267 Plumbing
- 268 Plumbing
- 269 Plumbing
- 270 Plumbing

ALL ADVERTISING PUBLISHED IN THE OBSERVER & ECCENTRIC IS SUBJECT TO THE CONDITIONS STATED IN THE APPLICABLE RATE CARD. COPIES OF WHICH ARE AVAILABLE FROM THE ADVERTISING DEPARTMENT, OBSERVER & ECCENTRIC NEWSPAPERS, 36251 SCHOOLCRAFT ROAD, LIVONIA, MICHIGAN 48150. (313) 591-2300. THE OBSERVER & ECCENTRIC RESERVES THE RIGHT NOT TO ACCEPT AN ADVERTISER'S ORDER. OBSERVER & ECCENTRIC AD-TAKERS HAVE NO AUTHORITY TO BIND THIS NEWSPAPER AND ONLY PUBLICATION OF AN ADVERTISEMENT SHALL CONSTITUTE FINAL ACCEPTANCE OF THE ADVERTISER'S ORDER.

**312 Livonia**

**A DAILY DIP**  
can be your routine while surrounded by privacy trees and landscaping. You'll enjoy the 16x32 pool in summer plus a sharp 3 bedroom brick ranch with central air. Full basement, 2 car garage. \$47,500

**EARL KEIM**  
SUBURBAN WEST, INC.  
261-1600  
15707 Farmington Livonia

**ALUMINUM TRIM BEST BUY!**  
Excellent split-level home in nice area. Featuring 3 large bedrooms, 1 1/2 baths, large family room and 2 1/2 car garage. Sharp decor shows pride of ownership. Gas furnace with central air and an electronic air cleaner. Call today, a super buy at \$52,900

**CENTURY 21**  
Hartford South 261-4200

**FAMILY ROOM-FIREPLACE**  
A fantastic buy! It's a tri-level with 3 large bedrooms, a 19 ft. kitchen, a den plus a family room with fireplace \$81,900

HARRY S.

**WOLFE COMPANY**  
32398 Five Mile 421-5660

**312 Livonia**

**A PLEASURE**  
to show! 3 bedroom brick ranch, full basement, large living room, newer furnace, central air, accommodations for wheel chair, 2 car garage. \$57,900. Ask for:

**NANCY AUSMAN**  
Century 21

**Gold House Realtors**  
459-6000

**BRICK RANCH**  
Super sharp 3 bedrooms, 1 1/2 baths, full finished basement with bar & carpeting, central air, 2 car garage, separate back yard with patio. Only \$58,900

**DEMBS SALES CO.**  
626-4884  
532-9485

BY OWNER 3 bedroom brick ranch, large family room, garage. Nice decor, new carpeting, fenced yard, extras. \$53,900 525-2766

BY OWNER 36301 W 6 Mile, 3 bed room ranch, 1st floor laundry, rec room, wet bar, central air, sprinkler system, 2 car attached garage-opener. Assm. ables 9 1/4 % - \$77,500. 464-7088

**CANTON**  
Brick ranch, 2 bedrooms, 1 1/2 baths, family room, full basement, 2 car attached garage. Call 455-8219

**312 Livonia**

**FEELING HEMMED IN?**  
You will not be in this corner lot 4 bedroom colonial with it's formal dining room, 1st floor laundry and 2 family rooms. Impressively rich in natural wood decor. \$87,500. Open Sat. and Sun. 16975 Fitzgerald.

**FAST FADING FIFTIES**  
Well cared for 3 bedroom, 1 1/2 bath brick ranch with finished basement, patio, garage and more for only \$58,000

**CENTURY 21**  
CORNERSTONE 478-4660

**FLORIDA ROOM**  
Highlights this lovely 3 bedroom brick ranch in quiet West Livonia sub. Spotless country ranch with country kitchen, basement and attached garage. Many flowering trees. See it now in all it's glory! \$59,900

**CENTURY 21**  
Hartford South 261-4200

**COUNTRY SETTING**  
3 bedroom brick ranch, oversize lot backs to woods, rec room with bar & fireplace, 2 1/2 car garage, many extras. Open Sunday 1-5pm. \$71,000. 464-6035

**COUNTRY (1 ACRE)**  
One acre of treed beauty surrounds this 3 bedroom, 1 1/2 story home. Multiple baths, 2 car garage and much, much more. Call today

**ERA**  
FIRST FEDERAL 478-3400

**312 Livonia**

**LC TERMS**  
Livonia's Best Buy on this sharp 4 bedroom brick Colonial in Kimberly Oaks, family room with fireplace. Well planned kitchen with built-ins, extra insulation. Owner anxious! \$79,900

**REALTY WORLD**  
JERRY F. EDWARDS & ASSOC  
553-8100

**LIVONIA "A STEAL"**  
**MUST SELL!**  
3 bedroom brick ranch. BEAUTIFUL finished basement, 2 1/2 car garage with opener, CENTRAL AIR, hardwood floors and much, much more! Walk to shopping, VA, PMA. Asking \$51,500. Call John Maxwell, 261-1400

**RE/MAX WEST, INC.**  
CLOSE TO EVERYTHING  
It's a large brick ranch featuring 3 nice size bedrooms, a huge living room with a dining "L". Modern kitchen, finished basement and oversized 2 car garage. \$52,900

HARRY S.

**WOLFE COMPANY**  
32398 Five Mile 421-5660

**Country Casual**  
Sharp 2 bedroom, possible 3rd bedroom, frame bungalow. New carpeting throughout, remodeled kitchen, large ravine lot, wooden balcony off dining room. Just reduced. Land contract terms available. Asking \$47,900

**CENTURY 21**  
TODAY 525-7700

**312 Livonia**

**Country Living**  
Remodeled farm house on 2.5 acres ad. 3 bedrooms, 2 1/2 baths, finished basement and 2 car garage. \$79,500

**CENTURY 21**  
TODAY 478-1040

**HOT NEW LISTING**  
Super price and terms on this sharp 3 bedroom brick ranch home. Featuring family room, modern kitchen, finished basement with 1/2 bath central air, and 2 1/2 car garage. Land Contract \$59,900

HARRY S.

**WOLFE COMPANY**  
32325 Seven Mile 474-5700

**INGROUND POOL**  
3 1/4 bedroom brick tri-level, 1 1/2 baths, built-ins, self-cleaning oven, new Solarian floor, all new carpet, drapes included, huge treed lot, complete privacy. 16 X 32 ft. inground heated pool & new pool house. Livonia's best area \$74,000. 14803 Ellen Dr. 464-7244

**JUST LISTED**  
\$61,500 MUST BE SOLD  
3 Bedroom Ranch 2 1/2 master bedroom. Natural fireplace. Central air, full finished basement. 2 car garage. A MUST TO SEE.  
Jerry Borregard 477-1800

**CHALET COLLEGE**  
FOUR BEDROOM COLLEGE, 2 1/2 bath, remodeled kitchen & family room, 1st floor laundry, accepting offers in the \$90's 464-9013

**312 Livonia**

**CARDINAL LIVONIA & AREA**  
**CLOSE TO PARK**  
Sharp 3 bedroom brick ranch, built-in dishwasher, new cabinets, rec room, central air, garage. All for \$54,900

**NOTTINGHAM WEST**  
Charming 4 or 5 bedroom Colonial on large landscaped lot. 2 1/2 baths, family room with fireplace, rec room, finished kitchen built-ins, attached 2 car garage. Much more! \$117,900

**FARM BOYS DELIGHT**  
Harvest your own garden on this 3 1/2 acre lot when you buy this sharp 3 bedroom 1976 ranch. Tastefully finished hardwood basement, garage with drive thru doors & 2nd floor laundry.

**RENT WITH OPTION**  
To Buy Check out this 3 bedroom Colonial in earth tone decor 1 1/2 baths, landscaped with attractive patio in mint condition \$85,500

**LOW RATE FINANCING**  
Available! Lovely 3 bedroom Colonial with 2 1/2 baths, family room with fireplace, 2 car garage. Lovely Northville area \$78,900

**BETTER THAN NEW!**  
Handyman - don't bother to look, as this 3 bedroom brick & aluminum ranch has been completely redecorated inside and out. Newly landscaped lot also 2 car garage. Hurry for this squeaky clean doll house Only \$48,900

**GREEN CASTLE**  
Is location of this maintenance free 3 bedroom, 1 1/2 bath ranch, surrounded by pines and mature landscaping on lovely 1/4 acre lot! Country kitchen, basement, attached garage. Consider land contract. \$74,900

**COUNTRY LIVING**  
Over 1,800 sq ft in this custom built ranch on 1 1/2 acres! Features a formal dining room, 2 full baths, fireplace, 2 car garage and more. Asking \$78,900

**Cardinal West, Inc.** 522-5333

**312 Livonia**

**KIMBERLY OAKS**  
Striking 4 bedroom (in-law unit), 1 1/2 baths, brick & aluminum quad. Family room, fireplace, newer carpeting throughout, built-in, rec room, finished attached 2 car garage and work shop ext. 75 lot. Land Contract terms. Quick possession. Compare at \$85,900

**EARL KEIM**  
SUBURBAN WEST, INC.  
261-1600  
15707 Farmington Livonia

**CASTLE GARDENS**  
An unusual floor plan in this clean, 3 bedroom brick ranch with a super kitchen, family room, fireplace, 1 1/2 baths, finished basement and attached garage. \$86,900

HARRY S.

**WOLFE COMPANY**  
32398 Five Mile 421-5660

**FIRST OFFERING**  
Super sharp 4 bedroom brick colonial, dining room, large family room with fireplace, 2 1/2 baths, 1st floor utility, large master bedroom, pool in perfect condition, approximately 2400 sq ft. Great Livonia area with many trees. \$110,000

**Rizzo Realty, Inc.**  
GALLERY OF HOMES  
349-1515

**312 Livonia**

**LIVONIA BUILDERS SPEC.**  
**SAVE \$8,500**  
10 1/4-30 YR MORTGAGE

**EARL KEIM**  
SUBURBAN WEST, INC.  
261-1600  
15707 Farmington Livonia

**HUNTLEY HOMES INC.**  
478-6293 851-3800

**LIVONIA Country Home Estates**  
By Owner Sharp 4 bedroom colonial, family room with fireplace, 1 1/2 baths, dining room, 1800 sq ft newly decorated close to expressways and shopping. \$79,900. 36956 Five Mile. 464-7660

**LIVONIA - 1 ACRE**  
30230 Puritan  
**OPEN HOUSE SUN. 2-5 PM.**  
Roomy 3 bedroom ranch, family room, attached 2 car garage, circular drive. \$97,500. Land contract terms available. Call

**MURRINGHAM ASSOCIATES**  
261-9610

**LIVONIA, 1978 Merriman Ct. S. of 7 Mile, 1 block E. of Merriman**  
Charming 2 bedroom Cape Cod, with fireplace, on fenced acre, 1 car garage, low taxes \$46,900. Owner 476-3792

**312 Livonia**

**8 3/4% Land Contract**  
4 bedroom, 2 1/2 baths, huge family room, fireplace, completely carpeted, 2 1/2 car garage, are a few of the features in this outstanding home. A super buy at only \$107,990

**BROKER**  
626-4884  
532-9485

**MIRRORS, MIRRORS**  
on the walls, accent the beauty and spaciousness of this 10 room 1978 colonial. 1st floor laundry, central air, 2 1/2 baths underground sprinkler system and more. Must see \$115,900

**EARL KEIM**  
SUBURBAN WEST, INC.  
261-1600  
15707 Farmington Livonia

**NEW BIRTH & 6 MILE**  
Roomy colonial with 1st floor laundry and covered patio. Owner transferred. All offers considered.

**CHALET**  
477-1800

**NEW HOMES**  
Livonia-Redford  
3 bedroom ranch, garage, some with basement. MSUDA financing available or 5% down conventional. Priced from \$41,900

**NEW WORLD SUMMIT**  
427-3200

**OWNER TRANSFERRED**, immediate occupancy. 1,500 sq ft. 3 bedroom all brick Tri-Level, 2 baths, fireplace in family room, fruit trees, 2 1/2 car garage, quiet winding street, close to schools. \$71,900

**Chamberlain REALTORS**

**CANTON**  
OPEN SUNDAY 2-5 42234 Ashbury, N. of Hanford, E. of Lilley. Diane Kecskas will be there to show you this lovely Quad with simple assumption at 10 1/4 % PA3 455-5200

**SOUTH REDFORD**  
Beautiful treed setting and lots of flowering shrubs. Brick ranch, 3 bedrooms, 1 1/2 baths, natural fireplace, family room, full tiled basement, attached garage. \$72,900 WG2 721-8400

**DEARBORN HEIGHTS**  
Beautiful brick ranch in Golfview Manor Sub featuring 3 bedrooms, 1 1/2 baths, finished basement, paneled and insulated 2 car garage and brick patio. \$60,500 WA2 721-8400

**GARDEN CITY**  
Very spacious broadfront 3 bedroom ranch featuring beautiful family room with fireplace, dining room, carpet throughout, attached garage and immediate occupancy. \$51,900 WJ5 721-8400

**WESTLAND**  
Prime Area! Beautiful brick ranch featuring 3 bedrooms, 1 1/2 baths, large kitchen, full finished basement, garage and patio with barbecue. \$52,900 WW1 721-8400

**WESTLAND**  
Well maintained ranch with excellent floor plan for professional use. Gorgous trees, circle drive. Featuring 3 bedrooms, natural fireplace, den, family room, partial basement, garage. \$89,900 WF2 721-8400

**WESTLAND**  
Gorgeous home featuring 3 bedrooms, family room, natural brick fireplace, 1 1/2 baths, kitchen appliances, 2 car garage and covered patio. \$65,900 WH3 721-8400

**CANTON**  
PRICED TO SELL! This great Quad features: 4 bedrooms, 2 1/2 baths, family room with fireplace, dining room, carpet throughout and more. Call Darrell Phelps for more information. PC23 455-5200

**CANTON**  
FORMER MODEL tastefully decorated and well maintained with 3 bedrooms, family room with fireplace, carpet throughout, patio and 2 1/2 car garage. Ask for Dick Randazzo. PC24 455-5200

**PRIME LAKEFRONT PROPERTY**  
Immaculate custom built home offers many quality features. Excellent location on lake. Call 476-9100

**LIVONIA**  
is beautiful. Blue Grass Farms, spacious maintenance free split level with partially finished recreation room, formal dining room, family room fireplace, 2 car attached garage and pool. Priced to sell \$89,900. 476-9100 LL6

**REDFORD**  
Sharp 3 bedroom aluminum home with full basement and a 1 1/2 car garage. Immaculate condition. 476-9100

**LIVONIA**  
Sharp 3 bedroom ranch with 2 1/2 car garage. Furnace is brand new. This one won't last at only \$38,900. Ask for Larry Buckmaster. 476-9100

**FARMINGTON HILLS**  
Over 1/2 acre and country atmosphere surround this 2 bedroom starter home with 2 car garage. \$29,900. 476-9100

**LIVONIA**  
3 bedroom brick ranch. Basement, family room with fireplace, large garage on 1/2 acre lot. Any Terms. \$62,900. Ask for Gene Albright.

**OPEN SUNDAY 2-5**  
7219 Willow Creek (N. of Ford, W. of Lilley)  
BEAUTIFUL QUAD on a corner lot with many extras. 4 bedrooms, 2 1/2 baths, family room with fireplace and wet bar, immediate occupancy and so much more. Stop by Sunday and see Esta Chebatt for more information. PW11 455-5200

**ERA FIRST FEDERAL**  
478-3400

**COUNTRY-LIKE** Setting sharp 3 year old 3 bedroom brick ranch, family room fireplace, 1 1/2 baths, 2 car attached garage with opener, covered patio. \$73,900 427-3631

**BUYERS TAKE NOTE!** First offering on this (1 1/2 Year New) value packed colonial with 3 bedrooms, 1 1/2 baths, first floor laundry, family room with fireplace, backs to commons and more. Ask for Lisa Palmer. PC22 455-5200

**BUYERS TAKE NOTE!** See the real time farm, (approximately 1 1/2 acres). Located in Canton Township. Close to schools and town activity but nestled quietly among gracious country homes. Vegetable garden of 1/2 acre is already planted. This 3 bedroom, 1 1/2 bath broad front brick ranch has living room fireplace, formal dining room, big family room, sewing room, gas heat, 2 car garage. Heated work building with attached greenhouse. Only \$105,000

**WALK TO EVERYTHING!**  
Five bedroom brick Cape Cod in the City of Plymouth. Custom built, wet plaster, 2 1/2 baths. Comfortable living room with fireplace, invites family gathering. formal dining room. Finished basement makes this an ideal home for the busy growing family. \$89,900

**LOVE THE COUNTRY?**  
Want to grow your own food? See the real time farm, (approximately 1 1/2 acres). Located in Canton Township. Close to schools and town activity but nestled quietly among gracious country homes. Vegetable garden of 1/2 acre is already planted. This 3 bedroom, 1 1/2 bath broad front brick ranch has living room fireplace, formal dining room, big family room, sewing room, gas heat, 2 car garage. Heated work building with attached greenhouse. Only \$105,000

**HITCHCOCK Gallery of Homes**  
607 S. MAIN ST.  
PLYMOUTH  
**453-2210**

**OPEN SUNDAY 2 TO 5**  
**CONNEMARA HILLS**  
NORTHVILLE/NOVI AREA  
Come and see what makes Connemara Hills special. Gently rolling hills, beautiful treed 1/2 acre lots and fine custom-built homes. South of 9 Mile Rd. East of Tait

**DECORATOR'S DREAM**  
Uniquely designed contemporary beauty 4 bedrooms, 2 1/2 baths and separate formal dining room, provide the basics with cathedral ceilings, skylight and doorways providing the dramatics 217-10 Rathlone. \$104,900  
REALTOR 349-5600

**LARGE FAMILY**  
Spacious 4 bedroom, 3 bath hillside ranch with walk-out basement. Central air, hardwood floors, wood windows and storage galore. Beautiful kitchen with huge pantry and all appliances. 45294 Byrne. \$129,900  
REALTOR 349-5600

**SIZZLER SPECIAL**  
Air conditioned, 4 bedrooms, 2 1/2 baths, living room, dining room, family room with natural fireplace, redwood deck, 1/2 acre lot. Land Contract or assumption. Great Value. 22000 Tait Road. \$90,500  
REALTOR 349-4030

**IMMEDIATE OCCUPANCY**  
on this lovely Spanish ranch with 3 bedrooms, first floor laundry, formal dining room. Also large wood deck off family room and partially finished basement with bar 21740 Kilrush \$99,900  
REALTOR 851-5500

**RUSTIC AND COMFY**  
Running stream for Northern Michigan atmosphere, walk-out lower level, billiard room, 3 bedrooms, 2 1/2 baths, formal dining room, natural fireplace and attached garage. 44920 Byrne. \$133,700  
REALTOR 261-1400

**BY OWNER LISTINGS FOR BUYERS and SELLERS (NO COMMISSIONS OR CONTRACTS)**

M623 Northville, 3 bedroom, 1 1/2 baths, Condo, 7 3/4 %  
R514 Bloomfield, 3 bedrooms, 2 baths, 1 1/2 acre, L.C.  
E605 Birmingham, 4 bedrooms, 2 1/2 baths, 3500 sq. ft. L.C.  
K615 Oak Park, 3 bedrooms, 1 1/2 baths, finished basement.

**SHARE ADVERTISING INC.**

864 S ADAMS BIRMINGHAM 642-1620

**OPEN SUNDAY, 15949 WHITBY, Livonia, great Coventry Gardens location, very sharp 3 bedroom ranch with 2 1/2 baths, dining room, fully carpeted, fireplace, recreation room, patio, CENTRAL AIR, oversize garage, \$74,900.**

**OPEN SUNDAY, 2-5 P.M. 15105 WOOD-WORTH, Redford, newly and tastefully decorated and carpeted, 3 or 4 bedroom bungalow in Western Golf area, family room, fireplace, recreation room, built-ins, 2 car attached garage, \$79,900.**

**OPEN SUNDAY, 7646 TERRI, Westland, Immediate Occupancy, spectacular entertainment facilities come with this 3 bedroom ranch home, beautifully decorated, carpeted and draped, built-ins, gorgeous privacy yard, 2 car garage, \$65,000.**

**312 Livonia**

**WOLFE**  
COMPANY 421-5660  
32398 Five Mile

**CASTLE GARDENS**  
An unusual floor plan in this clean, 3 bedroom brick ranch with a super kitchen, family room, fireplace, 1 1/2 baths, finished basement and attached garage. \$86,900

HARRY S.

**WOLFE COMPANY**  
32398 Five Mile 421-5660

**OPEN SUNDAY 2-5 42234 Ashbury, N. of Hanford, E. of Lilley. Diane Kecskas will be there to show you this lovely Quad with simple assumption at 10 1/4 % PA3 455-5200**

**Beautiful treed setting and lots of flowering shrubs. Brick ranch, 3 bedrooms, 1 1/2 baths, natural fireplace, family room, full tiled basement, attached garage. \$72,900 WG2 721-8400**

**Beautiful brick ranch in Golfview Manor Sub featuring 3 bedrooms, 1 1/2 baths, finished basement, paneled and insulated 2 car garage and brick patio. \$60,500 WA2 721-8400**

**Very spacious broadfront 3 bedroom ranch featuring beautiful family room with fireplace, dining room, carpet throughout, attached garage and immediate occupancy. \$51,900 WJ5 721-8400**

**Prime Area! Beautiful brick ranch featuring 3 bedrooms, 1 1/2 baths, large kitchen, full finished basement, garage and patio with barbecue. \$52,900 WW1 721-8400**

**Well maintained ranch with excellent floor plan for professional use. Gorgous trees, circle drive. Featuring 3 bedrooms, natural fireplace, den, family room, partial basement, garage. \$89,900 WF2 721-8400**

**Gorgeous home featuring 3 bedrooms, family room, natural brick fireplace, 1 1/2 baths, kitchen appliances, 2 car garage and covered patio. \$65,900 WH3 721-8400**

**PLYMOUTH/NORTHVILLE 455-5200**     **WESTLAND/CANTON 721-8400**     **LIVONIA/FARMINGTON 476-9100**

**BRIGHTON/LIVINGSTON 478-7560**     **National Relocation Counseling Center**     **ALLEN PARK/DEARBORN 388-2200**

**Martin, Ketchum & Martin REALTORS**     **522-0200**     3172 FIVE MILE ROAD at Merriman, Livonia

**312 Livonia**

OPEN SUN 12 to 4PM  
BY OWNER - 3 bedroom Ranch, family room fireplace, 1 1/2 baths, attached garage, extras \$67,900 591-2183

**STARTER**  
37,900!!

Excellent starter home and priced for quick sale. 3 bedroom brick front ranch in area of comparable homes for more 1000 sq. ft. with country kitchen and 2 car garage. Immediate occupancy. Move fast!

**CENTURY 21**  
Hartford South 261-4200

**THEIR LOSS**  
is your gain. A drastic reduction on this 3000 sq. ft. quad-level in prestigious Kimberly Oaks. 5 bedrooms, 3 full baths, family room/fireplace, 2 car attached garage \$89,900

Century 21  
Gold House Realtors  
459-6000

**312 Livonia**

SIMPLE ASSUMPTION  
Excellent starter home for young couple 2 bedroom aluminum ranch, full basement, priced reduced for quick sale.

SUBURBAN GALLERY OF HOMES  
277-2700

Simple Assumption available or land contract terms on this exquisite home on a 1/2 acre lot. Gleaming hardwood floors highlight several rooms, new plush carpeting, stone fireplace in living room, formal dining, 3 bedrooms, library or den, sun-room, basement, garage and immediate occupancy. Priced at \$65,000. Call: KAREN BAUGHAN CENTURY 21 Gold House Realtors 420-2100

**312 Livonia**

"PRIME AREA" REDUCED  
Estate size lot with sharp and clean ranch style home featuring 3 bedrooms, formal dining room, family room with fireplace, in-ground pool, fruit trees and more. Only \$49,900.

**CENTURY 21**  
TODAY 538-2000

OLDE ROSEDALE  
2 natural fireplaces, vaulted ceilings highlight this 3 bedroom brick ranch, formal dining, finished basement, remodeled kitchen, wood deck, garage. Land Contract with \$25,000 down, \$69,900 call 459-3700

Realty World  
CHAPMAN WEST

RAVINE LOT  
Split rail fence, 4 bedrooms, 2 1/2 baths, central air, fireplace, simple assumption at 9 1/2% \$99,900

MASTER ASSOCIATES  
478-7550

**312 Livonia**

PICTURE PERFECT  
Stunning 4 bedroom, 2 1/2 bath home in a wooded setting. Featuring family room with fireplace, dining room, country size kitchen, 1st floor laundry, full basement, 3 car attached garage and superb decor and landscaping. \$123,900. HARRY S.

**WOLFE**  
COMPANY 474-5700  
33235 Seven Mile

PRICE BUSTER  
Nice 3 bedroom brick and aluminum sided ranch home. Featuring a spacious modern kitchen, full finished basement, central air, and a 2 car heated garage on large lot. \$49,900. HARRY S.

**WOLFE**  
COMPANY 474-5700  
33235 Seven Mile

PRICED BELOW MARKET  
Looking for a quick sale on this 3 bed room brick ranch with 1 1/2 baths, basement and garage. \$49,900.

ASK FOR RUDY RESTUM

\$13,150 ASSUMES  
10 1/2% mortgage on custom, spacious 3 bedroom brick ranch with all the extras including finished basement, large family room with fireplace, attached 2 1/2 car garage.

ASK FOR LLOYD LEATHERMAN

**CENTURY 21**  
Restum Realty 353-6666

**312 Livonia**

REDUCED \$7000  
LOVELY CIRCULAR STAIRCASE  
One of many features in this 2500 sq. ft. Brick Colonial in Goldview Meadows. 4 bedrooms, 2 full and 2 half baths, balcony with doorwall off Master bedroom suite. Finished basement, 2 large patio, 2 car garage and more.

WORDS WON'T DO IT  
SPACIOUS & FRESHLY decorated Brick Colonial in Gold Manor Sub. It offers 4 bedrooms, 2 1/2 baths, Large Family room with fireplace plus a Den or 5th bedroom. Formal dining room, CENTRAL AIR, Large private patio, 2 car attached garage and all covered with "HOME WARRANTY". Fast Occupancy.

**EARL KEIM**  
538-8300  
REDFORD INC.

RUSTIC 3 bedroom ranch with privacy on nearly 1/2 acre lot. Many trees, beautifully finished basement and garage. \$49,900.

CHAMBERLAIN  
476-9100

SHOW PLACE  
The most attractive 3 bedroom colonial you will ever see! Brick with anchor front 1 1/2 baths with pass thru to master bath from master bedroom. A formal dining room, great country kitchen overlooking a cozy family room with fireplace. Full basement and a 2 car garage. \$84,900. HARRY S.

**WOLFE**  
COMPANY 421-5660  
32398 Five Mile

1 1/2 ACRE  
A better value in Livonia! 3 bedroom brick ranch, 1 1/2 baths, finished rec room in basement, newer furnace, please call today. Only \$55,750.

**EARL KEIM**  
SUBURBAN WEST, INC.  
261-1600  
15707 Farmington Livonia

**312 Livonia**

Trees Trees Trees  
Located on a lovely tree lot is this spectacular 3 bedroom ranch, offering a cozy family room, fireplace and attached garage. Only \$50,500.

**Century 21**  
Hartford South 464-6400

YOUNG AT HEART  
Excellent location in the center of Livonia, a shaded street and a country atmosphere. Charming 3 bedroom bungalow, nicely decorated and well cared for, complete with a 2 car garage. Asking \$47,500. HARRY S.

**WOLFE**  
COMPANY 421-5660  
32398 Five Mile

YOUR COUNTRY ESTATE  
5 Bedroom Dutch colonial, 2 1/2 baths, huge kitchen, formal dining room, 2 fireplaces, full basement, in-ground 48 x 30 pool on acre lot. Asking \$61,500. See, Make Offer, Your Terms.

SAYLOR REALTY  
427-1700

**312 Livonia**

16" IN CEILING INSULATION  
Keeps this lovely 3 bedroom brick ranch with large rooms extra cool. 2 car attached garage, basement, nice lot, etc. GI 180 down or easy conventional terms. Century 21, ABC. 425-3250

10% MORTGAGE AVAILABLE  
IF you make over \$22,000 annually and have \$7000 or more to put down as down payment, 3 bedrooms 1 1/2 bath ranch with full basement, 1100 sq. ft. Corner lot, carpet & tile your choice with \$1000 allowance. \$51,000. LCA BUILDING CO. 525-9035

19646 DONNA, Open Sunday 2-5. Beautiful 3 bedroom brick ranch, must see. Excellent floor plan, large 19 ft kitchen with built-ins, doorwall to covered patio, recreation room, central air, land contract terms. \$59,900. FOUR SEASONS REALTY 562-8444

5 BEDROOM BARGAIN  
(1-m). Best buy in Livonia 5 bedrooms, 2 1/2 bath colonial situated on extra large, beautifully landscaped lot in prestigious area. Close to schools, shopping, expressway and neighborhood swim club. Mortgage assumption possible. Now only \$99,500. MI. 65230. Call 981-2900.

**Century 21**  
VINCENT N LEE  
EXECUTIVE TRANSFER SALES  
851-4100

**314 Plymouth-Canton**

BE A WINNER!  
You won't find a better value or investment than this beautiful 3 bedroom colonial, newer central air, basement under family room, large patio, 2 car attached garage. \$69,900.

Century 21  
Gold House Realtors  
459-6000

BY OWNER - 4 bedroom brick colonial, 2 1/2 baths, family room, natural fireplace, formal dining room, first floor utility patio, fenced yard, backing up to 4 acre park. \$86,500. 455-8963

Absolute Delights  
SPARKLING CLEAN 3 bedroom fully carpeted brick ranch in a popular SPANAR location. Sunken mirrored family room, finished basement with bar and over 2 1/2 car garage. Just listed at only \$63,900 with a great assumption. Call 981-2900

EASY ASSUMPTION available on this beautiful central air conditioned former model brick ranch, up-graded carpeting, crown moldings, custom window treatments, sunken family room with natural fireplace and attached 2 car garage. Just \$77,500 with fast occupancy. Call 981-2900.

LARGE FAMILY! LOW BUDGET? Explore this central air conditioned 4 bedroom fully carpeted duplex with 2 full baths, sunken family room and attached 2 car garage. Newly offered with fast occupancy at just \$53,900. Call 981-2900.

CAPE COD with 4 spacious bedrooms, 2 full baths, full basement, sunken family room and attached 2 car garage, backs up to beautiful tree park. Only \$71,900. Call 981-2900.

SUNFLOWER VILLAGE boasts of this huge professionally landscaped 4 bedroom fully carpeted colonial with 2 1/2 baths, 1st floor laundry, sunken family room with natural fireplace and wet bar, private study and attached 2 car garage. Newly listed at only \$93,900. Call 981-2900.

CHILLING CENTRAL AIR cools this gorgeous completely up graded colonial on a meticulously landscaped court lot 19 ft. family room with natural fireplace, 1 1/2 baths, full basement, custom room with gas grill and 2 car attached garage. Asking only 476,900. Call 981-2900.

FENCED PASTURE and 2 stall barn with tack room included with this custom built 3 bedroom fully carpeted brick ranch, 2 natural fireplaces, large country kitchen and attached 2 car garage. Asking only \$87,400. Call 981-2900.

COUNTRY CUTIE! 2 1/2 beautiful manicured acres included with this lushly carpeted 3 bedroom aluminum starter bungalow, modern kitchen with built-in and natural fireplace, 2 car garage and more. Only \$47,900 with fast occupancy. Call 981-2900.

**Century 21**  
Hartford 429, Inc. 981-2900

**314 Plymouth-Canton**

ASSUMPTION  
Newer 3 bedroom brick ranch on quiet street, protected by Home Owner's Warranty. Finished office room in basement, patio deck off family room with fireplace, 2 car attached garage. \$66,900.

Century 21  
Gold House Realtors  
459-6000

Assumption 7 3/4, 742 Princess, 4 bedroom colonial, finished basement, family room with fireplace, garage, central air, patio. L.C. available. \$77,900.

CAMBRIDGE  
459-4620

Bargain Hunters  
Exceptionally clean 3 bedroom colonial with a full brick wall fireplace in family room. Must See! Priced below market value at \$69,900. Ask for:

LINDA WATERWORTH  
Century 21  
Gold House Realtors  
459-6000

BARGAIN PRICE  
\$71,500  
Clean spacious 1800 sq. ft., 4 bedroom colonial in Canton's most desirable area, formal dining room & large eating area in kitchen, 2 1/2 baths plus main floor.

Red Carpet  
RICHTER & ASSOC. 522-3500

BY OWNER - 4 bedroom quad 3 baths, thermo windows, air, huge family room. Must Sell LC possible. Immediate Occupancy. 455-3348

BY OWNER - 3 bedroom ranch, family room with fireplace, 1 bath, tastefully decorated, Willow Creek Sub., \$62,500. Land Contract available. 455-6322

CANTON ASSUMPTION  
\$4,900  
IMMEDIATE OCCUPANCY

3 bedroom brick and aluminum colonial, family room, 2 car attached garage, 3 year old home, basement. Owner anxious to sell.

Manley, Markey, & Gayle  
535-0066

CANTON BY OWNER, Tudor, 4 bedrooms, 2 1/2 baths, custom features throughout, greenhouse window, underground sprinklers, central air, large lot, more. \$97,900. Call after 6 PM. 453-1488

CANTON TWP. ATTENTION REALTORS  
\$5,000 DOWN  
\$695 MONTH  
1 QUAD \* 1 COLONIAL  
Immediate Occupancy  
New Construction  
2 year Land Contract, 2000 sq. ft., 4 bedrooms, 2 1/2 baths, family room with fireplace, full basement, 2 car attached garage, brick four sides, completely carpeted, HOW Warranty Call 455-9080 after 1 PM or 626-1233.

DEMBS BLDG. CO.  
CANTON TWP.  
\$5,100  
Moves you in immediately into a brick Colonial or Quad Level. \$895/month. 3 year 11% Land Contract. Both homes feature 4 bedrooms, attached garage, family room with fireplace, 2 1/2 baths, carpeting. \$86,990.  
348-7410  
685-8280  
DEMBS BLDG. CO.  
CANTON, 3 bedroom ranch with family room, large lot, many extras. 9 rooms old, unbelievable assumption. 397,8641  
348-7410  
CANTON, 3 bedroom ranch, 1 1/2 baths, large family room, 2 car attached garage, \$74,000. 455-6343

**SOLD** **SOLD** **SOLD** **SOLD**



**Simple Assumption**  
Excellent value on this 3 bedroom, 1 1/2 bath brick colonial on a favorable premium lot backing to a commons area. Well planned efficiency in its country kitchen, family room with beautiful natural fireplace, master bedroom with walk-in closet, full basement, doorwall leading to the expansive patio, nicely landscaped and an attached 2 car garage. Just \$77,900. Call 453-7600.

**Room-A-Tism?**  
Try this huge 2300 sq. ft., 4 bedroom, 2 1/2 bath brick colonial on a premium lot location backing to a wooded commons area. The family room has a wood burning fireplace and a wet bar, first floor laundry, recreation room in basement, extensive insulation and very low utility bills, carpeting throughout, crown moldings, automatic sprinkler system, attached 2 car garage. Only \$90,900. Call 453-7600.

standing fireplace, a full basement, and very close to schools and major shopping areas. Asking just \$65,900. 453-7600

**Beacon Hill**  
Delightfully captivating 3000 sq. ft., 4 bedroom colonial on a private cul-de-sac lot. Decorated in earth tones with upgraded carpeting, natural fireplace and wet bar in the family room, cozy den, oversized country kitchen with custom cabinets, Jennaire range and double self-cleaning ovens, first floor laundry, full basement, central air, underground sprinkler system, attached 2 car garage, possible land contract terms. Only \$169,900. Call 453-7600

**Awaken to Birdsong**  
Out in the country, yet within minutes of town makes this maintenance free 3 bedroom, 1 1/2 bath ranch ideal. Large family room with full wall fireplace, and a fully finished basement, beautifully appointed throughout, with a 24" wood deck, attached 2 car garage, 2 stall barn, all on 2 spacious acres of property. Quick occupancy and our home warranty. Asking \$114,500. Call 453-7600

**Unbeatable Bargain**  
Better hurry on this quality built and well maintained 3 bedroom all brick ranch in Livonia. Beautifully finished basement with an extra bedroom and an abundance of storage area. Natural hardwood floors throughout, a spacious 24' country kitchen, extra blown in insulation, wood windows, fenced-in yard, 13 month home warranty protection, and just \$49,900. Call 453-7600

**7 1/2% Simple Assumption**  
Extraordinarily impeccable 2000 sq. ft., 4 bedroom, 2 1/2 bath brick colonial. Natural fireplace and wood planking in the family room, formal dining room, full basement and a large country kitchen. The rear yard has a 40x20 ft. heated inground pool with cabana, and backs to a wooded area. Large patio with double gas barbecue. Asking \$86,900. Call 453-7600

**Immediate Occupancy**  
Move right into this brand new and economically insulated 3 bedroom brick ranch. Very cozy family room with free

**Century 21**  
HARTFORD WEST  
Each office is independently owned and operated.

915 S. MAIN ST.  
PLYMOUTH  
**453-7600**

**BUILDER'S CLOSEOUT**  
**Sudbury Woods**  
DESIRABLE FARMINGTON HILLS

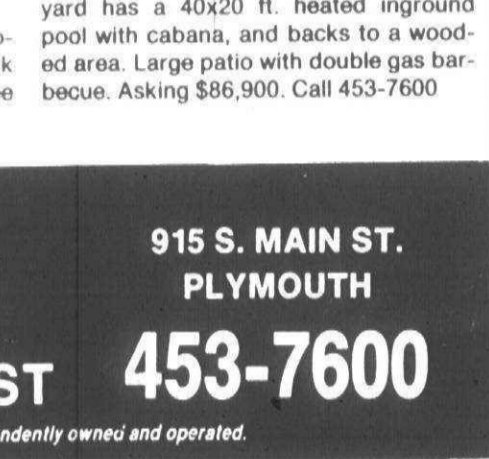

OPEN SAT & SUN 1-6 PM  
or call for appointment

Directions - S. of 14 Mile Rd., W. of Drake. S. of 14 Mile on Berryhill, turn right on Forestville, proceed west to Sudbury Dr.

Price Range \$137,900 to \$158,900

- 3 Elegantly Classic Colonials ready for immediate occupancy.
- Distinctive Colonials, Ranches, & Quads can be built to your satisfaction.
- Numerous sites to choose from, some overlooking treed valley.
- "HOW" 10 year Home Warranty
- Custom Crafted by Derin Construction Co.
- Brokers Welcome

For More Information Call BOB MASSARON  
851-4100

VINCENT N LEE  
Executive Transfer Sales  
7499 Middlebelt Road  
West Bloomfield, Michigan 48033

**WOLFE**  
COMPANY 474-5700  
33235 Seven Mile

**WOLFE**  
COMPANY 474-5700  
33235 Seven Mile

**WOLFE**  
COMPANY 421-5660  
32398 Five Mile

**WOLFE**  
COMPANY 421-5660  
32398 Five Mile

**WOLFE**  
COMPANY 421-5660  
32398 Five Mile

**WOLFE**  
COMPANY 421-5660  
32398 Five Mile

**WOLFE**  
COMPANY 421-5660  
32398 Five Mile

**WOLFE**  
COMPANY 421-5660  
32398 Five Mile

**WOLFE**  
COMPANY 421-5660  
32398 Five Mile

**BUILDER'S CLOSEOUT**  
**Sudbury Woods**  
DESIRABLE FARMINGTON HILLS

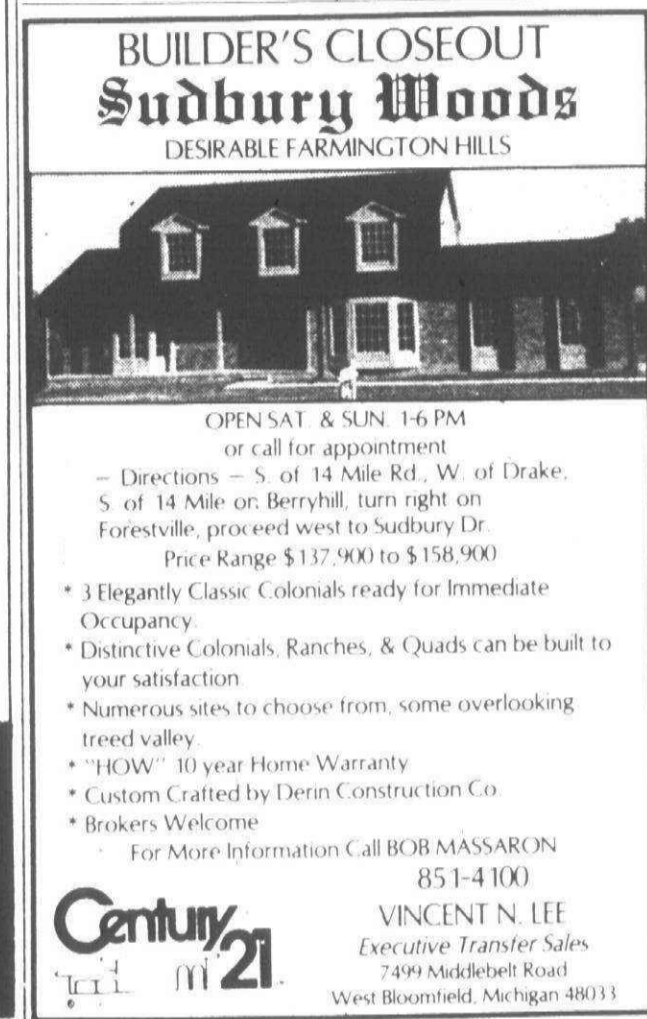

OPEN SAT & SUN 1-6 PM  
or call for appointment

Directions - S. of 14 Mile Rd., W. of Drake. S. of 14 Mile on Berryhill, turn right on Forestville, proceed west to Sudbury Dr.

Price Range \$137,900 to \$158,900

- 3 Elegantly Classic Colonials ready for immediate occupancy.
- Distinctive Colonials, Ranches, & Quads can be built to your satisfaction.
- Numerous sites to choose from, some overlooking treed valley.
- "HOW" 10 year Home Warranty
- Custom Crafted by Derin Construction Co.
- Brokers Welcome

For More Information Call BOB MASSARON  
851-4100

VINCENT N LEE  
Executive Transfer Sales  
7499 Middlebelt Road  
West Bloomfield, Michigan 48033

**WOLFE**  
COMPANY 421-5660  
32398 Five Mile

**WOLFE**  
COMPANY 421-5660  
32398 Five Mile

**Century 21**  
VINCENT N LEE  
EXECUTIVE TRANSFER SALES  
851-4100

**313 Dearborn**  
**Dearborn Heights**

LARGE LOT  
Provides lovely setting for this 2 bedroom home with family room, fireplace, 1 1/2 baths, central air and 2 car garage. \$57,900.

Executive Realtors  
476-5990

QUAD LEVEL, custom built 1977, 4 bedrooms, 2 1/2 baths, air, large master bedroom w/dressing deck, immaculate. Reduced to \$106,500. 563-5460

(67-AM) WE FEEL we've got something very special - a lovely 3 bedroom brick ranch that shows like a model home. New Soltarian kitchen floor, central air, plush new carpeting throughout, rec. room, private backyard with double gas barbecue, garage. \$59,900.

**Century 21**  
VINCENT N LEE  
EXECUTIVE TRANSFER SALES  
851-4100

**314 Plymouth-Canton**

**Beautiful Homes Offered by ...**

**Century 21**  
Gold House Realtors  
OPEN SUN 1-4  
JULY 20, 1-4 PM.

PLYMOUTH TWP.

8810 ELMHURST - Ranch, N. of Jop. E. of Sheldon \$55,900.  
41217 MARLIN - Ranch, S. of Ann Arbor Rd. W. of Haggerty \$75,900.  
6498 BAYVIEW - Ranch, S. of Ann Arbor Rd. W. of Sheldon \$86,500.  
45134 TURTLEHEAD - Ranch, N. of Ann Arbor Rd. E. of Canton Center \$122,500.

CANTON  
39738 EDMONTON - Quad, S. of Jop. E. of 275 \$85,900.  
417 MERIMAC - Colonial, S. of Cherry Hill. E. of 275 \$69,900.  
2655 BROOKFIELD - Colonial, S. of Palmer. E. of Sheldon \$73,900.  
44425 WESTMINSTER WAY - Colonial, N. of Ford, W. of Sheldon \$75,990.  
43242 BARCHESTER - Ranch, N. of Ford, W. of Lilley \$76,900.  
7820 CLAREMONT - Quad, S. of Jop. W. of Canton Center \$95,900.

WESTLAND  
2429 TREADWELL - Ranch, S. of Palmer. E. of Newburgh \$57,800.

**Century 21**  
Gold House Realtors  
459-6000 420-2100

**Red Carpet**  
RICHTER & ASSOC. 522-3500

BY OWNER - 4 bedroom quad 3 baths, thermo windows, air, huge family room. Must Sell LC possible. Immediate Occupancy. 455-3348

BY OWNER - 3 bedroom ranch, family room with fireplace, 1 bath, tastefully decorated, Willow Creek Sub., \$62,500. Land Contract available. 455-6322

CANTON ASSUMPTION  
\$4,900  
IMMEDIATE OCCUPANCY

3 bedroom brick and aluminum colonial, family room, 2 car attached garage, 3 year old home, basement. Owner anxious to sell.

Manley, Markey, & Gayle  
535-0066

CANTON BY OWNER, Tudor, 4 bedrooms, 2 1/2 baths, custom features throughout, greenhouse window, underground sprinklers, central air, large lot, more. \$97,900. Call after 6 PM. 453-1488

CANTON TWP. ATTENTION REALTORS  
\$5,000 DOWN  
\$695 MONTH  
1 QUAD \* 1 COLONIAL  
Immediate Occupancy  
New Construction  
2 year Land Contract, 2000 sq. ft., 4 bedrooms, 2 1/2 baths, family room with fireplace, full basement, 2 car attached garage, brick four sides, completely carpeted, HOW Warranty Call 455-9080 after 1 PM or 626-1233.

DEMBS BLDG. CO.  
CANTON TWP.  
\$5,100  
Moves you in immediately into a brick Colonial or Quad Level. \$895/month. 3 year 11% Land Contract. Both homes feature 4 bedrooms, attached garage, family room with fireplace, 2 1/2 baths, carpeting. \$86,990.  
348-7410  
685-8280  
DEMBS BLDG. CO.  
CANTON, 3 bedroom ranch with family room, large lot, many extras. 9 rooms old, unbelievable assumption. 397,8641  
348-7410  
CANTON, 3 bedroom ranch, 1 1/2 baths, large family room, 2 car attached garage, \$74,000. 455-6343

**WOLFE**  
COMPANY 421-5660  
32398 Five Mile

**WOLFE**  
COMPANY 421-5660  
32398 Five Mile

**Century 21**  
VINCENT N LEE  
EXECUTIVE TRANSFER SALES  
851-4100

**314 Plymouth-Canton**

Beautiful Homes Offered by ...

**Century 21**  
Gold House Realtors  
OPEN SUN 1-4  
JULY 20, 1-4 PM.

PLYMOUTH TWP.

8810 ELMHURST - Ranch, N. of Jop. E. of Sheldon \$55,900.  
41217 MARLIN - Ranch, S. of Ann Arbor Rd. W. of Haggerty \$75,900.  
6498 BAYVIEW - Ranch, S. of Ann Arbor Rd. W. of Sheldon \$86,500.  
45134 TURTLEHEAD - Ranch, N. of Ann Arbor Rd. E. of Canton Center \$122,500.

CANTON  
39738 EDMONTON - Quad, S. of Jop. E. of 275 \$85,900.  
417 MERIMAC - Colonial, S. of Cherry Hill. E. of 275 \$69,900.  
2655 BROOKFIELD - Colonial, S. of Palmer. E. of Sheldon \$73,900.  
44425 WESTMINSTER WAY - Colonial, N. of Ford, W. of Sheldon \$75,990.  
43242 BARCHESTER - Ranch, N. of Ford, W. of Lilley \$76,900.  
7820 CLAREMONT - Quad, S. of Jop. W. of Canton Center \$95,900.

WESTLAND  
2429 TREADWELL - Ranch, S. of Palmer. E. of Newburgh \$57,800.

**Century 21**  
Gold House Realtors  
459-6000 420-2100

**Red Carpet**  
RICHTER & ASSOC. 522-3500

BY OWNER - 4 bedroom quad 3 baths, thermo windows, air, huge family room. Must Sell LC possible. Immediate Occupancy. 455-3348

BY OWNER - 3 bedroom ranch, family room with fireplace, 1 bath, tastefully decorated, Willow Creek Sub., \$62,500. Land Contract available. 455-6322

CANTON ASSUMPTION  
\$4,900  
IMMEDIATE OCCUPANCY

3 bedroom brick and aluminum colonial, family room, 2 car attached garage, 3 year old home, basement. Owner anxious to sell.

Manley, Markey, & Gayle  
535-0066

CANTON BY OWNER, Tudor, 4 bedrooms, 2 1/2 baths, custom features throughout, greenhouse window, underground sprinklers, central air, large lot, more. \$97,900. Call after 6 PM. 453-1488

CANTON TWP. ATTENTION REALTORS  
\$5,000 DOWN  
\$695 MONTH  
1 QUAD \* 1 COLONIAL  
Immediate Occupancy  
New Construction  
2 year Land Contract, 2000 sq. ft., 4 bedrooms, 2 1/2 baths, family room with fireplace, full basement, 2 car attached garage, brick four sides, completely carpeted, HOW Warranty Call 455-9080 after 1 PM or 626-1233.

DEMBS BLDG. CO.  
CANTON TWP.  
\$5,100  
Moves you in immediately into a brick Colonial or Quad Level. \$895/month. 3 year 11% Land Contract. Both homes feature 4 bedrooms, attached garage, family room with fireplace, 2 1/2 baths, carpeting. \$86,990.  
348-7410  
685-8280  
DEMBS BLDG. CO.  
CANTON, 3 bedroom ranch with family room, large lot, many extras. 9 rooms old, unbelievable assumption. 397,8641  
348-7410  
CANTON, 3 bedroom ranch, 1 1/2 baths, large family room, 2 car attached garage, \$74,000. 455-6343

**SHENANDOAH CLUSTER HOME**

**BUILDER'S CLOSEOUT!**

**2 BEDROOM - 1 1/2 BATH**

**\$52,900**

**20% DOWN**

**10 1/2% INTEREST**

**30 YEAR MORTGAGE**

Four bedrooms, two full and one half baths, air conditioning, library plus family room, wood railings, professionally decorated, including plush carpeting, quartz tile foyer and powder room and many other custom features. Professionally landscaped.

Priced at \$168,500

Model Hours: 1-6 Daily and Sunday (Closed Thursday). Models located on Claymore, South of 14 Mile Road and East of Drake Road.

Model 661-1400 Office 855-2646

IRVINE-WOLOK BUILDERS

**BUILDERS' MODEL**

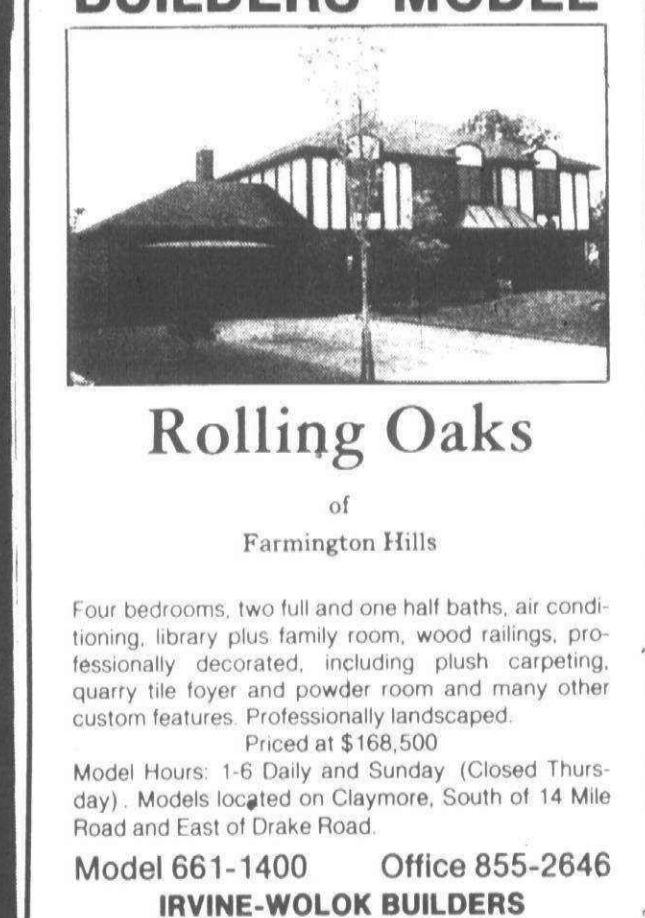

**Rolling Grapes**

of Farmington Hills

Four bedrooms, two full and one half baths, air conditioning, library plus family room, wood railings, professionally decorated, including plush carpeting, quartz tile foyer and powder room and many other custom features. Professionally landscaped.

Priced at \$168,500

Model Hours: 1-6 Daily and Sunday (Closed Thursday). Models located on Claymore, South of 14 Mile Road and East of Drake Road.

Model 661-1400 Office 855-2646

IRVINE-WOLOK BUILDERS

**OLD real estate FISCHER**

1108 S. Main St., Plymouth 455-5100

SHARP STARTER HOME! In City of Plymouth, 2 bedrooms, full basement and new furnace and roof. \$43,000.

CITY OF PLYMOUTH - 2 bedrooms with a third possible upstairs. Full basement and 2 car garage. \$51,000.

TOWNSHIP OF PLYMOUTH - Brick ranch on 1/2 acre 3 bedrooms, family room, den and 2 car garage. Asking \$87,000.

**OPEN SATURDAY & SUNDAY 1:00 to 5:00**

**CAMBRIDGE REALTY**

7500 Newburgh Rd  
Phon... Model - 453-0230

Westland, Michigan  
Office - 455-3460

Each Office is Independently Owned  
670 S. MAIN STREET • PLYMOUTH • 455-8400

ALMOST FIVE ACRES OF COUNTRY LIVING and a home of superior quality, spotless three bedroom brick ranch offers walkout recreation room, 2 1/2 baths, 2 fireplaces, situated off a winding country road with stream in rear of property. \$149,900.

LOVELY LIVONIA. Three bedroom brick ranch with covered patio, pool for summer fun, sharp finished recreation room with bar, carpeted tastefully through the home and many more distinctive features. Call today for details!

INTEREST RATE REMAINS 9% on low assumption, quick occupancy is offered on this three bedroom 1 1/2 bath colonial with 2 car attached garage, super price. \$67,500

NICE 8 3/4% ASSUMPTION available on this four bedroom quad-level, 2 1/2 baths, formal dining room, nice patio, hardwood floors, located on corner lot in desirable sub with pool, clubhouse and tennis court. Excellent opportunity for the smart buyer. \$96,400

PRICE ADJUSTED to reflect sellers' needs, beautiful four bedroom quad-level, with 2 1/2 baths, first floor laundry, in-ground sprinkler system, immediate occupancy and much more. An excellent investment at \$83,900.

FANTASTIC VALUE - three bedroom brick colonial on court location, formal dining and living room, plush carpeting and full basement. All this plus large kayak pool! Simple assumption at 9% land contract terms with less than \$25,000 down at 11% available. \$73,900.

SPARKLING CLEAN three bedroom brick ranch in desirable Plymouth Township. Don't miss the fantastic sun porch and finished recreation room. \$65,800.

OPEN SUNDAY, July 20, 2-5 P.M.  
11367 Brownell, E. of Haggerty,  
S. of Ann Arbor Trail

314 Plymouth-Canton

CANTON - By Owner Assumable 10% VA mortgage 1 year old, 3 bedroom, 2 1/2 bath Colonial family room with fireplace, dining room, kitchen with nook, 1st floor laundry. \$84,900. Call 453-8075

CANTON

Four (4) bedroom Colonial. Super Sharp! Elegant entrance with large foyer and open stairway. Also featuring formal dining room, family room with natural fireplace, 2 1/2 baths, beautiful finished basement with wet bar. 2 car attached garage. Simple Assumption at 8 1/2%. Asking \$77,900. Call for appointment to see & ask for

JEAN PROCH CHAMBERLAIN 721-8400

BRIGHTON YOUR FUTURE with this beautifully decorated 3 bedroom, 1 1/2 bath brick colonial featuring family room with fireplace, finished basement, attached 2 car garage and more for \$64,900. A terms considered

CENTURY 21 CORNERSTONE 478-4660

BUY FROM owner & earn the full commission. Priced \$5,000 below appraised value. Assumable mortgage. 3 year old quad with unique floor plan. Family room with natural fireplace, large patio backs up to woods. Excellent neighbor hood. \$75,900. 981-1743

BY OWNER in one of Canton's most sought after sub-division beautiful center pillared colonial with winding staircase on large corner lot. Features 4 bedrooms, 2 1/2 baths, formal dining room, family room with natural fireplace, built in bookcases, wet bar, 1st floor laundry. Also featuring central air. Two many extras to mention. Must see to appreciate. Asking \$89,900. Call 453-8336 or if no answer on weekends 453-8437

CITY OF PLYMOUTH CONVENIENCE

Take an easy walk to town from this well decorated 3 bedroom brick ranch. This ready to move into home includes central air dishwasher, wash tank, computer and much more. WONT LAST AT \$54,900

A PAMPERED BEAUTY with a large not personality in this impeccable 3 bedroom colonial. Fully decorated and maintained. This home offers you family room, large kitchen, full basement, 2 car garage. CENTRAL AIR and much more. A MUST SEE AT \$69,900

THIS LOVELY 4 BEDROOM COLONIAL is well priced for the area. Many custom features include fully carpeted formal dining room, family room, large kitchen, fenced yard, central air purifier, patio and professionally landscaped lot. AN EXCEPTIONAL BUY. \$83,900

EARL KEIM Realty South, Inc. CALL 453-0012

COUNTRY LIVING on this 100x216 lot, 3 bedroom aluminum sided home with beautiful family room with natural fireplace, attached 2 car garage, much more and just \$69,900. Land Contract terms

GARLING Realty 453-4800

Drastically Reduced New England style colonial features 4 bedrooms, 1st floor utility, formal dining room, natural fireplace in family room, nicely decorated throughout, 2 1/2 baths, 30 ft deck and gas grill, attached 2 1/2 car garage, immediate occupancy. Simple assumption available. Also call about mortgage available below current interest rate. Priced at \$79,900. CENTURY 21 Gold House Realtors 420-2100

Just Listed

A nice brick ranch offering 3 bedrooms, family room with natural fireplace, Summer privacy with the wood deck and wood fence. Owner transferred. Bring offers. Priced to sell at \$61,900.

CENTURY 21 Gold House Realtors 420-2100

Century 21 Gold House Realtors 459-6000

Boardwalk div. 459-3600

CENTURY 21 Boardwalk div. 459-3600

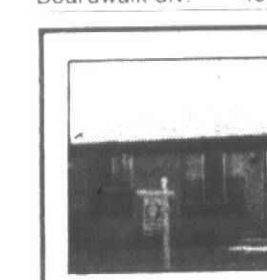

LAND CONTRACT TERMS with less than \$20,000 down makes this home a value not to be overlooked! Three bedrooms with an extra room in the basement, large 2 1/2 car garage, large kitchen, family room with fireplace, covered patio and much more. Call Mary Jo today for an appointment. \$61,900. 397-3023

REALTY WORLD Wm. Decker, Inc. 455-8400

Open Sunday 2-5 P.M. 42033 Old Bridge



McKAY REAL ESTATE REALTOR AND CONSTRUCTION CO., INC. MULTI-LIST SERVICE

Looking for privacy??? Brand New 3 Bedroom home with unique floor plan on 2 1/4 Acres. Combined family/dining room makes a great place for the family to "gather" round the fireplace. \$78,500. RR736

Now Accepting Offers to Purchase. If you're looking for 10 acres, rolling, some with woods, southern exposure, earth home sites, hurry...13 parcels won't last at these prices

Enjoy Retirement living at its best!! Co-op Apartment located on Lake Angela in South Lyon Township. Enjoy a spectacular view from your patio window. All lake privileges. The landscaping of the manicured lawns is excellent. Only \$29,900. RR735

Executive Horse Ranch!! A square 10 acres of gently rolling land, 2 barns brick and cedar. Ranch home features large country kitchen, 2 fireplaces, walkouts, 2 1/2 baths, land contract with \$17,000 down. Only \$89,900. RR652

BRIGHTON from Detroit 477-8621 HOWELL from Detroit 476-2284

314 Plymouth-Canton

FIRST OFFERING Immaculate 3 bedroom brick colonial in Plymouth's Mayflower Sub. 2 1/2 baths, dining room, beamed ceiling in family room with fireplace, 2 car attached garage, large patio. Beautifully decorated with custom drapes. Approximately 1900 sq. ft. \$87,500

Rizzo Realty, Inc. GALLERY OF HOMES 349-1515

Gold House Offers PLYMOUTH TWP. Children wanted! Offering - 4 bedrooms, family room, 40 ft. patio, fenced yard and central air. \$62,900

IMMACULATE Are you a perfectionist. Preview this 4 bedroom colonial with sunken living room, raised dining area, main floor laundry, private coat and secluded treed backyard, lovely deck, garage door opener, and central air. 9 1/2% assumption \$98,900 Open Sun. 1-4 P.M. S. of Sheldon.

2 KITCHENS ??? What an investment! 3 bedroom ranch, featuring family room, main floor laundry, 2 fireplaces, central air and 3 additional bedrooms, living room and kitchen on lower level. \$74,900

Century 21 Gold House Realtors 459-6000

HOLIDAY PARK QUAD OPEN SUN. 2 to 3 bedrooms 1 1/2 baths, natural fireplace, finished basement, 2 car garage, corner lot, sunken pool, 6 ft. privacy fence, large yard, \$72,900. 7812 Holly dr. corner Koppernick. Days, \$62,1010 eves. 453-2187

IMMEDIATE OCCUPANCY - OTHERS AVAILABLE. FROM \$129,500 - SHOWN BY APPOINTMENT. 348-7410 685-8280 DEMBS BLDG. CO.

\$22,000 ASSUMES 3 bedroom ranch with huge basement attached garage, cathedral ceiling, natural fireplace, panelled family room, beautiful wood cabinets, large kitchen, separate dining area and more. Only \$62,900. Call 459-3700

Century 21 Boardwalk div. 459-3600

NOTTINGHAM FOREST 4 bedroom 2 1/2 bath Colonial, 1st floor laundry, beamed family room with wet bar, private wooded lot, 9 1/2% Simple Assumption. Asking \$89,900. 453-2214

OOPS! You missed me - I am across from Holiday Park Nature Center in lovely country setting. 3 bedrooms all remodeled with new carpeting throughout, family room and garage. Hurry! Only \$44,900.

Century 21 Gold House Realtors 459-6000

OPEN HOUSE SUN. July 20, 2-7 pm 4 bedroom colonial 2 1/2 bath, den, fireplace, 1 1/2 baths, fully carpeted, landscaped family room with wet bar, private flower Sub. Canton \$93,900. 459-9885

OPEN SAT. 1-4 PM Simple Assumption! On this almost new 3 bedroom Colonial in Mayfair Village. Gracious open floor plan with bay window in living room, formal dining room, generous family rooms with fireplace, light neutral colors throughout, large 1st floor laundry, full basement, 1 1/2 baths, 2 car attached garage. Asking \$90,900

HITCHCOCK GALLERY OF HOMES 453-2210

OPEN SUN. 2-5

42762 SALT RD (S. of Ford, W. of Liljeholm) Spacious 4 bedroom brick & aluminum Colonial, 2 1/2 baths, family room, natural fireplace, formal dining room, many desirable luxury features. Owners anxious, TRANSFERRED. MUST SELL! BRING ALL OFFERS.

Real Estate NETWORK John Cole Realty 455-8430 255-5330

VA TERMS City of Plymouth - 3 bedroom brick ranch on larger lot, 13 month warranty available - good starter home. Oversize garage, partially finished basement. Only \$56,900.

Century 21 Gold House Realtors 459-6000

Boardwalk div. 459-3600

314 Plymouth-Canton

Open Sun. 2-5 7319 Admiralty In Canton, North of Warren, West of Canton Center Rd. Canton's finest sub offering a simple assumption on this 4 bedroom, 2 1/2 bath brick colonial with family room, fireplace, 2 car attached garage, central air, & dark room in basement. Good Crest Warranty. View this home Sunday. Call today. \$91,900.

Century 21 Boardwalk div. 459-3600

PLYMOUTH TWP. Attention Transferes Attention Renters \$10,000 DOWN \$975 per month

2 year land contract on these 2,900 sq ft. Colonials including 4 bedrooms, 2 1/2 baths, den, 1st floor laundry, 2 car attached garage, paneled family room with fireplace & wet bar, wallpaper, all built-in kitchen appliances, no wax floor, wood windows, custom trim. What are you waiting for? You will never be able to buy your new home again with these terms! To see call 453-9080 after 1 PM or 626-1223

DEMBS BLDG. CO.

PLYMOUTH TWP. Sharp new Quad-Level with basement on large lot! Beautiful family room with wet bar, 4 bedrooms, 2 1/2 baths, master bedroom has bay window, carpeted, 2 car garage.

IMMEDIATE OCCUPANCY - OTHERS AVAILABLE. FROM \$129,500 - SHOWN BY APPOINTMENT. 348-7410 685-8280 DEMBS BLDG. CO.

\$22,000 ASSUMES 3 bedroom ranch with huge basement attached garage, cathedral ceiling, natural fireplace, panelled family room, beautiful wood cabinets, large kitchen, separate dining area and more. Only \$62,900. Call 459-3700

Realty World CHAPMAN WEST \$44,900!

BRICK HOME with full basement, garage, carpeting, built in oven and range, gas heat, well landscaped. Immediate occupancy. \$44,900.

TEPEE 28200 7 Mile 533-7272

2 ACRES-Ply. Twp. Situated on one of the highest areas in Wayne County affords you a breathtaking view of the sunset. This impeccable home offers 4 bedrooms, walk in closet and bath off master bedroom, dining area, family room, natural fireplace, planning deck and built-in appliances in kitchen, utility room with storage, 2 car garage, shed, nicely maintained grounds and 13 month Warranty \$122,900 Call.

SCOTTI FLORA CENTURY 21 Gold House Realtors 420-2100

4 ACRES - NEEDS WORK \$49,900 for roomy 1 story home with large unfinished room that can be family room or additional bedroom, near Haggerty and Michigan Ave. Land contract plus other terms. Century 21, A/R. 425-3250

7 1/2% SIMPLE ASSUMPTION Compare the price, condition and terms of this 3 bedroom split level with living room, living room, huge family room with full wall fireplace, patio, 2 1/2 garage and oversized landscaped lot. Reduced to \$55,900. Call 459-3700 now it won't last.

Realty World CHAPMAN WEST

FIRST OFFERING. Exceptionally well decorated and maintained colonial on a secluded court setting in prestigious COLONY FARMS. An impressive foyer and open stairway add to the appeal. Four spacious bedrooms, 2 1/2 baths, den and first floor laundry. The family room overlooks a large wood deck shaded by mature maple trees. \$155,000. 453-6800

FARMINGTON Tender loving care is the word on this 4 bedroom colonial. Central air, attractively decorated recreation room, 2 car attached garage. Located in Farmington's finest neighborhood communities. A-152 \$84,900. 477-6300

GARDEN CITY Bright and cheerful is this beautiful 3 bedroom brick ranch. Large country kitchen, full basement, nice fenced yard, maintenance free exterior, convenient location. F.H.A. or V.A. terms. A-143 \$46,900. 477-6300

LIVONIA GRANDON WOODS A mature treed location surrounds this exceptional brick ranch offering three bedrooms, FORMAL DINING ROOM, living room with NATURAL FIREPLACE, full basement and garage. Many custom features \$57,900. 453-6800

QUAD LEVEL in excellent Canton Township location offers four spacious bedrooms, huge family room with natural fireplace, large kitchen and dining area. Real living room overlooks inground pool. Two car attached garage \$72,900. 453-6800

QUANTITY AND QUALITY - Exceptional in every detail is this spacious four bedroom colonial which features a huge family room with energy efficient wood burning fireplace plus the convenience of a den. Fantastic kitchen, formal dining room, first floor laundry, two car attached garage. A home you'll find much to admire and be enthused about. \$95,900. 457-16 Bartlett - South of Joy and West of Canton Center. 453-6800.

LOOK NO FURTHER This three bedroom brick ranch in Westland has everything. Large kitchen, family room with natural fireplace, full basement and two car garage. Excellent location. \$55,900. 453-6800

QUAD LEVEL in excellent Canton Township location offers four spacious bedrooms, huge family room with natural fireplace, large kitchen and dining area. Real living room overlooks inground pool. Two car attached garage \$72,900. 453-6800

GUARANTEE SALES PLAN Schweitzer & Better Homes and Gardens Real Estate, Inc.

PLYMOUTH/CANTON OFFICE 218 S. Main St. - North of Ann Arbor Trail 453-6800

FARMINGTON OFFICE 21023 Farmington Road - North of Eight Mile 477-6300

314 Plymouth-Canton

PLYMOUTH - An impressive purchase opportunity in prestigious Walnut Creek. Just 2 years old, this spacious brick 2 story offers 4 large bedrooms + a main floor study, 3 1/2 baths, 2 fireplaces, huge walk-out basement (unlimited possibilities), 29 x 15 family room with fieldstone fireplace and access to elevated deck with a view of pond and green belt. Side entrance 3 car garage. CENTRAL AIR. Assumable 9 1/2% Mortgage. Excellent condition thru-out! \$188,000. 453-1020.

WESTLAND - 3 bedroom brick ranch in a most desirable neighborhood. Huge finished basement includes recreation room, full bath complete with shower, separate laundry room, furnace room and large pantry for storage. Fine home for any size family at an affordable price! 453-1020.

PLYMOUTH - Congenial atmosphere of New England Village provides 2 outstanding Colonials! Both in MOVE-IN CONDITION. Both moderately priced! They offer 4 bedrooms, 2 1/2 baths, spacious living room, formal dining room, large country kitchen with lots of cupboards and a particularly roomy dinette. Family rooms have a handsome full-wall, brick fireplace. There is a full basement and attached garage with each. Ideally located, close to schools, shopping and new X-way. In the \$80's. 453-1020.

JUST LISTED - Owner has priced this home to sell right away! At \$59,900, this clean and sharp Split-Level offers 3 bedrooms, 1 1/2 baths, extra large family room, very pleasant yard with shade trees, a deck and gas Bar-B-Q. Excellent PLYMOUTH location, walking distance to schools (and a Cloverdale Ice Cream Cone)! Won't last! 453-1020.

8498 ORHAN - This brick 2 story features 1 1/2 baths, cozy family room with fireplace, full basement & attached 2 car garage. Large 63x185 ft lot offers privacy & lots of room. Asking \$67,900

BUILDING SITES - Several in the Plymouth area to choose from. Call for details

WM. FEHLIG Realty 453-7800 944 S. Main, Plymouth

TRI-LEVEL Sharp 3 bedroom home with large country kitchen, family room with fireplace, 1 1/2 baths, carpet throughout, attached 2 1/2 car garage, many extras and asking just \$55,900.

Garling Realty 453-4800

8 1/2% Land contract terms on Builder's colonial and quad-level models located in Mayfair & Sunflower Village. Other models and specs available. Priced from \$73,600. Open Sunday 1-4 or Call Ken Koehn for information.

Century 21 Boardwalk div. 459-3600

PLYMOUTH - WALK TO DOWNTOWN from this charming 3 bedroom Cape Cod Breezeway, basement, 1 1/2 car garage, mint condition \$53,900. 626-0097

PLYMOUTH TWP. Lakepointe Sub ranch, 3 bedrooms 1 1/2 baths, family room, fieldstone fireplace, 65x120 beautifully treed lot, 12x16 patio with gas grill, \$84,900. 14881 Thornridge, near 5 Mile & Haggerty. 420-0411

Century 21 Boardwalk div. 459-3600

EXECUTIVE STYLE QUAD in Livonia - beautiful Nottingham West landscaped to perfection on large corner lot with circular drive. Tremendous family room with fireplace and wet bar. Great for entertaining. All this plus much more \$124,900. 453-6800

VALUE PLUS Beautifully customized three bedroom colonial offering solarium kitchen, oak plank floor, premium professionally landscaped lot with privacy fence. Family room with full wall raised heart fireplace overlooking patio with gas grill. Central air conditioning. \$73,900. 453-6800

LIVONIA If you are looking for that first home, this is where you should start. 2 bedroom aluminum sided ranch on beautiful 1 1/2 acre lot. Nice modern kitchen, 2 car attached garage, move in condition. A-153 \$43,900. 477-6300

NEW 3 bedroom ranch overlooks PRIVATE RAWINE LOT. Home offers formal dining room, family room with fireplace plus first floor utility room. \$79,500. 6891 Pittsford, S. of Warren - E. of Sheldon. 453-6800

QUAD LEVEL in excellent Canton Township location offers four spacious bedrooms, huge family room with natural fireplace, large kitchen and dining area. Real living room overlooks inground pool. Two car attached garage \$72,900. 453-6800

FOR SALE Schweitzer Real Estate, Inc.

Better Homes and Gardens

Better Homes and Gardens

314 Plymouth-Canton

PLYMOUTH TWP. Four bedroom colonial. Central air. Prime lot. \$69,500. 437-5045

PLYMOUTH TWP. NEW CONSTRUCTION 20%-8 1/2% 2 year land contract on this 4 bedroom, 2 1/2 bath quad featuring a 2014 master suite on it's own level with private bath, walk-in closet & large bay window. 1918 paneled family room with fireplace & custom walk in bar. 2 story foyer with bridge, custom railings banisters, formal dining room, 2 1/2 car attached garage, wood insulated with downs, custom trim & much more \$129,500. This is a must see home! Call 453-9080 after 1 PM or 626-1223

DEMB'S BLDG. CO.

REDUCED TO \$148,000 Plymouth Colony Farms 4 bedroom brick colonial, 3 1/2 baths, formal dining, family room, screened porch, beautifully finished rear room, very large lot, backs to treed park. By Owner \$55-645

SIMPLE ASSUMPTION 3 bedroom, 2 bath brick ranch. Family room with fireplace, full finished basement, garage. \$62,900

CENTURY 21 CORNERSTONE 348-6500

STARTER HOME - \$36,500 2 bedrooms, garage and large lot. (66333), 15525 Marilyn - Land Contract terms

STARTER HOME - \$48,000 (18x27) equipped for the mechanic with hook, 220 service, insulation, & water 11801 Haggerty

DRASTICALLY REDUCED TO \$61,200! This 3 bedroom brick ranch has 2 full baths, fireplace, full basement, central air and attached 2 car garage. Immediate occupancy

WOLFE COMPANY 33235 Seven Mile 474-5700

HORSE SHOE FARM Finest 27.85 acres of horse farms in the area. Cement barn with 6 stalls, feed, tack & storage rooms, electricity & water. Six (6) paddocks with six (6) 10x20 walk in shelters for horses, metal storage shed and a classic 3,000 sq. ft. Colonial with huge curved driveway \$260,000. Call 553-8700

Thompson-Brown IMMEDIATE OPPORTUNITY BUILDER'S MODEL (7 MA) One visit will spoil you for any other. See for yourself. This authentic Dutch design colonial with 4 bedrooms, 2 1/2 baths and large den for your treasured privacy. Huge family room with wood burning fireplace will be your favorite retreat. Stained woodwork, wood cabinetry, plush carpet, Italian ceramic foyer. Approximately 2600 sq. ft. \$119,900. For more information call the new home specialist.

VINCENT N. LEE EXECUTIVE TRANSFER SALES 851-4100

JUST LISTED A most unusual 2 story home in Novi's Conenara Hills Sub. 4 bedrooms, 2 1/2 baths, 1st floor utility, finished walk out lower level, fireplace, huge loft with circular staircase, 3 car insulated & paneled garage, almost 1/2 acre lot. \$109,900

Rizzo Realty, Inc. GALLERY OF HOMES 349-1515

NOVI RANCH 2 ACRES Call Jim Wilbanks Real sharp brick 3 bedroom ranch, 2 car attached garage, 2424 sq ft building, country living and 10 minutes to Northville CHALET 477-1800

315 Northville-Nowi

AN EXHILARATING SENSE of space makes for a superb floor plan in this 4 bedroom, 2 1/2 bath Colonial. Spacious den, 2 1/2 family room with fireplace, 1st floor laundry, An outstanding Value for Northville Colonials at \$135,000. Call 261-5080

Thompson-Brown BY OWNER 3 bedroom ranch, 1 1/2 baths, full basement, attached garage, family room with fireplace, patio & deck, beautifully landscaped. 349-5513

Executive Colonial in prime area is tastefully decorated & a king-size bedroom brick and aluminum home. Features - large family room with fireplace, formal dining room, 2 1/2 baths, country kitchen, large lot, patio, central air, attached 2 car garage, excellent location. \$91,500

SUPER BUY This lovely 3 spacious bedroom brick and aluminum ranch on professionally landscaped lot offers large living room, family room, step-saving kitchen, full basement, central air, attached garage. \$64,900

Swimming Pool Brick ranch offers 3 bedrooms, large living room, 1 1/2 baths, country kitchen, beautiful large lot, attached garage. \$64,900

Century 21 NADA, INC. 477-9800

EXECUTIVE TRANSFERREES Move right into this sparkling clean 4 bedroom, 2 1/2 bath brick colonial featuring formal dining room, family room and fireplace, country kitchen, first floor laundry, full basement, 2 car attached garage and more. \$104,900. HARRY S.

WOLFE COMPANY 33235 Seven Mile 474-5700

HORSE SHOE FARM Finest 27.85 acres of horse farms in the area. Cement barn with 6 stalls, feed, tack & storage rooms, electricity & water. Six (6) paddocks with six (6) 10x20 walk in shelters for horses, metal storage shed and a classic 3,000 sq. ft. Colonial with huge curved driveway \$260,000. Call 553-8700

Thompson-Brown IMMEDIATE OPPORTUNITY BUILDER'S MODEL (7 MA) One visit will spoil you for any other. See for yourself. This authentic Dutch design colonial with 4 bedrooms, 2 1/2 baths and large den for your treasured privacy. Huge family room with wood burning fireplace will be your favorite retreat. Stained woodwork, wood cabinetry, plush carpet, Italian ceramic foyer. Approximately 2600 sq. ft. \$119,900. For more information call the new home specialist.

VINCENT N. LEE EXECUTIVE TRANSFER SALES 851-4100

JUST LISTED A most unusual 2 story home in Novi's Conenara Hills Sub. 4 bedrooms, 2 1/2 baths, 1st floor utility, finished walk out lower level, fireplace, huge loft with circular staircase, 3 car insulated & paneled garage, almost 1/2 acre lot. \$109,900

Rizzo Realty, Inc. GALLERY OF HOMES 349-1515

NOVI RANCH 2 ACRES Call Jim Wilbanks Real sharp brick 3 bedroom ranch, 2 car attached garage, 2424 sq ft building, country living and 10 minutes to Northville CHALET 477-1800

315 Northville-Nowi

NOVI - By Owner Save Real Estate Commission! Attractive landscaping accents well-maintained 3 bedroom brick ranch, 2 1/2 car garage off lovely patio, fenced yard. \$59,000. SHOW BY APPOINTMENT. 533-2923, or eves, 477-0343

NOVI-Country Living (7 Acres plus! Horse welcome) OPEN SUN 2-6 49280 Nine Mile Rd. W. of Beck Rd. Brick (1977) split-level, 4 bedrooms, 2 1/2 baths, large family room with fireplace, 2 car attached garage. \$110,500. Ask for Walter Frisch. 851-6004

THE DURBIN COMPANY REALTORS Your Neighborhood Broker

NOVI DUNBARTON PINES 4 Bedroom Colonial 2,900 Sq. Ft. \$119,990 DEMBS BLDG. CO. 348-3103

NOVI This one faces a wooded park area. 3 bedrooms, 1 1/2 bath ranch with spacious country kitchen, cozy family room with fireplace, large basement, wood deck, 2 car garage, on an oversized lot. \$82,900. 478-9130

Rymal Symes LAKES OF NORTHVILLE 3,000 sq. ft. Colonial, 4 bedrooms, 3 1/2 car garage, private den on wooded lots \$139,990. DEMBS BLDG. CO. 348-7410

NORTHVILLE COMMONS OPEN SUN. 2-5 You are invited to this colonial that has a hilltop setting and a horseshoe driveway. This interior is a sight to see, many extras. Completely remodeled. 16449 Old Bedford. Call 453-4840

ERA HARDING NORTHVILLE If you are looking for a lovely Victorian home with absolutely no fix-up, many features, and a rental unit upstairs besides. Asking \$89,900. Call CAROLA

CENTURY 21 Quality Homes 349-1212 348-9365

NORTHVILLE \$59,500 Historical area, 4 bedroom aluminum colonial, basement, 3 car garage, walk to town, easy land contract terms. BRUCE ROY CO. 349-8700

NORTHVILLE NEW 3 bedroom executive colonial on large lot with wood features, and a rental unit upstairs. Must sell \$120,900. 420-0544

THREE bedroom ranch with attached 2 car garage, 1 1/2 baths, finished basement

<b>316 Westland Garden City</b> A BEAUTIFUL 4 bedroom ranch in Westland. 1 1/2 baths, full basement, carpet, large fenced yard. \$62,500. By owner. 427-6937	<b>316 Westland Garden City</b> GARDEN CITY - 2 bedroom ranch, workbench in 2 1/2 car garage, utility room, large fenced yard with garden & grape arbor. \$39,000. 525-5499	<b>316 Westland Garden City</b> BY OWNER - ASSUMPTION - L.C. Westland - 3 or 4 bedroom brick ranch. carpet thru out, finished basement, deck, garage, Livonia schools, immediate occupancy, super buy. \$47,900. 525-3600	<b>316 Westland Garden City</b> BY OWNER - 2 bedroom, Alum. side starter home. 1 1/2 garage. \$33,900. Possible Assumption. 523-5826 or 565-3470
---	--	--	---

**316 Westland Garden City**  
BY OWNER - 3 bedroom bungalow, family room, large utility room, 1 1/2 car garage. On 115 x 130 ft wooded lot. A must to see at, \$49,900. 3325 Pierce, Garden City. 453-8839

**316 Westland Garden City**  
COLONIAL, 3 bedrooms, 1 1/2 baths, 2 car attached garage with opener, central air, patio with gas grill. Close to schools & park. \$58,900. 729-3061 or 522-9232

**316 Westland Garden City**  
**BE 1ST**  
to see this steel sided ranch with natural fireplace in gorgeous living room, sharp country-size kitchen, nice work room in garage. Only \$39,900. Ask for: BRAD WERNER Century 21 Gold House Realtors 459-6000

**316 Westland Garden City**  
GARDEN CITY  
**OPEN SAT. 1-4**  
6405 HUBBARD - S. of Warren, W. of Merriman. Sharp brick ranch, features - 3 bedrooms, full basement, country lot, more. Will not lose - come see or call 474-2130  
WESTLAND - \$52,900  
**NEW LISTING**  
Sharp 4 bedroom aluminum sided home on country setting, features - 2 car garage, above ground pool, privacy backyard, more 1 showing will sell - hurry call 474-2130  
GARDEN CITY  
**Farmer's Delight**  
Sharp 3 bedroom brick ranch features country kitchen, full basement, attached 2 car garage, large lot on country setting. Call 474-2130 now.  
REAL ESTATE STATION  
GARDEN CITY  
Sharp 3 bedroom brick ranch with condition oversized garage, fantastic basement! Owner transferred. \$57,900. Bring offers.

**316 Westland Garden City**  
WESTLAND FHA & VA "D" DOWN  
With this super 3 bedroom brick tri level, large family room, carpeting, 1 1/2 baths, large covered patio. 2 1/2 car garage. \$48,900  
**CENTURY 21** STEINHAUER, INC. 326-3400  
**WESTLAND**  
Nice 3 bedroom Ranch, large country kitchen, central air, plus tiled basement and foundation and cement driveway in for a 1 1/2 car garage. A Terrific Buy at \$43,900. Call to see and ask for:  
**JEAN PROCH** CHAMBERLAIN 721-8400

## HALL & HUNTER INC.

### REALTORS

4114 West Maple, at Telegraph  
1732 West Maple, at Chesterfield



**TRADITIONAL CAPE COD**  
Unusual five bedroom residence in fashionable Beverly Hills, Royal Oak. Living room with paneled fireplace wall. Cozy den. Separate dining room. Central air. Heated inground Gunite Pool (20x40). \$94,900. 644-3500

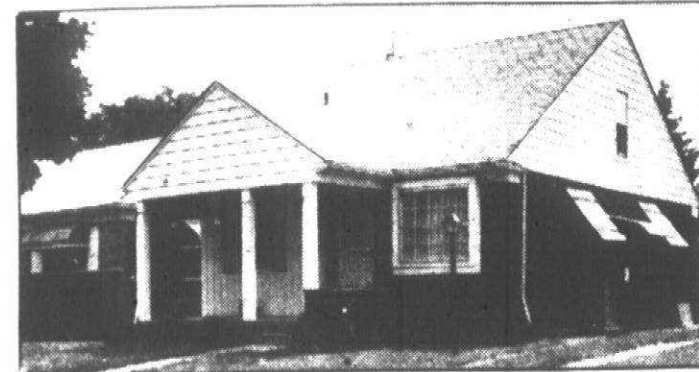

**OPEN SUN. 2-5**  
Move right into this attractive three bedroom home. Brick and aluminum trim make it MAINTENANCE-FREE. Walk to schools and transportation. 1760 Sheffield, E. off Woodward, N. of 14 Mile. \$79,000. 626-5900



**OPEN SAT. 2-5**  
Appealing 3 bedroom condominium in desirable Northfield Hills. 2 1/2 Baths. Fireplaced living room with bay window. Garage. 5790 Northfield Parkway, N. of Long Lake Rd., E. of Coolidge. \$78,900. 644-3500



**SOUTH HILLS**  
Lovely two bedroom condominium in a secluded treed area. One full bath. Powder room. Fireplaced living room. Central air. Patio with gas barbecue. Beautiful brick walled courtyard. \$80,000. 626-5900.

Two Locations - Offices Open Weekdays 8:30 a.m. to 8:00 p.m.  
Saturdays 8:30 a.m. to 5:00 p.m. - Sundays 11:00 a.m. to 4:00 p.m.

626-5900  
644-3500

## Castelli

**BEST BUY**  
In good area, 3 bedroom ranch, 2 full baths, finished basement, extra large garage, assumable \$42,900

**Red Carpet** RICTER & ASSOC. 523-3500

**Learn how you can Own your own Florida home from \$27,990.**

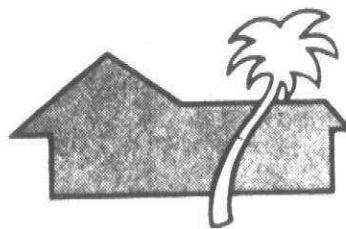

Including all furnishings and fully-landscaped lot!

You're invited to a special housing seminar to learn the interesting details about living the good life in the Sunshine State.

At this informative seminar will be discussing:

- The new 1980 model homes
- Benefits of Solar Energy
- Living costs in Florida
- Taxes
- Climate in different parts of the state
- The character of various communities
- Schools, shopping and recreation facilities

You'll also have an opportunity to see a fascinating film close-up of the carefree Florida lifestyle.

General Development - one of Florida's largest quality home builders offers new mobile homes priced as quoted above as well as affordable single-family and estate homes. We'd like to share our 24 years' experience and knowledge with you - to help you make the right decision about choosing a home in the Sunshine State. There's no obligation, of course.

July 21, 7:30 P.M.  
**HYATT REGENCY**  
Michigan Ave. at Southfield X-Way Dearborn

July 23, 7:30 P.M.  
**HOLIDAY INN**  
10 Mile & Grand River, Farmington

If you cannot attend, call or write for information.

**General Development**

28800 Southfield Road  
Lutrop Village  
Michigan 48076

552-9200

## Real Estate One, INC.

REALTORS

### HUNTINGTON WOODS

● Custom built Cape Cod on nicely treed, winding street. Large living room with French doors leading to porch. Formal dining room, updated kitchen. Den could be fourth bedroom, \$93,000. Call 548-9100. (62416)

### BRIGHTON

Spacious custom 4 bedroom ranch, central air, formal dining room, plus dining area, 2 1/2 baths, deck across back, custom draperies, Andersen windows, 2 1/2 car garage, plus finished walkout basement. Easy expressway access, 3 miles to shopping center. \$124,900. Call 227-5005.

### SOUTH LYON

Exquisite is the only way to describe the interior of this contemporary 4 bedroom (possible fifth bedroom or mother-in-law suite in den), family room, 2 fireplaces, full brick wall, first floor laundry, oversized garage, 2400 sq. ft. of living space. Rust and earth-tones decor. Private road and 1/2 acre lot. \$91,900. Call 348-6430. (64723)

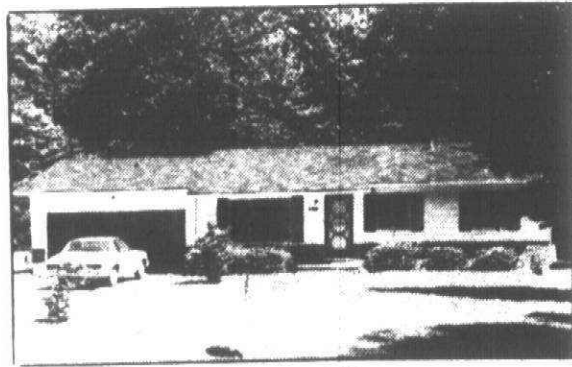

### ROMULUS

Gorgeous custom ranch on 88x140' country lot. Family room, country kitchen, oversized attached garage. All rooms are extra large. Sharp as a pin. Show to fustiest buyers. \$60,000. Call 326-2000. (64747)

### LIVONIA

● Beautiful home situated on a premium Commons lot. 4 bedrooms, 3 full baths, formal dining room, family room with wet bar, finished basement. Enclosed Florida room. \$128,300. Call 525-0990. (63729)

### TROY

The ultimate in convenience. You can move right into this sharply decorated 2 bedroom townhouse Condo. Gracious step down living room with handsome fireplace opens to private patio. Basement offers extra storage. Located near wooded area for peaceful enjoyment. \$68,500. Call 644-4700.

### SOUTHFIELD

● Maintenance free 4 bedroom colonial in northern Southfield location. Below market interest rate available. This won't last. \$71,900. Call 559-2300. (65155)

● Large 3 bedroom Tri-level with possible fourth bedroom. 2 car attached garage with door opener. Immediate occupancy. \$82,900. Call 559-2300.

### GARDEN CITY

Enjoy the best. 3 bedroom brick ranch. Recreation room with wet bar and half bath, 2 car garage. \$48,900. Call 326-2000.

### WESTLAND

● Newly carpeted family room with charming Franklin fireplace comes with this 3 bedroom ranch. Terrific storage and counter space in country kitchen. Central air, basement, dishwasher. Livonia schools. \$49,900. Call 525-0990. (61621)

Immediate occupancy on this spotless Condo facing lovely Commons area. 2 1/2 car attached and insulated garage. All kitchen appliances and draperies included. Pool and Clubhouse. \$63,900. Call 455-7000. (65119)

### CLAWSON

● Cozy brick ranch on street of attractive well-kept homes. Walk to elementary school. Fourth bedroom in basement, with closet. \$49,900. Call 528-1300.

### ROYAL OAK

● Imagine - Here is a chance to do it your way. This cozy 3 bedroom home is ready for your imagination. All it needs now is you. If there's a better opportunity at this price in this desirable neighborhood - buy it. Room for growth, plenty of storage, a garage designed for a mechanic or handyman. \$37,500. Call 528-1300. (63455)

### FARMINGTON HILLS

● An executive ranch, approximately 2500 sq. ft., in Green Hill Woods, central air, 3 bedrooms, Den (could be fourth bedroom), formal dining room, family room with French doors leading out to deck in wooded backyard. Home has energy package (\$5,000), upgraded carpeting, ceramic tile in large foyer, circular drive. Many extras. \$154,900. Call 261-0700.

Charming 2 year old 3 bedroom early American colonial. Large park-like fenced yard. Extra features to please you and your pocketbook. \$76,900. Call 477-1111.

Spacious 4 bedroom, den, family room. Well decorated with natural tones throughout. Attractive redwood deck nestled in lovely treed lot. Beautiful area of prestigious homes with parks and ponds in neighborhood. \$118,500. Call 477-1111.

● Executive living at its finest. This 5 year old colonial located in Independence Commons is a former model. It is professionally decorated and immaculately kept. Raised hearth fireplace in family room, no-wax floors in kitchen and foyer are just a few of the many extras making this home one of the most desirable on the market. \$143,900. Call 477-1111. (64987)

● Immediate occupancy. Large 4 bedroom, 2 1/2 baths, 2 fireplaces, treed setting. Priced below market value. \$97,500. Call 851-1900. (65438)

● Desirable Kendallwood! Beautiful treed area. New shrubs. 2 natural fireplaces - living room and family room. Hardwood floors. All window treatments except master bedroom. Parquet floor in family room. Nicely decorated. \$85,900. Call 851-1900. (63563)

● Beautiful 3 bedroom brick ranch. Spacious rooms, 3 fireplaces, family room, 2 1/2 baths. On almost 2 acres. In gorgeous area. Inground heated pool. \$144,900. Call 525-0990. (64248)

Lovely 2 bedroom. Closed in terrace home on a treed lot. Excellent condition, carpeted, draped, oven/range and refrigerator. Perfect for retired couple or newly wed. Move in at closing. Close to everything. \$59,500. Call 644-4700

### REDFORD

ENJOY YOURSELF in lovely knotty pine recreation room with built-in stereo speakers. Newer roof and gutters, range and dishwasher included. 1 1/2 baths plus low taxes and super area. \$56,900. Call 525-0990. (64511)

### NOVI

● Fantastic 4 bedroom ranch, huge living room with sunken fireplace cove. Formal dining area. Great for entertaining! Barbecue on the large patio or take a swim in the subdivision pool. Immediate occupancy. \$87,500. Call 348-6430. (62203)

2 bedroom Condo, full basement, central air, automatic garage opener with remote control. End unit. Immediate occupancy. \$59,500. Call 261-0700. (65101)

### BIRMINGHAM

● Cheerful brick ranch in excellent location. This well maintained 3 bedroom, fireplaced living room, dining room ranch offers an eat-in-kitchen, plus much more. \$76,900. Call 648-1600.

● Beautiful in town Birmingham colonial. Large dining room. Attached garage. Close to excellent schools, Eton Park and commuter train. Early possession! \$77,500. Call 851-1900. (64076)

● Beautifully maintained custom Quad on a parklike setting in sleepy village of Franklin. Huge oak trees, backs to picturesque stream. \$644-4700.

### WEST BLOOMFIELD

● 4 bedroom colonial on beautiful lot with lots of privacy. Family room paneled with built-in bookcases, parquet floor. Area of very nice homes. \$128,900. Call 851-1900. (65387)

### CANTON

● Lovely large King Richard Model. 4 bedrooms, 2 1/2 baths, family room, fireplace, covered patio. Assumption, requalify. Beautifully landscaped. \$91,900. Call 348-6430

● Beautiful Williamsburg colonial that features 4 bedrooms, 2 1/2 baths, formal dining room, first floor laundry, family room with natural fireplace, central air and so much more. \$84,900. Call 455-7000.

● Beautiful Tri-level with central air, plush carpeting throughout and full wall fireplace in family room. 3 bedrooms, 1 1/2 baths, electric garage door opener and professionally landscaped. \$59,900. Call 455-7000. (64785)

### BLOOMFIELD HILLS

CHARMING HOME, GRACIOUS LIFESTYLE for the young family in this friendly neighborhood. Walk to local swim club or public tennis courts. 3 bedrooms, family room with fireplace plus recreation room. \$105,900. Call 646-1600. (63677)

### LIVONIA

● Fantastic brick ranch. 3 bedrooms, 2 baths, formal dining room, family room, finished basement. Near schools and shopping. Immediate occupancy. \$58,900. Call 261-0700.

● Kingsbury Heights. Executive colonial offers 4 bedrooms, 2 1/2 baths, formal dining room, fireplace 1/2 family room and central air, are just a few of the fine features to be found in this properly priced spacious home. Attractively landscaped in a location offering convenient access to schools, shopping and expressways. \$92,000. Call 261-0700.

Extraordinary 3 bedroom ranch, central air, roll automatic window treatment on all windows, including Florida room, 2 car garage with door opener, recreation room with wet bar and stereo. \$59,500. Call 261-2600. (64439)

Sharp 3 bedroom ranch in a nice area. Near Livonia Shopping Mall. \$49,900. Call 261-2600. (64982)

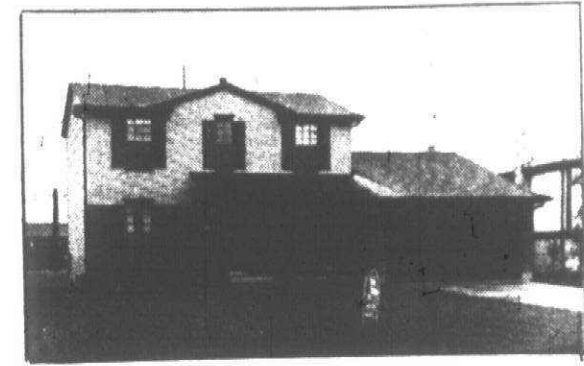

### CANTON

Lots of extras in this spacious colonial. Beautiful pegged hardwood floors in living room and formal dining room. Huge country kitchen, family room with natural fireplace. \$74,500. Call 455-7000. (65214)

### ROCHESTER

Former model. New large colonial featuring beautiful wood staircase, crown moldings, stone fireplace and wet bar in beamed family room. Fully decorated. Large tree in landscaped front yard. \$116,900. Call 652-6500. (64323)

RELO WORLD LEADER IN RELOCATION REALTORS





## Helping you cope with inflation...

With inflation plaguing the United States, the economic picture is gloomy. Not only are food and energy costs increasing, but prices on consumer goods are also soaring.

Your need for savings now is as great as ever. Take advantage of all that the market offers by reading the Classified ads. If you shop the ads for value, you'll find you can cut back on spending. Use Classified advertising as your inflationary savings strategy!

Observer & Eccentric  
**classified**

Dial Classified Direct: LIVONIA - 591-0900 BIRMINGHAM - 644-1070 ROCHESTER/AVON TWP. - 852-3222

316 Westland Garden City OWNER TRANSFERRED 31760 Marquette 3 large bedrooms 19 ft. family room, huge brand new country kitchen, 2 1/2 car garage. Excellent assumption available. Asking \$53,900. GARLING INC. 582-4144 274-3500

CENTURY 21 TODAY 525-7700 Livonia Schools Beautiful brick style ranch in an excellent area of Westland, featuring - 3 spacious bedrooms, nicely finished basement with extra bed room and 1/2 bath, kitchen appliances, dining area off living room and immediate occupancy. Priced at \$49,900. Call: ROB FUNK CENTURY 21 Gold House Realtors 420-2100

318 Redford FIRST OFFERING on this super 3 bedroom, 1 1/2 story bungalow. Large remodel kitchen, full bath, full living area off to elegant 14 x 14 wood deck, partial finished basement, 2 1/2 car garage, plus nice treed lot. Asking \$42,900. For more information call MIKE WICKHAM CENTURY 21 CORNERSTONE 478-4660

EARL KEIM 538-8300 REDFORD INC. HANDYMAN SPECIAL! This Lakeland 2 story home has 6 bedrooms, full basement, dining room, huge lot. Land contract terms. Bring all offers. Make money at \$39,900. SUPER STARTER! Clean, comfortable as just a few words to describe this 2 bedroom bungalow. Separate dining room and enclosed front porch. Just remodeled beautiful spacious yard. Hurry, this home will not last. Only \$29,900. TEPEE 28200 7 Mile 533-7272

REDFORD Completely customized home in S. Redford 5 zone HWBIB. Attached 2 1/2 car heated garage, all finished, large room with full bath, 2 fireplaces with 1 in a large family room are just a few of the many things that make this home a home. Please call for more information. Only \$73,500. Veterans welcome. Rymal Symes 538-7740

REDFORD McArthur - 5 Mile Area California owner Bargain time \$49,900. Attached garage, face brick, 1 1/2 baths, 2 master bedrooms, fireplace in living room, tiled basement. Call Bill Willis MAYFAIR 522-8000 REDFORD TWP. 36,900 RANCH 3 bedrooms, 1 1/2 baths, kitchen, 1 1/2 car garage. This home is a beautiful area. MAYFAIR 522-8000 "South Redford" FIRST OFFERING Sharp and spacious brick ranch featuring 3 bedrooms, modern kitchen with full bath, carpet throughout, full finished rec room and 2 car garage. Asking only \$53,900. CENTURY 21 TODAY 538-2000 SOUTH REDFORD Immediate occupancy on this sharp maintenance free 3 bedroom brick ranch. Just north of the school! Features formal dining area, 2 full baths, finished basement with full summer kitchen and play area, plus a screened in back porch, brick brick, aluminum garage with attached covered patio plus conventional. Land contract and VA terms. A terrific buy at \$59,900. Call to see and ask for JEAN PROCH CHAMBERLAIN 721-8400

STARTERS DELIGHT A 3 bedroom house with kitchen and dining room. A full basement and 2 1/2 car garage. This home is a beautiful area. HARRY S COMPANY 421-5560 SUPER SHARP 1 1/2 Story brick, 3 bedrooms, full basement, country style kitchen with brand new floor. Located in prime area of S. Redford. Priced at only \$49,900. SAYLOR REALTY 427-1700 MUST SEE 3 bedroom, possible 4th or family room, 2 full baths, first floor laundry, low taxes. Only \$42,500. CENTURY 21 TODAY 478-1040 YOU'LL CRY IF you miss this beauty 3 bedroom brick bungalow with updated kitchen built-in, snack bar, formal dining room, sun room, modern kitchen with granite countertop, full bath, 2 car garage. \$49,900. FOUR SEASONS REALTY 562-8444 \$5,000 DOWN To buy this nice 3 bedroom brick ranch, full finished basement with complete kitchen for cool cooking in summer. Garage Call for details. Dianne A. Thiede MAYFAIR 522-8000 O & E

1318 Redford WE'RE REDFORD SPECIALISTS "TELEVISION" SHOWING (save gas & time), CALL FOR AN APPOINTMENT TO VIEW OUR CURRENT LISTINGS (SCHEDULES) LET US PUT YOUR HOME ON OUR IN-OFFICE TELEVISION FOR VIEWING BY BUYERS. CALL JERRY MC KEON 261-1400 "47,900" 3 bedroom brick in prime area. Newer kitchen with dishwasher, 2 year old roof, extra insulation, finished basement, garage. SHARP! \$52,900. "ASSUMPTION" \$16,500 TO 10% MORTGAGE \$67,900 WESTERN GOLD custom built colonial on estate lot. Beautiful new kitchen! Dining room, 1 1/2 baths, central air, basement, attached garage, NEWLY DECORATED! (Very sharp) \$98,900 lot payment 13957 Garfield "JERRY STILL" "JERRY STILL" RE/MAX WEST INC. 261-1400 "ABOVE THE CROWD" In over 40 states, Canada & Hawaii REDFORD TOWNSHIP Beautiful area. Brick with aluminum trim, 3 bedrooms, 1 1/2 baths, 1 1/2 car garage, full finished basement, plus 2nd floor clean, basement, garage and patio. \$67,500. 525-4200 EFA Integrity HURRY! Just redone, 2 bedrooms, den, kitchen, garage, large lot, \$36,900. MASTER ASSOCIATES 478-7550 IMMEDIATE OCCUPANCY Brick ranch in excellent condition with full partially finished basement, 1 1/2 car garage. On large nicely landscaped lot, \$41,000. Executive Realtors 476-5990 LOADED with extras like new counter tops, double sinks in bathroom, fire alarm, sun-room, finished basement with 1/2 bath, 3 bedrooms, large 18 ft. kitchen with lots of cupboards, garage and 13 Month Home Warranty. Priced at \$49,900. Call: BILL PALMER CENTURY 21 Gold House Realtors 420-2100 MAINTENANCE FREE Mint 3 bed room brick ranch, 2 baths, wet plaster, hardwood floors, air conditioned, fully insulated, finished basement, wet bar, 2 car garage. Much more. Open Sat & Sun, 10-5. 537-9118 OPEN SUNDAY 1-5, 24465 Westgate Dr. Prime area 3 bedroom brick ranch, family room, fireplace, 1 1/2 baths, tiled garage. \$74,900. 255-4588 RANCH 3 bedrooms, brick, full bath, large country lot in city. Owner anxious. Call now \$48,900. Norwood, No. 12 North. Inc. 851-7190

319 Homes For Sale Wayne County ASSUME 7 1/2% at \$196 month. 1.96. Telegraph Rd. 2 bedroom brick, possible 3rd bedroom, completely furnished, new appliances, full finished basement, aluminum trim and carpet. Fenced yard. Must sell, \$30,000. 535-1033 STARTER HOME Cherry Hill - Beech Daly area, immaculate 3 bedroom brick ranch, full finished basement, carpet, beautifully decorated, partially finished basement, garage, immediate occupancy. \$41,900. 476-5140 302 Birmingham Bloomfield ADAMS-SQ. LAKE 3 bedroom ranch and 3 acres. 2 family rooms, beautiful trees, landscaping, large stable. Lot can be divided. Bloomfield School District. BLACKWOOD ASSOCIATES INC. 626-8130 ADAMS WOODS BEST VALUE! New ranch comes with Sat & Sun, 1-6pm. 1390 Bramblebush Run (Custom decorated) with many extras. \$139,500. 10% assumable mortgage. 852-6436 BIRMINGHAM Country Club, 3 bedroom, 3 1/2 baths, central air, full finished basement. \$139,900. 852-6436 IMMACULATE! Beautifully built, one-owner, New Orleans colonial 4 bedroom, 2 1/2 baths, large kitchen, tiled bathroom, library, handsome family \$162,500. IN-TOWN SECLUSION! Large quad-level on deep, treed lot close to downtown. Birmingham 5 bedrooms, 3 1/2 baths, fireplace family room, sunken patio. \$227,900. BLOOMFIELD VILLAGE! Pillared colonial with unusual open floor plan perfect for entertaining. 5 bedrooms, 3 full, 2 half baths, family room, library, central air. \$292,500. RALPH MANUEL ASSOCIATES 1821 W Maple 647-7100 Birmingham

319 Homes For Sale Wayne County ASSUME 7 1/2% at \$196 month. 1.96. Telegraph Rd. 2 bedroom brick, possible 3rd bedroom, completely furnished, new appliances, full finished basement, aluminum trim and carpet. Fenced yard. Must sell, \$30,000. 535-1033 STARTER HOME Cherry Hill - Beech Daly area, immaculate 3 bedroom brick ranch, full finished basement, carpet, beautifully decorated, partially finished basement, garage, immediate occupancy. \$41,900. 476-5140 302 Birmingham Bloomfield ADAMS-SQ. LAKE 3 bedroom ranch and 3 acres. 2 family rooms, beautiful trees, landscaping, large stable. Lot can be divided. Bloomfield School District. BLACKWOOD ASSOCIATES INC. 626-8130 ADAMS WOODS BEST VALUE! New ranch comes with Sat & Sun, 1-6pm. 1390 Bramblebush Run (Custom decorated) with many extras. \$139,500. 10% assumable mortgage. 852-6436 BIRMINGHAM Country Club, 3 bedroom, 3 1/2 baths, central air, full finished basement. \$139,900. 852-6436 IMMACULATE! Beautifully built, one-owner, New Orleans colonial 4 bedroom, 2 1/2 baths, large kitchen, tiled bathroom, library, handsome family \$162,500. IN-TOWN SECLUSION! Large quad-level on deep, treed lot close to downtown. Birmingham 5 bedrooms, 3 1/2 baths, fireplace family room, sunken patio. \$227,900. BLOOMFIELD VILLAGE! Pillared colonial with unusual open floor plan perfect for entertaining. 5 bedrooms, 3 full, 2 half baths, family room, library, central air. \$292,500. RALPH MANUEL ASSOCIATES 1821 W Maple 647-7100 Birmingham

319 Homes For Sale Wayne County ASSUME 7 1/2% at \$196 month. 1.96. Telegraph Rd. 2 bedroom brick, possible 3rd bedroom, completely furnished, new appliances, full finished basement, aluminum trim and carpet. Fenced yard. Must sell, \$30,000. 535-1033 STARTER HOME Cherry Hill - Beech Daly area, immaculate 3 bedroom brick ranch, full finished basement, carpet, beautifully decorated, partially finished basement, garage, immediate occupancy. \$41,900. 476-5140 302 Birmingham Bloomfield ADAMS-SQ. LAKE 3 bedroom ranch and 3 acres. 2 family rooms, beautiful trees, landscaping, large stable. Lot can be divided. Bloomfield School District. BLACKWOOD ASSOCIATES INC. 626-8130 ADAMS WOODS BEST VALUE! New ranch comes with Sat & Sun, 1-6pm. 1390 Bramblebush Run (Custom decorated) with many extras. \$139,500. 10% assumable mortgage. 852-6436 BIRMINGHAM Country Club, 3 bedroom, 3 1/2 baths, central air, full finished basement. \$139,900. 852-6436 IMMACULATE! Beautifully built, one-owner, New Orleans colonial 4 bedroom, 2 1/2 baths, large kitchen, tiled bathroom, library, handsome family \$162,500. IN-TOWN SECLUSION! Large quad-level on deep, treed lot close to downtown. Birmingham 5 bedrooms, 3 1/2 baths, fireplace family room, sunken patio. \$227,900. BLOOMFIELD VILLAGE! Pillared colonial with unusual open floor plan perfect for entertaining. 5 bedrooms, 3 full, 2 half baths, family room, library, central air. \$292,500. RALPH MANUEL ASSOCIATES 1821 W Maple 647-7100 Birmingham

319 Homes For Sale Wayne County ASSUME 7 1/2% at \$196 month. 1.96. Telegraph Rd. 2 bedroom brick, possible 3rd bedroom, completely furnished, new appliances, full finished basement, aluminum trim and carpet. Fenced yard. Must sell, \$30,000. 535-1033 STARTER HOME Cherry Hill - Beech Daly area, immaculate 3 bedroom brick ranch, full finished basement, carpet, beautifully decorated, partially finished basement, garage, immediate occupancy. \$41,900. 476-5140 302 Birmingham Bloomfield ADAMS-SQ. LAKE 3 bedroom ranch and 3 acres. 2 family rooms, beautiful trees, landscaping, large stable. Lot can be divided. Bloomfield School District. BLACKWOOD ASSOCIATES INC. 626-8130 ADAMS WOODS BEST VALUE! New ranch comes with Sat & Sun, 1-6pm. 1390 Bramblebush Run (Custom decorated) with many extras. \$139,500. 10% assumable mortgage. 852-6436 BIRMINGHAM Country Club, 3 bedroom, 3 1/2 baths, central air, full finished basement. \$139,900. 852-6436 IMMACULATE! Beautifully built, one-owner, New Orleans colonial 4 bedroom, 2 1/2 baths, large kitchen, tiled bathroom, library, handsome family \$162,500. IN-TOWN SECLUSION! Large quad-level on deep, treed lot close to downtown. Birmingham 5 bedrooms, 3 1/2 baths, fireplace family room, sunken patio. \$227,900. BLOOMFIELD VILLAGE! Pillared colonial with unusual open floor plan perfect for entertaining. 5 bedrooms, 3 full, 2 half baths, family room, library, central air. \$292,500. RALPH MANUEL ASSOCIATES 1821 W Maple 647-7100 Birmingham

319 Homes For Sale Wayne County ASSUME 7 1/2% at \$196 month. 1.96. Telegraph Rd. 2 bedroom brick, possible 3rd bedroom, completely furnished, new appliances, full finished basement, aluminum trim and carpet. Fenced yard. Must sell, \$30,000. 535-1033 STARTER HOME Cherry Hill - Beech Daly area, immaculate 3 bedroom brick ranch, full finished basement, carpet, beautifully decorated, partially finished basement, garage, immediate occupancy. \$41,900. 476-5140 302 Birmingham Bloomfield ADAMS-SQ. LAKE 3 bedroom ranch and 3 acres. 2 family rooms, beautiful trees, landscaping, large stable. Lot can be divided. Bloomfield School District. BLACKWOOD ASSOCIATES INC. 626-8130 ADAMS WOODS BEST VALUE! New ranch comes with Sat & Sun, 1-6pm. 1390 Bramblebush Run (Custom decorated) with many extras. \$139,500. 10% assumable mortgage. 852-6436 BIRMINGHAM Country Club, 3 bedroom, 3 1/2 baths, central air, full finished basement. \$139,900. 852-6436 IMMACULATE! Beautifully built, one-owner, New Orleans colonial 4 bedroom, 2 1/2 baths, large kitchen, tiled bathroom, library, handsome family \$162,500. IN-TOWN SECLUSION! Large quad-level on deep, treed lot close to downtown. Birmingham 5 bedrooms, 3 1/2 baths, fireplace family room, sunken patio. \$227,900. BLOOMFIELD VILLAGE! Pillared colonial with unusual open floor plan perfect for entertaining. 5 bedrooms, 3 full, 2 half baths, family room, library, central air. \$292,500. RALPH MANUEL ASSOCIATES 1821 W Maple 647-7100 Birmingham

319 Homes For Sale Wayne County ASSUME 7 1/2% at \$196 month. 1.96. Telegraph Rd. 2 bedroom brick, possible 3rd bedroom, completely furnished, new appliances, full finished basement, aluminum trim and carpet. Fenced yard. Must sell, \$30,000. 535-1033 STARTER HOME Cherry Hill - Beech Daly area, immaculate 3 bedroom brick ranch, full finished basement, carpet, beautifully decorated, partially finished basement, garage, immediate occupancy. \$41,900. 476-5140 302 Birmingham Bloomfield ADAMS-SQ. LAKE 3 bedroom ranch and 3 acres. 2 family rooms, beautiful trees, landscaping, large stable. Lot can be divided. Bloomfield School District. BLACKWOOD ASSOCIATES INC. 626-8130 ADAMS WOODS BEST VALUE! New ranch comes with Sat & Sun, 1-6pm. 1390 Bramblebush Run (Custom decorated) with many extras. \$139,500. 10% assumable mortgage. 852-6436 BIRMINGHAM Country Club, 3 bedroom, 3 1/2 baths, central air, full finished basement. \$139,900. 852-6436 IMMACULATE! Beautifully built, one-owner, New Orleans colonial 4 bedroom, 2 1/2 baths, large kitchen, tiled bathroom, library, handsome family \$162,500. IN-TOWN SECLUSION! Large quad-level on deep, treed lot close to downtown. Birmingham 5 bedrooms, 3 1/2 baths, fireplace family room, sunken patio. \$227,900. BLOOMFIELD VILLAGE! Pillared colonial with unusual open floor plan perfect for entertaining. 5 bedrooms, 3 full, 2 half baths, family room, library, central air. \$292,500. RALPH MANUEL ASSOCIATES 1821 W Maple 647-7100 Birmingham

319 Homes For Sale Wayne County ASSUME 7 1/2% at \$196 month. 1.96. Telegraph Rd. 2 bedroom brick, possible 3rd bedroom, completely furnished, new appliances, full finished basement, aluminum trim and carpet. Fenced yard. Must sell, \$30,000. 535-1033 STARTER HOME Cherry Hill - Beech Daly area, immaculate 3 bedroom brick ranch, full finished basement, carpet, beautifully decorated, partially finished basement, garage, immediate occupancy. \$41,900. 476-5140 302 Birmingham Bloomfield ADAMS-SQ. LAKE 3 bedroom ranch and 3 acres. 2 family rooms, beautiful trees, landscaping, large stable. Lot can be divided. Bloomfield School District. BLACKWOOD ASSOCIATES INC. 626-8130 ADAMS WOODS BEST VALUE! New ranch comes with Sat & Sun, 1-6pm. 1390 Bramblebush Run (Custom decorated) with many extras. \$139,500. 10% assumable mortgage. 852-6436 BIRMINGHAM Country Club, 3 bedroom, 3 1/2 baths, central air, full finished basement. \$139,900. 852-6436 IMMACULATE! Beautifully built, one-owner, New Orleans colonial 4 bedroom, 2 1/2 baths, large kitchen, tiled bathroom, library, handsome family \$162,500. IN-TOWN SECLUSION! Large quad-level on deep, treed lot close to downtown. Birmingham 5 bedrooms, 3 1/2 baths, fireplace family room, sunken patio. \$227,900. BLOOMFIELD VILLAGE! Pillared colonial with unusual open floor plan perfect for entertaining. 5 bedrooms, 3 full, 2 half baths, family room, library, central air. \$292,500. RALPH MANUEL ASSOCIATES 1821 W Maple 647-7100 Birmingham

319 Homes For Sale Wayne County ASSUME 7 1/2% at \$196 month. 1.96. Telegraph Rd. 2 bedroom brick, possible 3rd bedroom, completely furnished, new appliances, full finished basement, aluminum trim and carpet. Fenced yard. Must sell, \$30,000. 535-1033 STARTER HOME Cherry Hill - Beech Daly area, immaculate 3 bedroom brick ranch, full finished basement, carpet, beautifully decorated, partially finished basement, garage, immediate occupancy. \$41,900. 476-5140 302 Birmingham Bloomfield ADAMS-SQ. LAKE 3 bedroom ranch and 3 acres. 2 family rooms, beautiful trees, landscaping, large stable. Lot can be divided. Bloomfield School District. BLACKWOOD ASSOCIATES INC. 626-8130 ADAMS WOODS BEST VALUE! New ranch comes with Sat & Sun, 1-6pm. 1390 Bramblebush Run (Custom decorated) with many extras. \$139,500. 10% assumable mortgage. 852-6436 BIRMINGHAM Country Club, 3 bedroom, 3 1/2 baths, central air, full finished basement. \$139,900. 852-6436 IMMACULATE! Beautifully built, one-owner, New Orleans colonial 4 bedroom, 2 1/2 baths, large kitchen, tiled bathroom, library, handsome family \$162,500. IN-TOWN SECLUSION! Large quad-level on deep, treed lot close to downtown. Birmingham 5 bedrooms, 3 1/2 baths, fireplace family room, sunken patio. \$227,900. BLOOMFIELD VILLAGE! Pillared colonial with unusual open floor plan perfect for entertaining. 5 bedrooms, 3 full, 2 half baths, family room, library, central air. \$292,500. RALPH MANUEL ASSOCIATES 1821 W Maple 647-7100 Birmingham

302 Birmingham Bloomfield JUST REDUCED - \$134,900 Custom colonial, 3 bedrooms, 2 1/2 baths, superbly maintained, 4th bedroom and bath in professionally finished basement. Formal dining room, island kitchen, breakfast room, entry. Birmingham schools and lake privileges. 661-2881 Birmingham Listings! OPEN KITCHEN - family room contributes great convenience and utility! Quality 3 bedroom brick ranch in quiet Beverly Hills location with low maintenance exterior. Central Air. \$86,000. TREADED LOT highlights this attractive Ranch home with 150 x 240' setting near Branch Rice-Marian 2nd floor. 2 fireplaces, bay windowed dining room, Birmingham Schools. \$193,900. EARL Realty North, Inc. 559-1300 APPEALING 2 bedroom, 1 1/2 bath home close to shops and transportation. Recently redecorated in neutral tones. Great 1 1/2 car garage. Beautiful yard. \$84,900 Ask for: JERRY MC KEON RE/MAX OF Birmingham 647-0500 BIRMINGHAM by owner, choice location. 4 bedrooms, 2 1/2 baths, fireplace in living room, formal dining room, den, large updated kitchen with eating area. Many extras. \$149,500. 642-4769 BIRMINGHAM IN TOWN Attractive well built 3 bedroom Colonial. Excellent family home. Living room with fireplace, dining room, family room, 1 1/2 baths, new central air, fenced yard with patio & privacy fence. 2 1/2 car garage. 1345 Henrietta. By Owner \$99,500. 646-9739 BIRMINGHAM, 1858 Batts, newly decorated 1 1/2 story, 3 bedrooms, new kitchen, family room, sun room, fireplace, \$179,900. Open Sat. & Sun 1-5pm. 644-3621 BIRMINGHAM, 3 bedroom, 1 1/2 baths, 2 car garage, rec room, fireplace, separate dining room, Pembroke Park, \$75,500. Selling only \$69,900. BIRMINGHAM, 3 bedroom, 2 1/2 baths, 1 1/2 car garage, close to downtown. 1487 Ruffner. \$52,500. Call evening. 644-2448 BIRMINGHAM 4 bedroom, 2 1/2 baths, newer kitchen, breakfast room, family study, living room, formal dining room, den, large updated kitchen with eating area. Many extras. \$149,500. 642-4769 BIRMINGHAM TOWNSHIP 3 bed room, 1 1/2 baths, formal dining room, family room, dining room, new deck & gas furnace, completely updated, 4 bedroom, 2 1/2 baths, kitchen, assumable mortgage and privacy. \$69,900. 855-9699 ASK FOR BILL BARBER

302 Birmingham Bloomfield JUST REDUCED - \$134,900 Custom colonial, 3 bedrooms, 2 1/2 baths, superbly maintained, 4th bedroom and bath in professionally finished basement. Formal dining room, island kitchen, breakfast room, entry. Birmingham schools and lake privileges. 661-2881 Birmingham Listings! OPEN KITCHEN - family room contributes great convenience and utility! Quality 3 bedroom brick ranch in quiet Beverly Hills location with low maintenance exterior. Central Air. \$86,000. TREADED LOT highlights this attractive Ranch home with 150 x 240' setting near Branch Rice-Marian 2nd floor. 2 fireplaces, bay windowed dining room, Birmingham Schools. \$193,900. EARL Realty North, Inc. 559-1300 APPEALING 2 bedroom, 1 1/2 bath home close to shops and transportation. Recently redecorated in neutral tones. Great 1 1/2 car garage. Beautiful yard. \$84,900 Ask for: JERRY MC KEON RE/MAX OF Birmingham 647-0500 BIRMINGHAM by owner, choice location. 4 bedrooms, 2 1/2 baths, fireplace in living room, formal dining room, den, large updated kitchen with eating area. Many extras. \$149,500. 642-4769 BIRMINGHAM IN TOWN Attractive well built 3 bedroom Colonial. Excellent family home. Living room with fireplace, dining room, family room, 1 1/2 baths, new central air, fenced yard with patio & privacy fence. 2 1/2 car garage. 1345 Henrietta. By Owner \$99,500. 646-9739 BIRMINGHAM, 1858 Batts, newly decorated 1 1/2 story, 3 bedrooms, new kitchen, family room, sun room, fireplace, \$179,900. Open Sat. & Sun 1-5pm. 644-3621 BIRMINGHAM, 3 bedroom, 1 1/2 baths, 2 car garage, rec room, fireplace, separate dining room, Pembroke Park, \$75,500. Selling only \$69,900. BIRMINGHAM, 3 bedroom, 2 1/2 baths, 1 1/2 car garage, close to downtown. 1487 Ruffner. \$52,500. Call evening. 644-2448 BIRMINGHAM 4 bedroom, 2 1/2 baths, newer kitchen, breakfast room, family study, living room, formal dining room, den, large updated kitchen with eating area. Many extras. \$149,500. 642-4769 BIRMINGHAM TOWNSHIP 3 bed room, 1 1/2 baths, formal dining room, family room, dining room, new deck & gas furnace, completely updated, 4 bedroom, 2 1/2 baths, kitchen, assumable mortgage and privacy. \$69,900. 855-9699 ASK FOR BILL BARBER

302 Birmingham Bloomfield JUST REDUCED - \$134,900 Custom colonial, 3 bedrooms, 2 1/2 baths, superbly maintained, 4th bedroom and bath in professionally finished basement. Formal dining room, island kitchen, breakfast room, entry. Birmingham schools and lake privileges. 661-2881 Birmingham Listings! OPEN KITCHEN - family room contributes great convenience and utility! Quality 3 bedroom brick ranch in quiet Beverly Hills location with low maintenance exterior. Central Air. \$86,000. TREADED LOT highlights this attractive Ranch home with 150 x 240' setting near Branch Rice-Marian 2nd floor. 2 fireplaces, bay windowed dining room, Birmingham Schools. \$193,900. EARL Realty North, Inc. 559-1300 APPEALING 2 bedroom, 1 1/2 bath home close to shops and transportation. Recently redecorated in neutral tones. Great 1 1/2 car garage. Beautiful yard. \$84,900 Ask for: JERRY MC KEON RE/MAX OF Birmingham 647-0500 BIRMINGHAM by owner, choice location. 4 bedrooms, 2 1/2 baths, fireplace in living room, formal dining room, den, large updated kitchen with eating area. Many extras. \$149,500. 642-4769 BIRMINGHAM IN TOWN Attractive well built 3 bedroom Colonial. Excellent family home. Living room with fireplace, dining room, family room, 1 1/2 baths, new central air, fenced yard with patio & privacy fence. 2 1/2 car garage. 1345 Henrietta. By Owner \$99,500. 646-9739 BIRMINGHAM, 1858 Batts, newly decorated 1 1/2 story, 3 bedrooms, new kitchen, family room, sun room, fireplace, \$179,900. Open Sat. & Sun 1-5pm. 644-3621 BIRMINGHAM, 3 bedroom, 1 1/2 baths, 2 car garage, rec room, fireplace, separate dining room, Pembroke Park, \$75,500. Selling only \$69,900. BIRMINGHAM, 3 bedroom, 2 1/2 baths, 1 1/2 car garage, close to downtown. 1487 Ruffner. \$52,500. Call evening. 644-2448 BIRMINGHAM 4 bedroom, 2 1/2 baths, newer kitchen, breakfast room, family study, living room, formal dining room, den, large updated kitchen with eating area. Many extras. \$149,500. 642-4769 BIRMINGHAM TOWNSHIP 3 bed room, 1 1/2 baths, formal dining room, family room, dining room, new deck & gas furnace, completely updated, 4 bedroom, 2 1/2 baths, kitchen, assumable mortgage and privacy. \$69,900. 855-9699 ASK FOR BILL BARBER

302 Birmingham Bloomfield JUST REDUCED - \$134,900 Custom colonial, 3 bedrooms, 2 1/2 baths, superbly maintained, 4th bedroom and bath in professionally finished basement. Formal dining room, island kitchen, breakfast room, entry. Birmingham schools and lake privileges. 661-2881 Birmingham Listings! OPEN KITCHEN - family room contributes great convenience and utility! Quality 3 bedroom brick ranch in quiet Beverly Hills location with low maintenance exterior. Central Air. \$86,000. TREADED LOT highlights this attractive Ranch home with 150 x 240' setting near Branch Rice-Marian 2nd floor. 2 fireplaces, bay windowed dining room, Birmingham Schools. \$193,900. EARL Realty North, Inc. 559-1300 APPEALING 2 bedroom, 1 1/2 bath home close to shops and transportation. Recently redecorated in neutral tones. Great 1 1/2 car garage. Beautiful yard. \$84,900 Ask for: JERRY MC KEON RE/MAX OF Birmingham 647-0500 BIRMINGHAM by owner, choice location. 4 bedrooms, 2 1/2 baths, fireplace in living room, formal dining room, den, large updated kitchen with eating area. Many extras. \$149,500. 642-4769 BIRMINGHAM IN TOWN Attractive well built 3 bedroom Colonial. Excellent family home. Living room with fireplace, dining room, family room, 1 1/2 baths, new central air, fenced yard with patio & privacy fence. 2 1/2 car garage. 1345 Henrietta. By Owner \$99,500. 646-9739 BIRMINGHAM, 1858 Batts, newly decorated 1 1/2 story, 3 bedrooms, new kitchen, family room, sun room, fireplace, \$179,900. Open Sat. & Sun 1-5pm. 644-3621 BIRMINGHAM, 3 bedroom, 1 1/2 baths, 2 car garage, rec room, fireplace, separate dining room, Pembroke Park, \$75,500. Selling only \$69,900. BIRMINGHAM, 3 bedroom, 2 1/2 baths, 1 1/2 car garage, close to downtown. 1487 Ruffner. \$52,500. Call evening. 644-2448 BIRMINGHAM 4 bedroom, 2 1/2 baths, newer kitchen, breakfast room, family study, living room, formal dining room, den, large updated kitchen with eating area. Many extras. \$149,500. 642-4769 BIRMINGHAM TOWNSHIP 3 bed room, 1 1/2 baths, formal dining room, family room, dining room, new deck & gas furnace, completely updated, 4 bedroom, 2 1/2 baths, kitchen, assumable mortgage and privacy. \$69,900. 855-9699 ASK FOR BILL BARBER

302 Birmingham Bloomfield JUST REDUCED - \$134,900 Custom colonial, 3 bedrooms, 2 1/2 baths, superbly maintained, 4th bedroom and bath in professionally finished basement. Formal dining room, island kitchen, breakfast room, entry. Birmingham schools and lake privileges. 661-2881 Birmingham Listings! OPEN KITCHEN - family room contributes great convenience and utility! Quality 3 bedroom brick ranch in quiet Beverly Hills location with low maintenance exterior. Central Air. \$86,000. TREADED LOT highlights this attractive Ranch home with 150 x 240' setting near Branch Rice-Marian 2nd floor. 2 fireplaces, bay windowed dining room, Birmingham Schools. \$193,900. EARL Realty North, Inc. 559-1300 APPEALING 2 bedroom, 1 1/2 bath home close to shops and transportation. Recently redecorated in neutral tones. Great 1 1/2 car garage. Beautiful yard. \$84,900 Ask for: JERRY MC KEON RE/MAX OF Birmingham 647-0500 BIRMINGHAM by owner, choice location. 4 bedrooms, 2 1/2 baths, fireplace in living room, formal dining room, den, large updated kitchen with eating area. Many extras. \$149,500. 642-4769 BIRMINGHAM IN TOWN Attractive well built 3 bedroom Colonial. Excellent family home. Living room with fireplace, dining room, family room, 1 1/2 baths, new central air, fenced yard with patio & privacy fence. 2 1/2 car garage. 1345 Henrietta. By Owner \$99,500. 646-9739 BIRMINGHAM, 1858 Batts, newly decorated 1 1/2 story, 3 bedrooms, new kitchen, family room, sun room, fireplace, \$179,900. Open Sat. & Sun 1-5pm. 644-3621 BIRMINGHAM, 3 bedroom, 1 1/2 baths, 2 car garage, rec room, fireplace, separate dining room, Pembroke Park, \$75,500. Selling only \$69,900. BIRMINGHAM, 3 bedroom, 2 1/2 baths, 1 1/2 car garage, close to downtown. 1487 Ruffner. \$52,500. Call evening. 644-2448 BIRMINGHAM 4 bedroom, 2 1/2 baths, newer kitchen, breakfast room, family study, living room, formal dining room, den, large updated kitchen with eating area. Many extras. \$149,500. 642-4769 BIRMINGHAM TOWNSHIP 3 bed room, 1 1/2 baths, formal dining room, family room, dining room, new deck & gas furnace, completely updated, 4 bedroom, 2 1/2 baths, kitchen, assumable mortgage and privacy. \$69,900. 855-9699 ASK FOR BILL BARBER

302 Birmingham Bloomfield JUST REDUCED - \$134,900 Custom colonial, 3 bedrooms, 2 1/2 baths, superbly maintained, 4th bedroom and bath in professionally finished basement. Formal dining room, island kitchen, breakfast room, entry. Birmingham schools and lake privileges. 661-2881 Birmingham Listings! OPEN KITCHEN - family room contributes great convenience and utility! Quality 3 bedroom brick ranch in quiet Beverly Hills location with low maintenance exterior. Central Air. \$86,000. TREADED LOT highlights this attractive Ranch home with 150 x 240' setting near Branch Rice-Marian 2nd floor. 2 fireplaces, bay windowed dining room, Birmingham Schools. \$193,900. EARL Realty North, Inc. 559-1300 APPEALING 2 bedroom, 1 1/2 bath home close to shops and transportation. Recently redecorated in neutral tones. Great 1 1/2 car garage. Beautiful yard. \$84,900 Ask for: JERRY MC KEON RE/MAX OF Birmingham 647-0500 BIRMINGHAM by owner, choice location. 4 bedrooms, 2 1/2 baths, fireplace in living room, formal dining room, den, large updated kitchen with eating area. Many extras. \$149,500. 642-4769 BIRMINGHAM IN TOWN Attractive well built 3 bedroom Colonial. Excellent family home. Living room with fireplace, dining room, family room, 1 1/2 baths, new central air, fenced yard with patio & privacy fence. 2 1/2 car garage. 1345 Henrietta. By Owner \$99,500. 646-9739 BIRMINGHAM, 1858 Batts, newly decorated 1 1/2 story, 3 bedrooms, new kitchen, family room, sun room, fireplace, \$179,900. Open Sat. & Sun 1-5pm. 644-3621 BIRMINGHAM, 3 bedroom, 1 1/2 baths, 2 car garage, rec room, fireplace, separate dining room, Pembroke Park, \$75,500. Selling only \$69,900. BIRMINGHAM, 3 bedroom, 2 1/2 baths, 1 1/2 car garage, close to downtown. 1487 Ruffner. \$52,500. Call evening. 644-2448 BIRMINGHAM 4 bedroom, 2 1/2 baths, newer kitchen, breakfast room, family study, living room, formal dining room, den, large updated kitchen with eating area. Many extras. \$149,500. 642-4769 BIRMINGHAM TOWNSHIP 3 bed room, 1 1/2 baths, formal dining room, family room, dining room, new deck & gas furnace, completely updated, 4 bedroom, 2 1/2 baths, kitchen, assumable mortgage and privacy. \$69,900. 855-9699 ASK FOR BILL BARBER

302 Birmingham Bloomfield JUST REDUCED - \$134,900 Custom colonial, 3 bedrooms, 2 1/2 baths, superbly maintained, 4th bedroom and bath in professionally finished basement. Formal dining room, island kitchen, breakfast room, entry. Birmingham schools and lake privileges. 661-2881 Birmingham Listings! OPEN KITCHEN - family room contributes great convenience and utility! Quality 3 bedroom brick ranch in quiet Beverly Hills location with low maintenance exterior. Central Air. \$86,000. TREADED LOT highlights this attractive Ranch home with 150 x 240' setting near Branch Rice-Marian 2nd floor. 2 fireplaces, bay windowed dining room, Birmingham Schools. \$193,900. EARL Realty North, Inc. 559-1300 APPEALING 2 bedroom, 1 1/2 bath home close to shops and transportation. Recently redecorated in neutral tones. Great 1 1/2 car garage. Beautiful yard. \$84,900 Ask for: JERRY MC KEON RE/MAX OF Birmingham 647-0500 BIRMINGHAM by owner, choice location. 4 bedrooms, 2 1/2 baths, fireplace in living room, formal dining room, den, large updated kitchen with eating area. Many extras. \$149,500. 642-4769 BIRMINGHAM IN TOWN Attractive well built 3 bedroom Colonial. Excellent family home. Living room with fireplace, dining room, family room, 1 1/2 baths, new central air, fenced yard with patio & privacy fence. 2 1/2 car garage. 1345 Henrietta. By Owner \$99,500. 646-9739 BIRMINGHAM, 1858 Batts, newly decorated 1 1/2 story, 3 bedrooms, new kitchen, family room, sun room, fireplace, \$179,900. Open Sat. & Sun 1-5pm. 644-3621 BIRMINGHAM, 3 bedroom, 1 1/2 baths, 2 car garage, rec room, fireplace, separate dining room, Pembroke Park, \$75,500. Selling only \$69,900. BIRMINGHAM, 3 bedroom, 2 1/2 baths, 1 1/2 car garage, close to downtown. 1487 Ruffner. \$52,500. Call evening. 644-2448 BIRMINGHAM 4 bedroom, 2 1/2 baths, newer kitchen, breakfast room, family study, living room, formal dining room, den, large updated kitchen with eating area. Many extras. \$149,500. 642-4769 BIRMINGHAM TOWNSHIP 3 bed room, 1 1/2 baths, formal dining room, family room, dining room, new deck & gas furnace, completely updated, 4 bedroom, 2 1/2 baths, kitchen, assumable mortgage and privacy. \$69,900. 855-9699 ASK FOR BILL BARBER

302 Birmingham Bloomfield JUST REDUCED - \$134,900 Custom colonial, 3 bedrooms, 2 1/2 baths, superbly maintained, 4th bedroom and bath in professionally finished basement. Formal dining room, island kitchen, breakfast room, entry. Birmingham schools and lake privileges. 661-2881 Birmingham Listings! OPEN KITCHEN - family room contributes great convenience and utility! Quality 3 bedroom brick ranch in quiet Beverly Hills location with low maintenance exterior. Central Air. \$86,000. TREADED LOT highlights this attractive Ranch home with 150 x 240' setting near Branch Rice-Marian 2nd floor. 2 fireplaces, bay windowed dining room, Birmingham Schools. \$193,900. EARL Realty North, Inc. 559-1300 APPEALING 2 bedroom, 1 1/2 bath home close to shops and transportation. Recently redecorated in neutral tones. Great 1 1/2 car garage. Beautiful yard. \$84,900 Ask for: JERRY MC KEON RE/MAX OF Birmingham 647-0500 BIRMINGHAM by owner, choice location. 4 bedrooms, 2 1/2 baths, fireplace in living room, formal dining room, den, large updated kitchen with eating area. Many extras. \$149,500. 642-4769 BIRMINGHAM IN TOWN Attractive well built 3 bedroom Colonial. Excellent family home. Living room with fireplace, dining room, family room, 1 1/2 baths, new central air, fenced yard with patio & privacy fence. 2 1/2 car garage. 1345 Henrietta. By Owner \$99,500. 646-9739 BIRMINGHAM, 1858 Batts, newly decorated 1 1/2 story, 3 bedrooms, new kitchen, family room, sun room, fireplace, \$179,900. Open Sat. & Sun 1-5pm. 644-3621 BIRMINGHAM, 3 bedroom, 1 1/2 baths, 2 car garage, rec room, fireplace, separate dining room, Pembroke Park, \$75,500. Selling only \$69,900. BIRMINGHAM, 3 bedroom, 2 1/2 baths, 1 1/2 car garage, close to downtown. 1487 Ruffner. \$52,500. Call evening. 644-2448 BIRMINGHAM 4 bedroom, 2 1/2 baths, newer kitchen, breakfast room, family study, living room, formal dining room, den, large updated kitchen with eating area. Many extras. \$149,500. 642-4769 BIRMINGHAM TOWNSHIP 3 bed room, 1 1/2 baths, formal dining room, family room,

**304 Farmington Farmington Hills**

**HAMMOCK TIME**  
Move right in - this home has pride of ownership displayed and allows you lots of hammock time. 4 bedrooms including a warm master bedroom with bath, a charming family room that unfolds to a patio through the door and a deck enfolds the huge oak trees. Shown by appointment call Lynn McGowan, 851-5700. Century 21 Neighborhood Realty

**ROOM TO GROW**

**OPEN SAT. 2-5**  
62 at 23151 ALBERTA, N. of Shawnee see W of Middlebelt. Immaculate 1 bedroom home on triple lot superbly cared for. Heated garage with workshop and carport. Washer, dryer, air conditioner. Seller will leave builder's plans for second story addition \$42,900.

**Century 21**  
VINCENT N. LEE  
EXECUTIVE TRANSFER SALES  
**851-4100**

**RURAL RANCH**  
Only one year old with 10 1/2 acres to see. This 3 bedroom aluminum sided ranch home. Featuring a country size kitchen with doorway to 80 ft. tree lot, full insulation, 2 car attached garage and a rural area. \$53,900.  
HARRY'S

**WOLFE COMPANY**  
31233 Sevens Mile  
474-5700

**SHARP STARTER HOME**  
IN MOVE IN CONDITION  
Three (3) bedrooms, full basement, garage. Walk to shopping. V.A. terms, new size roof. Call Bert Jones 537-9000. Call Bert Jones 537-9000.

**Thompson-Brown**

**OPEN SAT.-SUN. 2-5**  
Farmington Hills  
JUST LISTED - Two (2) brand new four (4) bedroom ranches on 1/2 acre wooded lots. These spacious homes feature island kitchens, no-wax floors, 2 1/2 baths, custom stained woodwork, custom cabinets, generous carpeting, sod and fixture allowances plus much more. Traditional Country Model - \$132,900... California Contemporary - \$137,900, 25462 and 25440 Springbrook - S. of 11 Mile, W. of Middlebelt.

**Century 21**  
ROBEC PROPERTIES  
851-7711

**OPEN SUN. 1-5**  
LARGE COLONIAL on nicely landscaped lot on cul-de-sac. 4 bedrooms, 2 1/2 baths, family room, brick patio. \$94,900. 24155 ST. MARVIS CT. S. off 10 Mile E. of Farmington Hills.

**Chamberlain**  
626-9100

**OPEN SUN. 4-7**  
Absolutely magnificent hilltop residence on one of Rolling Oaks largest & peer trees. Situated on a cul-de-sac, this large 4 bedroom colonial is positively guaranteed to "take your breath away." It features neutral decor and outstanding landscaping around two circles, more than just an opportunity! Do not let it go by. \$149,900. 10974 Sutters Hill Ct. off Farmington Hills just S of 14 Mile.

**Century 21**  
ROBEC PROPERTIES  
851-7711

**OPEN SUN. 2-5**  
3 bedroom, 2 1/2 bath brick ranch, central air, maintenance free finished basement. 2 1/2 car garage. Immediate occupancy. \$81,900.  
ASK FOR MARCO (C) 851-6004

**THE DURBIN**  
COMPANY REALTORS  
Your Neighborhood Broker

**OPEN SUN. 2-5**  
31225 Lee Lane, S. of 10 E. of Orchard Lake. GI - FHA Buyers. 11 1/2% Money.  
New 3 bedroom quads with family room and brick wall fireplaces, deluxe kitchens with dinettes. Fantastic value \$78,900.  
Call Marsha Thomas 851-6004

**THE DURBIN**  
COMPANY REALTORS  
Your Neighborhood Broker

**305 Brighton-Hartland**  
JUST REDUCED! Possible in-law quarters in this \$600 sq. ft. home on 2 1/2 acres, 2 kitchens, 2 1/2 baths, 2 fireplaces. 24x29 cement block barn. Borden state land. Pinckney Schools. A tune home for \$94,900.

**REDUCED! FOR QUICK SALE!** Very nice 3 bedroom b-level in lovely area of Hartland. Fireplace in family room, den could be 4th bedroom, 2 car garage, gas heat, immediate occupancy. Simple assumption of mortgage possible. Only \$69,900.  
ENGLAND REAL ESTATE  
632-7427 474-4530

**BRIGHTON** by owner. 3 bedroom ranch family room with fireplace, finished basement, 2 1/2 car garage. lake privileges \$79,500. Simple assumption or terms available. 229-4828

**BRIGHTON** Rec area. Immaculate 2 year old custom quad level with walk-out on 5 acres with paved road. Many extras in area of \$160,900. \$178,641. By owner. \$114,900 878-6661

**306 Southfield-Lathrup**

**REDUCED TO SELL**  
3 bedroom, fireplace in living room, full basement, garage, central air, in-law suite. \$47,900. Assumable 8 1/2% mortgage, land contract or VA financing available. Tom Adler Realty 632-8222. Evenings 626-3837

**SOUTHFIELD** by owner. 5 of 10 W. of Greenfield, 577-3178 or 557-2408

**SOUTHFIELD** by owner. Must sell, relocate. Trs. 27406 Marshall & Greenfield. Spacious 4 bedroom colonial, 2100 sq. ft., 2 1/2 baths, 2 car attached garage, 25 ft. paneled family room, 25 ft. master bedroom, central air, 19 1/2 ft. concrete driveway. 11 X 22 patio \$78,900. Assumable mortgage. 649-4040

**SOUTHFIELD FIXER** - 3 1/2 family room. Bring brush, real thousands. Open Sat. 1-4 PM. 29672 Marshall Southfield. Ask for Janet Still. 891-9900 or 476-8115. Real Estate One.

**OPEN SUNDAY 1-4 PM**  
28990 MONTEREY - w/ spacious rooms. Please note this 26 ft. family room with fireplace, 17 ft. master bedroom, 2 more bedrooms, full dining room and attached 2 car garage with electric door opener. \$81,400. In lot in Southfield's Greentree \$83,900. 557-3200

**BRIGHTON** by owner. 3 bedroom ranch on acre lot with low taxes close to schools, church, freeway. Central air, fireplace, family room, covered patio. Attached garage. \$78,900. 356-7152

**Thompson-Brown**

**306 Southfield-Lathrup**

BY OWNER 6 bedroom brick & stone, 2 car garage, fireplace and barbecue in recreation room. \$130,000. Tree lot. \$51,900. Land contract. \$130,000. 517-548-3250. Southfield, 356-2467

**CHARMING COLONIAL**

Elegant 4 bedroom colonial in a nice location features 2 1/2 baths, formal dining room, very private 2 car garage, car attached garage, nicely landscaped lot with patio. \$89,884  
O'RILEY REALTY 689-8844

**CRANBROOK VILLAGE**, spacious colonial, fireplace, full basement, large bedrooms, \$86,500 by owner. 559-7022

**ENGLISH LIVING**

One of a kind Has Living room with fireplace, formal dining room & den, 3 bedrooms, basement, 2 car garage. Excellent location. \$69,500. Rose Robertson Realtors. For details call Ted Winship. 549-4005

**GREAT FAMILY HOME**, 11 room house, w/ fireplace, microwave, washer, dryer, car attached garage, 2 1/2 car attached garage, 2 bedrooms, family room, carpeted throughout. Breeseva, oversized 2 car garage and more. \$36,500.

**LAHSER/12 Mile**, 4 bedroom Colonial, central air, fireplace, 2 1/2 baths, 2 car garage. Must see! Assumable or L.C. Must see! Assumable or L.C. \$54-5284

**LAHSER 12-MILE**  
OPEN SUN 2-5 PM

29085 Murray Crescent, N off 12 Mile, 1 block E. of Greenfield. New 4 bedroom colonial on large prime lot. custom features, including carpeting, insulated glass, no wax flooring, family room with fireplace, microwave oven, ceramic tile baths, and more. Priced from \$115,000 August occupancy in-time for school.

**JOHN CORPORATION BUILDERS**  
647-5856

**NINE MILE**

Near Southfield Beautiful California Colonial on 1 1/2 acres of park like setting, 2300 sq. ft. of elegance 2 1/2 baths, family room, Florida room, roned heating, enormous 200 sq. ft. modern kitchen and lots of extras. Call for appointment.

**Century 21**  
TODAY 559-4488

**OPEN SUNDAY**  
OWNER ANXIOUS TO SELL!  
Assumable Mortgage or possible Land Contract terms. Love and Care are evident in this 3 bedroom Ranch with 1 1/2 baths, family room and central air.  
23810 Edinburgh, N. of 9 Mile, W. of Telegraph, \$68,400.

**Century 21**  
ROBEC PROPERTIES  
642-2550

**OPEN SUNDAY 1-5**  
3 bedroom custom brick, 2 1/2 bathrooms, central air, wet plaster, fenced yard. Immediate occupancy \$73,900. 18185 New West, off 28th & 19 Mile, W. of Southfield.

**OPEN SUNDAY 2-5**  
17380 Evans in Southfield, S. of 13 Mile and E. of Southfield. Charming brick Ranch in Pinewood Manor with 3 bedrooms, 1 1/2 baths, family room with fireplace, finished rec room with bar, 2 car garage, huge patio, assumable mortgage. \$73,900.

**EARL KEIM**  
Realty North, Inc. 559-1300

**OPEN SUN. 2-5**  
CONTEMPORARY eastside decor highlights this fine 3 bedroom ranch in Cambridge Village. Cathedral beamed ceiling in living room, Central Air, fireplace, 2 1/2 baths, N. of 12 Mile, W. of Greenfield. \$61,900.  
ASK FOR BOOTS HIGGINS

**Chamberlain**  
626-9100

**OPEN SUN. 2-5**  
2743 SHAGBARK, N. of 11 Mile, E. of Southfield. Beautiful Cambridge Village 3 bedroom ranch, country kitchen, dinette, 1 1/2 baths, 2 natural fireplaces, oversized 2 car garage, appliances included. FHA or VA terms. \$84,900.

**Century 21**  
TODAY 559-4488

**OPEN SUN. 2-5**  
29933 ROSEMONT, Franklin Rd. Northwestern Hwy area. COUNTRY CHARMER! Heavily done, privacy, 3 bedroom brick with basement, 2 1/2 baths, large closets, dining room, 2 natural fireplaces, huge enclosed patio for entertaining. Country kitchen with built-in, oven range and brick wall. Newer gas furnace with central air. 2 car attached garage. Its all here! Move right in! \$88,900.  
ASK FOR IRENE GORDON

**Chamberlain**  
626-9100

**POOL PARTIES** - will be a Snap. Beautiful in-ground pool, lovely patio and separate cabana for girls and boys. Impressive brick Colonial, full dining room, kitchen with built-ins, fireplace, family room and 1st floor laundry. 4 bedrooms, 2 1/2 baths, finished basement and attached 2 car garage with electric door opener. Lovely landscaped family room. Lathrup Village. \$99,900. 557-3500.

**MEDITERRANEAN** - Style Custom-built, brick Ranch with 2300 sq. ft. on private street in beautiful Lathrup Village. Central air, 24' carpeted living room, fireplace, family room and kitchen with separate breakfast area, 1st floor laundry, 2 full baths & 2 half baths. Basement, attached double garage and circle drive. Built in 1974. \$131,900. 557-3500.

**Chamberlain**  
557-3500

**REDUCED TO SELL**  
3 bedroom, fireplace in living room, full basement, garage, central air, in-law suite. \$47,900. Assumable 8 1/2% mortgage, land contract or VA financing available. Tom Adler Realty 632-8222. Evenings 626-3837

**SOUTHFIELD** by owner. 5 of 10 W. of Greenfield, 577-3178 or 557-2408

**SOUTHFIELD** by owner. Must sell, relocate. Trs. 27406 Marshall & Greenfield. Spacious 4 bedroom colonial, 2100 sq. ft., 2 1/2 baths, 2 car attached garage, 25 ft. paneled family room, 25 ft. master bedroom, central air, 19 1/2 ft. concrete driveway. 11 X 22 patio \$78,900. Assumable mortgage. 649-4040

**Chamberlain**  
557-3500

**OPEN SUNDAY 1-4 PM**  
28990 MONTEREY - w/ spacious rooms. Please note this 26 ft. family room with fireplace, 17 ft. master bedroom, 2 more bedrooms, full dining room and attached 2 car garage with electric door opener. \$81,400. In lot in Southfield's Greentree \$83,900. 557-3200

**BRIGHTON** by owner. 3 bedroom ranch on acre lot with low taxes close to schools, church, freeway. Central air, fireplace, family room, covered patio. Attached garage. \$78,900. 356-7152

**Chamberlain**  
646-6000

**BRIGHTON** Rec area. Immaculate 2 year old custom quad level with walk-out on 5 acres with paved road. Many extras in area of \$160,900. \$178,641. By owner. \$114,900 878-6661

**306 Southfield-Lathrup**

**SOUTHFIELD**  
Immaculate 3 bedroom Colonial in move-in condition with 1 1/2 baths, country kitchen, floor to ceiling brick fireplace in family room, patio, land contract terms. \$55,900.  
EARL KEIM  
538-8300  
REDFORD INC.

**YOUNG COUPLES**

Here's A SHARP & IMMACULATE Aluminum Starter home PRICED TO SELL! Features 4 bedrooms, full bath, tiled floor in nice area of Southfield 2 bedrooms, family room, carpeted throughout. Breeseva, oversized 2 car garage and more. \$36,500.

**Chamberlain**  
646-6000

**OPEN SUN. 2-4**  
3094 OTTER - TROY N. of Big Beaver, between John R. & Dequindre. 2 bedroom, 2 1/2 baths, above ground pool, underground sprinkling system and more. \$79,900.

**SOMERSET**  
REAL ESTATE  
649-6800

**OPEN SUN. 2-5**  
2376 HEMSTEAD-AUBURN HTS. N. of South Blvd. E. of Opdyke. Owner anxious, sharp 3 bedroom brick ranch, 1 1/2 baths, family room w/ fireplace, full basement & screened porch. Price reduced - \$61,900.

**SOMERSET**  
REAL ESTATE  
649-6800

**PROFESSIONALLY LANDSCAPED 3** bedroom ranch Walk to schools. Extras include aluminum trim, underground sprinkling system, central air, full 1st floor laundry and living room, no-wax kitchen floor and more. \$92,900.

**Chamberlain**  
689-8900

**ROCHESTER** attractive 3 bedroom ranch in quiet, well kept neighborhood. Newly redecorated kitchen with built-ins, family room, cheerfull living room. 2 1/2 baths. \$51,5895.  
ASK FOR GORDON FOX

**Chamberlain**  
689-8900

**ROCHESTER** brick ranch built by Sidney Weinberger 3 bedrooms, 2 1/2 baths, full basement, fireplace, full basement on half acre lot.

**Chamberlain**  
689-8900

**ROCHESTER** by owner. 1 year old, 4 bedroom, den, 2 1/2 bath brick colonial. 1st floor laundry, deck, sprinkler system, backs to lake. \$119,900. 286 W. F. Chamberlain

**ROCHESTER** by owner. 2 1/2 sq. ft. 4 bedroom custom brick, 2 1/2 baths, full basement, 1st floor laundry, 2 car garage, assumable mortgage. \$119,900. 375-0349

**ROCHESTER** - by owner. 1 year old, 4 bedroom, den, 2 1/2 bath brick colonial. 1st floor laundry, deck, sprinkler system, backs to lake. \$119,900. 286 W. F. Chamberlain

**Chamberlain**  
689-8900

**ROCHESTER** 8 1/2% Assumable Charming 4 bedroom Colonial on lovely wooded landscaped lot. Formal living room, dining room, modern kitchen breakfast room, 2 1/2 baths, overlooking woods, library, family room w/ fireplace, large over w/ winding staircase. In \$140,000's. 375-0395

**Chamberlain**  
689-8900

**TRIOY BY OWNER**, Professionally decorated, Silicon Glen, 3 bedroom family room, fireplace, 1st floor laundry, dry, air, sprinkler, patio \$107,900. Immediate occupancy. 879-7047

**TRIOY BY OWNER**, 4 bedroom colonial, 2 1/2 baths, air, intercom, central air, alarm, redwood deck, many extras \$107,500. 879-6738

**TRIOY Secluded 3 bedroom Colonial** on Court, 1 1/2 baths, sprinkler, garage, oven, humidor, dog run Near Elementary School. \$87,500. off 689-6764

**TRIOY - GREENTREES SUB** 5 bedrooms or 4 bedrooms & den on 5 1/2 acres, 2 1/2 car size garage with opener, fireplace family room, finished basement with wet bar, carpeted over hardwood flooring, attic, pool, patio with built in barbecue, \$125,900. 4234 Brandynway. Call evenings. 643-7966. Shown by appointment only

**Chamberlain**  
689-8900

**TRIOY - ideal floor plan, spacious quad** on nicely landscaped lot. 3 bedrooms, 2 1/2 baths, 33 ft. family room, excellent value! \$99,500

**SOMERSET**  
REAL ESTATE  
649-6800

**TRIOY in Cypress Garden** 4 bedroom b-level, wooded lot on cul de sac. 2 full baths, family room with fireplace, 2 car garage, gourmet kitchen, excellent value. 75% assumption available. \$87,900. Owner. 689-8746

**TRIOY - OPEN SUN. 2-5**  
Trees, trees, and a gardener's delight! Close to city conveniences. Included with this large lot is an immaculate 3 bedroom, 2 1/2 bath, brick and stone colonial. Close to 175, with Troy schools. \$92,000.

**6050 Elmour** - N off Square Lake Road, between Crooks and Livernois. Max  
**BROOCK**  
626-4000

**NATURE LOVERS DELIGHT**  
Spacious 4 bedroom brick colonial on approximately 1 1/2 acre wooded lot. Private and serene in an elegant, established neighborhood in beautiful Southfield. Immaculate occupancy. \$175,000. Shown by appointment only. Call owner. 641-7155

**NEW ROCHESTER COLONIAL**

Custom home built by Sidney Weinberger, 2700 sq. ft. 4 bedrooms, 2 1/2 baths, full basement, premium wood lot, library with wet bar, full basement, beamed family room with natural fireplace. Professionally landscaped & sodded with red wood deck off pool. Subdivision amenities include tennis court, tennis court, 4 acre wooded park, sidewalks. Prime, close in location \$162,900.

**Chamberlain**  
644-3633

**MUST SELL 4 bedroom colonial** with intrinsic features a buyer seeks. Location, quality care. Real Estate One, Ed Cahill. 528-1300

**Chamberlain**  
646-6000

**TRIOY RANCH**  
Lovely 3 bedroom brick on well landscaped large lot in nice area featuring 1 1/2 baths, full basement & 2 car garage. Call for details & private showing. O'RILEY REALTY 689-8844

**308 Rochester-Troy**

**OPEN SUN. July 20, 2-5**, 852 Gann Rd. The family home with everything 3 bedrooms, 2 1/2 baths. Only \$139,900. L.C. Terms available. N. on Rochester Rd. on Gann Rd. 641-8191. Evans & Assoc. Inc.

**Chamberlain**  
646-6000

**OPEN SUN. 2-4**  
POPULAR family room Colonial First floor laundry, Central Air, 5155 Blair, N. of Long Lake, E. of John R. \$87,900. ASK FOR ROSEANNE STEALE.

**Chamberlain**  
689-8900

**WOOD DECK & EXTRA PATIO** are just a few of the extra features in this lovely 4 bedroom, 2 1/2 bath. Fireplace, large family room, 2 car attached garage with opener. Only \$105,900.

**Chamberlain**  
689-8900

**11% MORTGAGE AVAILABLE** on this beautiful 3 bedroom, 1 1/2 bath, family room with fireplace & built-in, 2 car garage, full basement, all appliances. Lovingly finished. Immediate occupancy. \$89,500. 681-9630.

**WONDERFUL NEIGHBORHOOD** - immaculate 3 bedroom, 1 1/2 bath, family room with fireplace & built-in, 2 car garage, full basement, all appliances. Lovingly finished. Immediate occupancy. \$89,500. 681-9630.

**Chamberlain**  
689-8900

**VERY CLEAN 3 bedroom ranch** in Stonebridge Sub on premium, fenced, corner lot. 2 car attached garage, deck with garden, ac, more. Only \$75,500.

**Chamberlain**  
689-8900

**BEAT THE SUMMER HEAT**, enjoy the privacy of your own 16x24 inground pool. Features 4 bedrooms, 2 1/2 baths, a remodeled 3 bedroom Dutch Colonial with natural fireplace on beautiful tree lot, 626 S. Alexander, Royal Oak. Mid 50's after 5 PM. 547-7635

**Chamberlain**  
689-8900

**ROCHESTER** attractive 3 bedroom ranch in quiet, well kept neighborhood. Newly redecorated kitchen with built-ins, family room, cheerfull living room. 2 1/2 baths. \$51,5895.  
ASK FOR GORDON FOX

**Chamberlain**  
689-8900

**ROCHESTER** brick ranch built by Sidney Weinberger 3 bedrooms, 2 1/2 baths, full basement, fireplace, full basement on half acre lot.

**Chamberlain**  
689-8900

**ROCHESTER** by owner. 2 1/2 sq. ft. 4 bedroom custom brick, 2 1/2 baths, full basement, 1st floor laundry, 2 car garage, assumable mortgage. \$119,900. 375-0349

**ROCHESTER** - by owner. 1 year old, 4 bedroom, den, 2 1/2 bath brick colonial. 1st floor laundry, deck, sprinkler system, backs to lake. \$119,900. 286 W. F. Chamberlain

**ROCHESTER** 8 1/2% Assumable Charming 4 bedroom Colonial on lovely wooded landscaped lot. Formal living room, dining room, modern kitchen breakfast room, 2 1/2 baths, overlooking woods, library, family room w/ fireplace, large over w/ winding staircase. In \$140,000's. 375-0395

**Chamberlain**  
689-8900

**TRIOY BY OWNER**, Professionally decorated, Silicon Glen, 3 bedroom family room, fireplace, 1st floor laundry, dry, air, sprinkler, patio \$107,900. Immediate occupancy. 879-7047

**TRIOY BY OWNER**, 4 bedroom colonial, 2 1/2 baths, air, intercom, central air, alarm, redwood deck, many extras \$107,500. 879-6738

**TRIOY Secluded 3 bedroom Colonial** on Court, 1 1/2 baths, sprinkler, garage, oven, humidor, dog run Near Elementary School. \$87,500. off 689-6764

**TRIOY - GREENTREES SUB** 5 bedrooms or 4 bedrooms & den on 5 1/2 acres, 2 1/2 car size garage with opener, fireplace family room, finished basement with wet bar, carpeted over hardwood flooring, attic, pool, patio with built in barbecue, \$125,900. 4234 Brandynway. Call evenings. 643-7966. Shown by appointment only

**Chamberlain**  
689-8900

**TRIOY - ideal floor plan, spacious quad** on nicely landscaped lot. 3 bedrooms, 2 1/2 baths, 33 ft. family room, excellent value! \$99,500

**SOMERSET**  
REAL ESTATE  
649-6800

**TRIOY in Cypress Garden** 4 bedroom b-level, wooded lot on cul de sac. 2 full baths, family room with fireplace, 2 car garage, gourmet kitchen, excellent value. 75% assumption available. \$87,900. Owner. 689-8746

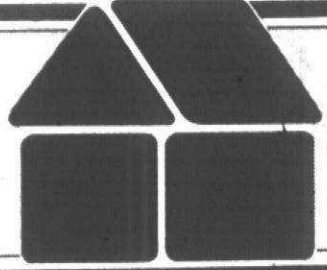

# CLASSIFIED REAL ESTATE

**322 Condominiums For Sale**

**1 1/4 %**  
30 YEAR MORTGAGE  
As Low As 5% DOWN  
**WESTLAND**  
CLOSING OUT  
**CAROLAN CONDOS**  
New 2 Bedroom Units  
From \$45,400 to \$47,900  
Also 1 Ranch Unit, 1 Bedroom - \$49,900  
NOW OPEN - Indoor & Outdoor  
Clubhouse Swimming Pool  
FORD ROAD AND HWY  
OPEN 1-8PM DAILY  
**721-2890**  
If no answer, call 973-1378

**322 Condominiums For Sale**

**QUIET**  
Barkridge Glen in Westland 2 bedroom in courtlocation Sparkling clean, all appliances & private brick patio \$48,500 Ask for Joan Brandt.

**REALTY WORLD**  
Wm. Decker, Inc.  
455-8400

**ROCHESTER** Oak Brook East, 3 bedroom 2 1/2 bath, finished basement, wooded area 10% Assumable \$68,900 652-9331

- **ROCHESTER** -  
**OPEN SUN. 1-4PM**  
1291 Oakwood Ct., N. of University & E. of Livernois Esquisite 3 bedroom, 2 1/2 bath Condo located within the much sought-after Fairwood Villa Complex, which adjoins Great Oaks Country Club. Walking distance from downtown. Professionally decorated thru-out including basement. This property offers the ultimate in Condominium living at an affordable price. SEE YOU SUNDAY!  
**Bollinger & Assoc.**  
- 644-3790 -

**SPACIOUS BRICK AND ALUMINUM CONDO** in Bloomfield Hills 3 bedrooms, 2 1/2 baths, family room with fireplace, enclosed patio, pool and more \$107,900

**ROCHESTER STREAMWOOD**  
Beautiful condo near I-75 & M-59. Two 1 1/2 large bedrooms, dining room, living room, laundry room, central air, drapes & appliances, landscaped patio, garage, plenty of storage. Clubhouse, Tennis & Pool. \$63,900 Assumable. After 4pm. 652-4704

**Chamberlain**  
689-8900

**322 Condominiums For Sale**

**ROCHESTER TO SETTLE ESTATE**  
Popular KINGS COVE. Lovely 2 bedroom, full bath plus lav on second floor. Large living room, first floor lav, full basement, nice carpeting throughout, all kitchen appliances, 1 car attached garage, patio. Vacant. Priced below market value at \$89,900.

**CENTURY 21 SECANTINE ASSOC.**  
626-8800

**ROYAL OAK TOWNHOUSE**  
2 bedrooms Excellent location. Assumption or new mortgage \$39,900 879-1233

SAVE, by owner, condo, 3 bedrooms, 1 1/2 baths, Highland Lakes, Northville 7 1/2 mortgage, appliances, air conditioning, patio grill, fireplace, plenty of parking. \$61,900 349-4042

**SOUTHFIELD OPEN SUN. 2-5PM**  
26550 Inkster, S. of I 11 Mile, E. of Inkster, Cumberland. Owner leaving State. Land Contract terms available. Gorgeous contemporary 3 bedroom, 2 1/2 baths. Finished family room, best parking. Pool and tennis. Priced in the 80's.

**AETNA**  
626-4800

**322 Condominiums For Sale**

**SPACIOUS GROUNDS SURROUND**  
This 2 bedroom, 1 1/2 bath unit in Bedford Villas, Western Wayne County's finest value. Attached garage, full basement, central air, 2 doorways, private patio and super 7 1/2 simple assumption. Only \$54,500 Call 459-3700

**Realty World**  
CHAIPMAN WEST

**STERLING HEIGHTS**, 2 bedroom condo, 2 baths, kitchen appliances, central air. \$58,900 Call after 6 PM 264-7881

**STRATHMORE VILLAGE** - Troy, luxurious condo decorated in soft neutral tones 2 bedrooms, 1 1/2 baths, fireplace living room, full finished rec room with bar, closets everywhere!

**SOMERSET REAL ESTATE**  
649-6800

**TENNIS ANYONE?**  
Or Swim As You Prefer  
Two fine condos at Northfield Hills, now for your approval. Both 2 bedrooms, tastefully appointed in neutral tones. Central air and fireplace (a place for all seasons) terms. Ask for Jerry or Shirley Gottfalle  
**REAL ESTATE ONE**  
528-1300 or 644-1575

**NOVI**  
Interested in leisure living with a touch of country? Then this delightful 2 bedroom townhouse with attached garage is waiting just for you, \$49,500. 478-9130

**Rymal Symes**

**322 Condominiums For Sale**

**NOVI HIGHLAND LAKES**  
Waterfront 3 bedroom, 1 1/2 bath condo with basement, fireplace, central air and more for \$67,900 LAND CONTRACT TERMS

**CENTURY 21 CORNERSTONE 478-4660**

**THE WOODS CONDO, Livonia** 1 bedroom, 1 bath upper. Furnished or unfurnished. Utility room, washer and dryer. Many extras 454-3015 or 591-2199

**TROY East Unit, 2 bedroom Ranch, immaculate. Immediate Occupancy. Assumable 7 1/2 %**, all appliances, fireplace, sq ft, full basement. Open 641-9439 5PM.

**WATLIES CREEK - Troy Deluxe 2 bedroom, 1 1/2 baths, professionally finished basement with wet bar, double carport, decorator drapes, carpeting, all appliances included. \$67,900. Land contract terms. Call Owner Days, 557-2268, or evenings 335-8630 5PM.**

**WESTLAND - Woodview Condo. Low price, must move. \$42,900. Lower on pond, 2 bedroom, 2 bath, Micro dishwasher, references. Days 226-3476, 522-5206**

**W. BLOOMFIELD, Cluster On The Lakes**, condo, spacious 3 bedroom, 3 bath, end unit ranch equipped for comfortable living. Carpeting, drapes, all appliances, and many extras. 851-8982

**W. BLOOMFIELD**, see lot 66, 2 1/2 bedrooms, walk to shopping and transportation from upper level 2 bedroom, 2 bath ranch. No common walls. Extra large rooms, excellent construction, pool, other extras after 7 PM. 851-1828

**W. BLOOMFIELD** Prestigious Pebble Creek Condo. Open bright, Contemporary floor plan in this outstanding 3 bedroom, living room, dining room, 2 baths, central air. Owner leaving for Florida. See and Buy! \$139,500

**325 Washtenaw County**

**INVESTMENT OPPORTUNITY**, Estate sale. Prime Ann Arbor/Ypsilanti area 12 1/2 acre dividable, nice 2 bed room farm house. Large storage building, \$115,000. 861-0483

**326 Duplexes For Sale**

**BIRMINGHAM**  
SHARP 5-5 Brick Flat, two bedrooms each, remodeled kitchen & bath, 1000 sq ft each unit with screened terraces, 2 car, full basement, 2 energy saver gas furnaces.

- SHARP 5-5 BRICK DUPLEX  
**OWNER-BROKER 642-4500**

**CANTON**  
New Colonial duplex. Fantastic tax shelter, 75% annual return, 3 bedrooms, 1 1/2 baths, 1400 sq ft in each unit, 8 approved sites available.

**Lapin Builders, Inc.**  
1-981-1145 Eves. 553-4468

**332 Mobile Homes For Sale**

AS LOW AS  
**\$8,500**  
ON LOCATION  
**WE BUY USED HOMES & TAKE TRADE-INS**

**DARLING Manufactured Homes NOVI** 349-1047  
Novi Rd. - 1/2 Mile S. of I-96  
CLOSED SUNDAYS  
CASH REBATE on stock models  
SAVE UP TO \$1,000  
WONDERLAND  
**MOBILE HOME SALES**  
45475 Michigan Ave 397-2330

Has over 250 mobile homes priced from \$5,000, all set up in park! Singlewides, doublewides and expandos - many for immediate occupancy. Best financing available with low down payment plus 1 year limited warranty with most homes.

**328 Townhouses For Sale**  
COOP TOWNHOUSES 1, 2, and 3 bed rooms available. Monthly charges in-clude, gas for heating, cooking and hot water, plus maintenance. Member-ship sold on cash basis only. 349-5570

**330 Apts. For Sale**  
BY OWNER - well equipped restaurant with Class C Liquor License, seats 150, just over 1 yr old, large parking lot, excellent location on I-75, Gaylord exit 279. Great investment, good tax savings in mind. Available with or without real estate. Excellent growth area. Write PO Box 287, Gaylord, MI. 49735

**PRISONER?**  
Are you laced off? Chained to a dead "Machine"? Do bells ring? In a dead-end job? Putting all your eggs in your employer's basket? Lack opportunity, independence and freedom? Buy your own insurance policy!

Royal Oak, finest location, 5 unit, \$129,000, brick, separate furnaces, appliances, long term tenants, 6-7 years Owner will finance.

Plymouth luxury townhouses, 4 units, 2-3 bedrooms, brick, basement, balcony, 1100 sq ft, \$180,000, terms.

10 unit motel, plus 3 bedroom brick home, \$149,000. Owner will finance. Excellent profit.

**ARE YOU TOO FAT? STOP BEING A PRISONER BUY YOUR OWN INSURANCE POLICY! PERRY 478-7640**

**332 Mobile Homes For Sale**  
**AFFORDABLE HOMES Your Choice Of**

PRICE QUALITY LOCATION  
SUBURBAN MOBILE HOMES

**NOVI 348-1913 HIGHLAND 887-8324**  
AMHURST 1979, 2 bedrooms, 1 1/2 baths, good condition. Can stay on lot in Northville. S. Lyon area. \$14,900. 437-5584 or 476-2053

**336 Florida Property For Sale**

**EAST COAST**, 8 miles N. of Palm Beach, 20 min from airport, 2 bed room, 2 1/2 bath Townhouse \$69,500  
TWO (2) bedroom, 2 bath Garden party furnished on Golf Course, \$96,500  
TWO (2) bedroom, 2 bath Garden on Lakeboat River, furnished \$123,000  
BY OWNER, 879-1164 or 1-797-5282

**INVEST IN BOCA RATON**  
Beautiful Condo overlooking canal with ocean access. Large master bedroom suite, also guest lav off foyer. Across from posh Royal Palm Yacht Club. Minutes away from over 50 fine Golf Courses. Assumable mortgage. Really listing expired. Owner reduced to sell fast, \$66,000. 882-9886

**LEHIGH FLA** property, about 1 acre, \$200,189  
280-1889

**PUNTA GORDA** deep creek section, valuable for trade up to 11 acres, \$13,500. 291-6804

**ST. PETERSBURG AREA**  
Inla Del Sol By owner new 2 bedroom waterfront villa condo. Selling for \$97,900, sacrifice \$92,900. Rebate for plane fare if purchased. 661-2060

**VERO BEACH** - New 3 bedroom ranch, 2 baths, 2 car garage, 700 Ft. from the ocean. Energy efficient with central air. \$106,000. 682-8892

**338 Lots & Acreage For Sale**

**LAKES OF NORTHVILLE WOODED LOTS**  
All improvements in 100-1320 \$49,900  
626-4050 MARK

**LAPEER LAND BUYS**  
METAMORA AREA - Unique 2 acre parcels, rolling, and wooded. \$10,900 each. L.C. terms Call 1-678-2284

**IMLAY AREA**, 10 acres on a blacktop road, good frontage. Area a great buy at \$12,900. L.C. terms Call 1-798-8591

**DRYDEN** - 8 acres with a large pond. Good area. \$15,900. L.C. terms Call 1-678-2284

**5-ACRE SPECIAL** - Nice rolling parcel. Lapeer area. \$9,900. Call 1-684-1892

**33 WOODED ACRES** - Blacktop road, great for firewood, can be split. Lapeer area. \$16,900. L.C. terms Call 1-636-2284

**BORDERS STATE LAND** - 10 acres, 1/4 wooded, blacktop road frontage. Lapeer area. \$16,000. L.C. terms Call 1-678-8591

**THORNVILLE**, Metamora Hunt area 10 acres, rolling, partially wooded. Clean river frontage. \$23,000. L.C. terms Call 1-678-8591

**GARDNER & ASSOCIATES**  
Metamora - Almont  
Goodrich - Lapeer

**LOTS FOR LUXURY HOMES**  
Limited number of large home sites. Released & available for luxury homes in the recently developed, controlled & established subdivision of Meadowbrook Forest in Farmington Hills. Some very choice wooded lots. All facilities. Build now or buy on land contract with very easy terms & build later with builder of your choice. Custom builders welcome. By owner 476-0519

**LOTS FOR SALE**  
West Bloomfield all utilities ready to build wooded. 661-5987  
626-2355

**MARLETTE**, 7 miles west, 190 acres. Excellent property for hunt club, family campground or executive farming. Wooded, creek, pasture, flat land on blacktop \$400 per acre. Cash, no loan. 313-363-6431

**NOVI BY OWNER**  
50 Acres. Beautiful rolling land. 1 mile from Maybury State Park. 1 Mile from I-96. 961-2362

**OVER 1 1/2 ACRES**  
In city of Bloomfield Hills, including all utilities, in subdivision with terms of \$150,000 plus homes. Close to Bloomfield Open Hunt Club. Asking \$59,900

**CRANBROOK ASSOC. INC., REALTORS**  
645-5790

**PLYMOUTH TWP.**  
3 large residential lots. Ann Arbor. Trail. All utilities, terms good building. 459-3396

**PONT AUSTIN**, 40 wooded acres local, \$150,000. City stream through property. Contact Sharon Horny, Associate, H. I. Dykes Real Estate (Caseville) Phone 517-856-3400 or 800-292-3636

**PRIME WOODED 23 ACRES**  
West Bloomfield for Zoned cluster. Sell or need another investor.  
332-3230

**REDFORD TWP.** 8 Mile & Grand River area. Residential lot, paved street. 20067 Pinesiana \$5500 with terms. 3-157-468-3462

**RESIDENTIAL lot S. of Rochester** all utilities, \$10,000. Can arrange terms. Eves 752-7583

**322 Condominiums For Sale**

**CLOSE-OUT!**  
at Country Glens  
- 76 units sold -  
A few choice units left.

1-Bedroom, 1-Bath  
Condominium Homes  
priced from \$45,900.  
2-Bedroom, 2-Bath  
priced from \$64,900.

**Country Glens**  
FARMINGTON HILLS  
SAT. SUN. MON.-TUES. 1-7  
(by appointment)  
626-8450 or 626-8452  
(no answer, 1-662-3282)

GARNET JOHNSON & ASSOCIATES, LTD.  
THOMAS, POMEROY REALTY, INC.

**322 Condominiums For Sale**

**Walnut Grove Villas**  
CONDOMINIUMS  
From \$97,990.

Some for Early Occupancy

Featuring 1 & 2 story condominiums with (2) car attached garage. Full basement. 2 & 2 1/2 baths. Fireplace. Central air. Appliances. First floor laundry room plus many more custom features!

**Model open Noon-7 p.m. Daily & Sun. Noon-5 p.m. Sat. Closed Thurs.**

**SCHRAM REALTY**  
Model 357-2190  
Office 851-3800

**322 Condominiums For Sale**

**Century 21**  
FAIR TOWNE CO.  
626-8000

20 min to Renaissance Center  
Semi- or dry Terrace  
1711 E Jefferson, Grand Pointe. Deluxe 1st floor condominium 6 rooms. Full security. Monthly maintenance fee. \$29. For sale only. \$170,000.

**DETROIT BANK & TRUST**  
Trust Real Estate 962-7656

**323 Livingston County**  
BEST BUYING OPPORTUNITIES  
may be the best that will ever be.

**EAGLE HEIGHTS OF BRIGHTON**  
1 mile N of I-96  
on Pleasant Valley Rd.  
Homes priced from \$108,500.

**West Hartland Wds.**  
1.95 to US23, N. East M 59  
1 1/2 mile, turn left  
Homes priced from \$85,500

**ADLER HOMES INC.**  
Office 632-6222 Model 229-2692  
Models open 7 days, 11-6  
LAND CONTRACT TERMS  
Wide open country style lots

**325 Washtenaw County**

**EAST TOWN TERRITORIAL RD.**  
Almost 2 acres. Four large bedrooms, 2 1/2 bath, family room, loads of closet space. 24 x 24 garage. Custom built 1968. Large outdoor with approximately 30 chickens. tractor available. L.C. Terms or 8 1/2 assumption available. Asking \$71,900

**GARLING INC**  
453-4800 562-6144

**322 Condominiums For Sale**

**CAREFREE LIVING**  
in this FIRST FLOOR KNIGHTSBRIDGE CONDOMINIUM. 2 Big bedrooms Plus library and "get-away" office. 2 1/2 baths, storage room, large and fully enclosed patio, direct-access 2 car garage. YOUR ANSWER? \$138,500.

**FOUR SEASONS**  
Condominium home in Bloomfield Hills. Two unusually large bedrooms, 2 sparkling tiled baths, utility room in unit, enclosed parking with automatic door opener and covered balcony with a park-like view. TOP LOCATION AND VALUE! \$98,500.

**WEST BLOOMFIELD**  
If you want one floor convenience, this 2 bedroom, 2 bath condo may be for you. The laundry is only steps from the bedrooms. Priced at \$83,900. Call for details and features.

**CONDO-MART**  
has over half a Decade of Condominium Sales Service Experience. We cut our teeth in this field before others dared to enter.  
Rely on a Leader,  
Rely on Condo-Mart.

**C-M CONDO-MART REALTORS, INC.**  
626-8100

**332 Mobile Homes For Sale**

**LITTLE VALLEY**  
MOBILE HOMES  
476-4072

FREE COLOR TV'S  
with the purchase of new homes

**NEW CENTURION**, 60 x 14, with dishwasher \$12,690  
**NEW PATRIOT**, 70 x 14, 3 bedrooms \$13,990  
**NEW BAYVIEW** deluxe, 60 x 12, \$12,990  
**CAMBRIDGE** 70 x 14 plus 14 x 7 expando, on large lot in Hamburg. NOW only \$14,990  
**PARK ESTATE** 60 x 12 - on location in Southfield, stove, refrigerator, carpet. \$11,990  
**CAMP DEARBORN SEPTALS**  
AS LOW AS \$3,890  
**RICHARDSON** 60 x 12, \$5,490  
**MONARCH** 60 x 12, \$5,990  
**CAMBRIDGE** 65 x 12, \$6,490  
**PARK ESTATE** 60 x 12, \$6,490  
**ACTIVE** 60 x 12, \$6,490  
**MONARCH** 60 x 12, \$6,990

**LITTLE VALLEY**  
MOBILE HOMES  
476-4072

**MOBILE HOMES WANTED**  
Qualified Buyers  
QUICK RESULTS  
Free In-Home Appraisal

**global**  
Mobile Homes  
352-5775

MOBILE HOME 12 x 60, 2 bedrooms, remodeled interior, large lot, deck & patio. Financing available. 685-3279  
**PATRIOT 1977**, Executive, 3 bedroom, 1 1/2 bath, 14x70, shed, deck, landscaped yard, can stay on lot. Old Dutch Farms, Novi \$16,500 349-1860  
**PEERLESS** 12 ft x 60 ft, 2 bedroom, stove, refrigerator, alum. wiring, porch, completely skirted, excellent \$13,000. 464-9884 or 425-8562  
**RITZCRAFT 1974**, 12x60, 2 bedroom, 1 1/2 bath, unfurnished, shed, Ypsilanti, can stay on lot, \$7000 or best offer (call before 2 pm weekdays) 465-3772  
**SHERWOOD PARK**, 1978, 14x70, by owner, 2 bedroom, 1 bath, island kitchen, all appliances & drapes. Shed with fenced patio. In Canton. Mint condition \$15,500. 851-5355  
**SHULT** 1974 Mobile Home, central air, 3 bedrooms, located at Holiday West, Willis Road, Belleville. \$99,217 or 455-1110  
**STERLING** 1970, 12x63 2 bedroom, shed, skirting, carpeted, furnished. Can stay on lot. Novi \$8700 or offer. 348-9582

**336 Florida Property For Sale**

**BRIGHTON**  
10 acres stream, paved road, 1 mile off I-96. \$32,900

**HARTLAND**  
10 acres, wooded, stream, paved road, natural gas. E off US23 and M-59 \$20,500  
10 acres, wooded, high & dry, paved road, natural gas. W off US23 & M-59 \$38,500  
5 acres, beautiful building site, natural gas \$21,200. Land Contract terms available  
**TOM ADLER REALTY** 313-623-6222

**BUILD among the pines 2001 1500H** secluded, acreage. Hillside walk-out, four bedroom, natural gas, full basement, 2 car garage. 2400 sq ft. Call Contract or Cash. Orion Twp. 693-1651

**CITY OF Bloomfield Hills 2 acre wooded ravine lot in Trowbridge Farms Colquhoun Realtors.** 646-1650  
453-4128

**CITY OF Bloomfield Hills**  
1 1/2 acres, wooded, secluded, out developed country setting. L.C. available. N of 13 Mile, W of Orchard Lake Rd. Area of \$350,000. Home all utilities, excellent soil borings, ready for building. \$44,500. Land Contract or discount for cash.  
855-9850

**338 Lots & Acreage For Sale**

**BRIGHTON**  
10 acres stream, paved road, 1 mile off I-96. \$32,900

**HARTLAND**  
10 acres, wooded, stream, paved road, natural gas. E off US23 and M-59 \$20,500  
10 acres, wooded, high & dry, paved road, natural gas. W off US23 & M-59 \$38,500  
5 acres, beautiful building site, natural gas \$21,200. Land Contract terms available  
**TOM ADLER REALTY** 313-623-6222

**BUILD among the pines 2001 1500H** secluded, acreage. Hillside walk-out, four bedroom, natural gas, full basement, 2 car garage. 2400 sq ft. Call Contract or Cash. Orion Twp. 693-1651

**CITY OF Bloomfield Hills 2 acre wooded ravine lot in Trowbridge Farms Colquhoun Realtors.** 646-1650  
453-4128

**CITY OF Bloomfield Hills**  
1 1/2 acres, wooded, secluded, out developed country setting. L.C. available. N of 13 Mile, W of Orchard Lake Rd. Area of \$350,000. Home all utilities, excellent soil borings, ready for building. \$44,500. Land Contract or discount for cash.  
855-9850

**"City of Bloomfield Hills"** (CHARMING CRISS WOODS OF BLOOMFIELD)  
New development, large choice lot available with all improvements. Creative financing available. Leading custom builders can help solve your building problems. Select a lot today & build your DREAM HOME tomorrow.

**CHESNUT HILLS**  
choice building of Bloomfield & Echo Ridge Subdivision. Just north of the prestigious Bloomfield Hills Country Club.

**Spectrum group, inc.**  
642-9020

**CLARKSTON** area, several choice building sites, from \$15,000. Sylvan. 394-0300

**CUSTOM HOMES**  
Your lot or ours. Your plan or ours.  
F. L. Roberts Building Co. Plymouth 453-4128

**FARMINGTON HILLS** 1/4 acre prime location, country setting, L.C. available. N of 13 Mile, W of Orchard Lake Rd. on Greenboro. \$24,900. Offer Evenings. 851-9534, Days. 478-7222

**FARMINGTON HILLS** Builders fully improved lots in prestigious subdivision. Prime location, build and contract terms. From \$28,500 474-9300 or 477-1070

**FARMINGTON HILLS**  
Trestain Ave., 100 X 260 ft. lot, S. of 11 Mile, W. of Orchard Lake Rd. New sewer, land contract terms.  
**CALL LARRY LINN MAYFAIR 522-8000**  
Hamburg - Pinckney area 3 & 10 acre parcels. Ready to build. Land Contract. Paved road, gas, south facing hill, trees. Call 9am - 5pm 453-4128

**HAMBURG Pinckney Area**  
Vacant Land for Home Building  
453-4145  
9AM - 5PM

**IRISH HILLS** 1 1/2 acres with beautiful view of lake. Beautiful building site. Ideal for retirement, etc. \$7,900. Cash or Land Contract terms. 981-8189

**NORTHVILLE**  
Ravine and heavily treed lot. Situated in the City of Northville, all utilities, walking distance to town and church. Land contract terms. Priced at \$30,000.  
**JAMES C. CUTLER REALTY** 349-4030

**CANAL FRONTAGE ON PORTAGE LAKE**  
Huge lot, motors allowed. Land contract terms \$26,000.  
**JAMES C. CUTLER REALTY** 349-4030

**HORSESHOE LAKE (Private)**  
6 Mile Rd. - US 23 area. 2 rest. Blot. over looking lake. Sewer, private beach, power, boating 100. Children's school bus. Both \$15,900. Call Walter Frisch. 851-6004

**DURBIN**  
COMPANY REALTORS  
Your Neighborhood Broker

INTERESTED IN A Prime Lake Lot on which to build your Dream Home? We have lots on Lakes W. Bloomfield area Oakland County. Can be bought on terms. Above average in Quality and price.  
**HOWLAND ALDER REALTY, INC**  
553-3600

**NORTHCREST CONDOMINIUMS**

Beautifully located near scenic Green's Lake.

Northcrest Village combines the very best of condominium living with the beauties of nature — for the best of both worlds. You can get all the convenience, liveability and economy of a condominium home — and the ecologically planned Village includes extensive protected nature areas with a permanently dedicated Wildlife Sanctuary. Northcrest Village is near gorgeous Green's Lake where you'll enjoy Fishing, Swimming, Sailing, Boating — or just plain relaxing.

**PRICED FROM \$58,900**

**10 1/2 % INTEREST 20% DOWN 30 YEAR MORTGAGES**

**CAMBRIDGE REALTY NORTHCREST VILLAGE**  
On Dixie Highway between White Lake and Ortonville Road  
CLARKSTON, MICHIGAN Phone: 625-9434 Open: 12 a.m. to 6 p.m.

**PROVIDENCE TOWERS**

**All New Luxury Highrise Condo**

- Ideally located in Southfield
- Elegant lobby with doorman
- Doorwall & Balcony off every room
- 2000 Sq. Ft. - 2 Bedroom
- 2500 Sq. Ft. - 3 Bedroom
- Underground Parking
- Clubroom • Pool
- Spa • Tennis
- Plus many more custom features!

Open Daily & Sunday:  
Noon - 7PM  
Saturday: Noon - 5PM

**Model Phone: 557-8775**  
Office Phone: 851-3800  
**IMMEDIATE OCCUPANCY**  
**SCHRAM REALTY**  
Priced from \$82,000

**global**  
MOBILE HOMES  
476-4072

**WANTED**  
Qualified Buyers  
QUICK RESULTS  
Free In-Home Appraisal

**global**  
Mobile Homes  
352-5775

MOBILE HOME 12 x 60, 2 bedrooms, remodeled interior, large lot, deck & patio. Financing available. 685-3279  
**PATRIOT 1977**, Executive, 3 bedroom, 1 1/2 bath, 14x70, shed, deck, landscaped yard, can stay on lot. Old Dutch Farms, Novi \$16,500 349-1860  
**PEERLESS** 12 ft x 60 ft, 2 bedroom, stove, refrigerator, alum. wiring, porch, completely skirted, excellent \$13,000. 464-9884 or 425-8562  
**RITZCRAFT 1974**, 12x60, 2 bedroom, 1 1/2 bath, unfurnished, shed, Ypsilanti, can stay on lot, \$7000 or best offer (call before 2 pm weekdays) 465-3772  
**SHERWOOD PARK**, 1978, 14x70, by owner, 2 bedroom, 1 bath, island kitchen, all appliances & drapes. Shed with fenced patio. In Canton. Mint condition \$15,500. 851-5355  
**SHULT** 1974 Mobile Home, central air, 3 bedrooms, located at Holiday West, Willis Road, Belleville. \$99,217 or 455-1110  
**STERLING** 1970, 12x63 2 bedroom, shed, skirting, carpeted, furnished. Can stay on lot. Novi \$8700 or offer. 348-9582

**TOP OF THE LIVE** Beautiful brand new 1980 Parkwood. Occupied only 9 months. 14 X 70. 2 bedrooms, 2 full baths, corner fireplace. 349-2322

**334 Out Of Town Property For Sale**  
**HILTON HEAD ISLAND**, So Carolina. Choice wooded lot on Dolphin Head Golf Course. One block from beach. \$54,000 negotiable. 646-8746

**WELCOME ROCKWELL TO Henderson County, N.C.**  
For free information on your new area contact  
**Hatheway Realty, Inc.**  
1610 Four Seasons Blvd., Hendersonville, N.C. 28739 (704) 697-1471

**334 Out Of Town Property For Sale**  
**UNBELIEVABLE CHARM**

**TROY LOTS**  
Treed, rolling acreage  
Custom homes up to \$250,000  
1 1/2 acre & larger  
Homeowner & Investor Welcome!  
L.C. TERMS  
1-8PM  
879-7778

**TWO choice 1 acre lots available** in Plymouth Twp. Walk across the street to park and golf course. Perker gas available. Negotiable down payment. Land contract terms. 459-6542

**Unbelievable Terms**  
On this site in desirable West Bloomfield with privileges on Upper Straits Lake in area of new homes. \$24,900  
Max  
**BROOK**  
626-4000

**WABEEK LAKE ACCESS LOTS**  
New choice lots in Bloomfield area. View and privacy left at the exclusive Wabek Manor Sub. Bloomfield Hills schools. For information call  
649-3761

**W. BLOOMFIELD**  
Lot 130-1144  
Sewer in. Land Contract terms  
Call 682-1522

**10 ACRES - Pontiac Trail** Frontage \$3,800 per acre. 44 wooded acres. 1/4 acre lot. Only 3 miles to Wixom. 1.96 Ext. 6 miles to Twelve Oaks Mall. DRS Realty. 363-6111

**26 ACRES**  
ripe for development. Water & sewer at property line. City of South Lyon. \$165,000. 1-437-6981

**340 Lake-River-Resort Property For Sale**  
**LAKE LOT**, approximately 100 ft. x 300 ft. on Tan Lake in Orford Twp. All sports lake, lot is suitable for walk out basement.  
**BUY YOUR BUILDING SITE & BECOME** a part owner of Michaywre Resort near Gaylord approx. 100x190 lot on Oakland Hills Rd. \$9500. A sports social, sewer & serene environment, low taxes & much more. 573-0528

**\$58,900**

**10 1/2 % INTEREST 20% DOWN 30 YEAR MORTGAGES**

**CAMBRIDGE REALTY NORTHCREST VILLAGE**  
On Dixie Highway between White Lake and Ortonville Road  
CLARKSTON, MICHIGAN Phone: 625-9434 Open: 12 a.m. to 6 p.m.

**PROVIDENCE TOWERS**

**All New Luxury Highrise Condo**

- Ideally located in Southfield
- Elegant lobby with doorman
- Doorwall & Balcony off every room
- 2000 Sq. Ft. - 2 Bedroom
- 2500 Sq. Ft. - 3 Bedroom
- Underground Parking
- Clubroom • Pool
- Spa • Tennis
- Plus many more custom features!

Open Daily & Sunday:  
Noon - 7PM  
Saturday: Noon - 5PM

**Model Phone: 557-8775**  
Office Phone: 851-3800  
**IMMEDIATE OCCUPANCY**  
**SCHRAM REALTY**  
Priced from \$82,000

**global**  
MOBILE HOMES  
476-4072

**WANTED**  
Qualified Buyers  
QUICK RESULTS  
Free In-Home Appraisal

**global**

CLASSIFIED REAL ESTATE

340 Lake-River-Resort Property For Sale

ALPINE RESORT A perfect tax shelter & investment. The resort on Wallon Lake on 24 acres...

342 Lakefront Property

OPEN SUN 2-5 PM 2752 North Lake Dr. Located in beautiful Lake Angelus Golf View Estate...

342 Lakefront Property

CECILIA 3 bedroom year round home, large walkout basement, fireplace, extra nice wooded lot...

342 Lakefront Property

CEDAR ISLAND LAKEFRONT Spectacular 3 bedroom Contemporary, vaulted ceilings, premium kitchen...

342 Lakefront Property

CLARE, MICH. Beautiful Five Lakes, lovely 1 to 4 bedroom homes. Several styles, elegant or rustic...

342 Lakefront Property

CLARKSTON LAKEFRONT Just North of the Village 13 to choose from sewer & water 1800 Hargreaves & Blarnek...

342 Lakefront Property

COMMERCE LAKE, 2 year old Tudor Ranch, 300 ft. frontage, 3 bedrooms, 2 1/2 baths...

342 Lakefront Property

COMMERCIAL LAKE 2 bedroom 2 1/2 bath, dual fireplaces, wood trim, shutters on windows...

342 Lakefront Property

COXLEY LAKE Perked and natural grade for walkout basement. All sports lake, oak trees...

342 Lakefront Property

DEER LAKE CLARKSTON Wood stone & glass contemporary on spacious rolling wooded lot...

344 Country Homes

ORTONVILLE AREA COUNTRY HOMES CHOOSE FROM THESE LAKEFRONT OR LAKE PRIVILEGE HOMES...

344 Country Homes

ORLANDO LAKE Beautiful area of fine homes on 1/2 acre treed lot with water frontage...

344 Country Homes

ORCHARD LAKE FINE HOME 12 acres Beautiful sunsets from windward side of lake...

344 Country Homes

PANORAMIC VIEW OF LAKE 100 Ft. of lake frontage Sandy beach, boat launch, 40 ft. of dock...

344 Country Homes

PINE LAKE FRONT \$20,000 DOWN will buy charming 2-story home with sloping lawn...

344 Country Homes

PRICED REDUCED TO SELL Get away to the lake all year long in this open, bright, all brick walkout ranch...

344 Country Homes

PRIME LAKE property on Green Lake in West Bloomfield. Chalet style, 8 years old...

344 Country Homes

SHARP 1 BEDROOM HOME On tree shaded acre in Webster Twp., 4 car garage...

344 Country Homes

SHARP COMMERCIAL BUILDING Well appointed 3000 sq. ft. building for sale. Suitable for dental, medical or any general office use...

344 Country Homes

SHARP COMMERCIAL BUILDING Well appointed 3000 sq. ft. building for sale. Suitable for dental, medical or any general office use...

344 Country Homes

SOMERSET REAL ESTATE Beautiful area of fine homes on 1/2 acre treed lot with water frontage...

344 Country Homes

WOODS RETREAT 3 bedrooms, large living room, dining room, kitchen with appliances...

344 Country Homes

WALNUT LAKEFRONT Magnificent TOWERING trees set off this bungalow with lake privileges...

344 Country Homes

WALNUT LAKEFRONT Magnificent TOWERING trees set off this bungalow with lake privileges...

344 Country Homes

WALNUT LAKEFRONT Magnificent TOWERING trees set off this bungalow with lake privileges...

344 Country Homes

WALNUT LAKEFRONT Magnificent TOWERING trees set off this bungalow with lake privileges...

344 Country Homes

WALNUT LAKEFRONT Magnificent TOWERING trees set off this bungalow with lake privileges...

344 Country Homes

WALNUT LAKEFRONT Magnificent TOWERING trees set off this bungalow with lake privileges...

344 Country Homes

WALNUT LAKEFRONT Magnificent TOWERING trees set off this bungalow with lake privileges...

344 Country Homes

WALNUT LAKEFRONT Magnificent TOWERING trees set off this bungalow with lake privileges...

344 Country Homes

WALNUT LAKEFRONT Magnificent TOWERING trees set off this bungalow with lake privileges...

344 Country Homes

WALNUT LAKEFRONT Magnificent TOWERING trees set off this bungalow with lake privileges...

348 Cemetery Lots

CADILLAC MEMORIAL GARDENS 4 grave plot, Rugged Cross Section, \$900...

348 Cemetery Lots

FOUR CEMETARY PLOTS Parkview Memorial Association \$300 each or \$1100 complete...

348 Cemetery Lots

OAKLAND HILLS, Novi, 4 lots, Apostle Section, \$500 Worth \$260 each...

348 Cemetery Lots

WHITE CHAPEL 4 lots, \$425 each, Evenings 444-8803

348 Cemetery Lots

LIVONIA MINI FARM 1 1/2 acres 3 bedroom home, pool, horse barn...

351 Bus & Professional Bldgs. For Sale

BIRMINGHAM 14 MILE PIERCE Commercial lot (110x120) Modern gas station/garage building...

351 Bus & Professional Bldgs. For Sale

BIRMINGHAM 14 MILE PIERCE Commercial lot (110x120) Modern gas station/garage building...

351 Bus & Professional Bldgs. For Sale

DINSMORE REALTY SHARP Commercial Building, 14 Mile & Woodward area...

351 Bus & Professional Bldgs. For Sale

INDUSTRIAL PROPERTY COMMERCIAL land 1/4 acre and country market on Amber Rd. W. of Plymouth...

351 Bus & Professional Bldgs. For Sale

INCOME PROPERTY BIRMINGHAM 3 Family apartment building...

351 Bus & Professional Bldgs. For Sale

INVESTMENT PROPERTY NEW REAL ESTATE INVESTORS' How to get into the real estate investment business...

362 Real Estate Wanted

ABSOLUTELY TOP CASH FOR PROPERTY Regardless of Condition Even If Behind In Payments All Suburban Areas

362 Real Estate Wanted

CASH TODAY OR GUARANTEED SALE Also In Foreclosure Or Need Repair

362 Real Estate Wanted

CASTELLI 525-7400 NO LISTINGS WE JUST PAY CASH

362 Real Estate Wanted

CASTELLI 525-7400 NO LISTINGS WE JUST PAY CASH

362 Real Estate Wanted

CASTELLI 525-7400 NO LISTINGS WE JUST PAY CASH

362 Real Estate Wanted

CASTELLI 525-7400 NO LISTINGS WE JUST PAY CASH

362 Real Estate Wanted

CASTELLI 525-7400 NO LISTINGS WE JUST PAY CASH

362 Real Estate Wanted

CASTELLI 525-7400 NO LISTINGS WE JUST PAY CASH

362 Real Estate Wanted

CASTELLI 525-7400 NO LISTINGS WE JUST PAY CASH

362 Real Estate Wanted

CASTELLI 525-7400 NO LISTINGS WE JUST PAY CASH

362 Real Estate Wanted

CASTELLI 525-7400 NO LISTINGS WE JUST PAY CASH

368 Real Estate To Exchange

1031 EXCHANGOR Property Equities Wanted Michael J. Caffery, Realtor Assoc.

368 Real Estate To Exchange

ABANDON YOUR HUNT Select Rentals We Help Landlords & Tenants Share Listings

368 Real Estate To Exchange

A FRESHLY decorated 1 bedroom apt carpeted, \$300 to \$310 per mo. Heat included...

368 Real Estate To Exchange

APPLICATIONS now being accepted for one bedroom apartments Write Bill & Helen White 2320 Fenkel, apt 106...

368 Real Estate To Exchange

ATTRACTIVE Quiver At Palmer Park area Quiet & well maintained building located next to Palmer Park...

368 Real Estate To Exchange

BIRMINGHAM MANOR 900 N Adams Available 2 bedroom & den apartment...

368 Real Estate To Exchange

BIRMINGHAM 2 APTS AVAILABLE 2 bedroom apartment, air fully carpeted...

368 Real Estate To Exchange

BIRMINGHAM 2 APTS AVAILABLE 2 bedroom apartment, air fully carpeted...

368 Real Estate To Exchange

BIRMINGHAM 2 APTS AVAILABLE 2 bedroom apartment, air fully carpeted...

368 Real Estate To Exchange

BIRMINGHAM 2 APTS AVAILABLE 2 bedroom apartment, air fully carpeted...

368 Real Estate To Exchange

BIRMINGHAM 2 APTS AVAILABLE 2 bedroom apartment, air fully carpeted...

400 Apartments For Rent

AVAILABLE AUG 1-2 bedrooms, Royal Oak 13 Mile & Woodward Area Close to Shopping...

400 Apartments For Rent

AVAILABLE IMMEDIATELY Well decorated one & two bedroom apartments...

400 Apartments For Rent

1ST MONTHS RENT FREE HAMPTON HOUSE APTS. LARGE 2 Bedroom Apartments \$330 per month...

400 Apartments For Rent

WELL Maintained Close to Shopping, 1 Block North of Maple, 1 Block E. of Coolidge, near Somerset Mall

400 Apartments For Rent

LOOK FOR THE Apartment with the Canopy FOR APPOINTMENT Contact Manager Bonnie Miller

400 Apartments For Rent

BIRMINGHAM 2 bedroom, 1 1/2 bath, air conditioning, industrial washer & dryer...

400 Apartments For Rent

BIRMINGHAM 2 bedroom, 1 1/2 bath, air conditioning, industrial washer & dryer...

400 Apartments For Rent

BIRMINGHAM 2 bedroom, 1 1/2 bath, air conditioning, industrial washer & dryer...

400 Apartments For Rent

BIRMINGHAM 2 bedroom, 1 1/2 bath, air conditioning, industrial washer & dryer...

400 Apartments For Rent

BIRMINGHAM 2 bedroom, 1 1/2 bath, air conditioning, industrial washer & dryer...

400 Apartments For Rent

BIRMINGHAM 2 bedroom, 1 1/2 bath, air conditioning, industrial washer & dryer...

400 Apartments For Rent

BIRMINGHAM PROPER 2 APTS AVAILABLE 2 bedroom apartment, air fully carpeted...

400 Apartments For Rent

BIRMINGHAM 14 Mile & Pierce 1 1/2 bedroom Apts \$330 and \$380

400 Apartments For Rent

BIRMINGHAM 2 bedroom, 1 1/2 bath, air conditioning, industrial washer & dryer...

400 Apartments For Rent

BIRMINGHAM 2 bedroom, 1 1/2 bath, air conditioning, industrial washer & dryer...

400 Apartments For Rent

BIRMINGHAM 2 bedroom, 1 1/2 bath, air conditioning, industrial washer & dryer...

400 Apartments For Rent

BIRMINGHAM 2 bedroom, 1 1/2 bath, air conditioning, industrial washer & dryer...

400 Apartments For Rent

BIRMINGHAM 2 bedroom, 1 1/2 bath, air conditioning, industrial washer & dryer...

400 Apartments For Rent

BIRMINGHAM 2 bedroom, 1 1/2 bath, air conditioning, industrial washer & dryer...

400 Apartments For Rent

BIRMINGHAM 2 bedroom, 1 1/2 bath, air conditioning, industrial washer & dryer...

400 Apartments For Rent

BIRMINGHAM 2 bedroom, 1 1/2 bath, air conditioning, industrial washer & dryer...

400 Apartments For Rent

BIRMINGHAM 2 bedroom, 1 1/2 bath, air conditioning, industrial washer & dryer...

400 Apartments For Rent

BIRMINGHAM AREA Luxury apartments available 1 bedroom \$476 per month...

400 Apartments For Rent

BIRMINGHAM DOWNTOWN APTS Luxury appliances, plush carpeting and elevators

400 Apartments For Rent

BIRMINGHAM 2 Bedroom Townhouse with full basement in beautiful wooded area...

400 Apartments For Rent

WESTLAND AREA Attractive 1 bedroom apartment \$245 month. Carpeted, decorated air conditioned...

400 Apartments For Rent

BIRMINGHAM Apartment \$225 a month Available August 18. Singles only...

Home Is Where You Drive It...

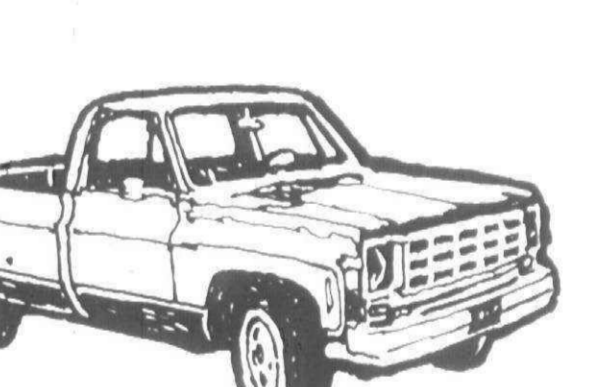
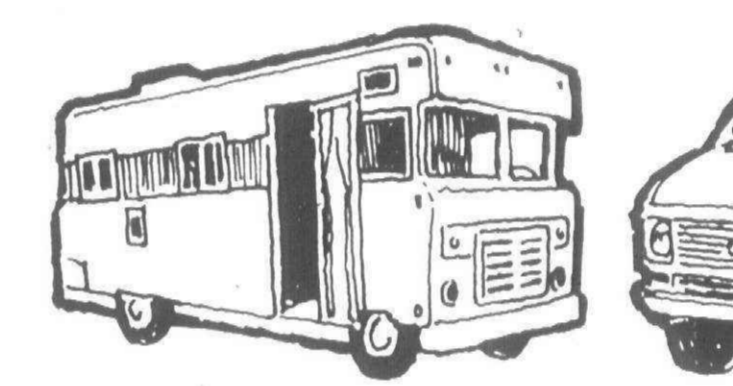
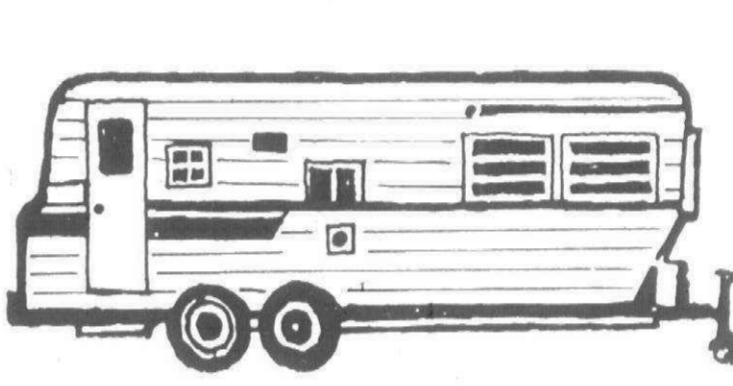

in a Recreational Vehicle you find in our Want Ads

Recreational vehicles designed to fit any budget or level of luxury you desire are offered in today's Want Ads. You'll find modest camper to self-propelled vehicles...

Cranbrook Assoc. Inc. Realtors 853-2200

OPEN SUNDAY 1-5 PM Walled Lake frontage, two (2) Year-round or Summer homes \$34,900 and \$58,900

Cranbrook Assoc. Inc. Realtors 853-2200

OPEN SUNDAY 2-5 ON THE LAKE This spot and spot 3 bedroom Spanish b-level fronts on a small lake and has privileges...

Cranbrook Assoc. Inc. Realtors 853-2200

Go to Middlebelt and Square Lake Road and follow Open Sign to 2115 South Hammond Lake Drive

Cranbrook Assoc. Inc. Realtors 853-2200

Max BROOCK 626-4000

Executive Realtors 476-5990

FOUR BEDROOM remodeled farmhouse. Looks like a Currier & Ives painting...

Executive Realtors 476-5990

HOME GROWN'S THE BEST! 10 room aluminum sided centennial factory home...

Executive Realtors 476-5990

WALNUT LAKEFRONT Charming custom 2 bedroom, plus large dormitory upstairs...

Executive Realtors 476-5990

FOR SALE Modern 3 bedroom waterfront home in private resort with contemporary interiors...

Executive Realtors 476-5990

FOR SALE Beautiful older home on Bluff Drive. Redecorated in a traditional style...

Executive Realtors 476-5990

FOR RENT Victorian Cottage on waterfront in city of Harbor Springs. Furnished...

Executive Realtors 476-5990

MATTHEWS-HEMINGER Real Estate, Inc. 194 East Main Street Harbor Springs, Mi. 49740

Executive Realtors 476-5990

FOR SALE A-FRAME CHALET-100 ft water frontage on private lake...



# CLASSIFIED REAL ESTATE

**400 Apartments For Rent**

**BOTS福德 PLACE**  
GRAND RIVER-8 MILE  
Behind Botsford Hospital  
**PETS PERMITTED**  
**LUXURY LIVING**  
**LOWEST RENT IN FARMINGTON HILLS**  
Smoke Detectors Installed  
Singles Welcome  
Immediate Occupancy  
We Love Children  
**HEAT & WATER INCLUDED**  
**1 BEDROOM for \$309**  
**2 BEDROOM for \$389**  
**3 BEDROOM for \$449**  
Quiet prestige address swimming pool  
air conditioning, carpeting, stove & refrigerator  
all utilities except electricity included  
Warm apts. Laundry facilities  
Intercom system. Good security  
Playground on premises. 2 blocks from school.  
For more information, phone  
**477-8464**  
**27883 Independence**  
Farmington Hills

**BRIARHOUSE APTS**  
12 Bedroom apartments 2400 Par  
menter Royal Oak Spacious carpeted  
pool adults preferred 280-1865

**BRIGHTON** Newly decorated 2 bed  
room apartment Appliances air condi-  
tioning \$235 month plus security  
313-681-5469  
313-681-5923 or

**CANTON** Sublet 1 bedroom Apt Aug  
1st thru Feb. First Month Free \* \$270  
Security Anytime 353-4798 or after  
4pm 453-3209

**CENTURY VILLAGE**  
THE Century To Live In  
1 & 2 Bedroom Apts  
Air Conditioning Pool  
Laundry Hook Ups From \$280  
373-0420

**400 Apartments For Rent**

## RIVER BEND

Luxuriously carpeted 1 and 2 bedroom apartments  
and 2 bedroom 1 1/2 bath townhouses. Dishwasher,  
air conditioning, HOTPOINT appliances, glass  
doorways onto balconies — walk-in closets,  
imposing Community House and swimming pool ex-  
clusively for residents.

Open Daily and Sunday 10 a.m. - 6 p.m.  
Monthly rent includes all utilities except electricity

\* Hudson's Westland 5 minutes away  
\* SEMTA at your doorstep  
\* Expressway accessibility

**RENTAL OFFICE 421-4977**  
**30500 W. Warren**  
Between Middlebelt and Merriman

**1 MONTH'S FREE RENT\***

\*on designated units  
**LAKE POINTE VILLAGE APARTMENTS**  
In Plymouth Township  
• 1 & 2 bedrooms  
• Pool & Club House  
• Air Conditioned  
• Balconies & Patios  
• All Appliances  
• Carpeted  
• Window Shades  
• Plenty of Trees, Grass  
& Open Space

from **\$290**  
14170 SHADYWOOD  
Enter off SCHOOLLCRAFT & WILCOX  
WEST OF HAGGERTY AND  
EAST OF HINES DRIVE  
Close to I-275  
OPEN DAILY 11 to 5 p.m.  
**PHONE 453-1597**  
Jim Smith, Mgr.

**GRAND OPENING**

**In Farmington Hills**  
Be among the first to select from our most recent addition  
of one and two bedroom  
apartments and utterly unique  
terrace residences. The views  
from many are incomparable  
and the value is unsurpassed.

From **\$350** Carpet Included.

- Subscription TV
- 24-hour gate-monitored entry
- Attached covered parking
- In residence storage & laundry
- Over 12 distinctly different floor plans
- Murwood club lodge
- Enormous pool & tennis courts
- Nature trails & natural ponds
- Furnished models open daily, 10 am-6 pm or by private showing

Located at the corner of Grand River and Drake, in Farmington Hills.  
**478-5533**



**400 Apartments For Rent**

**BROOKVIEW VILLAGE APTS**  
Palmer Rd. W of Hannan  
Plymouth School District  
1 & 2 Bedroom apartments & 2 Bed-  
room, 1 1/2 bath townhouses. Each unit  
completely air conditioned, carpeted,  
gas heat, all appliances, WESTING-  
HOUSE WASHER, DRYER in each in-  
dividual unit. Large walk-in closets  
Smoker units and townhouses with pri-  
vate patios & doorways. Ample park-  
ing. Gas utility included in rent. Village  
park with play area. No Pets.  
From \$250 & up Month.  
**RESIDENT MGR. 729-0900**  
10 to 6 Weekdays Sat. by Appt  
1715 Orchard Dr. Canton Twp

**Canterbury Apts.**  
**ONE MONTH FREE RENT**  
Starting at \$280  
Off Woodward Ave. opposite  
St. Joseph Mercy Hospital.  
• Balcony • Carpet  
• Pool • Security

**CHURCH HILL MANOR**  
Welcome Senior Citizens or Retirees  
Deluxe 1 bedroom, spacious apartment  
in downtown Plymouth. Available Mid-  
July. \$315 per mo. Call between 9AM-  
5PM. 421-6030 After 6PM, 277-2634

**CITY OF PLYMOUTH** large one bed-  
room apartment, heat, water, appli-  
ances, carpeting included Adults pre-  
ferred No pets \$275 458-6067

**CLAWSON** 1 bedroom, kitchen, living  
room, private basement, range, refrig-  
erator, large yard, 2 family ranch style.  
\$300 monthly 548-2400 or 879-8954

**CLAYMORE APTS.** Northwestern  
Franklin Hds. Sublet spacious 2 bed-  
room, 2 bath. Wheat carpet & custom  
drapes, vault garage. \$600 355-2264

**400 Apartments For Rent**

**CHARTERHOUSE Apartments**  
1 & 2 Bedroom

- Central Air
- Range
- Refrigerator
- Disposal
- Dishwasher
- Heat-Hot Water
- Carpeting
- TV Controlled
- Security & Guards
- Laundry & Storage Areas
- Tennis Courts
- Swimming Pool
- Party Room

16300 W. 9 Mile  
W. of Greenfield  
Office open  
Weekdays 9 thru 6  
Sat. & Sun. 12 thru 6  
**557-8100**

**400 Apartments For Rent**

**WALDENWOOD**  
Extraordinarily spacious 1 & 2 bedroom apart-  
ments 2 & 3 bedroom Townhouses featuring sep-  
arate breakfast rooms, family rooms, and 1 1/2  
baths on a uniquely wooded site

**FROM \$395 INCLUDING**

- HEAT AND COVERED PARKING
- CENTRAL AIR
- POOL AND CLUB HOUSE
- BALCONIES
- ENORMOUS STORAGE AREA

"A REPUTATION FOR METICULOUS MAINTENANCE"  
On West 10 Mile Rd., 1 block E. of Telegraph  
**353-1372**  
Weekdays 9-5 P.M., Weekends 11-4 P.M.

**400 Apartments For Rent**

**CHATHAM HILLS APT HOME**  
WITH ATTACHED GARAGE  
IN FARMINGTON  
On Old Grand River  
Bet. Drake & Halstead  
**1 & 2 BEDROOMS**  
from \$320  
Fabulous Clubhouse with year around  
swimming pool, saunas, sound &  
fireproofed construction & more.  
**OPEN DAILY 12-6pm**  
**476-8080**

**FARMINGTON HILLS 2 bedroom, 2**  
bath, air, balcony, carpet, 12 Mile Rd.  
between Middlebelt & Orchard Lake  
Rd. 405 Woodhues 851-0916

**400 Apartments For Rent**

**Luxury Apartment Living**  
Choose your new residence from one of our quality apart-  
ments or townhouses. Among the many features included are:  
central air conditioning, carpeting, dishwasher, pool, patio or  
balcony, laundry on each floor, and carport. Main office  
626-5595.

**The Pines**  
• 1 and 2 bedrooms • 1 and 2 baths • Gas heat included • Franklin  
Road north of Northwestern Hwy. • Resident Manager 357-0437.  
From...\$375

**400 Apartments For Rent**

**Oak Ridge**  
• 1 and 2 bedrooms • 1 and 2 baths • 7 spacious floor plans  
• Clubhouse • Berg Rd Service Drive, adjacent to Northwestern  
Hwy. • North of 10 1/2 Mile, East of Telegraph Rd. • Resident Man-  
ager 358-1885 From...\$360

**400 Apartments For Rent**

**Maple Tree**  
• 1 and 2 bedrooms • 1 and 2 baths • 7 spacious floor plans  
• Clubhouse • Located off Franklin Rd., South of Northwestern  
Hwy. and 12 Mile Roads • Resident Manager 354-0331  
From...\$360

**400 Apartments For Rent**

**Pine Ridge**  
• 1 and 2 bedrooms • 1 and 2 baths • 4 spacious floor plans  
• North side of 10 Mile Rd., West of Telegraph, adjacent to TEL-  
EX Shopping Center • Resident Manager 354-3930  
From...\$355

**400 Apartments For Rent**

**Pine-Aire**  
• 1, 2 and 3 bedrooms • 1 and 2 baths • 13 spacious floor plans  
• Clubhouse • North side 12 Mile East of Northwestern Hwy.  
• Resident Manager 357-1761  
From...\$340

**GRAND OPENING**

**In West Bloomfield**  
Extraordinary 1, 2 and 3 bedroom  
rental residences that feature up to  
2,800 square feet in a community of  
exceptional character and charm.  
Thru-unit design of all of these  
terrace and town homes provides  
private entry, double or triple  
exposures, kitchens with window  
views, in-unit storage and private  
laundry rooms, patios and  
balconies.  
Each of the 8 different  
Aldingbrooke plans is distin-  
guished by the unexpected: a one  
bedroom with 2 baths and a great  
room/den for example, a two  
bedroom 2 bath with a private  
dining room that is elegantly  
separated from the living room, a  
three bedroom with 2 1/2 or 3 baths  
with a great room and den or with a  
great room and fireplace. A great  
deal from which to choose!  
Attached garages, monitored  
gate house, club house, swimming  
pool and tennis courts.

**GRAND OPENING**

Extraordinary 1, 2 and 3 bedroom  
rental residences that feature up to  
2,800 square feet in a community of  
exceptional character and charm.  
Thru-unit design of all of these  
terrace and town homes provides  
private entry, double or triple  
exposures, kitchens with window  
views, in-unit storage and private  
laundry rooms, patios and  
balconies.  
Each of the 8 different  
Aldingbrooke plans is distin-  
guished by the unexpected: a one  
bedroom with 2 baths and a great  
room/den for example, a two  
bedroom 2 bath with a private  
dining room that is elegantly  
separated from the living room, a  
three bedroom with 2 1/2 or 3 baths  
with a great room and den or with a  
great room and fireplace. A great  
deal from which to choose!  
Attached garages, monitored  
gate house, club house, swimming  
pool and tennis courts.

**GRAND OPENING**

Extraordinary 1, 2 and 3 bedroom  
rental residences that feature up to  
2,800 square feet in a community of  
exceptional character and charm.  
Thru-unit design of all of these  
terrace and town homes provides  
private entry, double or triple  
exposures, kitchens with window  
views, in-unit storage and private  
laundry rooms, patios and  
balconies.  
Each of the 8 different  
Aldingbrooke plans is distin-  
guished by the unexpected: a one  
bedroom with 2 baths and a great  
room/den for example, a two  
bedroom 2 bath with a private  
dining room that is elegantly  
separated from the living room, a  
three bedroom with 2 1/2 or 3 baths  
with a great room and den or with a  
great room and fireplace. A great  
deal from which to choose!  
Attached garages, monitored  
gate house, club house, swimming  
pool and tennis courts.

**GRAND OPENING**

Extraordinary 1, 2 and 3 bedroom  
rental residences that feature up to  
2,800 square feet in a community of  
exceptional character and charm.  
Thru-unit design of all of these  
terrace and town homes provides  
private entry, double or triple  
exposures, kitchens with window  
views, in-unit storage and private  
laundry rooms, patios and  
balconies.  
Each of the 8 different  
Aldingbrooke plans is distin-  
guished by the unexpected: a one  
bedroom with 2 baths and a great  
room/den for example, a two  
bedroom 2 bath with a private  
dining room that is elegantly  
separated from the living room, a  
three bedroom with 2 1/2 or 3 baths  
with a great room and den or with a  
great room and fireplace. A great  
deal from which to choose!  
Attached garages, monitored  
gate house, club house, swimming  
pool and tennis courts.

**GRAND OPENING**

Extraordinary 1, 2 and 3 bedroom  
rental residences that feature up to  
2,800 square feet in a community of  
exceptional character and charm.  
Thru-unit design of all of these  
terrace and town homes provides  
private entry, double or triple  
exposures, kitchens with window  
views, in-unit storage and private  
laundry rooms, patios and  
balconies.  
Each of the 8 different  
Aldingbrooke plans is distin-  
guished by the unexpected: a one  
bedroom with 2 baths and a great  
room/den for example, a two  
bedroom 2 bath with a private  
dining room that is elegantly  
separated from the living room, a  
three bedroom with 2 1/2 or 3 baths  
with a great room and den or with a  
great room and fireplace. A great  
deal from which to choose!  
Attached garages, monitored  
gate house, club house, swimming  
pool and tennis courts.

**GRAND OPENING**

Extraordinary 1, 2 and 3 bedroom  
rental residences that feature up to  
2,800 square feet in a community of  
exceptional character and charm.  
Thru-unit design of all of these  
terrace and town homes provides  
private entry, double or triple  
exposures, kitchens with window  
views, in-unit storage and private  
laundry rooms, patios and  
balconies.  
Each of the 8 different  
Aldingbrooke plans is distin-  
guished by the unexpected: a one  
bedroom with 2 baths and a great  
room/den for example, a two  
bedroom 2 bath with a private  
dining room that is elegantly  
separated from the living room, a  
three bedroom with 2 1/2 or 3 baths  
with a great room and den or with a  
great room and fireplace. A great  
deal from which to choose!  
Attached garages, monitored  
gate house, club house, swimming  
pool and tennis courts.

**GRAND OPENING**

Extraordinary 1, 2 and 3 bedroom  
rental residences that feature up to  
2,800 square feet in a community of  
exceptional character and charm.  
Thru-unit design of all of these  
terrace and town homes provides  
private entry, double or triple  
exposures, kitchens with window  
views, in-unit storage and private  
laundry rooms, patios and  
balconies.  
Each of the 8 different  
Aldingbrooke plans is distin-  
guished by the unexpected: a one  
bedroom with 2 baths and a great  
room/den for example, a two  
bedroom 2 bath with a private  
dining room that is elegantly  
separated from the living room, a  
three bedroom with 2 1/2 or 3 baths  
with a great room and den or with a  
great room and fireplace. A great  
deal from which to choose!  
Attached garages, monitored  
gate house, club house, swimming  
pool and tennis courts.

**GRAND OPENING**

Extraordinary 1, 2 and 3 bedroom  
rental residences that feature up to  
2,800 square feet in a community of  
exceptional character and charm.  
Thru-unit design of all of these  
terrace and town homes provides  
private entry, double or triple  
exposures, kitchens with window  
views, in-unit storage and private  
laundry rooms, patios and  
balconies.  
Each of the 8 different  
Aldingbrooke plans is distin-  
guished by the unexpected: a one  
bedroom with 2 baths and a great  
room/den for example, a two  
bedroom 2 bath with a private  
dining room that is elegantly  
separated from the living room, a  
three bedroom with 2 1/2 or 3 baths  
with a great room and den or with a  
great room and fireplace. A great  
deal from which to choose!  
Attached garages, monitored  
gate house, club house, swimming  
pool and tennis courts.

**GRAND OPENING**

Extraordinary 1, 2 and 3 bedroom  
rental residences that feature up to  
2,800 square feet in a community of  
exceptional character and charm.  
Thru-unit design of all of these  
terrace and town homes provides  
private entry, double or triple  
exposures, kitchens with window  
views, in-unit storage and private  
laundry rooms, patios and  
balconies.  
Each of the 8 different  
Aldingbrooke plans is distin-  
guished by the unexpected: a one  
bedroom with 2 baths and a great  
room/den for example, a two  
bedroom 2 bath with a private  
dining room that is elegantly  
separated from the living room, a  
three bedroom with 2 1/2 or 3 baths  
with a great room and den or with a  
great room and fireplace. A great  
deal from which to choose!  
Attached garages, monitored  
gate house, club house, swimming  
pool and tennis courts.

**400 Apartments For Rent**

## FARMINGTON HILLS THE GATEWAYS APARTMENTS

A DISTINCTIVE PLACE TO LIVE  
**TWO BEDROOMS FROM \$380**  
Balcony, front-free refrigerator, self cleaning oven, air conditioned, shag carpet, beautifully rolling hills, great one club house & entertainment center. Tennis & other sport facilities.  
**12 MILE RD. W. OF MIDDLEBELT Adult Community No Pets**  
**474-6082**  
**FARMINGTON HILLS-Muirwood Sublet 2** bedroom apartment on water Clean \$375 a month. Days, 352-4873. Evenings, 477-7797

**400 Apartments For Rent**

**FARMINGTON HILLS-Terrace Home to Sublet, Muirwood Apartments, \$450/month Days, 557-7700 ext. 541**

**400 Apartments For Rent**

**Farmington Hills WALNUT CREEK APARTMENTS IMMEDIATE OCCUPANCY**  
One bedroom apartments from \$285. Open Daily & Weekends. Middlebelt, just south of 10 Mile Rd. 477-4066

**400 Apartments For Rent**

**FARMINGTON LIVONIA**  
Luxury apartments, dishwasher security, interior, sound proof, pool, club house. Sorry no pets. Adult community 1 & 2 bedrooms available.  
**OCCUPANCY** June, July, August. **COME OUT & SEE US**  
Merriman Rd. (Orchard Lake Rd.)  
Just one block S. of 8 Mile Rd.  
**MERRIMAN PARK APTS**  
Middlebelt, just south of 10 Mile Rd.  
The most beautiful garden apart-  
ments in Mich.  
**FARMINGTON HILLS, large 1 bed-**  
room, partially furnished. No pets. \$275  
per month, plus deposit, references re-  
quired. Available mid August 455-2926

**400 Apartments For Rent**

**CLAYMORE APTS. Northwestern**  
Franklin Hds. Sublet spacious 2 bed-  
room, 2 bath. Wheat carpet & custom  
drapes, vault garage. \$600 355-2264

**400 Apartments For Rent**

**GARDEN CITY**  
Maplewood Middlebelt  
1 bedroom, heat included \$250  
588-4703 or after 4PM, 427-8396

**400 Apartments For Rent**

**GREENTFIELD** Lincoln Area. Spacious 2 1/2 bedroom apartments. Carpeting, appliances, heat & hot water included, carport, no pets. From \$345.  
559-7935 or 626-4196

**400 Apartments For Rent**

**Hillcrest Club**  
12382 Risman Dr.  
Plymouth Rd. & Haggerty  
In PLYMOUTH  
**1 & 2 Bedrooms**  
from \$260  
**453-7144**

**400 Apartments For Rent**

**GREENTFIELD-13 MILE AREA**  
Spacious 1 bedroom apartments. Car-  
pet, appliances, utilities except electric  
\$325 & \$315 per month. Middle age  
preferred 435-0373

**400 Apartments For Rent**

**GREENFIELD-13 MILE AREA**  
Spacious 1 bedroom apartments. Car-  
pet, appliances, utilities except electric  
\$325 & \$315 per month. Middle age  
preferred 435-0373

**400 Apartments For Rent**

**GREENFIELD-13 MILE AREA**  
Spacious 1 bedroom apartments. Car-  
pet, appliances, utilities except electric  
\$325 & \$315 per month. Middle age  
preferred 435-0373

**400 Apartments For Rent**

**GREENFIELD-13 MILE AREA**  
Spacious 1 bedroom apartments. Car-  
pet, appliances, utilities except electric  
\$325 & \$315 per month. Middle age  
preferred 435-0373

**400 Apartments For Rent**

**GREENFIELD-13 MILE AREA**  
Spacious 1 bedroom apartments. Car-  
pet, appliances, utilities except electric  
\$325 & \$315 per month. Middle age  
preferred 435-0373

**400 Apartments For Rent**

**GREENFIELD-13 MILE AREA**  
Spacious 1 bedroom apartments. Car-  
pet, appliances, utilities except electric  
\$325 & \$315 per month. Middle age  
preferred 435-0373

**400 Apartments For Rent**

**GREENFIELD-13 MILE AREA**  
Spacious 1 bedroom apartments. Car-  
pet, appliances, utilities except electric  
\$325 & \$315 per month. Middle age  
preferred 435-0373

**400 Apartments For Rent**

**GREENFIELD-13 MILE AREA**  
Spacious 1 bedroom apartments. Car-  
pet, appliances, utilities except electric  
\$325 & \$315 per month. Middle age  
preferred 435-0373

**400 Apartments For Rent**

**GREENFIELD-13 MILE AREA**  
Spacious 1 bedroom apartments. Car-  
pet, appliances, utilities except electric  
\$325 & \$315 per month. Middle age  
preferred 435-0373

**400 Apartments For Rent**

**GREENFIELD-13 MILE AREA**  
Spacious 1 bedroom apartments. Car-  
pet, appliances, utilities except electric  
\$325 & \$315 per month. Middle age  
preferred 435-0373

**400 Apartments For Rent**

**GREENFIELD-13 MILE AREA**  
Spacious 1 bedroom apartments. Car-  
pet, appliances, utilities except electric  
\$325 & \$315 per month. Middle age  
preferred 435-0373

**400 Apartments For Rent**

## CRANBROOK CENTRE GARDEN APARTMENTS

Southfield - Between 12 & 13  
Mile Rds., Southfield Rd.  
1 & 2 bedroom apts. Central air,  
carpeting, GE appliances including  
dishwasher, extra storage, carport,  
swimming pool, utilities except electric-  
ity. On premises management,  
away from road traffic.  
**642-8777 642-2500**

**400 Apartments For Rent**

**DEARBORN CLUB**  
In Dearborn Heights  
5784 Inkster Road,  
Just N. of Ford Road  
**1 Bedroom Apt.**  
**2 Bedroom Townhouse**  
FROM \$260  
Includes Heat, Carpeting,  
Air Conditioning, Pool  
**561-3593**

**400 Apartments For Rent**

**DOWNTOWN Plymouth** upper 1 bed-  
room, partially furnished. No pets. \$275  
per month, plus deposit, references re-  
quired. Available mid August 455-2926

**400 Apartments For Rent**

**EFFICIENCY apartment, Downtown**  
Rochester, newly decorated, \$275  
month. All utilities included 651-7842.  
Evenings, 651-5588

**400 Apartments For Rent**

**FAMILY AFFAIR**  
3 bedroom townhouses on lake site  
Children welcome. Rochester Rd. 1/2  
mile N. of Square Lake Rd. Troy  
879-2466 (Office closed Tuesdays)

**400 Apartments For Rent**

**FARMINGTON HILLS, large 1 bed-**  
room, heat and water, drapes, carpet-  
ing, central heat & air. Laundry facili-  
ties. 474-2552

**400 Apartments For Rent**

**FARMINGTON HILLS one bedroom,**  
central air, appliances, carpeting,  
drapes, at \$280 398-3686

**400 Apartments For Rent**

**FARMINGTON HILLS APARTMENT**  
For Sub-Lease, now thru Nov. 30th 2  
bedrooms, 2 baths, drapes, pool and ten-  
nis court. 474-2474 or 261-6965

**400 Apartments For Rent**

**GARDEN CITY**  
Maplewood Middlebelt  
1 bedroom, heat included \$250  
588-4703 or after 4PM, 427-8396

**400 Apartments For Rent**

**GREENTFIELD** Lincoln Area. Spacious  
2 1/2 bedroom apartments. Carpeting,  
appliances, heat & hot water in-  
cluded, carport, no pets. From \$345.  
559-7935 or 626-4196

**400 Apartments For Rent**

**Hillcrest Club**  
12382 Risman Dr.  
Plymouth Rd. & Haggerty  
In PLYMOUTH  
**1 & 2 Bedrooms**  
from \$260  
**453-7144**

**400 Apartments For Rent**

**GREENTFIELD** Lincoln Area. Spacious  
2 1/2 bedroom apartments. Carpeting,  
appliances, heat & hot water in-  
cluded, carport, no pets. From \$345.  
559-7935 or 626-4196

**400 Apartments For Rent**

**GREENTFIELD** Lincoln Area. Spacious  
2 1/2 bedroom apartments. Carpeting,  
appliances, heat & hot water in-  
cluded, carport, no pets. From \$345.  
559-7935 or 626-4196

**400 Apartments For Rent**

**GREENTFIELD</**

# CLASSIFIED REAL ESTATE

## 400 Apartments For Rent

**STONERIDGE MANOR APTS.**  
Three 1 bedroom apartments \$335. Close to downtown Farmington. Freedom Road, W. of Orchard Lake Rd. S. of Grand River. 477-4143

**SUBLET** Honeytree apartment, 2 bedrooms with den 1-275 & Joy Rd area. 453-917.

**TELEGRAPH PLYMOUTH GLEN COVE**  
Desirable 1 bedroom apartment. Carpet, drapes, air \$260. Adults, no pets. 538-2497

**THE HEAT'S FREE AT CHARLES HAMLET**  
1 & 2 Bedrooms from \$300  
Large spacious units, carports, walk-in closets, air conditioning, pool, balconies or patios. Hampton community facilities.  
Mon. thru Fri. 10-5  
**852-0311**  
VILLAGE GREEN MANAGEMENT CO.

**The Village Apartments**  
GARDEN CITY & WESTLAND AREA  
One bedroom, \$275  
Two bedroom, \$295  
includes carpeting, drapes, air conditioning, stove, refrigerator, gas heat and water. No pets.  
9 AM - 5 PM Weekdays only  
**425-0930**

**THREE OAKS**  
Troys newest luxury apartment community 1 & 2 bedroom apartments. All appliances, carports, community building, pool, tennis courts & rural setting. 1/2 Mile E. of Crooks on Waltham at 1-75.  
OPEN Mon thru Fri 10 to 6  
Sat. 10 to 4  
Phone 362-4088

**TROY ROYAL OAK AREA** 1 bedroom with pool, carpet, appliances, air, drapes, beautiful garden setting, \$300 per month. 526-5457

**TROY SOMERSET AREA**  
Spacious 1 bedroom apartment \$320 monthly carpeted, decorated, air conditioned and pool. Village Apartments 362-1698

**TWIN LAKES**  
8711 Candlewood just off of Grand River, east of I-96  
**1 & 2 Bedrooms FROM \$190**  
per month rent in scenic Brighton. All apartments fully carpeted and include all appliances.  
Call Kris Cain at the model - 227-6392  
or Roy Mantav at 227-1529

**VILLAGE GREEN OF PLYMOUTH**  
1 bedroom apartment for mature adults FROM \$265  
Ask for Linda 769-1313

**Village Green OF BELLEVILLE**  
1 & 2 Bedrooms FROM \$285  
An All Adult Community Heat Included.  
699-2040  
Weekdays 9 to 5, Sat. 9 to 12

**VILLAGE MANOR APARTMENTS**  
A Nice Place to Live in Oxford 2 Blocks off M-24  
Spacious Luxurious Suites 1 BEDROOM APARTMENT FROM \$240.  
Very Clean-Well Maintained Beautifully Landscaped With Pond Tennis Courts Individual gardens spaces. No Pets, Heat-Water Incl'd Efficiency Apartment \$215 Immediate Occupancy Owner Manager  
Office Hours 10Am-6Pm Mon. through Fri. 10Am-1Pm Sat. 628-2375

**VILLAGE SQUIRE**  
On Ford Rd. Just E. of I-275  
**1 & 2 BEDROOMS from \$260**  
Central air, fully carpeted, sound conditioned, pool & sauna. 453-8773

**WALLED LAKE, 1 and 2 bedroom**  
Apts. with balcony, central air, heat included. Sauna, recreation room, exercise room and beach privileges. For information call: 534-5999

**Walton Square ONE MONTH FREE RENT**  
Starting at \$260  
In Pontiac near I-75. Newly decorated 1 and 2 bedroom apts. Carpeting, air conditioning, security guard, etc.  
**373-1400**

**WATERVIEW FARMS**  
On Pontiac Trail E. of Beck Rd.  
**1 BEDROOM - \$260**  
Central Air, carpeted, tennis court pool & clubhouse  
**624-0004**

**WAYNE APARTMENTS, 33402**  
Michigan Ave., newly decorated, carpeted one bedroom, \$215 plus utilities. Adults preferred. 595-3622

**WESTLAND AREA** Adults preferred. No pets. 1 bedroom, \$250 includes heat, carpet, drapes, appliances. 721-0508

**WESTLAND AREA**  
Spacious 1 & 2 bedroom apartments from \$285 monthly. Carpeted, decorated, air condition. & in lovely area. Country Court Apartments 721-0508

**WESTLAND**  
Clean, quiet, attractive 1 bedroom. Carpet, drapes, air, utilities, appliances \$270. Six month lease available \$448. to move in. 591-0165

**WESTLAND**  
Near Westland shopping center. Large luxury 1 & 2 bedroom apartments, some with fireplace, carpeted. Air, dishwasher, eating area in kitchen, club house, pool, lighted tennis courts, Venoy House Apartments. Between 10Am-5Pm daily 261-7394

**WESTLAND 2 bedrooms, modern, large, lovely duplex living room, 19121, carpeted, laundry room, yard, children \$300 per month.** 334-9237

**WIXOM**  
Terrific apartment to sublease. Only \$135 security deposit. \$24 less a month than original rent. pay \$250 mo 2 bedrooms, air, all appliances, pool, carpeting. 624-3133

**12 MILE - LAHSER LAUREL WOODS**  
Luxurious adult community 2 bedroom, 2 bath townhouse with own laundry room & storage. Clubhouse & pool. 357-3174

**9 MILE - COOLIDGE AREA, modern 2 bedroom apartment, carpeting, appliances, air conditioned, parking. No pets. \$230** 626-4196

**ATTRACTIVE ONE BEDROOM**  
Executive apartment. Short term lease. Linens, dishes, TV, pool, air. 14 Mile & Crooks \$475. 435-6281. 280-0398

## 400 Apartments For Rent

**WESTLAND AREA** Adults preferred. No pets. 1 bedroom, \$250 includes heat, carpet, drapes, appliances. 721-0508

**WESTLAND AREA**  
Spacious 1 & 2 bedroom apartments from \$285 monthly. Carpeted, decorated, air condition. & in lovely area. Country Court Apartments 721-0508

**WESTLAND**  
Clean, quiet, attractive 1 bedroom. Carpet, drapes, air, utilities, appliances \$270. Six month lease available \$448. to move in. 591-0165

**WESTLAND**  
Near Westland shopping center. Large luxury 1 & 2 bedroom apartments, some with fireplace, carpeted. Air, dishwasher, eating area in kitchen, club house, pool, lighted tennis courts, Venoy House Apartments. Between 10Am-5Pm daily 261-7394

**WESTLAND 2 bedrooms, modern, large, lovely duplex living room, 19121, carpeted, laundry room, yard, children \$300 per month.** 334-9237

**WIXOM**  
Terrific apartment to sublease. Only \$135 security deposit. \$24 less a month than original rent. pay \$250 mo 2 bedrooms, air, all appliances, pool, carpeting. 624-3133

**12 MILE - LAHSER LAUREL WOODS**  
Luxurious adult community 2 bedroom, 2 bath townhouse with own laundry room & storage. Clubhouse & pool. 357-3174

**9 MILE - COOLIDGE AREA, modern 2 bedroom apartment, carpeting, appliances, air conditioned, parking. No pets. \$230** 626-4196

**ATTRACTIVE ONE BEDROOM**  
Executive apartment. Short term lease. Linens, dishes, TV, pool, air. 14 Mile & Crooks \$475. 435-6281. 280-0398

**BIRMINGHAM AREA**  
Monthly Leases \$395 & Up LUXURY  
One and two bedroom apartments completely furnished. Colored TVs and maid service available.  
THE MANORS  
**280-2510**

**400 Apartments For Rent**  
**UTICA**  
New 2 bedroom 1100 sq ft townhouse. Washer and dryer. Immediate occupancy. \$400 per Mo. Call 781-2120

**VILLAGE GREEN OF PLYMOUTH**  
1 bedroom apartment for mature adults FROM \$265  
Ask for Linda 769-1313

**Village Green OF BELLEVILLE**  
1 & 2 Bedrooms FROM \$285  
An All Adult Community Heat Included.  
699-2040  
Weekdays 9 to 5, Sat. 9 to 12

**VILLAGE MANOR APARTMENTS**  
A Nice Place to Live in Oxford 2 Blocks off M-24  
Spacious Luxurious Suites 1 BEDROOM APARTMENT FROM \$240.  
Very Clean-Well Maintained Beautifully Landscaped With Pond Tennis Courts Individual gardens spaces. No Pets, Heat-Water Incl'd Efficiency Apartment \$215 Immediate Occupancy Owner Manager  
Office Hours 10Am-6Pm Mon. through Fri. 10Am-1Pm Sat. 628-2375

**VILLAGE SQUIRE**  
On Ford Rd. Just E. of I-275  
**1 & 2 BEDROOMS from \$260**  
Central air, fully carpeted, sound conditioned, pool & sauna. 453-8773

**WALLED LAKE, 1 and 2 bedroom**  
Apts. with balcony, central air, heat included. Sauna, recreation room, exercise room and beach privileges. For information call: 534-5999

**Walton Square ONE MONTH FREE RENT**  
Starting at \$260  
In Pontiac near I-75. Newly decorated 1 and 2 bedroom apts. Carpeting, air conditioning, security guard, etc.  
**373-1400**

**WATERVIEW FARMS**  
On Pontiac Trail E. of Beck Rd.  
**1 BEDROOM - \$260**  
Central Air, carpeted, tennis court pool & clubhouse  
**624-0004**

**WAYNE APARTMENTS, 33402**  
Michigan Ave., newly decorated, carpeted one bedroom, \$215 plus utilities. Adults preferred. 595-3622

**WESTLAND AREA** Adults preferred. No pets. 1 bedroom, \$250 includes heat, carpet, drapes, appliances. 721-0508

**WESTLAND AREA**  
Spacious 1 & 2 bedroom apartments from \$285 monthly. Carpeted, decorated, air condition. & in lovely area. Country Court Apartments 721-0508

**WESTLAND**  
Clean, quiet, attractive 1 bedroom. Carpet, drapes, air, utilities, appliances \$270. Six month lease available \$448. to move in. 591-0165

**WESTLAND**  
Near Westland shopping center. Large luxury 1 & 2 bedroom apartments, some with fireplace, carpeted. Air, dishwasher, eating area in kitchen, club house, pool, lighted tennis courts, Venoy House Apartments. Between 10Am-5Pm daily 261-7394

**WESTLAND 2 bedrooms, modern, large, lovely duplex living room, 19121, carpeted, laundry room, yard, children \$300 per month.** 334-9237

**WIXOM**  
Terrific apartment to sublease. Only \$135 security deposit. \$24 less a month than original rent. pay \$250 mo 2 bedrooms, air, all appliances, pool, carpeting. 624-3133

**12 MILE - LAHSER LAUREL WOODS**  
Luxurious adult community 2 bedroom, 2 bath townhouse with own laundry room & storage. Clubhouse & pool. 357-3174

## 400 Furnished Apts. For Rent

**FURNISHED EXECUTIVE APARTMENTS & CONDOS**  
1 bedroom \$375-\$450  
2 bedroom \$475-\$550  
3 bedroom, 2 bath \$575-\$650  
Several locations. 1 yr. lease. New furniture. Large selection, warehouse showroom. Short or long term lease. GLOBE INTERIOR RENTALS 1100 E. Maple (13 Mile), Troy W. of I-75 588-1800

**LUXURY EXECUTIVE APPTS.**  
Completely Furnished - Monthly Leases. Maid Service Available 280-1820

**MONTHLY LEASES**  
REASONABLE RATES  
Beautiful full size apartments. Completely furnished in excellent locations.

**ROYAL CHAMBERS**  
334-1502

**New Studio Apts. \$275**  
Deluxe apartments, air laundry and storage facilities, off street parking. Downtown Royal Oak. Monthly leases available. Adults preferred, no pets. Applicants must make \$12,000 or more per year to apply.  
Call Florence 398-8687  
Or Mike 549-8320

**OLD REDFORD**  
Basement apartment for man over 30. Furnished, all utilities \$165. Executive Rental 334-4514

**ONE Bedroom basement apartment, private entrance, completely furnished, \$200 includes utilities. 12 Mile-Greenfield area. Single only.** 595-8271

**SPECIAL WEEKLY RATES**  
Motel Room & Efficiency Apartments 1729 Telegraph Rd. (1 block S. of Grand River) - Mayflower Motel

**STUDIO APARTMENT in downtown Birmingham** historic home. New appliances, decor. Heat & water furnished, air, suitable for 1 person \$285 monthly. 646-5143

**WAYNE** Clean attractive efficiency apartment \$55 per week. Single gentlemen preferred. No Pets. Private entrance, private bath. Call 10Am-7Pm 595-6778

**WAYNE** 1 bedroom furnished apartment \$230 per month including all utilities. \$150 security deposit. Adults preferred. No pets. Call 12Pm-7Pm 326-8474

## 400 Apartments For Rent

**UTICA**  
New 2 bedroom 1100 sq ft townhouse. Washer and dryer. Immediate occupancy. \$400 per Mo. Call 781-2120

**VILLAGE GREEN OF PLYMOUTH**  
1 bedroom apartment for mature adults FROM \$265  
Ask for Linda 769-1313

**Village Green OF BELLEVILLE**  
1 & 2 Bedrooms FROM \$285  
An All Adult Community Heat Included.  
699-2040  
Weekdays 9 to 5, Sat. 9 to 12

**VILLAGE MANOR APARTMENTS**  
A Nice Place to Live in Oxford 2 Blocks off M-24  
Spacious Luxurious Suites 1 BEDROOM APARTMENT FROM \$240.  
Very Clean-Well Maintained Beautifully Landscaped With Pond Tennis Courts Individual gardens spaces. No Pets, Heat-Water Incl'd Efficiency Apartment \$215 Immediate Occupancy Owner Manager  
Office Hours 10Am-6Pm Mon. through Fri. 10Am-1Pm Sat. 628-2375

**VILLAGE SQUIRE**  
On Ford Rd. Just E. of I-275  
**1 & 2 BEDROOMS from \$260**  
Central air, fully carpeted, sound conditioned, pool & sauna. 453-8773

**WALLED LAKE, 1 and 2 bedroom**  
Apts. with balcony, central air, heat included. Sauna, recreation room, exercise room and beach privileges. For information call: 534-5999

**Walton Square ONE MONTH FREE RENT**  
Starting at \$260  
In Pontiac near I-75. Newly decorated 1 and 2 bedroom apts. Carpeting, air conditioning, security guard, etc.  
**373-1400**

**WATERVIEW FARMS**  
On Pontiac Trail E. of Beck Rd.  
**1 BEDROOM - \$260**  
Central Air, carpeted, tennis court pool & clubhouse  
**624-0004**

**WAYNE APARTMENTS, 33402**  
Michigan Ave., newly decorated, carpeted one bedroom, \$215 plus utilities. Adults preferred. 595-3622

**WESTLAND AREA** Adults preferred. No pets. 1 bedroom, \$250 includes heat, carpet, drapes, appliances. 721-0508

**WESTLAND AREA**  
Spacious 1 & 2 bedroom apartments from \$285 monthly. Carpeted, decorated, air condition. & in lovely area. Country Court Apartments 721-0508

**WESTLAND**  
Clean, quiet, attractive 1 bedroom. Carpet, drapes, air, utilities, appliances \$270. Six month lease available \$448. to move in. 591-0165

**WESTLAND**  
Near Westland shopping center. Large luxury 1 & 2 bedroom apartments, some with fireplace, carpeted. Air, dishwasher, eating area in kitchen, club house, pool, lighted tennis courts, Venoy House Apartments. Between 10Am-5Pm daily 261-7394

**WESTLAND 2 bedrooms, modern, large, lovely duplex living room, 19121, carpeted, laundry room, yard, children \$300 per month.** 334-9237

## 402 Furnished Apts. For Rent

**BIRMINGHAM** - spacious 2 bedroom, completely & comfortably furnished, all utilities/appliances, long or short term, 647-4586, 524-9574 651-5599

**CLARKSON VILLAGE** lovely old home, 2 bedrooms up, 1 bedroom & bath down. Living room, dining room & kitchen. \$450 month plus utilities. 334-3900

**CLOSE** in town Birmingham, 3 bedroom house on a pleasant street. Kitchen appliances, fenced yard. Available immediately. 642-4934

**CUTE** 2 bedroom house in excellent area of Westland. No pets, available immediately. Call after 4PM 981-1666

**DOWNTOWN ROCHESTER**, 3 possible 4 bedroom home \$350 per mo. Tenant pays all utilities. Mature, Quiet Tenants Only! 651-8937

**Executive Rentals**  
BIRMINGHAM - 4 bedroom colonial plus den, \$1000 a month.  
FARMINGTON HILLS - 4 bedroom colonial plus den, \$925 a month.  
FARMINGTON HILLS - 3 bedroom ranch, \$800 a month.  
FRANKLIN - 4 bedroom contemporary, \$875 a month.  
NORTHVILLE - 4 bedroom colonial, \$800 a month.  
WEST BLOOMFIELD - Pebble Creek Condo, two 3 bedroom units plus den, \$1000 a month.  
Approval subject to credit report, employment letter and references.  
FOR DETAILS CALL BOB LYNDALL

**Chamberlain**  
6 2 6 - 9 1 0 0

**EXECUTIVE 4 bedroom Colonial in exclusive Troy location.** Library, Central Air, firestone fireplace family room. Call for details 9950 month

**Chamberlain**  
6 4 7 - 5 1 0 0

**CASS LAKE HOME**  
Three bedrooms, 2 baths, family room with fireplace, large deck & boat dock. \$650 per month.  
Call evenings or weekends 682-1500

## 400 Apartments For Rent

**UTICA**  
New 2 bedroom 1100 sq ft townhouse. Washer and dryer. Immediate occupancy. \$400 per Mo. Call 781-2120

**VILLAGE GREEN OF PLYMOUTH**  
1 bedroom apartment for mature adults FROM \$265  
Ask for Linda 769-1313

**Village Green OF BELLEVILLE**  
1 & 2 Bedrooms FROM \$285  
An All Adult Community Heat Included.  
699-2040  
Weekdays 9 to 5, Sat. 9 to 12

**VILLAGE MANOR APARTMENTS**  
A Nice Place to Live in Oxford 2 Blocks off M-24  
Spacious Luxurious Suites 1 BEDROOM APARTMENT FROM \$240.  
Very Clean-Well Maintained Beautifully Landscaped With Pond Tennis Courts Individual gardens spaces. No Pets, Heat-Water Incl'd Efficiency Apartment \$215 Immediate Occupancy Owner Manager  
Office Hours 10Am-6Pm Mon. through Fri. 10Am-1Pm Sat. 628-2375

**VILLAGE SQUIRE**  
On Ford Rd. Just E. of I-275  
**1 & 2 BEDROOMS from \$260**  
Central air, fully carpeted, sound conditioned, pool & sauna. 453-8773

**WALLED LAKE, 1 and 2 bedroom**  
Apts. with balcony, central air, heat included. Sauna, recreation room, exercise room and beach privileges. For information call: 534-5999

**Walton Square ONE MONTH FREE RENT**  
Starting at \$260  
In Pontiac near I-75. Newly decorated 1 and 2 bedroom apts. Carpeting, air conditioning, security guard, etc.  
**373-1400**

**WATERVIEW FARMS**  
On Pontiac Trail E. of Beck Rd.  
**1 BEDROOM - \$260**  
Central Air, carpeted, tennis court pool & clubhouse  
**624-0004**

**WAYNE APARTMENTS, 33402**  
Michigan Ave., newly decorated, carpeted one bedroom, \$215 plus utilities. Adults preferred. 595-3622

**WESTLAND AREA** Adults preferred. No pets. 1 bedroom, \$250 includes heat, carpet, drapes, appliances. 721-0508

**WESTLAND AREA**  
Spacious 1 & 2 bedroom apartments from \$285 monthly. Carpeted, decorated, air condition. & in lovely area. Country Court Apartments 721-0508

**WESTLAND**  
Clean, quiet, attractive 1 bedroom. Carpet, drapes, air, utilities, appliances \$270. Six month lease available \$448. to move in. 591-0165

**WESTLAND**  
Near Westland shopping center. Large luxury 1 & 2 bedroom apartments, some with fireplace, carpeted. Air, dishwasher, eating area in kitchen, club house, pool, lighted tennis courts, Venoy House Apartments. Between 10Am-5Pm daily 261-7394

**WESTLAND 2 bedrooms, modern, large, lovely duplex living room, 19121, carpeted, laundry room, yard, children \$300 per month.** 334-9237

## 404 Houses For Rent

**CHERRY HILL & John Dely** area. Newly decorated 3 bedroom brick ranch, basement & garage, available Aug. 1 \$410/month 277-4242 274-6093

**CLARKSON VILLAGE** lovely old home, 2 bedrooms up, 1 bedroom & bath down. Living room, dining room & kitchen. \$450 month plus utilities. 334-3900

**CLOSE** in town Birmingham, 3 bedroom house on a pleasant street. Kitchen appliances, fenced yard. Available immediately. 642-4934

**CUTE** 2 bedroom house in excellent area of Westland. No pets, available immediately. Call after 4PM 981-1666

**DOWNTOWN ROCHESTER**, 3 possible 4 bedroom home \$350 per mo. Tenant pays all utilities. Mature, Quiet Tenants Only! 651-8937

**Executive Rentals**  
BIRMINGHAM - 4 bedroom colonial plus den, \$1000 a month.  
FARMINGTON HILLS - 4 bedroom colonial plus den, \$925 a month.  
FARMINGTON HILLS - 3 bedroom ranch, \$800 a month.  
FRANKLIN - 4 bedroom contemporary, \$875 a month.  
NORTHVILLE - 4 bedroom colonial, \$800 a month.  
WEST BLOOMFIELD - Pebble Creek Condo, two 3 bedroom units plus den, \$1000 a month.  
Approval subject to credit report, employment letter and references.  
FOR DETAILS CALL BOB LYNDALL

**Chamberlain**  
6 2 6 - 9 1 0 0

**EXECUTIVE 4 bedroom Colonial in exclusive Troy location.** Library, Central Air, firestone fireplace family room. Call for details 9950 month

**Chamberlain**  
6 4 7 - 5 1 0 0

## 400 Apartments For Rent

**UTICA**  
New 2 bedroom 1100 sq ft townhouse. Washer and dryer. Immediate occupancy. \$400 per Mo. Call 781-2120

**VILLAGE GREEN OF PLYMOUTH**  
1 bedroom apartment for mature adults FROM \$265  
Ask for Linda 769-1313

**Village Green OF BELLEVILLE**  
1 & 2 Bedrooms FROM \$285  
An All Adult Community Heat Included.  
699-2040  
Weekdays 9 to 5, Sat. 9 to 12

**VILLAGE MANOR APARTMENTS**  
A Nice Place to Live in Oxford 2 Blocks off M-24  
Spacious Luxurious Suites 1 BEDROOM APARTMENT FROM \$240.  
Very Clean-Well Maintained Beautifully Landscaped With Pond Tennis Courts Individual gardens spaces. No Pets, Heat-Water Incl'd Efficiency Apartment \$215 Immediate Occupancy Owner Manager  
Office Hours 10Am-6Pm Mon. through Fri. 10Am-1Pm Sat. 628-2375

**VILLAGE SQUIRE**  
On Ford Rd. Just E. of I-275  
**1 & 2 BEDROOMS from \$260**  
Central air, fully carpeted, sound conditioned, pool & sauna. 453-8773

**WALLED LAKE, 1 and 2 bedroom**  
Apts. with balcony, central air, heat included. Sauna, recreation room, exercise room and beach privileges. For information call: 534-5999

**Walton Square ONE MONTH FREE RENT**  
Starting at \$260  
In Pontiac near I-75. Newly decorated 1 and 2 bedroom apts. Carpeting, air conditioning, security guard, etc.  
**373-1400**

**WATERVIEW FARMS**  
On Pontiac Trail E. of Beck Rd.  
**1 BEDROOM - \$260**  
Central Air, carpeted, tennis court pool & clubhouse  
**624-0004**

**WAYNE APARTMENTS, 33402**  
Michigan Ave., newly decorated, carpeted one bedroom, \$215 plus utilities. Adults preferred. 595-3622

**WESTLAND AREA** Adults preferred. No pets. 1 bedroom, \$250 includes heat, carpet, drapes, appliances. 721-0508

**WESTLAND AREA**  
Spacious 1 & 2 bedroom apartments from \$285 monthly. Carpeted, decorated, air condition. & in lovely area. Country Court Apartments 721-0508

**WESTLAND**  
Clean, quiet, attractive 1 bedroom. Carpet, drapes, air, utilities, appliances \$270. Six month lease available \$448. to move in. 591-0165

**WESTLAND**  
Near Westland shopping center. Large luxury 1 & 2 bedroom apartments, some with fireplace, carpeted. Air, dishwasher, eating area in kitchen, club house, pool, lighted tennis courts, Venoy House Apartments. Between 10Am-5Pm daily 261-7

404 Houses For Rent

BIRMINGHAM, 5 bedroom, 2 1/2 baths, family room, 2 attached car garage, newly decorated, Bloomfield Hills schools. \$750 month plus deposit. Also option to purchase if desired. 457-4022

404 Houses For Rent

NORTH OAK PARK 4 bedroom colonial house, 2 1/2 baths, paved family room, modern kitchen with appliances, central air, carpeted, hard wood floors, centrally carpeted, \$450 per month. Call Lincoln Park Apartments 424-9922

404 Houses For Rent

WESTLAND-Livonia schools, 3 bedroom Ranch, \$425 per month + 2 children. References No pets - 2 Security 278-9346

412 Townhouses-Condos

AVAILABLE 12 Mile-Telegraph Special Discount To new residents of \$100 per month for 2 months on a 12 month lease. We pay all HEAT BILLS. Offer good on last 2 units thru July 31, 1980

412 Townhouses-Condos

TWO BEDROOM condo, Troy, Northfield Hills, \$490 monthly plus security. Fully furnished cottage on water, excellent fishing, swimming lake, tennis, horseback riding nearby. Boat dockage available. 879-1361

416 Vacation Rentals

ELIZABETH LAKE near Kreego harbor. Small cabins for rent \$90 weekly. Boat dockage available. 535-9149

420 Rooms For Rent

REDFORD AREA Room with privileges or room, board and laundry for elderly. 535-9149

424 Office & Business Space

In Need of Birmingham Address & Phone? Partitioned work stations available in luxury office, month to month with security. 647-0977

430 Wanted To Rent

WORKING COUPLE needs 2 bedroom home immediately with fireplace, basement, garage. In Southfield, Oak Park, Roseville Park, Anytown. 851-4847

404 Houses For Rent

BIRMINGHAM, 5 bedroom, 2 1/2 baths, family room, 2 attached car garage, newly decorated, Bloomfield Hills schools. \$750 month plus deposit. Also option to purchase if desired. 457-4022

404 Houses For Rent

NORTH OAK PARK 4 bedroom colonial house, 2 1/2 baths, paved family room, modern kitchen with appliances, central air, carpeted, hard wood floors, centrally carpeted, \$450 per month. Call Lincoln Park Apartments 424-9922

406 Furnished Houses For Rent

FARMINGTON GRAND RIVER 8 Mile One bedroom, also mobile home Bachelor or couple about 50 No pets. References required. 474-9535

412 Townhouses-Condos

AVAILABLE 12 Mile-Telegraph Special Discount To new residents of \$100 per month for 2 months on a 12 month lease. We pay all HEAT BILLS. Offer good on last 2 units thru July 31, 1980

412 Townhouses-Condos

TWO BEDROOM condo, Troy, Northfield Hills, \$490 monthly plus security. Fully furnished cottage on water, excellent fishing, swimming lake, tennis, horseback riding nearby. Boat dockage available. 879-1361

416 Vacation Rentals

ELIZABETH LAKE near Kreego harbor. Small cabins for rent \$90 weekly. Boat dockage available. 535-9149

420 Rooms For Rent

REDFORD AREA Room with privileges or room, board and laundry for elderly. 535-9149

422 Commercial & Industrial For Rent

AVAILABLE NOW IN PLYMOUTH 1.6, 2.75 & 27.5 Up to 9000 sq ft of manufacturing and warehouse space. Prime industrial location. Rent far below market rate. 459-1000

432 Living Quarters To Share

ABANDON YOUR HUNT SHARE - A - HOME PROFESSIONAL SERVICE SINCE 1976

404 Houses For Rent

BIRMINGHAM, 5 bedroom, 2 1/2 baths, family room, 2 attached car garage, newly decorated, Bloomfield Hills schools. \$750 month plus deposit. Also option to purchase if desired. 457-4022

404 Houses For Rent

NORTH OAK PARK 4 bedroom colonial house, 2 1/2 baths, paved family room, modern kitchen with appliances, central air, carpeted, hard wood floors, centrally carpeted, \$450 per month. Call Lincoln Park Apartments 424-9922

406 Furnished Houses For Rent

FARMINGTON GRAND RIVER 8 Mile One bedroom, also mobile home Bachelor or couple about 50 No pets. References required. 474-9535

412 Townhouses-Condos

AVAILABLE 12 Mile-Telegraph Special Discount To new residents of \$100 per month for 2 months on a 12 month lease. We pay all HEAT BILLS. Offer good on last 2 units thru July 31, 1980

412 Townhouses-Condos

TWO BEDROOM condo, Troy, Northfield Hills, \$490 monthly plus security. Fully furnished cottage on water, excellent fishing, swimming lake, tennis, horseback riding nearby. Boat dockage available. 879-1361

416 Vacation Rentals

ELIZABETH LAKE near Kreego harbor. Small cabins for rent \$90 weekly. Boat dockage available. 535-9149

420 Rooms For Rent

REDFORD AREA Room with privileges or room, board and laundry for elderly. 535-9149

422 Commercial & Industrial For Rent

AVAILABLE NOW IN PLYMOUTH 1.6, 2.75 & 27.5 Up to 9000 sq ft of manufacturing and warehouse space. Prime industrial location. Rent far below market rate. 459-1000

432 Living Quarters To Share

ABANDON YOUR HUNT SHARE - A - HOME PROFESSIONAL SERVICE SINCE 1976

404 Houses For Rent

BIRMINGHAM, 5 bedroom, 2 1/2 baths, family room, 2 attached car garage, newly decorated, Bloomfield Hills schools. \$750 month plus deposit. Also option to purchase if desired. 457-4022

404 Houses For Rent

NORTH OAK PARK 4 bedroom colonial house, 2 1/2 baths, paved family room, modern kitchen with appliances, central air, carpeted, hard wood floors, centrally carpeted, \$450 per month. Call Lincoln Park Apartments 424-9922

406 Furnished Houses For Rent

FARMINGTON GRAND RIVER 8 Mile One bedroom, also mobile home Bachelor or couple about 50 No pets. References required. 474-9535

412 Townhouses-Condos

AVAILABLE 12 Mile-Telegraph Special Discount To new residents of \$100 per month for 2 months on a 12 month lease. We pay all HEAT BILLS. Offer good on last 2 units thru July 31, 1980

412 Townhouses-Condos

TWO BEDROOM condo, Troy, Northfield Hills, \$490 monthly plus security. Fully furnished cottage on water, excellent fishing, swimming lake, tennis, horseback riding nearby. Boat dockage available. 879-1361

416 Vacation Rentals

ELIZABETH LAKE near Kreego harbor. Small cabins for rent \$90 weekly. Boat dockage available. 535-9149

420 Rooms For Rent

REDFORD AREA Room with privileges or room, board and laundry for elderly. 535-9149

422 Commercial & Industrial For Rent

AVAILABLE NOW IN PLYMOUTH 1.6, 2.75 & 27.5 Up to 9000 sq ft of manufacturing and warehouse space. Prime industrial location. Rent far below market rate. 459-1000

432 Living Quarters To Share

ABANDON YOUR HUNT SHARE - A - HOME PROFESSIONAL SERVICE SINCE 1976

404 Houses For Rent

BIRMINGHAM, 5 bedroom, 2 1/2 baths, family room, 2 attached car garage, newly decorated, Bloomfield Hills schools. \$750 month plus deposit. Also option to purchase if desired. 457-4022

404 Houses For Rent

NORTH OAK PARK 4 bedroom colonial house, 2 1/2 baths, paved family room, modern kitchen with appliances, central air, carpeted, hard wood floors, centrally carpeted, \$450 per month. Call Lincoln Park Apartments 424-9922

406 Furnished Houses For Rent

FARMINGTON GRAND RIVER 8 Mile One bedroom, also mobile home Bachelor or couple about 50 No pets. References required. 474-9535

412 Townhouses-Condos

AVAILABLE 12 Mile-Telegraph Special Discount To new residents of \$100 per month for 2 months on a 12 month lease. We pay all HEAT BILLS. Offer good on last 2 units thru July 31, 1980

412 Townhouses-Condos

TWO BEDROOM condo, Troy, Northfield Hills, \$490 monthly plus security. Fully furnished cottage on water, excellent fishing, swimming lake, tennis, horseback riding nearby. Boat dockage available. 879-1361

416 Vacation Rentals

ELIZABETH LAKE near Kreego harbor. Small cabins for rent \$90 weekly. Boat dockage available. 535-9149

420 Rooms For Rent

REDFORD AREA Room with privileges or room, board and laundry for elderly. 535-9149

422 Commercial & Industrial For Rent

AVAILABLE NOW IN PLYMOUTH 1.6, 2.75 & 27.5 Up to 9000 sq ft of manufacturing and warehouse space. Prime industrial location. Rent far below market rate. 459-1000

432 Living Quarters To Share

ABANDON YOUR HUNT SHARE - A - HOME PROFESSIONAL SERVICE SINCE 1976

404 Houses For Rent

BIRMINGHAM, 5 bedroom, 2 1/2 baths, family room, 2 attached car garage, newly decorated, Bloomfield Hills schools. \$750 month plus deposit. Also option to purchase if desired. 457-4022

404 Houses For Rent

NORTH OAK PARK 4 bedroom colonial house, 2 1/2 baths, paved family room, modern kitchen with appliances, central air, carpeted, hard wood floors, centrally carpeted, \$450 per month. Call Lincoln Park Apartments 424-9922

406 Furnished Houses For Rent

FARMINGTON GRAND RIVER 8 Mile One bedroom, also mobile home Bachelor or couple about 50 No pets. References required. 474-9535

412 Townhouses-Condos

AVAILABLE 12 Mile-Telegraph Special Discount To new residents of \$100 per month for 2 months on a 12 month lease. We pay all HEAT BILLS. Offer good on last 2 units thru July 31, 1980

412 Townhouses-Condos

TWO BEDROOM condo, Troy, Northfield Hills, \$490 monthly plus security. Fully furnished cottage on water, excellent fishing, swimming lake, tennis, horseback riding nearby. Boat dockage available. 879-1361

416 Vacation Rentals

ELIZABETH LAKE near Kreego harbor. Small cabins for rent \$90 weekly. Boat dockage available. 535-9149

420 Rooms For Rent

REDFORD AREA Room with privileges or room, board and laundry for elderly. 535-9149

422 Commercial & Industrial For Rent

AVAILABLE NOW IN PLYMOUTH 1.6, 2.75 & 27.5 Up to 9000 sq ft of manufacturing and warehouse space. Prime industrial location. Rent far below market rate. 459-1000

432 Living Quarters To Share

ABANDON YOUR HUNT SHARE - A - HOME PROFESSIONAL SERVICE SINCE 1976

404 Houses For Rent

BIRMINGHAM, 5 bedroom, 2 1/2 baths, family room, 2 attached car garage, newly decorated, Bloomfield Hills schools. \$750 month plus deposit. Also option to purchase if desired. 457-4022

404 Houses For Rent

NORTH OAK PARK 4 bedroom colonial house, 2 1/2 baths, paved family room, modern kitchen with appliances, central air, carpeted, hard wood floors, centrally carpeted, \$450 per month. Call Lincoln Park Apartments 424-9922

406 Furnished Houses For Rent

FARMINGTON GRAND RIVER 8 Mile One bedroom, also mobile home Bachelor or couple about 50 No pets. References required. 474-9535

412 Townhouses-Condos

AVAILABLE 12 Mile-Telegraph Special Discount To new residents of \$100 per month for 2 months on a 12 month lease. We pay all HEAT BILLS. Offer good on last 2 units thru July 31, 1980

412 Townhouses-Condos

TWO BEDROOM condo, Troy, Northfield Hills, \$490 monthly plus security. Fully furnished cottage on water, excellent fishing, swimming lake, tennis, horseback riding nearby. Boat dockage available. 879-1361

416 Vacation Rentals

ELIZABETH LAKE near Kreego harbor. Small cabins for rent \$90 weekly. Boat dockage available. 535-9149

420 Rooms For Rent

REDFORD AREA Room with privileges or room, board and laundry for elderly. 535-9149

422 Commercial & Industrial For Rent

AVAILABLE NOW IN PLYMOUTH 1.6, 2.75 & 27.5 Up to 9000 sq ft of manufacturing and warehouse space. Prime industrial location. Rent far below market rate. 459-1000

432 Living Quarters To Share

ABANDON YOUR HUNT SHARE - A - HOME PROFESSIONAL SERVICE SINCE 1976

404 Houses For Rent

BIRMINGHAM, 5 bedroom, 2 1/2 baths, family room, 2 attached car garage, newly decorated, Bloomfield Hills schools. \$750 month plus deposit. Also option to purchase if desired. 457-4022

404 Houses For Rent

NORTH OAK PARK 4 bedroom colonial house, 2 1/2 baths, paved family room, modern kitchen with appliances, central air, carpeted, hard wood floors, centrally carpeted, \$450 per month. Call Lincoln Park Apartments 424-9922

406 Furnished Houses For Rent

FARMINGTON GRAND RIVER 8 Mile One bedroom, also mobile home Bachelor or couple about 50 No pets. References required. 474-9535

412 Townhouses-Condos

AVAILABLE 12 Mile-Telegraph Special Discount To new residents of \$100 per month for 2 months on a 12 month lease. We pay all HEAT BILLS. Offer good on last 2 units thru July 31, 1980

412 Townhouses-Condos

TWO BEDROOM condo, Troy, Northfield Hills, \$490 monthly plus security. Fully furnished cottage on water, excellent fishing, swimming lake, tennis, horseback riding nearby. Boat dockage available. 879-1361

416 Vacation Rentals

ELIZABETH LAKE near Kreego harbor. Small cabins for rent \$90 weekly. Boat dockage available. 535-9149

420 Rooms For Rent

REDFORD AREA Room with privileges or room, board and laundry for elderly. 535-9149

422 Commercial & Industrial For Rent

AVAILABLE NOW IN PLYMOUTH 1.6, 2.75 & 27.5 Up to 9000 sq ft of manufacturing and warehouse space. Prime industrial location. Rent far below market rate. 459-1000

432 Living Quarters To Share

ABANDON YOUR HUNT SHARE - A - HOME PROFESSIONAL SERVICE SINCE 1976