

---

STUDIES IN ANNONACEAE  
XXXVI. THE *DUGUETIA*  
ALLIANCE: WHERE THE  
WAYS PART<sup>1</sup>

---

Lars W. Chatrou,<sup>2</sup> Jifke Koek-Noorman,<sup>2</sup>  
and Paul J. M. Maas<sup>2</sup>

ABSTRACT

Results of a cladistic analysis of morphological and anatomical data of the *Duguetia* alliance (Annonaceae) are presented. Several novel characters, or characters so far not incorporated into phylogenetic analyses, are used. Parsimony analysis resulted in two strongly supported clades: a *Fusaea* clade, comprising *Fusaea*, *Duckeanthus*, *Letestudoxa*, and *Pseudartabotrys*, and a *Duguetia* clade, comprising all Neotropical and African species of *Duguetia*. Support for the past distinction of *Pachypodanthium* from *Duguetia* appears to be absent. Characters used to resolve relationships between and within the two clades are difficult to polarize by outgroup comparison. It is demonstrated that the critical reassessment of classical morphological characters, and the search for new ones, may well advance phylogenetic resolution within Annonaceae.

*Key words:* Annonaceae, cladistics, *Duckeanthus*, *Duguetia*, *Fusaea*, *Letestudoxa*, morphology, *Pachypodanthium*, *Pseudartabotrys*.

---

The classification of the Annonaceae presents workers on this family with a Herculean challenge. Early classifications of the family, as in Hooker and Thomson (1855), emphasize identification and only incidentally reflect phylogeny. This also applies to a more recent classification (Hutchinson, 1964). However, at higher, tribal levels, these two classifications have little in common. To date, the classification by Fries (1959) resolves most subgroups. Exclusively on the basis of inflorescence and floral characters, he distinguished two subfamilies, three tribes, and 14 informal genus groupings. The composition of many of these genus groups has been amended after phenetic analyses of flower and fruit morphology (van Heusden, 1992; van Setten & Koek-Noorman, 1992; Koek-Noorman et al., 1997), and phylogenetic analyses based on gross morphological and palynological data (Doyle & Le Thomas, 1994, 1996, 1997).

One of Fries's genus groups is the *Duguetia* alliance, comprising West African and tropical American genera. The composition of this alliance remained untouched to date except for the exclusion of *Malmea* and the inclusion of the monotypic genus *Pseudartabotrys* (van Setten & Koek-Noorman,

1992). Characteristic features of the genera belonging to this alliance include valvate sepals, imbricate petals, one basal ovule, and the presence of a rudimentary aril. Most distinctive for the alliance is the presence of pseudosyncarpous fruits. These are aggregates of astipitate carpels, which become fused with one another and/or adnate to the receptacle. Genera usually considered to fit into the *Duguetia* alliance are the Neotropical genera *Duckeanthus* (1 sp.), *Duguetia* (95 spp.), and *Fusaea* (2 spp.), together with *Letestudoxa* (3 spp.), *Pachypodanthium* (4 spp.), and *Pseudartabotrys* (1 sp.) from West Africa (van Setten & Koek-Noorman, 1992; Le Thomas et al., 1994; Koek-Noorman et al., 1997). Van Heusden (1992) dissentingly placed *Duguetia* and *Pachypodanthium* in one informal group, separate from *Duckeanthus*, *Fusaea*, *Letestudoxa*, and *Pseudartabotrys* (plus *Afroguatteria*, *Enicosanthellum*, and *Disepalum*) in another.

Thus, the majority opinion on the circumscription of the *Duguetia* alliance seems to prevail. Yet closer examination reveals some problems. Recent cladistic analyses (Doyle & Le Thomas, 1994, 1995, 1996, 1997; Doyle et al., 2000) array *Duguetia*, *Pachypodanthium*, *Letestudoxa*, *Fusaea*,

---

<sup>1</sup> The authors thank Jan van Veldhuizen, Jos van der Maesen, and Jan Wieringa of the National Herbarium of the Netherlands, Wageningen Agricultural University branch, for providing herbarium collections, spirit material, and photographs of African species, Heimo Rainer for information on *Annona*, Jan Maas for technical assistance, Hendrik Rypkema and Frouke Gerards for artwork, Henk 't Hart and Peter van Welzen for support and discussion during the cladistic analyses, and Annick Le Thomas and an anonymous reviewer for critical comments on the manuscript. Financial support was provided by the Netherlands Organization for Scientific Research (NWO; grant no. 805-40.201) to the first author, which is gratefully acknowledged.

<sup>2</sup> National Herbarium of the Netherlands, Utrecht University branch, Heidelberglaan 2, 3584 CS Utrecht, the Netherlands.

and *Duckeanthus* in one clade, linked to the clade of the "xylopioids." *Pseudartabotrys* was not included in these analyses.

Pseudosyncarpy, which otherwise only occurs in the *Annona* group, is an obvious synapomorphy for this "*Duguetia* clade." During pseudosyncarpous fruit development the postgenital aggregating of the carpels can occur through two processes, viz. the lateral fusion of carpel walls, and the inclusion of the very basal parts of the carpels into the fruiting receptacle. The former case has been extensively documented for the genera *Annona* and *Rollinia* by Briechle-Mäck (1994). The fusion of carpels starts with dovetailing of the epidermal cells of adjacent carpels, and ends with complete fusion. The fruiting receptacle does not contribute to the aggregating of the fruit. A similar fruit development has been described for *Fusaea* (Chatrou & He, 1999). The inclusion of the very basal parts of the carpels into the fruiting receptacle (see Svoma, 1998) originates from acropetal development of the receptacle after flowering has been completed. This type of aggregating of the fruit is present in all species of *Duguetia*, whereas the degree of lateral fusion of the carpels varies from completely free to completely fused among the species of this genus. Thus, both origins of pseudosyncarpy occur within the *Duguetia* alliance and can be traced when closely inspecting fruit morphology. Pseudosyncarpy should therefore be considered as a non-homologous similarity. However, the fruit type can be incorporated into analyses in a more straightforward way by unravelling it ontogenetically (Patterson, 1982). In this analysis we will consider the differential origins of pseudosyncarpy, separating it into two morphological characters (see Data and Analyses).

A family-wide phenetic analysis based on flower and fruit morphology resulted in inclusion of *Duckeanthus*, *Letestudoxa*, *Pseudartabotrys*, *Fusaea*, and *Pachypodanthium* in one cluster (Koek-Noorman et al., 1997). *Duguetia* appeared in another cluster, together with *Guatteria* and the *Annona* group. Nevertheless, the overall similarity between all genera, including *Duguetia*, was perceived so strongly by the authors that the signal appearing from the phenogram was ignored, and all genera were grouped together in a tentative scheme of genus groups. In the same paper, Koek-Noorman et al. (1997) concluded that some of the principal characters used by Fries (1959) for the distinction of genus groups, viz. sepal and petal aestivation, barely contribute to their phenetic clustering.

The following paradox thus emerges: a genus group, or clade, has long been recognized intuitively

but is weakly supported by morphological evidence. Schatz and Le Thomas (1993) stated that confusing phylogenetic patterns based on macro-morphological character distribution within Annonaceae have been clarified during the past two decades by new palynological and karyological evidence. In spite of its general validity, this statement cannot be applied to the *Duguetia* alliance. Karyological evidence is too scattered to be unequivocal (Doyle & Le Thomas, 1996). Palynological data reveal too many autapomorphies among the genera of this alliance to be illuminating. Based wholly on palynological data, Walker (1971) even erected the informal *Fusaea* subfamily, accommodating *Fusaea* and *Duckeanthus*, but placed *Duguetia* in another subfamily. Walker's data were reinterpreted by Le Thomas (1980–1981) and Le Thomas et al. (1994). However, Le Thomas et al. (1994) did not clarify the phylogeny of the *Duguetia* alliance with pollen ultrastructural data, but conversely discussed the implications of their resulting phylogenies for the evolution of pollen morphology.

Doyle and Le Thomas (1996) stated that given the high level of morphological homoplasy in Annonaceae, only molecular analysis might be able to resolve higher-level relationships. The *Duguetia* alliance was addressed by van Zuilén (1996) with her cladistic analysis of *trnL-F* sequences, combined with morphological characters, favoring the inclusion of *Duguetia*, *Fusaea*, *Pachypodanthium*, and *Pseudartabotrys* as one clade. *Duckeanthus* and *Letestudoxa* were not included in her analysis.

Except for most seed characters, many of the morphological characters used in the above-mentioned analyses still are conventional characters in a Friesian vein (e.g., Fries, 1934, 1959), which have been subject to little recent critical revision. Moreover, regarding the reticulate nature of character expression in Annonaceae, the taxonomic level at which a phylogenetic analysis is performed determines the character choice. Contrasting with a family-wide phylogenetic analysis, an analysis at the tribal or genus group level requires different data matrices informative only for the particular group examined, as was elegantly shown by Johnson and Murray (1995) in their analysis of the tribe Bocageae.

In this paper we address the phylogeny of the *Duguetia* alliance sensu Koek-Noorman et al. (1997) and Le Thomas et al. (1994), by conducting a cladistic analysis based on leaf, flower, fruit, and seed characters, many of which have not been used in cladistic analyses of Annonaceae before now. We provide the rationale for the recent submersion of

Table 1. Data matrix with taxa, characters, and character states used. The species abbreviations, as used in Figure 2, are in parentheses. \*: African species of *Duguetia*. ?: character state unknown.

		1										2													
		1	2	3	4	5	6	7	8	9	10	11	12	13	14	15	16	17	18	19	20	21	22	23	24
<i>Annona sericea</i> Dunal	(Annsr)	0	0	0	0	0	0	0	0	0	0	0	0	0	0	0	0	0	0	0	0	0	0	0	0
<i>Duckeanthus grandiflorus</i> R. E. Fr.	(Ducgra)	0	0	0	0	1	0	2	0	0	0	0	1	0	0	1	0	2	0	1	0	0	1	1	0
<i>Duguetia argentea</i> (R. E. Fr.) R. E. Fr.	(Dugarg)	0	2	0	0	0	1	0	0	0	0	2	0	0	0	0	0	0	0	0	0	0	0	0	1
<i>Duguetia asterotricha</i> (Diels) R. E. Fr.	(Dugast)	0	1	0	0	0	0	0	0	0	1	2	0	0	2	0	?	0	0	0	0	1	1	1	0
<i>Duguetia barteri</i> (Benth.) Chatrou*	(Dugbar)	0	1	1	0	0	1	0	0	2	1	2	0	0	0	0	1	0	1	0	0	0	1	1	0
<i>Duguetia confinis</i> (Engl. & Diels) Chatrou*	(Dugcon)	0	1	1	0	0	1	0	0	2	1	2	0	0	0	0	1	0	1	0	0	0	1	1	0
<i>Duguetia dilabens</i> Chatrou & Repetur*	(Dugdil)	0	1	1	0	0	1	0	0	2	0	0	0	0	1	0	1	0	0	0	1	1	0	1	0
<i>Duguetia furfuracea</i> (A.St.-Hil.) Benth. & Hook.f.	(Dugfur)	0	2	0	0	0	1	0	0	0	2	0	2	0	0	1	0	0	0	0	0	1	1	0	0
<i>Duguetia inconspicua</i> Sagot	(Duginc)	0	1	0	0	0	0	0	0	2	0	0	0	0	1	0	1	0	0	0	1	1	0	1	0
<i>Duguetia lanceolata</i> A. St.-Hil.	(Duglan)	0	2	0	0	0	1	0	0	0	2	0	2	0	0	1	0	0	0	0	1	1	0	0	0
<i>Duguetia neglecta</i> Sandw.	(Dugneg)	0	1	0	0	0	0	0	0	1	0	0	0	0	0	0	0	0	0	0	0	0	0	1	1
<i>Duguetia quitarensis</i> Benth.	(Dugqui)	0	2	0	0	0	1	0	0	0	2	0	0	0	0	1	0	0	0	0	0	1	1	0	0
<i>Duguetia riberensis</i> Aristeg. ex Maas & Boon	(Dugrib)	0	1	1	0	0	1	0	0	1	0	2	0	0	0	?	0	0	0	0	0	1	1	0	0
<i>Duguetia riparia</i> Huber	(Dugrip)	0	1	0	0	0	0	0	0	1	2	0	0	0	0	0	0	0	0	0	0	1	1	0	0
<i>Duguetia spixiana</i> Mart.	(Dugspi)	0	2	0	0	0	1	0	0	2	1	0	2	0	0	0	0	0	0	0	0	1	1	0	0
<i>Duguetia staudtii</i> (Engl. & Diels) Chatrou*	(Dugsta)	0	1	1	0	0	0	0	0	2	0	0	0	0	1	0	1	0	0	0	1	1	0	0	0
<i>Duguetia uniflora</i> (DC. ex Dunal) Mart.	(Duguni)	0	1	0	0	0	0	0	0	2	0	0	0	0	1	1	0	0	0	0	1	1	0	0	0
<i>Fusaea longifolia</i> (Aubl.) Saff.	(Fuslon)	0	0	0	1	0	1	0	1	0	1	2	1	0	1	1	0	2	0	1	1	0	0	0	1
<i>Fusaea peruviana</i> R. E. Fr.	(Fusper)	0	0	0	1	0	1	0	1	0	1	2	1	0	1	1	0	2	0	1	1	0	0	0	1
<i>Letestudoxa bella</i> Pellegr.	(Letbel)	1	0	0	1	1	0	0	1	1	1	2	1	1	2	0	1	0	0	0	1	1	0	0	1
<i>Letestudoxa glabrifolia</i> Chatrou & Repetur	(Letgla)	1	0	0	1	0	0	1	1	?	2	1	?	2	0	1	0	0	0	1	1	0	0	0	1
<i>Letestudoxa lanuginosa</i> Le Thomas	(Letlan)	1	0	0	1	0	0	1	1	2	2	1	?	2	0	1	0	?	?	?	?	?	?	?	?
<i>Pseudartabotrys letestui</i> Pellegr.	(Pselet)	1	0	0	0	0	0	1	1	1	0	1	1	2	0	1	0	1	0	1	0	0	1	0	0

1—habit; 0 = tree/treelet, 1 = liana

2—trichomes; 0 = simple, 1 = stellate, 2 = lepidote (+ stellate)

3—leaf shape asymmetric; 0 = no, 1 = yes

4—secondary veins on upper side of leaf; 0 = flat to raised, 1 = impressed

5—secondary veins joining to form marginal vein; 0 = no, 1 = yes

6—mesophyll type; 0 = dorsiventral, 1 = isobilateral

7—histology of primary vein; 0 = phloem and/or sclerenchyma surrounding xylem body, 1 = phloem and/or sclerenchyma surrounding and intruding xylem body, 2 = phloem only abaxially accompanying xylem

8—curly trichomes; 0 = absent, 1 = present

9—inflorescence position: terminal on short axillary shoot; 0 = never, 1 = sometimes, 2 = always (ordered)

10—inflorescence: abnormal displacement of prophyll; 0 = absent, 1 = present

11—bracts; 0 = non-cucullate, scale-like, 1 = non-cucullate, foliaceous, 2 = cucullate

12—pedicel abruptly and distinctly widening into flowering receptacle; 0 = no, 1 = yes

13—flower color (in vivo); 0 = white to cream, 1 = yellow to orange, 2 = pink to red

14—fusion sepals; 0 = free or basally connate, 1 = subentirely connate, rupturing longitudinally, 2 = entirely connate, rupturing irregularly

15—petals velutinous; 0 = no, 1 = yes

16—stamen color (in vivo); 0 = white-cream-yellow, 1 = pink to red

17—stamens sclerified; 0 = no, 1 = only on adaxial side, 2 = on both sides

18—position of anther thecae; 0 = extrorse, 1 = latrorse

19—style; 0 = absent, 1 = present

20—styles coherent by interlocking papillae; 0 = no, 1 = yes

21—sepals persistent in fruit; 0 = no, 1 = yes

22—basal carpels fused with fruiting receptacle; 0 = no, 1 = yes

23—fruiting receptacle protruding between carpels; 0 = no, 1 = yes

24—direction of aril fibers; 0 = toward distal end of seed, 1 = toward proximal end of seed

*Pachypodanthium* into the synonymy of *Duguetia* (Chatrou, 1998). Species formerly known as *Pachypodanthium* will hereafter be referred to as “African species of *Duguetia*.” A biogeographical question comprises whether the break-up of West Gondwana was a vicariance event for this subgroup

as well as for most Annonaceae (Schatz & Le Thomas, 1993).

#### DATA AND ANALYSES

The data matrix includes 23 taxa and 24 characters (Table 1). All species of *Duckeanthus*, *Fu-*

*saea*, *Letestudoxa*, and *Pseudartabotrys* are included in the analysis. (For vouchers, see Appendix 1.) All 4 African species, and 11 Neotropical species of *Duguetia* are selected out of ca. 95 that constitute the genus. *Annona sericea* is included as outgroup taxon for two reasons. First, *Annona* is included in a clade that is directly linked to the pseudosyncarpous clade on the basis of sequence data (van Zuilén, 1996). Furthermore, of the genera that appear close to the pseudosyncarps in van Zuilén's analysis, *Annona* is the only genus with pseudosyncarpous fruits, and (often) with seeds provided with a rudimentary aril. Therefore, the scoring of characters 22–24 for the outgroup is enabled. The character set has been designed to incorporate independently evolving morphological and anatomical data from different plant parts. It comprises 17 binary characters and 7 three-state characters. Of the latter characters, only character 9 is quantitatively ordered, scoring for the relative abundance of the particular inflorescence position within a species. Although our objectives pertain to genera, the characters are scored at the species level. This allows the scoring of several characters with inconsistent character states within a genus. Characters 3, 6, 8, 9, 10, 11, 12, 13, 14, 16, and 18 are heterogeneous within a particular genus, while homogeneous within another. *Duguetia* possesses multiple states for all of these characters except for trichome character 8, while one of the other, non-monotypic genera is scored uniformly. Scoring at the species level also permits us to address the question of the relationship between the Neotropical and African species of *Duguetia*. Bootstrap values of a previous phylogenetic analysis of *Duguetia* inspire little confidence in the clades found, nor in most of the sections of *Duguetia* as recognized by Fries (van Zuilén et al., 1995). Therefore, our choice of the 11 species for our analysis is such that they display the phenetic variation within the genus well. We decided to include *Letestudoxa lanuginosa* in the analysis, despite the fact that its fruits are unknown, and therefore characters 21–24 could not be scored. Inclusion may possibly allow more insight into the evolution of flower color (character 13), as *L. lanuginosa* has its flower color in common with only two species of *Duguetia* (*D. furfuracea* and *D. lanceolata*). The missing values for characters 21–24 do not present any problem for the analysis, as they are simply treated as uninformative.

Some of the characters in our analysis are straightforward morphological (or anatomical) ones. Other characters have hardly been documented, or

are presented for the first time, with the following explanations.

Character 7: histology of the primary vein. Details hereon can be found in van Setten and Koek-Noorman (1986). In their survey of leaf anatomy of Annonaceae, *Duckeanthus* has not been taken into account. We sectioned leaf parts of *D. grandiflorus* according to the same methods as described in van Setten and Koek-Noorman (1986). The histology of the primary vein of *Duckeanthus* shows a pattern that is hitherto unknown in Annonaceae. The phloem only abaxially accompanies the xylem (Fig. 1A). This pattern is an autapomorphy of *Duckeanthus*, and we scored it as a separate character state.

Character 8: curly trichomes. Curly trichomes have been described for *Fusaea* (Chatrou & He, 1999) and *Letestudoxa* (Chatrou, 1998). In both genera these trichomes occur on the lower side of the leaves, on the petioles, and on the young twigs. In *Letestudoxa* they occur on the outer side of the calyx as well. Besides curly trichomes, normal straight trichomes occur as well in both genera.

Character 9: position of inflorescence. Two African species of *Duguetia* exclusively have terminal inflorescences on reduced axillary leafy shoots. Le Thomas (1969) described them as axillary for *D. barteri*. Two Neotropical species of *Duguetia* (*D. neglecta* and *D. riberensis*) exhibit the same position of the inflorescence, though not in all cases. Hence, the latter two species have been scored as 1. The position of the inflorescences in other *Duguetia* species is terminal on leafy twigs, and never on reduced axillary leafy shoots.

Character 10: inflorescence, abnormal displacement of prophyll. This phenomenon has been described for inflorescences of *Fusaea* (Chatrou & He, 1999), and is also present in four species of *Duguetia*. Normally subsequent fertile prophylls alternate at angles of 180°. In *Fusaea*, *D. asterotricha*, *D. barteri*, *D. confinis*, and *D. riparia* the prophylls alternate at angles of ca. 90° only.

Character 11: shape of bracts. Cucullate bracts have been documented for *Fusaea* by Chatrou and He (1999), and have been found in all species of *Duguetia*, except for *D. neglecta*, which has foliaceous bracts.

Character 17: sclerified stamens. Van Heusden (1992) mentioned the occurrence of indurate (more or less lignified) stamens in *Duckeanthus*, *Fusaea*, *Letestudoxa*, and *Pseudartabotrys*. We made medial cross sections for at least 10 stamens per species, staining with Astra-blue and Safranin, to check for the occurrence of sclerenchyma. Two basic patterns were found: (1) sclerenchyma is either absent; or (2) sclerenchyma is present on both the entire inner

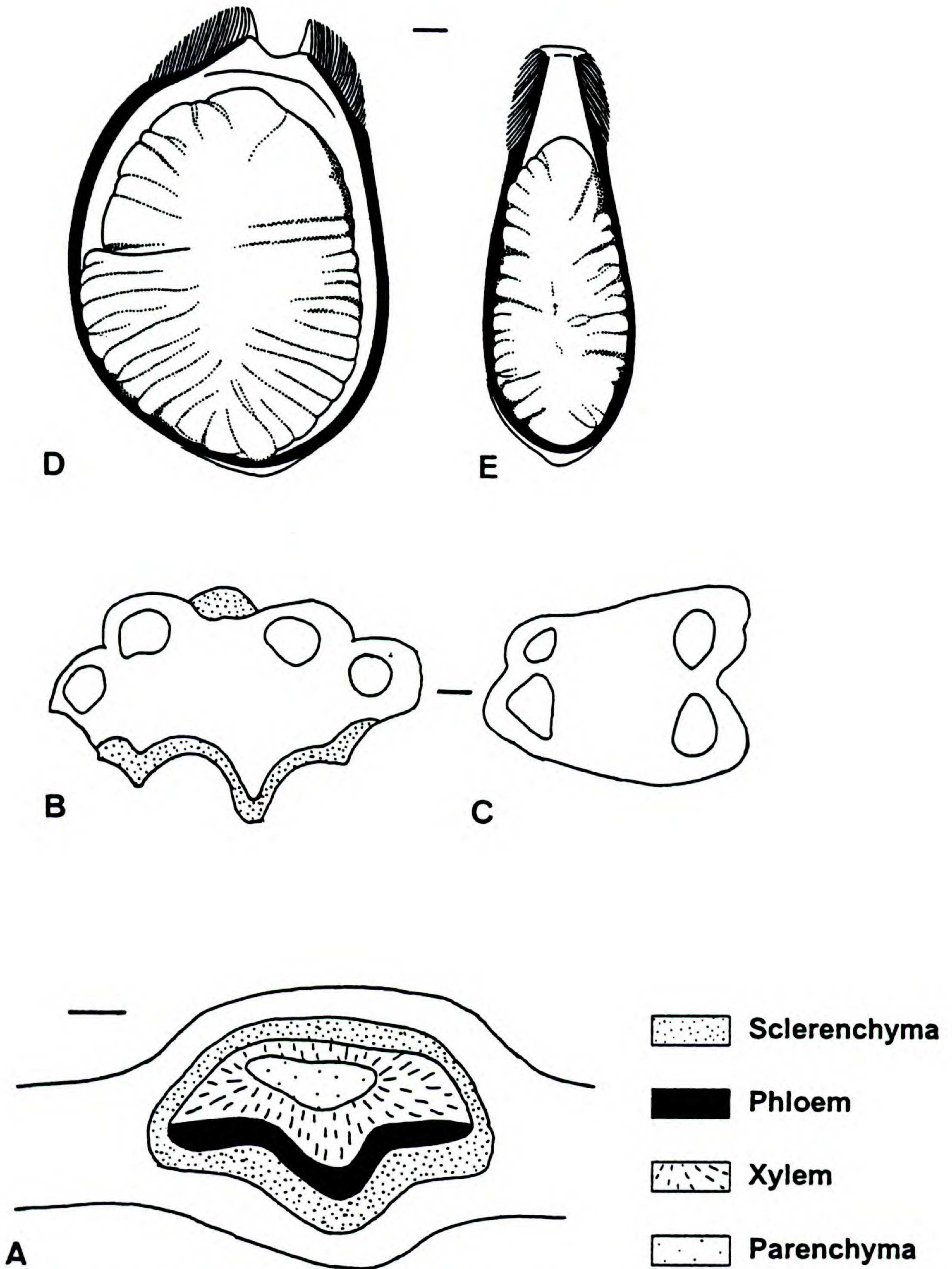

Figure 1. —A. Schematic drawing of transverse section through primary vein of *Duckeanthus grandiflorus*. B, C. Cross sections through stamens. —B. *Fusaea longifolia*, showing sclerified tissue (dotted region) and extrorse locules. —C. *Duguetia staudtii*, showing latrorse locules and no sclerification. D, E. Seeds transversely sectioned through raphe, showing direction of aril fibers. —D. Directed toward proximal end of seed: *Fusaea longifolia*. —E. Directed toward distal end of seed: *Duguetia confinis*. Scale bars: A–C = 0.1 mm; D, E = 1 mm.

side, as well as on the outer side between the thecae (Fig. 1B, C). Only *Duguetia uniflora* showed an intermediate pattern, with sclerenchyma found only on the inner side of the stamen, and absent between the thecae.

Characters 19 and 20: styles. For Annonaceae, the presence of a style is often difficult to judge. *Fusaea* has clearly distinct ovaries, styles, and stigmas. Its transition between ovary and style is indicated by a constriction, and by differences in epidermal outgrowths, and in shape in transverse section. The stigma can be discerned from the style by differences in color and epidermal outgrowths (Chatrou & He, 1999). The same pattern occurs in *Duckeanthus*, *Letestudoxa*, and *Pseudartabotrys*. As in *Fusaea*, the styles of *Duckeanthus* interlock by means of papillae. In those species of *Duguetia* examined, a clear distinction can be seen between the ovary and the apical part of the carpel, but subsequent transitions are absent. Therefore a style is considered to be absent in these genera, in spite of their presumed presence according to van Heusden (1992) and Doyle and Le Thomas (1996).

Characters 22 and 23: fruit type. Among fruits of different species of *Duguetia*, different degrees of fusion of the carpels occur. However, in all species the fruiting receptacle protrudes between the carpels by acropetal growth (Svoma, pers. comm. 1996). In fruits with a low degree of carpellary fusion this is very noticeable, especially when dried. Here, the surface of the receptacle shows shallow concavities in which the carpels are loosely positioned. Yet even in fruits with a high degree of carpellary fusion (e.g., *Duguetia furfuracea*, *D. barteri*) the protrusion of the receptacle between the carpels is discernible. Fruits of *Duckeanthus* and *Letestudoxa* have free, stipeless carpels, attached to the fruiting receptacle in shallow concavities, resulting in a functional syncarp (Schatz & Le Thomas, 1993) similar to those of *Duguetia*. An important difference between fruits of *Duckeanthus* and *Letestudoxa* on the one hand, and those of *Duguetia* on the other, is the position of the basal sterile carpels. In the latter genus, these basal carpels inseparably coalesce with the fruiting receptacle and constitute a proximal collar on the fruiting receptacle. In *Duckeanthus* and *Letestudoxa*, the basal, sterile carpels contribute to the functional syncarp and readily detach from the fruiting receptacle.

Character 24: direction of aril fibers. Arillate seeds are found in all species of the *Duguetia* alliance. The aril is considered to be rudimentary (van Setten & Koek-Noorman, 1992) as it covers considerably smaller parts of the seed than seen in species of the tribe Bocageae. Among the *Dugue-*

*tia* alliance, the aril develops from the base of the testa, distinguished from the other parts of the testa by its closely packed, long parallel cells (Garwood, 1995). We found that these rudimentary arils further assort into two types. The first type has the long, parallel cells directed toward the distal end of the seed, while in the second type they are directed proximally (Fig. 1D, E).

The data were analyzed using PAUP version 3.1.1 (Swofford, 1993). Heuristic searches for most parsimonious trees were performed by random stepwise addition with 100 repetitions, the Tree-Bisection-Reconnection (TBR) branch swapping algorithm, and the MULPARS and STEEPEST DESCENT options in effect. Only minimal trees were retained, and zero-length branches were broken down with the COLLAPSE option. The use of either the DELTRAN or the ACCTRAN optimization criterion produced identical tree topologies. Bootstrapping was performed with the TBR swapping algorithm, simple addition sequence, and 250 repetitions. The relative robustness of the clades was assessed additionally by performing a decay analysis (Bremer, 1988; Donoghue et al., 1992) for all clades of the strict consensus tree. Character evolution was analyzed using MacClade 3.04 (Maddison & Maddison, 1992).

## RESULTS AND DISCUSSION

Parsimony analysis of the data matrix in Table 1 resulted in 63 shortest trees of 49 steps. All 63 trees belong to one island of trees, with each tree connected to every other tree in the island through a series of trees, and each one differing from the next by a single rearrangement of branches (Maddison, 1991). The strict consensus tree has a consistency index (CI) of 0.65 and a retention index (RI) of 0.85 (Fig. 2). Bootstrap values are indicated above the nodes for each clade of the consensus tree that is maintained after bootstrap analysis. Bootstrap values  $\geq 50$  are given. Bootstrap values  $\geq 70$  are considered to be high. Our consensus tree satisfactorily meets the conditions under which bootstrap values  $\geq 70$  correspond to a probability of  $\geq 95\%$  that the corresponding clade accurately reflects the true phylogeny (Hillis & Bull, 1993). Only the condition of internodal change of  $\leq 20\%$  is not fully met: the basal nodes with bootstrap values of 95 and 88 both have an internodal change of 25% of the characters. Decay values are indicated below the nodes. We were unable to realize a decay analysis in which trees of three steps longer were retained. The large number of trees resulting

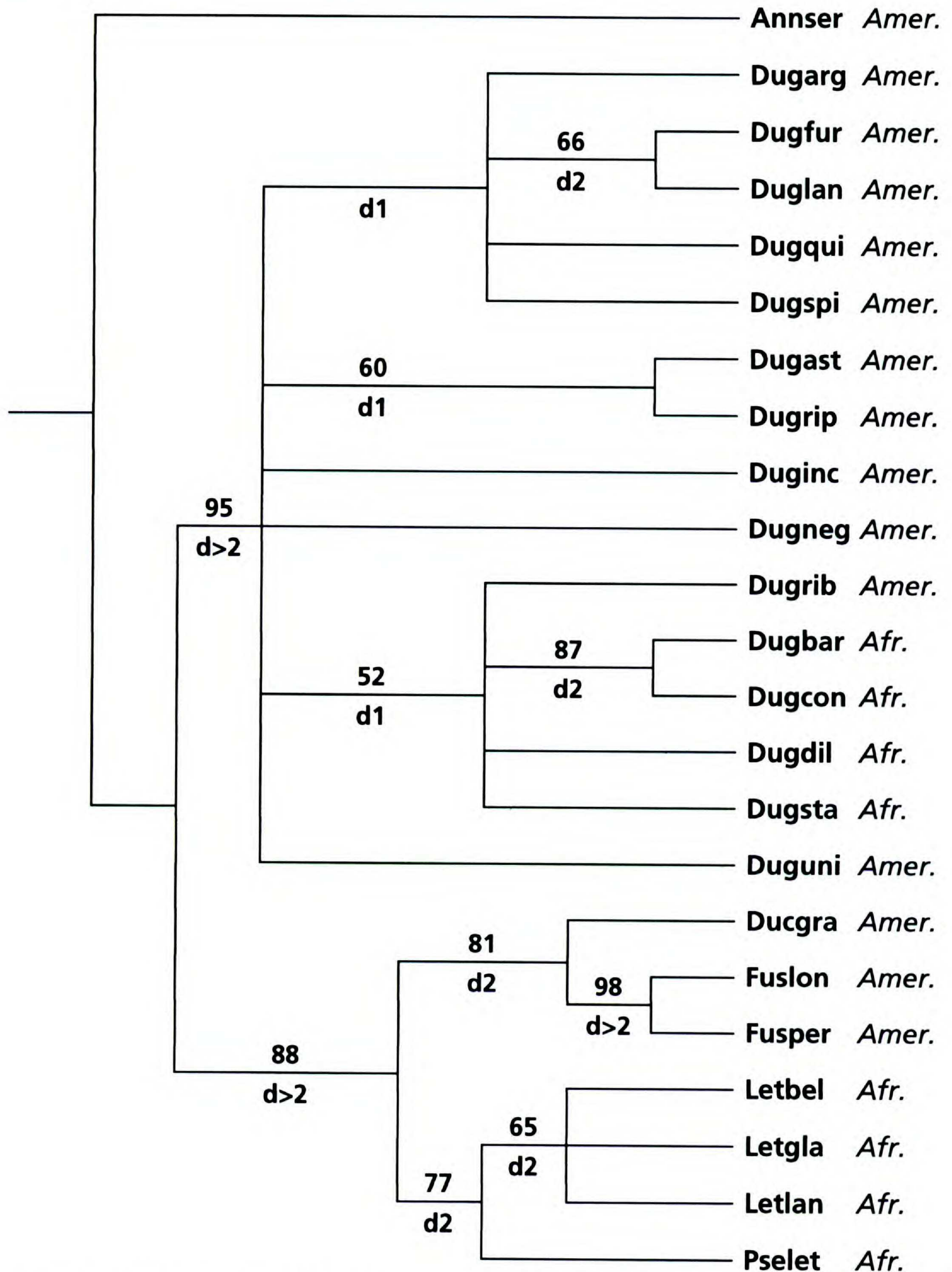

Figure 2. Strict consensus tree of 63 most parsimonious trees after analysis with outgroup rooting. Taxa are indicated with the first three letters of both generic name and epithet (see also Table 1). Bootstrap values are indicated above the nodes. Decay values are indicated below the nodes. *Amer.* and *Afr.* indicate American or African distribution of taxon.

Table 2. Synapomorphies for the combined *Duguetia-Fusaea* clade, and for the *Duguetia* clade and the *Fusaea* clade separately. The number of the character as described in Table 1 is included in parentheses.

<i>Duguetia-Fusaea</i> clade	<i>Duguetia</i> clade	<i>Fusaea</i> clade
No synapomorphies	(19) style absent	(12) pedicel abruptly and distinctly widening into
	(22) basal carpels fused with fruiting receptacle	flowering receptacle
	(23) fruiting receptacle protruding be- tween carpels	(15) petals velutinous
	(24) aril fibers directed toward distal end of seed	(17) stamens sclerified on both sides

from this search exceeded the maximum number of trees that PAUP can retain.

The high amount of synapomorphy, as expressed by the high RI, the high bootstrap values, and the highest decay values for (1) the clade formed by all species of *Duguetia* (*Duguetia* clade), and (2) the clade formed by *Duckeanthus*, *Fusaea*, *Letestudoxa*, and *Pseudartabotrys* (*Fusaea* clade), arouse high confidence in these clades. These results disapprove placement of all six genera into one clade or alliance (Doyle & Le Thomas, 1994, 1996; Koek-Noorman et al., 1997; Le Thomas et al., 1994), and support the distinction made among them by van Heusden (1992). The inclusion of *Afroguatteria*, *Disepalum*, and *Enicosanthellum* into the *Fusaea* group by van Heusden (1992), however, is contradicted by strong evidence, both from general morphology as well as from molecular evidence (Doyle & Le Thomas, 1994, 1996; Koek-Noorman et al., 1997; Doyle et al., 2000).

African species of *Duguetia* form a relatively distinct clade with *Duguetia riberensis* within *Duguetia*. Continued recognition of *Pachypodanthium* would have rendered *Duguetia* paraphyletic, and consequently *Pachypodanthium* species recently have been transferred to *Duguetia* (Chatrou, 1998). In the past *Pachypodanthium* has been considered to be different from *Duguetia* primarily on the basis of wood anatomy and palynology. Vander Wyk and Canright (1956) pointed out a difference in vessel density, being low for *Pachypodanthium* and high for *Duguetia*. Increased sampling has rendered the argument untenable (Ter Welle, pers. comm. 1997). Pollen grains of the African species of *Duguetia* possess an extremely reduced exine consisting of only spinules. Le Thomas et al. (1994) interpreted these spinules as homologous with verrucae in the Neotropical species, which also show varying exine reductions. Both pollen and wood indicate that *Duguetia*, despite its uniform appearance and its presumable monophyly (van Zuilén, 1996), remains a

variable genus. Such is also demonstrated by our data matrix, with by far the largest part of the homoplasy deriving from *Duguetia*. The type of trichomes (character 2), asymmetric leaves (character 3), inflorescence position (character 9), and position of the thecae (character 18) represent features in our data matrix for which the African species seem anomalous. These aberrant character states are also encountered in a small subset of the Neotropical species of *Duguetia*. This reticulate nature of character expression, which was also found in a study of *Duguetia* leaf anatomy (Bakker & Visser, 1994), requires broader sampling of species; this is under way in a forthcoming analysis of *Duguetia* (Koek-Noorman & Maas, in prep.).

What are the character states that identify the combined *Duguetia-Fusaea* clade, the *Duguetia* clade, and the *Fusaea* clade? We traced all character states at the ingroup node, as well as at the internal nodes basal to the *Duguetia* clade and the *Fusaea* clade, respectively. The *Duguetia-Fusaea* clade is only characterized by traits that appear extensively within the Annonaceae, either by parallelism or by mosaic retention. Examples of these features include attributes such as trees, simple trichomes, symmetric leaves, free or basally connate sepals, and white to cream flower color. Thus, the *Duguetia-Fusaea* clade is not characterized by any synapomorphies (Table 2). The only character state that comes close to being synapomorphic is cucullate bracts, present in all *Duguetia* (except *D. neglecta*) and in *Fusaea*. However, it is one step more parsimonious to assume parallel evolution in *Duguetia* (and a subsequent loss in *D. neglecta*) and in *Fusaea*. The *Duguetia* clade and the *Fusaea* clade are characterized by four and three synapomorphies, respectively (Table 2).

To resolve relationships within the *Duguetia-Fusaea* clade we added some characters to the matrix that are novel, and which do not appear in the majority of other Annonaceae. This novelty does not



imply the change of one character state to another character state, and consequently these characters are difficult to polarize by outgroup comparison. This affects inflorescence character 10, implying a sympodial development of the inflorescence. The lack of any fertile inflorescence bracts in the tribe Bocageae, and the presence of lower bracts that do not produce axillary buds in most *Xylopia* and many *Gutteria*, illustrate the paucity of sympodially developing inflorescences in Annonaceae. Character 20 for stylar papillae can only be scored for those few annonaceous species in which the carpels are provided with a style. Receptacular characters 22 and 23 require the presence of pseudosyncarpous fruits, which outside the group under study are only present in *Anonidium* and in the *Annona* group. Arillate character 24 can only be scored for a small group of genera where the seeds possess a rudimentary aril (van Setten & Koek-Noorman, 1992).

Considering this, outgroup comparison is difficult to use to polarize the set of characters at hand. Possible outgroup taxa may be selected from previous phylogenetic analyses. Doyle and Le Thomas (1994) found *Toussaintia* and the xylopioids connected basally to the pseudosyncarps, all of them together forming a monophyletic group. Van Zuijlen (1996), based on limited sampling, however, found the *Duguetia-Fusaea* clade attached to a clade comprising *Uvaria*, *Uvariopsis*, *Isolona*, *Monodora*, *Annona*, and *Rollinia*. All these genera suffer from the comparative lack of the above-mentioned characters. The only exceptions are genera from the *Annona* group, which share sympodially developing inflorescences, pseudosyncarpous fruits, and rudimentary arils with the *Duguetia* alliance.

The character set as herein designed cannot establish the monophyly of the combined *Duguetia-Fusaea* clade, and cannot yield a corroborated positioning of the clade within the Annonaceae, as the selected characters obscure the choice of outgroup taxa. For the monophyly of the combined *Duguetia-Fusaea* clade we rely on Doyle and Le Thomas (1996) and Le Thomas et al. (1994).

Our study, as well as the cladistic analysis of the tribe Bocageae (Johnson & Murray, 1995), shows that the search for new morphological characters with little generality, can be illuminative for analyses at low taxonomic level. The combined *Duguetia-Fusaea* clade (the "pseudosyncarps") shows no synapomorphies or unique combinations of characters. The challenge for future research will be to find synapomorphies that circumscribe more inclusive, monophyletic groups, to find new characters with more generality. Otherwise, it will be difficult

to bring the phylogeny of Annonaceae beyond floating groups of genera with rather well resolved internal relationships.

Considering the geographical distribution of the taxa (Fig. 2), the pattern is straightforward, deriving from the break-up of Gondwana. Both the *Duguetia* clade and the *Fusaea* clade apparently existed before this event. Within the *Fusaea* clade, closer phylogenetic relationships correspond with geographical proximity. *Fusaea* and *Duckeanthus* evolved as the Neotropical representatives, and *Le-testudoxa* and *Pseudartabotrys* as the African ones. We cannot address whether the biogeographic isolation of the African species of *Duguetia* corresponds with their constituting a separate clade within *Duguetia*, or whether some of the African species have closer sister-group relationships with Neotropical species. Analyses including more species of this genus, which will have to resolve this, are forthcoming.

#### Literature Cited

- Bakker, M. E. & W. J. Visser. 1994. Studies in Annonaceae XIX. Leaf anatomy of *Duguetia* St. Hil. (Annonaceae). Bot. Jahrb. Syst. 116: 83–111.
- Bremer, K. 1988. The limits of amino acid sequence data in angiosperm phylogenetic reconstruction. Evolution 42: 795–803.
- Briechle-Mäck, M. H. 1994. Beiträge zur Histogenese der Blüten und Früchte pseudosynkarper Annonaceen-Arten. Deutsche Hochschulschriften 1028. Hänsel-Hohenhausen, Egelsbach.
- Chatrou, L. W. 1998. Changing Genera: Systematic Studies in Neotropical and West African Annonaceae. Ph.D. Dissertation, Utrecht University, Utrecht.
- & P. He. 1999. Studies in Annonaceae XXXIII. A revision of *Fusaea* (Baill.) Saff. Brittonia 52: 181–203.
- Donoghue, M. J., R. G. Olmstead, J. F. Smith & J. D. Palmer. 1992. Phylogenetic relationships of Dipsacales based on *rbcL* sequences. Ann. Missouri Bot. Gard. 79: 333–345.
- Doyle, J. A. & A. Le Thomas. 1994. Cladistic analysis and pollen evolution in Annonaceae. Acta Bot. Gallica 141: 149–170.
- & ———. 1995. Evolution of pollen characters and relationships of African Annonaceae: Implications of a cladistic analysis. Pp. 241–254 in A. Le Thomas & E. Roche (editors), 2<sup>e</sup> Symposium de Palynologie africaine, Tervuren (Belgique). Centre International pour la Formation et les Echanges Géologiques, Orleans.
- & ———. 1996. Phylogenetic analysis and character evolution in Annonaceae. Bull. Mus. Natl. Hist. Nat., B, Adansonia 18: 279–334.
- & ———. 1997. Significance of palynology for phylogeny of Annonaceae: Experiments with removal of pollen characters. Pl. Syst. Evol. 206: 133–159.
- , P. Bygrave & A. Le Thomas. 2000. Implications of molecular data for pollen evolution in Annonaceae. Pp. 259–284 in M. M. Harley, C. M. Morton & S. Blackmore (editors), Pollen and Spores: Morphology and Biology. Royal Botanic Gardens, Kew.

- Fries, R. E. 1934. Revision der Arten einiger Anonaceen-Gattungen III. Acta Horti Berg. 12(1): 1–220.
- . 1959. Annonaceae. Pp. 1–171 in A. Engler & K. Prantl (editors), Die natürlichen Pflanzenfamilien, 2nd ed., 17aII. Duncker & Humblot, Berlin.
- Garwood, N. C. 1995. Studies in Annonaceae XX. Morphology and ecology of seedlings, fruits and seeds of selected Panamanian species. Bot. Jahrb. Syst. 117: 1–152.
- Heusden, E. C. H. van. 1992. Flowers of Annonaceae: Morphology, classification, and evolution. Blumea Suppl. 7: 1–218.
- Hillis, D. M. & J. J. Bull. 1993. An empirical test of bootstrapping as a method for assessing confidence in phylogenetic analysis. Syst. Biol. 42: 182–192.
- Hooker, J. D. & T. Thomson. 1855. Flora Indica 1: 86–153. W. Pamplin, London.
- Hutchinson, J. 1964. The Genera of Flowering Plants. Dicotyledones, Vol. 1. Clarendon Press, Oxford.
- Johnson, D. M. & N. A. Murray. 1995. Synopsis of the tribe Bocageae (Annonaceae) with revisions of *Cardiopetalum*, *Froesiodendron*, *Trigynaea*, *Bocagea*, and *Hornschuchia*. Brittonia 47: 248–319.
- Koek-Noorman, J., A. K. van Setten & C. M. van Zuilén. 1997. Studies in Annonaceae XXVI. Flower and fruit morphology in Annonaceae. Their contribution to patterns in cluster analysis. Bot. Jahrb. Syst. 119: 213–230.
- Le Thomas, A. 1969. Annonacées. Pp. 1–371 in A. Aubréville (editor), Flore du Gabon, Vol. 16. Muséum national d'histoire naturelle, Paris.
- . 1980–1981. Ultrastructural characters of the pollen grains of African Annonaceae and their significance for the phylogeny of the primitive angiosperms. Pollen & Spores 22: 267–342, 23: 5–36.
- , B. Lugardon & J. A. Doyle. 1994. Pollen ultrastructure and relationships of *Fusaea* (Baillon) Safford and *Duguetia* A. Saint-Hilaire (Annonaceae). Rev. Palaeobot. Palynol. 83: 55–64.
- Maddison, D. R. 1991. The discovery and importance of multiple islands of most-parsimonious trees. Syst. Zool. 40: 315–328.
- Maddison, W. P. & D. R. Maddison. 1992. MacClade, version 3.04. Sinauer Associates, Sunderland, Massachusetts.
- Patterson, C. 1982. Morphological characters and homology. Pp. 21–74 in K. A. Joysey & A. E. Friday (editors), Problems of Phylogenetic Reconstruction. The Systematics Association Special Volume no. 21. Academic Press, London and New York.
- Schatz, G. E. & A. Le Thomas. 1993. Annonaceae: A primitive dicot family with an ancient center in Africa–South America. Pp. 86–104 in P. Goldblatt (editor), Biological Relationships Between Africa and South America. Yale Univ. Press, New Haven.
- Setten, A. K. van & J. Koek-Noorman. 1986. Studies in Annonaceae VI. A leaf anatomical survey of genera of Annonaceae in the Neotropics. Bot. Jahrb. Syst. 108: 17–50.
- & ———. 1992. Fruits and seeds of Annonaceae. Morphology and its significance for classification and identification. Studies in Annonaceae XVII. Biblioth. Bot. 142: 1–101. E. Schweizerbart'sche Verlagsbuchhandlung, Stuttgart.
- Svoma, E. 1998. Fruit structure diversity in Annonaceae. Annonaceae Newsl. 12: 68–72.
- Swofford, D. L. 1993. PAUP: Phylogenetic Analysis Using Parsimony, version 3.1.1. Computer program distributed by the Illinois Natural History Survey, Champaign, Illinois.
- Vander Wyk, R. W. & J. E. Canright. 1956. The anatomy and relationships of the Annonaceae. Trop. Woods 104: 1–24.
- Walker, J. W. 1971. Pollen morphology, phytogeography, and phylogeny of the Annonaceae. Contr. Gray Herb. 202: 3–131.
- Zuilén, C. M. van. 1996. Patterns and Affinities in the *Duguetia* Alliance (Annonaceae). Molecular and Morphological Studies. Ph.D. Dissertation, Utrecht University, Utrecht.
- , J. Koek-Noorman & P. J. M. Maas. 1995. A phylogenetic analysis of *Duguetia* (Annonaceae) based on morphological data. Pl. Syst. Evol. 194: 173–188.
- Appendix 1. Voucher specimens for taxa studied.
- Annona sericea* Dunal  
FRENCH GUIANA. Saint-Maurice-Region de Saint Laurent, Piste d'Apatou, 8 Feb. 1990 (fr), *Cremers & Hoff 11256* (P, U, US). GUYANA. **East Berbice-Corentyne**: near Thompson's farm (Timehri), 31 Oct. 1981 (fl, fr), *Maas et al. 5932* (NY, U, WU). **Upper Demerara-Berbice**: vicinity of Mabura Hill, trail from Mabura Hill-Linden road to Demerara Landing, 26 Aug. 1988 (fl buds, fr), *Maas et al. 7144* (K, P, U, WU). SURINAM. **Marowijne**: along road near Mongotapoe, 10 June 1954 (fl buds, yfr), *Lindeman 6133* (NY, U). VENEZUELA. **Bolívar**: Street Alcabala Casa Blanca towards Isla Anacoco, 28 July 1981 (yfr), *Aymard et al. 313* (MO).
- Duckeanthus grandiflorus* R. E. Fr.  
BRAZIL. **Amazonas**: São Felipe, upper Rio Negro, 9 Mar. 1944 (fr), *Baldwin 3584* (S, US); Camanáos, upper Rio Negro, 13 Oct. 1932 (fl), *Ducke 23904* (B, K, RB, S, US); right bank of Rio Negro, Ilha Tamanduá (locally Ilha Marajó), near Carapanã, 18 Oct. 1987 (fl), *Maas et al. 6772* (NY, U), *Maas et al. 6778* (NY, U); Ilha das Flores, Rio Negro, 17 Feb. 1959 (fr), *Rodrigues* (S).
- Duguetia argentea* (R. E. Fr.) R. E. Fr.  
BRAZIL. **Amazonas**: km 124 of Manaus–Porto Velho Hwy., 25 Mar. 1974 (fr), *Campbell et al. P20915* (G, INPA, U); Carapanã, Upper Rio Negro, 17 Oct. 1987 (fl), *Maas et al. 6764* (NY, U). COLOMBIA. **Amazonas-Vaupés**: Río Apaporis, Jino Gojé, between Río Piraparaná and Río Popeyaká, Caño Unguyá, alt. 250 m, 3–11 Sep. 1952 (fl, fr), *García-Barriga 14366* (COL, US). VENEZUELA. **Amazonas**: San Carlos de Río Negro, 21 Mar.–17 Apr. 1981 (yfr), *Delascio C. et al. 9425* (VEN); Isla Sebastián, Río Casiquiare, between Boca and Chapazón, alt. 120 m, 31 Jan. 1980 (fl, fr), *Liesner & Clark 8939* (MO, U, VEN).
- Duguetia asterotricha* (Diels) R. E. Fr.  
BRAZIL. **Amazonas**: km 118 of Manaus–Caracará Hwy., Mar. 1976 (fl), *D. Coêlho & Damião 767* (INPA); Reserva Florestal Ducke, alt. 80 m, 16 Jan. 1990 (fr), *Gentry & Revilla 69142* (U); ibidem, 18 Jan. 1990 (fl), *Gentry & Nelson 69219* (U); Manaus, 2 km from Tarumãzinho, 18 Nov. 1975 (fl), *O. P. Monteiro INPA53548* (INPA); km 70 of Manaus–Itacoatiara Hwy., 31 May 1994 (fl), *Webber 1477* (HUAM). PERU. **Loreto**: Mishuyacu, near Iquitos, Oct.–Nov. 1929 (fl), *Klug 86* (F, NY, US).
- Duguetia barteri* (Benth.) Chatrou  
CAMEROON. **Centre-Sud**: bank of the Nyong River, 40 km SE of Yaoundé, alt. 550 m, 9 Nov. 1961 (fr), *Breteler 2013* (BR, K, P, WAG). **Littoral**: right bank of Ouem

River, near confluence with Sanaga River, 6 km SW of Masok, alt. 350 m, 4 Apr. 1965 (fl), *Leeuwenberg 5377* (BR, K, MO, WAG); Lombé, Tissongo, strip C, 26 July 1976 (fr), *McKey & Gartlan 139* (E). GABON. **Ogooué-Ivindo:** Ipassa, 10 km S of Makokou, small island in Ivindo River, alt. 500 m, 27 Nov. 1971 (fr), *Hladik 1835C* (US); Ipassa, 10 km from Makokou, Ivindo River, alt. 500 m, 14 Mar. 1975 (fl), *Hladik 2641* (P). NIGERIA. **Ondo:** Marbara River, Ibaji-Ojoku Reserve, 11 Mar. 1934 (fr), *Taylor 13* (FHO).

*Duguetia confinis* (Engl. & Diels) Chatrou

CAMEROON. **Centre-Sud:** ca. 16 km from Kribi, Ebolowa road, Bidou plantation, Kienké Forest Reserve, 3 Feb. 1969 (fr), *Bos 3844* (WAG); Bipindi, 1904 (fl), *Zenker 3195* (B, BR, E, G, GOET, L, M, MO, P, S, WU, Z). GABON. **Estuaire:** near Libreville, Apr. 1897 (fl), *Klaine s.n.* (P). **Moyen-Ogooué:** SW of Lambaréné, near Lake Ezanga, Conoco drilling site, alt. 20 m, 3 Feb. 1991 (fr), *McPherson 15195* (MO). **Nyanga:** 10 km on Maambi River, 7 Aug. 1992 (fl), *Wieringa & van de Poll 1360* (WAG). **Ogooué-Maritime:** Rabi, N of Shell camp, alt. 50 m, 26 Nov. 1994 (fl, fr), *Wieringa & van Nek 3290* (WAG).

*Duguetia dilabens* Chatrou & Repetur

GABON. **Centre-Sud:** forest reserve of Kienké Kribi, Ebolowa km 16, 5 Jan. 1968 (fr), *Bamps 1679* (BR). **Littoral:** Lombé, Tissongo, 7 Aug. 1976 (fr), *McKey & Gartlan 194* (K). **Ngounié:** new road from Mouila to Yeno, 5 km on either side of Kembele village, alt. 500 m, 20 July 1986 (fl, fr), *Thomas & Wilks 6510* (MO, P, WAG).

*Duguetia furfuracea* (A. St.-Hil.) Benth. & Hook.f.

BOLIVIA. **Santa Cruz:** Prov. Velasco, Serrania de Huanchaca, alt. 800 m, 3–4 Dec. 1987 (fl, fr), *Thomas et al. 5578* (U). BRAZIL. **Bahia:** 15–20 km from Andaraí, along the road to Itaeté which branches E off the road to Mucugé, alt. 500–600 m, 13 Feb. 1977 (fl, fr), *Harley et al. 18634* (CEPEC, F, IPA, K, MO, NY, P, U, US). **Distrito Federal:** 20 km S of Brasília, on road to Belo Horizonte, alt. 700–1000 m, 26 Aug. 1964 (fl), *Irwin & Soderstrom 5572* (NY, S, SP, TEX). **Goiás:** Mun. Mineiros, 14 km E of turn-off for Mineiros, 1 Feb. 1986 (fl, fr), *Andersson & Hagberg 1635* (GB, U). **Mato Grosso:** Mun. Campo Grande, road from Campo Grande to Rochedo, 12 July 1969 (fl, fr), *Hatschbach & Guimarães 21837* (S, UC). **Minas Gerais:** Serra do Espinhaço, 6 km N of Gouvêia on road to Diamantina, alt. 1250 m, 10 Apr. 1973 (fl, fr), *W. R. Anderson et al. 8585* (F, MO, NY, RB, U, UB, US). **São Paulo:** Fazenda Hollambra, 35 km N of Campinas, alt. 600 m, 25 Feb. 1976 (fl), *Shepherd & Gibbs 11246* (K, MG, NY). PARAGUAY. **Amambay:** 14 km S of Bella Vista, alt. 250 m, 25 Mar. 1983 (fl), *Simonis et al. 197* (AAU, F, G, U).

*Duguetia inconspicua* Sagot

BRAZIL. **Amapá:** Rio Araguari, camp 13, 9 Oct. 1961 (fr), *J. M. Pires et al. 51633* (NY). **Pará:** basin of Rio Trombetas, 3 km up Rio Mapueira from Cachoeira Porteira, 30 May 1974 (fr), *Campbell et al. P22301* (NY, U). FRENCH GUIANA. Mt. Bellevue de l'Inini, alt. 700 m, 17 Aug. 1985 (fr), *de Granville et al. 7580* (B, CAY, P, U). GUYANA. Seballi Compartment, ca. 3 km S of Mabura, alt. 0–100 m, 1 Nov. 1991 (fl, fr), *Polak & Maas 379* (B, F, K, LZ, MO, U, ULM, WU). SURINAM. Nassau Mts., Marowijne River, alt. 430–520 m, 31 Dec. 1954 (fr), *Cowan & Lindeman 39044* (NY, S, U, US).

*Duguetia lanceolata* A. St.-Hil.

BRAZIL. **Minas Gerais:** Lagoa Santa, 8 Mar. 1865 (fl, fr), *Warming s.n.* (C, F, K, NY, P, S). **Paraná:** Sengés, 29

June 1910 (fl buds), *Dusén 9939* (GH, NY, S). **Santa Catarina:** Vargem Grande, Lauro Müller, alt. 350 m, 24 Oct. 1958 (fl), *Reitz & Klein 7483* (B, K, S). **São Paulo:** Mun. Brotas, Pepira-Mirim, Experimental Station of Mogi-Guaçu, Arboretum, alt. 500 m, 22 Sep. 1992 (fl), *Maas et al. 8043* (LZ, U, UEC, ULM, WU).

*Duguetia neglecta* Sandw.

GUYANA. Base of Mt. Makarapan, near rapids of Makarapan Creek, 15 Sep. 1988 (fr), *Maas et al. 7433* (B, BBS, F, MO, NY, U, VEN, WIS); Mabura Hill Nature Reserve, 25 Aug. 1990 (fl, fr), *Polak et al. 28* (U); Labakabra Creek, Tiger Creek, Essequibo River, 26 Aug. 1937 (fl), *Sandwith 1214* (G, K, NY). SURINAM. Area of Kabalebo Dam project, along road between km 29 and 30, 1 Sep. 1980 (fl, fr), *Lindeman, Görts-van Rijn et al. 59* (F, K, NY, U).

*Duguetia quitarensis* Benth.

BOLIVIA. **Pando:** Río Madeira, 12 km above Abunã, 20 July 1968 (yfr), *Prance et al. 6213* (INPA, MG). BRAZIL. **Amazonas:** Mun. São Paulo de Olivença, near Palmares, 11 Sep. to 26 Oct. 1936 (fl), *Krukoff 8260* (A, BM, F, G, K, LE, MICH, MO, NY, S, U). **Pará:** Rio Cuminá-Mirim, 13 Dec. 1906 (fl), *Ducke MG7951* (BM, G, MG). COLOMBIA. **Meta:** Sierra de la Macarena, Caño Ciervo, alt. 600 m, 12 Jan. 1950 (fr), *Philipson et al. 2084* (COL, S, US). ECUADOR. **Napo:** La Joya de los Sachas, Parque Nacional de Yasuní, alt. 230 m, 8–15 July 1993 (fl), *Dik 54* (MO). GUYANA. Kanuku Mts., Puwib River, alt. 80–100 m, 13 Feb. 1985 (fl, fr), *Jansen-Jacobs et al. 184* (K, U, WIS). PERU. **Huánuco:** Pachitea, W of Puerto Inca, alt. 250–300 m, 14 Sep. 1982 (fr), *Foster 8778* (MO, U). **Loreto:** Prov. Maynas, Río Momon, 0–5 km from confluence with Río Nanay, alt. 100 m, 15 Nov. 1984 (fl, fr), *Maas et al. 6298* (AMAZ, K, U, USM, WIS). **Ucayali:** Prov. Coronel Portillo, Bosque A. von Humboldt, km 86 of road from Pucallpa to Tingo Maria, alt. 250 m, 2 Nov. 1984 (fl), *Maas et al. 6180* (U, USM). VENEZUELA. **Amazonas:** 5 km E of San Fernando de Atabapo, N bank of Río Orinoco, alt. 95 m, 4 May 1979 (fr), *Davidse et al. 17183* (MO, U).

*Duguetia riberensis* Aristeg. ex Maas & Boon

VENEZUELA. **Apure:** Distr. San Fernando, mouth of Río Arauca at its intersection with Río Orinoco, alt. 3 m, 14–15 May 1977 (fl), *Davidse & González 13219* (MO, U). **Bolívar:** Puerto Ordaz, San Félix, Apr. 1964 (fl), *Aristeguieta 5308* (HBG, U, VEN). **Guárico:** margins of Río Orituco, 5 km of Calabozo, Apr. 1963 (fl), *Aristeguieta & Tamayo 5087* (HBG, VEN).

*Duguetia riparia* Huber

BOLIVIA. **Pando:** S bank of Río Abunã, between Cachoeiras Tres S and Fortaleza, 3–16 km above mouth, 18 July 1968 (fl buds), *Prance et al. 6132* (INPA, NY). BRAZIL. **Amazonas:** Reserva Forestal Ducke, km 26 of Manaus–Itacoatiara Hwy., 12 Oct. 1995 (fl), *Miralha, Maas et al. 308* (INPA, U). **Pará:** Belém, Reserva Mocambo, 8 Nov. 1995 (fl, fr), *Maas et al. 8360* (INPA, K, LZ, MG, MO, NY, U, ULM, WIS). COLOMBIA. **Caquetá:** Quebrada El Engaño, 26 Nov. 1991 (fl), *Duivenvoorden et al. 1669A* (U). FRENCH GUIANA. Oyapock River, Grande Roche, Saut Cafesoca, 31 July 1969 (fl), *Oldeman T.425* (CAY, P, U). SURINAM. S of Juliana top, 13 km N of Lucie River, alt. 350 m, 9 Aug. 1963 (fl), *Irwin et al. 54639* (B, F, G, M, NY, P, US).

*Duguetia spixiana* Mart.

BOLIVIA. **Beni:** Prov. Yacuma, SE of San Borja, alt. 350 m, 14 Sep. 1988 (fl), *Beck 16749* (LPB, U). BRAZIL. **Acre:** Mun. Senador Guiomard, km 33 of BR 317, 11

Oct. 1980 (fl), *Cid & Nelson 2834* (MG, NY, U). **Amazonas:** Mun. São Paulo de Olivença, near Palmares, basin of Rio Solimões, 11 Sep.–26 Oct. 1936 (fl, fr), *Krukoff 8402* (A, BM, F, G, K, LE, MICH, MO, NY, P, S, U). COLOMBIA. **Amazonas:** Quebrada Arara, 2 hours N of Leticia, near Río Amazonas, 27 Jan. 1971 (fl), *Croat 7546* (MO). ECUADOR. **Napo:** 4 km N of Coca, alt. 250 m, 15 Sep. 1986 (fl), *Palacios & Neill 1312* (MO, U). PERU. **Loreto:** 7 km SW of Iquitos, 30 July 1972 (fl, fr), *Croat 18572* (AAU, C, F, MO, NA, NY). **Ucayali:** Prov. Coronel Portillo, Carretera Alexandro, ca. 8 km W of Bosque von Humboldt, alt. 250 m, 2 Nov. 1984 (fl, fr), *Maas et al. 6183* (MO, U, USM, WIS).

*Duguetia staudtii* (Engl. & Diels) Chatrou

CAMEROON. **Littoral:** Douala-Edea Reserve, Tissongo Study Area, Transect B, June 1976 (fr), *Waterman & McKey 879* (U). CENTRAL AFRICAN REPUBLIC. Sangha Economique Prefecture, Ndakan, Gorilla study area, alt. 350 m, 1 Apr. 1988 (fr), *Harris & Fay 416* (MO, P). CONGO-BRAZZAVILLE. **Sangha:** W slope of Mt. Nabema, alt. 600–900 m, 15 Nov. 1991 (fr), *Thomas et al. 8877* (MO). GABON. **Woleu-Ntem:** Bitam, 20 Dec. 1933 (yfr), *Le Testu 9424* (BM, BR). IVORY COAST. **Néy:** 61 km N of Sassandra, W of Niapidou, alt. 100 m, 26 Jan. 1959 (fl, fr), *Leeuwenberg 2579* (BR, UC, Z). LIBERIA. **Bong:** Bong range, 15 Aug. 1962 (fl, fr), *Voorhoeve 1176* (B, BR, K). **Nimba:** Nimba Mts., alt. 500 m, 28 Feb. 1962 (fl), *Voorhoeve 891* (WAG). NIGERIA. **Calabar:** Oban, 9 Mar. 1959 (fl), *Talbot 1494* (BM, Z).

*Duguetia uniflora* (DC. ex Dunal) Mart.

BRAZIL. **Amazonas:** Rio Içana, 18 Nov. 1945 (fl), *Fróes 21407* (F, IAN, K, NY, US); Igarapé Tarumã-Açu, 30 km NW of Manaus, 8 Oct. 1990 (fl), *Miralha, Maas et al. 232* (U, ULM). **Roraima:** Rio Branco, at mouth of Rio Itapera, 8 June 1989 (fr), *Mori et al. 20424* (U). VENEZUELA. **Amazonas:** Tamatama, Upper Río Orinoco, alt. 125 m, 13 July 1942 (fr), *Ll. Williams 15859* (A, F, G, NY, RB, S, US, W).

*Fusaea longifolia* (Aubl.) Saff.

BOLIVIA. **Beni:** km 13 of Riberalta–Guayaramerin road, 19 Nov. 1989 (fl), *Daly et al. 6260* (MO, U). BRAZIL. **Amapá:** Mun. Oiapoque, 60 km SSE of Oiapoque, 1 Dec. 1984 (fl), *Mori et al. 17100* (NY, U). **Amazonas:** km 155 of Manaus–Itacoatiara Road, 16 Dec. 1974 (fr), *Gentry & Ramos 13345* (MO, U). **Rondônia:** Angustura, Rio Machado region, 5 Dec. 1931 (fr), *Krukoff 1537* (A, G, MICH, MO, NY, S, U). **Roraima:** Serra da Lua, 21 Jan. 1969 (fl buds), *Prance et al. 9367* (NY, U). COLOMBIA. **Antioquia:** Mun. Caucasia, road to Nechí, 14 km from Caucasia–Planeta Pica Road, Hacienda La Candelaria, alt. 50 m, 24 Nov. 1986 (fl), *Zarucchi & Cárdenas 4250* (COL, MO, NY, U). **Santander:** Puerto Parra-Campo Capote, 10 Dec. 1979 (fl, fr), *Rentería Arriaga et al. 2136* (COL, HUA); **Vaupés:** vicinity of Mitú, 20 May 1976 (fr), *Zarucchi 1607* (COL, GH, K). FRENCH GUIANA. Les Eaux Claires, near Crique Tortue, alt. 200 m, 10 Feb. 1993 (fl), *Maas et al. 8066* (U). GUYANA. **Upper**

**Takutu-Upper Essequibo:** Kuyuwini landing, Kuyuwini River, alt. 200 m, 2 Feb. 1991 (fl), *Jansen-Jacobs et al. 2313* (U). PERU. **Loreto:** Jenaro Herrera, IIAP, Arboretum, alt. 120 m, 25 Oct. 1994 (fl buds, yfr), *Chatrou et al. 2* (AMAZ, U, USM, WU). **Madre de Dios:** Parque Nacional del Manú, 14 Oct. 1986 (fl buds) *Foster et al. 11824* (U).

*Fusaea peruviana* R. E. Fr.

PERU. **Amazonas:** Río Santiago, 2 km from Caterpiza, 19 Nov. 1979 (fr), *Huashikat 1326* (MO). **Huánuco:** W Sira Mts., 26 km S of Puerto Inca, Panguana Biological Field station, alt. 260 m, 1 Feb. 1993 (fl), *Listabarth & Vasquez 11-1293* (U), alt. 260–350 m, 20 Oct. 1994 (yfr), *Rainer 244* (U, WU). **Loreto:** Río Napo, Sucusari, Explornapo Camp, alt. 140 m, 3 Nov. 1994 (fl buds, fr), *Chatrou et al. 7* (AMAZ, NY, U, USM, WU); Andoas, Río Pastaza near Ecuador border, 15 Aug. 1980 (fl, fr), *Gentry et al. 29779* (F, MO, U); km 44 of Iquitos–Nauta road, 12 Dec. 1988 (fl, fr), *Vásquez & Jaramillo 11378* (MO, U, USM).

*Letestudoxa bella* Pellegr.

CAMEROON. **Centre-Sud:** near Kom Valley, 25 km E of confluent of Ntem River and Akom River, near Ebolowa, 5 Mar. 1970 (fl, fr), *Letouzey 10097* (BR, P). GABON. **Haut-Ogooué:** 70 km SSW of Moanda, alt. 730 m, 13 Oct. 1970 (fl buds), *Breteler 6877* (WAG); 42 km SE of Lambaréné, 3 Oct. 1968 (fl), *Breteler 5805* (WAG). **Ngounié:** Moucongo, 19 Oct. 1926 (fl), *Le Testu 6336* (BR, P). **Ogooué-Maritime:** Doudou Mts., ca. 35 km of Doussala, 27 Aug. 1985 (fl), *Reitsma 1432* (WAG); Rabi, 3 km S of platform Rabi 13, near old incat camp, alt. 50 m, 28 Sep. 1994 (fl), *Wieringa & Nzabi 2797* (WAG).

*Letestudoxa glabrifolia* Chatrou & Repetur

GABON. **Woleu-Ntem:** ca. 10 km on Tchimbélé–Assok road, alt. 630 m, 14 Sep. 1994 (fl buds), *Breteler 12858* (U, WAG); Tchimbélé, on lake border near dam, alt. 530 m, 26 Dec. 1989 (fr), *Wieringa 293* (WAG); Cristal Mts., 10 km on Tchimbélé–Kinguélé road, alt. 570 m, 24 Jan. 1983 (fr), *de Wilde 198* (WAG).

*Letestudoxa lanuginosa* Le Thomas

GABON. **Woleu-Ntem:** Nkout, 13 Oct. 1933 (fl), *Le Testu 9320* (BR, MO, P); Oyem, 7 May 1934 (fl), *Le Testu 9570* (P).

*Pseudartabotrys letestui* Pellegr.

GABON. **Estuaire:** E part of presidential reserve Wonga-Wongué, ca. 100 km S of Libreville, alt. 100 m, 3 Mar. 1983 (fr), *de Wilde et al. 890* (WAG). **Ogooué-Maritime:** Rabi-Kounga, E of Rabi, 29 Oct. 1991 (fl), *Breteler & Jongkind 10211* (WAG); near Rabi, Shell Oil Company's camp, 24 Nov. 1991 (fl), *McPherson 15564* (BR); Rabi, 1.5 km along pipeline to Echira, alt. 40 m, 24 Nov. 1994 (fl, fr), *Wieringa & van Nek 3273* (WAG); 22 km along a track leading in W direction into the Doudou Mts., alt. 150 m, 3 Dec. 1986 (fl), *de Wilde et al. 9136* (P, WAG); Rabi, Shell-Gabon, just E of the airstrip, alt. 80 m, 22 Jan. 1993 (fl, fr), *de Wilde & van der Maesen 10888* (WAG).