

DENON

AV SURROUND RECEIVER

AVR-4810

Owner's Manual

Bedienungsanleitung

Manuel de l'Utilisateur

GUI *Graphical User Interface*

English

Use this manual in combination with the operating guide displayed on the GUI screen.

GUI Menu Operation (☞ page 29)
GUI Menu Map (☞ page 28)
Language (☞ page 56)
Remote Control Unit Operations (☞ page 99)

Deutsch

Verwenden Sie dieses Handbuch zusammen mit den Bedienungsanweisungen auf dem GUI-Bildschirm.

GUI-Menübedienung (☞ Seite 29)
GUI-Menüplan (☞ Seite 28)
Sprache (☞ Seite 56)
Bedienung mit der Fernbedienung (☞ Seite 99)

Français

Utilisez ce manuel en même temps que le guide d'utilisation affiché sur l'écran GUI (Interface graphique).

Fonctionnement du menu de l'interface graphique GUI (☞ page 29)
Plan du menu de l'interface graphique GUI (☞ page 28)
Langue (☞ page 56)
Fonctionnement de la télécommande (☞ page 99)

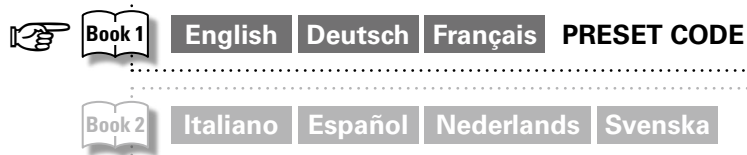

SAFETY PRECAUTIONS

CAUTION
RISK OF ELECTRIC SHOCK
DO NOT OPEN

CAUTION:
TO REDUCE THE RISK OF ELECTRIC SHOCK, DO NOT REMOVE COVER (OR BACK). NO USER-SERVICEABLE PARTS INSIDE. REFER SERVICING TO QUALIFIED SERVICE PERSONNEL.

The lightning flash with arrowhead symbol, within an equilateral triangle, is intended to alert the user to the presence of uninsulated "dangerous voltage" within the product's enclosure that may be of sufficient magnitude to constitute a risk of electric shock to persons.

The exclamation point within an equilateral triangle is intended to alert the user to the presence of important operating and maintenance (servicing) instructions in the literature accompanying the appliance.

WARNING:
TO REDUCE THE RISK OF FIRE OR ELECTRIC SHOCK, DO NOT EXPOSE THIS APPLIANCE TO RAIN OR MOISTURE.

IMPORTANT SAFETY INSTRUCTIONS

1. Read these instructions.
2. Keep these instructions.
3. Heed all warnings.
4. Follow all instructions.
5. Do not use this apparatus near water.
6. Clean only with dry cloth.
7. Do not block any ventilation openings.
Install in accordance with the manufacturer's instructions.
8. Do not install near any heat sources such as radiators, heat registers, stoves, or other apparatus (including amplifiers) that produce heat.
9. Protect the power cord from being walked on or pinched particularly at plugs, convenience receptacles, and the point where they exit from the apparatus.
10. Only use attachments/accessories specified by the manufacturer.
11. Use only with the cart, stand, tripod, bracket, or table specified by the manufacturer, or sold with the apparatus. When a cart is used, use caution when moving the cart/apparatus combination to avoid injury from tip-over.
12. Unplug this apparatus during lightning storms or when unused for long periods of time.
13. Refer all servicing to qualified service personnel. Servicing is required when the apparatus has been damaged in any way, such as power-supply cord or plug is damaged, liquid has been spilled or objects have fallen into the apparatus, the apparatus has been exposed to rain or moisture, does not operate normally, or has been dropped.
14. Batteries shall not be exposed to excessive heat such as sunshine, fire or the like.



CAUTION:

To completely disconnect this product from the mains, disconnect the plug from the wall socket outlet.
The mains plug is used to completely interrupt the power supply to the unit and must be within easy access by the user.

VORSICHT:

Um dieses Gerät vollständig von der Stromversorgung abzutrennen, ziehen Sie bitte den Stecker aus der Wandsteckdose.
Der Netzstecker wird verwendet, um die Stromversorgung zum Gerät völlig zu unterbrechen; er muss für den Benutzer gut und einfach zu erreichen sein.

PRECAUTION:

Pour déconnecter complètement ce produit du courant secteur, débranchez la prise de la prise murale.
La prise secteur est utilisée pour couper complètement l'alimentation de l'appareil et l'utilisateur doit pouvoir y accéder facilement.

ATTENZIONE:

Per scollegare completamente questo prodotto dalla rete di alimentazione elettrica, scollegare la spina dalla relativa presa a muro.
La spina di rete viene utilizzata per interrompere completamente l'alimentazione all'unità e deve essere facilmente accessibile all'utente.

PRECAUCIÓN:

Para desconectar completamente este producto de la alimentación eléctrica, desconecte el enchufe del enchufe de la pared.
El enchufe de la alimentación eléctrica se utiliza para interrumpir por completo el suministro de alimentación eléctrica a la unidad y debe de encontrarse en un lugar al que el usuario tenga fácil acceso.

WAARSCHUWING:

Om de voeding van dit product volledig te onderbreken moet de stekker uit het stopcontact worden getrokken.
De netstekker wordt gebruikt om de stroomtoevoer naar het toestel volledig te onderbreken en moet voor de gebruiker gemakkelijk bereikbaar zijn.

FÖRSIKTIHETSMÅTT:

Koppla loss stickproppen från eluttaget för att helt skilja produkten från nätet.
Stickproppen används för att helt bryta strömförsörjningen till apparaten, och den måste vara lättillgänglig för användaren.

DECLARATION OF CONFORMITY

Hereby, D&M Holdings Inc., Denon Brand Company declares that this product AVR-4810 is in compliance with the essential requirements and other relevant provisions of Directive 1999/5/EC, in conformity with the following standards:
EN60065, EN55013, EN55020, EN55022, EN55024, EN61000-3-2, EN61000-3-3, EN300328, EN301489-01, EN301489-17 and EN50385.
The declaration of conformity may be consulted to our European representative, DENON Europe.

ÜBEREINSTIMMUNGSERKLÄRUNG

Hiermit erklärt D&M Holdings Inc., Denon Brand Company, dass sich das Gerät AVR-4810 in Übereinstimmung mit den grundlegenden Anforderungen und den übrigen einschlägigen Bestimmungen der Richtlinie 1999/5/EG befindet, den folgenden Standards entspricht:
EN60065, EN55013, EN55020, EN55022, EN55024, EN61000-3-2, EN61000-3-3, EN300328, EN301489-01, EN301489-17 und EN50385.
Wenden Sie sich bei Fragen zur Konformitätserklärung an unseren europäischen Vertreter, DENON Europe.

CE 0413

R&TTE Directive 1999/5/EC

This product may be operated in the following countries;

AT	BE	CZ	DK	FI
FR	DE	GR	HU	IE
IT	NL	PL	PT	SK
ES	SE	GB	NO	CH

DECLARATION DE CONFORMITE

Par la présente, D&M Holdings Inc., Denon Brand Company déclare que l'appareil AVR-4810 est conforme aux exigences essentielles et aux autres dispositions pertinentes de la directive 1999/5/CE, e conforme alle seguenti normative:
EN60065, EN55013, EN55020, EN55022, EN55024, EN61000-3-2, EN61000-3-3, EN300328, EN301489-01, EN301489-17 e EN50385.
La déclaration de conformité pourra être consultée auprès de notre représentant en Europe, DENON Europe.

DICHIARAZIONE DI CONFORMITÀ

Con la presente D&M Holdings Inc., Denon Brand Company dichiara che questo AVR-4810 è conforme ai requisiti essenziali ed alle altre disposizioni pertinenti stabilite dalla direttiva 1999/5/CE, e conforme alle seguenti normative:
EN60065, EN55013, EN55020, EN55022, EN55024, EN61000-3-2, EN61000-3-3, EN300328, EN301489-01, EN301489-17 e EN50385.
La dichiarazione di conformità può essere consultata presso il nostro rappresentante europeo, DENON Europe.
QUESTO PRODOTTO E' CONFORME AL D.M. 28/08/95 N. 548

DECLARACIÓN DE CONFORMIDAD

Por la presente, D&M Holdings Inc., Denon Brand Company, declara que este AVR-4810 cumple con los requisitos esenciales y otras exigencias relevantes de la Directiva 1999/5/EC, esta conforme con los siguientes estandares:
EN60065, EN55013, EN55020, EN55022, EN55024, EN61000-3-2, EN61000-3-3, EN300328, EN301489-01, EN301489-17 y EN50385.
Puede consultar a nuestro representante europeo, DENON Europe, acerca de la declaración de conformidad.

EENVORMIGHEIDSVERKLARING





Hierbij verklaart D&M Holdings Inc., Denon Brand Company dat het toestel AVR-4810 in overeenstemming is met de essentiële eisen en de andere relevante bepalingen van richtlijn 1999/5/EG, in overeenstemming is met de volgende normen:
EN60065, EN55013, EN55020, EN55022, EN55024, EN61000-3-2, EN61000-3-3, EN300328, EN301489-01, EN301489-17 en EN50385.
De eenvormigheidsverklaring mag worden geconsulteerd aan onze Europese vertegenwoordiger, DENON Europe.

ÖVERENSSTÄMMELSEINTYG

Denna utrustning är i överensstämmelse med de väsentliga kraven och andra relevanta bestämmelser i Direktiv 1999/5/EC, uppfyller följande standarder:
EN60065, EN55013, EN55020, EN55022, EN55024, EN61000-3-2, EN61000-3-3, EN300328, EN301489-01, EN301489-17 och EN50385.
EU-konformitetsintyget kan på begäran fås från DENON Europe, vår representant i Europe.

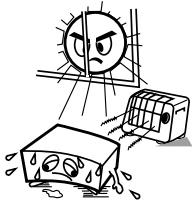
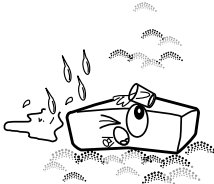
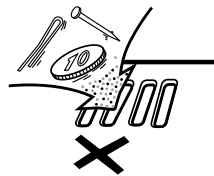
DENON EUROPE
Division of D&M Germany GmbH
An der Kleinbahn 18, Nettetal,
D-41334 Germany

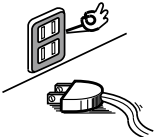
NOTE ON USE / HINWEISE ZUM GEBRAUCH / OBSERVATIONS RELATIVES A L'UTILISATION / NOTE SULL'USO / NOTAS SOBRE EL USO / ALVORENSTE GEBRUIKEN / OBSERVERA ANGÅENDE ANVÄNDNINGEN

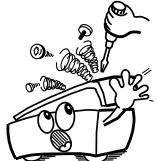
 <ul style="list-style-type: none"> • Avoid high temperatures. Allow for sufficient heat dispersion when installed in a rack. • Vermeiden Sie hohe Temperaturen. Beachten Sie, dass eine ausreichende Belüftung gewährleistet wird, wenn das Gerät auf ein Regal gestellt wird. • Eviter des températures élevées. Tenir compte d'une dispersion de chaleur suffisante lors de l'installation sur une étagère. • Evitate di esporre l'unità a temperature elevate. Assicuratevi che vi sia un'adeguata dispersione del calore quando installate l'unità in un mobile per componenti audio. • Evite altas temperaturas. Permite la suficiente dispersión del calor cuando está instalado en la consola. • Vermijd hoge temperaturen. Zorg er bij installatie in een audiorack voor, dat de door het toestel geproduceerde warmte goed kan worden afgevoerd. • Undvik höga temperaturer. Se till att det finns möjlighet till god värmeavledning vid monteringen i ett rack. 	 <ul style="list-style-type: none"> • Keep the unit free from moisture, water, and dust. • Halten Sie das Gerät von Feuchtigkeit, Wasser und Staub fern. • Protéger l'appareil contre l'humidité, l'eau et la poussière. • Tenete l'unità lontana dall'umidità, dall'acqua e dalla polvere. • Mantenga el equipo libre de humedad, agua y polvo. • Laat geen vochtigheid, water of stof in het apparaat binnendringen. • Utsätt inte apparaten för fukt, vatten och damm. 	 <ul style="list-style-type: none"> • Do not let foreign objects into the unit. • Lassen Sie keine fremden Gegenstände in das Gerät kommen. • Ne pas laisser des objets étrangers dans l'appareil. • Non inserite corpi estranei all'interno dell'unità. • No deje objetos extraños dentro del equipo. • Laat geen vreemde voorwerpen in dit apparaat vallen. • Se till att främmande föremål inte tränger in i apparaten. 	<p>CAUTION:</p> <ul style="list-style-type: none"> • The ventilation should not be impeded by covering the ventilation openings with items, such as newspapers, tablecloths, curtains, etc. • No naked flame sources, such as lighted candles, should be placed on the unit. • Observe and follow local regulations regarding battery disposal. • Do not expose the unit to dripping or splashing fluids. • Do not place objects filled with liquids, such as vases, on the unit. <p>ACHTUNG:</p> <ul style="list-style-type: none"> • Die Belüftung sollte auf keinen Fall durch das Abdecken der Belüftungsöffnungen durch Gegenstände wie beispielsweise Zeitungen, Tischtücher, Vorhänge o. Ä. behindert werden. • Auf dem Gerät sollten keinerlei direkte Feuerquellen wie beispielsweise angezündete Kerzen aufgestellt werden. • Bitte beachten Sie bei der Entsorgung der Batterien die örtlich geltenden Umweltbestimmungen. • Das Gerät sollte keiner tropfenden oder spritzenden Flüssigkeit ausgesetzt werden. • Auf dem Gerät sollten keine mit Flüssigkeit gefüllten Behälter wie beispielsweise Vasen aufgestellt werden.
 <ul style="list-style-type: none"> • Handle the power cord carefully. Hold the plug when unplugging the cord. • Gehen Sie vorsichtig mit dem Netzkabel um. Halten Sie das Kabel am Stecker, wenn Sie den Stecker herausziehen. • Manipuler le cordon d'alimentation avec précaution. Tenir la prise lors du débranchement du cordon. • Maneggiare il cavo di alimentazione con attenzione. Tenete ferma la spina quando scollegate il cavo dalla presa. • Maneje el cordón de energía con cuidado. Sostenga el enchufe cuando desconecte el cordón de energía. • Hanteer het netsnoer voorzichtig. Houd het snoer bij de stekker vast wanneer deze moet worden aan- of losgekoppeld. • Hantera nätkablen varsamt. Håll i kablarna när den kopplas från el-uttaget. 	 <ul style="list-style-type: none"> • Unplug the power cord when not using the unit for long periods of time. • Wenn das Gerät längere Zeit nicht verwendet werden soll, trennen Sie das Netzkabel vom Netzstecker. • Débrancher le cordon d'alimentation lorsque l'appareil n'est pas utilisé pendant de longues périodes. • Scollegate il cavo di alimentazione quando prevedete di non utilizzare l'unità per un lungo periodo di tempo. • Desconecte el cordón de energía cuando no utilice el equipo por mucho tiempo. • Neem altijd het netsnoer uit het stopcontact wanneer het apparaat gedurende een lange periode niet wordt gebruikt. • Koppla loss nätkablen om apparaten inte kommer att användas i lång tid. 	 <ul style="list-style-type: none"> • Do not let insecticides, benzene, and thinner come in contact with the unit. • Lassen Sie das Gerät nicht mit Insektiziden, Benzin oder Verdünnungsmitteln in Berührung kommen. • Ne pas mettre en contact des insecticides, du benzène et un diluant avec l'appareil. • Assicuratevi che l'unità non entri in contatto con insetticidi, benzolo o solventi. • No permita el contacto de insecticidas, gasolina y diluyentes con el equipo. • Voorkom dat insecticiden, benzeen of verfverdunder met dit toestel in contact komen. • Se till att inte insektsmedel på spraybruk, bensen och thinner kommer i kontakt med apparatens hölje. 	<p>ATTENTION:</p> <ul style="list-style-type: none"> • La ventilation ne doit pas être gênée en recouvrant les ouvertures de la ventilation avec des objets tels que journaux, rideaux, tissus, etc. • Aucune flamme nue, par exemple une bougie, ne doit être placée sur l'appareil. • Veillez à respecter les lois en vigueur lorsque vous jetez les piles usagées. • L'appareil ne doit pas être exposé à l'eau ou à l'humidité. • Ne pas poser d'objet contenant du liquide, par exemple un vase, sur l'appareil. <p>ATTENZIONE:</p> <ul style="list-style-type: none"> • Le aperture di ventilazione non devono essere ostruite coprendole con oggetti, quali giornali, tovaglie, tende e così via. • Non posizionate sull'unità fiamme libere, come ad esempio candele accese. • Prestate attenzione agli aspetti legati alla tutela dell'ambiente nello smaltimento delle batterie. • L'apparecchiatura non deve essere esposta a gocciolii o spruzzi. • Non posizionate sull'unità alcun oggetto contenente liquidi, come ad esempio i vasi. <p>PRECAUCIÓN:</p> <ul style="list-style-type: none"> • La ventilación no debe quedar obstruida por haberse cubierto las aperturas con objetos como periódicos, manteles, cortinas, etc. • No debe colocarse sobre el aparato ninguna fuente inflamable sin protección, como velas encendidas. • A la hora de deshacerse de las pilas, respete la normativa para el cuidado del medio ambiente. • No exponer el aparato al goteo o salpicaduras cuando se utilice. • No colocar sobre el aparato objetos llenos de líquido, como jarras.
	 <p>* (For apparatuses with ventilation holes)</p> <ul style="list-style-type: none"> • Do not obstruct the ventilation holes. • Decken Sie den Lüftungsbereich nicht ab. • Ne pas obstruer les trous d'aération. • Non coprite i fori di ventilazione. • No obstruya los orificios de ventilación. • De ventilatieopeningen mogen niet worden geblokkeerd. • Täpp inte till ventilationsöppningarna. 	 <ul style="list-style-type: none"> • Never disassemble or modify the unit in any way. • Versuchen Sie niemals das Gerät auseinander zu nehmen oder zu verändern. • Ne jamais démonter ou modifier l'appareil d'une manière ou d'une autre. • Non smontate né modificate l'unità in alcun modo. • Nunca desarme o modifique el equipo de ninguna manera. • Dit toestel mag niet gedemonteerd of aangepast worden. • Ta inte isär apparaten och försök inte bygga om den. 	<p>WAARSCHUWING:</p> <ul style="list-style-type: none"> • De ventilatie mag niet worden belemmerd door de ventilatieopeningen af te decken met bijvoorbeeld kranten, een tafelkleed, gordijnen, enz. • Plaats geen open vlammen, bijvoorbeeld een brandende kaars, op het apparaat. • Houd u steeds aan de milieuvorschriften wanneer u gebruikte batterijen wegdoet. • Stel het apparaat niet bloot aan druppels of spatten. • Plaats geen voorwerpen gevuld met water, bijvoorbeeld een vaas, op het apparaat. <p>OBSERVERA:</p> <ul style="list-style-type: none"> • Ventilationen bör inte förhindras genom att täcka för ventilationsöppningarna med föremål såsom tidningar, bordsdukar, gardiner osv. • Inga blottade brandkällor, såsom tända ljus, får placeras på apparaten. • Tänk på miljöaspekterna när du bortskaffar batterier. • Apparaten får inte utsättas för vätska. • Placera inte föremål fyllda med vätska, t.ex. vaser, på apparaten.

A NOTE ABOUT RECYCLING:

This product's packaging materials are recyclable and can be reused. Please dispose of any materials in accordance with the local recycling regulations.

When discarding the unit, comply with local rules or regulations.

Batteries should never be thrown away or incinerated but disposed of in accordance with the local regulations concerning battery disposal.

This product and the supplied accessories, excluding the batteries, constitute the applicable product according to the WEEE directive.

HINWEIS ZUM RECYCLING:

Das Verpackungsmaterial dieses Produktes ist zum Recyceln geeignet und kann wieder verwendet werden. Bitte entsorgen Sie alle Materialien entsprechend der örtlichen Recycling-Vorschriften.

Beachten Sie bei der Entsorgung des Gerätes die örtlichen Vorschriften und Bestimmungen.

Die Batterien dürfen nicht in den Hausmüll geworfen oder verbrannt werden; bitte entsorgen Sie die Batterien gemäß der örtlichen Vorschriften.

Dieses Produkt und das im Lieferumfang enthaltene Zubehör (mit Ausnahme der Batterien!) entsprechen der WEEE-Direktive.

UNE REMARQUE CONCERNANT LE RECYCLAGE:

Les matériaux d'emballage de ce produit sont recyclables et peuvent être réutilisés. Veuillez disposer des matériaux conformément aux lois sur le recyclage en vigueur.

Lorsque vous mettez cet appareil au rebut, respectez les lois ou réglementations en vigueur.

Les piles ne doivent jamais être jetées ou incinérées, mais mises au rebut conformément aux lois en vigueur sur la mise au rebut des piles.

Ce produit et les accessoires inclus, à l'exception des piles, sont des produits conformes à la directive DEEE.

NOTA RELATIVA AL RICICLAGGIO:

I materiali di imballaggio di questo prodotto sono riutilizzabili e riciclabili. Smaltire i materiali conformemente alle normative locali sul riciclaggio.

Per lo smaltimento dell'unità, osservare le normative o le leggi locali in vigore.

Non gettare le batterie, né incenerirle, ma smaltirle conformemente alla normativa locale sui rifiuti chimici.

Questo prodotto e gli accessori inclusi nell'imballaggio sono applicabili alla direttiva RAEE, ad eccezione delle batterie.

ACERCA DEL RECICLAJE:

Los materiales de embalaje de este producto son reciclables y se pueden volver a utilizar. Disponga de estos materiales siguiendo los reglamentos de reciclaje de su localidad.

Cuando se deshaga de la unidad, cumpla con las reglas o reglamentos locales.

Las pilas nunca deberán tirarse ni incinerarse. Deberá disponer de ellas siguiendo los reglamentos de su localidad relacionados con los desperdicios químicos.

Este producto junto con los accesorios empaquetados es el producto aplicable a la directiva RAEE excepto pilas.

EEN AANTEKENING MET BETREKKING TOT DE RECYCLING:

Het inpakmateriaal van dit product is recycleerbaar en kan opnieuw gebruikt worden. Er wordt verzocht om zich van elk afvalmateriaal te ontdoen volgens de plaatselijke voorschriften.

Volg voor het wegdoen van de speler de voorschriften voor de verwijdering van wit- en bruingoed op.

Batterijen mogen nooit worden weggegooid of verbrand, maar moeten volgens de plaatselijke voorschriften betreffende chemisch afval worden verwijderd.

Op dit product en de meegeleverde accessoires, m.u.v. de batterijen is de richtlijn voor afgedankte elektrische en elektronische apparaten (WEEE) van toepassing.

OBSERVERA ANGÅENDE ÅTERTVINNING:

Produktens emballage är återvinningsbart och kan återanvändas. Kassera det enligt lokala återvinningsbestämmelser.

När du kasserar enheten ska du göra det i överensstämmelse med lokala regler och bestämmelser.

Batterier får absolut inte kastas i soporna eller brännas. Kassera dem enligt lokala bestämmelser för kemiskt avfall.

Denna apparat och de tillbehör som levereras med den uppfyller gällande WEEE-direktiv, med undantag av batterierna.



Pb

1. IMPORTANT NOTICE: DO NOT MODIFY THIS PRODUCT

This product, when installed as indicated in the instructions contained in this manual, meets R&TTE directive requirements. Modification of the product could result in hazardous Radio and EMC radiation.

2. CAUTION

- Separation distance of at least 20 cm must be maintained between the antenna of this product and all persons.
- This product and its antenna must not be co-located or operating in conjunction with any other antenna or transmitter.

1. WICHTIGER HINWEIS: NEHMEN SIE KEINE VERÄNDERUNGEN AN DIESEM PRODUKT VOR

Wenn dieses Produkt entsprechend dieser Bedienungsanleitung aufgebaut wird, entspricht es den Anforderungen der R&TTE-Richtlinie. Veränderungen am Produkt können zu gefährlicher Funk- und EMV-Strahlung führen.

2. VORSICHT

- Zwischen der Antenne dieses Produkts und Personen muss ein Schutzabstand von 20 cm eingehalten werden.
- Dieses Produkt und seine Antenne dürfen nicht neben anderen Antennen oder Sendern aufgestellt oder zusammen mit ihnen verwendet werden.

1. MISE EN GARDE IMPORTANTE : NE JAMAIS MODIFIER CE PRODUIT

Si toutes les consignes indiquées dans ce mode ont été respectées pendant son installation, ce produit est conforme aux directives R&TTE. Toute modification du produit risquerait alors de générer des radiations radio et EMC dangereuses.

2. ATTENTION

- L'antenne de l'appareil devra être située à une distance de 20 cm au moins des personnes.
- Ce produit ainsi que son antenne ne devront en aucun cas être utilisés à proximité d'une autre antenne ou transmetteur.

1. AVVERTENZA IMPORTANTE: NON MODIFICARE QUESTO PRODOTTO

Se installato come indicato nelle istruzioni del presente manuale, questo prodotto soddisfa i requisiti della direttiva R&TTE. Eventuali modifiche apportate al prodotto potrebbero causare pericolose radiazioni radio ed EMC.

2. ATTENZIONE

- È necessario mantenere una distanza minima di 20 cm tra l'antenna di questo prodotto e le persone.
- Questo prodotto e la relativa antenna non devono essere posizionati in prossimità di altre antenne o trasmettitori e non devono essere utilizzati congiuntamente a questi ultimi.

1. NOTA IMPORTANTE: NO MODIFIQUE ESTE PRODUCTO

Este producto, si es instalado de acuerdo con las instrucciones contenidas en este manual, cumple los requisitos de la directiva R&TTE. La modificación del producto puede producir radiación de Radio y EMC peligrosa.

2. PRECAUCIÓN

- Se debe mantener una separación de al menos 20 cm entre la antena del producto y las personas.
- Este producto y su antena no debe instalarse ni utilizarse conjuntamente con otra antena o transmisor.

1. BELANGRIJKE MEDEDELING: BRENG AAN DIT PRODUCT GEEN AANPASSINGEN AAN

Dit product, indien geïnstalleerd volgens de aanwijzingen in deze gebruiksaanwijzing, voldoet aan de vereisten van de R&TTE-richtlijn. Aanpassing van dit product kan gevaarlijke radio- en EMC-straling tot gevolg hebben.

2. LET OP

- Houd tussen antenne en personen altijd een afstand van tenminste 20 cm aan.
- Dit product en zijn antenne mogen niet in de buurt van een andere antenne of zender worden geplaatst of in combinatie daarmee worden gebruikt.

1. VIKTIGT: APPARATEN FÅR INTE MODIFIERAS

Under förutsättning att apparaten installeras enligt anvisningarna i denna bruksanvisning, uppfyller denna kraven i R&TTE-direktivet. Ev. modifiering av apparaten kan resultera i farlig radio- och elektromagnetisk strålning.

2. FÖRSIKTIGT

- Se till att det finns ett avstånd på minst 20 cm mellan apparatens antenn och personer i omgivningen.
- Apparaten och dess antenn får inte placeras eller användas i närheten av andra antenner eller sändare.

□ Contents

Getting Started	2	Playback	64	Checking the Status (Information)	87
Flow of Operations Through Playback	2	Important Information	64	Other Operations and Convenient Functions	88
Cautions on Handling	2	Playing Components	64	Other Operations	88
Cautions on Installation	2	Playing a Blu-ray Disc Player/DVD Player.....	64	Playing a Blu-ray Disc Player Compatible	
Preparations	3	Playing an iPod® Using a Control Dock for iPod.....	64	with DENON LINK 4th.....	88
Accessories.....	3	Playing an iPod® Connected Directly to the AVR-4810's		Playing Super Audio CD.....	89
About the Remote Control Unit.....	3	USB Port.....	66	Recording on an External Device (REC OUT mode).....	89
Part Names and Functions	4	Tuning in Radio Stations	67	Convenient Functions	90
Front Panel.....	4	Listening to FM/AM Broadcasts.....	67	HDMI Control Function.....	90
Display.....	5	RDS (Radio Data System).....	68	Setting the Power to Standby After a Certain Amount of Time	
Rear Panel.....	6	RDS Search.....	69	(Sleep Timer Function).....	91
Remote Control Unit.....	7	PTY Search.....	69	Adjust the Volume of the Speakers.....	91
		TP Search.....	69	Saving Frequently Used Settings (Quick Select Function).....	91
		RT (Radio Text).....	69	Playing the Same Network Audio on Different Devices	
		Playing Network Audio, USB Memory Devices	69	Connected in a Network (Party Mode Function).....	92
Connections	9	Listening to Internet Radio.....	71	Operating a Wireless LAN-Compatible Mobile Terminal to Play	
Important Information	9	Playing Files Stored on a Computer.....	73	Music and Still Pictures.....	93
Cables Used for Connections.....	9	Playing Files Stored on USB Memory Devices.....	74	Operating the AVR-4810 with a Browser	
Converting Input Video Signals for Output		Listening to Napster.....	75	(Web Control Function).....	94
(Video Conversion Function).....	10	Operations During Playback	76	Various Memory Functions.....	95
Installing the Speakers	11	Adjusting the Master Volume.....	76		
Speaker Connections	14	Turning Off the Sound Temporarily (Muting).....	76		
Connecting Devices	17	Listening with Headphones.....	76		
Connecting the Power Cord	27	To Stop.....	76		
Once Connections are Completed	27	Stopping Playback Temporarily.....	76		
Turning the Power On.....	27	Fast-forwarding or Fast-reversing.....	76		
Turning the Power Off.....	27	To Cue to the Beginning of a Track.....	76		
		Playing Repeatedly.....	77		
		Selecting Tracks.....	77		
Settings	28	Shuffling Playback.....	77		
GUI Menu Map	28	Playing in Random Order.....	77		
GUI Menu Operation	29	Searching Pages.....	77		
Example of the Display of the GUI Mark at a Title.....	29	Searching by First Letter.....	77		
Examples of GUI Menu Screen Displays.....	29	Selecting the Surround Mode (Surround Mode)	78		
Selecting the Input Source.....	30	Adjusting the Sound and Picture Quality			
Make the Optimal Speaker Settings, and Correct the Room		(Audio/Video Adjust).....	81		
Acoustics (Audyssey™ Auto Setup)	31	Adjusting the Sound (Audio Adjust).....	81		
Making Detailed Settings (Manual Setup)	38	Adjusting the Picture Quality (Picture Adjust).....	86		
Making the Input Settings (Source Select)	56				

Operating the Connected Devices by Remote Control Unit99

Operating the Main Remote Control Unit99

Operating AV Equipment99

Presetting100

Operating Preset Components101

Setting the Remote ID104

Learning Function104

MACRO Function105

Punch Through Function106

Setting the Time the Backlight Stays Lit106

Adjusting the Backlight's Brightness106

Specifying the Zone Used with the Main Remote Control Unit107

Resetting the Main Remote Control Unit107

Operating the Sub Remote Control Unit108

Switching Zones109

Switching the Multi-zone Input Source to the Same Input Source as Used in the MAIN ZONE109

Setting the Zone for Which the Sub Remote Control Unit is Used (ZONE SELECT LOCK Mode)109

Setting the Remote ID109

Resetting the Settings109

Other Information110

Troubleshooting120

Restoring All the Settings to as They were at the Time of Purchase (Resetting the Microprocessor)123

Specifications124

List of preset codesEnd of this manual

Getting Started

Flow of Operations Through Playback

Perform the operations leading to playback on the AVR-4810 in the order shown below.

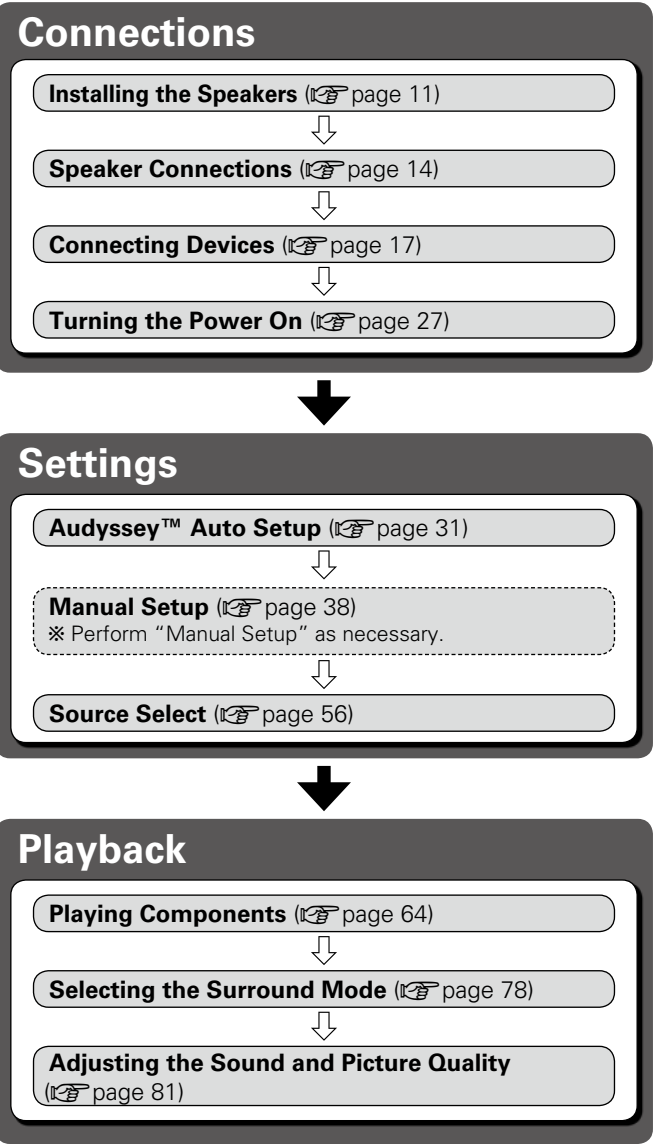

Cautions on Handling

- **Before turning the power switch on**
Check once again that all connections are correct and that there are no problems with the connection cables.
- Power is supplied to some of the circuitry even when the unit is set to the standby mode. When traveling or leaving home for long periods of time, be sure to unplug the power cord from the power outlet.
- **About condensation**
If there is a major difference in temperature between the inside of the unit and the surroundings, condensation (dew) may form on the operating parts inside the unit, causing the unit not to operate properly.
If this happens, let the unit sit for an hour or two with the power turned off and wait until there is little difference in temperature before using the unit.
- **Cautions on using mobile phones**
Using a mobile phone near this unit may result in noise. If so, move the mobile phone away from this unit when it is in use.
- **Moving the unit**
Turn off the power and unplug the power cord from the power outlet.
Next, disconnect the connection cables to other system units before moving the unit.
- Note that the illustrations in these instructions may differ from the actual unit for explanation purposes.

Cautions on Installation

Note:
For proper heat dispersal, do not install this unit in a confined space, such as a bookcase or similar enclosure.

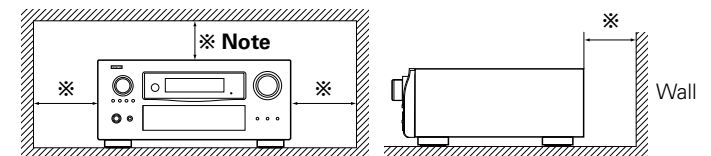

Preparations

Thank you for purchasing this DENON product. To ensure proper operation, please read this owner's manual carefully before using the product.

After reading them, be sure to keep them for future reference.

Accessories

Check that the following parts are supplied with the product.

① Owner's manual	1
② Getting started	1
③ Service station list	1
④ Power cord (Cord length: Approx. 1.9 m)	1
⑤ Main remote control unit (RC-1126)	1
⑥ LR6/AA batteries (for RC-1126)	2
⑦ Sub remote control unit (RC-1121)	1
⑧ R03/AAA batteries (for RC-1121)	2
⑨ FM indoor antenna	1
⑩ AM loop antenna	1
⑪ Rod antenna for wireless LAN connection	1
⑫ Setup microphone (DM-A409, Cord length: Approx. 7.6 m)	1

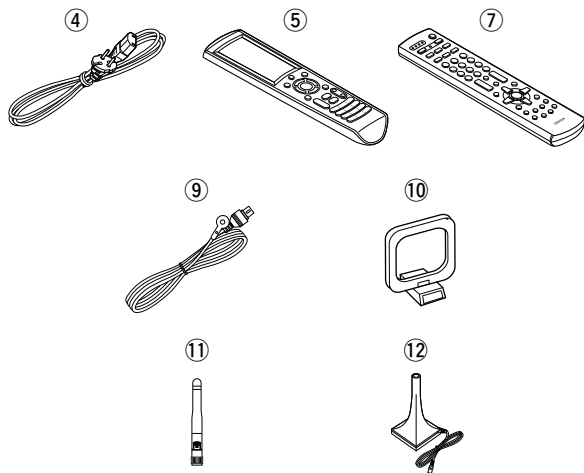

About the Remote Control Unit

In addition to the AVR-4810, the included main remote control unit (RC-1126) can also be used to operate the equipment listed below.

- ① DENON system components
- ② Non-DENON system components
 - To operate component products other than DENON, you must set the preset code (page 100 "Presetting").
 - If you are using a non-DENON AV device, or if you cannot operate the device even after registering the preset code, memorize the other device's remote control signal in the AVR-4810 remote control unit (page 104 "Learning Function").

Inserting the Batteries

- ① Lift the clasp and remove the rear lid.

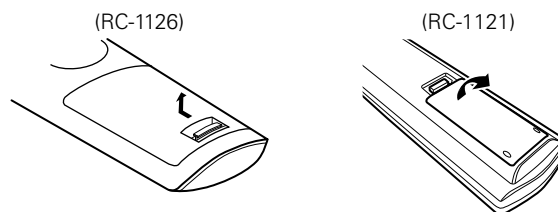

- ② Load the two batteries properly as indicated by the marks in the battery compartment.

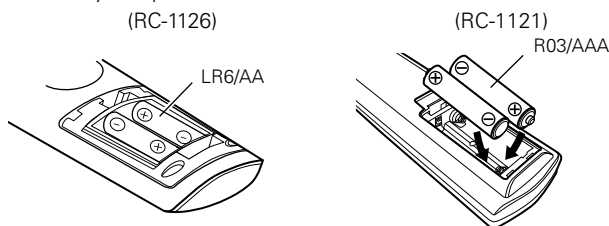

- ③ Put the rear cover back on.

NOTE

- Insert the specified batteries in the remote control unit.
- Replace the batteries with new ones if the set does not operate even when the remote control unit is operated close to the unit. (The supplied batteries are only for verifying operation.)
- When inserting the batteries, be sure to do so in the proper direction, following the "⊕" and "⊖" marks in the battery compartment.
- To prevent damage or leakage of battery fluid:
 - Do not use a new battery together with an old one.
 - Do not use two different types of batteries.
 - Do not attempt to charge dry batteries.
 - Do not short-circuit, disassemble, heat or dispose of batteries in flames.
- If the battery fluid should leak, carefully wipe the fluid off the inside of the battery compartment and insert new batteries.
- Remove the batteries from the remote control unit if it will not be in use for long periods.
- Used batteries should be disposed of in accordance with the local regulations regarding battery disposal.

Operating Range of the Remote Control Unit

Point the remote control unit at the remote sensor when operating it.

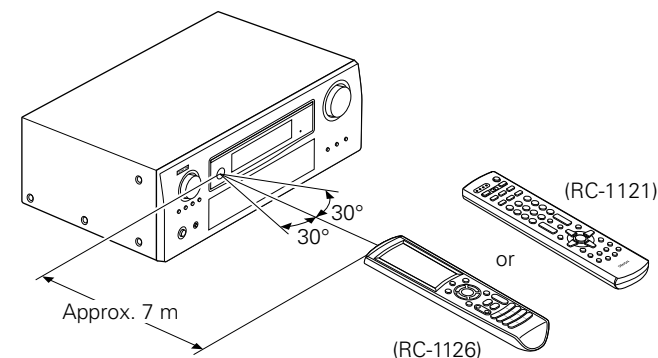

NOTE

The set may function improperly or the remote control unit may not operate if the remote control sensor is exposed to direct sunlight, strong artificial light from an inverter type fluorescent lamp or infrared light.

Part Names and Functions

Front Panel

For buttons not explained here, see the page indicated in parentheses ().

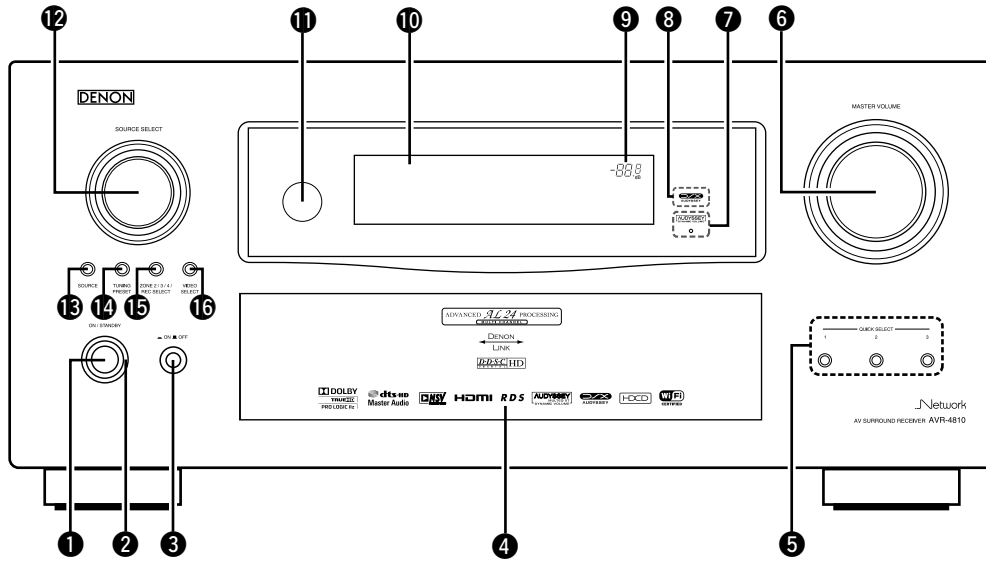

- 1 Power operation button (ON/STANDBY)** (27)
- 2 Power indicator (ON OFF)** (27)
- 3 Power switch** (27)
- 4 Door**
When you are using buttons and/or terminals behind the door, press the bottom of the door to open it. When not using buttons and/or terminals behind the door, close it. Be careful not to catch your fingers when closing the door.
- 5 QUICK SELECT buttons** (91)
- 6 MASTER VOLUME control knob** (76)
- 7 AUDYSSEY DYNAMIC VOLUME™ indicator** (84)
- 8 AUDYSSEY DSX™ indicator** (84)
- 9 Master volume indicator**
- 10 Display**
- 11 Remote control sensor** (3)
- 12 SOURCE SELECT knob** (30)
- 13 SOURCE button** (30)
- 14 TUNING PRESET button** (67)
- 15 ZONE 2/3/4 / REC SELECT button** (89, 97)
- 16 VIDEO SELECT button** (60)

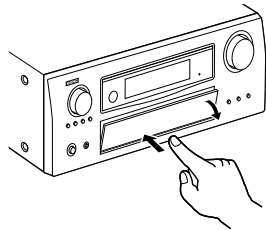

[With the door open]

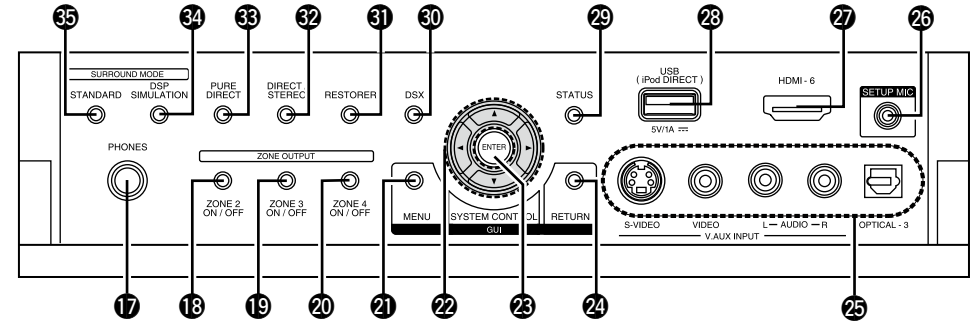

- 17 Headphones jack (PHONES)** (76)
- 18 ZONE2 ON/OFF button** (97)
- 19 ZONE3 ON/OFF button** (97)
- 20 ZONE4 ON/OFF button** (97)
- 21 MENU button** (29)
- 22 Cursor buttons (Δ ▽ ◀ ▶)** (29)
- 23 ENTER button** (29)
- 24 RETURN button** (29)
- 25 V.AUX INPUT connectors** (23)
- 26 SETUP MIC jack** (32)
- 27 HDMI IN connector** (17)
- 28 USB (iPod DIRECT) port** (23)
- 29 STATUS button** (87)
- 30 DSX button** (84)
- 31 RESTORER button** (85)
- 32 DIRECT/STEREO button** (79, 80)
- 33 PURE DIRECT button** (80)
- 34 DSP SIMULATION button** (79)
- 35 STANDARD button** (78)

Display

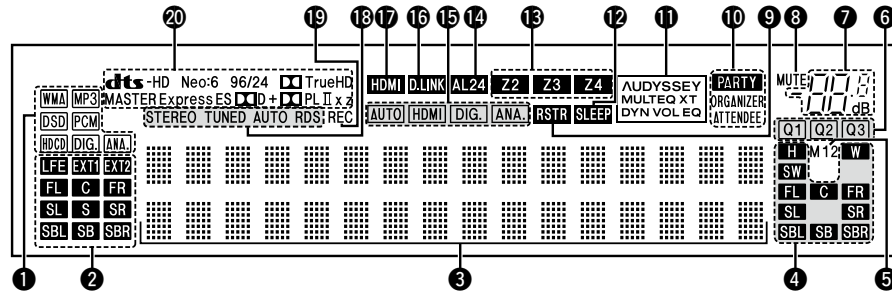

1 Input signal indicators

2 Input signal channel indicators

These light when digital signals are input. When playing HD Audio sources, the "EXT1" indicator lights when an extension channel (a channel other than the front, center, surround, surround back or LFE channel) is input. If there are two or more extension channels, the "EXT1" and "EXT2" indicators light.

3 Information display

The input source name, surround mode, setting values and other information are displayed here.

4 Output signal channel indicators

5 Monitor output indicators

These light according to the HDMI monitor output setting (page 42 "Monitor Out"). When set to "Auto (Dual)", the indicators light according to the connection status.

6 QUICK SELECT indicators

7 Master volume indicator

8 MUTE indicator

This lights when the mute mode is selected (page 76).

9 RESTORER indicator

This lights when the RESTORER mode is selected (page 85).

10 PARTY indicators

These indicators light during party mode (page 92 "Playing the Same Network Audio on Different Devices Connected in a Network (Party Mode Function)").

• ORGANIZER

This lights to indicate that party mode has started as Organizer.

• ATTENDEE

This lights to indicate that party mode has started as Attendee.

11 AUDYSSEY MULTEQ XT indicators

Lighting is as follows, depending on the setting of "Dynamic EQ" (page 83) and "Dynamic Volume" (page 84).

 : When "DynamicEQ" and "Dynamic Volume" are "ON".

 : When the "Dynamic EQ" setting is "ON" and the "Dynamic Volume" setting is "OFF".

 : When "DynamicEQ" and "Dynamic Volume" are "OFF".

12 SLEEP indicator

This lights when the sleep mode is selected (page 91).

13 Multi zone indicators

These light when the power for the respective zone is turned on.

14 Advanced AL24 indicator

This lights when Advanced AL24 Processing (page 112) or AL24 Processing Plus (page 112) is activated.

15 Input mode indicators

16 D.LINK indicator

This lights when playing using DENON LINK connections (page 89 "Playing Super Audio CD").

17 HDMI indicator

This lights when playing using HDMI connections.

18 Tuner reception mode indicators

These light according to the reception conditions when the input source is set to "TUNER".

• STEREO

In the FM mode, these light when receiving analog stereo broadcasts.

• TUNED

Lights when the broadcast is properly tuned in.

• AUTO

These light when in the auto tuning mode.

• RDS

These light when receiving RDS broadcasts.

19 Recording output source indicator

This lights when the REC OUT mode is selected (page 89).

20 Decoder indicators

These light when the respective decoders are operating.

Part Names and Functions

Rear Panel

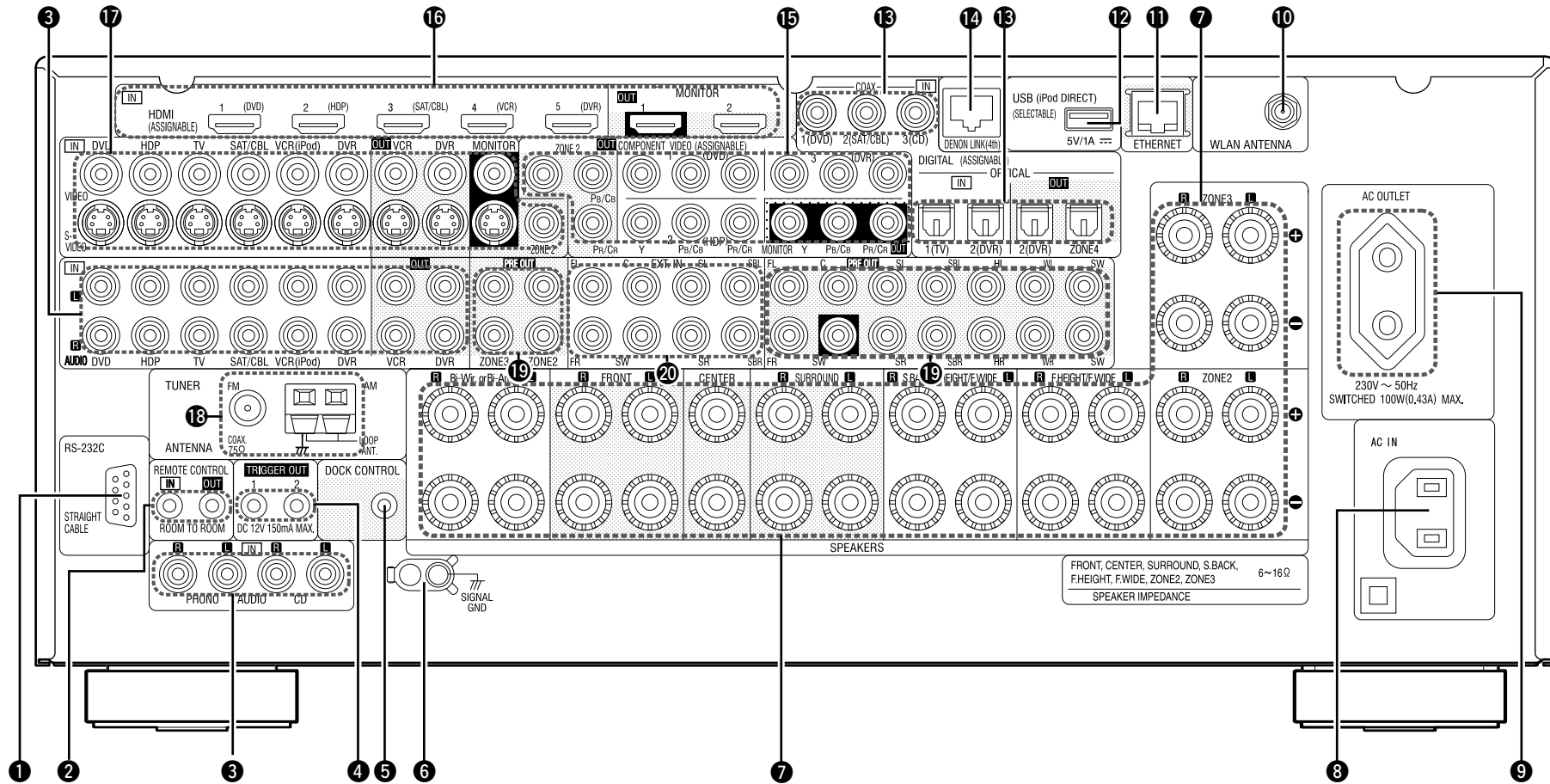

- 1 RS-232C connector (25)
- 2 REMOTE CONTROL jacks (25)
- 3 Analog audio connectors (18 ~ 21)
- 4 TRIGGER OUT jacks (25)
- 5 DOCK CONTROL jack (19)
- 6 SIGNAL GND terminal (19)
- 7 Speaker terminals (14 ~ 16)
- 8 AC inlet (27)
- 9 AC OUTLET (27)
- 10 WLAN ANTENNA terminal (26)
- 11 ETHERNET connector (25)
- 12 USB (iPod DIRECT) port (23)
- 13 Digital audio connectors (18 ~ 23)
- 14 DENON LINK connector (22)
- 15 COMPONENT VIDEO connectors (18, 20)
- 16 HDMI connectors (17)
- 17 VIDEO / S-VIDEO connectors (18 ~ 21)
- 18 FM/AM antenna terminals (22)
- 19 PRE OUT connectors (24, 96)
- 20 EXT. IN connectors (24)

Remote Control Unit

Main Remote Control Unit (RC-1126)

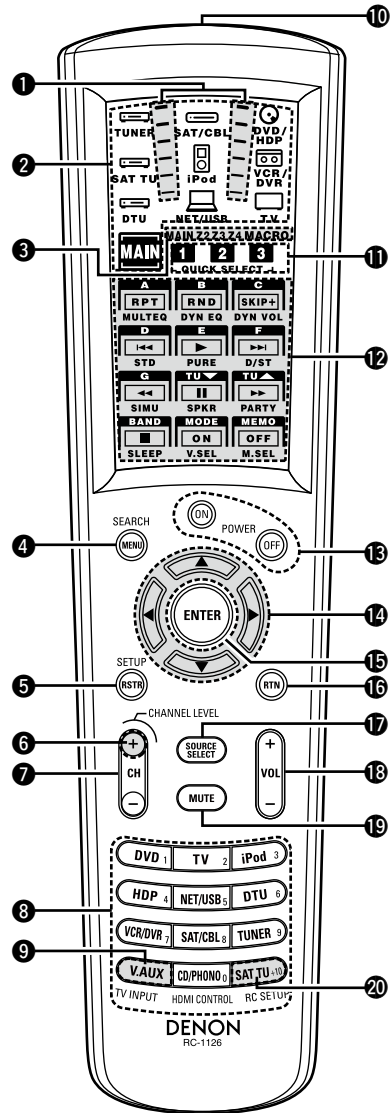

- 1 Signal transmission indicator (99)
- 2 Device select buttons (99)
- 3 Zone indicators / MACRO indicator (99)
- 4 MENU button (29)
SEARCH button (68, 77)
- 5 RESTORER button (RSTR) (85)
- 6 CHANNEL LEVEL button (91)
- 7 Channel buttons (CH) (67 ~ 69)
- 8 Input source select buttons (30)
Number buttons (67, 68, 72)
- 9 TV INPUT button (102)
- 10 Remote control signal transmitter (3)
- 11 QUICK SELECT button (91, 98)
MACRO button (105)
- 12 Function buttons
See "Operations Possible by Main Remote Control Unit" (page 7, 8) for more information.
- 13 Power operation buttons
(POWER ON / OFF) (27, 97)
- 14 Cursor buttons (Δ ∇ ◀ ▶) (29)
- 15 ENTER button (29)
- 16 Return button (RTN) (29)
- 17 SOURCE SELECT button (30)
- 18 Master volume control buttons (VOL) (76)
- 19 Muting button (MUTE) (76)
- 20 RC SETUP button (100)



The time for which the backlight stays on can be changed (page 106 "Setting the Time the Backlight Stays Lit").

NOTE

The DTU, SAT TU and HDMI CONTROL buttons cannot be used.

Operations Possible by Main Remote Control Unit

Operations on the AVR-4810

Operations on devices other than the AVR-4810

- Preset the remote control codes of the devices to be operated (page 100).
- The function button indicator changes depending on the Device select button you have selected.

Selected Device select button	Function button indicator	Button name
MAIN MAIN		21 MULTEQ® XT button (MULTEQ) (83)
		22 DSX button (SPKR) (84)
MAIN Z2		23 Sleep timer button (SLEEP) (91, 99)
		24 DYNAMIC EQ™ button (DYN EQ) (83)
MAIN Z3		25 DYNAMIC VOLUME™ button (DYN VOL) (84)
		26 Surround mode buttons (78 ~ 80)
MAIN Z4		• STANDARD button (STD)
		• PURE DIRECT button (PURE)
MAIN MACRO		• DIRECT / STEREO button (D/ST)
		• DSP SIMULATION button (SIMU)
SAT/CBL iPod DVD/HDP VCR/DVR TV		27 PARTY button (92)
		28 Monitor select button (M.SEL) (42)
		29 Video select button (V.SEL) (60)
		30 Multi-zone power buttons (97)
		• Multi-zone power on button (ON)
		• Multi-zone power off button (OFF)
		31 Device power buttons (101, 102)
		• Device power on button (ON)
		• Device power off button (OFF)
		32 System buttons (76, 101 ~ 103)
		• Repeat button (RPT)
		• Random button (RND)
		• Disc skip up button (SKIP+)
		• Skip button (I◀▶I)
		• Play button (▶)
		• Search button (◀◀ ▶▶)
		• Still / Pause button (II)
		• Stop button (■)
		33 QUICK SELECT button (91, 98)
		34 MACRO button (105)

Part Names and Functions

Selected Device select button	Function button indicator	Button name
TUNER		35 Preset Channel buttons(67, 68, 72) 36 Tuner system buttons(67 ~ 69) <ul style="list-style-type: none"> • Tuning down / Channel down button (TU ▼) • Tuning up / Channel up button (TU ▲) • FM/AM band switching button (BAND) * • Tuning mode (Auto / Manual) button (MODE) * • Preset memory button (MEMO) * : TUNER only
SAT TU		
DTU		
NET/USB		

❑ Multi-zone (ZONE2 / ZONE3 / ZONE4) operations (📖 page 96)

❑ Punch through setting (📖 page 106)

Sub Remote Control Unit (RC-1121)

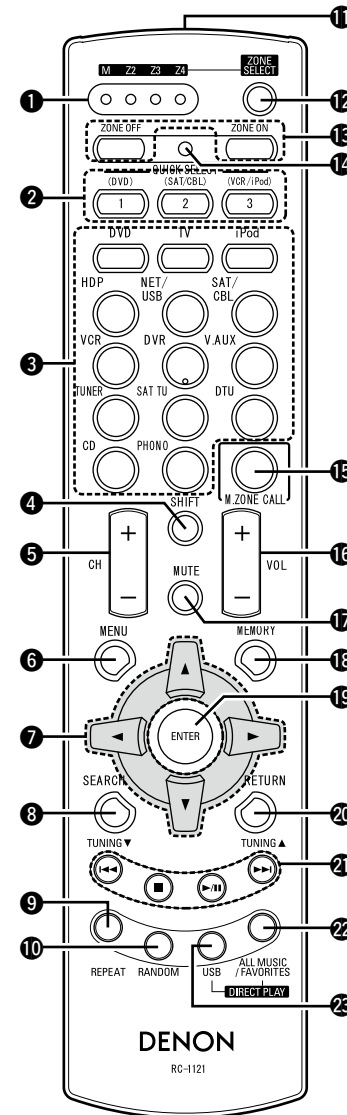

- 1** ZONE indicators (109)
- 2** QUICK SELECT buttons (91, 98)
- 3** Input source select buttons (108)
- 4** SHIFT button (67, 108)
- 5** CHANNEL button (108)
- 6** MENU button (98, 108)
- 7** Cursor buttons (▲▼◀▶) (108)
- 8** SEARCH button (77, 108)
- 9** REPEAT button (77, 108)
- 10** RANDOM button (77, 108)
- 11** Remote control signal transmitter (3)
- 12** ZONE SELECT button (109)
- 13** Zone power on/off buttons (97)
- 14** Advanced setup button (109)
- 15** MAIN ZONE call button (109)
- 16** Master volume control buttons (97)
- 17** Muting button (MUTE) (97)
- 18** MEMORY button (108)
- 19** ENTER button (108)
- 20** RETURN button (108)
- 21** System buttons (108)
- 22** ALL MUSIC/FAVORITES (DIRECT PLAY) button (108)
- 23** USB (DIRECT PLAY) button (74, 108)

NOTE

The DTU and SAT TU buttons cannot be used.

Connections

Important Information







Connections for all compatible audio and video signal formats are described in this owner's manual. Please select the types of connections suited for the equipment you are connecting. After connections are completed, certain settings must be made on the receiver. Make the settings indicated " **Set as Necessary** " for the individual items.





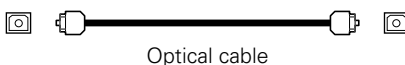

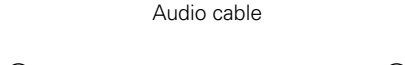
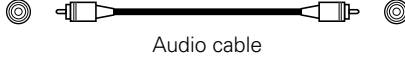
NOTE

- Do not plug in the power cord until all connections have been completed.
- When making connections, also refer to the operating instructions of the other components.
- Be sure to connect the left and right channels properly (left with left, right with right).
- Do not bundle power cords together with connection cables. Doing so can result in humming or noise.

Cables Used for Connections

Select the cables (sold separately) according to the equipment being connected.

Audio and video cables	
HDMI connections	 HDMI cable
Audio cables	
Coaxial digital connections	(Orange)  Coaxial digital cable
Optical digital connections	 Optical cable
Analog connections (stereo, surround)	(White)  (Red)  Audio cable
Analog connections (monaural, for subwoofer)	 Audio cable
Speaker connections	 Speaker cables

Video cables	
Component video connections	(Green)  (Blue)  (Red)  Component video cable
S-Video connections	 S-Video cable
Video connections	(Yellow)  Video cable
Other cables	
DENON LINK connections	 DENON LINK cable
Network connections (wired LAN)	 Ethernet cable

Important Information

Converting Input Video Signals for Output (Video Conversion Function)

The AVR-4810 has 4 different types of video input/output terminal (HDMI, Component video, S-Video, Video).

Use the terminals according to the devices to be connected.

This function automatically converts various formats of video signals input to the AVR-4810 into the format used to output the video signals from the AVR-4810 to a monitor. (☞ page 119 "Relationship Between Video Signals and Monitor Output").

[Flow of video signals for MAIN ZONE]

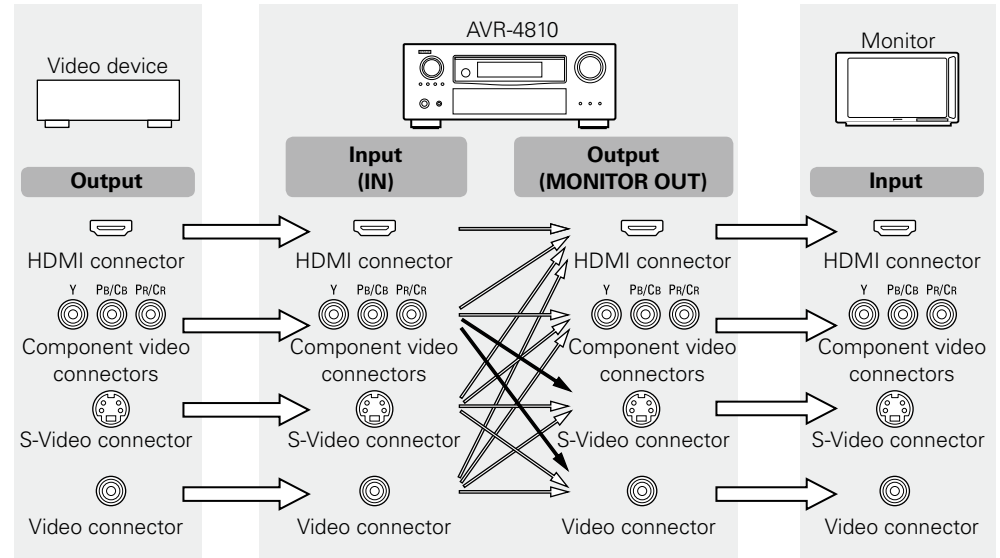

→ : When 480i/576i signals are input

[Flow of video signals for ZONE2]

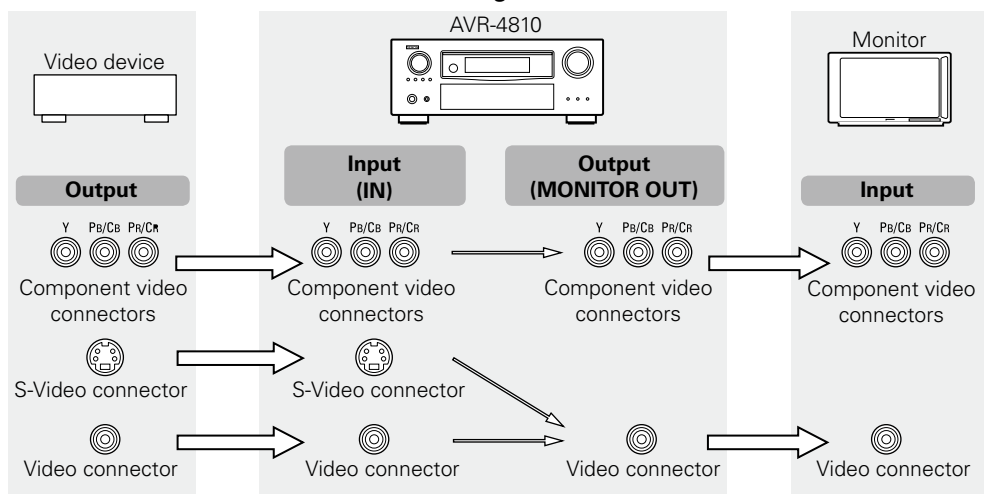

Set as Necessary

- Set when not using the video conversion function.
 - **"Video Convert"** (☞ page 60)
 - **"Resolution"** (☞ page 60)



Resolutions of HDMI-compatible TVs can be checked at "HDMI Information" – "Monitor1" or "Monitor2" (☞ page 87).

NOTE

- HDMI signals cannot be converted into analog signals.
- When a non-standard video signal from a game machine or some other source is input, the video conversion function might not operate.
- 480p/576p/1080i/720p/1080p component video input signals cannot be converted into S-Video or Video format.
- When using the component video output connectors for connection to the ZONE2 monitor, the ZONE2's on-screen display is not displayed.

Installing the Speakers

The AVR-4810 supports up to 11.1-channel surround sound playback by adding front height and front wide channels to the 7.1-channel (Front/Center/Surround/Surround Back/Subwoofer).

Installing front height and front wide speakers offers an even wider and deeper sensation compared with traditional surround spacing thanks to the advanced simulation surround technology Audyssey DSX and Dolby Pro Logic IIz decoder.

To use Audyssey DSX, install front wide or front height speakers. (Refer to page 111 for more information on Audyssey DSX)

To use Dolby Pro Logic IIz, install front height speakers. (Refer to page 110 for more information on Dolby Pro Logic IIz)

1 Speaker Layout

Below we introduce examples of speaker layouts. Refer to these to arrange your speakers according to their type and how you want to use them.

Installing All the Speakers

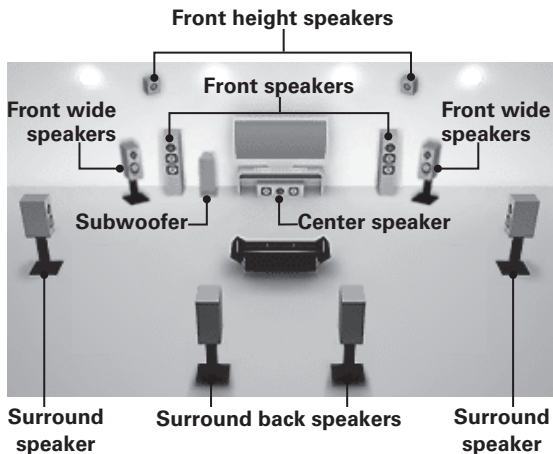

Installing the speakers

The illustration below shows the recommended speaker layout.

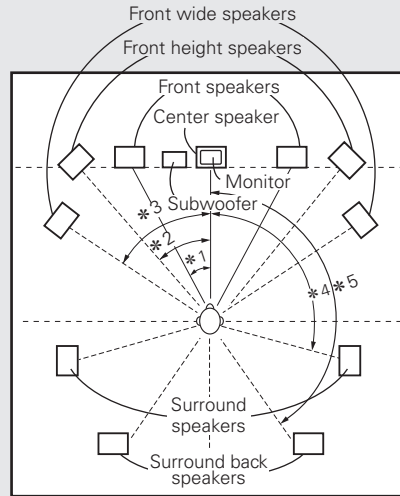

- *1: 22 ~ 30°
- *2: 22 ~ 45°
- *3: 55 ~ 60°
- *4: 90 ~ 110°
- *5: 135 ~ 150°
- *6: 45° (※2)

[As seen from above]

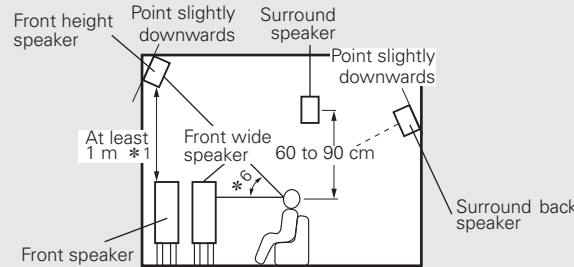

[As seen from the side]

- ※1 : Recommendation for Dolby Pro Logic IIz
- ※2 : Recommendation for Audyssey DSX

When only one surround back speaker is being used

Use the layout shown in the illustration below for the surround back speaker.

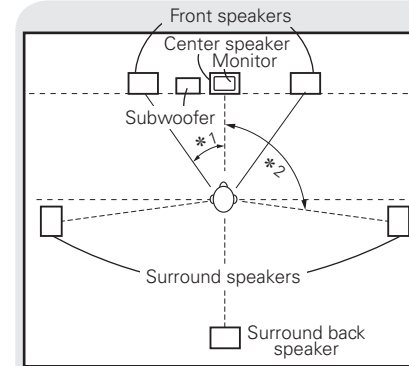

[As seen from above]

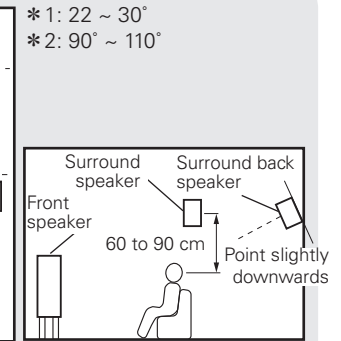

[As seen from the side]

- *1: 22 ~ 30°
- *2: 90° ~ 110°

When no surround back speaker is being used

Use the layout shown in the illustration below for the surround speaker.

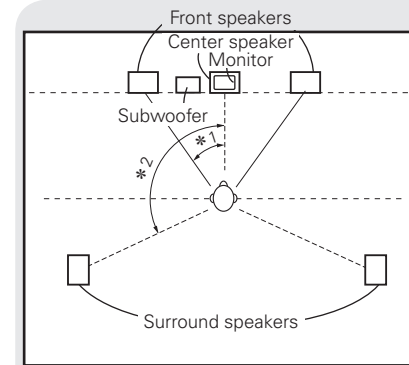

[As seen from above]

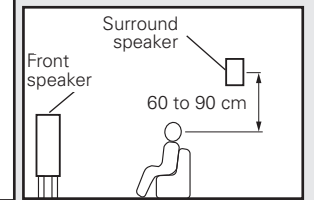

[As seen from the side]

- *1: 22 ~ 30°
- *2: 120°



Installing the Speakers



2 Example Installation of Speakers

The AVR-4810 supports a wide variation of surround playback such as in the example speaker installations shown below (11.1/9.1/7.1/6.1/5.1ch). It is also possible to have speaker output in rooms other than the room (MAIN ZONE) where the surround is playing (multi-zone playback), or to enjoy the high quality sound of the MAIN ZONE front speakers (using bi-wiring/bi-amping). Set "Amp Assign" as appropriate for the speaker system being used. See page 14 for more information on speaker connections.

Example of Speaker Installation in MAIN ZONE

(SB : Surround Back / FH : Front Height / FW : Front wide)

Speaker system	Example of speaker installation	"Amp Assign" setting (☞ page 38 ~ 40)
11.1ch • 5.1ch+SB+FH+FW	<p>MAIN ZONE</p> 	<ul style="list-style-type: none"> • Set "Configuration" to "11.1ch". ※ Use the PRE OUT terminal for the front wide channel output.
9.1ch • 5.1ch+SB+FH (Default) or • 5.1ch+SB+FW or • 5.1ch+FH+FW	<p>MAIN ZONE</p>  <p>(Example of 5.1ch+SB+FH installation)</p>	<ul style="list-style-type: none"> • Set "Configuration" to "9.1ch". • Set "Extra Channel (SB/FH/FW)" to be used.
7.1ch • 5.1ch+SB or • 5.1ch+FH or • 5.1ch+FW	<p>MAIN ZONE</p>  <p>(Example of 5.1ch+SB installation)</p>	<ul style="list-style-type: none"> • Set "Configuration" to "7.1ch". • Set "Extra Channel (SB/FH/FW)" to be used.

Speaker system	Example of speaker installation	"Amp Assign" setting (☞ page 38 ~ 40)
6.1ch • 5.1ch+SB (1 speaker)	<p>MAIN ZONE</p> 	<ul style="list-style-type: none"> • Set "Configuration" to "7.1ch". • Set "Extra Channel" to "SB". ※ Connect the surround back speaker to Lch on the S.BACK terminal. ※ In the GUI menu, set "Speaker Configuration" – "Surround Back" to "1spkr" (☞ page 40).
5.1ch	<p>MAIN ZONE</p> 	<ul style="list-style-type: none"> • Set "Configuration" to "5.1ch".

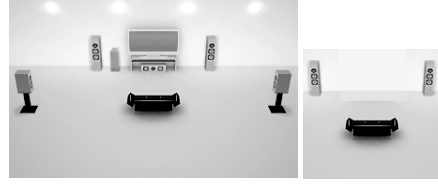
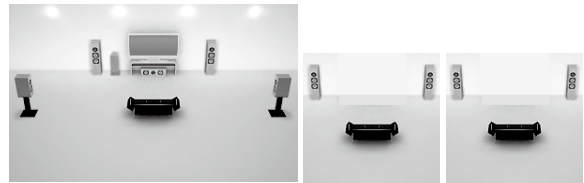

When using speaker terminals for multi-zone (ZONE2/ZONE3)

Multi-zone speaker system	Example of speaker installation	"Amp Assign" setting (☞ page 38 ~ 40)
MAIN ZONE + ZONE2	<p>MAIN ZONE ZONE2</p> 	<ul style="list-style-type: none"> • Set "Assign Mode" to "+Z2". ※ Connect speakers to the ZONE2 speaker terminals.
MAIN ZONE + ZONE2 + ZONE3	<p>MAIN ZONE ZONE2 ZONE3</p> 	<ul style="list-style-type: none"> • Set "Assign Mode" to "+Z2+Z3". ※ Connect speakers to the ZONE2 and ZONE3 speaker terminals.

When using front speakers with bi-wiring or bi-amping

Example of speaker installation	"Amp Assign" setting (☞ page 38 ~ 40)
<p>MAIN ZONE</p> 	<ul style="list-style-type: none"> • When bi-wiring : Set "Front" to "Bi-WIRING". • When bi-amp : Set "Front" to "Bi-AMP". ※ Bi-wire or bi-amp the front speakers to the front speaker terminals and Bi-Wir./Bi-Amp speaker terminals. See page 15 on how to connect.

When using different front speakers for dedicated 2-channel DIRECT/STEREO mode playback

Example of speaker installation	"Amp Assign" setting (☞ page 38 ~ 40)
<p>MAIN ZONE</p>  <p>Multi channel surround</p> <p>↔ Switching</p> <p>MAIN ZONE</p>  <p>DIRECT/STEREO</p>	<ul style="list-style-type: none"> • When bi-wiring : Set "Front" to "2CH BW". • When bi-amp : Set "Front" to "2CH BA". ※ Bi-wire or bi-amp the speakers used for dedicated 2-channel playback to the ZONE2 and ZONE3 speaker terminals.

Speaker Connections



The AVR-4810 can be connected to a maximum of three subwoofers. The same signal is output from each subwoofer terminal.

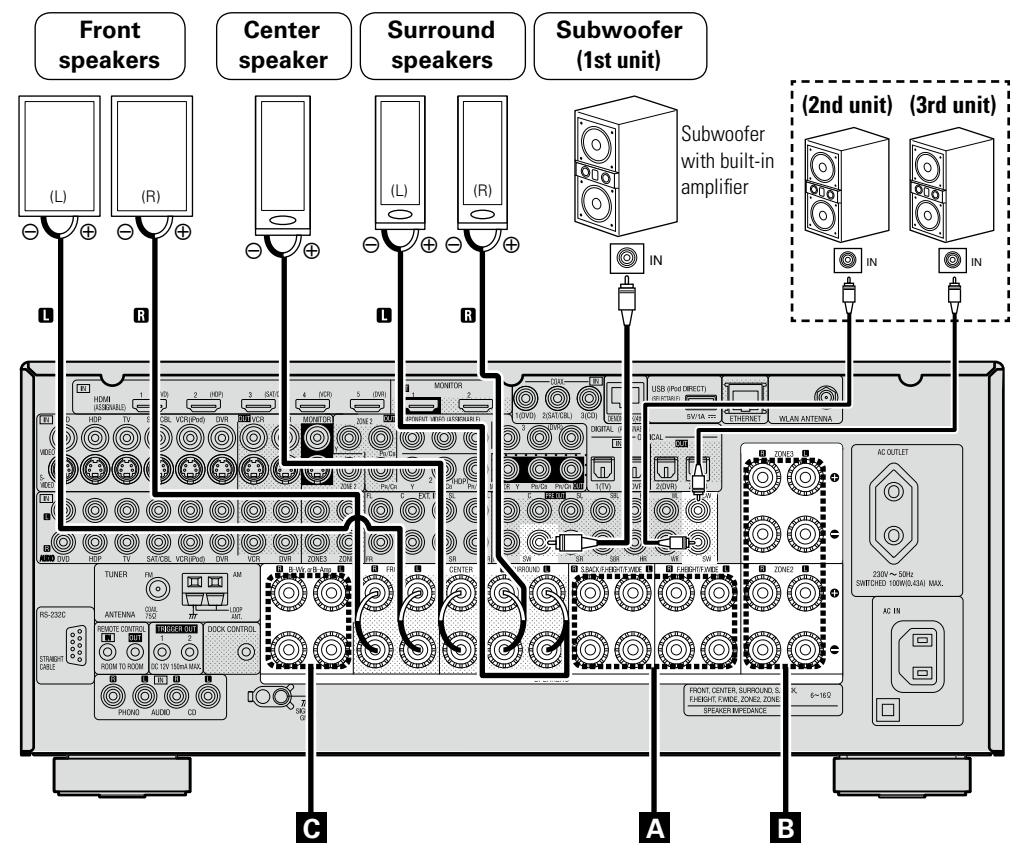

For the **A B C** speaker terminals, the output channels are different depending on the "Amp Assign" setting. Set "Amp Assign" to suit the speaker system being used and connect the speakers referring to the following chart.

A : S.BACK/F.HEIGHT/F.WIDE and F.HEIGHT/ F.WIDE speaker terminals

Use when connecting surround back speakers, front height speakers or front wide speakers.

Speaker connections

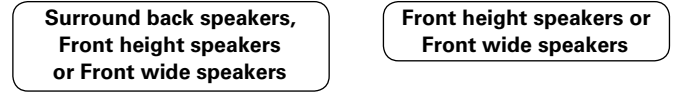

Relationship between "Amp Assign" settings and channels output by each speaker terminal

"Amp Assign" setting (page 38 ~ 40)		Channels output by each speaker terminal	
Config.	Extra Channel	S.BACK/ F.HEIGHT/ F.WIDE	F.HEIGHT/ F.WIDE
11.1ch (※)	SB/FH/FW	S.BACK	F.HEIGHT
9.1ch	SB/FW	S.BACK	F.WIDE
	SB/FH	S.BACK	F.HEIGHT
	FH/FW	F.HEIGHT	F.WIDE
7.1ch	SB	S.BACK	-
	FH	F.HEIGHT	-
	FW	F.WIDE	-
5.1ch	-	-	-

※ : Use the PRE OUT terminal for the front wide channel output.

B : ZONE2 and ZONE3 speaker terminals

Use when installing multi-zone speakers or dedicated 2-channel speakers.

① Connecting speakers for multi-zone (ZONE2/ZONE3)

□ Speaker connections

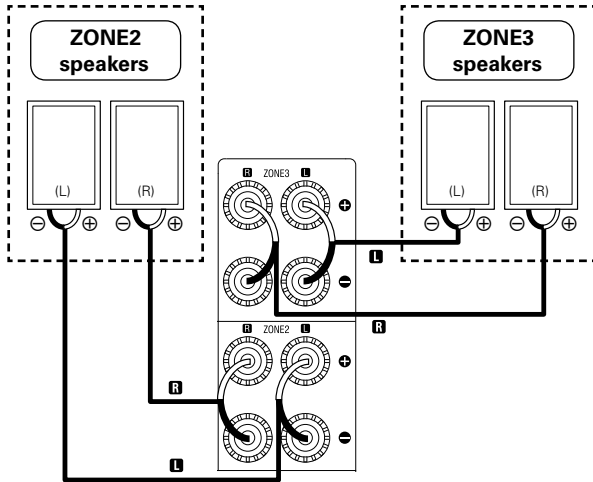

□ Relationship between "Amp Assign" settings and channels output by each speaker terminal

"Amp Assign" setting (page 38 ~ 40)	Channels output by each speaker terminal	
	ZONE2	ZONE3
Assign Mode		
+Z2	ZONE2	-
+Z2+Z3	ZONE2	ZONE3

② When front speakers for dedicated 2-channel DIRECT/STEREO mode playback are bi-wired or bi-amped

□ Speaker connections

- You can make Bi-amp or Bi-wire connections to one speaker system which supports Bi-amp or Bi-wire connection as shown below.
- Bi-amp or Bi-wire can only be used with speakers that support Bi-amp or Bi-wire. Refer to your speaker manual.

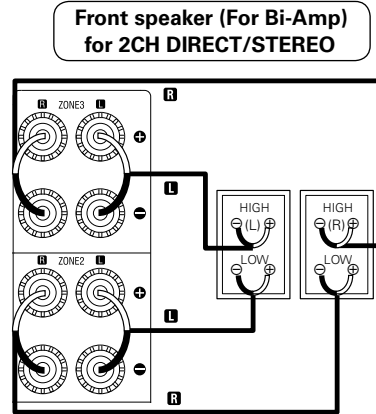

□ Relationship between "Amp Assign" settings and channels output by each speaker terminal

"Amp Assign" setting (page 38 ~ 40)	Channels output by each speaker terminal		
	Front	ZONE2	ZONE3
2CH BW ※	FRONT (2ch BW)		FRONT (2ch BW)
2CH BA ※	FRONT (2ch BA)		FRONT (2ch BA)

※ Can be selected when "Assign Mode" is "NORMAL".

C : Bi-Wir. or Bi-Amp speaker terminals

Use when front speakers are bi-wired or bi-amped.

□ Speaker connections

- You can make Bi-amp or Bi-wire connections to one speaker system which supports Bi-amp or Bi-wire connection as shown below.
- Bi-amp or Bi-wire can only be used with speakers that support Bi-amp or Bi-wire. Refer to your speaker manual.

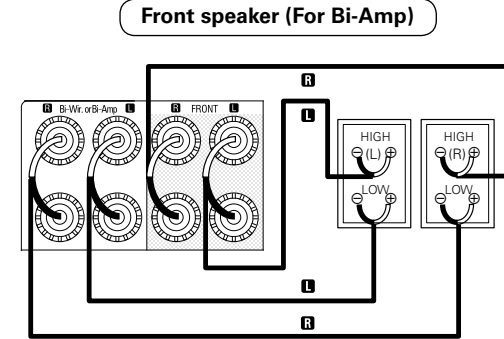

□ Relationship between "Amp Assign" settings and channels output by each speaker terminal

"Amp Assign" setting (page 38 ~ 40)	Channels output by each speaker terminal		
	Front	Bi-Wir. or Bi-Amp	FRONT
Bi-Wiring ※1		FRONT (BW)	FRONT (BW)
Bi-Amp ※2		FRONT (BA)	FRONT (BA)

※1 Can be selected when "Assign Mode" is "NORMAL", "+Z2" or "+Z2+Z3".

※2 Can be selected when "Assign Mode" is "NORMAL".

About Bi-amp Connections

These connections make for higher quality playback sound with no interference between the signals of the bass and treble units.



When making a bi-amp connection, the same signal is output from the front speaker terminal and the "Bi-Wir. or Bi-Amp" terminal.

NOTE

- Use speakers compatible with bi-amp connections.
- When making bi-amp connections, be sure to remove the short-circuiting plate or wire between the speaker's woofer and tweeter terminals.

Speaker Connections

When the "Assign Mode" is set to "ALL Z2" or "ALL Z2+Z3", only multi-zone audio is output from the AVR-4810 speaker terminals. For output in the MAIN ZONE, connect the output from the AVR-4810 pre-out terminal to an external power amp.

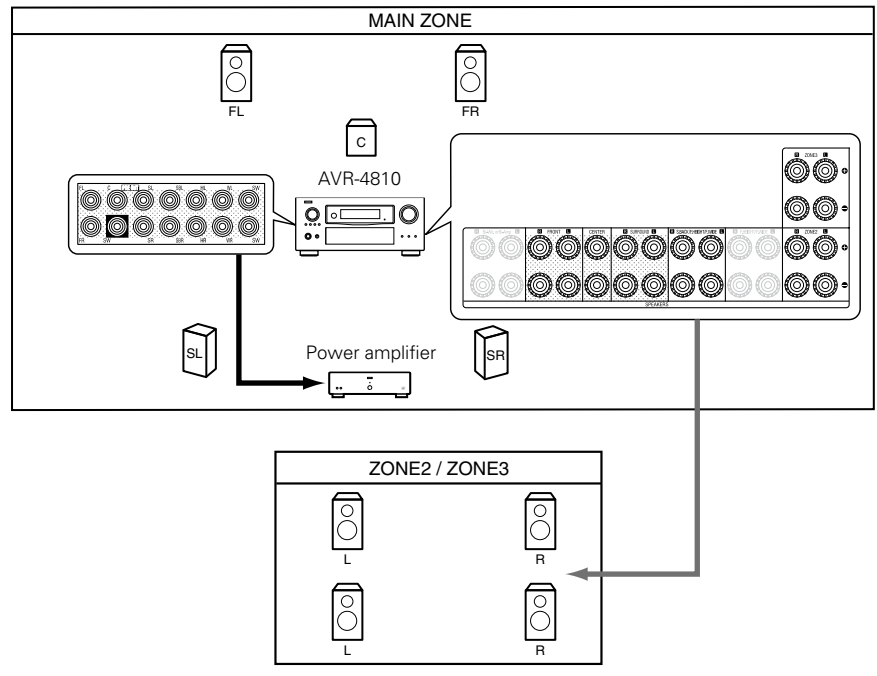

Connecting the Speaker Cables

Carefully check the left (L) and right (R) channels and + (red) and - (black) polarities on the speakers being connected to the AVR-4810, and be sure to interconnect the channels and polarities correctly.

1 Peel off about 10 mm of sheathing from the tip of the speaker cable, then either twist the core wire tightly or terminate it.



2 Turn the speaker terminal counterclockwise to loosen it.



3 Insert the speaker cable's core wire to the hilt into the speaker terminal.



4 Turn the speaker terminal clockwise to tighten it.



Use speakers where one speaker has an impedance of 6 ~ 16 Ω/ohms. When using a speaker with impedance of 6 Ω/ohms to 8 Ω/ohms, make sure to set the "Speaker Impedance" in the GUI menu to "6 Ω/ohms" (page 42).

NOTE

- Connect so that the speaker cable core wires do not protrude from the speaker terminal. The protection circuit may be activated if the core wires touch the rear panel or if the + and - sides touch each other ("Protection Circuit").
- Never touch the speaker terminals while the power supply is connected. Doing so could result in electric shock.

Protection Circuit

If the core wires touch the rear panel and the screws etc., or the ± sides touch each other, the protection circuit will be activated and the power indicator will flash red at intervals of 0.5 secs. If the protection circuit is activated, the speaker output is isolated, and the power supply goes to the standby state. If the power supply is turned off, after the power supply cord is withdrawn, please confirm that speaker cable and input cable are connected.

Also, if replaying large sound levels by using a speaker having an impedance less than that specified (eg, 4 Ω/ohms), the temperature will rise, and the protection circuit might be activated. The power supply will go into the standby state, and the power indicator will flash red at 2 second intervals.

In this case, please switch off the power supply, and wait until the AVR-4810 has cooled down, and the surrounding ventilation is good. Even if there are no problems with the surrounding ventilation and connections, in the event of the protection circuit becoming activated, due to thinking that the AVR-4810 has failed, please contact DENON Service center after switching off.

Connecting Devices

Connecting Devices

- ❑ **Connecting Devices Equipped with HDMI Terminals** (🔗 page 17)
- ❑ **Connecting the Monitor** (🔗 page 18)
- ❑ **Connecting the Playback Components**
 - Blu-ray Disc Player / DVD Player (🔗 page 18)
 - Control dock for iPod (🔗 page 19)
 - CD Player (🔗 page 19)
 - Record Player (🔗 page 19)
- ❑ **Connecting the Recording Components**
 - Digital Video Recorder (🔗 page 20)
 - Video Cassette Recorder (🔗 page 20)
- ❑ **Connect the Tuner**
 - TV (🔗 page 21)
 - Satellite Receiver / Cable Tuner (🔗 page 21)
 - FM/AM (🔗 page 22)
- ❑ **Connections to Other Devices**
 - Components Equipped with a DENON LINK connector (🔗 page 22)
 - Video Camera / Game Console (🔗 page 23)
 - USB Port (🔗 page 23)
 - Component with Multi-channel Output connectors (🔗 page 24)
 - External Power Amplifier (🔗 page 24)
 - External Controller (🔗 page 25)
- ❑ **Connecting to a Home network (LAN)** (🔗 page 25)

Connecting Devices Equipped with HDMI Terminals

Important Information

❑ About HDMI

“HDMI” is the abbreviation of “High Definition Multimedia Interface”. This interface allows transfer of digital video signals and digital audio signals over a single HDMI cable.

“HDMI”, “HDMI logo” and “High-Definition Multimedia Interface” are trademarks or registered trademarks of HDMI Licensing LLC.

❑ Functions Usable with HDMI Connections

Deep Color

Eliminates on-screen color banding, for smooth tonal transitions and subtle gradations between colors. Enables increased contrast ratio.

x.v.Color

Lets HDTVs display colors more accurately. Enables displays with natural, vivid colors. “x.v.Color” is a Sony registered trademark.

Auto Lip Sync (🔗 page 42)

If you connect the receiver to a TV that supports the Auto Lip Sync function, it can automatically correct delay between the audio and video.

HDMI Control Function (🔗 page 90)

This function allows you to operate external devices from the receiver and operate the receiver from external devices.

NOTE

- These functions will not work if the device connected to the HDMI terminal does not support Deep Color or x.v.Color signal transfer or the Auto Lip Sync function.
- The HDMI control function may not work depending on the device it is connected to and its settings.
- You cannot operate a TV or Blu-ray Disc player / DVD player that is not compatible with the HDMI control function.

❑ Copyright Protection System (HDCP)

To play DVD-Video and DVD-Audio digital video and audio via the HDMI/DVI connection, the connected Blu-ray disc player, DVD player and monitor each need to support a copyright protection system called HDCP (High-bandwidth Digital Content Protection). HDCP is copyright protection technology comprised of data encryption and authentication of the connected AV device. The AVR-4810 supports HDCP. Please consult the operating instructions of your Blu-ray disc player, DVD player or monitor.

NOTE

When a device that does not support HDCP is connected, video signals are not properly output.

Connections

The AVR-4810 allows connection of inputs from up to 6 HDMI devices and output to 2 monitors.

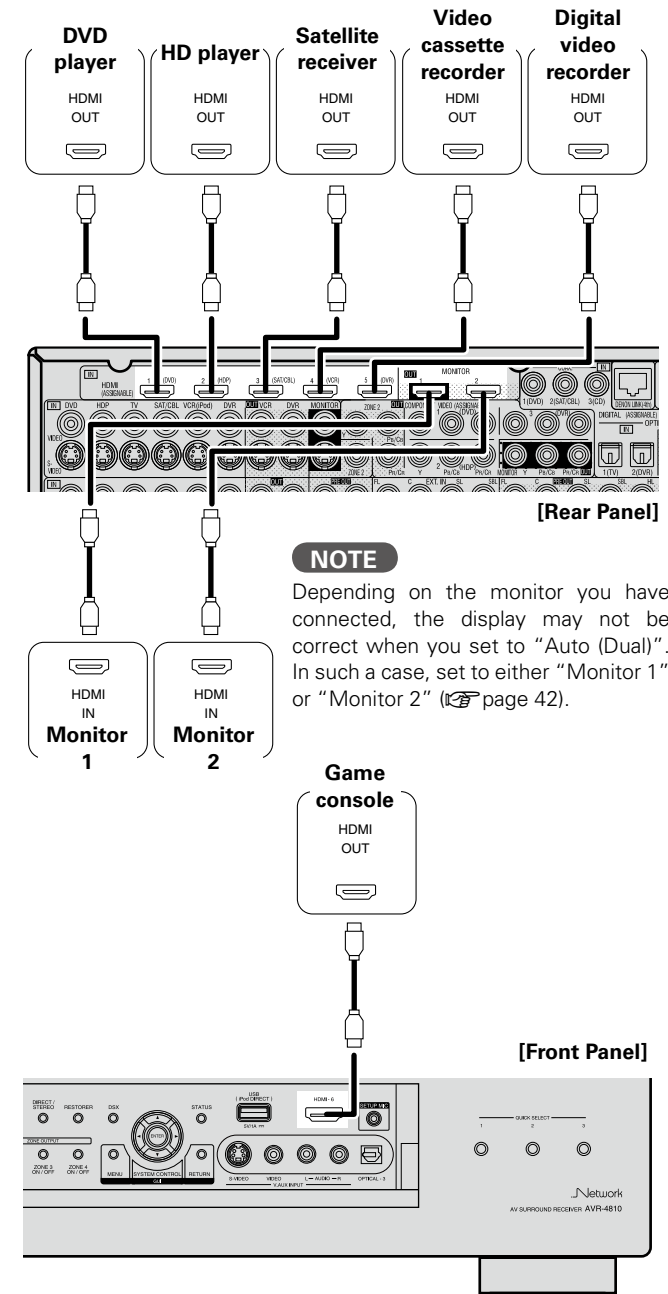

NOTE

Depending on the monitor you have connected, the display may not be correct when you set to “Auto (Dual)”. In such a case, set to either “Monitor 1” or “Monitor 2” (🔗 page 42).

Connecting Devices



- Use a cable on which the HDMI logo is indicated (a certified HDMI product) for connection to the HDMI connector. Normal playback may not be possible when using a cable other than one on which the HDMI logo is indicated (a non-HDMI-certified product).
- When the AVR-4810 is connected to other devices with HDMI cables, also connect the AVR-4810 and TV using an HDMI cable.
- When connecting a device that supports Deep Color transmission, please use a cable that is compatible with Deep Color.
- Video signals are not output if the input video signals do not match the monitor's resolution. In this case, switch the Blu-ray Disc/DVD player's resolution to a resolution with which the monitor is compatible.

NOTE

- If the GUI menu "HDMI Audio Out" setting (page 42) is set to "Amp", the sound may be interrupted when the monitor's power is turned off.
- The audio signal from the HDMI output terminal (sampling frequency, number of channels, etc.) may be limited by the HDMI audio specifications of the connected device regarding permissible inputs.

Connecting to a Device Equipped with a DVI-D Terminal

When an HDMI/DVI conversion cable (sold separately) is used, the HDMI video signals are converted to DVI signals, allowing connection to a device equipped with a DVI-D terminal.

NOTE

- No sound is output when connected to a device equipped with a DVI-D terminal. Also make the audio connections.
- Signals cannot be output to DVI-D devices that do not support HDCP.
- Depending on the combination of devices, the video signals may not be output.

Settings Related to HDMI Connections

Set as necessary. For details, see the respective reference pages.

Input Assign (page 58)

Set this to change the HDMI input terminal to which the input source is assigned.

HDMI Setup (page 42)

- Make settings for HDMI video/audio output.
- RGB Range
- Vertical Stretch
- Auto Lip Sync
- HDMI Audio Out
- Monitor Out
- HDMI Control

NOTE

The audio signals output from the HDMI connectors are only the HDMI input signals.

Connecting the Monitor

- Select the terminal to use and connect the device.
- For video connections, see "Converting Input Video Signals for Output (Video Conversion Function)" (page 10).

For instructions on HDMI connections, see "Connecting Devices Equipped with HDMI Terminals" on page 17.

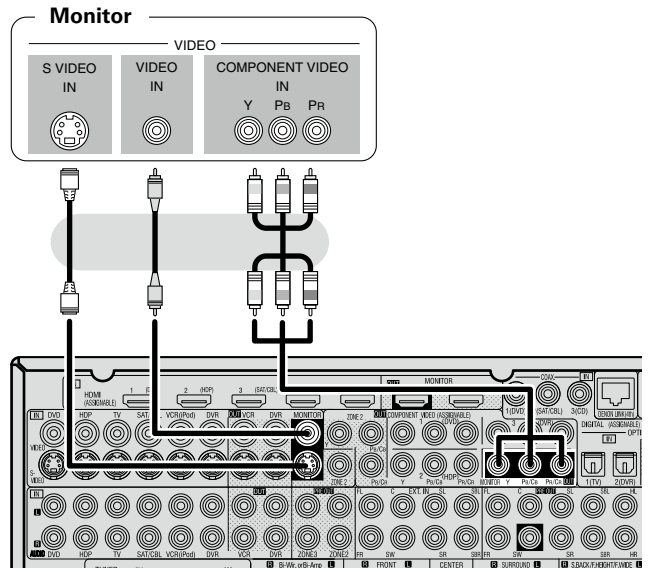

To listen to TV audio through this device, use the optical digital or analog connection.

Connecting the Playback Components

Blu-ray Disc Player / DVD Player

Select the terminal to use and connect the device.

For instructions on HDMI connections, see "Connecting Devices Equipped with HDMI Terminals" on page 17.

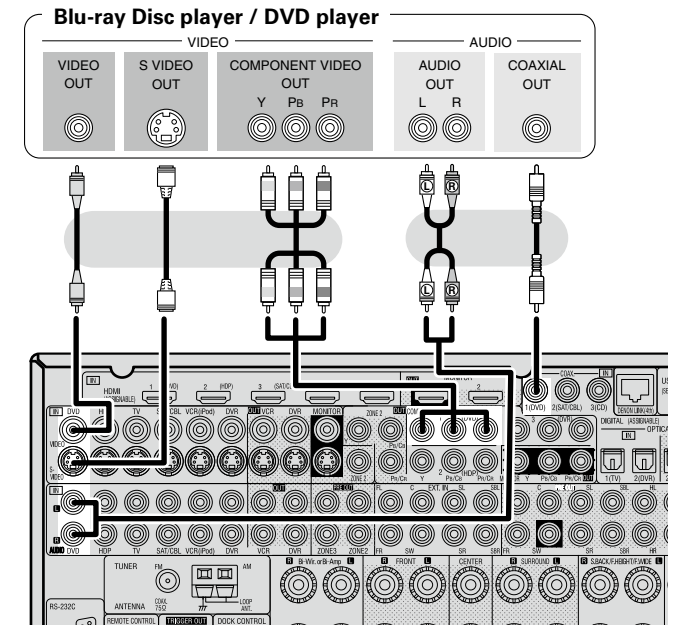

Set as Necessary

Set this to change the input signal to which the input source is assigned. "Input Assign" (page 57)

NOTE

In the case of HD audio (Dolby TrueHD, DTS-HD and Dolby Digital Plus and DTS Express) audio playback, connect with HDMI (page 17, "Connecting Devices Equipped with HDMI Terminals").

Control Dock for iPod

Use a DENON control dock for iPod (ASD-1R or ASD-11R, sold separately) to connect the iPod to the AVR-4810. For instructions on the control dock for iPod settings, refer to the control dock for iPod's operating instructions.

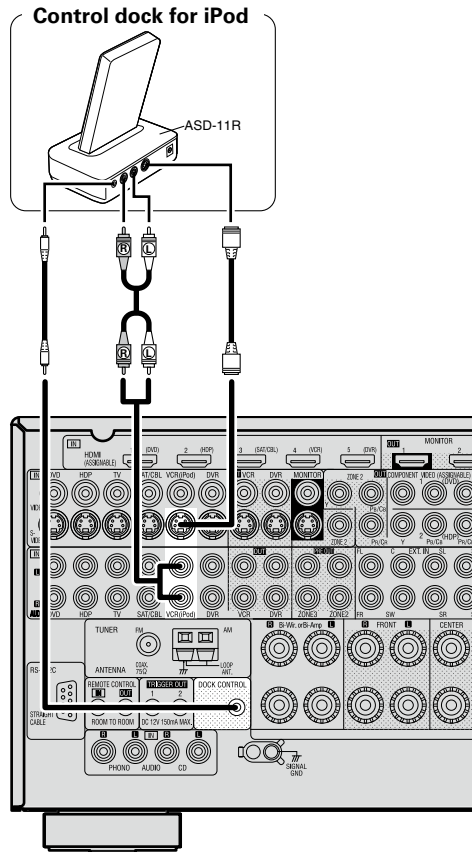

Set as Necessary

Set other than when iPod is assigned to the VCR (iPod) terminal. **"Input Assign" - "iPod dock"** (page 59)



- With the default settings, the iPod can be used connected to the VCR (iPod) connector.
- You can also connect the iPod you are using directly to the USB port of the AVR-4810 (page 23 "USB Port").

CD Player

Select the terminal to use and connect the device.

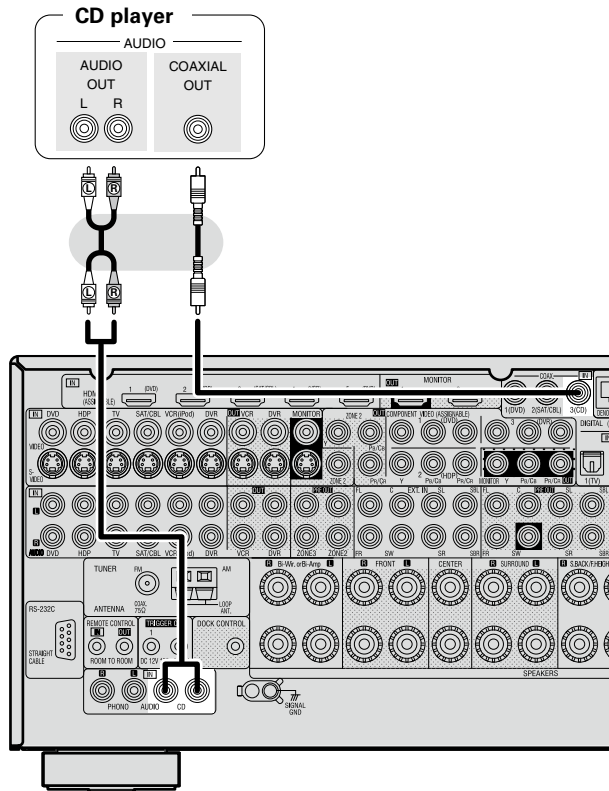

Set as Necessary

Set this to change the input signal to which the input source is assigned. **"Input Assign"** (page 57)

Record Player

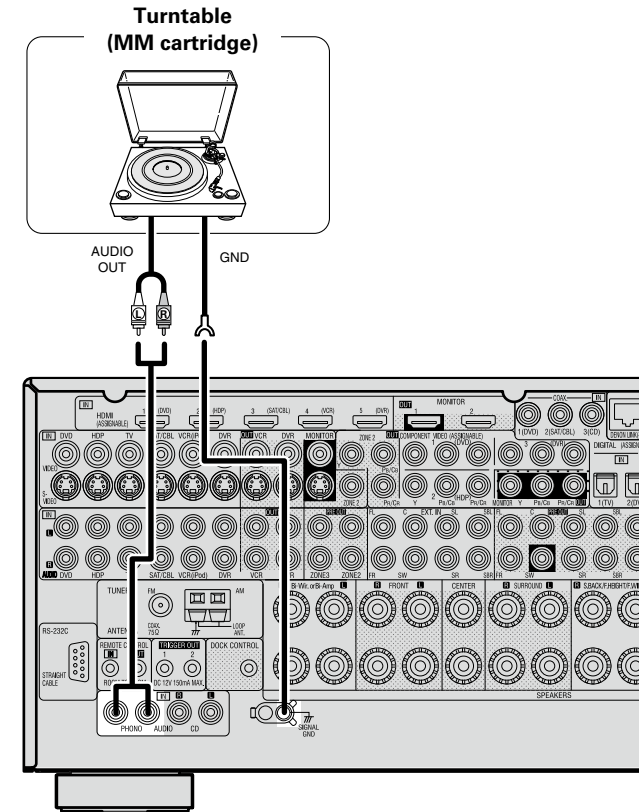

- The AVR-4810 is compatible with record players with an MM cartridge. When you connect to a record player with an MC cartridge, use a commercially available MC head amp or a step-up transformer.
- When you increase the volume without connecting the record player, there may be "booming" noise from the speakers.

NOTE

The SIGNAL GND terminal of the AVR-4810 is not a safety ground connection. Connect it to reduce noise when noise is excessive. Note that depending on the record player, connecting the ground line may have the reverse effect of increasing noise. In this case, it is not necessary to connect the ground line.

Connecting Devices

Connecting the Recording Components

Digital Video Recorder

- Select the terminal to use and connect the device.
- When recording analog audio, use the analog connection.
- See page 89 "Recording on an External Device (REC OUT mode)" for operating instructions.

For instructions on HDMI connections, see "Connecting Devices Equipped with HDMI Terminals" on page 17.

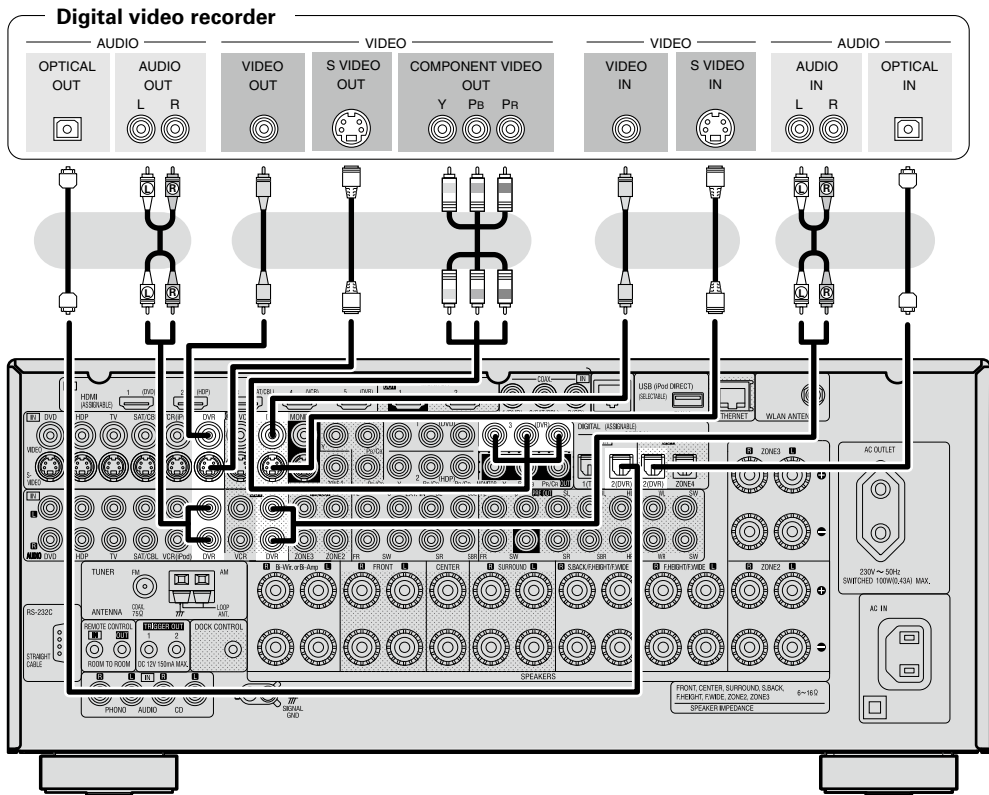

Video Cassette Recorder

- Select the terminal to use and connect the device.
- When recording analog audio, use the analog connection.
- See page 89 "Recording on an External Device (REC OUT mode)" for operating instructions.

For instructions on HDMI connections, see "Connecting Devices Equipped with HDMI Terminals" on page 17.

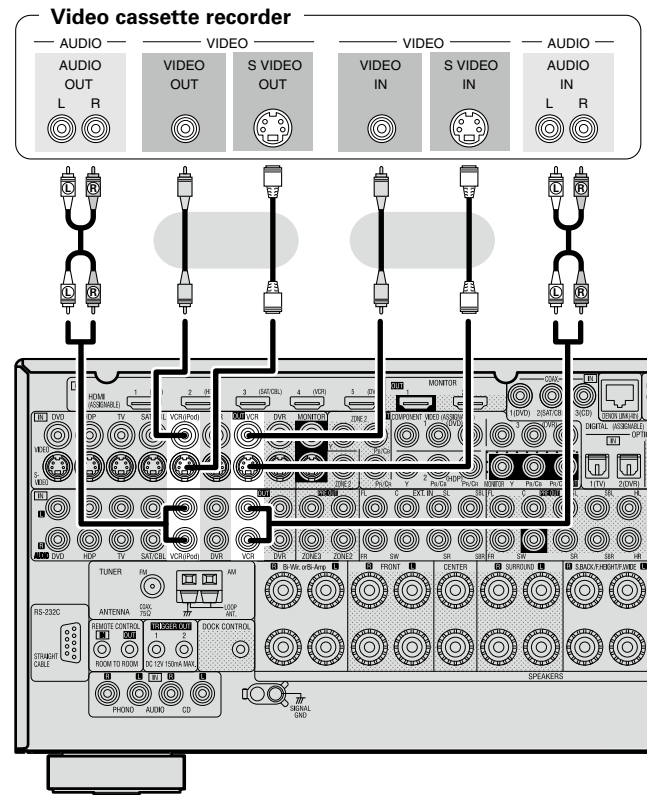

Set as Necessary

Set this to change the input signal to which the input source is assigned.
"Input Assign" (page 57)

NOTE

To record video signals through the AVR-4810, use the same type of video cable for connection between the AVR-4810 and the player as the cable used for connection between the AVR-4810 and the recorder.

Set as Necessary

Set this to change the input signal to which the input source is assigned.
"Input Assign" (page 57)

NOTE

To record video signals through the AVR-4810, use the same type of video cable for connection between the AVR-4810 and the player as the cable used for connection between the AVR-4810 and the recorder.

Connect the Tuner

TV

Select the terminal to use and connect the device.

For instructions on HDMI connections, see “Connecting Devices Equipped with HDMI Terminals” on page 17.

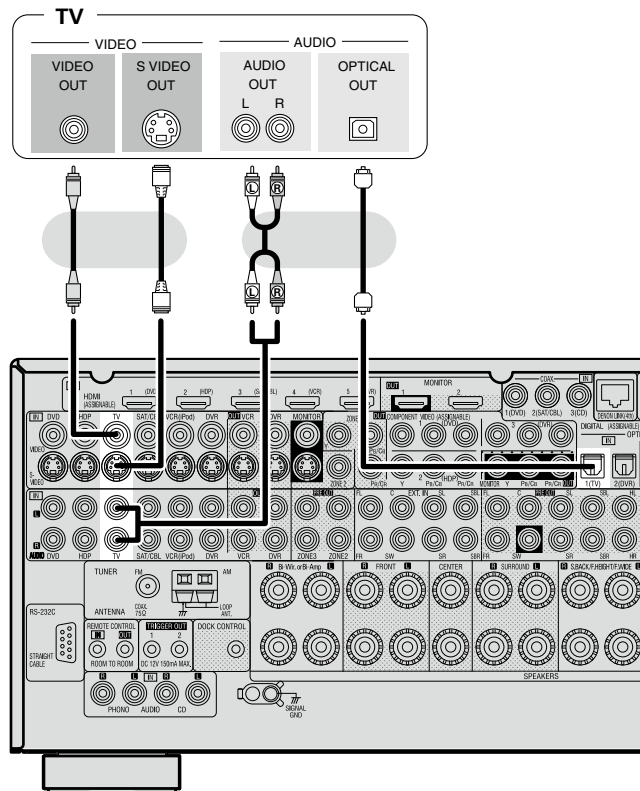

Set as Necessary

Set this to change the input signal to which the input source is assigned.
“Input Assign” (👉 page 57)

Satellite Receiver / Cable Tuner (Set Top Box)

Select the terminal to use and connect the device.

For instructions on HDMI connections, see “Connecting Devices Equipped with HDMI Terminals” on page 17.

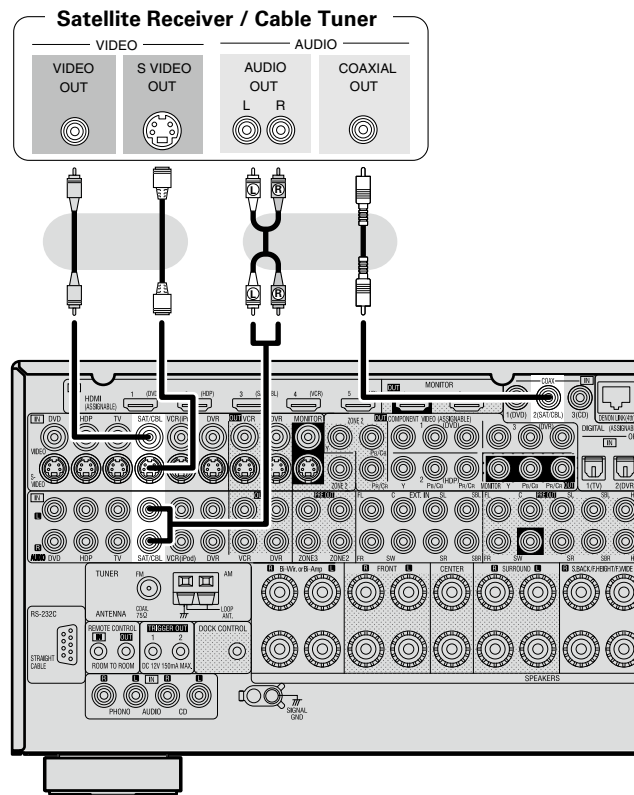

Set as Necessary

Set this to change the input signal to which the input source is assigned.
“Input Assign” (👉 page 57)

Connecting Devices

FM/AM

An FM antenna cable plug can be connected directly.

Direction of broadcasting station

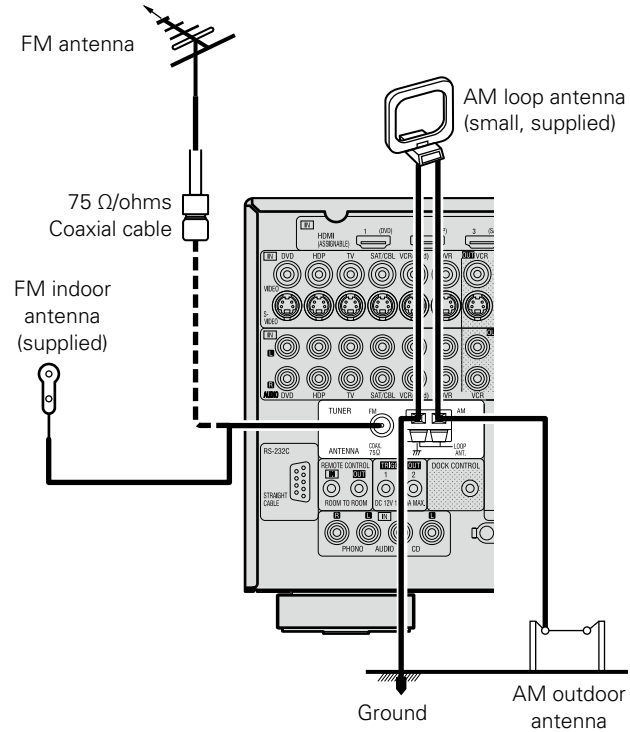

AM loop antenna assembly

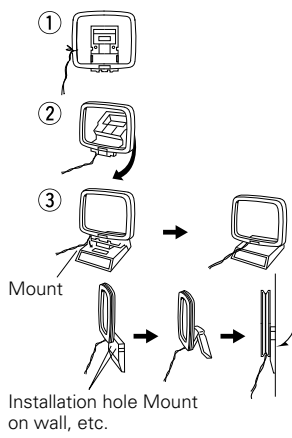

Remove the vinyl tie and take out the connection line.

Bend in the reverse direction.

a. With the antenna on top of any stable surface.

b. With the antenna attached to a wall.

Connection of AM antennas

1. Push the lever.
2. Insert the conductor.
3. Return the lever.

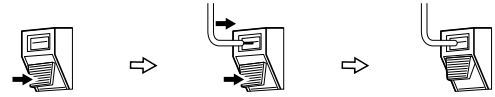

NOTE

- Do not connect two FM antennas simultaneously.
- Even if an external AM antenna is used, do not disconnect the AM loop antenna.
- Make sure the AM loop antenna lead terminals do not touch metal parts of the panel.

Connections to Other Devices

Components Equipped with a DENON LINK Connector

Multichannel playback is possible, including DVD-Audio and Super Audio CD (refer page 89 "Playing Super Audio CD"). In addition, refer to page 88 "Playing a Blu-ray Disc Player Compatible with DENON LINK 4th" for information on connecting a player that supports DENON LINK 4th edition.

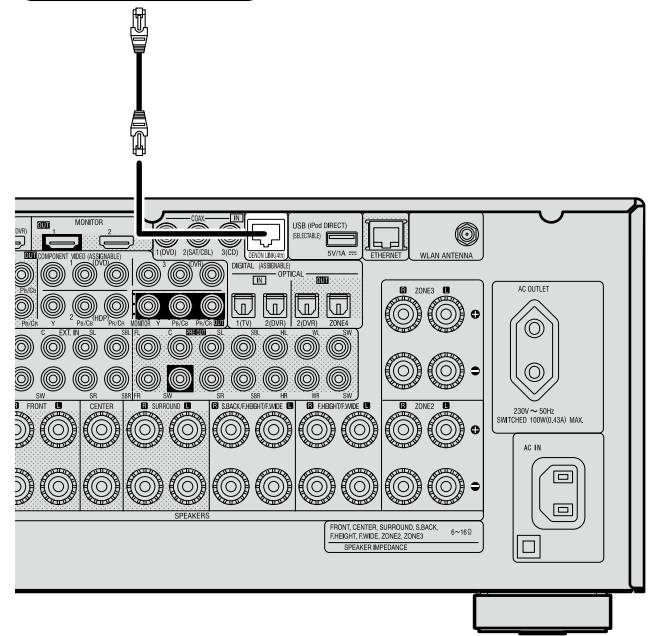
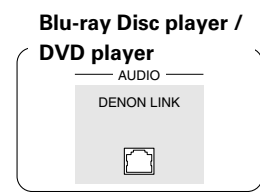

Set as Necessary

When connecting by use of DENON LINK, set "Digital" to "D.LINK".
"Input Assign" (refer page 58)

Video Camera / Game Console

Select the terminal to use and connect the device.

For instructions on HDMI connections, see "Connecting Devices Equipped with HDMI Terminals" on page 17.

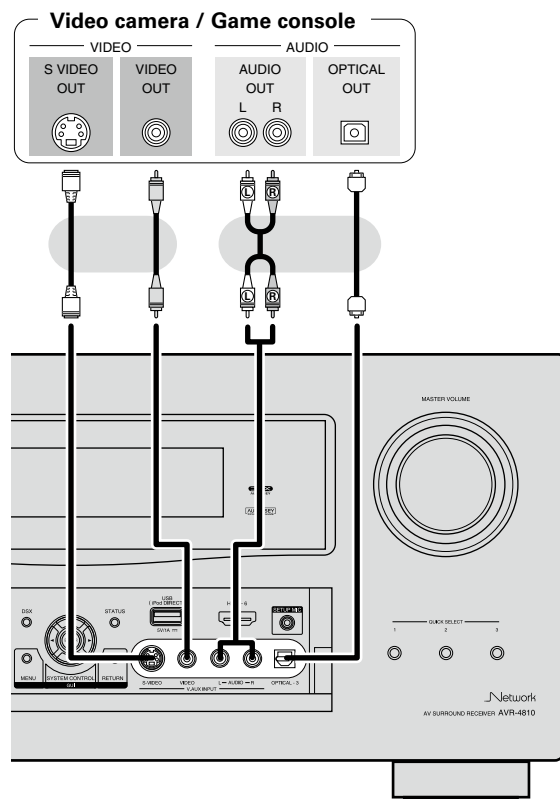

Set as Necessary

Set this to change the input signal to which the input source is assigned.
"Input Assign" (🔧 page 57)

NOTE

When a non-standard video signal from a game machine or some other source is input, the video conversion function might not operate.

USB Port

When you connect an iPod or USB memory device to the USB port, you can enjoy music, etc., stored on the iPod or USB memory device.

❑ Front panel

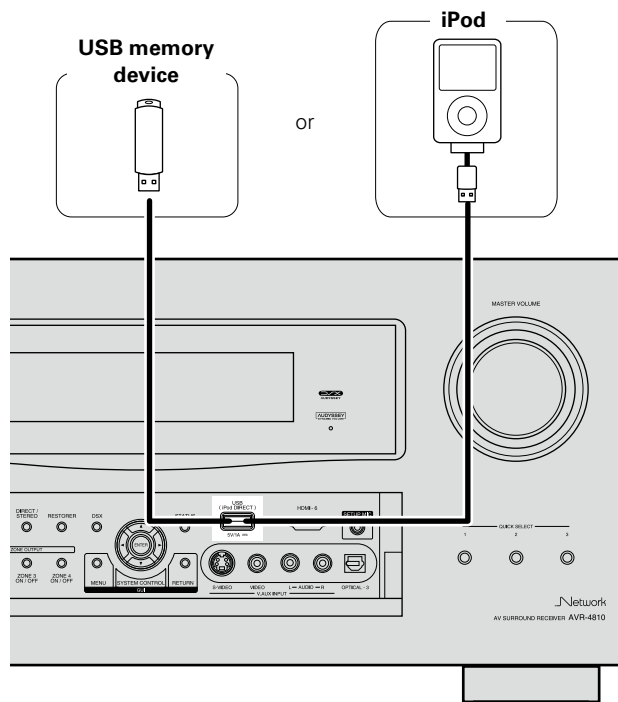

Set as Necessary

Set when you change the USB port for use.
"USB Select" (🔧 page 62)



- In the initial status, USB memory devices can be used by connecting them to the USB port on the front panel.
- To connect an iPod to the AVR-4810, use the USB cable supplied with the iPod.
- When you want to playback a movie file stored on the iPod, use the DENON control dock for iPod (ASD-11R or ASD-1R, sold separately) (🔧 page 19 "Control Dock for iPod").
- For iPods, playback is possible on iPod touch, classic and nano sold from generation 5 on. For details, check the DENON web site or page 64.

❑ Rear panel

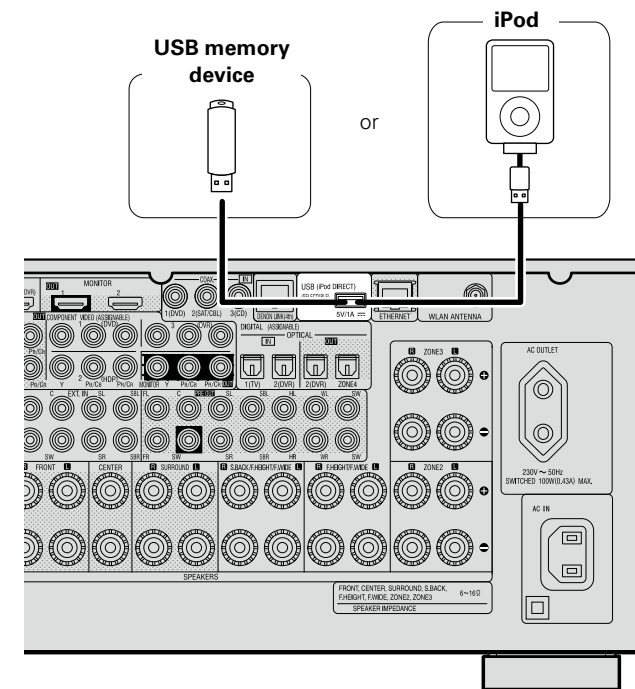

NOTE

- **You cannot use the USB port on the front panel and rear panel simultaneously.** Select and connect the USB port you are to use.
- Do not use an extension cable when connecting a USB memory device. This may cause radio interference with other devices.

Connecting Devices

Component with Multi-channel Output connectors

The video signal can be connected in the same way as a Blu-ray Disc player / DVD player (page 18 "Blu-ray Disc Player / DVD Player").

Blu-ray Disc player / DVD player / External decoder

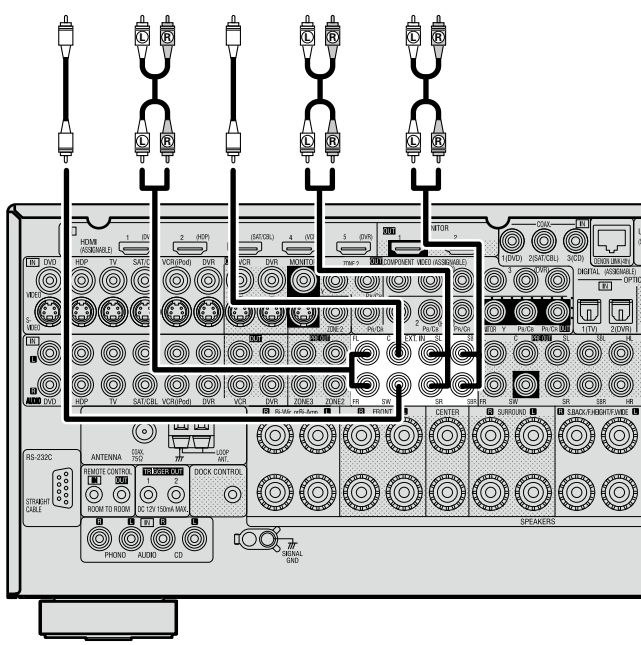
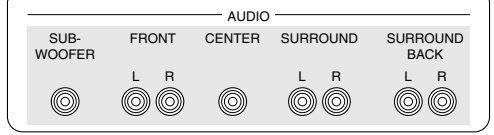

Set as Necessary

To play analog signals input from the external input (EXT. IN) terminal, set "Input Mode" (page 61) to "EXT. IN".

When a device is connected to the SBL/SBR terminal of the external input terminals (EXT. IN), set "Amp Assign" - "Extra Channel" (page 40) to "SB".

External Power Amplifier

- Select the terminal to use and connect the device.
- Connect when using an external power amp or an amp you already have.

Power amplifier

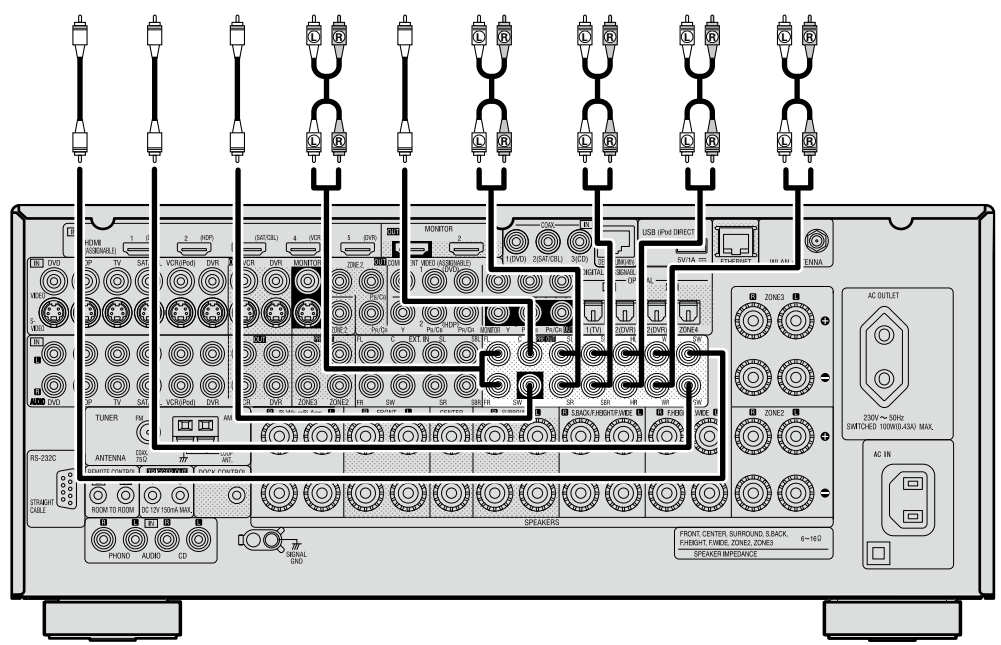
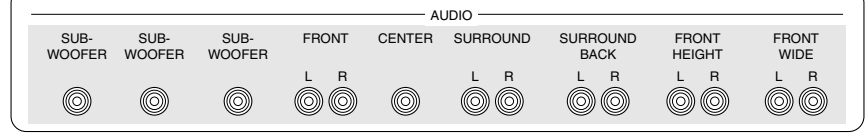

NOTE

When speakers have been connected to PRE OUT terminals, do not connect the speakers to the speaker terminals.

- When using just one surround back speaker, connect it to the left channel (L).
- Use the volume control on the subwoofer to control subwoofer volume.
- If the subwoofer volume sounds low, use the volume control provided on the subwoofer to adjust the volume.

External Controller

RS-232C connector

When you connect an external control device, you can control the AVR-4810 with the external control device. Perform the operation below beforehand.

- 1 Turn on the AVR-4810's power.
- 2 Turn off the AVR-4810's power from the external controller.
- 3 Check that the AVR-4810 is in the standby mode.

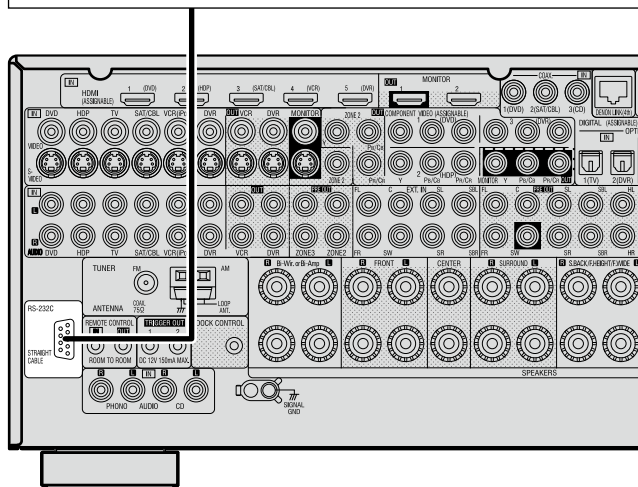

Set as Necessary

Set this to use the RS-232C connector for the DENON RF remote controller.
"232C Port" (☞ page 55)



When using the AVR-4810 in combination with the DENON RF remote controller (RC-7000CI, sold separately) or RF remote receiver (RC-7001RCI, sold separately), two-way communication is enabled. The AVR-4810's status information as well as iPod and Internet audio music files can be browsed watching the RF Remote Controller's display. For details, refer to the operating instructions of the respective devices.

NOTE

On the GUI menu, when setting "232C Port" to "2Way Remote", you cannot use the RS-232C connector as an external controller (☞ page 55).

REMOTE CONTROL jacks

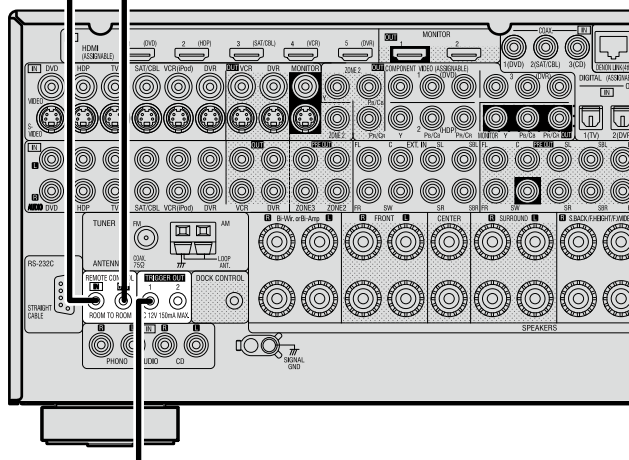
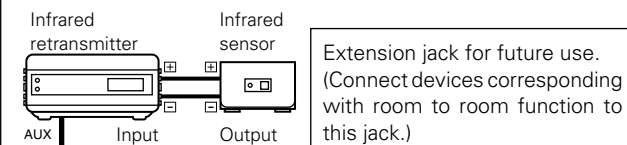

TRIGGER OUT jacks

The TRIGGER OUT output terminal outputs a maximum 12 V/150 mA electrical signal. When a device with TRIGGER IN terminal is connected via a monaural mini-plug, the connected device's power on/standby can be controlled through linked operation to the AVR-4810.

Set as Necessary

Set to change the conditions for linked operation via the TRIGGER OUT 1 or TRIGGER OUT 2 terminal.
"Trigger Out1" or **"Trigger Out2"** (☞ page 54)



When connecting a 2nd device, connect to the TRIGGER OUT 2 terminal in the same way as the TRIGGER OUT 1 terminal.

Connecting to a Home Network (LAN)

When you connect the AVR-4810 to a home network, you can enjoy listening to music files stored on your PC, internet radio audio and other sources. You can also control the AVR-4810 from your PC via the Web browser.

[Wired LAN]

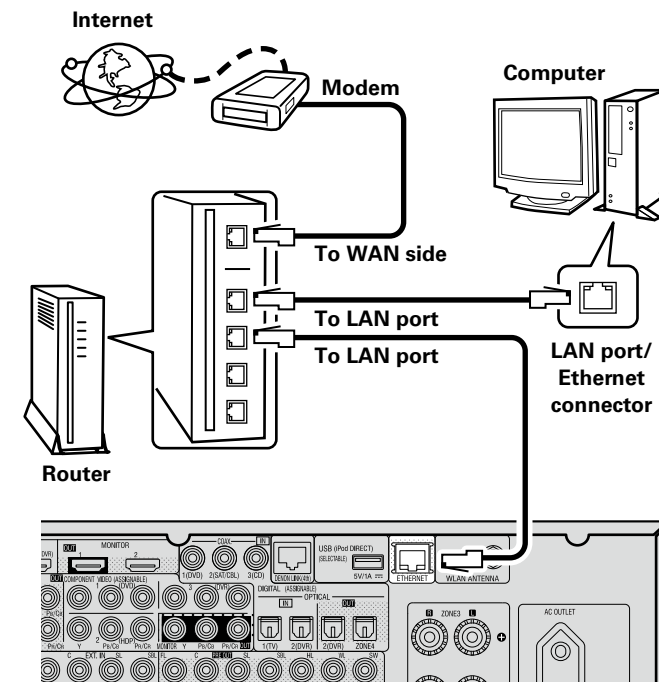

For connections to the Internet, contact an ISP (Internet Service Provider) or a computer shop.

See overleaf

Connecting Devices

[Wireless LAN]

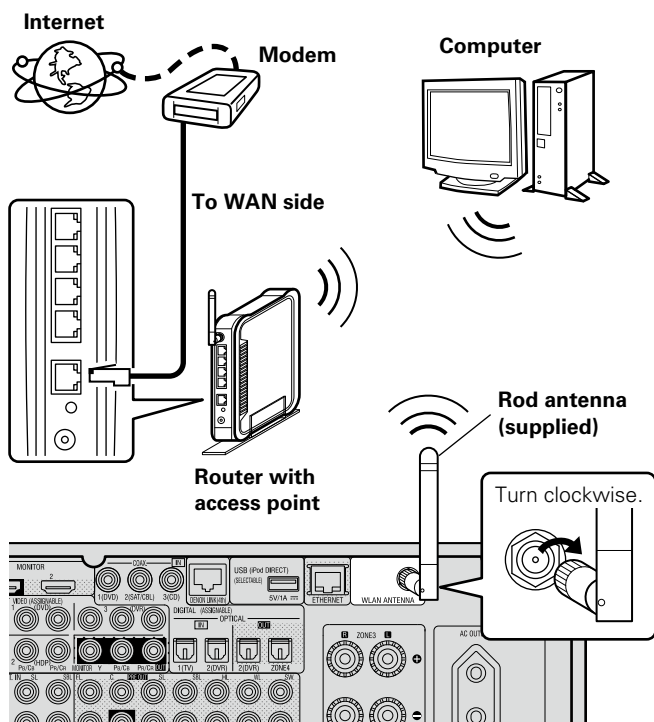

Required system

❑ Broadband Internet connection

❑ Modem

❑ Router

- When using the AVR-4810, we recommend you use a router equipped with the following functions:
 - Built-in DHCP server
This function automatically assigns IP addresses on the LAN.
 - Built-in 100BASE-TX switch
When connecting multiple devices, we recommend a switching hub with a speed of 100 Mbps or greater.
- When using with a wireless LAN, prepare a broadband router with built-in access point.

❑ Ethernet cable (CAT-5 or greater recommended)

Use for wired LAN.

Some flat type Ethernet cables are easily affected by noise. We recommend using a normal type cable.

❑ Computer
[Recommended system]

- **OS :**
Windows® XP Service Pack2 or later, Windows Vista
 - **Software (Prepare one of the following.)**
 - Windows Media Player ver.11
 - DLNA-compatible server software
 - **Internet browser :**
Microsoft Internet Explorer 6 or later
 - **LAN port**
 - **300 MB or more free disk space**
- ※ Operation is possible with DLNA servers other than the above, but such DLNA servers are not supported. For details, check the Web.

NOTE

- A contract with an ISP is required to connect to the Internet. No additional contract is needed if you already have a broadband connection to the Internet.
- The types of routers that can be used depend on the ISP. Contact an ISP or a computer shop for details.
- Depending on the server, video files may be displayed, but they cannot be played on the AVR-4810.



- If you have an Internet provider contract for a line on which network settings are made manually, make the settings at “Network Connecting” (page 45).
- With the AVR-4810, it is possible to use the DHCP and Auto IP functions to make the network settings automatically.
- When using the AVR-4810 with the broadband router’s DHCP function enabled, the AVR-4810 automatically performs the IP address setting and other settings. When using the AVR-4810 connected to a network with no DHCP function, make the settings for the IP address, etc., at “Network Connecting” (page 45).
- The AVR-4810 is not compatible with PPPoE. A PPPoE-compatible router is required if you have a contract for a line of the type with which the PPPoE is set.
- Depending on the ISP with which you have your contract, it may be necessary to make proxy server settings to use the Internet radio function. If you made proxy server settings on the computer to connect to the Internet, make the proxy server settings on the AVR-4810 in the same way.

Connecting the Power Cord

Wait until all connections have been completed before connecting the power cord.

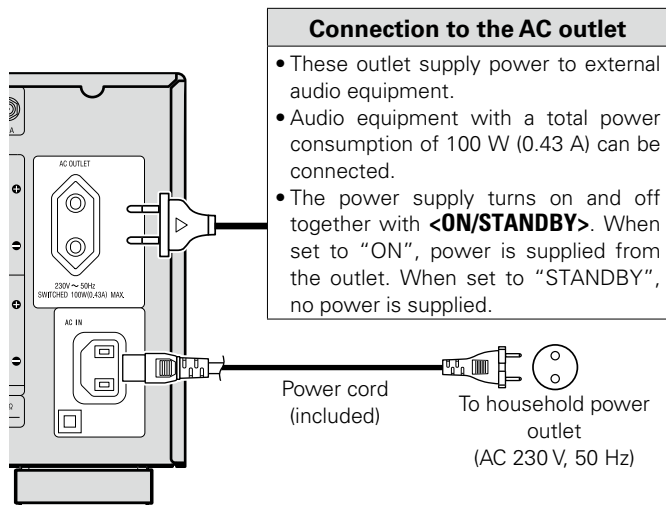

NOTE

- Insert the AC plugs securely. Incomplete connections could cause noise.
- Only use the AC outlet to plug in audio equipment. Do not use them as power supplies for hairdryers or anything other than audio equipment.

Symbols used to indicate buttons in this manual

- Button located on both the main unit and the remote control unit → **BUTTON**
- Button only on the main unit → **<BUTTON>**
- Button only on the remote control unit → **[BUTTON]**

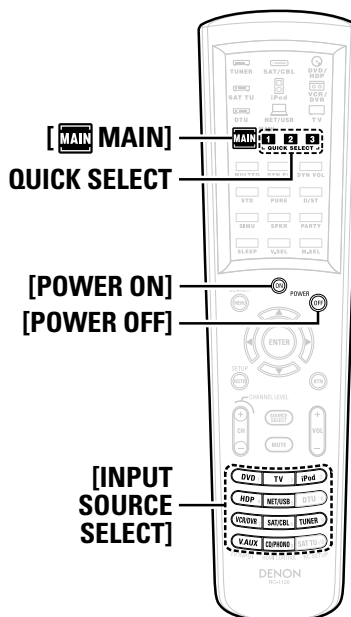
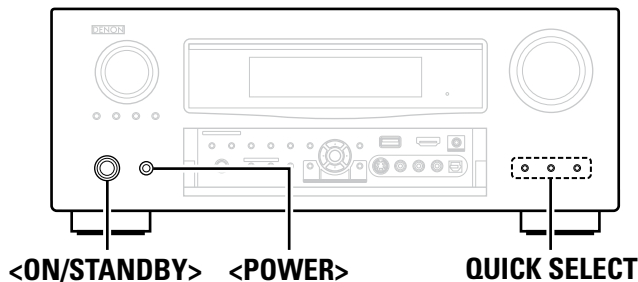

Once Connections are Completed

Turning the Power On

- 1 Press <POWER>**.
The power indicator lights red and the power is set to the standby mode.
- 2 Press [MAIN] to switch the main remote control unit to "MAIN" mode** (☞ page 99 "Operating the Main Remote Control Unit").
- 3 Press <ON/STANDBY> or [POWER ON]**.
The power indicator flashes green and the power turns on.

※ Also press [INPUT SOURCE SELECT] or **QUICK SELECT** when in standby mode, the power turns on. When [INPUT SOURCE SELECT] has been pressed, the input source set with the [INPUT SOURCE SELECT] is set. If a **QUICK SELECT** has been pressed, the input source stored in the memory for the quick select function is set (☞ page 91 "Saving Frequently Used Settings (Quick Select Function)").

Turning the Power Off

- 1 Press [MAIN] to switch the main remote control unit to "MAIN" mode** (☞ page 99 "Operating the Main Remote Control Unit").
- 2 Press <ON/STANDBY> or [POWER OFF]**.
The power is set to the standby mode.
- 3 Press <POWER>**.
The power indicator turns off, and so does the power.

NOTE

Power continues to be supplied to some of the circuitry even when the power is in the standby mode. When leaving home for long periods of time or when traveling, either press **<POWER>** to turn off the power, or unplug the power cord from the power outlet.

Settings

Getting Started
Connections
Settings
Playback
Multi-zone
Remote Control
Information
Troubleshooting
Specifications

Symbols used to indicate buttons in this manual

- Button located on both the main unit and the remote control unit → **BUTTON**
- Button only on the main unit → **<BUTTON>**
- Button only on the remote control unit → **[BUTTON]**

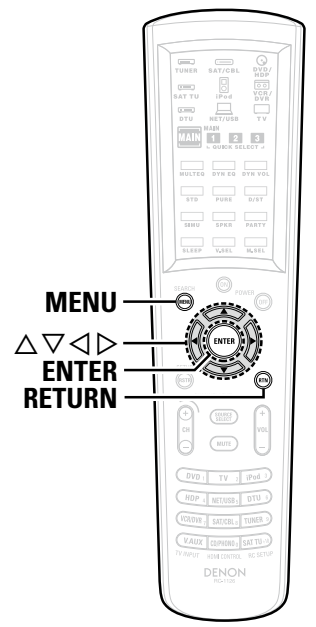
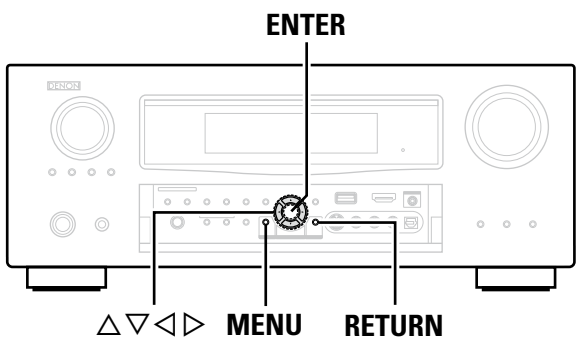

GUI Menu Map

Pressing **MENU** displays the GUI menu. From this menu, you can move to various setting screens.

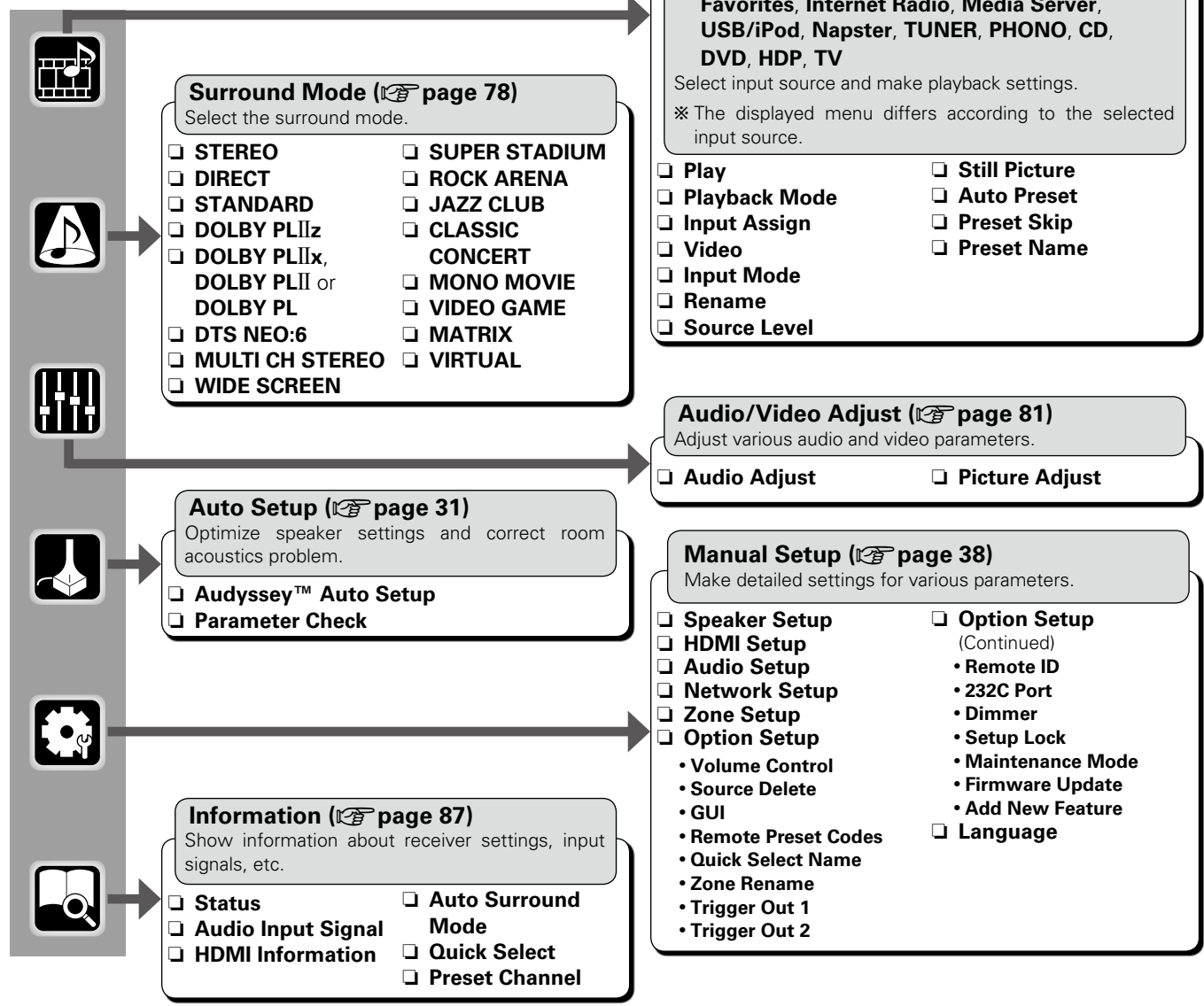

GUI Menu Operation



- When a TV is connected to the AVR-4810, the GUI menu, sound field parameters, etc., can be displayed on the TV.
- This allows you to operate the AVR-4810 and make settings on it while looking at the GUI menu displayed on the TV.
- Operate with the main remote control unit switched to the "MAIN" mode (page 99 "Operating the Main Remote Control Unit").

1 Press MENU.

The GUI menu is displayed on the TV screen.

2 Press Δ ∇ \triangleright to select the menu to be set or operated.

※ To return to the previous item, press \triangleleft or RETURN.

3 Press ENTER to enter the setting.

❑ Exiting the GUI Menu

Press **MENU** while the GUI menu is displayed. The GUI menu display disappears.

Example of the Display of the GUI Mark at a Title

Items for which this mark is indicated at the title can be operated from the GUI. We recommend performing such operations from the GUI.



Making Detailed Settings (Manual Setup)

This is the GUI icon for this setting item or for the menu series to which this item belongs.

Examples of GUI Menu Screen Displays

Typical examples are described below.

[Example 1] Menu selection screen (Top menu)

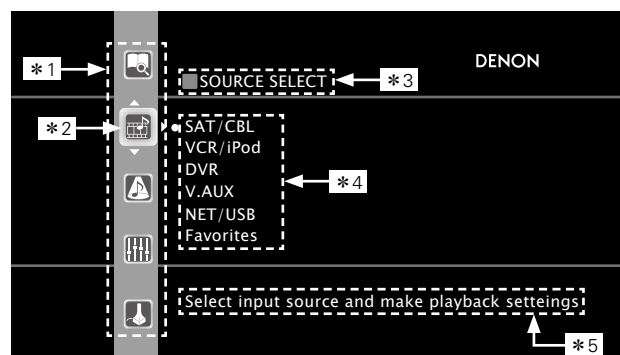

- * 1 : List GUI menu setup icons
- * 2 : Currently selected setup icon
- * 3 : Currently selected setup item
- * 4 : List of currently selected setup items
- * 5 : Guide text for the currently selected setup item

Press ∇ to select "A" and then press \triangleright . (Or press ENTER.)

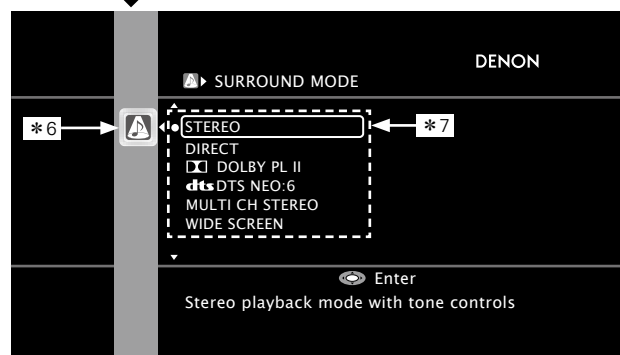

- * 6 : Selected setup icon
- * 7 : Options of the selected setup item

[Example 2] Audyssey Auto Setup screen (with illustration)

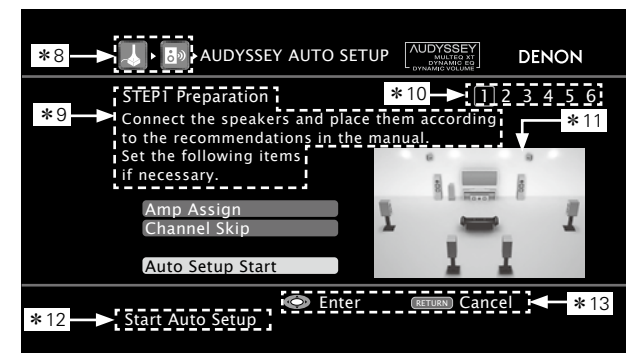

- * 8 : History icon
- * 9 : Operation guidance text
- * 10 : Operation step indicators
- * 11 : Illustration
- * 12 : Guide text for the currently selected setup item
- * 13 : Operation button guidance

❑ Icon

Switch the selected item (Use Δ to switch.)



Switch to the next item (Use \triangleright or ENTER to switch.)

Selected item

Switch the selected item (Use ∇ to switch.)

❑ List

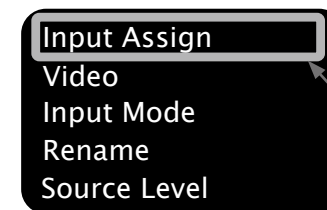

Switch to the next item (Use \triangleright or ENTER to switch.)

Selected item

※ Switch the selected item using Δ ∇ .

GUI Menu Operation

Symbols used to indicate buttons in this manual

Button located on both the main unit and the remote control unit → **BUTTON**
 Button only on the main unit → **<BUTTON>**
 Button only on the remote control unit → **[BUTTON]**

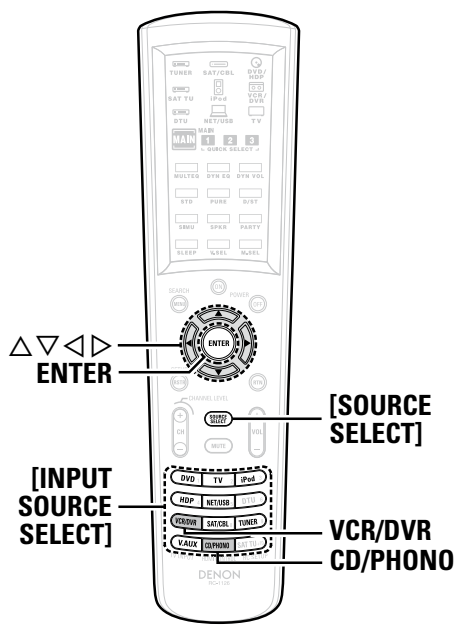
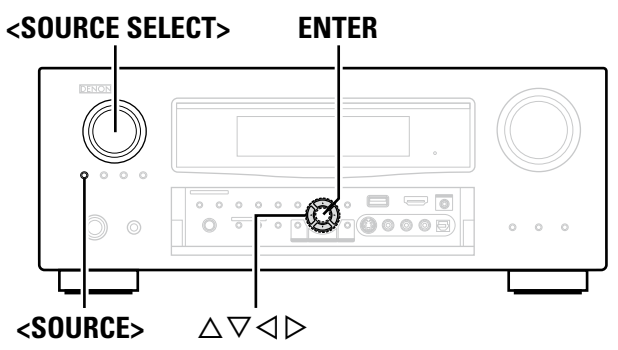

Selecting the Input Source

There are three ways to select the input source, as described below.

- 1 Selecting the input source using the "Source Select" menu (GUI menu)
- 2 Selecting the input source using the **[INPUT SOURCE SELECT]** (Main remote control unit)
- 3 Selecting the input source using the **<SOURCE SELECT>** (Main unit)

1 Using the "Source Select" Menu

Switch the main remote control unit to the "MAIN" or "MACRO" mode when performing this operation (☞ page 99 "Operating the Main Remote Control Unit").
 If the main remote control unit is in "ZONE2", "ZONE3" or "ZONE4" mode, the "Source Select" menu will not be displayed when **[SOURCE SELECT]** is pressed.

1 Press **[SOURCE SELECT]**. Display the "Source Select" menu.

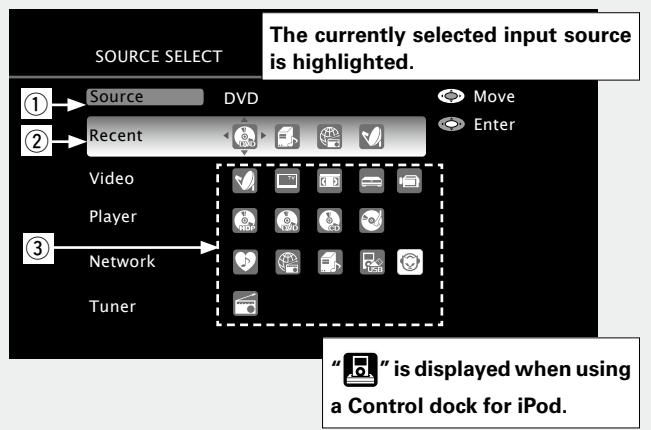

- 1 **Input Source** : The name of the highlighted input source is displayed.
- 2 **Recently used sources** : The recently used input sources (up to 5) are displayed.

3 Icons for the input sources in the different categories are displayed.

- Video : (SAT/CBL), (TV), (VCR), (DVR), (V.AUX)
- Player : (HDP), (DVD), (CD), (PHONO)
- Network : (Favorites), (Internet Radio), (Media Server), (USB/iPod), (Napster)
- Tuner : (TUNER)

2 Use $\Delta \nabla \triangleleft \triangleright$ to select the input source icon, then press ENTER.
 The input source is set and the source selection menu is turned off.

- Use the device selection buttons on the main remote control unit to set the device to be operated beforehand.
- When using with an iPod connected directly to the AVR-4810's USB port, select "USB/iPod" for the input source.
- Input sources that are not going to be used can be set ahead of time. Make this setting at "Source Delete" (☞ page 52).
- To turn off the source selection menu without selecting an input source, press **[SOURCE SELECT]** again.

2 Operating on the Main Remote Control Unit

Press **[INPUT SOURCE SELECT]**.
 The desired input source can be selected directly.

※ To operate the AVR-4810 using the main remote control unit, set the remote control unit to the "MAIN" mode (☞ page 99 "Operating the Connected Devices by Remote Control Unit").
 ※ Pressing the **VCR/DVR** button and the **CD/PHONO** button on the main remote control unit will switch between the following.



3 Operating on the Main Unit

Turn **<SOURCE SELECT>**.
 ※ If "ZONE2/3/4 Rec Select", "Video Select" or "Tuning Preset" mode is selected for the input source, press **<SOURCE>** before turning the **<SOURCE SELECT>**.



Make the Optimal Speaker Settings, and Correct the Room Acoustics (Audyssey™ Auto Setup)

The acoustic characteristics of the connected speakers and listening room are measured and the optimum settings are made automatically.

Audyssey Auto Setup Flow

1 Connect the Included Setup Microphone
(☞ page 32)



2 Audyssey Auto Setup Preparations
(☞ page 33)

- ❑ **Change the Amplifier Assignment (Amp Assign)**
(☞ page 33)
- ❑ **Set the Channels You will not Use (Channel Skip)**
(☞ page 33)



3 Perform Audyssey Auto Setup (☞ page 34)



Check the Measuring Results and Equalizer Type after Audyssey Auto Setup (Parameter Check) (☞ page 37)

Important information

Audyssey MultEQ® XT automatically measures the acoustical problems in the listening environment to create the best audio experience for your home theater.

- When performing Audyssey Auto Setup, the MultEQ® XT / Dynamic EQ™ / Dynamic Volume™ functions become valid (☞ page 83, 84).
- Use the included setup microphone (DM-A409) to perform Audyssey Auto Setup.
- Measurements are performed by placing the setup microphone successively at multiple positions throughout the entire listening area, as shown in **[Example ①]**. For best results, we recommend you measure in 6 or more positions, as shown in the illustration. Even if the listening environment is small as shown in **[Example ②]**, measuring at multiple points throughout the listening environment results in more effective correction.

❑ When Using the Surround Back Speakers

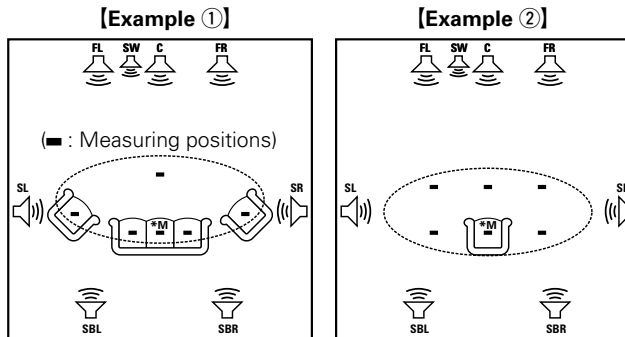

❑ When Using the Front Height Speakers

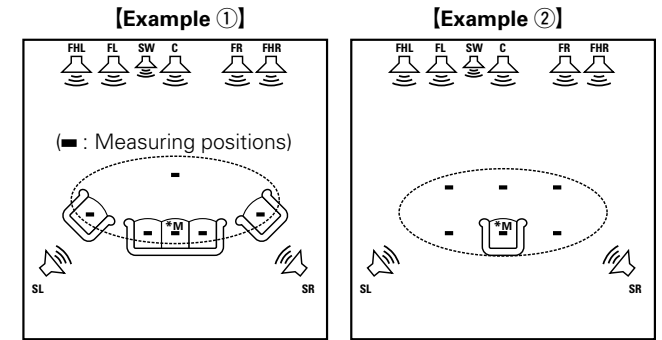

❑ When Using the Front Wide Speakers

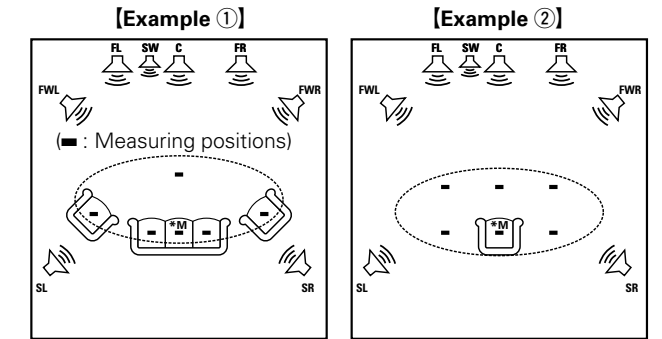

- FL : Front speaker (L)
- FR : Front speaker (R)
- FHL : Front height speaker (L)
- FHR : Front height speaker (R)
- FWL : Front wide speaker (L)
- FWR : Front wide speaker (R)
- C : Center speaker
- SW : Subwoofer
- SL : Surround speaker (L)
- SR : Surround speaker (R)
- SBL : Surround back speaker (L)
- SBR : Surround back speaker (R)

About the main listening position (*M)

The main listening position refers to the position where listeners would normally sit or where one would normally sit alone within the listening environment. Audyssey MultEQ XT uses the measurements from this position to calculate speaker distance, level, polarity, and the optimum crossover value for the subwoofer.

See overleaf

Make the Optimal Speaker Settings, and Correct the Room Acoustics (Audyssey™ Auto Setup)

NOTE

- Loud test sounds may be played during Audyssey Auto setup. This is part of normal operation. If there is background noise in room, these test signals will increase in volume.
- Do not stand between the speakers and setup microphone or allow obstacles in the path while the measurements are being made. This will cause inaccurate readings.
- Make the room as quiet as possible. Background noise can disrupt the room measurements. Close windows, silence cell phones, televisions, radios, air conditioners, fluorescent lights, home appliances, light dimmers, or other devices as measurements may be affected by these sounds. Cell phones should be placed away from all audio electronics during the measurement process as Radio Frequency Interference (RFI) may cause measurement disruptions (even if the cell phone is not in use).
- Operating **MASTER VOLUME** during the measurements will cancel the measurements.

1 Connect the Included Setup Microphone

- Do not remove the setup microphone until Audyssey Auto Setup is completed.
- When using headphones, unplug the headphones before starting Audyssey Auto Setup.

1 Check the speaker connections.
(🔗 page 14 "Speaker Connections")

2 Turn on the TV and subwoofer power.
Change the TV input to AVR-4810 input.

3 Turn on the AVR-4810 power.
(🔗 page 27 "Turning the Power On")

4 Connect the setup microphone to the SETUP MIC jack of the AVR-4810.

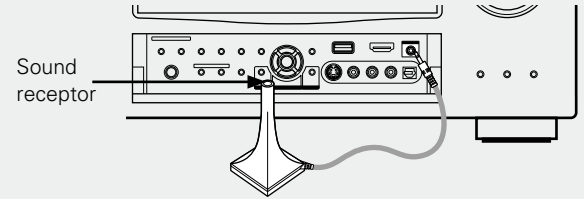

"Audyssey Auto Setup" screen is displayed when you connect the setup microphone.

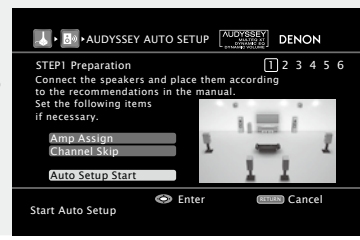

5 Mount the setup microphone on a tripod or stand and place it in the main listening position.

When placing the setup microphone, adjust the height of the sound receiver part to the level of the listener's ear.

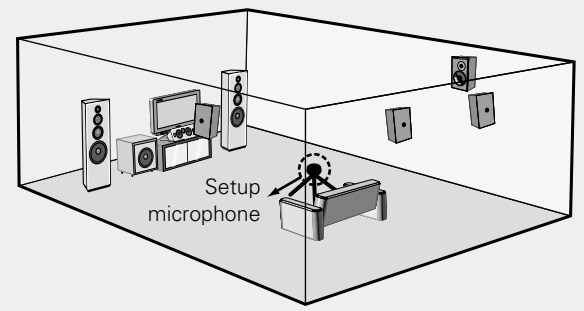

If your subwoofer provides volume and crossover settings, set these as shown below before starting Audyssey Auto Setup.

- Volume setting : "12 o'clock" position" or the middle of the gain knob's range.
- Low path filter setting is "Off", or Crossover Frequency setting is "Maximum/Highest Frequency"
- Phase setting : 0°
- Standby mode setting : "Off"
- If you connect two or three subwoofers, the best results will be achieved when:
 - Subwoofers are placed at equal distances from the main listening position.
 - Individual level controls on the back of each subwoofer are set so that each subwoofer plays at the same level.

NOTE

- Do not hold the microphone in your hand during measurements.
- Avoid placing the microphone close to a seat back or wall as sound reflections may give inaccurate results.
- When you use two or three subwoofers, please adjust the subwoofer volume controls individually so that each subwoofer level is as close as possible to 75 dB using the test tone (🔗 page 41) before Audyssey Auto Setup. If the subwoofer level error message appears, please select "Skip" and then press **ENTER**.

2 Audyssey Auto Setup Preparations

around items indicate the settings.

STEP1 Preparation

Perform the following settings if adjustments, etc., are required for the speaker environment you're using.

If you do not need to perform the following settings, or have already completed them, select "Auto Setup Start" and then press **ENTER**. Proceed to "[STEP2]".

Change the Amplifier Assignment (Amp Assign)

It is possible to switch the signals being output from the Bi-Wir. or Bi-Amp, FRONT, S.BACK/F.HEIGHT/F.WIDE, F.HEIGHT/F.WIDE, ZONE2 and ZONE3 speaker terminals on the AVR-4810 to suit the speaker environment being used (see page 38 ~ 40 "Amp Assign").

1 Select "Amp Assign" and then press **ENTER**.

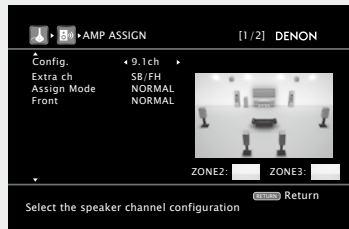

2 Pressing \triangleleft \triangleright , select the MAIN ZONE channel configuration ("Configuration") and then press ∇ .

5.1ch 7.1ch **9.1ch** 11.1ch

3 When selecting "7.1ch" or "9.1ch" in step 2, press \triangleleft \triangleright to select the channels to be used ("Extra Channel"), and then press ∇ .

- When setting "Configuration" to "7.1ch"
 - SB** : When using surround back channel
 - FH** : When using front height channel
 - FW** : When using front wide channel

- When setting "Configuration" to "9.1ch"
 - SB/FH** : When using surround back channel and front height channel
 - SB/FW** : When using surround back channel and front wide channel
 - FH/FW** : When using front height channel and front wide channel

4 Pressing \triangleleft \triangleright , set the usage method for the power amp ("Assign Mode"), and then press ∇ .

- NORMAL** : This is the usual configuration.
- +Z2** : Assign a power amp to ZONE2 audio.
- +Z2+Z3** : Assign a power amp to ZONE2 and ZONE3 audio.
- ALL Z2** : Assign all power amps to ZONE2 audio.
- ALL Z2+Z3** : Assign all power amps to ZONE2 and ZONE3 audio.
- FREE** : Freely assign power amps to the desired channels.

5 Pressing \triangleleft \triangleright , set the connection method for the front speakers ("Front"), and then press ∇ .

- NORMAL** : This is the usual configuration.
- Bi-WIRING** : Bi-wire the front speakers.
- Bi-AMP** : Bi-amp the front speakers.
- 2CH BW** : Bi-wire another front speaker for 2 channel play mode.
- 2CH BA** : Bi-amp another front speaker for 2 channel play mode.

6 The following screen is displayed.

The speaker terminals and the output from the pre-out terminals can be checked on this screen.

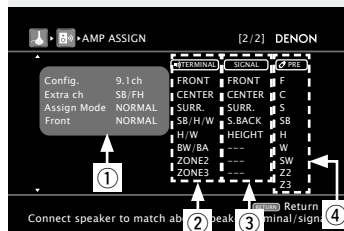

- ① Current settings
 - ② Speaker terminal name
 - ③ Signal being output from speaker terminal
 - ④ Output from pre-out terminal
- * Terminals not being used are greyed out.

* See page 14, 15 on how to connect the speakers.



- When you are using speaker terminals for multi-zone (ZONE2/ZONE3), set "Assign Mode" to "+Z2" or "+Z2+Z3".
- You can set in the same way as described in "Amp Assign" on page 33.

NOTE

Since "Configuration" of AVR-4810 is set to "5.1ch" by default, audio is not output from the surround back speakers. When using the surround back speakers with MAIN ZONE, set "Configuration" to something other than "5.1ch", and then select "SB" in "Extra Channel".

Set the Channels You will not Use (Channel Skip)

If you set the channels you will not use beforehand, those channels will not be measured. Therefore, you can save an amount of time commensurate with that which would have been taken to measure those channels.

1 Select "Channel Skip" and then press **ENTER**.

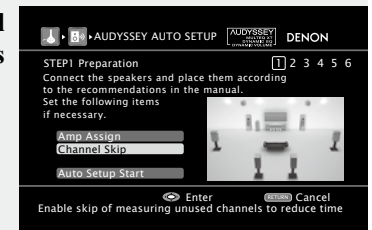

2 Press \triangle ∇ to select a channel, press \triangleleft \triangleright to select the item, and then press **ENTER**.

Configurable channels

- Subwoofer** : Set the subwoofer channel.
- Surround Back** : Set the surround back channel.
- Front Height** : Set the front height channel.
- Front Wide** : Set the front wide channel.

Settings

- Measure** : Measure the selected channel.
- Skip** : Skip the selected channel and do not measure.

* To cancel, press **RETURN**.



Displayed when "Surround Back", "Front Height" and "Front Wide" are set using "Extra Channel" in "Amp Assign".



Make the Optimal Speaker Settings, and Correct the Room Acoustics (Audyssey™ Auto Setup)

3 Perform Audyssey Auto Setup

- Audyssey Auto Setup detects the presence of each speaker and automatically calculates the speaker size, channel level, distance and crossover frequency settings. In addition, acoustical distortions are corrected within the listening area.
- When measuring begins, a test tone is output from each speaker.
- Position and connect all speakers before commencing Audyssey Auto Setup.

STEP2 Speaker Detection

1 Select “Measure” and then press ENTER.

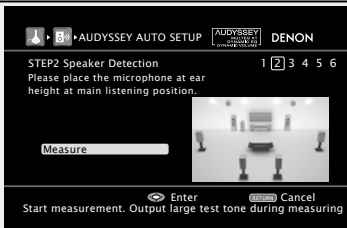

① Measure the subwoofer level

- ※ To stop measuring, select “Cancel” and then press **ENTER**.

- ※ When “Subwoofer” is set to “Skip” with “Channel Skip”, this measurement is not taken, and the process proceeds to “② Measure each speaker”.

② Measure each speaker

- ※ Once the measurements in step ① are complete, the measurements in step ② start automatically.
- ※ The measuring channel changes depending on the setting of “Amp Assign” (page 38 ~ 40) and “Channel Skip” (page 33).

When an error message is displayed, check “Error Messages” for details (page 36).

③ Check the speaker detection results

- When measuring ends, the speaker detection results are displayed.
- ※ Select “Next → Measurement” and press **ENTER** to proceed to “STEP3”.
- ※ Press Δ to select “Retry”, and when you press **ENTER**, measuring at the main listening position starts again.

STEP3 Measurement

2 Move the setup microphone to position 2, select “Measure”, and then press ENTER.

The measurement of the 2nd position starts.

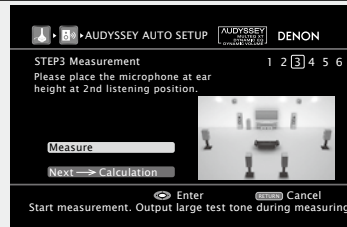

- ※ To skip this step, select “Next → Calculation” and proceed to “STEP4”.

3 Repeat step 2, measuring positions 3 ~ 8.

When measurement of position 8 is completed, a “Measurements finished.” message is displayed.

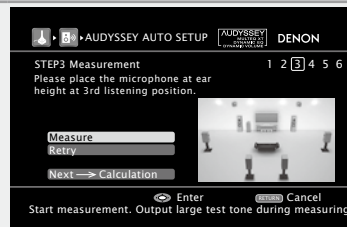

- ※ To skip this step, select “Next → Calculation” and proceed to “STEP4”.
- ※ Measure in at least 6 positions in and around the main listening position. Even though you can complete measurement with at least 6 positions, it is advisable to use more than 6 (a maximum of 8 positions).

STEP4 Calculation

4 On the STEP3 screen, select “Next → Calculation”, and then press ENTER.

Measuring results are analyzed, and the frequency response of each speaker in the listening room is determined.

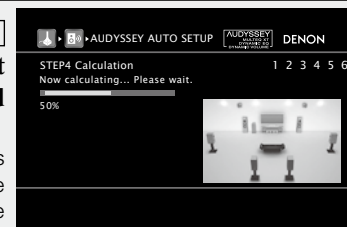

- ※ Analysis takes several minutes to complete. The time required for this analysis depends on the number of speakers connected. The more connected speakers there are, the longer it takes to perform analysis.

STEP5 Check

5 On the STEP5 screen, press Δ / ∇ to select the item you want to check, and then press ENTER.

- Speaker Config. Check
- Distance Check
- Channel Level Check
- Crossover Freq. Check

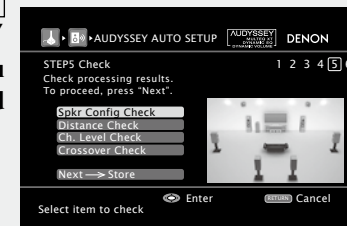

- ※ Subwoofers may measure a greater reported distance than the actual distance due to added electrical delay common in subwoofers.

6 Press Δ / ∇ to select the channel you want to check.

- The measurement result of each speaker is displayed.
- ※ If you want to check another item, press **RETURN**.
- ※ Select “Next → Store” and press **ENTER** to proceed to “STEP6”.



STEP6 Store

7 Select “Store” and then press ENTER.

Save the measuring results.

※ The save operation takes about 30 seconds to complete.

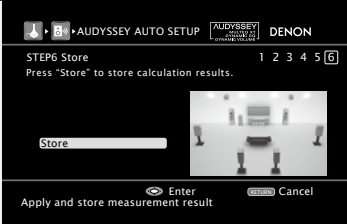

NOTE

During saving of measuring results, be sure not to turn off the power.

8 When the screen shown on the right appears, unplug the setup microphone from the AVR-4810 SETUP MIC jack.

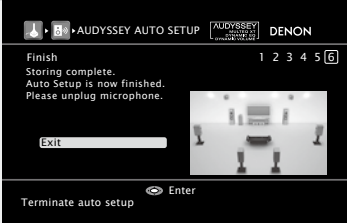

9 Select “Exit” and then press ENTER.

Exiting the GUI Menu

Press **MENU** while the GUI menu is displayed.
The GUI menu display disappears.

NOTE

After performing Audyssey Auto Setup, do not change the speaker connections or subwoofer volume. In event of a change, perform Audyssey Auto Setup again.



- If there is a disparity between the results and the connection status, or if an error message is displayed, check the error message against the errors listed in the “Error Messages” section (page 36) and perform Audyssey Auto Setup again.
- If the result still differs from the actual connection status after remeasurement or the error message still appears, it is possible that the speakers are not connected properly. Turn the AVR-4810 off, check the speaker connections and repeat the measurement process from the beginning. Turn the AVR-4810 off, check the speaker connections and repeat the measurement process from the beginning.
- If you change a speaker position or orientation, perform Audyssey Auto Setup again to obtain optimal equalizer correction.



Make the Optimal Speaker Settings, and Correct the Room Acoustics (Audyssey™ Auto Setup)

Error Messages

An error message is displayed if it was not possible to complete Audyssey Auto Setup due to speaker placement, the measurement environment, etc. If this happens, check the relevant items, be sure to take the necessary measures, then perform Audyssey Auto Setup over again.

NOTE
Be sure to turn off the power before checking speaker connections.

When Performing Audyssey Auto Setup Over Again
Press $\Delta \nabla$ to select "Retry", and then press **ENTER**.

When Measuring has Stopped
Press **RETURN**, the "Cancel auto setup?" prompt is displayed.
Press $\triangleleft \triangleright$ and select "Yes", then press **ENTER**.

Error messages (examples)	Error contents	Measures
	<ul style="list-style-type: none"> Correct measurement is not possible due to inappropriate subwoofer volume. 	<ul style="list-style-type: none"> When using a subwoofer with built-in amplifier (active type), use "SW Level Matching" to adjust the subwoofer volume (page 37). When using a subwoofer without a built-in amplifier, select "Skip", and then press ENTER.
	<ul style="list-style-type: none"> Included setup microphone is not connected. Not all speakers could be detected. The front L speaker was not properly detected. 	<ul style="list-style-type: none"> Connect the included setup microphone to the SETUP MIC jack of the AVR-4810. Check the speaker connections.
	<ul style="list-style-type: none"> Too much noise in the room for accurate measurements to be made. Speaker or subwoofer sound is too low for accurate measurements to be made. 	<ul style="list-style-type: none"> Either turn off any device generating noise or move it away. Perform again when the surroundings are quieter. Check the speaker installation and the direction in which the speakers are facing. Adjust the subwoofer's volume.
	<ul style="list-style-type: none"> Displayed speaker could not be detected. 	<ul style="list-style-type: none"> Check the connections of the displayed speaker.
	<ul style="list-style-type: none"> Displayed speaker connected with the polarities reversed. 	<ul style="list-style-type: none"> Check the polarities of the displayed speaker. For some speakers, this error message may be displayed even if the speaker is properly connected. If you are sure the connection is correct, press $\Delta \nabla$ to select "Skip", then press ENTER.

Subwoofer Level Error Message and How to Adjust

The optimal level of the subwoofer channel is 75 dB. During subwoofer level measurement (3:Perform Audyssey Auto Setup, "STEP2 : Speaker Detection" (page 34), 1 - ①), an error message is displayed when the subwoofer level is outside the 72 ~ 78 dB range. When using a subwoofer with built-in amplifier (active type), adjust the subwoofer volume so that the subwoofer level is within the 72 ~ 78 dB range.

1 Select "SW Level Matching" and then press ENTER.

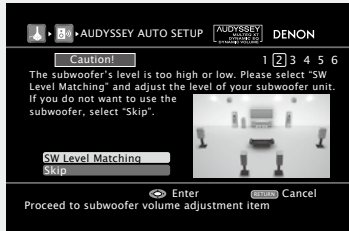

2 Select "SW Test Start" and then press ENTER.

Subwoofer level measurement begins. During measuring, a "Testing ..." message is displayed. The measured level appears on the level indicator after about 3 ~ 5 seconds.

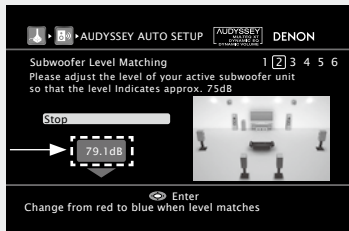
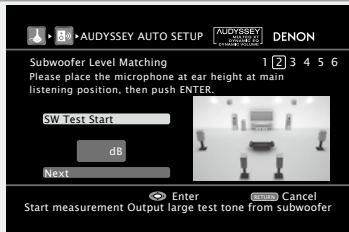

- ※ If the measured level is outside the 72 ~ 78 dB range, the level indicator is red.
- ※ When measuring stops, press **ENTER**.

3 Adjust the volume control on your subwoofer so that the measured level is within the 72 ~ 78 dB range.



- ※ If the measured level is within the 72 ~ 78 dB range, the level indicator is blue.

4 When the measured level is within the 72 ~ 78 dB range, press ENTER.

5 Select "Next" and then press ENTER.

Proceed to "3:Perform Audyssey Auto Setup, [STEP2] : Speaker Detection" (page 34), 1 - ②).

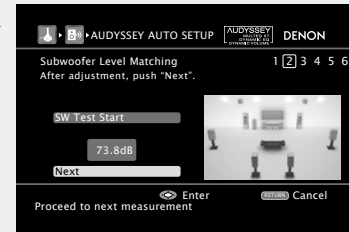

Check the Measuring Results and Equalizer Type after Audyssey Auto Setup (Parameter Check)

This is displayed after Audyssey Auto Setup is completed.

1 Press ∇ to select "Parameter Check", and then press ENTER or \triangleright .

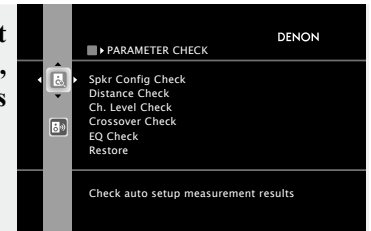

2 Press $\Delta\nabla$ to select the item you want to check, and then press ENTER or \triangleright .

- Speaker Config. Check
- Distance Check
- Channel Level Check
- Crossover Freq. Check
- EQ Check

3 Press $\Delta\nabla$ to select the channel you want to check. The measurement result of each speaker is displayed.

- ※ When you selected "EQ Check" in step 2, press $\Delta\nabla$ to select the Correction curve you want to check ("Audyssey" or "Audyssey Flat").
- ※ When you want to check another item, press **RETURN**. Pressing **RETURN** returns you to step 2; from there, proceed to steps 2 and 3.



If you set "Restore" to "Yes", you can return to Audyssey Auto Setup measurement result (value calculated at the start by MultEQ.XT) even when you have changed each setting manually.





Making Detailed Settings (Manual Setup)



For details on how to select, set and cancel settings for each menu, see "GUI Menu Operation" (page 29).

Set when changing Audyssey Auto Setup settings, or when changing the audio, video, display or other settings.

- If you change the speaker settings after performing Audyssey Auto Setup, it will not be possible to select MultEQ® XT, Dynamic EQ™ and Dynamic Volume™ (pages 83, 84).
- Can be used without changing the settings. Please set if necessary.
- See pages 28, 29 for "GUI Menu Map" and "GUI Menu Operation".

Items that can be set with the Manual Setup procedure

- Making the speaker settings (Speaker Setup) page 38
- Making the HDMI settings (HDMI Setup) page 42
- Making the audio settings (Audio Setup) page 43
- Making the network settings (Network Setup) page 45
- Making the Multi-zone settings (Zone Setup) page 51
- Making other settings (Option Setup) page 52
- Making language settings (Language) page 56



Making the Speaker Settings (Speaker Setup)



Default settings are underlined.

Perform when setting the speakers manually or when changing settings made in Audyssey Auto Setup.

Change power amp assignment to suit the speaker system configuration (Amp Assign)

Examples of Amp Assign Menu Screen Displays

[1st page]

Set items 1 ~ 4 referring to "Steps for setting "Amp Assign" (page 39, 40)

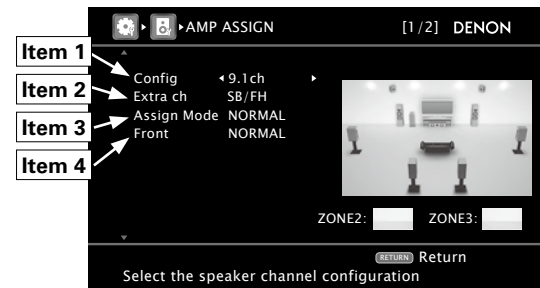

[2nd page]

The signal being output by each speaker can change according to "Amp Assign" setting. The speaker terminals and the output from the pre-out terminals can be checked on this screen.

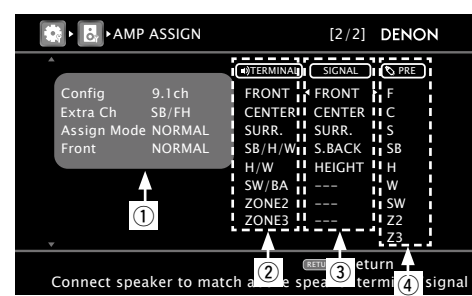

- ① Current settings
 - ② Speaker terminal name
 - ③ Signal being output from speaker terminal
 - ④ Output from pre-out terminal
- * Terminals not being used are greyed out.



See also page 14, 15 for how to connect the speakers.

❑ Steps for setting "Amp Assign"

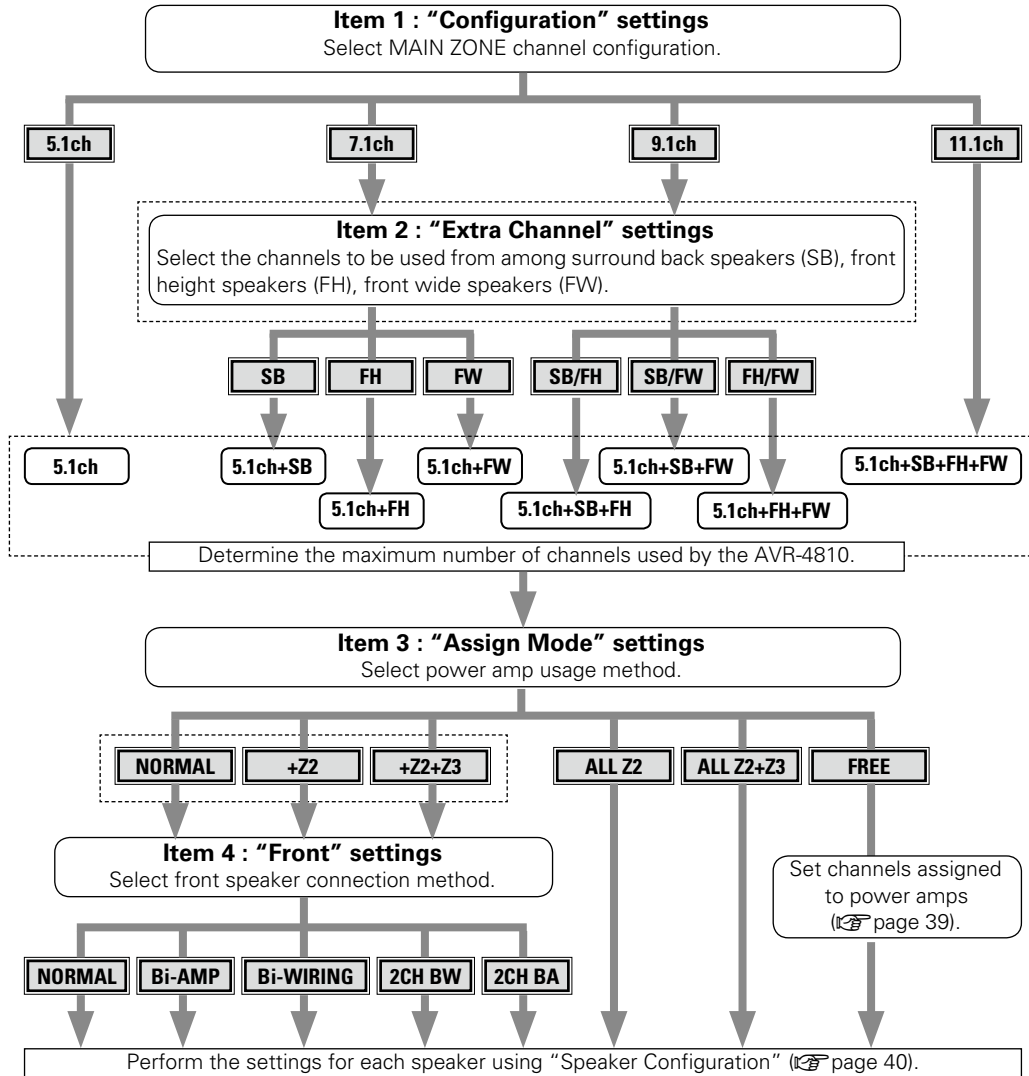

See page 40 for details of the settings in "Assign Mode" and "Front".

❑ "FREE" settings

It is possible to freely select the signal being output from each speaker terminal (except for "Bi-Wir./Bi-Amp", "ZONE2", "ZONE3") when "Assign Mode" is set to "FREE". In the screen below, press $\Delta \nabla$ to select the speaker terminal, then press $\triangleleft \triangleright$ to select the output signal.

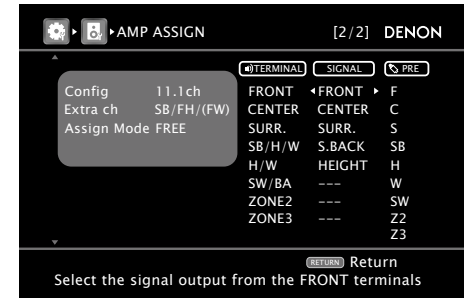

Refer to the chart below for the signals that can be output to each speaker terminal.

		Speaker terminal				
		FRONT	CENTER	SURROUND	S.BACK / F.HEIGHT / F.WIDE	F.HEIGHT / F.WIDE
Signal	FRONT	FRONT	CENTER	FRONT	FRONT	FRONT
	CENTER		S.BACK *1	CENTER	CENTER	CENTER
	SURROUND		ZONE2	SURROUND	SURROUND	SURROUND
	S.BACK *1		ZONE3	S.BACK *1	S.BACK *1	S.BACK *1
	F.HEIGHT *2		---	F.HEIGHT *2	F.HEIGHT *2	F.HEIGHT *2
	F.WIDE *3		---	F.WIDE *3	F.WIDE *3	F.WIDE *3
	ZONE2		---	ZONE2	ZONE2	ZONE2
	ZONE3		---	ZONE3	ZONE3	ZONE3
	Z2/Z3(MONO)		---	Z2/Z3(MONO)	Z2/Z3(MONO)	Z2/Z3(MONO)
	---		---	---	---	---

--- : No channel output

*1 : Can be selected when "SB" is set in "Extra Channel".

*2 : Can be selected when "FH" is set in "Extra Channel".

*3 : Can be selected when "FW" is set in "Extra Channel".





- When "Z2/Z3 (MONO)" is selected, ZONE2 and ZONE3 use monaural audio. The ZONE2 mono audio is output from the speaker terminal's L ch and the ZONE3 mono audio is output from the R ch.
- When selecting "S.BACK" for the center speaker terminal output, set the "Speaker Configuration" – "Surround Back" (page 40) to "1spkr".
- When selecting "ZONE2" or "ZONE3" for the center speaker terminal, set the "Zone Setup" – "Channel" (page 51) to "Mono".





Making Detailed Settings (Manual Setup)

Setting items	Setting contents
<p>Amp Assign Change the power amp assignment to suit the speaker system configuration.</p>	<p>Configuration : Select MAIN ZONE channel configuration. • 5.1ch / 7.1ch / 9.1ch / 11.1ch</p> <p>Extra Channel : Select the channels to be used from among surround back speakers (SB), front height speakers (FH), front wide speakers (FW).</p> <p><input type="checkbox"/> When setting "Configuration" to "7.1ch" • SB / FH / FW</p> <p><input type="checkbox"/> When setting "Configuration" to "9.1ch" • SB/FH / SB/FW / FH/FW</p> <p>Assign Mode : Select power amp usage method. • NORMAL : This is the usual configuration. • +Z2 : Assign a power amp to ZONE2 audio. • +Z2+Z3 : Assign a power amp to ZONE2 and ZONE3 audio. • ALL Z2 : Assign all power amps to ZONE2 audio. • ALL Z2+Z3 : Assign all power amps to ZONE2 and ZONE3 audio. • FREE : Freely assign power amps to the desired channels.</p> <p>Front : Select front speaker connection method. • NORMAL : This is the usual configuration. • Bi-WIRING : Bi-wire the front speakers. • Bi-AMP : Bi-amp the front speakers. • 2CH BW : Bi-wire another front speaker for 2 channel play mode. • 2CH BA : Bi-amp another front speaker for 2 channel play mode.</p>
<p>Speaker Configuration Select speaker configuration and size (bass reproduction capability).</p> <p>NOTE Select "Large" or "Small" not according to the physical size of the speaker but according to the low frequency reproduction capabilities based on the frequency set at "Crossover Frequency" (☞ page 42).</p>	<p>Front : Set the front speaker size. • Large : Use of a large speaker that can adequately playback low frequencies. • Small : Use of a small speaker that has inadequate playback capacity for low frequencies.</p> <p> When "Subwoofer" is set to "No", "Front" can automatically set to "Large".</p> <p> When "Front" is set to "Small", "Center", "Surround", "Surround Back", "Front Height" and "Front Wide" can not be set to "Large".</p> <p>Center : Set the presence and size of the center speaker. • Large : Use of a large speaker that can adequately playback low frequencies. • Small : Use of a small speaker that has inadequate playback capacity for low frequencies. • None : Select when a center speaker is not connected.</p> <p> "Large" is not displayed when "Front" is set to "Small".</p>

Setting items	Setting contents
<p>Speaker Configuration (Continued)</p>	<p>Subwoofer : Set the presence of a subwoofer. • Yes : Use a subwoofer. • No : Select when a subwoofer is not connected.</p> <p> When "Front" is set to "Small", "Subwoofer" can automatically set to "Yes".</p> <p>Surround : Set the presence and size of the surround speakers. • Large : Use of a large speaker that can adequately playback low frequencies. • Small : Use of a small speaker that has inadequate playback capacity for low frequencies. • None : Select when the surround speakers are not connected.</p> <p></p> <p> When "Surround" is set to "Large", "Surround Back", "Front Height" and "Front Wide" can be set to "Large".</p> <p> When "Surround" is set to "None", "Surround Back", "Front Height" and "Front Wide" can automatically set to "None".</p> <p>Surround Back : Set the presence, size and number of surround back speakers. • Large : Use of a large speaker that can adequately playback low frequencies. • Small : Use of a small speaker that has inadequate playback capacity for low frequencies. • None : Select when the surround back speakers are not connected.</p> <p>• 2spkr : Use two surround back speakers. • 1spkr : Use only one surround back speaker. When you select this setting, connect the surround back speaker to the left (L) channel.</p> <p></p> <p> When "Configuration" is set to "5.1ch" in the "Amp Assign" settings or when "SB" is not selected using "Extra Channel", no settings can be made for "Surround Back".</p> <p> Even when the Surround Back Speaker setting is other than "None", sound may not be emitted from the surround back speaker, depending on the playback source. In this case, "Surround Parameters" – "Surround Back" setting other than "OFF" (☞ page 82).</p>



Setting items	Setting contents
Speaker Configuration (Continued)	<p>Front Height : Set the presence and size of the front height speakers.</p> <ul style="list-style-type: none"> • Large : Use of a large speaker that can adequately playback low frequencies. • Small : Use of a small speaker that has inadequate playback capacity for low frequencies. • None : Select when the front height speakers are not connected. <p> When "Configuration" is set to "5.1ch" in the "Amp Assign" settings (page 40) or when "FH" is not selected using "Extra Channel", no settings can be made for "Front Height".</p> <hr/> <p>Front Wide : Set the presence and size of the front wide speakers.</p> <ul style="list-style-type: none"> • Large : Use of a large speaker that can adequately playback low frequencies. • Small : Use of a small speaker that has inadequate playback capacity for low frequencies. • None : Select when the front wide speakers are not connected. <p> When "Configuration" is set to "5.1ch" in the "Amp Assign" settings (page 40) or when "FW" is not selected using "Extra Channel", no settings can be made for "Front Wide".</p>
Bass Setting Settings for subwoofer and LFE signal range playback.	<p>Subwoofer Mode : Select low range signals to be reproduced by subwoofer.</p> <ul style="list-style-type: none"> • LFE : The low range signal of the channel set to "Small" speaker size is added to the LFE signal output from the subwoofer. • LFE+Main : The low range signal of all channels is added to the LFE signal output from the subwoofer. <p> This can be set when "Speaker Configuration" – "Subwoofer" (page 40) is set to "Yes".</p> <ul style="list-style-type: none"> • Play music or a movie source and select the mode offering the strongest bass. • Select "LFE+Main" if you want the bass signals to always be produced from the subwoofer. <hr/> <p>LPF for LFE : Set LFE signal playback range.</p> <ul style="list-style-type: none"> • 80Hz / 90Hz / 100Hz / 110Hz / 120Hz / 150Hz / 200Hz / 250Hz

Setting items	Setting contents
Distance Set distance from listening position to speakers. Measure beforehand the distance from the listening position to each speaker.	<p>Meters / Feet : Set the unit of distance.</p> <p>Step : Set the minimum variable width of the distance.</p> <ul style="list-style-type: none"> • 0.1m / 0.01m • 1ft / 0.1ft <p>Default : Reset all distance settings to factory default.</p> <ul style="list-style-type: none"> • Yes : Reset to the defaults. • No : Do not reset to the defaults. <p> When you select "Default" and press ENTER, the "Return all settings to the default?" prompt is displayed. Select either "Yes" or "No", and press ENTER.</p> <hr/> <p>Front L / Front R / Center / Subwoofer / Surround L / Surround R / Surr. Back L* / Surr. Back R* / Front Height L / Front Height R / Front Wide L / Front Wide R : Select the speaker.</p> <p>*: When the "Speaker Configuration" – "Surround Back" setting (page 40) is set to "1spkr", "Surr. Back" is displayed.</p> <ul style="list-style-type: none"> • 0.00m ~ 18.00m / 0.0ft ~ 60.0ft : Set the distance. <p> Speakers set to "None" in "Speaker Configuration" (page 40) are not displayed.</p> <ul style="list-style-type: none"> • The speakers that can be selected differ depending on the "Amp Assign" (page 40) and "Speaker Configuration" (page 40) settings. • Default settings : Front / Center / Subwoofer / Front Height / Front Wide : 3.60 m (12.0 ft) Surround / Surround Back : 3.00 m (10.0 ft) • Set the difference in the distance between the speakers to less than 6.0 meters (20 feet).
Channel Level Set the volume of the test tone to be the same when it is output from each speaker.	<p>Test Tone : Output test tone.</p> <ul style="list-style-type: none"> • Front L / Front Height L / Center / Front Height R / Front R / Front Wide R / Surround R / Surr. Back R* / Surr. Back L* / Surround L / Front Wide L / Subwoofer : Select the speaker. <p>* : When the "Speaker Configuration" – "Surround Back" setting (page 40) is set to "1spkr", "Surr. Back" is displayed.</p> <ul style="list-style-type: none"> • -12dB ~ +12dB (0dB) : Adjust the volume. <p> Speakers set to "None" in the "Speaker Configuration" (page 40) settings are not displayed.</p> <ul style="list-style-type: none"> • When  is pressed while the subwoofer volume is set to "-12 dB", the "Subwoofer" setting switches to "OFF". • When a headphones jack is inserted in the PHONES terminal of the AVR-4810, the "Channel Level" is not displayed. • You can also press CHANNEL LEVEL to set (page 91 "Adjust the Volume of the Different Speakers").

See overleaf

Main remote control unit operation buttons



:Displaying the menu
Cancel the menu



:Moves the cursor
(Up/Down/Left/Right)





:Confirm the setting



:Return to previous menu

Making Detailed Settings (Manual Setup)

Setting items	Setting contents
Channel Level (Continued)	Default : Reset all distance settings to factory default. <ul style="list-style-type: none"> • Yes : Reset to the defaults. • No : Do not reset to the defaults.
Crossover Frequency Outputs at below set frequency, each speaker's bass signal output from the subwoofer. Set this according to the low frequency reproduction capabilities of the speakers you are using.	40Hz / 60Hz / <u>80Hz</u> / 90Hz / 100Hz / 110Hz / 120Hz / 150Hz / 200Hz / 250Hz : Set the crossover frequency. Advanced : Specify crossover frequency for each speaker. <ul style="list-style-type: none"> • Front / Center / Surround / Surround Back / Front Height / Front Wide : Select the speaker. • 40Hz / 60Hz / 80Hz / 90Hz / 100Hz / 110Hz / 120Hz / 150Hz / 200Hz / 250Hz : Set the crossover frequency.  <ul style="list-style-type: none"> • Can be set when the "Speaker Configuration" – "Subwoofer" (page 40) setting is "Yes", or when you have a speaker that is set to "Small". • Always set the crossover frequency to "80Hz". When using small speakers, however, we recommend setting the crossover frequency to a higher frequency. • For speakers set to "Small", sound below the crossover frequency is cut from the sound output. The cut bass sound is output from the subwoofer or front speakers. • The speakers that can be set when "Advanced" is selected differ according to the "Subwoofer Mode" setting (page 41). <ul style="list-style-type: none"> • When "LFE" is selected, speakers set to "Small" at "Speaker Configuration" can be set. If the speakers are set to "Large", "Full Band" is displayed and the setting cannot be made. • If set to "LFE+Main", this setting can be made regardless of the speaker size.
Speaker Impedance Set the impedance of connected speakers.	8Ω/ohms : Select when the impedance of the connected speaker is 8 Ω/ohms or more. 6Ω/ohms : Select when the impedance of the connected speaker is at least 6 Ω/ohms but less than 8 Ω/ohms.  Check the speaker impedance (Ω) shown on the back of your speakers or in the instruction manual beforehand.







Making the HDMI Settings (HDMI Setup)



Default settings are underlined.

Make settings for HDMI video/audio output.

Setting items	Setting contents
RGB Range Set the video range of RGB output from the HDMI terminal.	<u>Normal</u> : Output with RGB video range (16 (black) to 235 (white)). Enhanced : Output with RGB video range (0 (black) to 255 (white)).  This setting is valid when using a TV equipped with a DVI terminal.
Vertical Stretch Expand image signal in vertical direction.	<u>ON</u> : Expand image signal in vertical direction. OFF : Do not expand signal in vertical direction.  This setting is valid with respect to the HDMI output when using an HDMI-compatible TV. When not using an HDMI-compatible TV, it is valid with respect to the analog output.
Auto Lip Sync Automatic compensation for timing shift in audio and video output.	<u>ON</u> : Compensated. OFF : Not compensated.
HDMI Audio Out Select HDMI audio output device.	<u>Amp</u> : Playback through speakers connected to the receiver. TV : Playback through TV connected to the receiver.  When the HDMI control function is operating, the setting of audio playback in the connected TV takes priority (page 90 "HDMI Control Function").
Monitor Out Make settings for HDMI monitor output.	<u>Auto (Dual)</u> : The presence of a TV connected to the MONITOR 1 or MONITOR 2 terminal is detected automatically, and that TV connection is used. Monitor 1 : A TV connected to the MONITOR 1 terminal is always used. Monitor 2 : A TV connected to the MONITOR 2 terminal is always used.  <ul style="list-style-type: none"> • If both the Monitor 1 and 2 connectors are connected and "Resolution" (page 60) is set to "Auto", the signals are output with a resolution compatible with both TV. • With "Resolution" (page 60) not set to "Auto", check whether the TV you are using is compatible with the resolution under "HDMI Information" – "Monitor 1" and "Monitor 2" (page 87). • Depending on the monitor you have connected, the display may not be correct when you set to "Auto (Dual)". In such a case, set to either "Monitor 1" or "Monitor 2". • You can also set "Monitor Out" by pressing M.SEL on the main remote control unit.



Setting items	Setting contents
HDMI Control External devices can be controlled from the AVR-4810 and the AVR-4810 can be controlled from external devices.	<p>Control</p> <ul style="list-style-type: none"> • ON : Use HDMI control function • OFF : Do not use HDMI control function <p> When a device that is not compatible with the HDMI control function is connected, set "Control" to "OFF".</p> <p>NOTE</p> <ul style="list-style-type: none"> • When "Control" is set to "ON", it consumes more standby power. • When not using this unit for a long period, we recommend that you press POWER on the main unit to turn off the power. • "HDMI Control" does not work when the power to the equipment is off. Either power on or set to standby. <p>Standby Source : Set the HDMI connector for HDMI signal input during standby.</p> <ul style="list-style-type: none"> • Last : Standby with last used input source during power on. • HDMI1 / HDMI2 / HDMI3 / HDMI4 / HDMI5 / HDMI6 : The standby mode is set at the input source assigned to the respective. <p> This can be set when "Control" is set to "ON".</p> <p>Control Monitor : Set the HDMI MONITOR terminal to output the HDMI control signal.</p> <ul style="list-style-type: none"> • Monitor 1 : Output from the MONITOR 1 terminal. • Monitor 2 : Output from the MONITOR 2 terminal. <p> This can be set when "Control" is set to "ON".</p> <p>Power Off Control : The power of the AVR-4810 and external device turn off together.</p> <ul style="list-style-type: none"> • ON : Interlock. • OFF : Do not interlock. <p> This can be set when "Control" is set to "ON".</p>
 • Please consult the operating instructions for each connected device to check the settings. • Refer to "HDMI Control Function" (page 90) for more information about the HDMI control function. • When the "Control" setting has been changed, always turn off the power to the connecting devices afterwards and then turn back on.	
NOTE The HDMI control function controls operations of a TV that is compatible with the HDMI control function. Make sure that the TV and HDMI are connected when you perform HDMI control.	



Making the Audio Settings (Audio Setup)



Default settings are underlined.

Make settings for audio playback.

Setting items	Setting contents
EXT. IN Setup Setup playback method for analog signals inputted from external input connectors (EXT. IN).	<p>Subwoofer Level : Set playback level of subwoofer signal input from the external input connector (EXT. IN).</p> <ul style="list-style-type: none"> • +15dB : This is the recommended level. • +10dB / +5dB / 0dB : Select the level according to the player being used.
2ch Direct/Stereo Make speaker settings for 2-channel mode playback.	<p>Setting : Select the method for setting the speakers used in the 2-channel direct and stereo playback modes.</p> <ul style="list-style-type: none"> • Basic : The settings at "Speaker Setup" (page 40) are applied. • Custom : Make separate settings for 2-channel. <p>Front : Set the front speaker size.</p> <ul style="list-style-type: none"> • Large : Use of a large speaker that can adequately playback low frequencies. • Small : Use of a small speaker that has inadequate playback capacity for low frequencies. <p> If "Speaker Configuration" – "Subwoofer" (page 40) is set to "No", the setting is automatically set to "Large".</p> <p>Subwoofer : Set the presence of a subwoofer.</p> <ul style="list-style-type: none"> • Yes : Use a subwoofer. • No : Select when a subwoofer is not connected. <p> If "Speaker Configuration" – "Subwoofer" (page 40) is set to "No", the setting is automatically set to "No". If the "Front" setting is "Small", the setting is automatically "Yes".</p> <p>SW Mode : Select low range signal to be reproduced by subwoofer.</p> <ul style="list-style-type: none"> • LFE : When the "2ch Direct/Stereo" – "Front" setting is set to "Large", the LFE signal alone is output from the subwoofer. Also, when the "2ch Direct/Stereo" – "Front" setting is set to "Small", the front channel low range signal is added to the LFE signal output from the subwoofer. • LFE+Main : The front channel low range signal is added to the LFE signal output from the subwoofer. <p> This can be set when "2ch Direct/Stereo" – "Subwoofer" is set to "Yes".</p>

See overleaf

Main remote control unit operation buttons



:Displaying the menu
Cancel the menu



:Moves the cursor
(Up/Down/Left/Right)







:Confirm the setting



:Return to previous menu

Making Detailed Settings (Manual Setup)

Setting items	Setting contents
2ch Direct/Stereo (Continued)	<p>Crossover : Outputs at below set frequency, each speaker's bass signal output from the subwoofer.</p> <ul style="list-style-type: none"> • 40Hz / 60Hz / 80Hz / 90Hz / 100Hz / 110Hz / 120Hz / 150Hz / 200Hz / 250Hz <p> This can be set when "2ch Direct/Stereo" – "Subwoofer" is set to "Yes".</p> <ul style="list-style-type: none"> • If the "2ch Direct/Stereo" – "Front" setting is "Large" and the "SW Mode" setting is "LFE", "Full Band" is displayed and the setting cannot be made. <p>Distance FL / Distance FR : Select the speaker.</p> <ul style="list-style-type: none"> • 0.00m ~ 18.00m (3.60m) / 0.0ft ~ 60.0ft (12.0ft) : Set the distance to the speaker. <p> Set so that the difference between the front left speaker and front right speaker distances is 6.0 m (20.0 ft) or less.</p> <p>Level FL / Level FR : Select the speaker.</p> <ul style="list-style-type: none"> • -12.0dB ~ +12.0dB (0.0dB) : Adjust the level of each channel.
Auto Surround Mode Make setting for memorizing surround mode setting for each input signal type.	<p>ON : Memorize settings. Automatically play with the last used surround mode.</p> <p>OFF : Do not memorize settings. Surround mode does not change according to input signal.</p> <p> The auto surround mode function lets you store in the memory the surround mode last used for playing the four types of input signals listed below.</p> <ol style="list-style-type: none"> ① Analog and PCM 2-channel signals ② Dolby Digital and DTS 2-channel signals ③ Dolby Digital and DTS multi-channel signals ④ Multi-channel signals other than Dolby Digital and DTS (PCM, DSD, etc.) <ul style="list-style-type: none"> • When playing in the PURE DIRECT, the surround mode does not change even if the input signal is changed.

Setting items	Setting contents
EQ Customize Set so that unused equalizer settings are not displayed when MULTEQ XT on the main remote control unit is pressed.	<p>Audyssey Byp. L/R : Set when not using "Audyssey Byp L/R" equalizer.</p> <ul style="list-style-type: none"> • Used : Use. • Not Used : Do not use. <p> Set so that "Audyssey Byp. L/R" settings can be made when Audyssey Auto Setup is performed.</p> <p>Audyssey Flat : Set when not using "Audyssey Flat" equalizer.</p> <ul style="list-style-type: none"> • Used : Use. • Not Used : Do not use. <p> Set so that "Audyssey Flat" settings can be made when Audyssey Auto Setup is performed.</p> <p>Manual : Set when not using the "Manual" equalizer.</p> <ul style="list-style-type: none"> • Used : Use. • Not Used : Do not use.
Equalizer settings for which "Not Used" is set with the Quick Select function cannot be stored and called out.	





Making the Network Settings (Network Setup)

GUI

Default settings are underlined.

Make network settings.

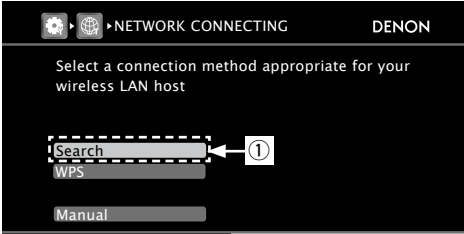
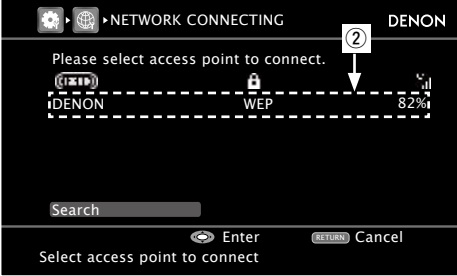
Setting items	Setting contents
Network Connecting Make settings for wired or wireless LAN.	<div style="border: 1px solid black; padding: 5px; text-align: center;"> Wireless LAN settings </div> <p>Use this procedure to configure the Wireless LAN settings.</p> <ol style="list-style-type: none"> Fitting a rod antenna (☞ page 25 "Connecting to a Home Network (LAN)"). ※ If a LAN cable is connected, remove it. Turn on the AVR-4810 (☞ page 27 "Turning the Power On"). Set the access point at the "Network Connecting". When searching access points to connect automatically, refer to "Automatic settings". When searching access points to connect manually, refer to "Manual settings". <p>Automatic settings</p> <div style="display: flex; flex-direction: column; align-items: center;">   </div> <ol style="list-style-type: none"> On the GUI menu, select "Network Connecting" – "Search" and press ENTER. The access point you have set is displayed. Use $\Delta \nabla$ to select the access point, and then press ENTER. The DHCP function is disabled.

Making Detailed Settings (Manual Setup)

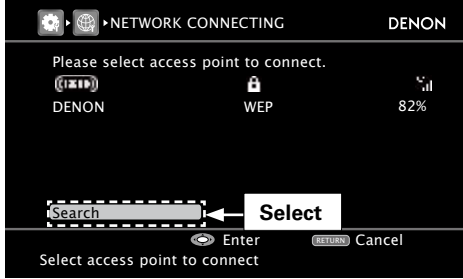
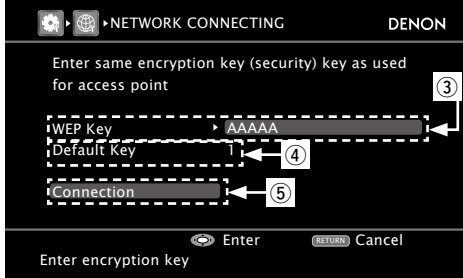
Setting items	Setting contents
Network Connecting (Continued)	<p>※ If the access points are repeat search, use ∇ to select the "Search" and press ENTER.</p> <div style="display: flex; flex-direction: column; align-items: center;">   </div> <ol style="list-style-type: none"> If there is an encryption setting for the access point you selected in step ②, enter same encryption key as used for the access point. (If there is no encryption setting, proceed to step ⑤.) <p>Use $\Delta \nabla \leftarrow \rightarrow$ to input the "Key" (encryption key) and press ENTER. Enter the same encryption key as used for the access point. The types of characters that can be input are as shown below.</p> <div style="border: 1px solid black; padding: 5px; margin: 10px 0;"> <p>[Lower case characters] abcdefghijklmnopqrstuvwxyz [Upper case characters] ABCDEFGHIJKLMNOPQRSTUVWXYZ [Symbols] ! " # \$ % & ' () * + , - . / : ; < = > ? @ [\] ^ _ ` { } ~ [Numbers] 0 1 2 3 4 5 6 7 8 9 (Space)</p> </div> <ul style="list-style-type: none"> You can change the character type when you press SEARCH on the main remote control unit or MENU during character input. When no security settings have been used in the Internet connection settings, this step is not necessary. <ol style="list-style-type: none"> When encryption is by "WEP", select the "Default Key" using ∇, and then press $\leftarrow \rightarrow$. 1 / 2 / 3 / 4 : Select the same default key as used for the access point. This should normally be set to "1".

See overleaf

Main remote control unit operation buttons



:Displaying the menu
Cancel the menu



:Moves the cursor
(Up/Down/Left/Right)



:Confirm the setting



:Return to previous menu

Getting Started
Connections
Settings
Playback
Multi-zone
Remote Control
Information
Troubleshooting
Specifications

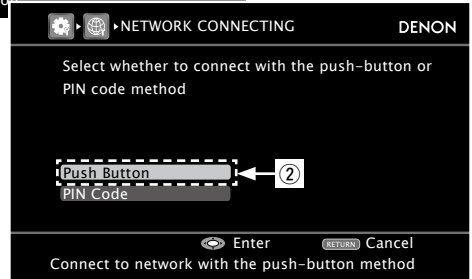

Making Detailed Settings (Manual Setup)

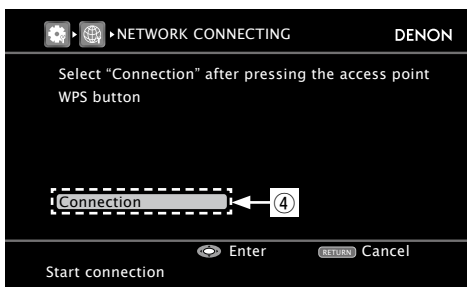
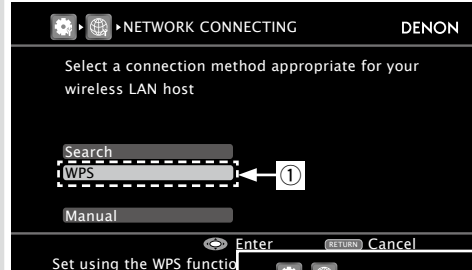
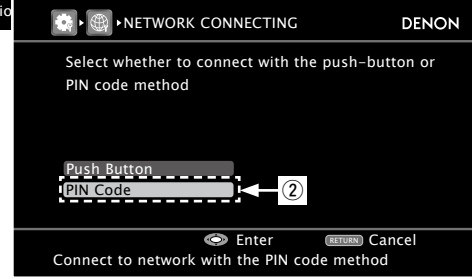
Setting items	Setting contents
Network Connecting (Continued)	<p>⑤ Use ▾ to select "Connection" and press ENTER. Network connection starts. When connection is established with the access point, "Connection completed." is displayed.</p>  <p>AVR-4810 performs automatic network setup due to the DHCP function. When connecting to a network without a DHCP function, you will need to manually configure the IP address. For details, see page 48 "Wired LAN settings" in step 3.</p> <p>❑ How to connect with WPS (Push-button method) Use access points (routers) equipped with WPS functions. See the router user manual for details.</p>   <p>① Select "WPS" and press ENTER. ② Select "Push Button" and press ENTER.</p>

Setting items	Setting contents
Network Connecting (Continued)	<p>③ Press WPS for the target access point. ④ Select "Connection" and press ENTER. When connection is established with access point, "Connection completed" is displayed.</p>  <p>✎ This WPS (push-button) setup screen can be displayed directly by pressing and holding ◀ and ▶ on the main unit for at least 3 seconds.</p> <p>❑ How to connect with WPS (PIN code method) Use access points (routers) equipped with WPS functions. See the router user manual for details.</p>   <p>① Select "WPS" and press ENTER. ② Select "PIN Code" and press ENTER.</p>

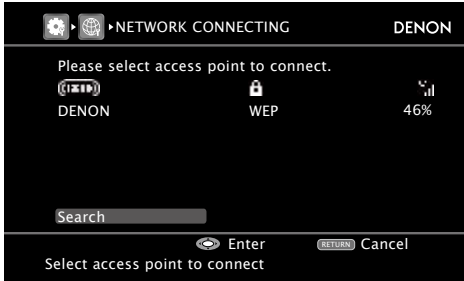
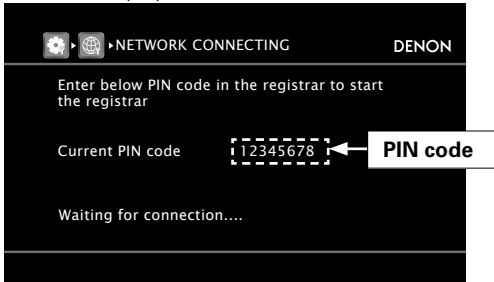
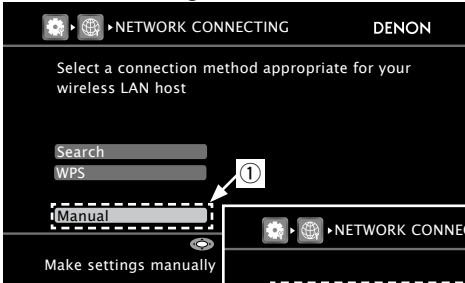
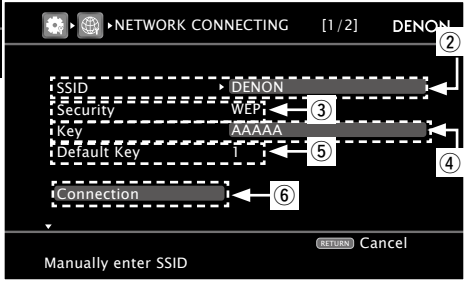

Setting items	Setting contents
Network Connecting (Continued)	<p>The access point is displayed.</p>  <p>③ Use Δ ∇ to select the access point and press ENTER. PIN code number is displayed.</p>  <p>④ Set the PIN code displayed on the GUI screen to registrar. When connection is established with access point, "Connection completed" is displayed.</p> <p>Manual settings</p>  

Setting items	Setting contents
Network Connecting (Continued)	<p>① On the GUI menu, select "Network Connecting" – "Manual" and press ENTER.</p> <p>② Use Δ ∇ \triangleleft \triangleright to input the name of the wireless network (SSID) and press ENTER. The types of characters that can be input are as shown below.</p> <div style="border: 1px solid black; padding: 5px;"> <p>[Lower case characters] abcdefghijklmnopqrstuvwxyz [Upper case characters] ABCDEFGHIJKLMNOPQRSTUVWXYZ [Symbols] ! " # \$ % & ' () * + , - . / : ; < = > ? @ [\] ^ _ ` { } ~ [Numbers] 0123456789 (Space)</p> </div> <p> You can change the character type when you press SEARCH on the main remote control unit or MENU during character input.</p> <p>③ Use Δ ∇ to select the Security and press ∇. None : Select if not encrypted. Can also be used even without encryption, through we recommend encryption for improved security. WEP / WPA-PSK(TKIP) / WPA-PSK(AES) / WPA2-PSK(TKIP) / WPA2-PSK(AES) : Select the encryption method according to the encryption setting of the access point you are using.</p> <p>④ Use Δ ∇ \triangleleft \triangleright to input the "Key" (encryption key) and press ENTER. Enter the same encryption key as used for the access point. The types of characters that can be input are as shown below.</p> <div style="border: 1px solid black; padding: 5px;"> <p>[Lower case characters] abcdefghijklmnopqrstuvwxyz [Upper case characters] ABCDEFGHIJKLMNOPQRSTUVWXYZ [Symbols] ! " # \$ % & ' () * + , - . / : ; < = > ? @ [\] ^ _ ` { } ~ [Numbers] 0123456789 (Space)</p> </div> <p> You can change the character type when you press SEARCH on the main remote control unit or MENU during character input.</p> <ul style="list-style-type: none"> • When no security settings have been used in the Internet connection settings, this step is not necessary. <p>⑤ When encryption is by "WEP", select the "Default Key" using ∇, and then press \triangleleft \triangleright. 1 / 2 / 3 / 4 : Select the same default key as used for the access point. This should normally be set to "1".</p>

See overleaf 

Main remote control unit operation buttons



:Displaying the menu
Cancel the menu



:Moves the cursor
(Up/Down/Left/Right)





:Confirm the setting



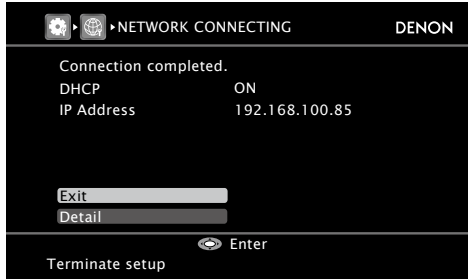
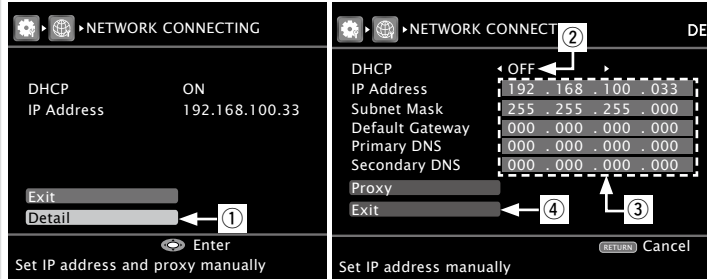

:Return to previous menu



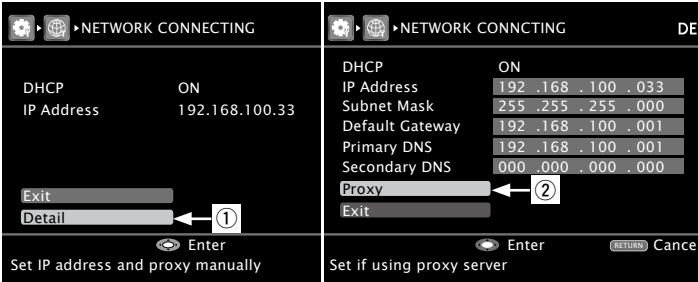
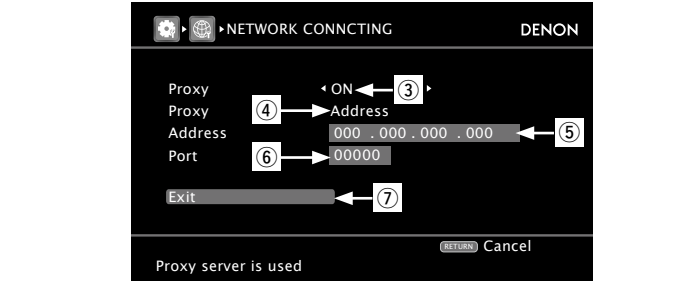

Making Detailed Settings (Manual Setup)

Setting items	Setting contents
Network Connecting (Continued)	<p>⑥ Use ▾ to select "Connection" and press ENTER. Network connection starts. When connection is established with the access point, "Connection completed." is displayed.</p>  <p>AVR-4810 performs automatic network setup due to the DHCP function. When connecting to a network without a DHCP function, you will need to manually configure the IP address. For details, see page 48 "Wired LAN settings" in step 3.</p> <div style="border: 1px solid black; padding: 5px; text-align: center;">Wired LAN settings</div> <p>Use this procedure to configure the Wired LAN settings.</p> <ol style="list-style-type: none"> 1. Connect the LAN cable (☞ page 25 "Connecting to a Home Network (LAN)"). 2. Turn on the AVR-4810 (☞ page 27 "Turning the Power On"). AVR-4810 performs automatic network setup due to the DHCP function. When connecting to a network that has no DHCP function, perform the setting in step 3. 3. Set the IP address at the "Network Connecting". 

Setting items	Setting contents
Network Connecting (Continued)	<ol style="list-style-type: none"> ① On the GUI menu, select "Network Connecting" – "Detail" and press ENTER. ② Use ◀▶ to set "DHCP" to "OFF", then press ▾. The DHCP function is disabled. ③ Use ▲▽▶ to input the address and press ENTER. <ul style="list-style-type: none"> • IP Address : Set the IP address within the ranges shown below. The Network Audio function cannot be used if other IP addresses are set. CLASS A: 10.0.0.0 ~ 10.255.255.255 CLASS B: 172.16.0.0 ~ 172.31.255.255 CLASS C: 192.168.0.0 ~ 192.168.255.255 • Subnet Mask : When connecting an xDSL modem or terminal adapter directly to the AVR-4810, input the subnet mask indicated in the documentation supplied by your provider. Normally input 255.255.255.0. • Default Gateway : When connected to a gateway (router), input its IP address. • Primary DNS, Secondary DNS : If there is only one DNS address indicated in the documentation supplied by your provider, input it at "Primary DNS". If there are two or more DNS addresses, input the first one at "Secondary DNS". ④ Use ▾ to select "Exit" and press ENTER. Setup is complete. <p>※ When connecting to the network via a Proxy server, select "Proxy" and press ENTER (☞ page 49 "Proxy settings").</p>  <ul style="list-style-type: none"> • If you are using a broadband router (DHCP function), there is no need to make the settings at "IP Address" and "Proxy", since the DHCP function is set to "ON" in the AVR-4810's default settings. • If the AVR-4810 is being used connected to a network without the DHCP function, the network settings must be made. In this case, some knowledge of networks is required. For details, consult a network administrator. • If you cannot connect to the Internet, recheck the connections and settings (☞ page 25). • If you do not understand about Internet connection, contact your ISP (Internet Service Provider) or the store from which you purchased your computer. • When you want to cancel the setting during IP address input, press RETURN.





Setting items	Setting contents
Network Connecting (Continued)	<p>Proxy settings : Make this setting when connecting to the Internet via a proxy server.</p>   <ol style="list-style-type: none"> On the GUI menu, select “Network Connecting” – “Detail” or “Manual” and press ENTER. Use $\Delta \nabla$ to set “Proxy” and press ENTER. Use $\triangleleft \triangleright$ to set “Proxy” to “ON” and press ∇. The proxy server is enabled. Use $\triangleleft \triangleright$ to select the proxy server input method, and then press ∇. Address : Select when inputting by address. Name : Select when inputting by domain name. Use $\Delta \nabla \triangleleft \triangleright$ to input the proxy server address or domain name and press ENTER. When “Address” is selected in step ④ : Input the address When “Name” is selected in step ④ : Input the domain name The types of characters that can be input are as shown below. <div style="border: 1px solid black; padding: 5px; margin: 10px 0;"> <p>[Lower case characters] abcdefghijklmnopqrstuvwxyz [Upper case characters] ABCDEFGHIJKLMNOPQRSTUVWXYZ [Symbols] ! " # \$ % & ' () * + , - . / : ; < = > ? @ [\] ^ _ ` { } ~ [Numbers] 0123456789 (Space)</p> </div> <p> You can change the character type when you press SEARCH on the main remote control unit or MENU during character input.</p>

Setting items	Setting contents
Network Connecting (Continued)	<ol style="list-style-type: none"> Use $\Delta \nabla \triangleleft \triangleright$ to input the proxy server port number and press ENTER. Use ∇ to select “Exit” and press ENTER. Setup is complete.
Other Network function on/off setting during standby, and PC language setting.	<p>Network Standby : Set the network function on/off during standby.</p> <ul style="list-style-type: none"> • ON : Network is on during standby. Main unit operable with a network-compatible controller. • OFF : Suspend network function during standby. <p> Set to “ON” when using the web control function (page 94).</p> <p>Character : When characters are not displayed correctly, set the MP3 ID3-Tag character code type reproduced by the USB memory device.</p> <ul style="list-style-type: none"> • Auto : Auto-select character code. • Latin : Select ISO 8859-1 Latin-1. • Japanese : Select Shift-JIS. <p> If the characters are not properly displayed when set to “Auto”, set to “Latin” or “Japanese”.</p> <p>PC Language : Select computer environment language.</p> <ul style="list-style-type: none"> • ara / chi (smp) / chi (trad) / cze / dan / dut / eng / fin / fre / ger / gre / heb / hun / ita / jpn / kor / nor / pol / por / por(BR) / rus / spa / swe / tur <p>Friendly Name Edit : The Friendly Name is the name AVR-4810 displayed on the network. Up to 63 characters can be input. The default Friendly Name on first use is “DENON:[AVR-4810]”.</p> <p>The types of characters that can be input are as shown below.</p> <div style="border: 1px solid black; padding: 5px; margin: 10px 0;"> <p>[Lower case characters] abcdefghijklmnopqrstuvwxyz [Upper case characters] ABCDEFGHIJKLMNOPQRSTUVWXYZ [Symbols] ! " # \$ % & ' () * + , - . / : ; < = > ? @ [\] ^ _ ` { } ~ [Numbers] 0123456789 (Space)</p> </div> <p> You can change the character type when you press SEARCH on the main remote control unit or MENU during character input.</p> <p>Default : Reset all settings to factory default.</p> <ul style="list-style-type: none"> • Yes : Reset to the defaults. • No : Do not reset to the defaults. <p>Party Mode Function : Set the Party Mode function.</p> <ul style="list-style-type: none"> • OFF : Disable Party Mode function. • ON : Enable Party Mode function. <p> Refer to page 92, “Playing the Same Network Audio on Different Devices Connected in a Network (Party Mode Function)” for more information on the party mode function.</p>

Getting Started | Connections | Settings | Playback | Multi-zone | Remote Control | Information | Troubleshooting | Specifications

See overleaf 

Main remote control unit operation buttons









 :Displaying the menu
 :Cancel the menu



 :Moves the cursor
 (Up/Down/Left/Right)

 :Confirm the setting

 :Return to previous menu

Making Detailed Settings (Manual Setup)

Setting items	Setting contents
Other (Continued)	<p>Party Start Level : Make settings for volume level when the Party Mode is started.</p> <ul style="list-style-type: none"> • Last : The same volume as set before the party mode was started. • --- (0) : Always use the muting on condition when the Party Mode is started. • -80dB ~ 18dB (1 ~ 99) : Start party mode with your preferred volume. <p> This can be set when "Party Mode Function" is set to "ON".</p> <ul style="list-style-type: none"> • This is displayed from 0 to 99 when "Volume Display" ( page 52) is set to "Absolute". • You can set to the upper limit set with "Volume Limit" ( page 52) . <p>Network Status : Displays up to a maximum of 10 DENON products connected on the same network.</p> <ul style="list-style-type: none"> • Friendly Name / Model Name / Power ON/Standby / Select Source / Volume Level / Party Mode status <p> "Network Status" is only displayed for DENON products supporting the Network Status function.</p> <p>Update Notification : Displays a notification message on the AVR-4810's GUI screen when the latest firmware is released with "Firmware Update". The notification message is displayed for about 20 seconds when the power is turned on. Connect to broadband Internet ( page 25) when using this function.</p> <ul style="list-style-type: none"> • ON : Display update message. • OFF : Do not display update message. <p> When you press ENTER during display of the notification message, the "Check for Update" screen is displayed. (Refer to page 55 for more information on "Firmware Update".)</p> <ul style="list-style-type: none"> • Press RETURN to erase the notification message. <p>Upgrade Notification : Display a notification message on the AVR-4810's GUI screen when downloadable firmware is released with "Add New Feature". The notification message is displayed for about 20 seconds when the power is turned on. Connect to broadband Internet ( page 25) when using this function.</p> <ul style="list-style-type: none"> • ON : Display upgrade message. • OFF : Do not display upgrade message. <p> When you press ENTER during display of the notification message, the "Add New Feature" screen is displayed. (Refer to page 55 for more information on "Add New Feature".)</p> <ul style="list-style-type: none"> • Press RETURN to erase the notification message.

Setting items	Setting contents
Napster Account Set or change Username and Password ( page 75 "Listening to Napster").	<p>Username / Password The types of characters that can be input are as shown below.</p> <div style="border: 1px solid black; padding: 5px;"> <p>[Lower case characters] abcdefghijklmnopqrstuvwxyz [Upper case characters] ABCDEFGHIJKLMNOPQRSTUVWXYZ [Symbols] ! " # \$ % & ' () * + , - . / : ; < = > ? @ [\] ^ _ ` { } ~ [Numbers] 0123456789 (Space)</p> </div> <p> You can change the character type when you press SEARCH on the main remote control unit or MENU during character input.</p> <ul style="list-style-type: none"> • The password may not contain underscores (_).
Network Information Display network information.	<p>Friendly Name / Network=Wired/Wireless / SSID / DHCP= ON/OFF / IP Address / MAC Address</p>





Making the Multi-zone Settings (Zone Setup)



Default settings are underlined.

Set the audio to playback with multi-zone (ZONE2, ZONE3).

Setting items	Setting contents
Bass Adjust low frequency range (bass).	-10dB ~ +10dB (0dB)
Treble Adjust high frequency range (treble).	-10dB ~ +10dB (0dB)
HPF Make settings for cutting the low range to reduce distortion in the bass.	OFF : The low range is not attenuated. ON : The low range is attenuated.
Lch Level Adjust the left channel output level.	-12dB ~ +12dB (0dB) The "Lch Level" can be set when "Channel" (page 51) is set to "Stereo".
Rch Level Adjust the right channel output level.	-12dB ~ +12dB (0dB) The "Rch Level" can be set when "Channel" (page 51) is set to "Stereo".
Channel Set the signal output from multi-zone.	Stereo : Select stereo output. Mono : Select mono output. When "Amp Assign" - "Assign Mode" (page 40) is set to "FREE", and the signal assigned to the power amp is set to "Z2/Z3(M)", the "Channel" setting automatically becomes "Mono".
Volume Display Set how volume is displayed.	Relative : Display -- dB (Min), in the range -80 dB ~ 18 dB. Absolute : Display in the range 0 (Min) ~ 99. The "Volume Display" setting is applied also to the "Volume Level", "Volume Limit" and "Power On Level" display method. The "Volume Display" setting applies to all zones.

Setting items	Setting contents
Volume Level Set the volume output level.	Variable : Volume adjustment enabled by main unit and remote control unit. -40dB (41) : Fix volume at -40 dB. Set when adjusting volume by external amplifier. 0dB (81) : Fix volume at 0 dB. Set when adjusting volume by external amplifier. When "Amp Assign" - "Assign Mode" (page 40) is set to "+Z2", "+Z2+Z3", "ALL Z2" or "ALL Z2+Z3", the "Volume Level" setting is automatically set to "Variable".
Volume Limit Make a setting for maximum volume.	OFF : Do not set a maximum volume. -20dB (61) / -10dB (71) / 0dB (81) Can be set when the multi-zone "Volume Level" setting (page 51) is "Variable".
Power On Level Define the volume setting that is active when the power is turned on.	Last : Use the memorized setting from the last session. --- (0) : Always use the muting on condition when power is turned on. -80dB ~ 18dB (1 ~ 99) : The volume is adjusted to the set level. Can be set when the multi-zone "Volume Level" setting (page 51) is "Variable".
Mute Level Set the amount of attenuation when muting is on.	Full : The sound is muted entirely. -40dB : The sound is attenuated by 40 dB down. -20dB : The sound is attenuated by 20 dB down.



Making Detailed Settings (Manual Setup)



Making Other Settings (Option Setup)



Default settings are underlined.

Setting items	Setting contents
Volume Control Set the MAIN ZONE volume setting.	Volume Display : Set how volume is displayed. <ul style="list-style-type: none"> • Relative : Display --dB (Min), in the range -80 dB ~ 18 dB. • Absolute : Display in the range 0 (Min) ~ 99. <ul style="list-style-type: none"> • The "Volume Display" setting is applied also to the "Volume Limit" and "Power On Level" display method. • The "Volume Display" setting applies to all zones. <hr/> Volume Limit : Make a setting for maximum volume <ul style="list-style-type: none"> • OFF : Do not set a maximum volume. • -20dB (61) / -10dB (71) / 0dB (81) <hr/> Power On Level : Define the volume setting that is active when the power is turned on. <ul style="list-style-type: none"> • Last : Use the memorized setting from the last session. • -- (0) : Always use the muting on condition when power is turned on. • -80dB ~ 18dB (1 ~ 99) : The volume is adjusted to the set level. <hr/> Mute Level : Set the amount of attenuation when muting is on. <ul style="list-style-type: none"> • Full : The sound is muted entirely. • -40dB : The sound is attenuated by 40 dB down. • -20dB : The sound is attenuated by 20 dB down.
Source Delete Remove input sources that are not used from the display.	PHONO / CD / DVD / HDP / TV / SAT/CBL / VCR / DVR / V.AUX / NET/USB / TUNER : Select input source that is not used. <ul style="list-style-type: none"> • ON : Use this source. • Delete : Do not use this source. <div style="border: 1px solid black; border-radius: 5px; padding: 2px; width: fit-content; margin: 5px 0;">NOTE</div> <ul style="list-style-type: none"> • Input sources being used in the various zones cannot be deleted. • Input sources set to "Delete" cannot be selected using SOURCE SELECT.
GUI Make GUI related settings.	Screensaver : Make screensaver settings. <ul style="list-style-type: none"> • ON : The screen saver is activated during GUI menu display or NET/USB / iPod / TUNER screen display if no operation is performed approximately for a continuous 3-minute period. When you press $\Delta \nabla \triangleleft \triangleright$, the screen saver is cancelled and the screen before that screen saver started is displayed. • OFF : Screen saver is not activated.

Setting items	Setting contents
GUI (Continued)	Wall Paper : Set wallpaper to display the background when playback is stopped, etc. <ul style="list-style-type: none"> • Picture : Set the background to a picture (DENON logo). • Black : Set the background to black. • Gray : Set the background to gray. • Blue : Set the background to blue. <hr/> Format : Set the video signal format to be output for the TV you are using. <ul style="list-style-type: none"> • NTSC : Select NTSC output. • PAL : Select PAL output. The "Format" can also be set by the following procedure. However, the GUI screen is not displayed. <ol style="list-style-type: none"> 1. Press and hold the main unit's DSX and RETURN for at least 3 seconds. "Video Format" appears on the display. 2. Press $\triangleleft \triangleright$ and set the video signal format. 3. Press the main unit's ENTER, MENU or RETURN to complete the setting. <div style="border: 1px solid black; border-radius: 5px; padding: 2px; width: fit-content; margin: 5px 0;">NOTE</div> When a format other than the video format of the connected TV is set, the picture will not be displayed properly. <hr/> Text : Display the content of operation during switching of surround mode, input mode, etc. <ul style="list-style-type: none"> • ON : Turn display on. • OFF : Turn display off. <hr/> Master Volume : Master volume display during adjustment. <ul style="list-style-type: none"> • Bottom : Display at the bottom. • Top : Display at the top. • OFF : Turn display off. When the master volume display is hard to see when superimposed on movie subtitles, set to "Top". <hr/> NET/USB : Set the NET/USB screen display time when the input source is "NET/USB". <ul style="list-style-type: none"> • Always : Show display continuously. • 30s : Show display for 30 seconds after operation. • 10s : Show display for 10 seconds after operation. • OFF : Turn display off.





Setting items	Setting contents
GUI (Continued)	<p>iPod : Set the iPod screen display time when the input source is "iPod".</p> <ul style="list-style-type: none"> • Always : Show display continuously. • 30s : Show display for 30 seconds after operation. • 10s : Show display for 10 seconds after operation. • OFF : Turn display off. <p>Tuner : Set the tuner screen display time when the input source is "TUNER".</p> <ul style="list-style-type: none"> • Always : Show display continuously. • 30s : Show display for 30 seconds after operation. • 10s : Show display for 10 seconds after operation. • OFF : Turn display off.

Remote Preset Codes
Search a preset code to register in the remote control unit.

When preset codes are registered in the included main remote control unit, it can then be used to operate any devices you have, such as DVD players or TVs made by different manufacturers. In this menu, you can search and display the preset codes that can be preset in the included main remote control unit.

□ **Default settings for preset codes**

	DVD Player DENON [32134]
	Video Cassette Recorder Tivo [20739]
	Television SONY [10810]
	Satellite Set Top Box DirecTV [01377]

□ **How to search for preset codes**

Operate with the main remote control unit switched to the "MAIN" mode (page 99 "Operating the Main Remote Control Unit").

1. On the GUI menu, select "Remote Preset Codes" and press **ENTER** or **▷**.
2. Pressing **△▽**, select the category of device for preset registration. Then press **ENTER** or **▷**.

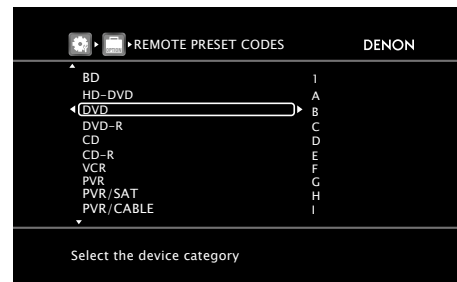

Setting items	Setting contents
Remote Preset Codes (Continued)	<p>3. Pressing △▽, select the first character of the brand name. Then press ENTER or ▷.</p> <p>※ The first character is displayed as 1, A ~ Z. In the case of brand names starting with the @ symbol, select "A". For brand names that start with codes or numbers other than the @ symbol, select "1".</p>

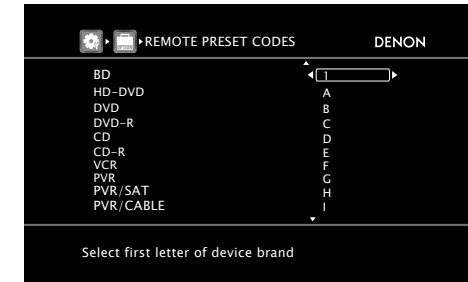

4. Pressing **△▽**, select the brand name. Then press **ENTER** or **▷**.



※ When there are several pages of brand names, the pages can be switched by pressing the main remote control unit's **CH+** or **CH-** when the main remote control unit is in "MAIN" mode.

See overleaf

Main remote control unit operation buttons



SEARCH
:Displaying the menu
Cancel the menu



:Moves the cursor
(Up/Down/Left/Right)









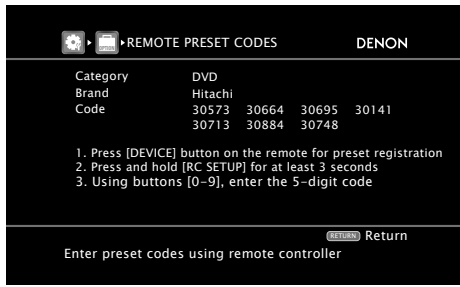

:Confirm the setting





:Return to previous menu



Making Detailed Settings (Manual Setup)

Setting items	Setting contents
Remote Preset Codes (Continued)	<p>5. The procedures for registering remote control codes and remote control preset registration are displayed.</p>  <p>※ When there are several pages of preset codes, the pages can be switched by pressing the main remote control unit's ◀ or ▶ when the main remote control unit is in "MAIN" mode.</p> <p><input type="checkbox"/> How to carry out preset register See page 109 for details on how to carry out preset registration.</p> <ol style="list-style-type: none"> Press DEVICE (DVD/HDP, VCR/DVR, TV or SAT/CABLE) on the main remote control unit for the device you want to preset. Press and hold in RC SETUP on the main remote control unit for at least 3 seconds. The signal transmission indicator flashes twice. Enter a 5-digit code using 0 ~ 9 on the main remote control unit. When the code is registered, the signal transmission indicator flashes twice. Check if the device is operating with the registered preset code. If the device does not operate try registering a different preset code. Press MAIN on the main remote control unit to set the remote control to "MAIN" mode. Press MENU. <p> The main unit can also be operated with MENU, Δ∇◀▶, ENTER.</p>
Quick Select Name Change the "Quick Select" display title to one you prefer.	<ol style="list-style-type: none"> Use Δ∇ to select the name of the Quick Select setting you want to change, then press ▶ or ENTER. Use ◀▶ to set the cursor to the character you want to change. Use Δ∇ to change the character, then press ENTER. <ul style="list-style-type: none"> Up to 16 characters can be input. You can change the character type when you press SEARCH on the main remote control unit or MENU during character input. The types of characters that can be input are as shown below. <div style="border: 1px solid black; padding: 5px; margin-top: 10px;"> <p>[Upper case characters] ABCDEFGHIJKLMNOPQRSTUVWXYZ [Lower case characters] abcdefghijklmnopqrstuvwxyz [Symbols] ! # % & ' () * + , - . / : ; < = " > ? @ [\] [Numbers] 0 1 2 3 4 5 6 7 8 9 (Space)</p> </div>

Setting items	Setting contents
Quick Select Name (Continued)	<ol style="list-style-type: none"> Repeat steps 1 ~ 3 to change the display name.
Zone Rename Change the display title of each zone to one you prefer.	<ol style="list-style-type: none"> Use Δ∇ to select the zone name (MAIN ZONE, ZONE2, ZONE3 or ZONE4) you want to change, then press ▶ or ENTER. Use ◀▶ to set the cursor to the character you want to change. Use Δ∇ to change the character, then press ENTER. <ul style="list-style-type: none"> Up to 10 characters can be input. You can change the character type when you press SEARCH on the main remote control unit or MENU during character input. The types of characters that can be input are as shown below. <div style="border: 1px solid black; padding: 5px; margin-top: 10px;"> <p>[Upper case characters] ABCDEFGHIJKLMNOPQRSTUVWXYZ [Lower case characters] abcdefghijklmnopqrstuvwxyz [Symbols] ! # % & ' () * + , - . / : ; < = " > ? @ [\] [Numbers] 0 1 2 3 4 5 6 7 8 9 (Space)</p> </div> Repeat steps 1 ~ 3 to change the display name.
Trigger Out 1 Select the condition for activating Trigger Out 1 for the input source, surround mode, etc. See "TRIGGER OUT jacks" (page 26) for more information on trigger out.	<p><input type="checkbox"/> When Setting for Zone (MAIN ZONE / ZONE2 / ZONE3 / ZONE4) Trigger out is activated through linkage to the power of the zone set to "ON".</p> <p><input type="checkbox"/> When Setting for Input Source Activate trigger out when the input source set to "ON" is selected.  Valid for the zone set to "ON" with "When Setting for Zone".</p> <p><input type="checkbox"/> When Setting for Surround Mode Activate trigger out when the surround mode set to "ON" is selected.  Valid when the "MAIN ZONE" set to "ON" with "When Setting for Zone" is selected, and when the input source set to "ON" with "When Setting for Input Source" is selected.</p> <p><input type="checkbox"/> When Setting for HDMI Monitor Activate trigger out when the HDMI monitor set to "ON" is selected.  Valid when the "MAIN ZONE" set to "ON" with "When Setting for Zone" is selected, and when the input source set to "ON" with "When Setting for Input Source" is selected.</p> <p><input type="checkbox"/> When setting for "Vertical Stretch" Activate trigger out through linkage when "Vertical Stretch" (page 42) is set to "ON".</p> <p>• ON : Activate trigger on this mode. • --- : Do not activate trigger on this mode.</p>
Trigger Out 2 As with "Trigger Out 1", select the condition for activating Trigger Out 2.	<p><input type="checkbox"/> When Setting for Zone (MAIN ZONE / ZONE2 / ZONE3 / ZONE4) Trigger out is activated through linkage to the power of the zone set to "ON".</p> <p><input type="checkbox"/> When Setting for Input Source Activate trigger out when the input source set to "ON" is selected.  Valid for the zone set to "ON" with "When Setting for Zone".</p> <p><input type="checkbox"/> When Setting for Surround Mode Activate trigger out when the surround mode set to "ON" is selected.  Valid when the "MAIN ZONE" set to "ON" with "When Setting for Zone" is selected, and when the input source set to "ON" with "When Setting for Input Source" is selected.</p> <p><input type="checkbox"/> When Setting for HDMI Monitor Activate trigger out when the HDMI monitor set to "ON" is selected.  Valid when the "MAIN ZONE" set to "ON" with "When Setting for Zone" is selected, and when the input source set to "ON" with "When Setting for Input Source" is selected.</p> <p><input type="checkbox"/> When setting for "Vertical Stretch" Activate trigger out through linkage when "Vertical Stretch" (page 42) is set to "ON".</p> <p>• ON : Activate trigger on this mode. • --- : Do not activate trigger on this mode.</p>



Setting items	Setting contents										
Remote ID Set when you operate another DENON AV amplifier with the remote control unit of the AVR-4810. Match the remote control unit you are using with the remote ID of the AVR-4810.	1 / 2 / 3 / 4  When changing the remote ID, also change the "MAIN", "iPod", "TUNER" and "NET/USB" modes of the main remote control unit at the same time. Also change the sub remote control unit at the same time (☞ page 104, 109 "Setting the Remote ID").										
232C Port Set when using an external controller or two-way remote control unit connected to the RS-232C terminal.	Serial Control : Set when using an external controller. 2Way Remote : Set when using a 2-way remote control unit.  When using a DENON two-way remote control unit (RC-7000CI or RC-7001RCI, sold separately), set to "2Way Remote". NOTE When setting to "2Way Remote", you can not use the RS-232C connector as an external controller.										
Dimmer Adjust display brightness of the receiver.	Bright : Normal display brightness. Dim : Reduced display brightness. Dark : Very low display brightness. OFF : Turns the display off.										
Setup Lock Protect settings from inadvertent change.	OFF : Turn protection off. ON : Turn protection on.  • When "Setup Lock" is set to "ON", the settings listed below can no longer be changed. Also, "SETUP LOCKED!" is displayed if you attempt to operate related settings. <table border="0" style="margin-left: 20px;"> <tr> <td>· GUI menu operations</td> <td>· Dynamic Volume</td> </tr> <tr> <td>· RESTORER</td> <td>· Channel Level</td> </tr> <tr> <td>· Audio/Video Adjust</td> <td>· Audio Delay</td> </tr> <tr> <td>· MultEQ XT</td> <td>· Input Mode</td> </tr> <tr> <td>· Dynamic EQ</td> <td></td> </tr> </table> • When canceling the setting, set "Setup Lock" to "OFF".	· GUI menu operations	· Dynamic Volume	· RESTORER	· Channel Level	· Audio/Video Adjust	· Audio Delay	· MultEQ XT	· Input Mode	· Dynamic EQ	
· GUI menu operations	· Dynamic Volume										
· RESTORER	· Channel Level										
· Audio/Video Adjust	· Audio Delay										
· MultEQ XT	· Input Mode										
· Dynamic EQ											
Maintenance Mode Used when receiving maintenance from a DENON service engineer or custom installer.	NOTE Only use this function if so instructed by a DENON serviceperson or installer.										

Setting items	Setting contents												
Firmware Update Update the firmware of the receiver.	Check for Update : You can check for firmware updates. You can also check approximately how long it will take to complete an update. Start : Execute the update process. When updating starts, the power indicator becomes red and the GUI screen is shut down. The amount of update time which has elapsed is displayed. When updating is complete the power indicator becomes green and normal status is resumed. ※ If updating fails, the set automatically retries, but if updating is still not possible, one of the messages shown below is displayed. If the display reads as shown below, check the settings and network environment, then update again. <table border="1" style="margin-left: 20px;"> <thead> <tr> <th>Display</th> <th>Description</th> </tr> </thead> <tbody> <tr> <td>Updating failed</td> <td>Updating failed.</td> </tr> <tr> <td>Login failed</td> <td>Failure to log into server.</td> </tr> <tr> <td>Server is busy</td> <td>Server is busy. Wait a while then try again.</td> </tr> <tr> <td>Connection fail</td> <td>Failure connecting to server.</td> </tr> <tr> <td>Download fail</td> <td>Downloading of the firmware has failed.</td> </tr> </tbody> </table>	Display	Description	Updating failed	Updating failed.	Login failed	Failure to log into server.	Server is busy	Server is busy. Wait a while then try again.	Connection fail	Failure connecting to server.	Download fail	Downloading of the firmware has failed.
Display	Description												
Updating failed	Updating failed.												
Login failed	Failure to log into server.												
Server is busy	Server is busy. Wait a while then try again.												
Connection fail	Failure connecting to server.												
Download fail	Downloading of the firmware has failed.												
Add New Feature Display new features that can be downloaded to the AVR-4810 and perform an update.	Upgrade : Execute the upgrade process. When updating starts, the power indicator becomes red and the GUI screen is shut down. The amount of update time which has elapsed is displayed. When upgrading is complete the power indicator becomes green and normal status is resumed. ※ If the upgrade is not successful, an error message identical to those in "Firmware Update" will appear on the display, check the settings and network environment, then update again. Upgrade Status : A list of the additional functions provided by the Upgrade will be displayed.  See the DENON website for details about updates. When the procedure is complete, "Registered" is displayed in this menu and updates can be carried out. If the procedure has not been carried out, "Not Registered" is displayed. The ID number shown on this screen is needed when carrying out the procedure. The ID number can also be displayed by pressing and holding  and STATUS on the main unit for at least 3 seconds.												



Making Detailed Settings (Manual Setup)

Notes concerning use of "Firmware Update" and "Add New Feature"

- In order to use these functions, you must have the correct system requirements and settings for a broadband Internet connection (🔗 page 25).
- Do not turn off the power until updating or upgrading is completed.
- Even with a broadband connection to the Internet, approximately 1 hour is required for the updating/upgrading procedure to be completed.
Once updating/upgrade starts, normal operations on the AVR-4810 cannot be performed until updating/upgrading is completed.
Furthermore, updating/upgrading the firmware may reset the backup data for the parameters, etc., set for the AVR-4810.
- The following backup data may be erased after an update or upgrade.
 - Internet radio preset channel
 - Internet radio Recently Played data
 - Care of data in Internet radio, media server and USB memory device
- In the event of an update error during update or upgrade, turn the AVR-4810's power off and then on again. "Update retry" appears on the display and update restarts from the point at which update failed. If the error continues despite this, check the network environment.



- Information regarding the "Firmware Update" function and "Add New Feature" will be announced on the DENON web site each time related plans are defined.
- When usable new firmware is released with "Firmware Update" or "Add New Feature", a notification message is displayed on the GUI screen. When you do not want to be notified, set "Update Notification" (🔗 page 50) and "Upgrade Notification" (🔗 page 50) to "OFF".



Making Language Settings (Language)

GUI

Default settings are underlined>.

Set the language for display on the GUI screen.

Setting contents

English / Deutsch / Français / Italiano / Español / Nederlands / Svenska / 日本語

- The "Language" can also be set by the following procedure. However, the GUI screen is not displayed.

1. Press and hold the main unit's **DSX** and **RETURN** for at least 3 seconds.
"Video Format" appears on the display.
2. Use Δ ∇ to set "GUI Language".
3. Press \triangleleft \triangleright and set the language.
4. Press the main unit's **ENTER**, **MENU** or **RETURN** to complete the setting.



Making the Input Settings (Source Select)

GUI

For details on how to select, set and cancel settings for each menu, see "GUI Menu Operation" (🔗 page 29).

Select input source and make playback settings.

 Items that can be set with the Source Select procedure

Changing the Input Terminal Assignments (Input Assign) 🔗 page 57

Making the Video Settings (Video) 🔗 page 60

Changing the Input Mode and Decoding Mode (Input Mode) 🔗 page 61

Changing the Input Source's Display Name (Rename) 🔗 page 61

Correcting the Input Source's Playback Level (Source Level) 🔗 page 61

Displaying the Playback Screen for the Different Input Sources (Play) 🔗 page 62

Setting the Playback Mode (Playback Mode) 🔗 page 62

- iPod (🔗 page 62)
- NET/USB (🔗 page 62)
- Media Server, USB/iPod and Napster (🔗 page 62)

Making the Settings to Play Still Pictures (Still Picture) 🔗 page 62

Automatically Presetting Radio Stations (Auto Preset) 🔗 page 62

Setting Preset Channels so that They are not Displayed When Tuning (Preset Skip) 🔗 page 63

Giving Names to Preset Stations (Preset Name) 🔗 page 63



Important Information

About the Display of Input Sources in This Manual

In this manual, the names of input sources that can be set at the different items are indicated as shown below.

PHONO CD DVD HDP TV SAT/CBL VCR DVR V.AUX NET/USB Favorites
 Internet Radio Media Server USB/iPod Napster TUNER

NOTE

Input sources that have been set to "Delete" at "Source Delete" (page 52) cannot be selected.

Changing the Input Terminal Assignments (Input Assign)



Default settings are underlined.

Examples of Input Assign Menu Screen Displays

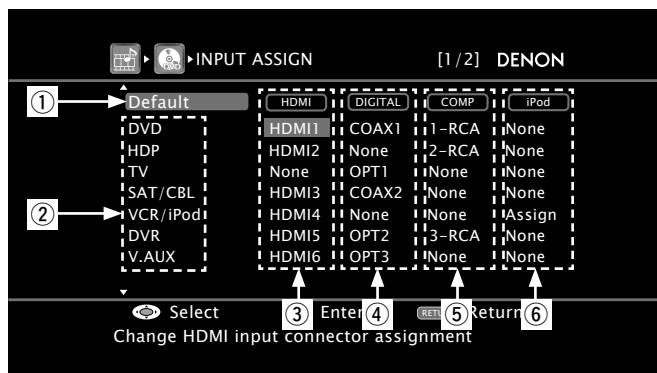

- ① Default button
- ② Input Source
- ③ HDMI input
- ④ Digital audio input
- ⑤ Component video input
- ⑥ iPod dock

Making the Input Settings (Source Select)

Input Assignments Menu Operations

- Press **MENU**.
 The GUI menu is displayed on the TV screen.
 Use $\Delta \nabla$ to select "SOURCE SELECT", then press **ENTER** or \triangleright .

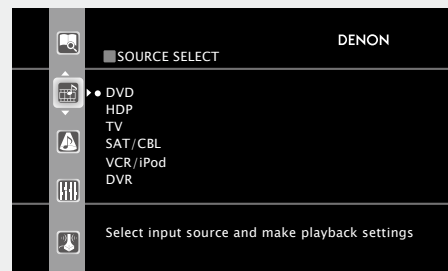

- Press $\Delta \nabla$ to select the input source you want to set, then press \triangleright .



- Select "Input Assign", then press **ENTER** or \triangleright .
 The "INPUT ASSIGN" screen is displayed.

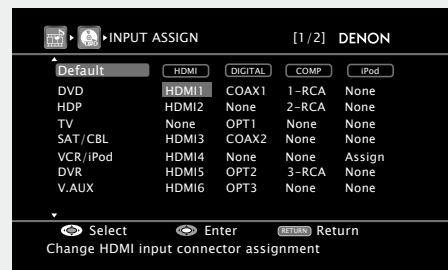

- Use $\Delta \nabla \triangleleft \triangleright$ to move the gray highlight to the item you want to set.

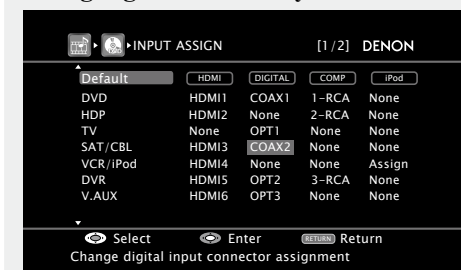

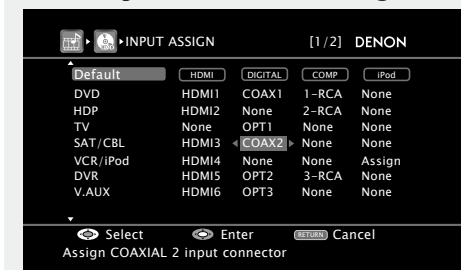

- Press **ENTER**, then use $\triangleleft \triangleright$ to select the input terminal to be assigned.



- Press **ENTER** to enter the setting.



Making the Input Settings (Source Select)

Setting items	Setting contents																
<p>HDMI <input type="checkbox"/> HDMI</p> <p>Set this to change the HDMI input terminals assigned to the input sources.</p>	<p>The <input type="checkbox"/> DVD <input type="checkbox"/> HDP <input type="checkbox"/> TV <input type="checkbox"/> SAT/CBL <input type="checkbox"/> VCR <input type="checkbox"/> DVR <input type="checkbox"/> V.AUX input sources are assigned to the HDMI input terminals as shown below.</p> <p>HDMI 1 / HDMI 2 / HDMI 3 / HDMI 4 / HDMI 5 / HDMI 6 None : Do not assign an HDMI input terminal to the selected input source.</p> <p>※ Upon purchase, the settings of the different input sources are as shown below.</p> <table border="1"> <thead> <tr> <th>Input source</th> <th><input type="checkbox"/> DVD</th> <th><input type="checkbox"/> HDP</th> <th><input type="checkbox"/> TV</th> <th><input type="checkbox"/> SAT/CBL</th> <th><input type="checkbox"/> VCR</th> <th><input type="checkbox"/> DVR</th> <th><input type="checkbox"/> V.AUX</th> </tr> </thead> <tbody> <tr> <td>Default setting</td> <td>HDMI 1</td> <td>HDMI 2</td> <td>None</td> <td>HDMI 3</td> <td>HDMI 4</td> <td>HDMI 5</td> <td>HDMI 6</td> </tr> </tbody> </table> <p> An input source to which an HDMI input terminal cannot be assigned is displayed as “---”.</p> <ul style="list-style-type: none"> To play the video signal assigned at “HDMI” combined with the audio signal assigned at “Input Assign” – “Digital”, select “Digital” at “Input Mode” (page 61). When the AVR-4810 and monitor are connected with an HDMI cable, if the monitor is not compatible with HDMI audio signal playback, only the video signals are output to the monitor. The audio signals input from the analog, digital and EXT. IN connectors are not output to the monitor. When control dock for iPod is used as the input source, assignment of the HDMI input terminal is disabled, even if it is assigned. When “HDMI Control” – “Control” (page 43) is set to “ON”, HDMI input terminal cannot be assigned to “TV”. 	Input source	<input type="checkbox"/> DVD	<input type="checkbox"/> HDP	<input type="checkbox"/> TV	<input type="checkbox"/> SAT/CBL	<input type="checkbox"/> VCR	<input type="checkbox"/> DVR	<input type="checkbox"/> V.AUX	Default setting	HDMI 1	HDMI 2	None	HDMI 3	HDMI 4	HDMI 5	HDMI 6
Input source	<input type="checkbox"/> DVD	<input type="checkbox"/> HDP	<input type="checkbox"/> TV	<input type="checkbox"/> SAT/CBL	<input type="checkbox"/> VCR	<input type="checkbox"/> DVR	<input type="checkbox"/> V.AUX										
Default setting	HDMI 1	HDMI 2	None	HDMI 3	HDMI 4	HDMI 5	HDMI 6										
<p>Digital <input type="checkbox"/> DIGITAL</p> <p>Set this to change the digital input terminals assigned to the input sources.</p>	<p>The <input type="checkbox"/> DVD <input type="checkbox"/> HDP <input type="checkbox"/> TV <input type="checkbox"/> SAT/CBL <input type="checkbox"/> VCR <input type="checkbox"/> DVR <input type="checkbox"/> V.AUX <input type="checkbox"/> CD input sources are assigned to the digital input terminals as shown below.</p> <p>COAX 1 (COAXIAL) / COAX 2 / COAX 3 / OPT 1 (OPTICAL) / OPT 2 / OPT 3 / D.LINK (DENON LINK) *</p> <p>* : “D.LINK” is set when the AVR-4810 is connected by DENON LINK to a DENON Blu-ray disc / DVD player (page 22 “Components Equipped with a DENON LINK Connector”).</p> <p>None : Do not assign a digital input terminal to the selected input source.</p>																

Setting items	Setting contents																				
<p>Digital <input type="checkbox"/> DIGITAL</p> <p>(Continued)</p>	<p>※ Upon purchase, the settings of the different input sources are as shown below.</p> <table border="1"> <thead> <tr> <th>Input source</th> <th><input type="checkbox"/> DVD</th> <th><input type="checkbox"/> HDP</th> <th><input type="checkbox"/> TV</th> <th><input type="checkbox"/> SAT/CBL</th> <th><input type="checkbox"/> VCR</th> </tr> </thead> <tbody> <tr> <td>Default setting</td> <td>COAX 1</td> <td>None</td> <td>OPT 1</td> <td>COAX 2</td> <td>None</td> </tr> </tbody> </table> <table border="1"> <thead> <tr> <th>Input source</th> <th><input type="checkbox"/> DVR</th> <th><input type="checkbox"/> V.AUX</th> <th><input type="checkbox"/> CD</th> </tr> </thead> <tbody> <tr> <td>Default setting</td> <td>OPT 2</td> <td>OPT 3</td> <td>COAX 3</td> </tr> </tbody> </table> <p> When control dock for iPod is used as the input source, assignment of the digital input terminal is disabled, even if it is assigned.</p>	Input source	<input type="checkbox"/> DVD	<input type="checkbox"/> HDP	<input type="checkbox"/> TV	<input type="checkbox"/> SAT/CBL	<input type="checkbox"/> VCR	Default setting	COAX 1	None	OPT 1	COAX 2	None	Input source	<input type="checkbox"/> DVR	<input type="checkbox"/> V.AUX	<input type="checkbox"/> CD	Default setting	OPT 2	OPT 3	COAX 3
Input source	<input type="checkbox"/> DVD	<input type="checkbox"/> HDP	<input type="checkbox"/> TV	<input type="checkbox"/> SAT/CBL	<input type="checkbox"/> VCR																
Default setting	COAX 1	None	OPT 1	COAX 2	None																
Input source	<input type="checkbox"/> DVR	<input type="checkbox"/> V.AUX	<input type="checkbox"/> CD																		
Default setting	OPT 2	OPT 3	COAX 3																		
<p>Component <input type="checkbox"/> COMP</p> <p>Set this to change the component video input terminals assigned to the input sources.</p>	<p>The <input type="checkbox"/> DVD <input type="checkbox"/> HDP <input type="checkbox"/> TV <input type="checkbox"/> SAT/CBL <input type="checkbox"/> VCR <input type="checkbox"/> DVR <input type="checkbox"/> V.AUX input sources are assigned to the component video input terminals as shown below.</p> <p>1-RCA (Component video 1) / 2-RCA (Component video 2) / 3-RCA (Component video 3) None : Do not assign a component video input terminal to the selected input source.</p> <p>※ Upon purchase, the settings of the different input sources are as shown below.</p> <table border="1"> <thead> <tr> <th>Input source</th> <th><input type="checkbox"/> DVD</th> <th><input type="checkbox"/> HDP</th> <th><input type="checkbox"/> TV</th> <th><input type="checkbox"/> SAT/CBL</th> <th><input type="checkbox"/> VCR</th> <th><input type="checkbox"/> DVR</th> <th><input type="checkbox"/> V.AUX</th> </tr> </thead> <tbody> <tr> <td>Default setting</td> <td>1-RCA</td> <td>2-RCA</td> <td>None</td> <td>None</td> <td>None</td> <td>3-RCA</td> <td>None</td> </tr> </tbody> </table> <p> An input source to which a component video input terminal cannot be assigned is displayed as “---”.</p> <ul style="list-style-type: none"> When control dock for iPod is used as the input source, assignment of the component video input terminal is disabled, even if it is assigned. 	Input source	<input type="checkbox"/> DVD	<input type="checkbox"/> HDP	<input type="checkbox"/> TV	<input type="checkbox"/> SAT/CBL	<input type="checkbox"/> VCR	<input type="checkbox"/> DVR	<input type="checkbox"/> V.AUX	Default setting	1-RCA	2-RCA	None	None	None	3-RCA	None				
Input source	<input type="checkbox"/> DVD	<input type="checkbox"/> HDP	<input type="checkbox"/> TV	<input type="checkbox"/> SAT/CBL	<input type="checkbox"/> VCR	<input type="checkbox"/> DVR	<input type="checkbox"/> V.AUX														
Default setting	1-RCA	2-RCA	None	None	None	3-RCA	None														



Making the Input Settings (Source Select)

Setting items	Setting contents
<p>iPod dock <input type="checkbox"/> iPod</p> <p>Assign the control dock for iPod input.</p>	<p>The control dock for iPod can be assigned to the <input type="checkbox"/> DVD <input type="checkbox"/> HDP <input type="checkbox"/> TV <input type="checkbox"/> SAT/CBL <input type="checkbox"/> VCR <input type="checkbox"/> DVR <input type="checkbox"/> V.AUX <input type="checkbox"/> CD input sources.</p> <p>Assign : Assign the control dock for iPod to the selected input source. None : Do not assign the control dock for iPod to the selected input source.</p> <p></p> <ul style="list-style-type: none"> • By default on first use, it is assigned to “VCR (iPod)”. • If control dock for iPod is not connected to the AVR-4810, assignment of the “iPod dock” is disabled, and you can use it as a standard input source.
<p>Default</p> <p>Reset all settings to factory default.</p>	<p>Yes : Reset to the defaults. No : Do not reset to the defaults.</p> <p></p> <p>If you select “Default” and press ENTER the message “Return all settings to the default?” is displayed. Select “Yes” or “No”, and then press ENTER.</p>

Getting Started
Connections
Settings
Playback
Multi-zone
Remote Control
Information
Troubleshooting
Specifications



Making the Input Settings (Source Select)

Making the Video Settings (Video)



Default settings are underlined.

Setting items	Setting contents
<p>Video Select Change video input to your preferred input source.</p>	<p>SOURCE : Play the picture and sound of the input source. DVD / HDP / TV / SAT/CBL / VCR / DVR / V.AUX : Select video input source to view. This can be set for individual input sources.</p> <p> Set by either pressing VIDEO SELECT on the main unit or VIDEO SELECT on the main remote control unit.</p> <ul style="list-style-type: none"> When operating from the main remote control unit Press VIDEO SELECT on the main remote control unit repeatedly until the picture you want to see is displayed. To cancel, press VIDEO SELECT on the main remote control unit, and select "SOURCE". When operating from the main unit After pressing VIDEO SELECT on the main unit, turn the SOURCE SELECT on the main unit until the picture you want to see is displayed. To cancel, press VIDEO SELECT on the main unit, then turn SOURCE SELECT on the main unit and select "SOURCE". <p>NOTE</p> <ul style="list-style-type: none"> It is not possible to select HDMI input signals. The video select function does not work with HDMI signals. Input sources for which "Delete" is selected at "Source Delete" (page 52) cannot be selected.
<p>Video Convert The input video signal is converted automatically in function of the connected TV (page 10 "Converting Input Video Signals for Output (Video Conversion Function)").</p>	<p>This can be set when the input source is DVD HDP TV SAT/CBL VCR DVR V.AUX.</p> <p>ON : The input video signal is converted. OFF : The input video signal is not converted.</p> <p></p> <ul style="list-style-type: none"> When a non-standard video signal from a game machine or some other source is input, the video conversion function might not operate. In this case set "Video Convert" to "OFF". When "Video Convert" is set to "OFF", the video conversion function does not work. In this case, connect the AVR-4810 and TV with the same type of cable.

Setting items	Setting contents
<p>i/p Scaler The input source's resolution is converted to the resolution set at "Resolution".</p>	<p>Analog : Use i/p scaler function for analog video signal. Analog & HDMI : Use i/p scaler function for analog and HDMI video signal. OFF : Do not use i/p scaler function.</p> <p></p> <ul style="list-style-type: none"> This can be set when "Video Convert" is set to "ON". "Analog & HDMI" can be set for input sources for which an HDMI input terminal is assigned. This function is not effective when the input signal is x.v.Color or computer resolution.
<p>Resolution Set resolution of the video signal output to HDMI.</p>	<p>Auto : The number of pixels the TV connected to the HDMI output terminal supports is detected automatically and the appropriate output resolution is set. 480p/576p / 1080i / 720p / 1080p / 1080p:24Hz : Set the output resolution.</p> <p></p> <ul style="list-style-type: none"> This can be set when "i/p Scaler" is set to anything other than "OFF". When "i/p Scaler" is set to "Analog & HDMI", the resolution of both the analog video input signal and HDMI input signal can be set. To watch 1080p/24Hz pictures, use a TV that supports 1080p/24Hz video signals. When set to "1080p/24Hz", you can enjoy film-like pictures for film sources (in 24 Hz). For video sources and mixed sources, we recommend setting the resolution to "1080p". It is not possible to convert a 50 Hz signal into 1080p/24Hz. It is output at a resolution of 1080p/50Hz.
<p>Progressive Mode Select optimum progressive mode for video material.</p>	<p>This can be set when the input source is DVD HDP TV SAT/CBL VCR DVR V.AUX.</p> <p>Auto : The video material is automatically detected and the appropriate mode is set. Video 1 : Select mode suitable for video playback Video 2 : Select mode suitable for video and 30-frame film material playback.</p> <p> This can be set when "i/p Scaler" is set to anything other than "OFF".</p>
<p>Aspect Set the aspect ratio for the video signals output to the HDMI.</p>	<p>This can be set when the input source is DVD HDP TV SAT/CBL VCR DVR V.AUX NET/USB.</p> <p>Full : Output at 16:9 aspect ratio. Normal : Output at 4:3 aspect ratio.</p> <p> This can be set when "i/p Scaler" is set to anything other than "OFF".</p>



Changing the Input Mode and Decoding Mode (Input Mode)



Default settings are underlined.

The selectable input modes depend on the input source and "Input Assign" (page 57) setting.

Setting items	Setting contents
Input Mode Set the audio input modes for the different input sources.	<p>Auto : Automatically detect input signal and perform playback.</p> <p>HDMI : Play only signals from HDMI input.</p> <p>Digital : Play only signals from digital input.</p> <p>Analog : Play only signals from analog input.</p> <p>EXT. IN : Play only signals from EXT. IN input.</p> <p></p> <ul style="list-style-type: none"> "HDMI" can be set for input sources for which "HDMI" is assigned at "Input Assign" (page 58). "Digital" can be set for input sources for which "Digital" is assigned at "Input Assign" (page 58). When digital signals are properly input, the "DIG." indicator lights on the display. If the "DIG." indicator does not light, check the digital input connector assignment and the connections. The surround mode cannot be set if the input mode is set to "EXT. IN".
Decode Mode Set the decode mode for input source	<p>This can be set when the input source is CD DVD HDP TV SAT/CBL VCR DVR V.AUX.</p> <p>Auto : Detect type of digital input signal and decode and play automatically.</p> <p>PCM : Decode and play only PCM input signals.</p> <p>DTS : Decode and play only DTS input signals.</p> <p></p> <ul style="list-style-type: none"> This can be set for input sources for which "HDMI" or "Digital" is assigned at "Input Assign" (page 58). Normally set this to "Auto". Set "PCM" and "DTS" when inputting the corresponding input signal.

Changing the Input Source's Display Name (Rename)



Setting items	Setting contents
Rename Change the display name of the selected input source.	<ol style="list-style-type: none"> Press ▷ or ENTER. Use ◀▷ to set the cursor to the character you want to change. Use △▽ to change the character, then press ENTER. <ul style="list-style-type: none"> Up to 8 characters can be input. The input character type can be switched by pressing SEARCH on the main remote control unit or MENU while the display name is being changed. The types of characters that can be input are as shown below. <div style="border: 1px solid black; padding: 5px; margin: 5px 0;"> <p>[Upper case characters] ABCDEFGHIJKLMNOPQRSTUVWXYZ [Lower case characters] abcdefghijklmnopqrstuvwxyz [Symbols] ! # % & ' () * + , - . / : ; < = " > ? @ [\] [Numbers] 0 1 2 3 4 5 6 7 8 9 (Space)</p> </div> Repeat steps 2 and 3 to change the display name.
Default Reset all settings to factory default.	<p>Yes : Reset to the defaults.</p> <p>No : Do not reset to the defaults.</p>

Correcting the Input Source's Playback Level (Source Level)



Default settings are underlined.

- Corrects the playback level of the selected input source's audio input.
- Set this if there are differences in the input volume levels between the different sources.

Setting contents

<p>-12dB ~ +12dB (0dB)</p> <p></p> <ul style="list-style-type: none"> The analog input level and digital input level can be adjusted independently for input sources for which "HDMI" or "Digital" is assigned at "Input Assign" (page 58). When the input source is "Internet Radio Media Server Napster USB/iPod Favorites", the setting is NET/USB.



Making the Input Settings (Source Select)

Displaying the Playback Screen for the Different Input Sources (Play) **GUI**

When the input source is "**NET/USB** (**Favorites**) **Internet Radio** **Media Server** **USB/iPod** **Napster** **TUNER** (**iPod**)", the corresponding screen can be displayed.

Setting the iPod with iPod Dock Playback Mode (Playback Mode) **GUI**

This can be set for the input source for which "iPod dock" is assigned at "Input Assign" (page 59).

Setting items	Setting contents
Repeat Make settings for repeat mode.	All : Repeat all songs. One : Repeat the current song. OFF : Cancel repeat mode.
Shuffle Make settings for shuffle mode.	Songs : Shuffle all songs. Albums : Shuffle songs from current album only. OFF : Cancel shuffle mode.

Setting the NET/USB Playback Mode (Playback Mode) **GUI**

Default settings are underlined.

This can be set when the input source is **NET/USB**.

Setting items	Setting contents
USB Select Set the USB port to be used.	Front : Select front-panel port. Rear : Select rear-panel port.
Direct Play Use DIRECT PLAY on the sub remote control unit to set the folder to be played.	Favorites : Play songs registered as "Favorites". All Music : Play the songs saved on the PC media.

Setting the Media Server, USB/iPod and Napster Playback Mode (Playback Mode) **GUI**

This can be set when the input source is **Media Server** **USB/iPod** **Napster**.

Setting items	Setting contents
Repeat Make settings for repeat mode.	All : Repeat all files. One : Repeat the current file. OFF : Cancel repeat mode.
Random Make random mode settings.	ON : Enable random playback. OFF : Disable random playback.

Making the Settings to Play Still Pictures (Still Picture) **GUI**

Default settings are underlined.

This can be set when the input source is **NET/USB**.

Setting items	Setting contents
Slide Show Make slide show settings.	ON : Display still picture images in a slide show. OFF : Display only the selected still picture image.
Interval Set the playback time per image.	5s ~ 60s

Automatically Presetting Radio Stations (Auto Preset) **GUI**

Setting items	Setting contents
Start Start the auto preset process.	This can be set when the input source is TUNER .  If an FM station cannot be preset automatically, select the desired station by tuning it in manually, then preset it manually.



Setting Preset Channels so that They are not Displayed When Tuning (Preset Skip) GUI

Default settings are underlined>.

Setting items	Setting contents
<p>A ~ G Set the preset channels that you do not want to display.</p>	<p>This can be set when the input source is TUNER.</p> <p>All : All the preset channels in the selected memory block are skipped.</p> <p>1 ~ 8 : Set the preset channels you do not want to displayed.</p> <ul style="list-style-type: none"> • ON : Display the selected preset channel. • Skip : Do not display the selected preset channel. <p> When set to "All" to "Skip", it is possible to skip entire preset memory blocks (A to G).</p>

Giving Names to Preset Stations (Preset Name) GUI

Setting items	Setting contents
<p>A1 ~ G8 Select the preset channel.</p>	<p>This can be set when the input source is TUNER.</p> <ol style="list-style-type: none"> 1. Press ▷ or ENTER. 2. Use ◀ ▷ to set the cursor to the character you want to change. 3. Use △ ▽ to change the character, then press ENTER. <ul style="list-style-type: none"> • Up to 8 characters can be input. • The input character type can be switched by pressing SEARCH on the main remote control unit or MENU while the display name is being changed. • The types of characters that can be input are as shown below. <div style="border: 1px solid black; padding: 5px; margin: 5px 0;"> <p>[Upper case characters] ABCDEFGHIJKLMNOPQRSTUVWXYZ</p> <p>[Lower case characters] abcdefghijklmnopqrstuvwxyz</p> <p>[Symbols] ! # % & ' () * + , - . / : ; < = " > ? @ [\] (Space)</p> <p>[Numbers] 0123456789</p> </div> 4. Repeat steps 2 and 3 to change the display name.
<p>Default Reset all settings to factory default.</p>	<p>Yes : Reset to the defaults.</p> <p>No : Do not reset to the defaults.</p>



Playback

Symbols used to indicate buttons in this manual

- Button located on both the main unit and the remote control unit → **BUTTON**
- Button only on the main unit → **<BUTTON>**
- Button only on the remote control unit → **[BUTTON]**

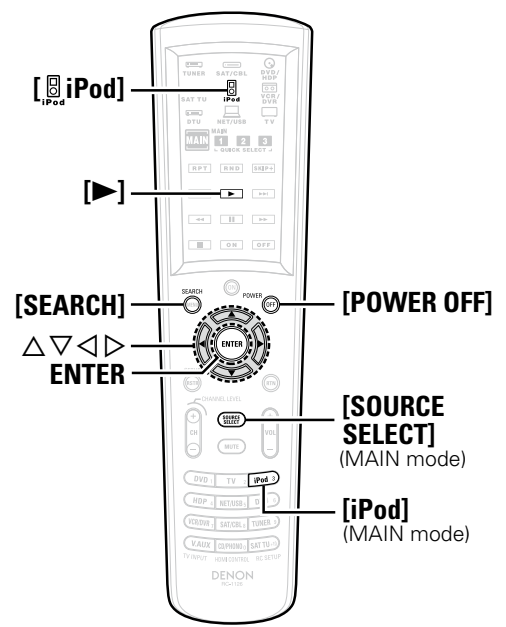
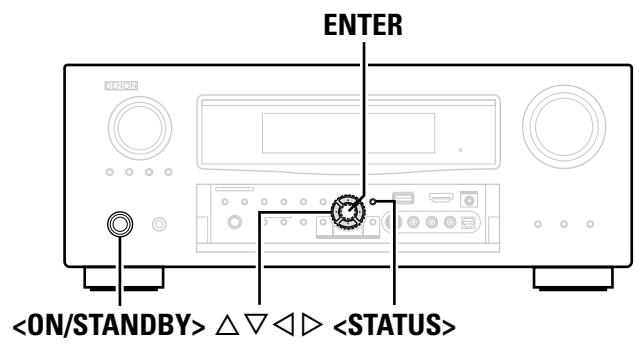

Important Information

Before starting playback, make the connections between the different components and the settings on the receiver.

NOTE

- Also refer to the operating instructions of the connected components when playing them.
- External devices can be controlled by remote control unit (☞ page 99 “Operating the Connected Devices by Remote Control Unit”).

Playing Components

Playing a Blu-ray Disc Player/DVD Player

- The following describes the procedure for playing Blu-ray disc player / DVD player. Use the same procedure to play other components.
- Switch the main remote control unit to the “MAIN” mode when performing this operation (☞ page 99 “Operating the Main Remote Control Unit”).

1 Playback preparation.

- ① Turn on the power of the TV, subwoofer and player.
- ② Switch the TV’s input to the AVR-4810.
- ③ Load the disc in the player.

2 Turn the AVR-4810 power on.

(☞ page 27 “Turning the Power On”)

3 Press [SOURCE SELECT] and select the input source.

Display the source select menu (☞ page 30).

4 Play the component connected to the AVR-4810.

Make the necessary settings on the player (language setting, subtitles setting, etc.) beforehand.

5 Adjust the items below.

- Adjusting the master volume (☞ page 76)
- Selecting the surround mode (☞ page 78)
- Adjusting the Sound and Picture Quality (☞ page 81)

Playing an iPod® Using a Control Dock for iPod

When a DENON control dock for iPod (ASD-1R or ASD-11R, sold separately) is used, you can play images and music stored on an iPod®.

Listening to music on an iPod®

1 Playback preparation.

- ① Connecting the DENON control dock for iPod to the AVR-4810 (☞ page 19 “Control Dock for iPod”).
- ② Set the iPod® in the DENON control dock for iPod.

2 Turn the AVR-4810 power on.

(☞ page 27 “Turning the Power On”)

3 Press [SOURCE SELECT] to display the GUI Source Select menu, then select “iPod” (☞ page 30).

The input source switches to the source to which the control dock for iPod is assigned and the iPod menu is displayed.

– GUI screen –

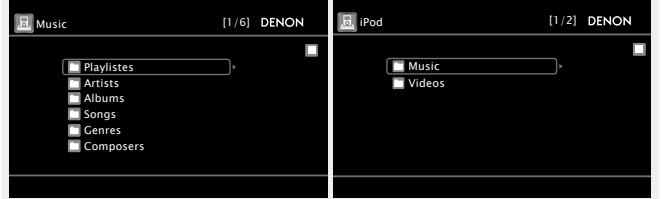

(When using an ASD-1R)

(When using an ASD-11R)

- ※ When using an ASD-11R, the “Music” and “Videos” folders are displayed on the top menu.
- ※ Once communications between the AVR-4810 and the iPod are completed, the connections screen is displayed on the iPod.
- ※ If the connections screen is not displayed, the iPod may not be properly connected. Reconnect it.

4 Set the main remote control unit to the “iPod” mode (☞ page 99 “Operating the Main Remote Control Unit”).

5 Press [SEARCH] and hold it down for a 2 seconds or more to select the display mode.

※ There are two modes for display the contents recorded on the iPod.

Browse mode

This is the mode for displaying the iPod information on the GUI screen to operate the iPod. In this mode, you cannot perform operations directly on the iPod itself.

* With the AVR-4810's display, only English letters and numbers and certain symbols can be displayed. Any characters that cannot be displayed are replaced with "." (period)".

Remote mode

This is the mode for performing operations directly on the iPod itself while watching the screen displayed on the iPod. In this mode, the GUI screen is not displayed.

* "Remote iPod" is displayed on the AVR-4810's display.

Display mode		Browse mode	Remote mode
Playable files	Audio file	○	○
	Picture file	×	○*2
	Movie file	○*1	○*2
Active buttons	Main remote control unit (AVR-4810)	○	○
	iPod®	×	○

*1 : When using an ASD-11R DENON control dock for iPod.

*2 : Video may not be output, depending on the combination of ASD-1R or ASD-11R DENON control dock for iPod and iPod.

6 Use Δ ∇ to select the item, then press ENTER or \triangleright to select the file to be played.

7 Press ENTER, \triangleright or \blacktriangleright . Playback starts.

8 Adjust the items below.

- Adjusting the master volume** (🔧 page 76)
- Selecting the surround mode** (🔧 page 78)
- Adjusting the Sound and Picture Quality** (🔧 page 81)

To stop (🔧 page 76)

Stopping playback temporarily (🔧 page 76)

Fast-forwarding or fast-reversing (🔧 page 76)

To cue to the beginning of a track (🔧 page 76)

Playing repeatedly (🔧 page 77)

Shuffling playback (🔧 page 77)

Searching pages (🔧 page 77)



- Use the RESTORER mode to expand the low and high frequency components of compressed audio files and achieve a richer sound (🔧 page 85). The default setting is "Mode 3".
- The title name, artist name and album name can be checked by pressing <STATUS> during playback.
- The time (default : 30 sec) for which the GUI menus are displayed can be set at "GUI" - "iPod" (🔧 page 53). Press Δ ∇ \triangleleft \triangleright to return to the original screen.
- Press [POWER OFF] or <ON/STANDBY> and set the AVR-4810's power to the standby mode before disconnecting the iPod. Also switch the input source to one to which the menu "iPod" is not assigned before disconnecting the iPod.

NOTE

- Depending on the type of iPod and the software version, some functions may not operate.
- DENON will accept no responsibility whatsoever for any loss of iPod data.

Viewing Videos on an iPod® in the Browse Mode

When an iPod equipped with a video function is connected to a DENON ASD-11R control dock for iPod, video files can be played in the browse mode.

1 Use Δ ∇ to select "Videos", then press ENTER or \triangleright .

2 Use Δ ∇ to select the search item or folder, then press ENTER or \triangleright .

3 Use Δ ∇ to select the video file, then press ENTER or \triangleright .
Playback starts.

Viewing Still Pictures and Videos on an iPod® in the Remote Mode

Photos and videos on an iPod® equipped with a slide show or video function can be played using a DENON ASD-1R or ASD-11R control dock for iPod.

1 Press and hold [SEARCH] to set the Remote mode.
"Remote iPod" is displayed on the AVR-4810's display.

2 Watching the iPod's screen, use Δ ∇ to select "Photos" or "Videos".

※ Depending on the iPod model, it may be necessary to operate the iPod unit directly.

3 Press ENTER until the image you want to view is displayed.



"TV Out" at the iPod's "Slide show Settings" or "Video Settings" must be set to "On" in order to display the iPod's photo data or videos on the monitor. For details, see the iPod's operating instructions.

NOTE

Video may not be output, depending on the combination of ASD-1R or ASD-11R DENON control dock for iPod and iPod.

Playing Components

Symbols used to indicate buttons in this manual

- Button located on both the main unit and the remote control unit → **BUTTON**
- Button only on the main unit → **<BUTTON>**
- Button only on the remote control unit → **[BUTTON]**

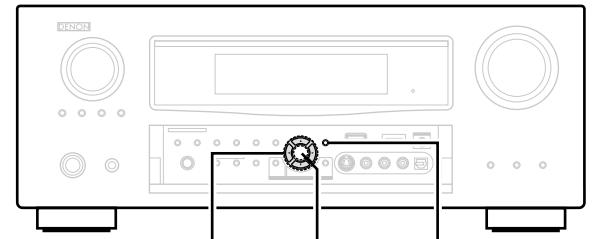

△▽◀▶ **ENTER <STATUS>**

[NET/USB]

[SEARCH]

△▽◀▶ **ENTER**

[SOURCE SELECT] (MAIN mode)

[iPod] (MAIN mode)

[TUNER]

[SHIFT]

Sub remote control unit

[TUNER]

[A ~ G]

[TU ▼]

[TU ▲]

[MEMO]

[MODE]

[BAND]

△▽◀▶ **ENTER**

[SOURCE SELECT] (MAIN mode)

[CHANNEL]

[TUNER] (MAIN mode)

[1 ~ 8]

Playing an iPod® Connected Directly to the AVR-4810's USB Port

- Music stored on an iPod can be played on the AVR-4810 when the AVR-4810 and iPod are connected by USB cable.
- The AVR-4810 supports iPod (5th generation and later), iPod nano, iPod classic, and iPod touch audio (it is not compatible with iPod shuffle). However, some functions may be limited on certain models.
- The operation may not work properly if the iPod's software is old. Be sure to use the latest version of iPod software.
- With iPods, non-copyrighted material and material for which duplication and playback is authorized by law can be duplicated and played by individuals for their personal enjoyment. Infringement of copyrights is prohibited by law.
- Note that DENON will accept no responsibility whatsoever for any problems arising with the data on an iPod when using the AVR-4810 in conjunction with the iPod.

Listening to music on an iPod®

- 1 Connect the iPod® to the AVR-4810's USB port using the USB cable included with the iPod (☞ page 23 "USB Port").**
- 2 Turn the AVR-4810 power on.** (☞ page 27 "Turning the Power On")
- 3 Press [SOURCE SELECT] to display the GUI Source Select menu, then select "[USB]" (☞ page 30).**



- ※ When the iPod is connected directly to the USB port, menus under "Music" are displayed.
- ※ If the screens above are not displayed, the iPod may not be properly connected. Try connecting again.
- ※ When no control dock for iPod is connected, this can also be selected by pressing **[iPod]**.

※ When no control dock for iPod is connected, this operation is also possible in the "iPod" mode.

4 Set the main remote control unit to the "NET/USB" mode (☞ page 99 "Operating the Main Remote Control Unit").

※ When no control dock for iPod is connected, this operation is also possible in the "iPod" mode.

5 Press [SEARCH] and hold it down for a 2 seconds or more to select the display mode.

※ There are two modes for display the contents recorded on the iPod.

Browse mode

This is the mode for displaying the iPod information on the GUI screen to operate the iPod. In this mode, you cannot perform operations directly on the iPod itself.

- ※ With the AVR-4810's display, only English letters and numbers and certain symbols can be displayed. Any characters that cannot be displayed are replaced with ". (period)".

Remote mode

This is the mode for performing operations directly on the iPod itself while watching the screen displayed on the iPod. In this mode, the GUI screen is not displayed.

- ※ "Remote iPod" is displayed on the AVR-4810's display.
- ※ The Remote mode is not supported on 5th generation iPods or iPod nanos.

Display mode		Browse mode	Remote mode
Playable files	Audio file	○	○
	Picture file	×	×
	Movie file	×	×*
Active buttons	Main remote control unit (AVR-4810)	○	○
	iPod®	×	○

* : Only the sound is played.

6 Use △▽ to select the item, then press ENTER or ▶ to select the file to be played.

7 Press ENTER or ▶.
Playback starts.

8 Adjust the items below.

- Adjusting the master volume** (👉 page 76)
 - Selecting the surround mode** (👉 page 78)
 - Adjusting the Sound and Picture Quality** (👉 page 81)
- To stop** (👉 page 76)
 - Stopping playback temporarily** (👉 page 76)
 - Fast-forwarding or fast-reversing** (👉 page 76)
 - To cue to the beginning of a track** (👉 page 76)
 - Playing repeatedly** (👉 page 77)
 - Playing in random order** (👉 page 77)
 - Searching pages** (👉 page 77)



- Use the RESTORER mode to expand the low and high frequency components of compressed audio files and achieve a richer sound (👉 page 85). The default setting is "Mode 3".
- The title name, artist name and album name can be checked by pressing <STATUS> during playback.
- The time (default : 30 sec) for which the GUI menus are displayed can be set at "GUI" – "iPod" (👉 page 53). Press $\Delta \nabla \triangleleft \triangleright$ to return to the original screen.

NOTE

- Depending on the type of iPod and the software version, some functions may not operate.
- DENON will accept no responsibility whatsoever for any loss of iPod data.



"Made for iPod" means that an electronic accessory has been designed to connect specifically to iPod and has been certified by the developer to meet Apple performance standards.

Apple is not responsible for the operation of this device or its compliance with safety and regulatory standards.

iPod is a trademark of Apple Inc., registered in the U.S. and other countries.

- ※ The iPod may only be used to copy or play contents that are not copyrighted or contents for which copying or playback is legally permitted for your private use as an individual. Be sure to comply with applicable copyright legislation.

Tuning in Radio Stations**Listening to FM/AM Broadcasts**

- 1** Press [**SOURCE SELECT**] to display the GUI Source Select menu, then select "📻" (👉 page 30).
- 2** Set the main remote control unit to the "TUNER" mode (👉 page 99 "Operating the Main Remote Control Unit").
- 3** Press [**BAND**] to select "FM" or "AM".
- 4** Tune in the desired broadcast station.
 - ① **To tune in automatically (Auto Tuning)**
Press [**MODE**] to select "AUTO", then use [**TU ▲**] or [**TU ▼**] to select the station you want to hear.
 - ② **To tune in manually (Manual Tuning)**
Press [**MODE**] to select "MANUAL", then use [**TU ▲**] or [**TU ▼**].

5 Adjust the items below.

- Adjusting the master volume** (👉 page 76)
- Selecting the surround mode** (👉 page 78)
- Adjusting the Sound and Picture Quality** (👉 page 81)



- If the desired station cannot be tuned in with auto tuning, tune it in manually.
- When tuning in stations manually, press and hold [**TU ▲**] or [**TU ▼**] to change frequencies continuously.
- The time (default : 30 sec) for which the GUI menu is displayed can be set "GUI" – "Tuner" (👉 page 53). Press $\Delta \nabla \triangleleft \triangleright$ to return to the original screen.

Presetting Radio Stations (Preset Memory)

Your favorite broadcast stations can be preset so that you can tune them in easily. Up to 56 stations can be preset.

- 1** Tune in the broadcast station you want to preset.
- 2** Press [**MEMO**].
- 3** Press [**A ~ G**] to select the block in which the channel is to be preset, then press [**CHANNEL**] or [**1 ~ 8**] to select the preset number.
 - ※ The memory block can also be selected by pressing [**SHIFT**] on the sub remote control unit.
- 4** Press [**MEMO**] again to complete the setting.



- To preset other stations, repeat steps 1 to 4.
- Stations can be preset automatically at "Auto Preset" (👉 page 62).

NOTE

Preset stations are erased by overwriting them.

Tuning in Radio Stations – FM/AM Broadcasts

Symbols used to indicate buttons in this manual

- Button located on both the main unit and the remote control unit → **BUTTON**
- Button only on the main unit → **<BUTTON>**
- Button only on the remote control unit → **[BUTTON]**

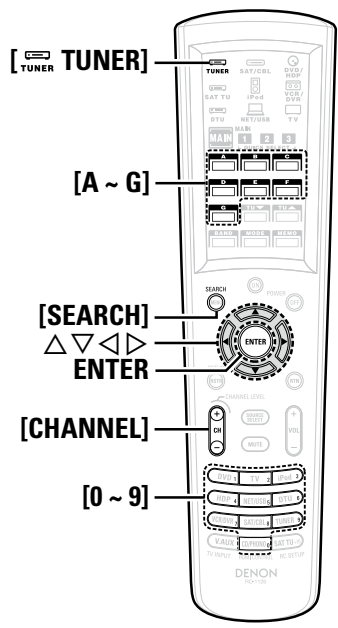
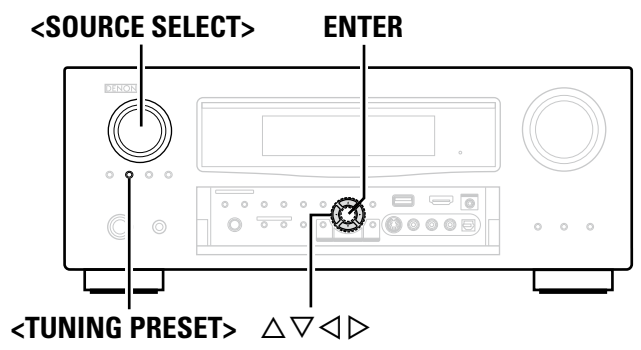

Listening to Preset Stations

- 1 Press **[A ~ G]** to select the memory block (A to G).
- 2 Press **[CHANNEL]** or **[1 ~ 8]** to select the desired preset station.

You can also operate via the main unit. In this case, perform the following operations. Press **<TUNING PRESET>**, then turn **<SOURCE SELECT>** to select the preset radio station.

□ Default settings

Auto tuner presets	
A1 ~ A8	87.5 / 89.1 / 98.1 / 108.0 / 90.1 / 90.1 / 90.1 / 90.1 MHz
B1 ~ B8	522 / 603 / 999 / 1404 / 1611 kHz, 90.1 / 90.1 / 90.1 MHz
C1 ~ C8	90.1 MHz
D1 ~ D8	90.1 MHz
E1 ~ E8	90.1 MHz
F1 ~ F8	90.1 MHz
G1 ~ G8	90.1 MHz

Direct Frequency Tuning

You can enter the receiving frequency directly to tune in.

- 1 Press **[SEARCH]**.
- 2 Input frequencies by means of **[0 ~ 9]**.
※ If **<** is pressed, the immediately preceding input is cancelled.
- 3 When setting is completed, press **ENTER**.
The preset frequency is tuned in.

RDS (Radio Data System)

RDS (works only on the FM band) is a broadcasting service which allows a station to send additional information along with the regular radio program signal. The following three types of RDS information can be received with this unit:

Program Type (PTY)

PTY identifies the type of RDS program. The program types and their displays are as follows:

NEWS	News	WEATHER	Weather
AFFAIRS	Current Affairs	FINANCE	Finance
INFO	Information	CHILDREN	Children's programmes
SPORT	Sports	SOCIAL	Social Affairs
EDUCATE	Education	RELIGION	Religion
DRAMA	Drama	PHONE IN	Phone In
CULTURE	Culture	TRAVEL	Travel
SCIENCE	Science	LEISURE	Leisure
VARIED	Varied	JAZZ	Jazz Music
POP M	Pop Music	COUNTRY	Country Music
ROCK M	Rock Music	NATION M	National Music
EASY M	Easy Listening Music	OLDIES	Oldies Music
LIGHT M	Light Classical	FOLK M	Folk Music
CLASSICS	Serious Classical	DOCUMENT	Documentary
OTHER M	Other Music		

Traffic Program (TP)

TP identifies programs that carry traffic announcements. This allows you to easily find out the latest traffic conditions in your area before leaving home.

Radio Text (RT)

RT allows RDS stations to send text messages that appear on the display.

NOTE

The operations described below using **[SEARCH]** will not function in areas in which there are no RDS broadcasts.

RDS Search

Use this function to automatically tune to FM stations that provide the RDS service.

1 Press **[SEARCH]** twice to select “RDS”.

2 Press **[CHANNEL]**.
The search for RDS stations begins automatically.

- ※ If no RDS stations are found with the above operation, all the reception bands are searched.
- ※ When a broadcast station is found, that station’s name appears on the display.

3 To continue searching, repeat steps 1 to 2.

- ※ If no RDS station is found when all the frequencies have been searched, “NO RDS” is displayed.

PTY Search

Use this function to find RDS stations broadcasting a designated program type (PTY).

For a description of each program type, refer to “Program Type (PTY)”.

1 Press **[SEARCH]** three times to select “PTY”.

2 Watching the display, press Δ ∇ to call out the desired program type.

3 Press **[CHANNEL]**.
PTY search begins automatically.

- ※ If there is no station broadcasting the designated program type with the above operation, all the reception bands are searched.
- ※ The station name is displayed on the display after searching stops.

4 To continue searching, repeat steps 1 to 3.

- ※ If no station broadcasting the designated program type is found when all the frequencies have been searched, “NO PROGRAMME” is displayed.

TP Search

Use this function to find RDS stations broadcasting traffic programs (TP stations).

1 Press **[SEARCH]** four times to select “TP”.

2 Press **[CHANNEL]**.
TP search begins automatically.

- ※ If no TP station is found with the above operation, all the reception bands are searched.
- ※ The station name is displayed on the display after searching stops.

3 To continue searching, repeat steps 1 to 2.

- ※ If no other TP station is found when all the frequencies have been searched, “NO PROGRAMME” is displayed.

RT (Radio Text)

“RT” appears on the display when radio text data is received.

Press **[SEARCH]** five times to select “RT”.

- ※ While receiving an RDS broadcast station, the text data broadcast from the station is displayed.
- ※ To turn the display off, press \triangleleft \triangleright .
- ※ If no text data is being broadcast, “NO TEXT DATA” is displayed.

Playing Network Audio, USB Memory Devices

This procedure can be used to play Internet radio stations or music or still picture (JPEG) files stored on a computer or USB memory device.

Important Information

About the Internet Radio Function

- Internet radio refers to radio broadcasts distributed over the Internet. Internet radio stations from around the world can be tuned in. The AVR-4810 is equipped with the following Internet radio functions:
 - Stations can be selected by genre and region.
 - Up to 56 Internet radio stations can be preset.
 - Internet radio stations in MP3 and WMA (Windows Media Audio) format can be listened to.
 - Your favorite radio stations can be registered by accessing an exclusive DENON Internet radio URL from a Web browser on a computer.
- ※ The function is managed for individual users, so you must provide your MAC or e-mail address.
Exclusive URL: <http://www.radiodenon.com>
- ※ The radio station database service may be suspended without notice.
- The AVR-4810’s Internet radio station list is created using a radio station database service (vTuner). This database service provides a list edited and created for the AVR-4810.

Playing Network Audio, USB Memory Devices

Media Player

This function lets you play music files and playlists (m3u, wpl) stored on a computer (media server) connected to the AVR-4810 via a network. With the AVR-4810's network audio playback function, connection to the server is possible using one of the technologies below.

- Windows Media Player Network Sharing Service
- Windows Media DRM10

Album Art Function

When a WMA (Windows Media Audio), MP3 or MPEG-4 AAC file includes album art data, the album art can be displayed while the music files are playing.



For music files in WMA (Windows Media Audio) format, the album art is only played when using Windows Media Player ver. 11.

Slide Show Function

Still picture (JPEG) files stored in folders on a media server can be played as slide shows. The time for which each picture is displayed can be set.



The AVR-4810 plays back image (JPEG) files in the orientation in which they are stored in the folder.

USB Memory Devices

A USB memory device can be connected to the AVR-4810's USB port to play music and still picture (JPEG) files stored on the USB memory device.

Also, files stored on an iPod can be played when the iPod is connected directly to the AVR-4810's USB port. See "Playing an iPod® Connected Directly to the AVR-4810's USB Port" (page 66).

- Only USB memory devices conforming to mass storage class and MTP (Media Transfer Protocol) standards can be played on the AVR-4810.
- The AVR-4810 is compatible with USB memory devices in "FAT16" or "FAT32" format.

Album Art Function

When an MP3 music file includes album art data, the album art can be displayed while playing the file.

Slide Show Function

Still picture (JPEG) files stored on USB memory devices can be played as slide shows.

The time for which each picture is displayed can be set.



The AVR-4810 plays back image (JPEG) files in the orientation in which they are stored in the folder.

[Compatible formats]

	Internet radio	Media server* 1	USB memory devices* 1
WMA (Windows Media Audio)	○	○	○* 3
MP3 (MPEG-1 Audio Layer-3)	○	○	○
WAV	–	○	○
MPEG-4 AAC	–	○* 2	○* 2
FLAC (Free Lossless Audio Codec)	–	○	○
JPEG	–	○	○

A server or server software compatible with distribution in the corresponding formats is required to play music files via a network.

- * 1 : Media server and USB
 - The AVR-4810 is compatible with MP3 ID3-Tag (Ver. 2) standards.
 - The AVR-4810 is compatible with WMA META tags.
 - WAV format Quantization bit rate: 16 bits.
- * 2 : Only files that are not protected by copyright can be played on the AVR-4810.

Contents downloaded from pay sites on the Internet are copyright protected. Also, files encoded in WMA format when ripped from a CD, etc., on a computer may be copyright protected, depending on the computer's settings.
- * 3 : Copyright-protected files can be played on certain portable players compatible with MTP.

[Compatible formats]

	Sampling frequency	Bit rate	Extension
WMA (Windows Media Audio)	32/44.1/48kHz	48 ~ 192kbps	.wma
MP3 (MPEG-1 Audio Layer-3)	32/44.1/48kHz	32 ~ 320kbps	.mp3
WAV	32/44.1/48kHz	–	.wav
MPEG-4 AAC	32/44.1/48kHz	16 ~ 320kbps	.aac/ .m4a/ .mp4
FLAC (Free Lossless Audio Codec)	32/44.1/48kHz	–	.flac

About Napster

Napster is a monthly subscription music distribution service provided by Napster. This service allows users to download and play pieces of music they want to hear on the AVR-4810. Before you can use Napster, you will need to visit the Napster website on your PC to create an account and register as a member. For details, access the following site:

http://www.napster.com/choose/index_default.html

Symbols used to indicate buttons in this manual

- Button located on both the main unit and the remote control unit → **BUTTON**
- Button only on the main unit → **<BUTTON>**
- Button only on the remote control unit → **[BUTTON]**

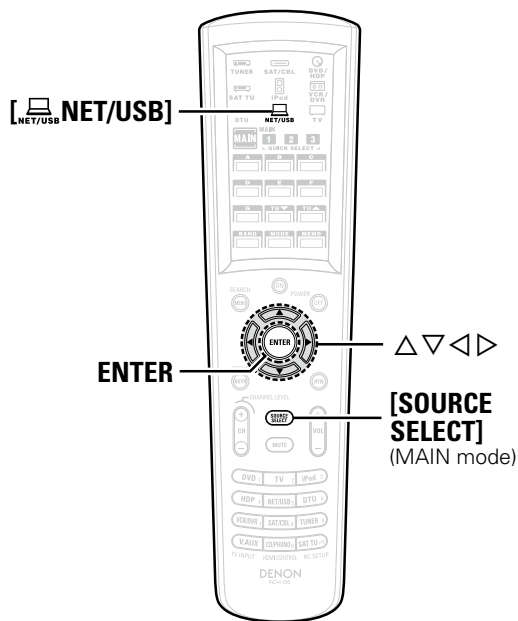
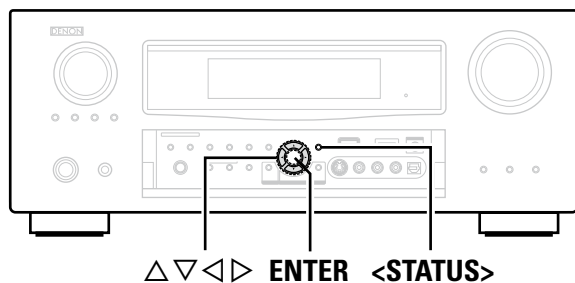

Listening to Internet Radio

1 Playback preparation.

- Check the network environment, then turn on the AVR-4810's power (☞ page 25 "Connecting to a Home Network (LAN)").
- If settings are required, make the "Network Connecting" (☞ page 45).

2 Press [SOURCE SELECT] to display the GUI Source Select menu, then select "🌐" (☞ page 30).

3 Set the main remote control unit to the "NET/USB" mode (☞ page 99 "Operating the Main Remote Control Unit").

4 Press Δ ∇ to select the item you want to play, then press ENTER or \triangleright . The station list is displayed.

5 Press Δ ∇ to select the station, then press ENTER or \triangleright . Playback starts once buffering reaches "100%".

6 Adjust the items below.

- Adjusting the master volume (☞ page 76)
- Selecting the surround mode (☞ page 78)
- Adjusting the Sound and Picture Quality (☞ page 81)

- To stop (☞ page 76)
- Searching pages (☞ page 77)
- Searching by first letter (☞ page 77)



- There are many Internet radio stations on the Internet, and the quality of the programs they broadcast as well as the bit rate of the tracks varies widely. Generally, the higher the bit rate, the higher the sound quality, but depending on the communication lines and server traffic, the music or audio signals being streamed may be interrupted. Inversely, lower bit rates mean a lower sound quality but less tendency for the sound to be interrupted.
- "Server Full" or "Connection Down" is displayed if the station is busy or not broadcasting.
- On the AVR-4810, folder and file names can be displayed as titles. Any characters that cannot be displayed are replaced with ". (period)".
- Use the RESTORER mode to expand the low and high frequency components of compressed audio files and achieve a richer sound "RESTORER" (☞ page 85). The default setting is "Mode 3".
- When <STATUS> is pressed, the display can be switched between the title name and radio station name.
- The time (default : 30 sec) for which the GUI menu are displayed can be set at GUI menu "GUI" – "NET/USB" (☞ page 52). Press Δ ∇ \triangleleft \triangleright to return to the original screen.

Recently Played Internet Radio Stations

Recently played internet radio stations can be selected from "Recently Played".
Up to 20 stations stored in "Recently Played".

1 Press Δ ∇ to select "Recently Played", then press ENTER or \triangleright .

2 Press Δ ∇ to select the item you want to play, then press ENTER or \triangleright .

Playing Network Audio, USB Memory Devices

Symbols used to indicate buttons in this manual

- Button located on both the main unit and the remote control unit → **BUTTON**
- Button only on the main unit → **<BUTTON>**
- Button only on the remote control unit → **[BUTTON]**

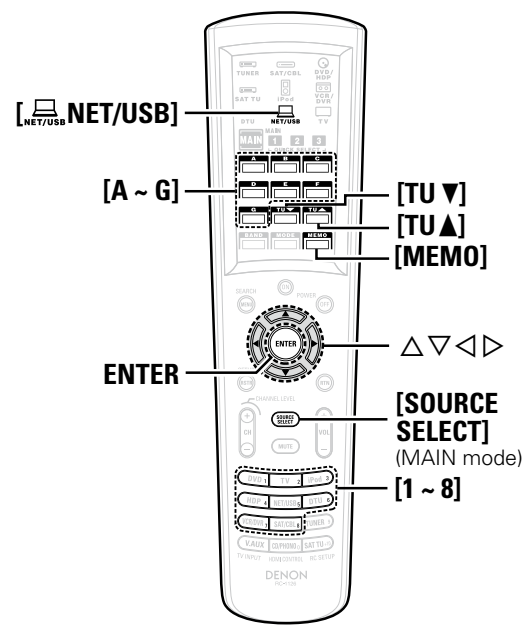
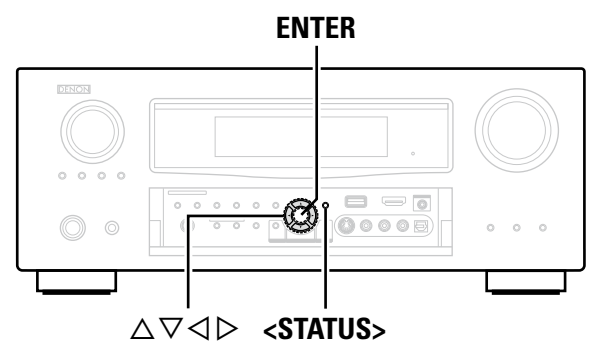

Search Stations by Keyword (Alphabetic Strings)

- 1 Press △▽ to select “Search by Keyword”, then press **ENTER** or ▶.
The search display appear.

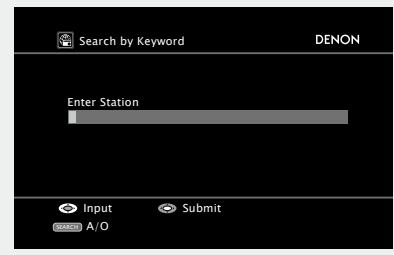

- 2 Enter the characters, then press **ENTER**.

Presetting Internet Radio Stations

Preset Internet radio stations can be selected directly.

- 1 While the Internet radio station you want to preset is playing, press **[MEMO]**.
- 2 Press △▽ to select “Preset”, then press **ENTER**.
- 3 Press [A ~ G], then press [1 ~ 8] to select the desired preset number.
- 4 Press **[MEMO]** again to complete the setting.
The Internet radio station is now preset.

NOTE
If registered at a number that has already been preset, the previously registered setting is cleared.

Listening to Preset Internet Radio Stations

After pressing [A ~ G], press [1 ~ 8] to select the registered preset number.
The AVR-4810 automatically connects to the Internet and playback begins.

Registering Internet Radio Stations as Your Favorites

Favorites are listed at the top of the menu screen, so when a station is registered as a favorite it can be tuned in easily.

- 1 Press **[MEMO]** while the Internet radio station you want to register is playing.
 - 2 Press △▽ to select “Favorites”, then press **ENTER**.
 - 3 Press ◀ to select “Add”.
The Internet radio station is registered.
- ※ If you do not want to register it, press ▶.

Listening to Internet Radio Stations Registered in Your Favorites

- 1 Press **[SOURCE SELECT]** to display the GUI Source Select menu, then select “📶” (👉 page 30).
- 2 Press △▽ to select the Internet radio station, then press **ENTER** or ▶.
The AVR-4810 automatically connects to the Internet and playback begins.

Clearing Internet Radio Stations from Your Favorites

- 1 Press **[SOURCE SELECT]** to display the GUI Source Select menu, then select “📶” (👉 page 30).
 - 2 Press △▽ to select the Internet radio station you want to clear, then press **[MEMO]**.
 - 3 Press ◀ to select “Remove”.
The selected Internet radio station is cleared.
- ※ To cancel the operation without clearing the station, press ▶.

Playing Files Stored on a Computer

Use this procedure to play music files, image files or playlists.

1 Playback preparation.

- ① Check the network environment, then turn on the AVR-4810's power (☞ page 25 "Connecting to a Home Network (LAN)").
- ② If settings are required, make the "Network Connecting" (☞ page 45).
- ③ Prepare the computer (☞ Computer's operating instructions).

2 Press [SOURCE SELECT] to display the GUI Source Select menu, then select "📁" (☞ page 30).

3 Switching the main remote control unit to the "NET/USB" mode (☞ page 99 "Operating the Main Remote Control Unit").

4 Use Δ / ∇ to select the server including the file to be played, then press ENTER or \triangleright .

5 Press Δ / ∇ to select the search item or folder, then press ENTER or \triangleright .

6 Press Δ / ∇ to select the file, then press ENTER or \triangleright . Playback starts once buffering reaches "100%".

7 Adjust the items below.

- Adjusting the master volume** (☞ page 76)
- Selecting the surround mode** (☞ page 78)
- Adjusting the Sound and Picture Quality** (☞ page 81)

To stop (☞ page 76)

Stopping playback temporarily (☞ page 76)

Selecting tracks (☞ page 77)

Playing repeatedly (☞ page 77)

Playing in random order (☞ page 77)

Searching pages (☞ page 77)

Searching by first letter (☞ page 77)



- When playing still picture (JPEG) files, files can also be selected using the operation described below. During playback, either press [TU ▲] (previous file) or [TU ▼] (next file).
- Connections to the required system and specific settings must be made in order to play music files (☞ page 25).
- Before starting, you must launch the computer's server software and set the files as server contents. For details, see the operating instructions of your server software.
- Depending on the size of the still picture (JPEG) file, some time may be required for the file to be displayed.
- The order in which the tracks/files are displayed depends on the server specifications. If due to the server specifications the tracks/files are not displayed in alphabetical order, searching by the first letter may not work properly.
- WMA Lossless files can be played when using a server supporting transcoding, such as Windows Media Player Ver. 11.
- Use the RESTORER mode to expand the low and high frequency components of compressed audio files and achieve a richer sound (☞ page 85). The default setting is "Mode 3".
- The time (default : 30 sec) for which the GUI menus are displayed can be set at "GUI" – "NET/USB" (☞ page 52).
- Use <STATUS> to switch between displaying the title name, artist name or album name.

Playing files that have been Preset or Registered in Your Favorites

Files can be preset, registered in your favorites and played using the same operations as for Internet radio stations (☞ page 72).

NOTE

- Presettings are erased by overwriting them.
- When the operation described below is performed, the media server's database is updated and it may no longer be possible to play preset or favorite music files.
 - When you quit the media server and then restart it.
 - When music files are deleted or added on the media server.

Playing Network Audio, USB Memory Devices

Symbols used to indicate buttons in this manual

- Button located on both the main unit and the remote control unit → **BUTTON**
- Button only on the main unit → **<BUTTON>**
- Button only on the remote control unit → **[BUTTON]**

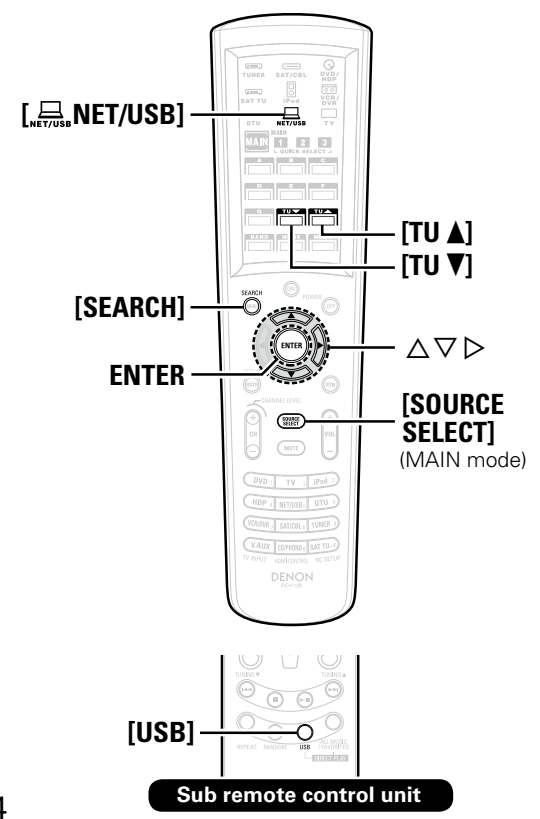
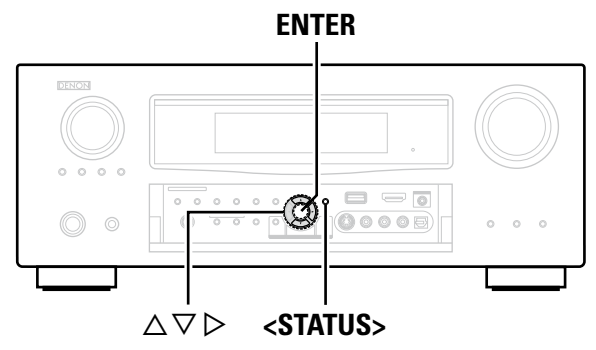

Playing Files Stored on USB Memory Devices

Only USB memory devices conforming to mass storage class and MTP (Media Transfer Protocol) standards can be played on the AVR-4810.

- 1 Playback preparation.**
 - At "USB Select" (☞ page 62), select the USB port to be used.
 - Connect the USB memory device to the USB port set in ①.
- 2 Press [SOURCE SELECT] to display the GUI Source Select menu, then select "USB" (☞ page 30).**
- 3 Set the main remote control unit to the "NET/USB" mode (☞ page 99 "Operating the Main Remote Control Unit").**
- 4 Press ▲▼ to select the search item or folder, then press ENTER or ▷.**
- 5 Press ▲▼ to select the file, then press ENTER or ▷.** Playback starts once buffering reaches "100%".
- 6 Adjust the items below.**
 - Adjusting the master volume** (☞ page 76)
 - Selecting the surround mode** (☞ page 78)
 - Adjusting the Sound and Picture Quality** (☞ page 81)

- To stop** (☞ page 76)
- Stopping playback temporarily** (☞ page 76)
- Selecting tracks** (☞ page 77)
- Playing repeatedly** (☞ page 77)
- Playing in random order** (☞ page 77)
- Searching pages** (☞ page 77)
- Searching by first letter** (☞ page 77)

- By default, the front panel's USB port will be used.
- Depending on the size of the still picture (JPEG) file, some time may be required for the file to be displayed.
- During playback of still picture (JPEG) files, the files can also be switched using **[TU ▲]** (previous file) and **[TU ▼]** (next file).
- If the USB memory device is divided into multiple partitions, only the top partition can be selected.
- The AVR-4810 is compatible with MP3 files conforming to "MPEG-1 Audio Layer-3" standards.
- When **[USB]** on the sub remote control unit is pressed, playback starts from the first file stored on the USB memory device.

NOTE

- The AVR-4810 is equipped with two USB ports, one each on the front and rear panels. It is not possible to use the set with USB memory devices connected to both the ports at the same time. Select the USB port you want to use at "USB Select" (☞ page 62).
- DENON will accept no responsibility whatsoever for any loss or damage to data on USB memory devices when using the USB memory device connected to the AVR-4810.
- USB memory devices will not work via a USB hub.
- DENON does not guarantee that all USB memory devices will operate or receive power. When using a portable USB connection type HDD of the kind to which an AC adapter can be connected to supply power, use the AC adapter.
- It is not possible to connect and use a computer via the AVR-4810's USB port using a USB cable.
- The AVR-4810 is not compatible with the iPod shuffle.

Listening to Napster

1 Playback preparation.

- ① Check the network environment, then turn on the AVR-4810's power (☞ page 25 "Connecting to a Home Network (LAN)").
- ② If settings are required, make the "Network Connecting" (☞ page 45).

2 Press [SOURCE SELECT] to display the GUI Source Select menu, then select "📶" (☞ page 30).

3 Set the main remote control unit to the "NET/USB" mode (☞ page 99 "Operating the Main Remote Control Unit").

4 Use Δ ∇ \triangleright to input "Username" and "Password".

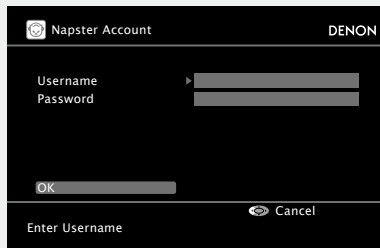

5 After inputting the "Username" and "Password", select "OK", then press ENTER.

If the "Username" and "Password" match, the top menu for Napster is displayed.

☐ Username : _____

[Input characters]

[Lower case characters] abcdefghijklmnopqrstuvwxyz
 [Upper case characters] ABCDEFGHIJKLMNOPQRSTUVWXYZ
 [Symbols] ! " # \$ % & ' () * + , - . / : ; < = > ? @ [\] ^ _ ` { | } ~
 [Numbers] 0123456789 (Space)

☐ Password : _____

[Input characters]

[Lower case characters] abcdefghijklmnopqrstuvwxyz
 [Upper case characters] ABCDEFGHIJKLMNOPQRSTUVWXYZ
 [Symbols] ! " # \$ % & ' () * + , - . / : ; < = > ? @ [\] ^ _ ` { | } ~
 [Numbers] 0123456789 (Space)

6 Adjust the items below.

- ☐ Adjusting the master volume (☞ page 76)
- ☐ Selecting the surround mode (☞ page 78)
- ☐ Adjusting the Sound and Picture Quality (☞ page 81)

Search From Napster Menu

1 Use Δ ∇ to select search item or folder, then press ENTER or \triangleright .

2 Use Δ ∇ to select the track item, then press ENTER or \triangleright .

Enter a Character Search For the Track You Want to Listen to

1 Press [SEARCH].



※ You can search by artist name, album name or track name.

2 Use Δ ∇ to select the search item, then press ENTER. The search display appears.

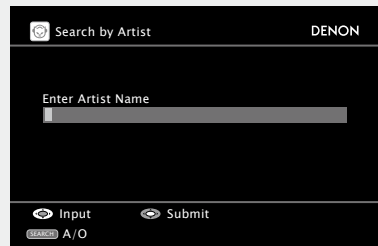

3 Enter the characters, then press ENTER.

Registering Tracks in My Napster Library

1 Press \triangleright while the track you wish to register is playing.

2 Select "Add to my library", then press ENTER or \triangleright . The track is entered in the Library.

☐ Listening to Tracks Registered In My Napster Library

1 Use Δ ∇ to select "My Napster Library", then press ENTER or \triangleright .

2 Use Δ ∇ to select the information or track, then press ENTER.

After selecting, the information is displayed.

☐ To stop (☞ page 76)

☐ Selecting tracks (☞ page 77)

☐ Playing repeatedly (☞ page 77)

☐ Playing in random order (☞ page 77)

☐ Searching pages (☞ page 77)



- Use the RESTORER mode to expand the low and high frequency components of compressed audio files and achieve a richer sound. The default setting is "Mode 3" (☞ page 85).
- The time (default : 30 sec) for which the GUI menus are displayed can be set at "GUI" - "NET/USB" (☞ page 52).
- Use <STATUS> to switch between displaying the title name, artist name or album name.

Symbols used to indicate buttons in this manual

Button located on both the main unit and the remote control unit → **BUTTON**
 Button only on the main unit → **<BUTTON>**
 Button only on the remote control unit → **[BUTTON]**

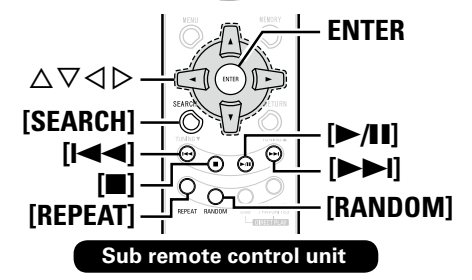
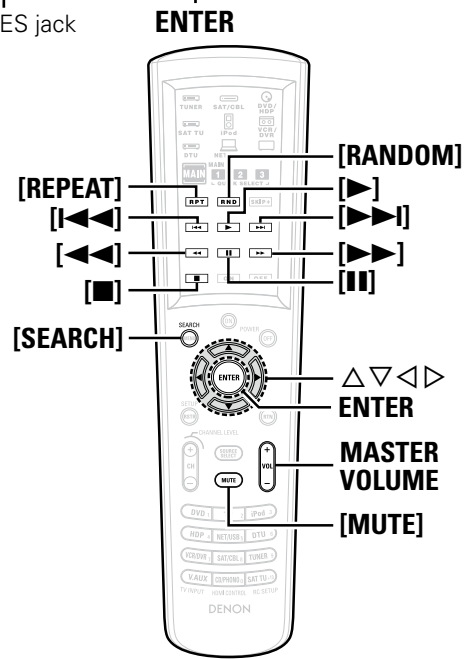
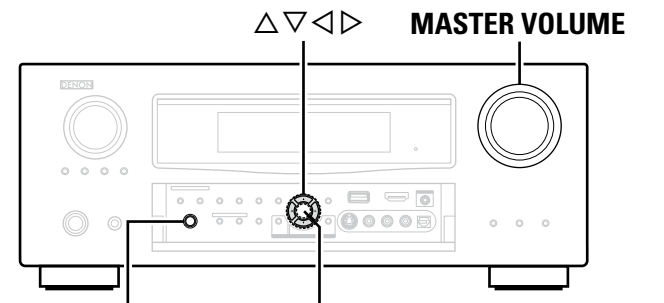

Operations During Playback

Adjusting the Master Volume

Use **MASTER VOLUME** to adjust the volume.

- When the "Volume Display" setting (page 52) is "Relative"
 [Adjustable range] --- -80.5dB ~ 18.0dB
- When the "Volume Display" setting (page 52) is "Absolute"
 [Adjustable range] 0.0 ~ 99.0

* The adjustable range depends on the input signal, the channel level settings, etc.

Turning Off the Sound Temporarily (Muting)

Press **[MUTE]**.

- The sound is reduced to the level set at "Mute Level" (page 52).
- To cancel, press **[MUTE]** again. Muting can also be canceled by adjusting the master volume.

Listening with Headphones

Plug the headphones into the PHONES jack on the main unit.
 The sound from the speakers and pre-out connectors is automatically cut.

- NOTE**
- To prevent hearing loss, do not raise the volume level excessively when using headphones.
 - Remove your headphones when performing Audyssey Auto Setup or adjusting the speaker volume.

To Stop

During playback, either press and hold **ENTER** or press **[■]**.

Stopping Playback Temporarily

During playback, press **ENTER**, **[■]** or **[▶/■]** on the sub remote control unit.
 Press again to resume playback.

Fast-forwarding or Fast-reversing



During playback, press and hold **[◀◀]** (fast-reverse) or **[▶▶]** (fast-forward), or press and hold **△▽**.
 * Control Dock for iPod only.

To Cue to the Beginning of a Track

During playback, either press **[|◀◀]** (to search for previous tracks) or **[▶▶|]** (to search for subsequent tracks), or press **△▽**.

Playing Repeatedly

Press **[REPEAT]**.

GUI menu display	GUI menu display during remote control unit operation	Display	Setting contents
All		ALL	Repeat all songs.
One		One	Repeat the current song.
OFF		OFF	Disable repeat playback.

※ GUI menu "Repeat" ( page 62) can be set in the same way.





The repeat mode applies when playing tracks on the USB memory device and on the media server.

Selecting Tracks

During playback, either press \triangle (previous track) or ∇ (next track).

Shuffling Playback

Press **[RANDOM]**.

GUI menu display	GUI menu display during remote control unit operation	Display	Setting contents
Albums		Albums	Shuffle songs from current album only.
Songs		Songs	Shuffle all songs.
OFF		OFF	Cancel shuffle mode.

※ GUI menu "Shuffle" ( page 62) can be set in the same way.

Playing in Random Order

Press **[RANDOM]**.

GUI menu display	GUI menu display during remote control unit operation	Display	Setting contents
ON		ON	Enable random playback.
OFF		OFF	Disable random playback.

※ GUI menu "Random" ( page 62) can be set in the same way.



The random mode applies when playing tracks on the USB memory device and on the media server.

Searching Pages

Press **[SEARCH]**, then press \triangleleft (previous page) or \triangleright (next page).

※ To cancel, press $\triangle\nabla$ or **[SEARCH]**.

Searching by First Letter

This operation is convenient for choosing items from the menu screens for Internet radio stations or files stored on the computer.

When the menu screen is displayed, press [SEARCH] twice, then press \triangleleft \triangleright to select the first letter you want to search for.

- If there are multiple items starting with the selected letter, they are displayed in alphabetical order.
- If it is not possible to search the list, "unsorted list." is displayed.

※ To cancel, press $\triangle\nabla$ or **[SEARCH]**.



If the list is not in alphabetical order, you may not be able to perform a character search.



Selecting the Surround Mode (Surround Mode)

Symbols used to indicate buttons in this manual

- Button located on both the main unit and the remote control unit → **BUTTON**
- Button only on the main unit → **<BUTTON>**
- Button only on the remote control unit → **[BUTTON]**

① Playing Sources According to the Sources' Audio Signal Format/ Number of Channels (Standard Playback)

Operations

The selectable surround modes depend on the following:

- Format of the audio signals being input
- Number of channels of the audio signals being input
- The set amplifier assignment (☞ page 40)

- 1 **Playing the source** (☞ page 64).
- 2 **Press STANDARD to select the surround mode.**

Surround Playback of 2-channel Sources

① The mode switches as shown below each time **STANDARD** is pressed.

- DOLBY PLIIz** *1 : The signals are decoded in DOLBY PLIIz for playback.
- DOLBY PLIIx** *2 : The signals are decoded in DOLBY PLIIx for playback.
- DOLBY PLII** : The signals are decoded in DOLBY PLII for playback.
- DTS NEO:6** : The signals are decoded in DTS NEO:6 for playback.

*1 : This can be set when "Amp Assign" – "Extra Channel" is set to "FH" and "Speaker Configuration" – "Front Height" is set to something other than "None".

*2 : This can be set when "Amp Assign" – "Extra Channel" is set to "SB" and "Speaker Configuration" – "Surround Back" is set to something other than "None".

② Select the mode for the source at "Mode" (☞ page 81).

- Cinema** : This mode is suited for movie sources.
- Music** : This mode is suited for music sources.
- Game** : This mode is suited for games.
- Pro Logic** : This is the Pro Logic playback mode. This can be selected when playing with a DOLBY PLII decoder.
- Height** : This is the Front Height playback mode. Set "Front Height" to "ON" (☞ page 82).

※ The modes that can be selected depend on the input source being played.

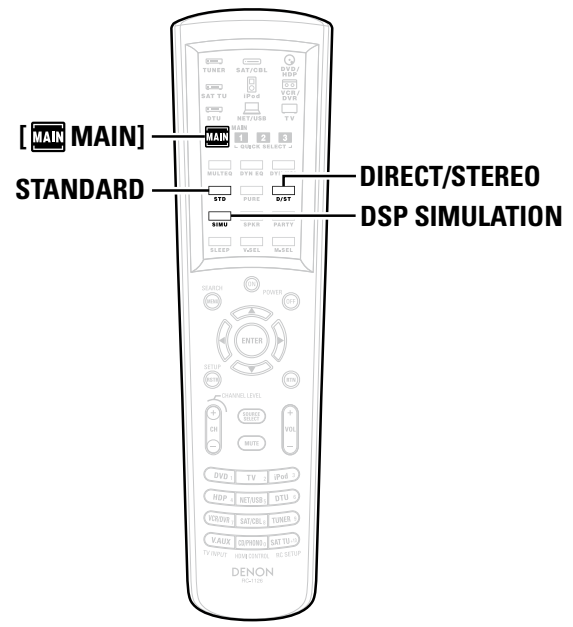
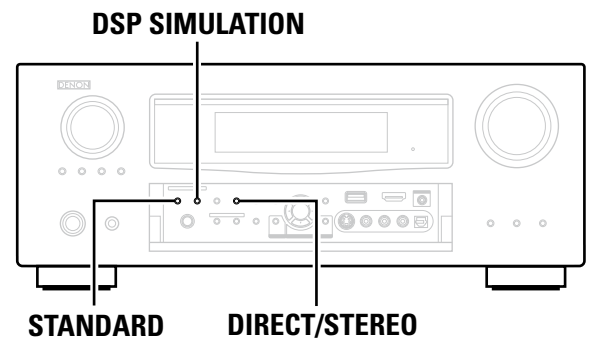

❑ **Surround Playback of Multi-channel Sources (Dolby Digital, DTS, etc.)**

In the case of standard playback of multi channel sources, the AVR-4810 recognizes the format of the multi-channel audio input signal and automatically operates the appropriate decoder for surround sound.

Displaying the Currently Playing Surround Mode

Input signal	The indication contents of the display
DOLBY DIGITAL (other than 2ch) / DOLBY DIGITAL EX	DOLBY DIGITAL
	DOLBY DIGITAL EX
	DOLBY DIGITAL+PLIIx CINEMA
	DOLBY DIGITAL+PLIIx MUSIC
DOLBY DIGITAL Plus	DOLBY DIGITAL+PLIIz
	DOLBY DIGITAL+
	DOLBY DIGITAL+ +EX
	DOLBY DIGITAL+ + PLIIx CINEMA
	DOLBY DIGITAL+ + PLIIx MUSIC
DOLBY TrueHD	DOLBY DIGITAL+ + PLIIz
	DOLBY TrueHD
	DOLBY TrueHD+EX
	DOLBY TrueHD+PLIIx CINEMA
	DOLBY TrueHD+PLIIx MUSIC
DTS (5.1ch) / DTS-ES Discrete 6.1 / DTS-ES Matrix 6.1 / DTS 96/24	DOLBY TrueHD+PLIIz
	DTS SURROUND
	DTS+PLIIx CINEMA
	DTS+PLIIx MUSIC
	DTS+PLIIz
	DTS+NEO:6
	DTS ES MTRX6.1 (*1)
	DTS ES DSCRT6.1 (*2)
	DTS 96/24 (*3)
	DTS-HD HI RES
DTS-HD MSTR	
DTS-HD	DTS-HD+NEO:6
	DTS-HD+PLIIx CINEMA
	DTS-HD+PLIIx MUSIC
	DTS-HD+PLIIz
	DTS EXPRESS
	MULTI CH IN
PCM (multi ch) / DSD (multi ch)	MULTI IN+Dolby EX
	MULTI IN+PLIIx CINEMA
	MULTI IN+PLIIx MUSIC
	MULTI IN+PLIIz
	MULTI CH IN 7.1

*1 : This is displayed when the input signal is "DTS-ES Matrix 6.1" and the AVR-4810's "AFDM" (page 82) setting is set to "ON"

*2 : This is displayed when the input signal is "DTS-ES Discrete 6.1".

*3 : This is displayed when the input signal is "DTS 96/24".

For details, see page 116.

② Playing in a DENON Original Surround Mode

The desired mode according to the program source and viewing situation can be selected from among 10 DENON original surround modes.

1 Playing the source (page 64).

2 Select the surround mode by pressing **DSP SIMULATION**.

MULTI CH STEREO : This mode is for enjoying stereo sound from all speakers.

WIDE SCREEN : This mode is for enjoying the atmosphere of viewing a movie on a large screen.

SUPER STADIUM : This mode is suited for viewing sports programs.

ROCK ARENA : This mode is for enjoying the atmosphere of a live concert in an arena.

JAZZ CLUB : This mode is for enjoying the atmosphere of a live concert in a jazz club.

CLASSIC CONCERT : This mode is for appreciating classical concert programs.

MONO MOVIE * : This mode is for playing monaural movie sources with surround sound.

VIDEO GAME : This mode is suited for achieving surround sound with video games.

MATRIX : This mode lets you add a sense of expansion to stereo music sources.

VIRTUAL : This mode is for enjoying surround effects using only the front speakers or headphones.

* : When playing sources recorded in monaural in the "MONO MOVIE" mode, the sound will be off balance with a single channel (left or right), so input to both channels.

Depending on the program source being played, it may not be possible to achieve a satisfactory surround effect. In this case, try other modes to achieve a sound field suited to your tastes.

③ Direct Playback

In this mode the signals bypass the tone control circuitry for high quality sound. The sound is output to the same channels as the input signal.

1 Playing the source (page 64).

2 Press **DIRECT/STEREO** to select the "DIRECT".

Displaying the Currently Playing Surround Mode

Input signal	The indication contents of the display
Analog signal / PCM (2ch) / Dolby Digital source / DTS source / Other 2-channel digital signals	DIRECT
DSD (2ch)	DSD DIRECT (*)
PCM (multi ch)	MULTI CH DIRECT
	MULTI CH DIRECT + Dolby EX
	MULTI CH DIRECT + PLIIx CINEMA
	MULTI CH DIRECT + PLIIx MUSIC
DSD (multi ch)	MULTI CH DIRECT 7.1
	DSD MULT DIRECT (*)

* : When DSD signals are converted to PCM signals as set by the audio parameters and speaker settings, "DIRECT" or "MULTI CH DIRECT" is displayed.

For details, see page 117.

Selecting the Surround Mode (Surround Mode)

Symbols used to indicate buttons in this manual

- Button located on both the main unit and the remote control unit → **BUTTON**
- Button only on the main unit → **<BUTTON>**
- Button only on the remote control unit → **[BUTTON]**

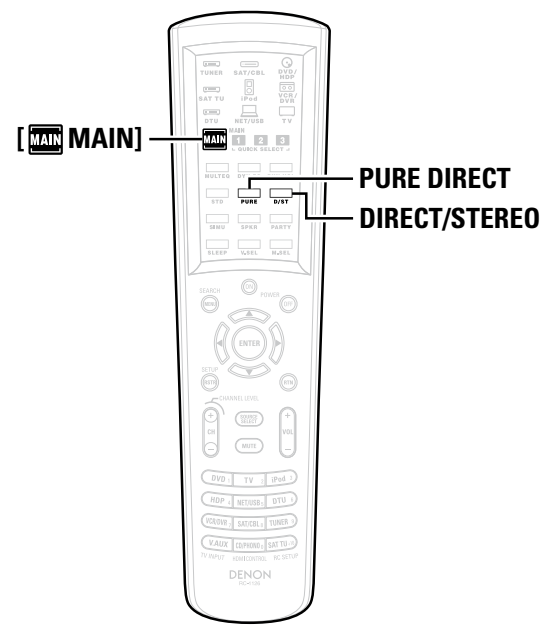
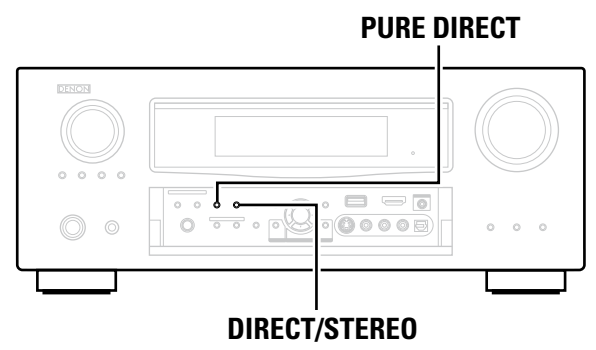

④ Stereo Playback

This is the mode for playing in stereo. The tone can be adjusted. Sound is output from the front left and right speakers and subwoofer.

- 1** Playing the source (page 64).
- 2** Press **DIRECT/STEREO** to select the “STEREO”.

⑤ Playing the Pure Direct Mode

This is the mode that recreates the original sound most faithfully, providing extremely high quality sound.

- 1** Playing the source (page 64).
- 2** Press **PURE DIRECT**.

- To cancel, press **PURE DIRECT** again.
- During playback in PURE DIRECT mode, the surround parameters are the same as in DIRECT mode.
- Video signals are only output when HDMI signals are played in the PURE DIRECT mode.

NOTE

When in the PURE DIRECT mode, the GUI menu display is not displayed and the display on the main unit is turned off.



Adjusting the Sound and Picture Quality (Audio/Video Adjust)

For details on how to select, set and cancel settings for each menu, see "GUI Menu Operation" (page 26).



Adjusting the Sound (Audio Adjust)



Default settings are underlined.

The sound being played in the surround mode can be adjusted to your liking. The items (parameters) that can be adjusted depend on the signal being input and the currently set surround mode. For details on the adjustable parameters, see "Surround Modes and Parameters" (page 114).

Setting items	Setting contents
Surround Parameters Adjust surround sound parameters.	<p>Mode : Set the play modes for the different surround modes.</p> <p><input type="checkbox"/> In the PLIIx or PLII mode</p> <ul style="list-style-type: none"> Cinema : Surround sound mode optimized for movie sources. Music : Surround sound mode optimized for music sources. Game : Surround sound mode optimized for games. Pro Logic : Dolby Pro Logic playback mode (PLII mode only). <p><input type="checkbox"/> In the PLIIz mode</p> <ul style="list-style-type: none"> Height : Dolby PLIIz Height playback mode. <p><input type="checkbox"/> In the DTS NEO:6 mode</p> <ul style="list-style-type: none"> Cinema : Surround sound mode optimized for movie sources. Music : Surround sound mode optimized for music sources. <p> When "Surround Parameters" – "Front Height" (page 82) is set to "ON", the "Height" mode is set automatically.</p> <ul style="list-style-type: none"> The "Music" mode is also effective for movie sources including a lot of stereo music. <p>Cinema EQ : Soften the treble range of movie soundtracks for better understanding.</p> <ul style="list-style-type: none"> OFF : "Cinema EQ" is not used. ON : "Cinema EQ" is used. <p>DRC : Compress dynamic range (difference between loud and soft sounds)</p> <ul style="list-style-type: none"> Auto : Automatic dynamic range compression on/off control according to source. This can be set in the Dolby TrueHD mode. Low / Middle / High : These set the compression level. OFF : Dynamic range compression always off <p>D.COMP : Compress dynamic range (difference between loud and soft sounds).</p> <ul style="list-style-type: none"> OFF : Turn dynamic range compression off. Low / Middle / High : These set the compression level.

Setting items	Setting contents
Surround Parameters (Continued)	<p>LFE : Adjust the low-frequency effects level (LFE).</p> <ul style="list-style-type: none"> -10dB ~ 0dB <p> For proper playback of the different sources, we recommend setting to the values below.</p> <ul style="list-style-type: none"> Dolby Digital sources : "0dB" DTS movie sources : "0dB" DTS music sources : "-10dB" <p>Center Image : Assign center channel signal to front left and right channels for wider sound.</p> <ul style="list-style-type: none"> 0.0 ~ 1.0 (0.3) <p>Panorama : Assign front L/R signal also to surround channels, for wider sound.</p> <ul style="list-style-type: none"> OFF : Do not set. ON : Set. <p>Dimension : Shift sound image center to front or rear, to adjust playback balance.</p> <ul style="list-style-type: none"> 0 ~ 6 (3) <p>Center Width : Assign center channel signal to front left and right channels for wider sound.</p> <ul style="list-style-type: none"> 0 ~ 7 (3) <p>Delay Time : Adjust delay time to control sound stage size.</p> <ul style="list-style-type: none"> 0ms ~ 300ms (30ms) <p>Effect : Switch effect signal for multi-surround speakers on and off.</p> <ul style="list-style-type: none"> ON : Create a wider sound stage. OFF : The effect is not set. <p>Effect Level : Adjust effect signal level.</p> <ul style="list-style-type: none"> 1 ~ 15 (10) <p> Set to a lower level if the positioning and sense of phase of the surround signals seems unnatural.</p> <p>Room Size : Determine size of acoustic environment.</p> <ul style="list-style-type: none"> Small : Simulate acoustics of a small room. Medium small : Simulate acoustics of a medium-small room. Medium : Simulate acoustics of a medium room. Medium large : Simulate acoustics of a medium-large room. Large : Simulate acoustics of a large room <p>NOTE</p> <p>"Room Size" does not indicate the size of the room in which sources are played.</p>

Main remote control unit operation buttons



:Displaying the menu
Cancel the menu



:Moves the cursor
(Up/Down/Left/Right)







:Confirm the setting







:Return to previous menu

Adjusting the Sound and Picture Quality (Audio/Video Adjust)

Setting items	Setting contents
Surround Parameters (Continued)	<p>Front Height : Set the Dolby PLIIz Height mode to ON or OFF.</p> <ul style="list-style-type: none"> • ON : Switch to Dolby PLIIz Height mode. • OFF : Do not switch to Dolby PLIIz Height mode. <p></p> <ul style="list-style-type: none"> • "Front Height" is not displayed with the settings listed below. <ul style="list-style-type: none"> • When "Amp Assign" – "Extra Channel" (page 40) is set to "FH" • When the "Speaker Configuration" – "Front Height" setting (page 41) is set to "None" • When "Surround Mode" (page 78) is set to something other than "STANDARD" • "Front Height" cannot be set if the HD Audio source being played includes a front height channel. In this case, the Front height channel is played back without decoding in PLIIz mode, using the input signal. <p>AFDM (Auto flag detect mode) : Detects the source's surround back channel signal and sets the optimum surround mode automatically.</p> <ul style="list-style-type: none"> • OFF : Do not set. • ON : Set. <p>[Example] Playing Dolby Digital software (with EX flag)</p> <ul style="list-style-type: none"> • When "AFDM" is set to "ON", the surround mode is automatically set to the DOLBY D + PLIIx C mode. • To play in the DOLBY DIGITAL EX mode, set "AFDM" to "OFF" and "Surround Back" to "MTRX ON". <p></p> <ul style="list-style-type: none"> • Some Dolby Digital EX sources do not include EX flags. If the playback mode does not switch automatically even when "AFDM" is set to "ON", set "Surround Back" to "MTRX ON" or "PLIIx CINEMA". • If the setting in "Speaker Configuration" – "Surround Back" (page 40) is "None", "Surround Back" is not displayed. <p>Surround Back : Sets the method of generating of the surround back channel.</p> <p><input type="checkbox"/> For 2-channel sources</p> <ul style="list-style-type: none"> • ON : The surround back channel is used. • OFF : No signal is played from the surround back channels.

Setting items	Setting contents
Surround Parameters (Continued)	<p><input type="checkbox"/> For multi-channel sources</p> <p>Set the decoding method for the surround back channel.</p> <ul style="list-style-type: none"> • DSCRT ON : Play the surround back signals included in the 7.1-channel source. • MTRX ON : Generate and play the surround back signals from the surround channel signals. • ES MTRX*1 : Generate and play the surround back signals from the surround channel signals of the DTS source. • ES DSCRT*2 : Play the surround back signals included in the 6.1-channel DTS source. • PLIIx CINEMA*3 : Generate and play the surround back signals by decoding the signals in the Dolby Pro Logic IIx Cinema mode. • PLIIx MUSIC : Generate and play the surround back signals by decoding the signals in the Dolby Pro Logic IIx Music mode. • OFF : The surround back channel is not played. <ul style="list-style-type: none"> *1 : This can be selected when playing DTS sources. *2 : This can be selected when playing DTS sources including a signal to identify discrete 6.1-channel signals. *3 : This can be selected when "Speaker Configuration" – "Surround Back" (page 40) is set to "2spkr". <p></p> <ul style="list-style-type: none"> • This can also be set by pressing STANDARD on the main remote control unit. • If the source being played contains a surround back signal, the decoder type is automatically selected by the AFDM function. Set "AFDM" to "OFF" to switch to your preferred decoder. • If the setting in "Speaker Configuration" – "Surround Back" (page 40) is "None", "Surround Back" is not displayed. <p>Subwoofer Att. : Attenuate subwoofer level when using EXT. IN input.</p> <ul style="list-style-type: none"> • ON : Set. • OFF : Do not set. Usually use in this mode. <p></p> <p>Set this to "ON" if the subwoofer channel level seems too high when playing audio signal.</p> <p>Subwoofer : Turn subwoofer output on and off.</p> <ul style="list-style-type: none"> • ON : The subwoofer is used. • OFF : The subwoofer is not used. <p>Default : Restores all the surround parameter settings to their defaults.</p> <ul style="list-style-type: none"> • No : Do not reset to the defaults. • Yes : Reset to the defaults.

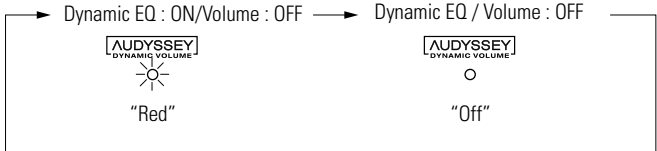

Setting items	Setting contents
Tone Adjust the tonal quality of the sound.	Tone Control : Sets the tone control function ON and OFF. • ON : Allow tone adjustment (treble, bass). • OFF : Playback without tone adjustment.  • This can be set when "Dynamic EQ" (page 83) is set to "OFF". • The tone cannot be adjusted in the direct mode.
	Bass : Adjust low frequency range (bass). • -6dB ~ +6dB  This can be set when "Tone Control" is set to "ON".
	Treble : Adjust high frequency range (treble). • -6dB ~ +6dB  This can be set when "Tone Control" is set to "ON".
Audyssey Settings Set MultEQ XT, Dynamic EQ and Dynamic Volume.	MultEQ XT : Corrects both time and frequency response problems in the listening area. • Audyssey : Optimize the frequency response of all speakers. • Audyssey Byp.L/R : Optimize frequency response of speakers except front L and R speakers. • Audyssey Flat : Optimize frequency response of all speakers to flat response. • Manual : Apply frequency response set with "Manual EQ" (page 85). • OFF : Turn "MultEQ XT" equalizer off.  • "Audyssey", "Audyssey Byp. L/R" and "Audyssey Flat" can be selected after Audyssey Auto Setup has been performed. "Audyssey" is automatically selected after performing Audyssey Auto Setup. "When "Audyssey", "Audyssey Byp.L/R" or "Audyssey Flat" is selected, "AUDYSSEY MULTIEQ XT" lights. • After running Audyssey Auto Setup, if the Speaker Configuration, Distance, Channel Level, and Crossover Frequency have changed without increasing the number of speakers measured, only "AUDYSSEY MULTIEQ XT" lights. • If "Dynamic EQ" or "Dynamic Volume" is set to "ON" when "MultEQ XT" is set to either "OFF" or "Manual", "MultEQ XT" is automatically set to "Audyssey". • You can also press MULTIEQ XT on the main remote control unit to set.
NOTE If you have not performed Auto Setup, or if you change the speaker settings after performing Auto Setup, you may not be able to select Dynamic EQ/Dynamic Volume, and "Run Audyssey" may be displayed. In this case, either perform Audyssey Auto Setup over again or perform "Restore" (page 37) to return to the settings after Audyssey Auto Setup was run.	NOTE • "MultEQ XT" and "Manual" cannot be selected when "EQ Customize" is set to "Not Used" (page 44). • When using headphones, "MultEQ XT" is set to "OFF".

Setting items	Setting contents
Audyssey Settings (Continued)	Dynamic EQ : Solves the problem of deteriorating sound quality as volume is decreased by taking into account human perception and room acoustics. • ON : Use the Dynamic EQ equalizer. • OFF : Do not use the Dynamic EQ equalizer.  • After performing "Audyssey Auto Setup", the "Dynamic EQ" setting automatically becomes "ON". • "AUDYSSEY MULTIEQ XT DYN EQ" is displayed when set to "ON". • When "MultEQ XT" is set to "OFF" or "Manual", "Dynamic EQ" is automatically set to "OFF". • If "Dynamic Volume" is set to "ON", "Dynamic EQ" is automatically set to "ON". • When you set "Dynamic EQ" to "ON", "Tone Control" is switched "OFF". • You can also press DYNAMIC EQ on the main remote control unit to set.
	
	About Dynamic EQ Audyssey Dynamic EQ™ solves the problem of deteriorating sound quality as volume is decreased by taking into account human perception and room acoustics. Audyssey Dynamic EQ works in tandem with Audyssey MultEQ® XT to provide well-balanced sound for every listener at any volume level.

See overleaf

Main remote control unit operation buttons



SEARCH (MENU) : Displaying the menu
Cancel the menu

(Left/Right/Up/Down arrows) : Moves the cursor (Up/Down/Left/Right)

(ENTER) : Confirm the setting

(RTN) : Return to previous menu

Adjusting the Sound and Picture Quality (Audio/Video Adjust)

Setting items	Setting contents
Audyssey Settings (Continued)	<p>Reference Level Offset : Audyssey Dynamic EQ is referenced to the standard film mix level. It makes adjustments to maintain the reference response and surround envelopment when the volume is turned down from 0 dB. However, film reference level is not always used in music or other non-film content. The Dynamic EQ Reference Level Offset provides three offsets from the film level reference (5 dB, 10 dB, and 15 dB) that can be selected when the mix level of the content is not within the standard.</p> <ul style="list-style-type: none"> • 0dB (Film Ref) : This is the default setting and should be used when listening to movies. • 5dB : Select this setting for content that has a very wide dynamic range, such as classical music. • 10dB : Select this setting for jazz or other music that has a wider dynamic range. This setting should also be selected for TV content as that is usually mixed at 10 dB below film reference. • 15dB : Select this setting for pop/rock music or other program material that is mixed at very high listening levels and has a compressed dynamic range. <p> Setting is enabled when "Dynamic EQ" is "ON" (page 83).</p> <p>Dynamic Volume : Solves the problem of large variations in volume level between TV, movies and other content (between quiet passages and loud passages, etc.) by automatically adjusting to the user's preferred volume setting.</p> <ul style="list-style-type: none"> • ON : Use the "Dynamic Volume" equalizer. The Dynamic Volume effect will be at the level of the "Setting" (page 84). • OFF : Do not use the "Dynamic Volume" equalizer. <p> "AUDYSSEY MULTEQ XT DYN VOL" is displayed when set to "ON".</p> <ul style="list-style-type: none"> • When "MultEQ XT" is set to "OFF", "Dynamic Volume" is automatically set to "OFF". • You can also press DYNAMIC VOLUME on the main remote control unit to set. <div style="display: flex; justify-content: space-around; align-items: center;"> <div style="text-align: center;"> <p>Dynamic EQ / Volume : ON</p>  <p>"Green"</p> </div> <div style="text-align: center;"> <p>Dynamic EQ : ON / Volume : OFF</p>  <p>"Red"</p> </div> </div>

Setting items	Setting contents
Audyssey Settings (Continued)	<div style="border: 1px solid black; padding: 5px; margin-bottom: 10px;"> <p style="text-align: center;">About Dynamic Volume</p> <p>Audyssey Dynamic Volume™ solves the problem of large variations in volume level between television programs, commercials, and between the soft and loud passages of movies.</p> <p>Audyssey Dynamic EQ™ is integrated into Dynamic Volume so that as the playback volume is adjusted automatically, the perceived bass response, tonal balance, surround impression, and dialog clarity remain the same.</p> </div> <p>Setting : Set "Dynamic Volume" equalizer effect.</p> <ul style="list-style-type: none"> • Midnight : High setting affects volume the most, causing all sounds to be of equal loudness. • Evening : Middle setting prevents loud and soft sounds from being much louder and softer respectively than average sounds. • Day : Low setting provides the least adjustments to the loudest and softest of sounds. <p> Can be set when "Dynamic Volume" is set to "ON".</p> <hr/> <p>Audyssey DSX Settings Adjust DSX setting and sound stage parameters.</p> <p>DSX : Provides more immersive surround sound by adding the new channels.</p> <ul style="list-style-type: none"> • ON : Set Audyssey DSX to expand surround. • OFF : Do not set Audyssey DSX. <p>Stage Width : Adjust sound stage width when using front wide speakers.</p> <ul style="list-style-type: none"> • -10 ~ 0 <p>Stage Height : Adjust sound stage height when using front height speakers.</p> <ul style="list-style-type: none"> • -10 ~ 0 <p></p> <ul style="list-style-type: none"> • "DSX" can be set when you are using front height speakers or front wide speakers. • "DSX" is valid when using a center speaker. • "DSX" is valid when surround mode is STANDARD mode other than PLIIz Height. • "DSX" can be operated by DSX on the main unit and SPEAKER on the main remote control unit. The "" indicator lights on the display. • "Stage Width" cannot be configured if the HD Audio source being played includes front wide channels. "Stage Height" cannot be configured if the HD Audio source being played includes front height channels. In these case, the respective channels are played back using the input signals.

Setting items	Setting contents
Audyssey DSX Settings (Continued)	<p>About Audyssey Dynamic Surround Expansion (DSX)</p> <p>Audyssey DSX is a scalable surround expansion system that adds new channels to improve the surround impression. Based on research in human hearing DSX adds a pair of Wide channels in the front because that information is critical in the rendering of a realistic soundstage. DSX then adds a pair of Height channels above the main front channels to reproduce the next most important acoustical and perceptual cues related to soundstage depth. In addition to creating these new channels, DSX applies Surround Envelopment Processing to enhance the blend between the front and side/back surround channels. The result is a much more seamless and enveloping home theater experience.</p>
Manual EQ Use the graphic equalizer to adjust the tone of each speaker.	<p>Adjust CH : Correct the tone of each speaker.</p> <ol style="list-style-type: none"> Select the speaker tone adjustment method. All : Adjust the tone of all speakers together. L/R : Adjust the tone of left and right speakers together. Each : Adjust the tone of each speaker. Select the speaker. Select the adjustment frequency band. 63Hz / 125Hz / 250Hz / 500Hz / 1kHz / 2kHz / 4kHz / 8kHz / 16kHz ※ Select the speakers you want to adjust when "L/R" or "Each" is selected. Adjust the level. -20.0dB ~ +6.0dB (0.0dB) <p> Can be set when "MultEQ XT" setting (page 83) is "Manual".</p> <p>Curve Copy : Copy "Audyssey Flat" curve from MultEQ® XT. Yes : Copy. No : Do not copy.</p> <p> "Curve Copy" is displayed after Audyssey Auto Setup has been performed.</p> <p>Default : Reset the settings to the default values. Yes : Reset. No : Do not Reset.</p>

Setting items	Setting contents
RESTORER This function restores compressed audio signals to how they were before compression and corrects the sense of volume of the bass and treble to obtain richer playback sound.	<p>OFF : Do not use RESTORER.</p> <p>Mode 1 (RESTORER 64) : Optimized mode for compressed sources with very weak highs.</p> <p>Mode 2 (RESTORER 96) : Apply suitable bass and treble boost for all compressed sources.</p> <p>Mode 3 (RESTORER HQ) : Optimized mode for compressed sources with normal highs.</p> <p></p> <ul style="list-style-type: none"> This can be set with analog signals or when a PCM signal (fs = 44.1/48 kHz) is input. This cannot be set when the input mode is set to "EXT. IN" or when the surround mode is set to "DIRECT". The default setting for "iPod" and "NET/USB" are "Mode 3". All others are set to "OFF". When set to something other than "OFF", "RSTR" is displayed. This can also be set by pressing RESTORER on the main remote control unit during playback. <div style="text-align: center;"> <pre> graph LR OFF --> M1[Mode 1 (RESTORER 64)] M1 --> M2[Mode 2 (RESTORER 96)] M2 --> M3[Mode 3 (RESTORER HQ)] M3 --> OFF </pre> </div> <p>About the RESTORER function</p> <ul style="list-style-type: none"> Such compressed audio formats as MP3, WMA (Windows Media Audio) and MPEG-4 AAC reduce the amount of data by eliminating signal components that are hard for the human ear to hear. The RESTORER function generates the signals eliminated upon compression, restoring the sound to conditions near those of the original sound before compression. It also corrects the sense of volume of the bass to obtain richer sound with compressed audio signals. This is displayed on the GUI menu and can be set when the input source is set to "NET/USB", or when analog signals (including FM/AM signals) or PCM signals (fs = 44.1/48 kHz) are input.
Audio Delay While viewing video, manually adjust the time to delay audio output.	<p>0ms ~ 200ms</p> <p></p> <ul style="list-style-type: none"> This can be set within the range of 0 to 100 ms when "Auto Lip Sync" is set to "ON" and when a TV compatible with Auto Lipsync is connected. Store "Audio Delay" for each input source.



Adjusting the Sound and Picture Quality (Audio/Video Adjust)



Adjusting the Picture Quality (Picture Adjust) GUI

Default settings are underlined.

- This can be set when the input source is **DVD** **HDP** **TV** **SAT/CBL** **VCR** **DVR** **V.AUX** **NET/USB**.
 ※ With input sources other than the ones above, this can be set when "Video Select" is selected. In this case, the original input source settings are called out.
- Can be set when the "Video Convert" setting (page 60) is "ON".

Setting items	Setting contents
Contrast Adjust picture contrast.	-6 ~ <u>0</u> ~ +6
Brightness Adjust picture brightness.	<u>0</u> ~ +12
Chroma Level Adjust picture chroma level (saturation).	-6 ~ <u>0</u> ~ +6
Hue Adjust color hue.	-6 ~ <u>0</u> ~ +6
DNR Reduce overall picture noise.	<u>OFF</u> / Low / Middle / High
Enhancer Emphasize picture contours.	<u>0</u> ~ +12

- "DNR" and "Enhancer" are each effective with HDMI output.
- The value set at "Picture Adjust" is stored in the memory individually for each input source.





Checking the Status (Information)



Setting items	Setting contents
Status Shows information about current settings.	<ul style="list-style-type: none"> <input type="checkbox"/> MAIN ZONE Shows information about settings for MAIN ZONE. The items displayed differ according to the input source. Zone Rename / Select Source / Name / Surround Mode / Input Mode / Decode Mode / HDMI / Digital / Component / iPod dock / Rec Select / Video Select / Video Convert / i/p Scaler / Resolution / Progressive Mode / Aspect etc. <input type="checkbox"/> ZONE2 / ZONE3 / ZONE4 Shows information about settings for multi-zone. Zone Rename / Power / Select Source / Volume Level
Audio Input Signal Shows information about audio input signals.	<p>Surround Mode : The currently set surround mode Signal : The input signal type fs : The input signal's sampling frequency Format : The number of channels in the input signal (front, surround, LFE) Offset : The dialogue normalization correction value Flag : This is displayed when inputting signals including a surround back channel. "MATRIX" is displayed with Dolby Digital EX and DTS-ES Matrix signals, "DISCRETE" with DTS-ES Discrete signals.</p> <div style="border: 1px solid black; padding: 5px; margin: 10px 0;"> <p style="text-align: center;">Dialogue normalization function</p> <p>This is automatically activated when playing Dolby Digital sources. This function automatically corrects the standard signal level for individual program sources. The correction value can be checked using the STATUS on the main unit.</p> <div style="border: 1px solid black; padding: 5px; margin: 10px auto; width: fit-content;"> <p style="text-align: center;">Dial.Norm Offset - 4dB</p> </div> <p>The figure is the correction value when the standard level is corrected.</p> </div>
HDMI Information Shows information about HDMI input/output signals and monitor.	<p>Signal Info.</p> <ul style="list-style-type: none"> • Resolution / Color Space / Pixel Depth Monitor 1 / Monitor 2 • Interface / Supported resol.

Setting items	Setting contents
Auto Surround Mode Shows information about auto surround mode settings.	<p>Analog/PCM 2ch / Digital 2ch / Digital 5.1ch / Multi ch</p> <p> This can be displayed when "Auto Surround Mode" is set to "ON".</p>
Quick Select Shows information about "Saving Frequently Used Settings (Quick Select Function)" (page 91, 98) settings.	<p>Quick Select 1 / Quick Select 2 / Quick Select 3 / ZONE2 Quick Select / ZONE3 Quick Select / ZONE4 Quick Select</p> <ul style="list-style-type: none"> • Select Source / Video Select / MultEQ XT / Dynamic EQ / Dynamic Volume / Auto Surround Mode (Analog/PCM 2ch / Digital 2ch / Digital 5.1ch / Multi ch) / Volume Level
Preset Channel Shows information about preset channels.	<p>This can be checked when the input source is set to TUNER NET/USB.</p> <p>A / B / C / D / E / F / G</p> <ul style="list-style-type: none"> • A1 ~ A8 / B1 ~ B8 / C1 ~ C8 / D1 ~ D8 / E1 ~ E8 / F1 ~ F8 / G1 ~ G8

Getting Started

Connections

Settings

Playback

Multi-zone

Remote Control

Information

Troubleshooting

Specifications



Other Operations and Convenient Functions

Symbols used to indicate buttons in this manual

- Button located on both the main unit and the remote control unit → **BUTTON**
- Button only on the main unit → **<BUTTON>**
- Button only on the remote control unit → **[BUTTON]**

<SOURCE SELECT> <ZONE2/3/4 / REC SELECT>

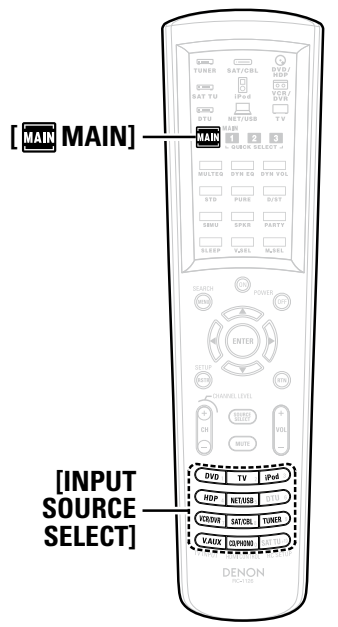
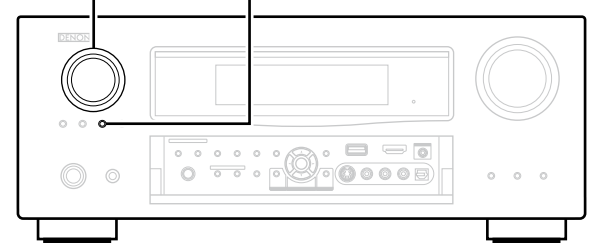

Other Operations

Playing a Blu-ray Disc Player Compatible with DENON LINK 4th

To play DENON LINK 4th signals, make HDMI and DENON LINK connections with the compatible Blu-ray disc player.

DENON LINK 4th uses the clock of the AV amplifier connected by DENON LINK to achieve HDMI signal transfer with little jitter when playing BD.

- 1 Assign "HDMI" to the input source to be used, and assign "D.LINK" to the "Digital" setting (page 58 "Input Assign").**
- 2 Set "HDMI Control" – "Control" (page 43) to "ON".**
- 3 Either turn <SOURCE SELECT> or press [INPUT SOURCE SELECT] to select the input source assigned in step 1.**
The "HDMI" indicator lights on the display.
- 4 Set "Input Mode" (page 61) to "AUTO".**
- 5 Select the surround mode (page 78 "Selecting the Surround Mode (Surround Mode)").**
- 6 Start playing the BD.**
Playback starts.

- NOTE**
- Set the Blu-ray disc player's "HDMI Control" setting to "ON", the "DENON LINK" setting to "4th". For instructions on operation, refer to the Blu-ray disc player's manual.
 - The jitter-free function does not work except during BD playback. In this case, the video signal is output from the HDMI OUT terminal, and the audio signal from the DENON LINK terminal.
 - When a BD is played with the input mode set to "Auto", playback is performed in the DENON LINK 4th mode. When a disc other than a BD is played with the input mode set to "Auto", playback is automatically performed in the DENON LINK 3rd mode.
 - When the input mode is set to "HDMI", normal HDMI playback is performed.
 - When the input mode is set to "Digital", playback is fixed to the DENON LINK 3rd mode and BDs cannot be played.

Playing Super Audio CD

- 1** Either assign the input source to be used to “HDMI” (🔍 page 58), or assign “D.LINK” at the “Digital” setting (🔍 page 58 “Input Assign”).
- 2** Either turn <SOURCE SELECT> or press [INPUT SOURCE SELECT] to select the input source assigned in step 1.
The “**D.LINK**” or “**HDMI**” indicator lights on the display.
- 3** Select the surround mode (🔍 page 78 “Selecting the surround mode”).
※ We recommend playing in the DIRECT mode.
- 4** Start playing the Super Audio CD.
The “**DSD**” indicator lights on the display.
※ For operating instructions, refer to the respective equipment’s operating instructions.



- When playing DSD signals in the DIRECT or PURE DIRECT mode, the DSD signals are converted as such into analog signals. When playing in other surround modes, the DSD signals are first converted into PCM format, then into analog signals.
- “DSD DIRECT” is shown on the display when playing DSD 2-channel signals in the DIRECT mode. “DSD MULTI DIRECT” is shown on the display when playing DSD multi-channel signals in the DIRECT mode.

Recording on an External Device (REC OUT mode)

When using the audio/video recording connectors (VCR or DVR outputs), you can record the audio or video from a different program source while listening to the currently played track.

- 1** Press <ZONE2/3/4 / REC SELECT>.
“ZONE2 SOURCE” is shown on the display.
 - 2** Turn <SOURCE SELECT> until “RECOUT SOURCE” is displayed.
The “REC” indicator lights.
-
- 3** Turn <SOURCE SELECT> to choose the input source to be recorded.
 - 4** Play the program source.
※ For operating instructions, refer to the respective equipment’s operating instructions.
※ To record FM or AM broadcasts, select the broadcast (🔍 page 67).
 - 5** Start recording.
※ For operating instructions, refer to the respective equipment’s operating instructions.



- To cancel, press <ZONE2/3/4 / REC SELECT>, then turn <SOURCE SELECT> until “ZONE2 SOURCE” is displayed.
- Make a test recording before starting the actual recording.
- Signals are only output to the analog REC OUT connectors when the digital signals input to the digital input connectors (OPTICAL/COAXIAL) are PCM (2-channel) signals.
- As the digital audio signal input from the HDMI connector is not output to the digital recording connector (OPTICAL), you should connect using the OPTICAL and COAXIAL connectors.
- Sources selected with the REC OUT mode are output from ZONE2 as well.
- In the REC OUT mode, the remote control unit’s ZONE2 mode buttons cannot be operated.

NOTE

- Recordings you make are for your personal enjoyment and should not be used for other purposes without permission of the copyright holder.
- Input sources for which “Delete” is selected at “Source Delete” (🔍 page 52) cannot be selected.

Convenient Functions

Symbols used to indicate buttons in this manual

- Button located on both the main unit and the remote control unit → **BUTTON**
- Button only on the main unit → **<BUTTON>**
- Button only on the remote control unit → **[BUTTON]**

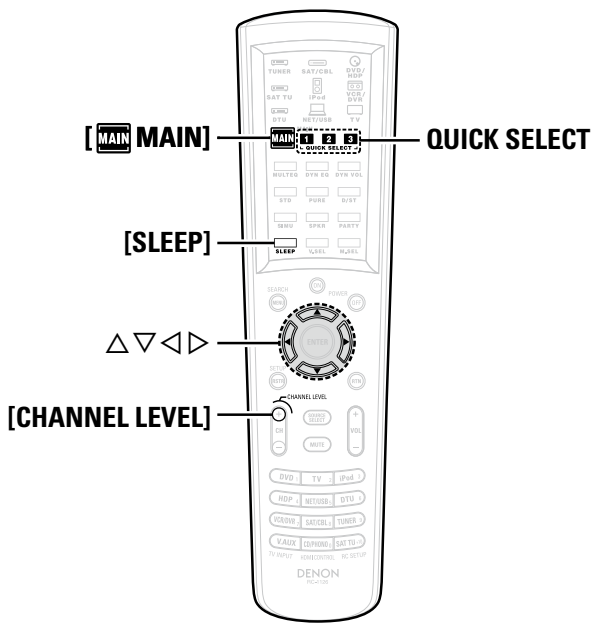
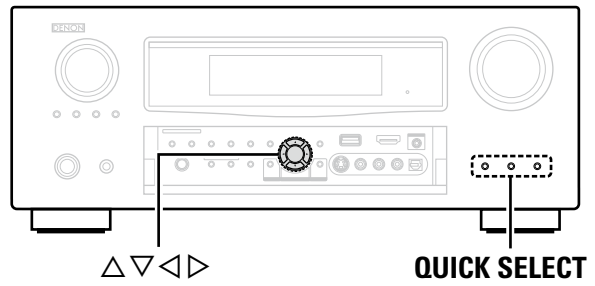

HDMI Control Function

When you make an HDMI connection with a TV or player compatible with AVR-4810 and HDMI control functions, you can perform the following operations by setting the HDMI control function of each device.

- AVR-4810 power off can be linked to the TV power off step.**
When you set "Output audio from amp" in the TV audio output setup operation, you can switch the amp power on.
- You can switch audio output devices with a TV operation.**
- You can adjust AVR-4810 volume in the TV volume adjustment operation.**
- You can switch AVR-4810 input source through linkage to TV input switching.**
- When playing the player, the AVR-4810 input function switches to the function of that player.**

- When you want to listen to TV audio by AVR-4810, connect optical digital or analog audio (page 21 "TV").
- When using these functions set as follows: "HDMI Control" – "Control" (page 43) set to "ON".

NOTE

- When "Control" is set to "ON", it consumes more standby power.
- The HDMI control function controls operations of a TV that is compatible with the HDMI control function. Make sure that the TV and HDMI are connected when you perform HDMI control.
- When you power off AVR-4810, the HDMI control function does not operate. Either power on or set to standby.
- Some functions may not operate depending on the connected TV or player. Check the owner's manual of each device for details beforehand. Please refer to the DENON website for information on compatible equipment.
- When "Control" is set to "ON", it is not possible to assign an HDMI terminal to "TV" at "Input Assign" (page 58).

- 1 Turn the power on for all the equipment connected by HDMI cable.**
- 2 Set the HDMI control function for all equipment connected by HDMI cable.**
Set "HDMI Control" – "Control" (page 43) to "ON".
※ Please consult the operating instructions for the connected equipment to check the settings.
※ Carryout steps 1 and 2 should any of the equipment be plugged out.
- 3 Switch the television input to the HDMI connected to the AVR-4810.**
- 4 Switch the AVR-4810 input to the HDMI input source and check if the picture from the player is ok.**
- 5 When you turn the TV's power to standby, check that the power of the AVR-4810 and player also goes on standby.**

- If the HDMI control function does not operate properly, check the following points.
 - Is the TV or player compatible with the HDMI control function?
 - Is the AVR-4810 properly set?
 - Is the "HDMI Control" – "Control" (page 43) set to "ON"?
 - Is the "Power Off Control" (page 43) set to "ON"?
 - Is the "Control Monitor" (page 43) set for the monitor output connected to television?
 - In the case of dual monitor connection, is the "Control Monitor" (page 43) on the GUI menu set to a monitor without HDMI control?
 - Are the HDMI control function settings of all equipment correct?

NOTE

- Should any of the operations below be performed, the interlocking function may be reset, in which case, repeat step's 1 and 2.
 - "Input Assign" – "HDMI" (page 58) setting has changed.
 - "Monitor Out" (page 42) setting is changed.
 - There is a change to the connection between the equipment and the HDMI, or an increase in equipment.

Setting the Power to Standby After a Certain Amount of Time (Sleep Timer Function)

With this function, you can set the AVR-4810 so that the power is automatically switched to standby after the set amount of time has passed.

This is convenient for playing sources while going to sleep.

Press [SLEEP] and display the time you want to set.

The "SLEEP" indicator on the display lights.

- The time switches as shown below each time [SLEEP] is pressed.

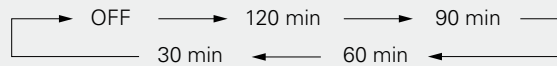

❑ To cancel the sleep timer

Press [SLEEP] to set "OFF".

The "SLEEP" indicator on the display turns off.



- The sleep timer setting is canceled if the AVR-4810's power is set to standby or turned off.
- The sleep timer function can be set separately for the different zones (page 99 "Sleep Timer Function").

Adjust the Volume of the Speakers

You can adjust the channel level either according to the playback sources or to suit your taste, as described below.

Adjust the Volume of the Different Speakers

1 Press [CHANNEL LEVEL].

2 Use Δ ∇ to select the speaker.

The speaker that can be set switches each time one of the buttons is pressed.

3 Use \triangleleft \triangleright to adjust the volume.

※ In the case of a subwoofer, press \triangleleft when it is at "-12 dB" will change the setting to "OFF".



When a headphone jack is inserted, the headphone channel level can be adjusted.

Adjusting the Volume of Groups of Speakers (Fader Function)

This function lets you adjust (fade) the sound from all the front (Front speaker / Front height speaker / Front wide speaker / Center speaker) or rear (Surround speaker / Surround Back speaker) speakers at once.

1 Use ∇ to select "Fader", then select the item to be adjusting using \triangleleft or \triangleright .

2 Use \triangleleft \triangleright to adjust the volume of the speakers. (\triangleleft : front, \triangleright : rear)



- The fader function does not affect the subwoofer.
- The fader can be adjusted until the volume of the speaker adjusted to the lowest value is -12 dB.

Saving Frequently Used Settings (Quick Select Function)

All of the settings in step 1 can be memorized together. By memorizing frequently used settings, you can quickly access and enjoy a playback environment that is consistently the same.

Saving the Settings

1 Set the items below to the settings you want to save.

- Input Source (page 30)
- Volume Level (page 76)
- Surround Mode (page 78)
- Audyssey Setting (MultEQ[®] XT, Dynamic EQ[™], Dynamic Volume[™]) (page 83, 84)
- Video Select (page 60)

2 Press and hold the desired QUICK SELECT until "Memory" appears on the display.

The current settings will be memorized.

[Quick Select Defaults]

	Input Source	Volume
Quick Select 1	DVD	-40dB
Quick Select 2	SAT/CBL	-40dB
Quick Select 3	VCR	-40dB

Calling the Settings Out

Press QUICK SELECT at which the settings you want to call out are saved.

The "Q1", "Q2" or "Q3" indicator lights on the display.

❑ Naming Quick Select settings

See "Quick Select Name" (page 54).



The Quick Select function can be set separately for the different zones (page 98 "Quick Select Function").

NOTE

Input sources stored with the quick select function cannot be selected if they have been deleted at "Source Delete" (page 52). In this case, store them again.

Convenient Functions

Symbols used to indicate buttons in this manual

- Button located on both the main unit and the remote control unit → **BUTTON**
- Button only on the main unit → **<BUTTON>**
- Button only on the remote control unit → **[BUTTON]**

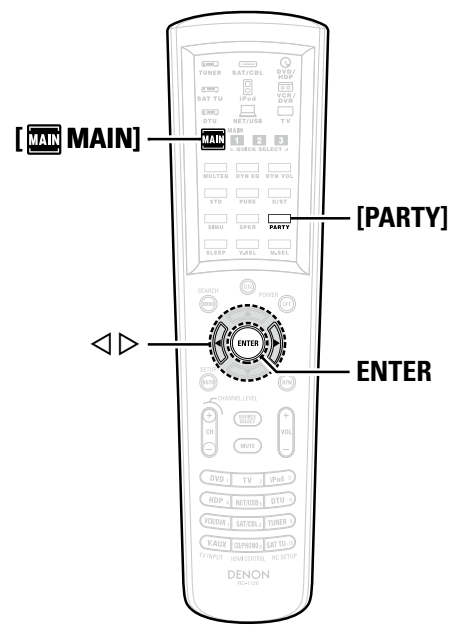
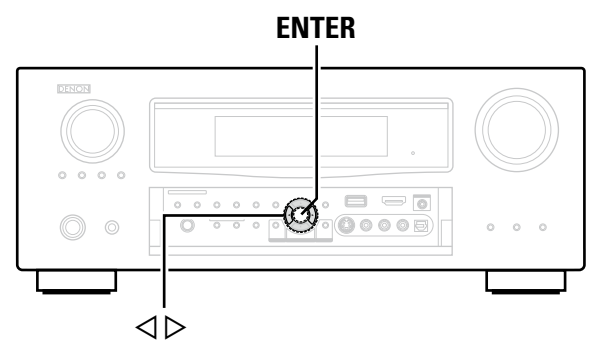

Playing the Same Network Audio on Different Devices Connected in a Network (Party Mode Function)

The same network audio (Internet Radio, Media Server or iPod DIRECT) can be played on multiple DENON products equipped with the Party Mode function and connected in a network. The party mode consists of one organizer and up to four attendees. When one unit starts the party mode as the organizer, up to four devices on which the party mode function is activated automatically participate in the party as attendees. "Party Mode Function" (page 49) must be set to "ON" ahead of time in order to use the party mode function.

Starting the Party Mode as the Organizer

- 1 Press [PARTY] to become the organizer.**
"Enter Party Mode?" is displayed.
※ An error message is displayed when you are not connected to a network.
- 2 Press <> to select "Yes", then press ENTER.**
The "**PARTY ORGANIZER**" indicator on the display lights. The input source automatically switches to "NET/USB" and the attendees are automatically selected.
- 3 Play the desired track.**

To Cancel the Party Mode

- 1 While in the party mode, press [PARTY].**
"Exit Party Mode?" is displayed on the GUI screen.
- 2 Press <> to select "Yes", then press ENTER.**
"Power off Attendees component?" is displayed.
- 3 Press <> to select "Yes" or "No", then press ENTER.**
 - Yes** : The power of the attendees is turned off and the party mode is canceled.
 - No** : The party mode is canceled without turning off the power of the attendees.

Participating in the Party Mode as an Attendee

- When the organizer starts the party mode, up to four attendees are selected automatically. No operation is required.
- When a device becomes an attendee, "**PARTY ATTENDEE**" appears on the display. The input source automatically switches to "NET/USB" and the same network audio as on the organizer is played.
- If there are fewer than four attendees, a device can join the party mode after it has started. To participate in the party mode, perform the operation described below.

- 1 Press [PARTY].**
"Enter Party Mode?" is displayed.
※ An error message is displayed when you are not connected to a network.

- 2 Press <> to select "Yes", then press ENTER.**

To Cancel the Party Mode

- 1 While in the party mode, press [PARTY].**
"Exit Party Mode?" is displayed on the GUI screen.
- 2 Press <> to select "Yes", then press ENTER.**
In this case, the other devices remain in the party mode.

"Napster" and "USB" are not available in the Party Mode. There can only be one organizer in the network. To form a new party mode, first cancel the current party mode.

Operating a Wireless LAN-Compatible Mobile Terminal to Play Music and Still Pictures

- Perform this procedure using a wireless LAN-compatible mobile terminal conforming to the DLNA (Digital Living Network Alliance) standard.
- This function allows you to play contents located on a computer (music server) or mobile terminal device connected in a network by operating a mobile terminal device in the same network.
- There are two types of operations on the mobile terminal device.

Playing Contents on a Computer (Media Server)

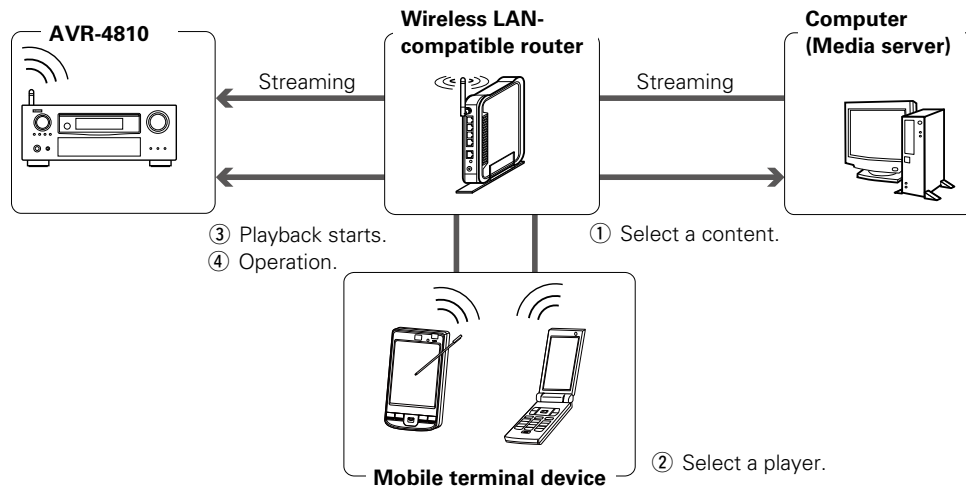

1 From the mobile terminal device, browse the media server in the same network and choose the contents you want to play.

2 From the mobile terminal device, select the AVR-4810 among the products in the network.

Playback of the contents selected in step 1 begins.

- ※ When selecting the AVR-4810 from the mobile terminal device, the name of the AVR-4810 is displayed at "Friendly Name" (☞ page 49 "Friendly Name Edit").
- ※ The following operations are possible from the mobile terminal device:
 - File operations (play, stop, pause, track search)
 - Play mode settings (repeat/random)
 - Volume adjustment

Playing Contents on a Mobile Terminal Device

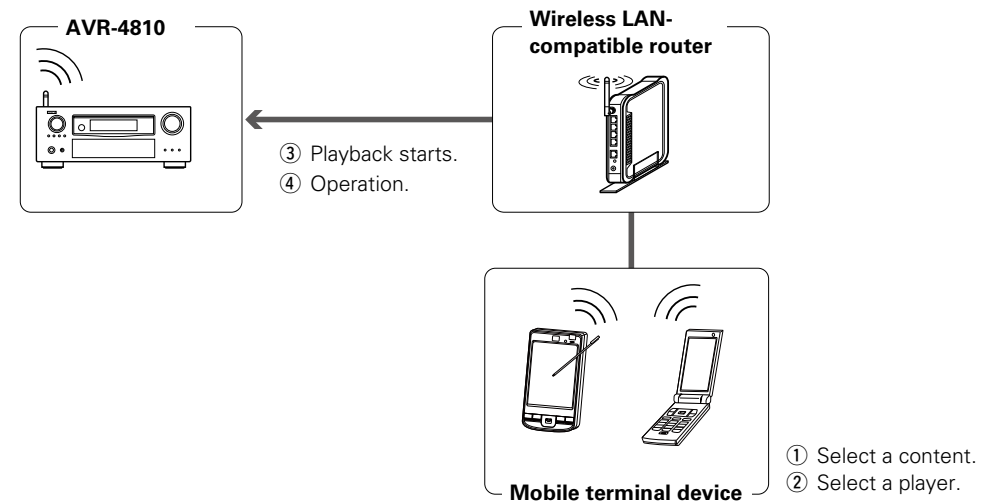

1 Select the contents you want to play from among the mobile terminal devices.

2 From the mobile terminal device, select the AVR-4810 among the products in the network.

Playback of the contents selected in step 1 begins.

- ※ When selecting the AVR-4810 from the mobile terminal device, the name of the AVR-4810 is displayed at "Friendly Name" (☞ page 49 "Friendly Name Edit").
- ※ The following operations are possible from the mobile terminal device:
 - File operations (play, stop, pause, track search)
 - Play mode settings (repeat/random)
 - Volume adjustment



- "📶" is displayed on the GUI screen while the mobile terminal device is being operated.
- For the various settings and operating procedures, see the operating instructions of the mobile terminal devices being used.
- When selecting the AVR-4810 from the mobile terminal device, the name of the AVR-4810 is displayed at "Friendly Name". "Friendly Name" can be edited at "Friendly Name Edit" (☞ page 49) as desired so that it is easily distinguishable from other devices.
- When playback is started from the mobile terminal device, the AVR-4810's input source automatically switches to "NET/USB". Also, when the "Network Standby" setting (☞ page 49) is set to "ON", the power automatically turns on.

NOTE

When operations related to browsing or playback (play, stop, pause, track search) are performed on the AVR-4810 while operating the mobile terminal device, the connection to the network is disconnected. The network connection is also disconnected when the party mode is started.

Getting Started
Connections
Settings
Playback
Multi-zone
Remote Control
Information
Troubleshooting
Specifications

Convenient Functions

Operating the AVR-4810 with a Browser (Web Control Function)

You can operate the AVR-4810 using a browser.

1 Switch “ON” the “Network Standby” setting (☞ page 49).

2 Check the AVR-4810’s IP address with “Network Information” (☞ page 50).

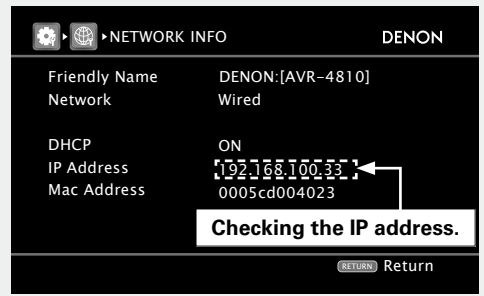

3 Enter the AVR-4810 IP address in browser’s address box.

For example, if the IP address of AVR-4810 is “192.168.100.33”, enter “http://192.168.100.33”.

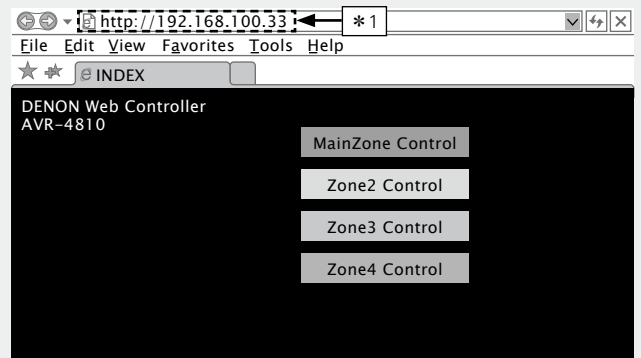

* 1: Entering the IP address.

4 When the top menu is displayed, click on the menu you want to operate.

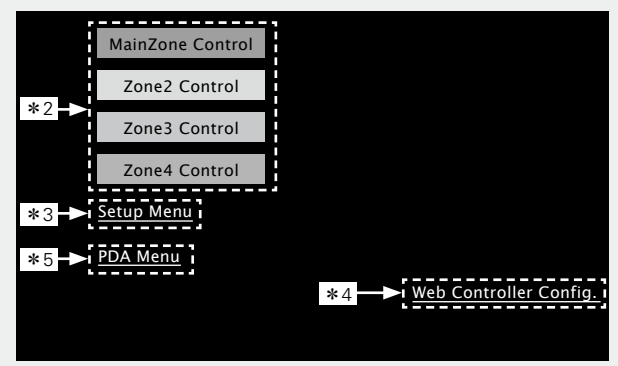

- * 2: Click when you operate each zone (☞ [Example 1])
- * 3: Click when you operate the setup menu (☞ [Example 2])
- * 4: Click to change the Web control screen setting. (☞ [Example 3])
- * 5: Click when you operate a small screen such as a PDA screen, etc. (☞ [Example 4])

5 Operate.

[Example 1] Main zone control screen

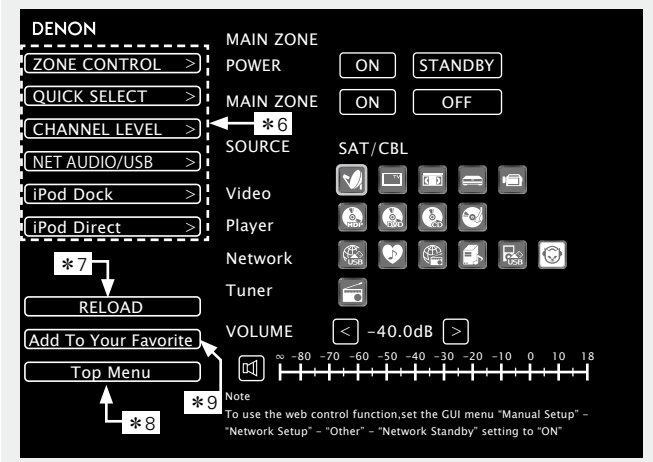

- * 6: Click to perform each operation.
Changes to each operation screen (☞ [Example 5])
- * 7: Click when you update to the latest information.
Normally, there is a change to the latest information each time you operate. When operated from the main unit, click because the screen is not updated.
- * 8: Click to return to the top menu.
Displayed when setting “Top Menu Link Setup” to “ON” in [Example 3]
- * 9: Click to add a setting to the “Favorites” in your browser.
We recommend registering the setting screens for the different zones in the browser’s favorites so as not to accidentally perform menu operations for zones you do not intend to operate.

[Example 2] Setup menu screen

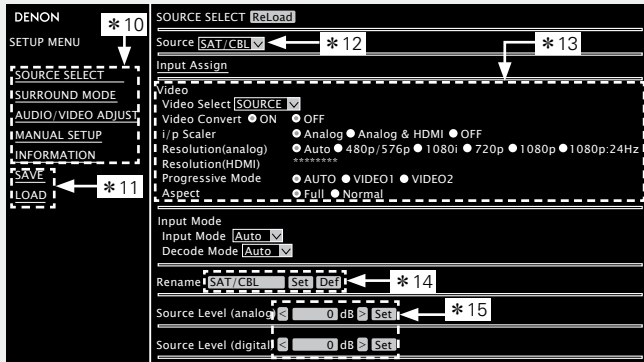

- * 10: Click the menu from which you want to make settings. The display on the right becomes each setting screen.
- * 11: Click "SAVE" when you want to save settings, and click "LOAD" when you want to call settings. Becomes each operation screen.
- * 12: Click "v" and select from the displayed items.
- * 13: Click to determine a setting.
- * 14: After entering characters, click "Set" to set, or click "Def" to return to initial setting.
- * 15: Enter figures or click "<" or ">" to make the setting, and then click "Set".

[Example 3] Web configuration screen

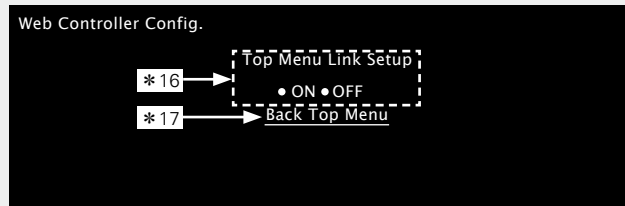

- * 16: Click "ON" when performing Top Menu Link Setup. When set up, return to the top menu from each operation screen. (Default setting: "OFF")
- * 17: Click to return to the top menu.

[Example 4] PDA menu screen

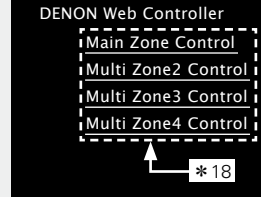

- * 18: Select to operate each zone.

NOTE

You cannot change setup menu operations and zone name on the PDA menu screen.

[Example 5] Net Audio operating screen

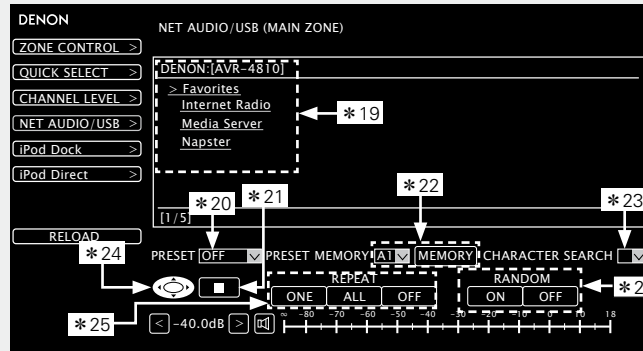

- * 19: Click the menu from which you want to make settings.
- * 20: Click "v" to select the preset channel you want to play.
- * 21: Click to stop play.
- * 22: When registering presets, click "v" to select the channel you want to register, and then click "MEMORY".
- * 23: When searching using an acronym, click "v" and select from the displayed characters.
- * 24: Click when selecting menu.
- * 25: Click to repeat play.
- * 26: Click to random play.

[Example 6] Dedicated iPod Touch screen

※ When accessed from the iPod Touch browser, an optimized operation screen is displayed.



Various Memory Functions

Personal Memory Plus Function

This function sets the settings (input mode, surround mode, MultEQ XT, Dynamic EQ, Dynamic Volume, audio delay etc.) last selected for the individual input sources.

Last Function Memory

This stores the settings as they were directly before the standby mode was set. When the power is turned back on, the settings are restored to as they were directly before the standby mode was set.

Playing in ZONE2/ZONE3/ZONE4 (Multi-zone Function)

This function allows you to play sound in rooms other than the main zone where multi-channel sound is played.



The source selected for ZONE2 is also output from the recording output connectors.

Audio Output

There are two methods to do this, as described below. Choose one of the methods.

- ① Zone playback by speaker output
- ② Zone playback by audio output (PRE OUT / OPT OUT)
Use an external amplifier.

① Zone Playback by Speaker Output

The ZONE2 and ZONE3 audio signals are output from the AVR-4810's SURR BACK/AMP ASSIGN speaker terminals using the amplifier assignment function.

Connecting and Setting the Speakers

	"Amp Assign" mode setting (page 39) and the audio signals that are output	Connecting the speakers
ZONE2	ZONE2 Output signal : Stereo (L / R)	
ZONE3	ZONE3 Output signal : Stereo (L / R)	
ZONE2 and ZONE3	※ Mono signals are outputted when "Amp Assign" - "Assign Mode" is set to "FREE" and the signal assigned to the power amp is set to "Z2/Z3 (M)".	

② Zone Playback by Audio Output (PRE OUT / OPT OUT)

Audio Connections (ZONE2, ZONE3)

The audio signals of the AVR-4810's ZONE2 and ZONE3 audio output terminals are output to the ZONE2 and ZONE3 amplifiers and played on these amplifiers.

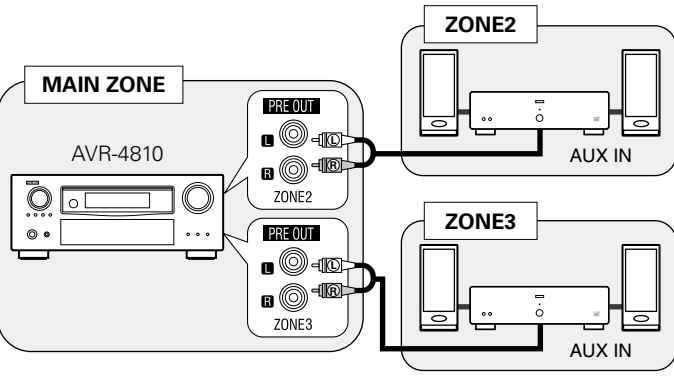

Also be sure to read the operating instructions of the connected devices.

NOTE

- We recommend using high quality pin-plug cables for audio connections in order to prevent noise.
- When the input source to which the digital input connectors (OPTICAL/COAXIAL) are assigned is selected in ZONE2 or ZONE3, playback is only possible if the digital signal being input is in PCM (2-channel) format.
- It is not possible to play the digital audio signals input from the HDMI or DENON LINK terminals in ZONE2 and ZONE3.
- When certain digital signals are being input, noise may be output from the ZONE2 and ZONE3 audio output connectors.
- In ZONE4, it is not possible to select the sources with no digital input signals ("TUNER", "PHONO", "iPod", etc.).

Digital Audio Connections (ZONE4)

- Connect audio from the ZONE4 OPTICAL OUT terminal on the AVR-4810 to the ZONE4 amp.
- Use bitstream compatible amps in ZONE4.

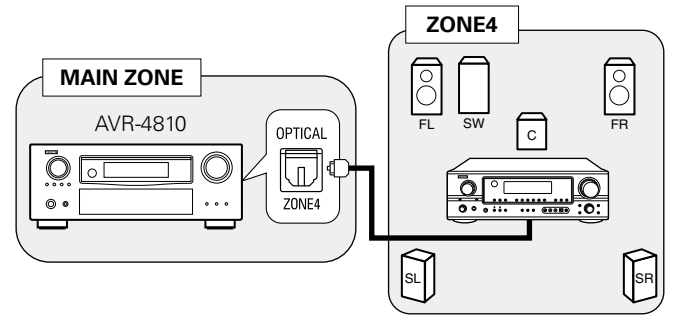

Video Output

Video Connection

The video signals of the AVR-4810's ZONE2 video output terminal are played by the ZONE2 monitor.

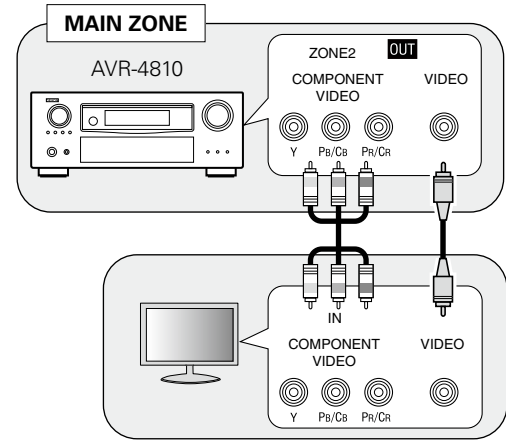

NOTE

It is not possible to output video signals input to the HDMI to ZONE2.

Symbols used to indicate buttons in this manual

- Button located on both the main unit and the remote control unit → **BUTTON**
- Button only on the main unit → **<BUTTON>**
- Button only on the remote control unit → **[BUTTON]**

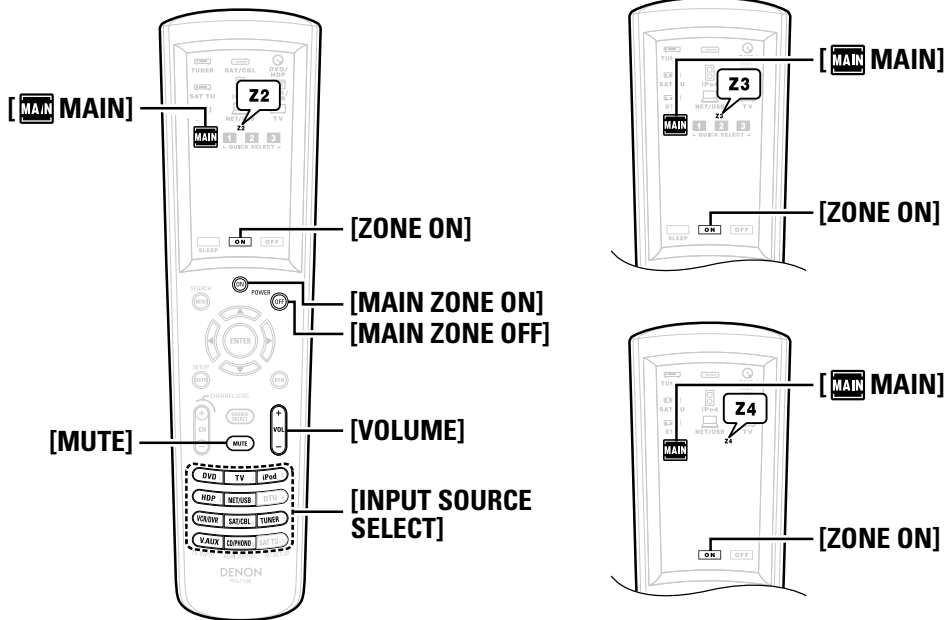
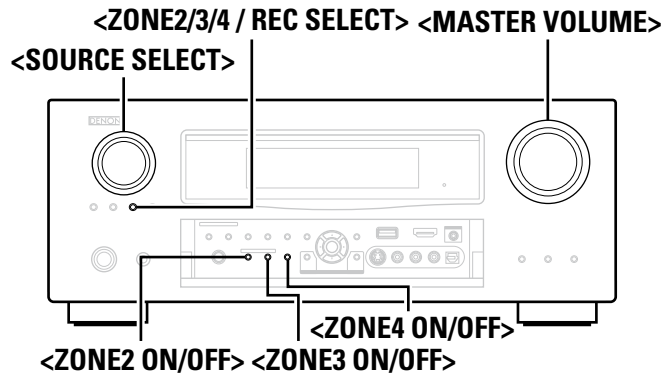

Sub remote control unit

Playback

The operating procedure is the same for “① Zone Playback by Speaker Output” and “② Zone Playback by Audio Output (PRE OUT)”.

1 Turn on the AVR-4810’s power.
 (☞ page 27 “Turning the Power On”)

2 Turn on the zone power.

Operation on the main unit
 Press **<ZONE2 ON/OFF>**, **<ZONE3 ON/OFF>** or **<ZONE4 ON/OFF>** for the zone to be operated.

When the power turns on, the “**Z2**”, “**Z3**” or “**Z4**” indicator lights on the display.

Operation on the remote control unit
 Press **[MAIN]** to display the mode for the zone to be operated, the press **[ZONE ON]**.

When the power turns on, the “**Z2**”, “**Z3**” or “**Z4**” indicator lights on the display.

※ Also press **[INPUT SOURCE SELECT]** when in standby mode, the power turns on.
 ※ When using ZONE2, ZONE3 or ZONE4, it is possible to turn the power for the MAIN ZONE only on or off by pressing **[MAIN ZONE ON]** or **[MAIN ZONE OFF]**.

3 Select the input source.

Operation on the main unit
 ① Press **<ZONE2/3/4 / REC SELECT>** and select the zone to be adjusted.
 ② Turn **<SOURCE SELECT>** to choose the input source.

Operation on the remote control unit
 In the zone mode you want to operate, press **[INPUT SOURCE SELECT]**.

※ The same input source as in the main zone can be selected easily by pressing the **[M.ZONE CALL]** on the sub remote control unit.

4 Adjust the item below.

Adjust the Volume

Operation on the main unit

- Press **<ZONE2/3/4 / REC SELECT>** and select the zone to be adjusted.
- Turn **<MASTER VOLUME>** to adjust.

Operation on the remote control unit

In the zone mode whose volume you want to adjust, press **[VOLUME]**.

[Adjustable range]

--- **-80dB ~ -40dB ~ 18dB**

(When the “Volume Display” setting is “Relative”)

[Adjustable range] 0 ~ 41 ~ 99

(When the “Volume Display” setting is “Absolute”)

※ Upon purchase, “Volume Limit” is set to “-10dB (71)”.

Turning off the Sound Temporarily (MUTE)

In the zone mode for which you want to mute the sound, press **[MUTE]**.

The sound is reduced to the level set at menu “Mute Level” (☞ page 52).

※ To cancel, either adjust the volume or press **[MUTE]** again.

※ The setting is canceled when the zone’s power is turned off.

※ The volume can be adjusted in ZONE2 and ZONE3.

Symbols used to indicate buttons in this manual

Button located on both the main unit and the remote control unit → **BUTTON**
 Button only on the main unit → **<BUTTON>**
 Button only on the remote control unit → **[BUTTON]**

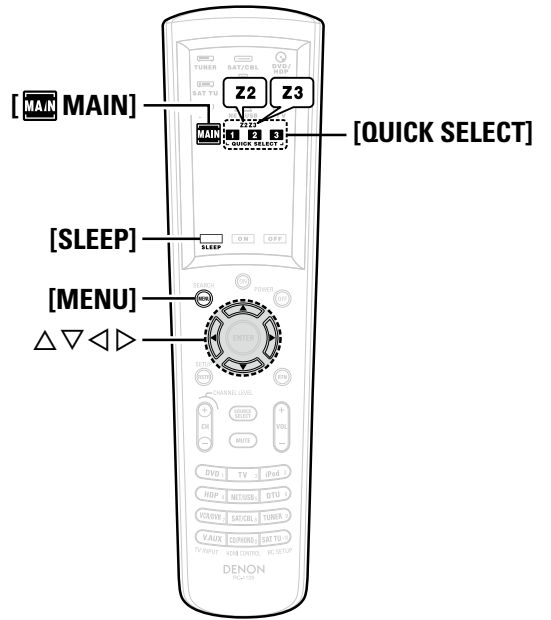
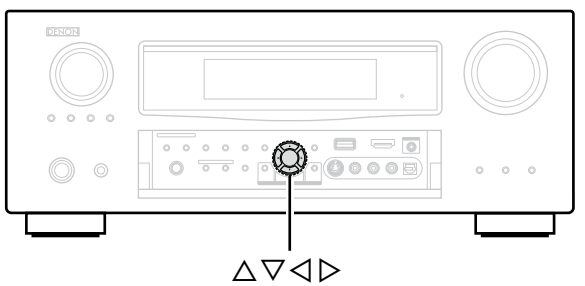

Menu Operation

The settings related to tone adjustment and volume can be made.

- 1 In the zone mode for which you want to operate, press [MENU].**
The ZONE2 or ZONE3 menu is displayed on the ZONE2 monitor.

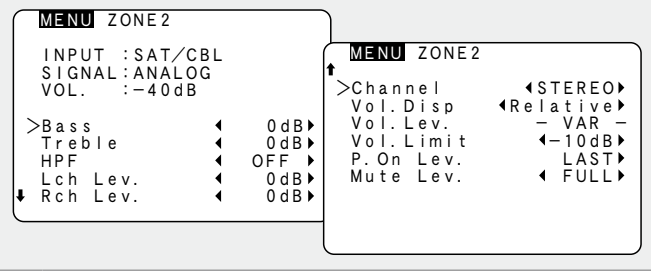

- 2 Press $\Delta \nabla \triangleleft \triangleright$ to select the menu to be set or operated.**

- 3 Press [MENU] to enter the setting.**
The on-screen display disappears.

For ZONE2, the “Zone Setup” can be made while watching the on-screen display. Also, when ZONE3 is operated, the on-screen display appears on the ZONE2 monitor, so operation can be performed watching this on-screen display.

Quick Select Function

It is also possible to save three settings for multi-zone.

- 1 Set the items below to the settings you want to save.**
 - 1 Input Source** (🔗 page 97)
 - 2 Volume Level** (🔗 page 97) (except for ZONE4)

- 2 In the zone mode for which you want to operate, press and hold the desired [QUICK SELECT] until “Memory” appears on the on-screen display or display.**
The current settings will be memorized.

[Quick Select Defaults]

	Input Source	Volume
Z2/Z3/Z4 Quick Select 1	DVD	-40dB
Z2/Z3/Z4 Quick Select 2	SAT/CBL	-40dB
Z2/Z3 Quick Select 3	VCR	-40dB
Z4 Quick Select 3	DVR	-40dB

Calling the Settings Out

Press [QUICK SELECT] at which the settings you want to call out are saved.

- Naming Quick Select settings**
See “Quick Select Name” (🔗 page 54).

- In ZONE4, only input sources to which NET/USB and digital input have been assigned can be selected.
- Use the sub remote control when performing Quick Select memory or call-up in ZONE4.

Sleep Timer Function

This is useful when you want to sleep while listening in ZONE2 or ZONE3.

In ZONE4, the power switches off by interfacing with the MAIN ZONE sleep timer settings.

1 Press [MAIN] to display the mode for the zone to be operated.

2 Press [SLEEP] and display the time you want to set.
The time switches as shown below each time [SLEEP] is pressed.

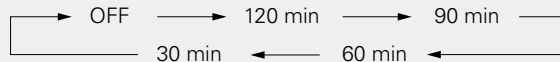

To cancel the sleep timer
Press [SLEEP] to set "OFF".



The sleep timer is also canceled when the AVR-4810 is set to the standby mode or the ZONE2 or ZONE3 power is turned off.

Operating the Connected Devices by Remote Control Unit

Operating the Main Remote Control Unit

- On the main remote control unit, the display switches according to the device being operated and the mode.
- In the "MAIN", "TUNER", "iPod" and "NET/USB" modes, when the remote ID is set, the AVR-4810 can be used independently even in an environment containing multiple DENON amplifiers. (See page 104 "Setting the Remote ID")

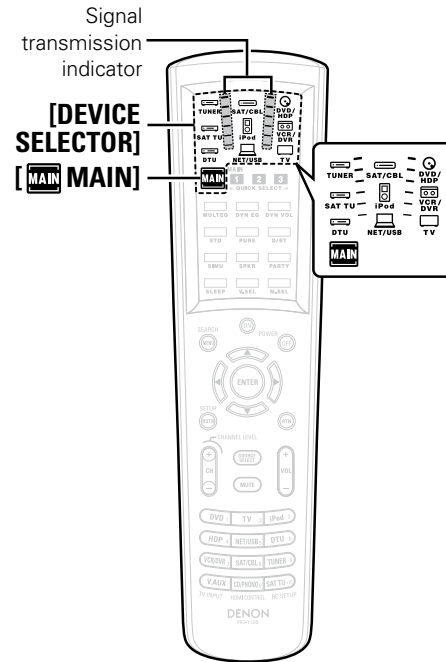

Operating AV Equipment

1 Press [DEVICE SELECTOR] for the component to be operated.
The indicator for the component to be operated flashes.

- : MAIN / ZONE2 / ZONE3 / ZONE4 / MACRO
- : TUNER (FM/AM)
- : Cannot be used.
- : Cannot be used.
- : Satellite Receiver / Cable Tuner / IPTV / HDTV (Set Top Box)
- : iPod
- : Network / USB
- : Blu-ray Disc Player / HD DVD Player / DVD Player (Recorder) / CD Player (Recorder)
- : Digital Video Recorder
- : TV

Operating the Main Remote Control Unit

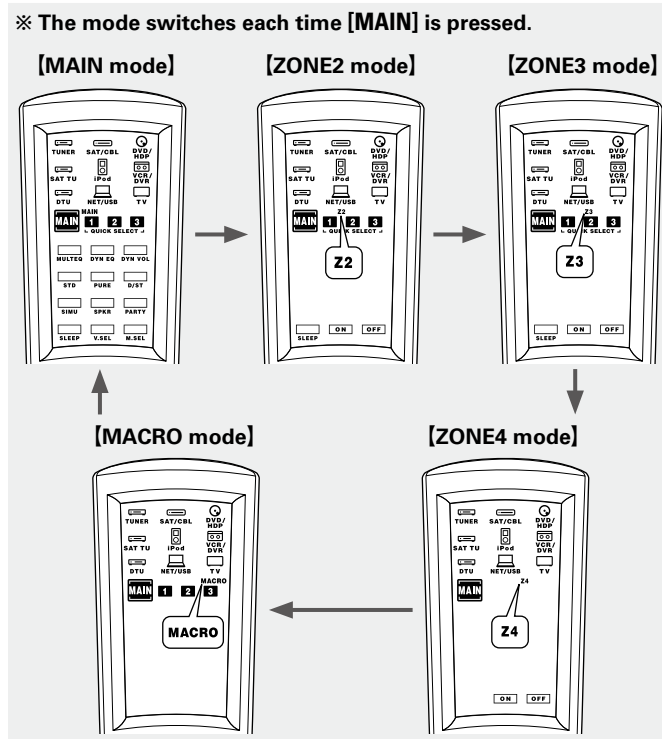
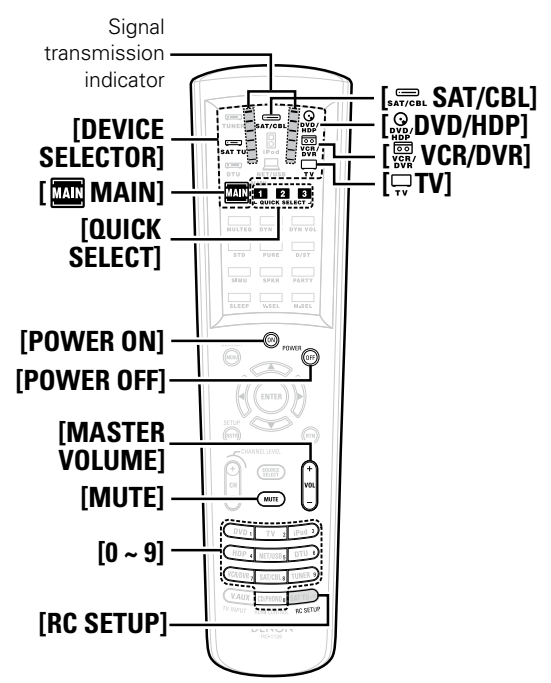

2 Operate the component.

※ For details, refer to the component's operating instructions.



- In ZONE2, ZONE3 and ZONE4 modes, you can switch the MAIN ZONE power on or off by pressing [POWER ON] or [POWER OFF].
- [QUICK SELECT], [MUTE] and [MASTER VOLUME] can also be operated when the device selected is something other than [MAIN]. In this case, the zone you used last can be operated. Check using the zone indicator.

Presetting

The included main remote control unit can be preset to operate devices of various brands.

- 1** Press [DVD/HDP], [VCR/DVR], [TV] or [SAT/CABLE] for the device you want to preset.
 - 2** Press and hold in [RC SETUP] for at least 3 seconds. The signal transmission indicator flashes twice.
 - 3** Press [0 ~ 9] and input the 5-digit number of the brand of the component to be preset. The numbers are shown in the Preset Code Table (End of this manual).
When the code is registered, the signal transmission indicator flashes twice.
When the preset code is transmitted, the mode indicator for the component to which that code belongs flashes.
- ※ The input mode is canceled if no button is operated for 10 seconds.



- Some brands have more than one preset code. If the component does not operate, try inputting a different code.
- Depending on the model and year of manufacture of your equipment, some buttons may not operate. In such cases we recommend using the learning function. (page 104 "Learning Function")

Operating Preset Components

1 Press [DEVICE SELECTOR] for the component to be operated.
The mode indicator of the device to be operated flashes.

2 Operate the component.

* For details, refer to the component's operating instructions.

Blu-ray Disc Player / HD DVD Player / DVD Player / DVD Recorder

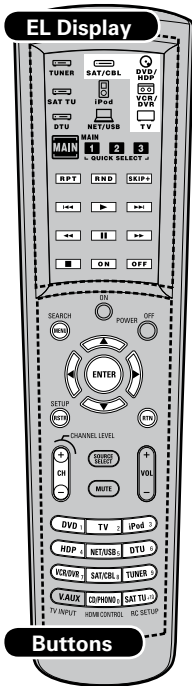

EL Display	
Device select button	DVD/HDP (SAT/CBL VCR/DVR TV) *1
RPT	Repeat
RND	Random
SKIP+	Disc Skip (For charger-compatible devices)
⏮⏭⏪⏩	Auto search (cue)
▶	Playback
⏮⏭⏪⏩	Manual search (fast-reverse/fast-forward)
⏸	Still/Pause
■	Stop
ON	Power on *2
OFF	Power off *2
Buttons	
MENU/SEARCH	(Popup) Menu
△▽◀▶	Cursor
ENTER	Enter
SETUP/RSTR	Setup
RTN	Return
CH +, -	Switch channels (up/down)
0 ~ 9, +10	Select title or chapter or channel selection

* 1: Preset registration is also possible for the Device Select buttons in ().

* 2: This may power some devices ON/OFF.

CD Player / CD Recorder

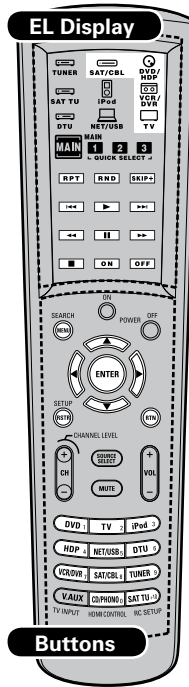

EL Display	
Device select button	DVD/HDP (SAT/CBL VCR/DVR TV) *1
RPT	Repeat
RND	Random
SKIP+	Disc Skip (For charger-compatible devices)
⏮⏭⏪⏩	Auto search (cue)
▶	Playback
⏮⏭⏪⏩	Manual search (fast-reverse/fast-forward)
⏸	Pause
■	Stop
ON	Power on *2
OFF	Power off *2
Buttons	
MENU/SEARCH	Amp menu
△▽◀▶	Amp cursor
ENTER	Amp enter
SETUP/RSTR	RESTORER
RTN	Amp return
0 ~ 9, +10	Track Selection

* 1: Preset registration is also possible for the Device Select buttons in ().

* 2: This may power some devices ON/OFF.

Digital Video Recorder / Video cassette Recorder / Cassette Deck

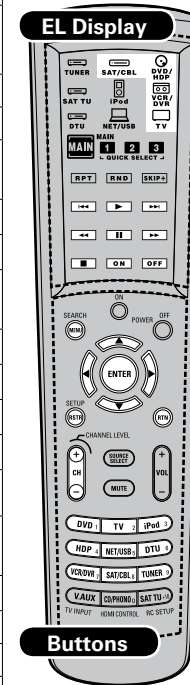

EL Display	
Device select button	VCR/DVR (SAT/CBL DVD/HDP TV) *1
⏮⏭⏪⏩	Auto search (cue)
▶	Playback
⏮⏭⏪⏩	Manual search (fast-reverse/fast-forward)
⏸	Still/Pause
■	Stop
ON	Power on *2
OFF	Power off *2
Buttons	
MENU/SEARCH	Menu/guide
△▽◀▶	Cursor
ENTER	Enter
SETUP/RSTR	Setup
RTN	Return
CH +, -	Switch channels (up/down)
1 ~ 9	Channel Selection

* 1: Preset registration is also possible for the Device Select buttons in ().

* 2: This may power some devices ON/OFF.

Operating the Main Remote Control Unit

TV

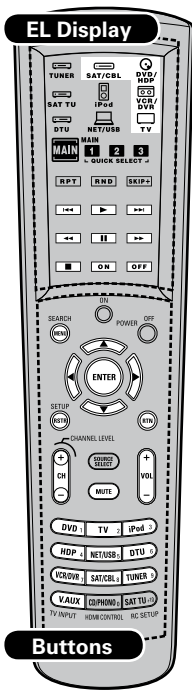

EL Display	
Device select button	() * 1
	Auto search (cue)
	Playback
	Manual search (fast-reverse/fast-forward)
	Still/Pause
	Stop
ON	Power on * 2
OFF	Power off * 2
Buttons	
MENU/SEARCH	Menu/guide
	Cursor
ENTER	Enter
SETUP/RSTR	RESTORER
RTN	Return
CH +, -	Switch channels (up/down)
MUTE	TV mute
VOL +, -	TV Volume +, -
1 ~ 9	Channel Selection
TV INPUT	TV inputs

* 1: Preset registration is also possible for the Device Select buttons in ().
* 2: This may power some devices ON/OFF.

Set top box for Satellite / Cable / IP TV / HD TV

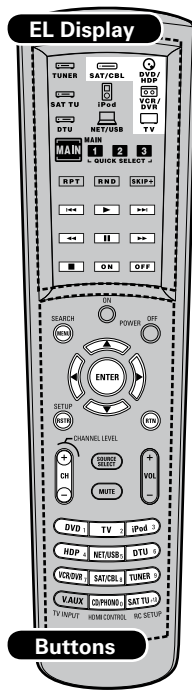

EL Display	
Device select button	() * 1
	Auto search (cue)
	Playback
	Manual search (fast-reverse/fast-forward)
	Still/Pause
	Stop
ON	Power on * 2
OFF	Power off * 2
Buttons	
MENU/SEARCH	Menu
	Cursor
ENTER	Enter
SETUP/RSTR	Guide
RTN	Return
CH +, -	Switch channels (up/down)
0 ~ 9, +10	Channel Selection

* 1: Preset registration is also possible for the Device Select buttons in ().
* 2: This may power some devices ON/OFF.

iPod

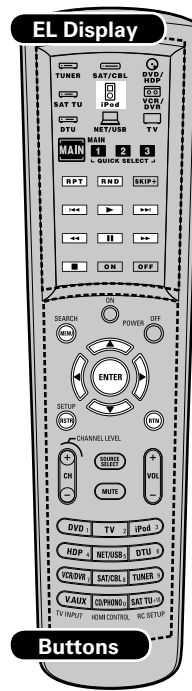

EL Display	
Device select button	
RPT	1-track/All-track repeat play
RND	1-track/album shuffle play
	Auto search (cue)
	Playback
	Manual search (fast-reverse/fast-forward)
	Still/Pause
	Stop
Buttons	
MENU/SEARCH (Press and release)	Page search mode
(Press and hold)	Browse / Remote mode switching
	Cursor / Manual Search (Δ▽)
ENTER	Enter
SETUP/RSTR	RESTORER
RTN	Return

Tuner (FM/AM)

NET/USB

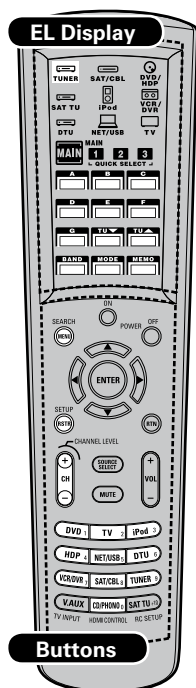

EL Display	
Device select button	TUNER
A ~ G	Preset memory block selection
TU ▲▼	Tuning +/-
BAND	AM/FM switching
MODE	Switch search modes
MEMO	Preset memory registration
Buttons	
MENU/SEARCH	Direct Frequency tuning / RDS Search
SETUP/RSTR	RESTORER
CH +/-	Preset channel selection
0 ~ 9	Preset channel selection (1 ~ 8) / Direct frequency tuning (0 ~ 9)

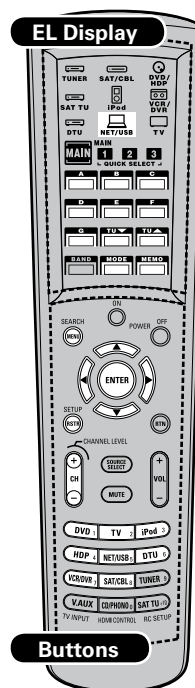

EL Display	
Device select button	NET/USB
A ~ G	Preset memory block selection
TU ▲▼	Switching picture
MEMO	Preset memory registration
Buttons	
MENU/SEARCH	Page Search / Character Search
△▼◀▶	Cursor
ENTER	Enter
SETUP/RSTR	RESTORER
CH +/-	Preset channel selection
1 ~ 8	Preset channel selection (1 ~ 8)

Operating the Main Remote Control Unit

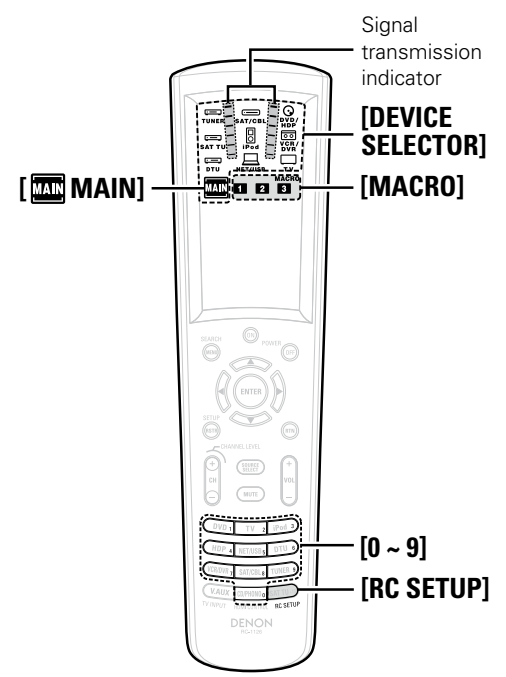
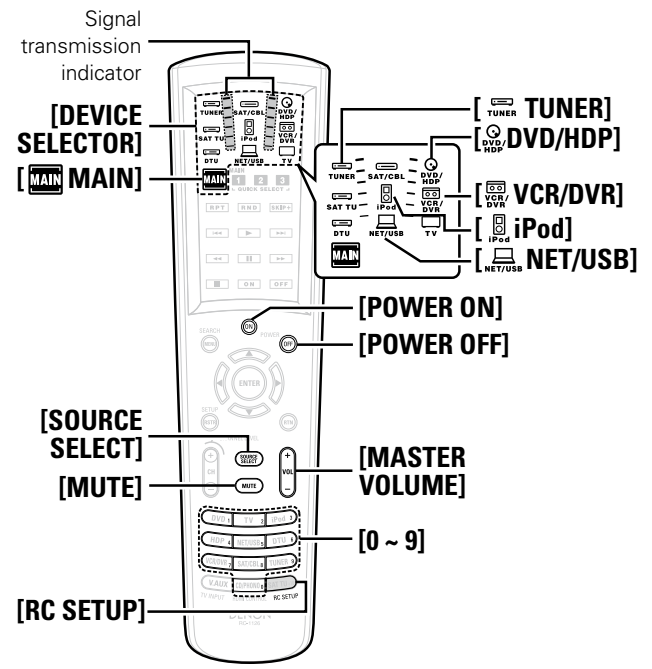

Setting the Remote ID

When using multiple DENON AV receivers in the same room, make this setting so that only the desired AV receiver operates.

- 1 Press [MAIN] to light the "MAIN" zone indicator.
- 2 Press and hold in [RC SETUP] for at least 3 seconds. The signal transmission indicator flashes twice.
- 3 Refer to the table at the right, and use [0 ~ 9] to input the 5-digit number corresponding to the remote ID to be changed. The signal transmission indicator flashes twice.
- 4 Press [TUNER], [iPod] or [NET/USB] to select the mode to be set.
- 5 Repeat steps 2 to 4 to set the remote IDs for all modes.

Remote ID	DEVICE SELECTOR			
	MAIN	TUNER	iPod	NET/USB
1 (Default)	81001	62863	72815	62865
2	82001	62275	72816	62837
3	83001	62276	72817	62838
4	84001	62277	72818	62839

- NOTE**
- When changing a setting, be sure to set the same remote ID as the AVR-4810's (page 55).
 - When changing the MAIN mode's remote ID, also change "TUNER", "iPod" and "NET/USB" remote ID at the same time.

Learning Function

If your AV devices are of a brand other than DENON or if they cannot be operated with the preset memory function, their remote control signals can be transferred to stored in the AVR-4810's main remote control unit.

- 1 Press and hold in [RC SETUP] for at least 3 seconds. The signal transmission indicator flashes twice.
 - 2 Press [9], [7] and [5], in that order. The signal transmission indicator flashes twice and the learning mode is set.
 - 3 Press [DEVICE SELECTOR] for the device you want to set
 - 4 Press the button to be set. The main remote control unit's display turns off.
- ※ If a button that cannot be learned is pressed, the signal transmission indicator lights but the signal is not learned.
- 5 Point the main remote control units directly at each other and press and hold the button on the other device's remote control unit that you want to learn. Once learning is completed normally, the display lights and the signal transmission indicator flashes twice.

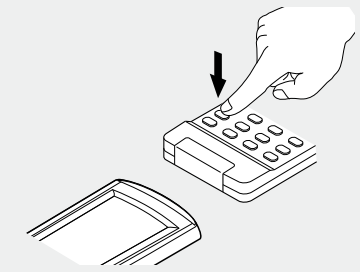

- ※ If you want to learn other buttons, repeat steps 4 and 5.
- ※ The mode can be switched by pressing [DEVICE SELECTOR].
- ※ The signal transmission indicator lights once for a long time if learning was not possible

- 6 Press and hold in [RC SETUP] for at least 3 seconds. The signal transmission indicator flashes twice and the setting is completed.



- With some remote control units, the signals cannot be learned or the device will not operate properly even when the signals have been learned. In this case, use the device's own remote control unit.
- Learned buttons have priority over the preset memory. If you no longer need the learned setting, reset the learning function (page 107).

NOTE

- **[POWER ON]**, **[POWER OFF]** and **[SOURCE SELECT]** cannot be learned.
- Do not learn any remote control signals at **[RC SETUP]**.
- The MAIN, ZONE2, ZONE3, ZONE4 and MACRO modes cannot be learned.
- Codes cannot be learned at **[MASTER VOLUME]** or **[MUTE]** when the main remote control unit is set to "TUNER", "NET/USB" or "iPod".

MACRO Function

This function lets you register a series of operations at a single button.

For example, the amplifier can be turned on, the input source selected, the monitor's power turned on, the source device's power turned on and the play mode set all by pressing a single button.

Up to 32 signals each can be registered at **[MACRO] (1 ~ 3)**.

Registering

- 1 Press and hold in [RC SETUP] for at least 3 seconds.**
The signal transmission indicator flashes twice.
- 2 Press [9], [7] and [8], in that order.**
The signal transmission indicator flashes twice and the system call registration mode is set.
- 3 Press [MACRO] (1 ~ 3) at which you want to register the signals.**
- 4 Press the buttons you want to register in the same sequence as the operations you want to perform.**
The signal transmission indicator lights when a button is pressed.
Example : Press **[POWER ON]**.
↓
Press **[DEVICE SELECTOR] – [DVD/HDP]**.
↓
Press **[▶]**.

※ The mode can be switched by pressing **[DEVICE SELECTOR]**.
※ Perform the registration procedure for all the buttons you want to register.
- 5 Press and hold in [RC SETUP] for at least 3 seconds.**
The signal transmission indicator flashes twice and the setting is completed.

NOTE

Registration is not possible in ZONE2, ZONE3, ZONE4 and MACRO modes.

Calling out

- 1 Press [MAIN], to select "MACRO".**
- 2 Press [MACRO] (1 ~ 3) at which the signals were registered.**
The registered signals are transmitted in the registered sequence.

Operating the Main Remote Control Unit

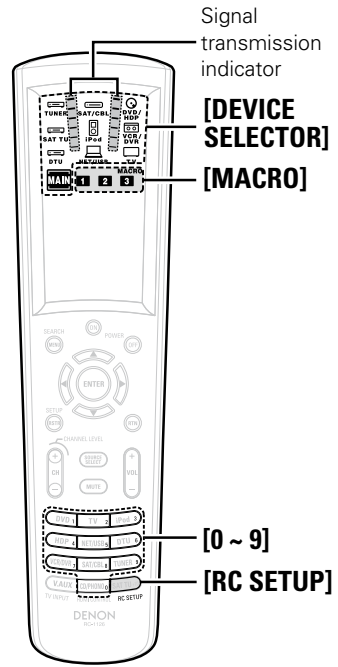
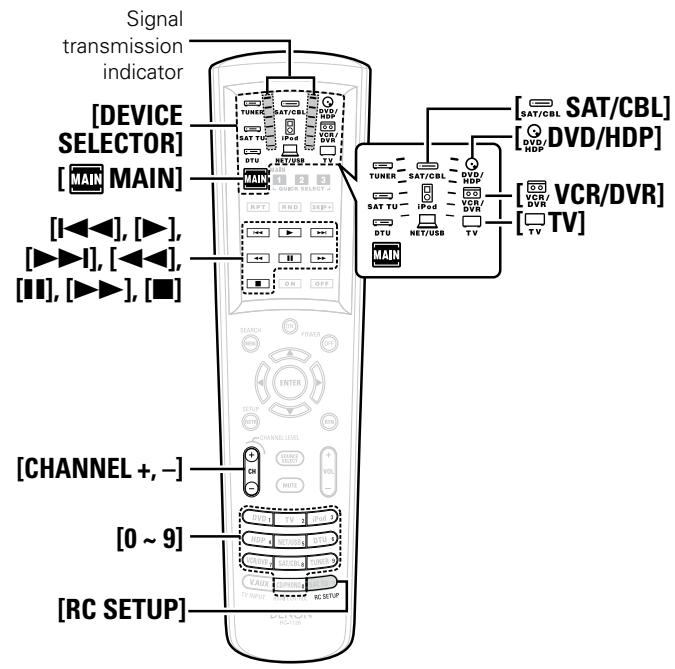

Punch Through Function

DVD/HDP (including BD and CD) or VCR/DVR mode buttons can be stored at unused TV or SAT/CBL mode buttons. For example, when DVD mode buttons are assigned to the TV mode, the DVD mode operations can be performed while in the TV mode.

- 1 Press and hold in [RC SETUP] for at least 3 seconds.**
The signal transmission indicator flashes twice.
- 2 Press [9], [8] and [4], in that order.**
The signal transmission indicator flashes twice and the punch through setting mode is set.
- 3 Press [DEVICE SELECTOR] for the device you want to punch through ([DVD/HDP] or [VCR/DVR]).**
- 4 Press the button you want to punch through ([>>], [||], [<<<], [>>>], [<<<|], [>>>|] or [||]).**
Each time the button is pressed, the signal transmission indicator flashes once.
- 5 Press [DEVICE SELECTOR] for the device you want to punch through ([TV] or [SAT/CBL]).**
- 6 Press and hold in [RC SETUP] for at least 3 seconds.**
The signal transmission indicator flashes twice and the setting is completed.

NOTE

The Punch Through function can only be registered for either TV or SAT/CBL. DVD/HDP punch through may be automatically assigned, depending on the equipment that has been preset to TV and SAT/CBL.

Setting the Time the Backlight Stays Lit

- 1 Press and hold in [RC SETUP] for at least 3 seconds.**
The signal transmission indicator flashes twice.
- 2 Press [9], [7] and [3], in that order.**
The signal transmission indicator flashes twice and the backlight on time setting mode is set.
- 3 Set the light on time.**
The signal transmission indicator flashes twice.
[Settable times] : [1] : 5 sec.
[2] : 10 sec. (Default)
[3] : 15 sec.
[4] : 20 sec.
[5] : 25 sec.

Adjusting the Backlight's Brightness

The display's brightness can be adjusted in 5 steps. (Default: Step 5)

- 1 Press and hold in [RC SETUP] for at least 3 seconds.**
The signal transmission indicator flashes twice.
- 2 Press [CHANNEL +] or [CHANNEL -].**
The display gets one step brighter when [CHANNEL +] is pressed.
The display gets one step darker when [CHANNEL -] is pressed.
- 3 Press [RC SETUP] to complete the setting.**

Specifying the Zone Used with the Main Remote Control Unit

When the **[MAIN]** Device Select button is pressed, only the set zone can be operated with the main remote control unit.

1 Press **[MAIN]** to light the “MAIN” zone indicator.

2 Press and hold in **[RC SETUP]** for at least 3 seconds.
The signal transmission indicator flashes twice.

3 Press **[9]**, **[9]** and **[9]**, in that order.
The signal transmission indicator flashes twice and the backlight on time setting mode is set.

4 Press **[1 ~ 4]** to set.
The signal transmission indicator flashes twice.

[Settable items]

[1] : When only using “MAIN” / “MACRO”

[2] : When using “MAIN” / “Z2” / “MACRO”

[3] : When using “MAIN” / “Z2” / “Z3” / “MACRO”

[4] : When using “MAIN” / “Z2” / “Z3” / “Z4” / “MACRO”
(Default)

Resetting the Main Remote Control Unit

Learning Function

❑ Resetting Button by Button

1 Press and hold in **[RC SETUP]** for at least 3 seconds.
The signal transmission indicator flashes twice.

2 Press **[9]**, **[7]** and **[6]**, in that order.
The signal transmission indicator flashes twice.

3 Press the button you want to reset twice.
The signal transmission indicator flashes twice.

❑ Resetting by Device Mode

1 Press and hold in **[RC SETUP]** for at least 3 seconds.
The signal transmission indicator flashes twice.

2 Press **[9]**, **[7]** and **[6]**, in that order.
The signal transmission indicator flashes twice.

3 Press **[DEVICE SELECTOR]** for the device you want to reset twice.
The signal transmission indicator flashes twice.

MACRO Function

1 Press and hold in **[RC SETUP]** for at least 3 seconds.
The signal transmission indicator flashes twice.

2 Press **[9]**, **[7]** and **[8]**, in that order.
The signal transmission indicator flashes twice.

3 Press **[MACRO]** (1 ~ 3) you want to reset.

4 Press and hold in **[RC SETUP]** for at least 3 seconds.
The signal transmission indicator flashes twice.

Punch-Through Function

1 Press and hold in **[RC SETUP]** for at least 3 seconds.
The signal transmission indicator flashes twice.

2 Press **[9]**, **[8]** and **[4]**, in that order.
The signal transmission indicator flashes twice.

3 Press and hold in **[RC SETUP]** for at least 3 seconds.
The signal transmission indicator flashes twice.

All Settings

1 Press and hold in **[RC SETUP]** for at least 3 seconds.
The signal transmission indicator flashes twice.

2 Press **[9]**, **[8]** and **[1]**, in that order.
The signal transmission indicator flashes 4 times.
All the settings are restored to their defaults.

Operating the Sub Remote Control Unit

- The sub remote control unit is equipped with frequently used buttons, so it can be used for simple remote control unit operations.
- The sub remote control unit can also be used for multi-zone, so you can use it to control the AVR-4810 from other rooms.
- The operations listed below can be performed with the sub remote control unit.
 - Switching the input source
 - Adjusting the volume
 - TUNER and iPod operations
 - NET/USB direct play
 - GUI menu and ZONE2 on-screen display operations
 - Zone power on/off
- It is not possible to operate devices other than the amplifier.

 In ZONE4 mode, only the [ZONE OFF], [ZONE ON] and [INPUT SOURCE SELECT] buttons can be operated.

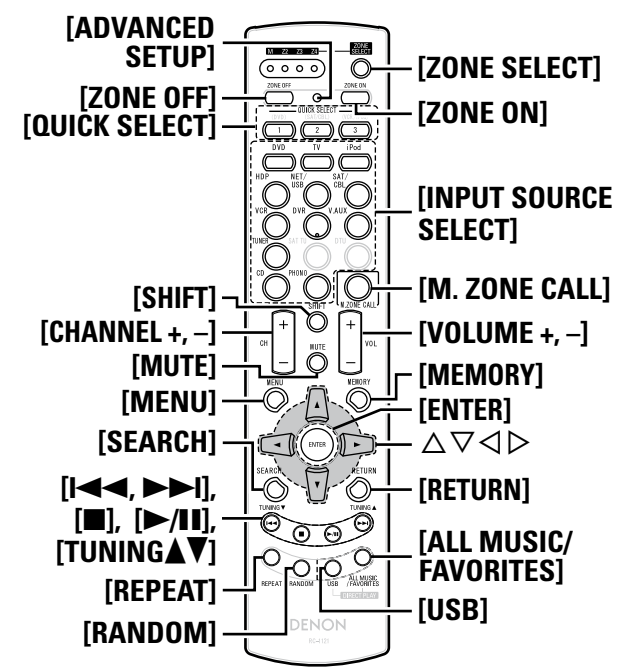

Functions of Buttons by Component

Device operated	TUNER				NET/USB				iPod			
	M	Z2	Z3	Z4	M	Z2	Z3	Z4	M	Z2	Z3	Z4
Zone selection												
ZONE SELECT	Zone operation mode selection											
ZONE OFF	Power turned off (※1)											
ZONE ON	Power turned on (※1)											
INPUT SOURCE SELECT	Input source selection (※2)											
QUICK SELECT	Quick select function											
CHANNEL + / -	Preset channel selection	-	-	-	Preset channel selection	-	-	-	-	-	-	-
SHIFT	Preset channel memory block selection	-	-	-	Preset channel memory block selection	-	-	-	-	-	-	-
VOLUME + / -	Adjustment of volume (※1)	-	-	-	Adjustment of volume (※1)	-	-	-	Adjustment of volume (※1)	-	-	-
MUTE	Muting (※1)	-	-	-	Muting (※1)	-	-	-	Muting (※1)	-	-	-
MENU	Selected zone menu	-	-	-	Selected zone menu	-	-	-	Selected zone menu	-	-	-
MEMORY	Preset memory registration	-	-	-	Preset memory registration	-	-	-	-	-	-	-
△ ▽ ◀ ▶	-	-	-	-	Cursor	-	-	-	Cursor	-	-	-
ENTER	-	-	-	-	Enter	-	-	-	Enter	-	-	-
SEARCH	RDS search	-	-	-	Page forward screen / Character search	-	-	-	Page forward screen / Browse/Remote mode switching (press and hold)	-	-	-
RETURN	-	-	-	-	Return	-	-	-	Return	-	-	-
◀▶▶▶, TUNING ▲ ▼	Tuning	-	-	-	Track search	-	-	-	Track search	-	-	-
■	-	-	-	-	Stop	-	-	-	Stop	-	-	-
▶ 	-	-	-	-	Play/pause	-	-	-	Play/pause	-	-	-
REPEAT	-	-	-	-	1-track/All-track repeat play	-	-	-	1-track/All-track repeat play	-	-	-
RANDOM	-	-	-	-	1-track random play	-	-	-	1-track/album shuffle play	-	-	-
USB	-	-	-	-	※3	-	-	-	-	-	-	-
ALL MUSIC * (Music server only)	-	-	-	-	※4	-	-	-	-	-	-	-
FAVORITES *	-	-	-	-	※5	-	-	-	-	-	-	-

- ※1: Affects the currently selected zone.
- ※2: In ZONE4, only input sources to which NET/USB and digital input have been assigned can be selected.
- ※3: The input source switches to "NET/USB" and the files on the USB memory device are played.
- ※4: The input source switches to "NET/USB" and the files in "All Music" on the music server are played.
- ※5: The input source switches to "NET/USB" and the files in "Favorites" are played.
- *: Whether "All Music" or "Favorites" is selected depends on the "Direct Play" setting (page 62).

DIRECT PLAY button

- Playback is possible in the mode selected at GUI menu "Direct Play".
- FAVORITES:** Playback starts from the first track registered in the favorites.
- ALL MUSIC:** Playback starts from the first track registered in the "All Music" folder.
- When [USB] is pressed, playback starts from the first track on the USB memory device.

NOTE

When the music server is stopped or restarted, it may no longer be possible to play tracks stored in the favorites.

Switching Zones

Use this procedure to select the zone to be operated by the sub remote control unit.

1 Press [ZONE SELECT].

The currently selected multi-zone indicator lights.

2 While the multi-zone indicator is light, press [ZONE SELECT] to select the zone to be operated.

The currently selected multi-zone indicator lights.

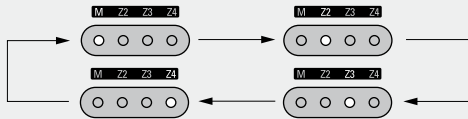

Switching the Multi-zone Input Source to the Same Input Source as Used in the MAIN ZONE

This function is convenient for example when you want to listen to the same song as the one playing in the MAIN ZONE while in a different zone.

1 Press [ZONE SELECT] and set to ZONE2, ZONE3 or ZONE4.

The currently selected multi-zone indicator lights.

2 Press [M.ZONE CALL] on the sub remote control unit.

The multi-zone input source switches to the MAIN ZONE's input source.

NOTE

- This cannot be used for the MAIN ZONE.
- When [M.ZONE CALL] is pressed while the multi-zone power is off, the multi-zone power turns on and the input source switches to the MAIN ZONE's input source.

Setting the Zone for Which the Sub Remote Control Unit is Used (ZONE SELECT LOCK Mode)

We recommend always using the sub remote control unit for the same room. When this is done, the unit can be set so that the zone does not switch when buttons are operated.

1 Use the tip of a pen to press [ADVANCED SETUP].

All the multi-zone indicators light.

2 Select the multi-zone to be set.

The selected multi-zone indicator lights.

- ① To set to "MAIN ZONE" : Press [REPEAT].
- ② To set to "ZONE2" : Press [RANDOM].
- ③ To set to "ZONE3" : Press [USB].
- ④ To set to "ZONE4" : Press [ALL MUSIC/FAVORITES].

3 Use the tip of a pen to press [ADVANCED SETUP].

The multi-zone indicator turns off.

To Cancel

1 Use the tip of a pen to press [ADVANCED SETUP].

The currently selected multi-zone indicator lights.

2 Press [ZONE SELECT].

All the multi-zone indicators light.

3 Use the tip of a pen to press [ADVANCED SETUP].

The multi-zone indicator turns off.

Setting the Remote ID

When using multiple DENON AV receivers in the same room, make this setting so that no AV receiver other than the desired one operates.

1 While pressing [MENU], press [ADVANCED SETUP] with the tip of a pen.

The multi-zone indicator corresponding to the currently selected remote ID flashes.

2 Select the remote ID to be set.

- ① To set to 1 : Press [REPEAT].
The "M" indicator flashes.
- ② To set to 2 : Press [RANDOM].
The "Z2" indicator flashes.
- ③ To set to 3 : Press [USB].
The "Z3" indicator flashes.
- ④ To set to 4 : Press [ALL MUSIC/FAVORITES].
The "Z4" indicator flashes.

3 While pressing [MENU], press [ADVANCED SETUP] with the tip of a pen.

The multi-zone indicator turns off.

NOTE

When changing a setting, be sure to set the same remote ID as the AVR-4810's (page 55).

Resetting the Settings

While pressing [ZONE OFF], press [ADVANCED SETUP] with the tip of a pen.

All the multi-zone indicators flash 4 times, then all the settings are restored to their defaults.

Other Information

Explanation of Terms

The AVR-4810 is equipped with a digital signal processing circuit that lets you play program sources in the surround mode to achieve the same sense of presence as in a movie theater.

Dolby Surround

Dolby Digital

Dolby Digital is a multi-channel digital signal format developed by Dolby Laboratories.

A total of 5.1-channels are played: 3 front channels ("FL", "FR" and "C"), 2 surround channels ("SL" and "SR") and the "LFE" channel for low frequencies.

Because of this, there is no crosstalk between channels and a realistic sound field with a "three-dimensional" feeling (sense of distance, movement and positioning) is achieved.

A real, overpowering sense of presence is achieved when playing movie sources in AV rooms as well.

Dolby Digital Plus

Dolby Digital Plus is an improved Dolby Digital signal format that is compatible with up to 7.1-channels of discrete digital sound and also improves sound quality thanks to extra data bit rate performance. It is upwardly compatible with conventional Dolby Digital, so it offers greater flexibility in response to the source signal and the conditions of the playback equipment.

Dolby TrueHD

Dolby TrueHD is a high definition audio technology developed by Dolby Laboratories, using lossless coding technology to faithfully reproduce the sound of the studio master.

This format is compatible with a maximum sampling frequency of 96 kHz and up to 7.1-channels, so it is used for applications particularly prioritizing sound quality.

Dolby Pro Logic II

Dolby Pro Logic II is a matrix decoding technology developed by Dolby Laboratories.

Regular music such as that on CDs is encoded into 5-channels to achieve an excellent surround effect.

The surround channel signals are converted into stereo and full band signals (with a frequency response of 20 Hz to 20 kHz or greater) to create a "three-dimensional" sound image offering a rich sense of presence for all stereo sources.

Dolby Pro Logic IIx

Dolby Pro Logic IIx is a further improved version of the Dolby Pro Logic II matrix decoding technology.

Audio signals recorded in 2-channels are decoded to achieve a natural sound with up to 7.1-channels.

There are 3 modes: "Music" suited for playing music, "Cinema" suited for playing movies, and "Game" which is optimized for playing games.

Dolby Digital EX

Dolby Digital EX is a 6.1-channel surround format proposed by Dolby Laboratories that allows users to enjoy in their homes the "DOLBY DIGITAL SURROUND EX" audio format jointly developed by Dolby Laboratories and Lucas Films.

The 6.1 channels of sound, including surround back channels, provide improved sound positioning and expression of space.

Dolby Pro Logic IIz

Dolby Pro Logic IIz introduces a new dimension to Home Entertainment through the addition of a pair of front height channels. Compatible with stereo, 5.1 and 7.1 content, Dolby Pro Logic IIz provides enhanced spaciousness, depth and dimension to movies, concert video and video game playback while maintaining the full integrity of the source mix.

Dolby Pro Logic IIz identifies and decodes spatial cues that occur naturally in all content, directing this information to the front height channels, complementing the performance of left and right surround sound speakers. Content that is encoded with Dolby Pro Logic IIz height channel information can be even more revealing, with perceptually discrete height channel information bringing an exciting new dimension to home entertainment.

Dolby Pro Logic IIz, with front height channels is also an ideal alternative for households that cannot support the placement of back surround speakers of a typical 7.1 channel system but may have bookshelf space available to support the addition of height speakers.

Manufactured under license from Dolby Laboratories. "Dolby", "Pro Logic" and the double-D symbol are trademarks of Dolby Laboratories.

DTS Surround

DTS Digital Surround

DTS Digital Surround is the standard digital surround format of DTS, Inc., compatible with a sampling frequency of 44.1 or 48 kHz and up to 5.1-channels of digital discrete surround sound.

DTS-HD High Resolution Audio

DTS-HD High Resolution Audio is an improved version of the conventional DTS, DTS-ES and DTS 96/24 signals formats, compatible with sampling frequencies of 96 or 48 kHz and up to 7.1-channels of discrete digital sound. High data bit rate performance provides high quality sound. This format is fully compatible with conventional products, including conventional DTS digital surround 5.1-channel data.

DTS-HD Master Audio

DTS-HD Master Audio is DTS, Inc.'s lossless audio format compatible with up to 96 kHz/7.1-channels. The lossless audio coding technology faithfully reproduces the sound of the studio master. It is fully compatible with conventional products, including conventional DTS digital surround 5.1-channel data.

DTS-ES™ Discrete 6.1

DTS-ES™ Discrete 6.1 is a 6.1-channel discrete digital audio format adding a surround back (SB) channel to the DTS digital surround sound.

Decoding of conventional 5.1-channel audio signals is also possible according to the decoder.

DTS-ES™ Matrix 6.1

DTS-ES™ Matrix 6.1 is a 6.1-channel discrete digital audio format inserting a surround back (SB) channel to the DTS digital surround sound through matrix encoding. Decoding of conventional 5.1-channel audio signals is also possible according to the decoder.

DTS NEO:6™ Surround

DTS NEO:6™ is a matrix decoding technology for achieving 6.1-channel surround playback with 2-channel sources. It includes "DTS NEO:6 Cinema" suited for playing movies and "DTS NEO:6 Music" suited for playing music.

DTS 96/24

DTS 96/24 is a digital audio format enabling high sound quality playback in 5.1-channels with a sampling frequency of 96 kHz and 24 bit quantization on DVD-Video.

DTS Express

DTS Express is an audio format supporting low bit rates (max. 5.1-channels, 24 to 256 kbps).

Manufactured under license under U.S. Patent #'s: 5,451,942; 5,956,674; 5,974,380; 5,978,762; 6,226,616; 6,487,535; 7,212,872; 7,333,929; 7,392,195; 7,272,567 & other U.S. and worldwide patents issued & pending. DTS is a registered trademark and the DTS logos, Symbol, DTS-HD and DTS-HD Master Audio are trademarks of DTS, Inc. © 1996-2008 DTS, Inc. All Rights Reserved.

Audyssey

Audyssey MultEQ® XT

Audyssey MultEQ XT is a room equalization solution that calibrates any audio system so that it can achieve optimum performance for every listener in a large listening area. Based on several room measurements, MultEQ XT calculates an equalization solution that corrects for both time and frequency response problems in the listening area and also performs a fully automated surround system setup.

Audyssey Dynamic EQ™

Audyssey Dynamic EQ solves the problem of deteriorating sound quality as volume is decreased by taking into account human perception and room acoustics. Audyssey Dynamic EQ works in tandem with Audyssey MultEQ XT to provide well-balanced sound for every listener at any volume level.

Audyssey Dynamic Volume™

Audyssey Dynamic Volume solves the problem of large variations in volume level between television programs, commercials, and between the soft and loud passages of movies.

Audyssey Dynamic EQ is integrated into Dynamic Volume so that as the playback volume is adjusted automatically, the perceived bass response, tonal balance, surround impression, and dialog clarity remain the same.

Audyssey Dynamic Surround Expansion™ (DSX)

Realistic reproduction of sound relies on the ability of audio systems to match human hearing performance. Three key requirements are: (1) frequency response; (2) dynamic range; and (3) accurate spatial reproduction. The requirements for frequency response have already been surpassed with sampling rates that exceed human hearing. The dynamic range limits of human perception have also been met with current digital audio systems operating capable of signal to noise ratios that approach 120 dB. Accurate spatial sound rendering, however, has not yet reached the limits of perception as human perception relies on the combination of sounds arriving from many more directions than what 5.1 surround sound systems provide. Audyssey DSX technology was developed to overcome the spatial sound rendering limitations faced by 5.1 surround sound formats.

The ITU 5.1 channel standard recommends three front loudspeakers and two rear loudspeakers. The Left (L) and Right (R) front loudspeakers should be placed at $\pm 30^\circ$ relative to the central listening position. The Center (C) loudspeaker should be at 0° and the surround loudspeakers (SL, SR) should be placed between 100° and 120° . All loudspeakers must be equidistant from the center listening position or compensated with time delay if that is not possible. A separate low-frequency effects (LFE) channel is used to reproduce additional bass content from the subwoofer.

There are certain things that 5.1 surround sound systems do well compared to 2-channel stereo. For example, it is possible to move sounds across the front seamlessly. It is also possible to create ambience behind the listener. But 5.1 channel surround systems do not provide enough channels from which to render the required reflected sound components for a seamless and enveloping soundstage. Unfortunately, the additional two back surround channels in 7.1 systems are not in the right place to provide a significant perceptual improvement.

Adding more channels to a surround system is not for special effects. Accurate spatial sound reproduction requires rendering of directional sound cues and non-directional ambient cues. Reflections arriving after the direct sound play a critical role in the perception of soundstage width and depth. To have the most impact, additional surround channels should be used to control the direction, time of arrival, and frequency response of the reflected sound to render an expanded soundstage that reproduces sound with better localization and envelopment than what 5.1 systems provide.

Explanation of Terms

Research in the perception of auditory source width has shown that there are strong preferences in the direction of reflected sound and the perception of soundstage width and spaciousness. The single most important direction of side-wall reflections is $\pm 60^\circ$. DSX provides a pair of Wide channels (LW and RW) at $\pm 60^\circ$ with appropriate frequency response and perceptual processing to match the requirements of human hearing. In fact, the Wide channels are much more critical in the presentation of a realistic soundstage than then Back Surround channels found in traditional 7.1 systems. A more enveloping 7.1 channel system is one in which Wide speakers are used instead of Back Surround speakers. Adding surround channels behind the listener has a very small impact compared to the increase in envelopment and soundstage width that the front wide channels will provide.

After side reflections, the next most important acoustical and perceptual cues come from reflections above the front stage. DSX provides a pair of Height channels (LH and RH) at a $\pm 45^\circ$ azimuth angle and elevated to a 45° angle in the median plane.

In addition to creating new Wide and Height channels, DSX also provides Surround Processing to enhance the envelopment of the Surround and Back Surround channels (if present). DSX Surround Processing processes the standard surround signals in the time and frequency domains to improve the perceived sense of envelopment and blending with the other speakers in the surround system.

Audyssey Dynamic Surround Expansion is a scalable system that can adapt to the practical needs of the user. The first level of surround stage enhancement comes from adding the Wide channels. The second level comes from adding the Height channels. If it is practical to have both Wides and Heights then the surround performance will be further enhanced. DSX automatically reconfigures its processing to optimize surround rendering over any number of available speakers beyond 5.1.



Manufactured under license from Audyssey Laboratories. U.S. and foreign patents pending. Audyssey MultEQ[®] XT is a registered trademark of Audyssey Laboratories. Audyssey Dynamic EQ[™] is a trademark of Audyssey Laboratories. Audyssey Dynamic Volume[™] is a trademark of Audyssey Laboratories. Audyssey Dynamic Surround Expansion[™] is a trademark of Audyssey Laboratories.

HDCD[®]

HDCD[®] is an encoding/decoding technology that greatly reduces the distortion that occurs upon digital recording while maintaining compatibility with the conventional CD format, thus expanding the dynamic range and achieving a high resolution. Conventional CDs and HDCD compatible CDs are identified automatically to select the optimum digital processing.

HDCD[®], HDCD[®], High Definition Compatible Digital[®] and Microsoft[®] are either registered trademarks or trademarks of Microsoft Corporation, Inc. in the United States and/or other countries. HDCD system manufactured under license from Microsoft Corporation, Inc. This product is covered by one or more of the following: In the USA: 5,479,168, 5,638,074, 5,640,161, 5,808,574, 5,838,274, 5,854,600, 5,864,311, 5,872,531, and in Australia: 669114. Other patents pending.

DENON LINK

DENON LINK is a unique digital, balanced transfer type interface developed by DENON. It offers high speed, high quality transfer of digital audio data with low signal loss. It can be used together with DENON DVD player equipped with a special DENON LINK connector using a single cable to enable playback with high sound quality. It allows digital transfer of the 192 kHz/24 bit 2-channel digital signals of DVD-Audio discs, PCM multi-channel signals, etc. Full-spec digital transfer of the audio contents of Super Audio CD is possible by connecting a player equipped for DENON LINK 3rd Edition. During processing of DENON LINK, the "D.LINK" indicator of the display lights.

DENON LINK 4th uses the clock of the AV amplifier connected by DENON LINK to achieve HDMI signal transfer with little jitter when playing BD.

Advanced AL24 Processing Multi channel

Equipped with "Advanced AL24 Processing" time axis region information volume expansion

In addition to the existing "AL24 Processing Plus" bit expansion technology, DENON has also developed "Advanced AL24 Processing" that dramatically improves information volume in the time axis region using high-speed signal detection and processing technology. In addition to expanding original 16-bit digital data to 24 bits, "Advanced AL24 Processing" uses data interpolation along the time axis or upconverted sampling to achieve natural interpolation without losing the original data. A digital filter is used to further expand adaptability and perform optimum filtering calculations for ringing-free pulse response, pulsive music data and attack sounds.

This results in the reproduction of such spatial information as the delicate nuances in the music, the positions of the performers, and the breadth, height, and depth of the concert hall. "Advanced AL24 Processing" is conducted for all channels and modes other than DSD DIRECT. It also operates when the system is 7.1-channel or below.

AL24 Processing Plus

AL24 Processing for All Channels

DENON has further developed its proprietary AL24 Processing, an analog waveform reproduction technology, to support the 192 kHz sampling frequency. AL24 Processing Plus, thoroughly suppresses quantization noise associated with D/A conversion of LPCM signals to reproduce the low-level signals with optimum clarity that will bring out all the delicate nuances of the music.

Equipped for not only front left and right channels but also for the surround left and right, center and subwoofer channels. "AL24 Processing Plus" operates in a system with 8.1 channels or more when digital (PCM) signals are input and the surround mode is as follows:

- PURE DIRECT
- DIRECT
- STEREO
- MULTI CH PURE DIRECT
- MULTI CH DIRECT
- MULTI CH IN

About Networks

Windows Media Player Ver.11

This is a media player distributed free of charge by Microsoft Corporation.

It can be used to play playlists created with Windows Media Player Ver. 11 as well as files in such formats as WMA, DRM WMA, MP3 and WAV.

vTuner

This is a free online contents server for Internet radio. Note that usage fees are included in upgrade costs.

For inquiries about this service, visit the vTuner site below.

vTuner website: <http://www.radiodenon.com>

This product is protected by certain intellectual property rights of Nothing Else Matters Software and BridgeCo. Use or distribution of such technology outside of this product is prohibited without a license from Nothing Else Matters Software and BridgeCo or an authorized subsidiary.

DLNA

- DLNA and DLNA CERTIFIED are trademarks and/or service marks of Digital Living Network Alliance.
- Some contents may not be compatible with other DLNA CERTIFIED™ products.

Windows Media DRM

A copyright-protected technology developed by Microsoft.

Content providers are using the digital rights management technology for Windows Media contained in this device (WM-DRM) to protect the integrity of their content (Secure Content) so that their intellectual property, including copyright, in such content is not misappropriated. This device uses WM-DRM software to play Secure Content (WM-DRM Software). If the security of the WM-DRM Software in this device has been compromised, owners of Secure Content (Secure Content Owners) may request that Microsoft revoke the WM-DRM Software's right to acquire new licenses to copy, display and/or play Secure Content. Revocation does not alter the WM-DRM Software's ability to play unprotected content. A list of revoked WM-DRM Software is sent to your device whenever you download a license for Secure Content from the Internet or from a PC. Microsoft may, in conjunction with such license, also download revocation list onto your device on behalf of Secure Content Owners.

About Wireless LAN

❑ Wi-Fi®

Wi-Fi Certification assures tested and proven interoperability by the Wi-Fi Alliance, a group certifying interoperability among wireless LAN devices.

❑ IEEE 802.11b

This is one wireless LAN standard set by the 802 working group that establishes LAN technology standards at the IEEE (Institute of Electrical and Electronics Engineers) of the United States. It uses the 2.4 GHz band usable freely without a radio frequency license (ISM band), enabling communications at a maximum speed of 11 Mbps.



The value indicated above is the maximum theoretical value for the wireless LAN standard, and does not indicate the actual data transfer rate.

❑ IEEE 802.11g

This is another wireless LAN standard set by the 802 working group that establishes LAN technology standards at the IEEE (Institute of Electrical and Electronics Engineers) of the United States, and is compatible with IEEE 802.11b. It also uses the 2.4 GHz band, but enables communications at a maximum speed of 54 Mbps.



The value indicated above is the maximum theoretical value for the wireless LAN standard, and does not indicate the actual data transfer rate.

❑ Infrastructure Communications

"Infrastructure Communications" refers to networks using wireless LAN access points.

This function can be used to connect to the Internet or a wired LAN via a wireless LAN access point. Wireless LAN access points include wireless broadband routers.

❑ Network Names (SSID: Security Set Identifier)

When forming wireless LAN networks, groups are formed to prevent interference, data theft, etc. This grouping is done by "SSID" or "Security Set Identifiers". For further security, a WEP key is set and signal transfer is not possible unless the SSID and WEP key match.

❑ WEP Key (Network Key)

This is key information used for encrypting data when conducting data transfer. On the AVR-4810, the same WEP key is used for data encryption and decryption, so the same WEP key must be set on both devices in order for communications to be established between them.

❑ WPS (Wi-Fi Protected Setup)

This is a standard drawn up by the Wi-Fi Alliance to ease the task of setting up wireless LAN connections and configuring security. There are two methods: push-button and PIN (Personal Identification Number) code.

❑ WPA (Wi-Fi Protected Access)

This is a security standard established by the Wi-Fi Alliance. In addition to the conventional SSID (network name) and WEP key (network key), it also uses a user identification function and encrypting protocol for stronger security.

❑ WPA2 (Wi-Fi Protected Access 2)

This is a new version of the WPA established by the Wi-Fi Alliance, compatible with more secure AES encryption.

❑ WPA-PSK/WPA2-PSK (Pre-shared Key)

This is a simple authentication system for mutual authentication when a preset character string matches on the wireless LAN access point and client.

❑ Passphrase

This refers to the code key used for WPA-PSK/WPA2-PSK authentication, a WPA authentication method.

❑ TKIP (Temporal Key Integrity Protocol)

This is a network key used for WPA. The encryption algorithm is RC4, the same as for WEP, but the security level is increased by changing the network key used for encryption for each packet.

❑ AES (Advanced Encryption Standard)

This is a next generation standard encryption method replacing the current DES and 3DES, and because of its high security it is expected to be applied widely to wireless LANs in the future. It uses the "Rijndael" algorithm developed by two Belgian cryptographers to divide the data into blocks of fixed lengths and encrypt each block. It supports data lengths of 128, 192 and 256 bits and key lengths of 128, 192 and 256 bits as well, offering extremely high encryption security.

Surround

Surround Modes and Parameters

Surround Mode	Signals and adjustability in the different modes															
	Channel output							Parameter (default values are shown in parentheses)								
	Front L/R	Center	Surround L/R	Surround Back L/R	Subwoofer	Front Wide L/R	Front Height L/R	D. COMP *1	DRC *2	LFE *3	AFDM *3	Surround Back	Cinema EQ.	Mode	Room Size	Effect Level
PURE DIRECT, DIRECT (2ch)	○	×	×	×	◎*4	×	×	○ (OFF)	○ (Auto)	○ (0 dB)	×	×	×	×	×	×
DSD DIRECT	○	×	×	×	×	×	×	×	×	×	×	×	×	×	×	×
DSD MULTI DIRECT	○	◎	◎	◎	◎	×	×	×	×	○ (0 dB)	×	○	×	×	×	×
MULTI CH DIRECT	○	◎	◎	◎	◎	×	×	×	×	○ (0 dB)	○ (ON)	○	×	×	×	×
STEREO	○	×	×	×	◎	×	×	○ (OFF)	○ (Auto)	○ (0 dB)	×	×	×	×	×	×
EXT. IN	○	◎	◎	◎	◎	×	×	×	×	×	×	×	×	×	×	×
MULTI CH IN	○	◎	◎	◎	◎	◎ (NOTE4)	◎ (NOTE3)	×	×	○ (0 dB)	○ (ON)	○	○ (OFF)	×	×	×
WIDE SCREEN	○	◎	◎	◎	◎	◎	◎	○ (OFF)	○ (Auto)	○ (0 dB)	×	○	○ (OFF)	×	×	○ (ON, 10)
DOLBY PRO LOGIC IIz	○	◎	◎	◎	◎	×	◎	○ (OFF)	○ (Auto)	×	×	×	○ (OFF)	○ (Height)	×	×
DOLBY PRO LOGIC IIx	○	◎	◎	◎	◎	◎ (NOTE4)	◎ (NOTE4)	○ (OFF)	○ (Auto)	×	×	○	○ (NOTE1)	○ (Cinema)	×	×
DOLBY PRO LOGIC II	○	◎	◎	×	◎	◎ (NOTE4)	◎ (NOTE4)	○ (OFF)	○ (Auto)	×	×	○	○ (NOTE2)	○ (Cinema)	×	×
DTS NEO:6	○	◎	◎	◎	◎	◎ (NOTE4)	◎ (NOTE4)	○ (OFF)	○ (Auto)	×	×	○	○ (NOTE1)	○ (Cinema)	×	×
DOLBY DIGITAL	○	◎	◎	◎	◎	◎ (NOTE4)	◎ (NOTE3)	○ (OFF)	×	○ (0 dB)	○ (ON)	○	○ (OFF)	×	×	×
DOLBY DIGITAL Plus	○	◎	◎	◎	◎	◎ (NOTE4)	◎ (NOTE3)	○ (OFF)	×	○ (0 dB)	○ (ON)	○	○ (OFF)	×	×	×
DOLBY TrueHD	○	◎	◎	◎	◎	◎ (NOTE4)	◎ (NOTE3)	×	○ (Auto)	○ (0 dB)	○ (ON)	○	○ (OFF)	×	×	×
DTS SURROUND	○	◎	◎	◎	◎	◎ (NOTE4)	◎ (NOTE3)	○ (OFF)	×	○ (0 dB)	○ (ON)	○	○ (OFF)	×	×	×
DTS 96/24	○	◎	◎	◎	◎	◎ (NOTE4)	◎ (NOTE3)	○ (OFF)	×	○ (0 dB)	○ (ON)	○	○ (OFF)	×	×	×
DTS-HD	○	◎	◎	◎	◎	◎ (NOTE4)	◎ (NOTE3)	○ (OFF)	×	○ (0 dB)	○ (ON)	○	○ (OFF)	×	×	×
DTS EXPRESS	○	◎	◎	◎	◎	◎ (NOTE4)	◎ (NOTE3)	○ (OFF)	×	○ (0 dB)	○ (ON)	○	○ (OFF)	×	×	×
MULTI CH STEREO	○	◎	◎	◎	◎	◎	◎	○ (OFF)	○ (Auto)	○ (0 dB)	×	○	×	×	×	×
SUPER STADIUM	○	◎	◎	◎	◎	◎	◎	○ (OFF)	○ (Auto)	○ (0 dB)	×	○	×	×	○ (Medium)	○ (10)
ROCK ARENA	○	◎	◎	◎	◎	◎	◎	○ (OFF)	○ (Auto)	○ (0 dB)	×	○	×	×	○ (Medium)	○ (10)
JAZZ CLUB	○	◎	◎	◎	◎	◎	◎	○ (OFF)	○ (Auto)	○ (0 dB)	×	○	×	×	○ (Medium)	○ (10)
CLASSIC CONCERT	○	◎	◎	◎	◎	◎	◎	○ (OFF)	○ (Auto)	○ (0 dB)	×	○	×	×	○ (Medium)	○ (10)
MONO MOVIE	○	◎	◎	◎	◎	◎	◎	○ (OFF)	○ (Auto)	○ (0 dB)	×	○	×	×	○ (Medium)	○ (10)
VIDEO GAME	○	◎	◎	◎	◎	◎	◎	○ (OFF)	○ (Auto)	○ (0 dB)	×	○	×	×	○ (Medium)	○ (10)
MATRIX	○	◎	◎	◎	◎	◎	◎	○ (OFF)	○ (Auto)	○ (0 dB)	×	○	×	×	×	×
VIRTUAL	○	×	×	×	◎*4	×	×	○ (OFF)	○ (Auto)	○ (0 dB)	×	×	×	×	×	×

○ : Signal / Adjustable

× : No signal / Not adjustable

◎ : Turned on or off by speaker configuration setting

NOTE1 : This parameter is available when the "Mode" is set to "Cinema" (page 81).

NOTE2 : This parameter is available when the "Mode" is set to "Cinema" or "ProLogic" (page 81).

NOTE3 : This parameter is available when the "Front Height" is set to "ON" or "DSX" is set to "ON" (page 82, 84).

NOTE4 : This parameter is available when the "DSX" is set to "ON" (page 84).

NOTE:

*1 : When playing Dolby Digital and DTS signals.

*2 : When playing Dolby TrueHD signal.

*3 : When playing Dolby Digital, DTS, DVD-Audio and Super Audio CD.

*4 : When the "Subwoofer Mode" is set to "LFE+Main" (page 41) only.

Surround Mode	Signals and adjustability in the different modes													
	Parameter (default values are shown in parentheses)													
	Delay Time	Subwoofer	Front Height	PRO LOGIC II/IIx MUSIC mode only			NEO:6 MUSIC mode only	EXT. IN only	Tone Control	MultEQ XT	Dynamic EQ	Dynamic Volume	RESTORER	DSX
Panorama				Dimension	Center Width	Center Image	Subwoofer Att.							
PURE DIRECT, DIRECT (2ch)	×	○	×	×	×	×	×	×	×	×	×	×	×	×
DSD DIRECT	×	×	×	×	×	×	×	×	×	×	×	×	×	×
DSD MULTI DIRECT	×	×	×	×	×	×	×	×	×	×	×	×	×	×
MULTI CH DIRECT	×	×	×	×	×	×	×	×	×	×	×	×	×	×
STEREO	×	×	×	×	×	×	×	×	○ (OFF)	○ (OFF)	○	○	○	×
EXT. IN	×	×	×	×	×	×	×	○	×	×	×	×	×	×
MULTI CH IN	×	×	○ (OFF)	×	×	×	×	×	○ (OFF)	○ (OFF)	○	○	×	○
WIDE SCREEN	×	×	×	×	×	×	×	×	○ (OFF)	○ (OFF)	○	○	○	×
DOLBY PRO LOGIC IIz	×	×	○ (ON)	×	×	×	×	×	○ (OFF)	○ (OFF)	○	○	○	×
DOLBY PRO LOGIC IIx	×	×	○ (OFF)	○ (OFF)	○ (3)	○ (3)	×	×	○ (OFF)	○ (OFF)	○	○	○	○
DOLBY PRO LOGIC II	×	×	○ (OFF)	○ (OFF)	○ (3)	○ (3)	×	×	○ (OFF)	○ (OFF)	○	○	○	○
DTS NEO:6	×	×	×	×	×	×	○ (0.3)	×	○ (OFF)	○ (OFF)	○	○	○	○
DOLBY DIGITAL	×	×	○ (OFF)	×	×	×	×	×	○ (OFF)	○ (OFF)	○	○	×	○
DOLBY DIGITAL Plus	×	×	○ (OFF)	×	×	×	×	×	○ (OFF)	○ (OFF)	○	○	×	○
DOLBY TrueHD	×	×	○ (OFF)	×	×	×	×	×	○ (OFF)	○ (OFF)	○	○	×	○
DTS SURROUND	×	×	○ (OFF)	×	×	×	×	×	○ (OFF)	○ (OFF)	○	○	×	○
DTS 96/24	×	×	○ (OFF)	×	×	×	×	×	○ (OFF)	○ (OFF)	○	○	×	○
DTS-HD	×	×	○ (OFF)	×	×	×	×	×	○ (OFF)	○ (OFF)	○	○	×	○
DTS EXPRESS	×	×	○ (OFF)	×	×	×	×	×	○ (OFF)	○ (OFF)	○	○	×	○
MULTI CH STEREO	×	×	×	×	×	×	×	×	○ (OFF)	○ (OFF)	○	○	○	×
SUPER STADIUM	×	×	×	×	×	×	×	×	○ (NOTE5)	○ (OFF)	○	○	○	×
ROCK ARENA	×	×	×	×	×	×	×	×	○ (NOTE6)	○ (OFF)	○	○	○	×
JAZZ CLUB	×	×	×	×	×	×	×	×	○ (OFF)	○ (OFF)	○	○	○	×
CLASSIC CONCERT	×	×	×	×	×	×	×	×	○ (OFF)	○ (OFF)	○	○	○	×
MONO MOVIE	×	×	×	×	×	×	×	×	○ (OFF)	○ (OFF)	○	○	○	×
VIDEO GAME	×	×	×	×	×	×	×	×	○ (OFF)	○ (OFF)	○	○	○	×
MATRIX	○ (30 ms)	×	×	×	×	×	×	×	○ (OFF)	○ (OFF)	○	○	○	×
VIRTUAL	×	×	×	×	×	×	×	×	○ (OFF)	○ (OFF)	○	○	○	×

○ : Signal / Adjustable

×

NOTE5 : BASS +6 dB, TREBLE 0 dB

NOTE6 : BASS +6 dB, TREBLE +4 dB

Surround

Differences in Surround Mode Names Depending on the Input Signals

Button	Surround Mode	Note	Input signals																				
			ANALOG	LINEAR PCM / WAV	WMA (Windows Media Audio) / MP3 / MPEG-4 AAC / FLAC	DTS-HD		DTS					DOLBY		DOLBY DIGITAL					MULTI CH PCM		Super Audio CD	
						DTS-HD Master Audio	DTS-HD High Resolution Audio	DTS EXPRESS	DTS ES DSCRT (With Flag)	DTS ES MTRX (With Flag)	DTS (5.1ch)	DTS 96/24	DOLBY TrueHD	DOLBY DIGITAL Plus	DOLBY DIGITAL EX (With Flag)	DOLBY DIGITAL EX (With no Flag)	DOLBY DIGITAL (5.1/5/4ch)	DOLBY DIGITAL (4/3ch)	DOLBY DIGITAL (2ch)	PCM (multi ch)	PCM (2ch)	DSD (multi ch)	DSD (2ch)
STANDARD																							
DTS SURROUND																							
	DTS-HD MSTR		×	×	×	●	×	×	×	×	×	×	×	×	×	×	×	×	×	×	×		
	DTS-HD HI RES		×	×	×	×	●	×	×	×	×	×	×	×	×	×	×	×	×	×	×		
	DTS ES DSCRT6.1	*1	×	×	×	×	×	×	●◎	×	×	×	×	×	×	×	×	×	×	×	×		
	DTS ES MTRX6.1	*1	×	×	×	×	×	×	●◎	×	×	×	×	×	×	×	×	×	×	×	×		
	DTS SURROUND		×	×	×	×	×	×	○	○	●	×	×	×	×	×	×	×	×	×	×		
	DTS 96/24		×	×	×	×	×	×	×	×	●	×	×	×	×	×	×	×	×	×	×		
	DTS (-HD) + PLIIx CINEMA	*2	×	×	×	○	○	○	○	○	○	×	×	×	×	×	×	×	×	×	×		
	DTS (-HD) + PLIIx MUSIC	*1	×	×	×	○	○	○	○	○	○	×	×	×	×	×	×	×	×	×	×		
	DTS (-HD) + PLIIz	*3	×	×	×	○	○	○	○	○	○	×	×	×	×	×	×	×	×	×	×		
	DTS EXPRESS		×	×	×	×	×	●	×	×	×	×	×	×	×	×	×	×	×	×	×		
	DTS (-HD) + NEO:6	*1	×	×	×	○	○	○	×	○	○	○	×	×	×	×	×	×	×	×	×		
	DTS NEO:6 CINEMA		○	○	○	×	×	×	×	×	×	×	×	×	×	×	×	○	×	○	×		
	DTS NEO:6 MUSIC		○	○	○	×	×	×	×	×	×	×	×	×	×	×	×	○	×	○	×		
DOLBY SURROUND																							
	DOLBY TrueHD		×	×	×	×	×	×	×	×	×	×	●	×	×	×	×	×	×	×	×		
	DOLBY DIGITAL+		×	×	×	×	×	×	×	×	×	×	×	●	×	×	×	×	×	×	×		
	DOLBY DIGITAL EX	*1	×	×	×	×	×	×	×	×	×	×	×	○	○	○	○	×	×	×	×		
	DOLBY (D+) (HD) +EX	*1	×	×	×	×	×	×	×	×	×	×	○	○	×	×	×	×	×	×	×		
	DOLBY DIGITAL		×	×	×	×	×	×	×	×	×	×	×	×	○	●	●	●	×	×	×		
	DOLBY (D) (D+) (HD) +PLIIx CINEMA	*2	×	×	×	×	×	×	×	×	×	○	○	●◎	○	○	○	×	×	×	×		
	DOLBY (D) (D+) (HD) +PLIIx MUSIC	*1	×	×	×	×	×	×	×	×	×	○	○	○	○	○	○	×	×	×	×		
	DOLBY (D) (D+) (HD) +PLIIz	*3	×	×	×	×	×	×	×	×	×	○	○	○	○	○	○	×	×	×	×		
	DOLBY PRO LOGIC IIz HEIGHT	*3	○	○	○	×	×	×	×	×	×	×	×	×	×	×	×	○	×	○	×		
	DOLBY PRO LOGIC IIx CINEMA	*1	○	○	○	×	×	×	×	×	×	×	×	×	×	×	×	○	×	○	×		
	DOLBY PRO LOGIC IIx MUSIC	*1	○	○	○	×	×	×	×	×	×	×	×	×	×	×	×	○	×	○	×		
	DOLBY PRO LOGIC IIx GAME	*1	○	○	○	×	×	×	×	×	×	×	×	×	×	×	×	○	×	○	×		
	DOLBY PRO LOGIC II CINEMA		○	○	○	×	×	×	×	×	×	×	×	×	×	×	×	○	×	○	×		
	DOLBY PRO LOGIC II MUSIC		○	○	○	×	×	×	×	×	×	×	×	×	×	×	×	○	×	○	×		
	DOLBY PRO LOGIC II GAME		○	○	○	×	×	×	×	×	×	×	×	×	×	×	×	○	×	○	×		
	DOLBY PRO LOGIC		○	○	○	×	×	×	×	×	×	×	×	×	×	×	×	○	×	○	×		

NOTE:
 *1: This mode is not available when the surround back speaker setup is set to "None".
 *2: This mode is not available when the surround back speaker setup is set to "1spkr" or "None".
 *3: This mode is not available when the front height speaker setup is set to "None".
 ● : Mode selectable in initial status
 ◎ : Mode fixed when "AFDM" is "ON"
 ○ : Selectable mode
 × : Non-selectable mode

Button	Surround Mode	Note	Input signals																					
			ANALOG	LINEAR PCM / WAV	WMA (Windows Media Audio) / MP3 / MPEG-4 AAC / FLAC	DTS-HD		DTS					DOLBY		DOLBY DIGITAL					MULTI CH PCM		Super Audio CD		
						DTS-HD Master Audio	DTS-HD High Resolution Audio	DTS EXPRESS	DTS ES DSCRT (With Flag)	DTS ES MTRX (With Flag)	DTS (5.1ch)	DTS 96/24	DOLBY TrueHD	DOLBY DIGITAL Plus	DOLBY DIGITAL EX (With Flag)	DOLBY DIGITAL EX (With no Flag)	DOLBY DIGITAL (5.1/5/4ch)	DOLBY DIGITAL (4/3ch)	DOLBY DIGITAL (2ch)	PCM (multi ch)	PCM (2ch)	DSD (multi ch)	DSD (2ch)	
STANDARD																								
MULTI CH IN																								
	MULTI CH IN		×	×	×	×	×	×	×	×	×	×	×	×	×	×	×	×	×	●	×	●	×	
	MULTI IN + PLIIx CINEMA	*2	×	×	×	×	×	×	×	×	×	×	×	×	×	×	×	×	×	○	×	○	×	
	MULTI IN + PLIIx MUSIC	*1	×	×	×	×	×	×	×	×	×	×	×	×	×	×	×	×	×	○	×	○	×	
	MULTI IN + PLIIz	*3	×	×	×	×	×	×	×	×	×	×	×	×	×	×	×	×	×	○	×	○	×	
	MULTI IN + DOLBY EX	*1	×	×	×	×	×	×	×	×	×	×	×	×	×	×	×	×	×	○	×	○	×	
	MULTI CH IN 7.1	*1	×	×	×	×	×	×	×	×	×	×	×	×	×	×	×	×	×	● ◎ (7.1)	×	×	×	
DIRECT																								
	DIRECT		○	○	○	○	○	○	○	○	○	○	○	○	○	○	○	○	○	○	×	○	×	○
	DSD DIRECT		×	×	×	×	×	×	×	×	×	×	×	×	×	×	×	×	×	×	×	×	○	
	DSD MULTI DIRECT		×	×	×	×	×	×	×	×	×	×	×	×	×	×	×	×	×	×	×	○	×	
	MULTI CH DIRECT		×	×	×	×	×	×	×	×	×	×	×	×	×	×	×	×	×	○	×	○	×	
	M DIRECT + PLIIx CINEMA	*2	×	×	×	×	×	×	×	×	×	×	×	×	×	×	×	×	×	○	×	○	×	
	M DIRECT + PLIIx MUSIC	*1	×	×	×	×	×	×	×	×	×	×	×	×	×	×	×	×	×	○	×	○	×	
	M DIRECT + DOLBY EX	*1	×	×	×	×	×	×	×	×	×	×	×	×	×	×	×	×	×	○	×	○	×	
	M DIRECT 7.1	*1	×	×	×	×	×	×	×	×	×	×	×	×	×	×	×	×	×	○ (7.1)	×	×	×	
PURE DIRECT																								
	PURE DIRECT		○	○	○	○	○	○	○	○	○	○	○	○	○	○	○	○	○	○	×	○	×	○
	DSD PURE DIRECT		×	×	×	×	×	×	×	×	×	×	×	×	×	×	×	×	×	×	×	×	○	
	DSD MULTI PURE DIRECT		×	×	×	×	×	×	×	×	×	×	×	×	×	×	×	×	×	×	×	○	×	
	MULTI CH PURE DIRECT		×	×	×	×	×	×	×	×	×	×	×	×	×	×	×	×	×	○	×	○	×	
	M PURE D + PLIIx CINEMA	*2	×	×	×	×	×	×	×	×	×	×	×	×	×	×	×	×	×	○	×	○	×	
	M PURE D + PLIIx MUSIC	*1	×	×	×	×	×	×	×	×	×	×	×	×	×	×	×	×	×	○	×	○	×	
	M PURE D + DOLBY EX	*1	×	×	×	×	×	×	×	×	×	×	×	×	×	×	×	×	×	○	×	○	×	
	M CH PURE DIRECT 7.1	*1	×	×	×	×	×	×	×	×	×	×	×	×	×	×	×	×	×	○ (7.1)	×	×	×	

NOTE :

- *1: This mode is not available when the surround back speaker setup is set to "None".
- *2: This mode is not available when the surround back speaker setup is set to "1spkr" or "None".
- *3: This mode is not available when the front height speaker setup is set to "None".

- : Mode selectable in initial status
- : Selectable mode
- × : Non-selectable mode

Relationship Between Video Signals and Monitor Output

Video Convert	MAIN ZONE MONITOR OUT													
	Input Signals				Output Signals				GUI menu displayed					
	HDMI	COMPONENT	S-VIDEO	VIDEO	HDMI	COMPONENT	S-VIDEO	VIDEO	HDMI	COMPONENT	S-VIDEO	VIDEO		
ON/OFF	×	×	×	×	×	×	×	×	Only the GUI menu is displayed					
ON	×	×	×	○	VIDEO	VIDEO	VIDEO	VIDEO	○ (VIDEO)	○ (VIDEO)	○ (VIDEO)	○ (VIDEO)		
ON	×	×	○	×	S-VIDEO	S-VIDEO	S-VIDEO	S-VIDEO	○ (S-VIDEO)	○ (S-VIDEO)	○ (S-VIDEO)	○ (S-VIDEO)		
ON	×	×	○	○					○	○	○			
ON	×	○ (1080p)	×	×	COMPONENT	COMPONENT	×	×	○ (COMPONENT)	×	×	×		
ON	×	○ (1080i ~ 480p)	×	×			COMPONENT	COMPONENT		×	×	○ (COMPONENT)	○ (COMPONENT)	○ (COMPONENT)
ON	×	○ (480i/576i)	×	×			×	×	×	×	×	×	×	
ON	×	○ (1080p)	×	○			VIDEO	VIDEO	×	×	○ (VIDEO)	○ (VIDEO)	○ (VIDEO)	
ON * 1	×	○ (1080p)	×	○			×	×	×	×	○ (VIDEO)	○ (VIDEO)	○ (VIDEO)	
ON	×	○ (1080i ~ 480p)	×	○			×	×	×	×	○ (COMPONENT)	○ (COMPONENT)	○ (COMPONENT)	
ON	×	○ (480i/576i)	×	○			COMPONENT	COMPONENT	×	×	○ (COMPONENT)	○ (COMPONENT)	○ (COMPONENT)	
ON	×	○ (1080p)	○	×			×	×	×	×	×	×	×	
ON * 1	×	○ (1080p)	○	×			S-VIDEO	S-VIDEO	×	×	○ (S-VIDEO)	○ (S-VIDEO)	○ (S-VIDEO)	
ON	×	○ (1080i ~ 480p)	○	×			×	×	×	×	○ (COMPONENT)	○ (COMPONENT)	○ (COMPONENT)	
ON	×	○ (480i/576i)	○	×			COMPONENT	COMPONENT	×	×	○ (COMPONENT)	○ (COMPONENT)	○ (COMPONENT)	
ON * 1	×	○ (1080p)	○	×			×	×	×	×	×	×	×	
ON	×	○ (1080i ~ 480p)	○	×	×	×	×	×	×	×	×			
ON	×	○ (480i/576i)	○	×	×	×	×	×	×	×	×			
ON	○	×	×	×	HDMI	×	×	×	○ (HDMI)	×	×	×		
ON	○	×	×	×			VIDEO	VIDEO					×	×
ON	○	×	○	×			S-VIDEO	S-VIDEO					×	×
ON	○	×	○	×			×	×					×	×
ON	○	○	×	×			×	×					×	×
ON	○	○	○	×			×	×					×	×
ON	○	○	○	○			COMPONENT	COMPONENT	×	×				
ON	○	○	○	○			×	×	×	×				
ON	○	○	○	○			S-VIDEO	S-VIDEO	×	×				
ON	○	○	○	○			×	×	×	×				
ON	○	○	○	○			×	×	×	×				
ON	○	○	○	○			×	×	×	×				
OFF	×	×	×	○	×	COMPONENT	×	×	Only the GUI menu is displayed					
OFF	×	×	○	×			VIDEO	VIDEO					×	×
OFF	×	○	×	×			×	×					×	×
OFF	×	○	○	×			×	×					×	×
OFF	×	○	○	×			×	×					×	×
OFF	×	○	○	×			×	×					×	×
OFF	○	×	×	×			×	×					×	×
OFF	○	×	○	×			×	×					×	×
OFF	○	×	○	×			×	×					×	×
OFF	○	○	×	×			×	×					×	×
OFF	○	○	○	×			×	×					×	×
OFF	○	○	○	○			COMPONENT	COMPONENT					×	×
OFF	○	○	○	○	×	×	×	×						
OFF	○	○	○	○	×	×	×	×						
OFF	○	○	○	○	×	×	×	×						

○ : Video signal input present
 × : No video signal input
 * 1 : When no HDMI monitor is connected or the HDMI monitor's power is not on

○ () : Superimposed on the picture indicated in ().
 × () : Only the picture in () is output.
 × : Neither the picture nor the GUI menu is output.
 * 2 : Only the GUI menu is displayed when no HDMI monitor is connected or the HDMI monitor's power is not on.

ZONE2 MONITOR OUT					
INPUT			OUTPUT *3		On-screen display
COMPONENT	S-VIDEO	VIDEO	COMPONENT	S-VIDEO	VIDEO
×	×	×	×	×	Only the OSD menu is displayed
×	×	○	×	VIDEO	○ (VIDEO)
×	○	×	×	S-VIDEO	○ (S-VIDEO)
×	○	○	×	S-VIDEO	○ (S-VIDEO)
○	×	×	COMPONENT	×	Only the OSD menu is displayed
○	×	○	COMPONENT	VIDEO	○ (VIDEO)
○	○	×	COMPONENT	S-VIDEO	○ (S-VIDEO)
○	○	○	COMPONENT	S-VIDEO	○ (S-VIDEO)

* 3 : On-screen display is not displayed.

- The main zone video conversion function is compatible with the following formats: NTSC, PAL, SECAM, NTSC4.43, PAL-N, PAL-M and PAL-60.
- When SECAM signals of video input are up-converted, the signals are output in PAL format from the S-Video and Video connectors.
- The GUI menu display cannot be superimposed when x.v.Color signals, computer's resolution (e.g. VGA) are input.

○ () : Superimposed on the picture indicated in ().

Getting Started
 Connections
 Settings
 Playback
 Multi-zone
 Remote Control
 Information
 Troubleshooting
 Specifications

Troubleshooting

If a problem should arise, first check the following:

1. Are the connections correct?

2. Is the set being operated as described in the owner's manual?

3. Are the other components operating properly?

If this unit does not operate properly, check the items listed in the table below. Should the problem persist, there may be a malfunction.

In this case, disconnect the power immediately and contact your store of purchase.

[General]

Symptom	Cause / Countermeasure	Page
Set does not operate properly.	<ul style="list-style-type: none"> Reset the microprocessor. 	123
Power does not turn on, or turns off directly after it was turned on.	<ul style="list-style-type: none"> Check that the power plugs are securely inserted into the AVR-4810's AC inlet and the wall power outlet. 	27
No sound is produced from speakers.	<ul style="list-style-type: none"> Check the connections to the input devices and the speaker cable connections. 	14 ~ 26
	<ul style="list-style-type: none"> Check the connections to the playback devices and select the appropriate input source. 	17 ~ 26, 30
	<ul style="list-style-type: none"> Adjust the master volume to an appropriate level. 	76
	<ul style="list-style-type: none"> Cancel the mute mode. 	76
	<ul style="list-style-type: none"> Disconnect the headphones. No sound is output from the speakers or the PRE OUT terminals when headphones are connected. 	76
Display is off.	<ul style="list-style-type: none"> Select an input source for which the digital input setting has been made. 	58
	<ul style="list-style-type: none"> Match the terminal to which the digital input terminal is assigned with the input mode. 	61
"DOLBY DIGITAL" indicator does not appear on display.	<ul style="list-style-type: none"> Set "Dimmer" to a setting other than "OFF". 	55
	<ul style="list-style-type: none"> Cancel the PURE DIRECT mode. The display turns off when in the Pure Direct mode. 	80
"DOLBY DIGITAL" indicator does not appear on display.	<ul style="list-style-type: none"> Check the Blu-ray Disc player / DVD player's audio output setting. For details, read the Blu-ray Disc player / DVD player's operating instructions. 	-

Symptom	Cause / Countermeasure	Page
Power switches off suddenly while you are using the AVR-4810, the power indicator will flash in red at intervals of approximately 2 seconds.	<ul style="list-style-type: none"> The protection circuit will be activated depending upon the temperature rise in the internal parts of the unit. Please switch off power at once, and re-apply the power after the body temperature has fallen sufficiently. Please re-install AVR-4810 in a place having good ventilation. 	-
Power switches off suddenly while you are using the AVR-4810, the power indicator will flash red at intervals of approximately 0.5 seconds.	<ul style="list-style-type: none"> Please use speakers which have the specified impedance. The protection circuit has been activated because the core wires of different speaker cables have touched each other or a core wire has slipped out of the terminal and is touching the AVR-4810's rear panel. Unplug the power cord, then after twisting the core wires together tightly again, or effecting termination treatments etc, please reconnect once again. 	16 16
Even applying power, the power display flashes red at intervals of approximately 0.5 seconds.	<ul style="list-style-type: none"> The AVR-4810 amplifier circuit has failed. Switch off the power and please contact the DENON service adviser. 	-

[Remote Control Unit]

Symptom	Cause / Countermeasure	Page
Set does not work properly when remote control unit operated.	<ul style="list-style-type: none"> Batteries are worn. Replace with new batteries. 	3
	<ul style="list-style-type: none"> Operate the remote control unit within a distance of about 7 m from the AVR-4810 and at an angle of within 30°. 	3
	<ul style="list-style-type: none"> Remove the obstacle between the AVR-4810 and the remote control unit. 	-
	<ul style="list-style-type: none"> Insert the batteries in the proper direction, checking the ⊕ and ⊖ marks. 	3
	<ul style="list-style-type: none"> The set's remote control sensor is exposed to strong light (direct sunlight, inverter type fluorescent bulb light, etc.). Move the set to a place in which the remote control sensor will not be exposed to strong light. 	3
	<ul style="list-style-type: none"> Make sure the remote control IDs of the main unit and remote control unit match. If the IDs do not match, "AVAMP *" (* is the main unit's remote control ID) appears on the AVR-4810 display when the remote control unit is operated. 	55, 104, 109
	<ul style="list-style-type: none"> Set the remote control unit's function button properly. 	7

[Audio]

Symptom	Cause / Countermeasure	Page
No sound is produced from center speaker.	<ul style="list-style-type: none"> When playing monaural audio sources, select a surround mode other than "STANDARD" (Dolby/DTS Surround). 	78 ~ 80
No sound is produced from surround speakers.	<ul style="list-style-type: none"> Set the surround mode to a mode for surround playback. 	78 ~ 80
No sound is produced from surround back speaker.	<ul style="list-style-type: none"> Check that the surround back speaker's power amplifier assignment is set to "Normal". 	40
	<ul style="list-style-type: none"> Set the surround back speakers to something other than "None". 	40
	<ul style="list-style-type: none"> Set "Surround Parameter" – "Surround Back" to something other than "OFF". 	82
	<ul style="list-style-type: none"> Set the surround mode to the surround playback mode. 	78 ~ 80
No sound is produced from subwoofer.	<ul style="list-style-type: none"> Turn on the subwoofer's power. 	–
	<ul style="list-style-type: none"> Set the subwoofer to "Yes". 	40
	<ul style="list-style-type: none"> Check the subwoofer connections. 	14
	<ul style="list-style-type: none"> Increase the subwoofer's channel level. 	91
DTS sound is not output.	<ul style="list-style-type: none"> Set the Blu-ray disc/DVD player's audio output setting to "Bit-stream". For details, refer to the Blu-ray disc/DVD player's operating instructions. 	–
	<ul style="list-style-type: none"> Use a DTS-compatible Blu-ray disc player/DVD player. 	–
	<ul style="list-style-type: none"> Set the decode mode to "Auto" or "DTS". 	61
Dolby TrueHD, DTS-HD, Dolby Digital Plus audio is not output.	<ul style="list-style-type: none"> Make HDMI connections. 	17
	<ul style="list-style-type: none"> Set the Blu-ray disc/DVD player's audio output setting to "Bit-stream". For details, refer to the Blu-ray disc/DVD player's operating instructions. 	–
	<ul style="list-style-type: none"> Use a DTS-compatible Blu-ray disc player. 	–

[Control dock for iPod]

Symptom	Cause / Countermeasure	Page
iPod cannot be played.	<ul style="list-style-type: none"> Connect to the terminal to which "iPod dock" was assigned and switch the input source. 	30, 59
	<ul style="list-style-type: none"> Check the iPod connections. 	19
	<ul style="list-style-type: none"> Plug the control dock for iPod's AC adapter into a power outlet. Communications with the AVR-4810 are not possible unless the AC adapter is plugged in. 	–

[Video]

Symptom	Cause / Countermeasure	Page
No picture appears.	<ul style="list-style-type: none"> Check the connections of the AVR-4810's video output terminals and the TV's input terminals. 	17, 18
	<ul style="list-style-type: none"> Make the proper input setting for the input terminals of the TV connected to the AVR-4810. 	–
	<ul style="list-style-type: none"> Cancel the PURE DIRECT mode. 	80
	<ul style="list-style-type: none"> High definition (1080i/720p) and progressive (480p/576p) video signals are not down-converted. Set the player to interlace (480i/576i) signals. 	–
Picture cannot be recorded.	<ul style="list-style-type: none"> Check the "Video Select" setting. 	60
	<ul style="list-style-type: none"> The REC OUT video terminal does not have a video conversion function, so use a video cable to input video signals, an S-Video cable to input S-Video signals. 	20
DVDs cannot be copied on a VCR.	<ul style="list-style-type: none"> This is not a malfunction. Most movie software includes copy prevention signals and cannot be copied. 	–
GUI is not displayed.	<ul style="list-style-type: none"> Set "Format" according to the format (NTSC or PAL) of the TV being used. 	52

[HDMI]

Symptom	Cause / Countermeasure	Page
HDMI audio signals are not output from speakers.	<ul style="list-style-type: none"> Set "HDMI Audio Out" to "AMP" to output HDMI audio signals from the speakers. 	42
No picture appears with HDMI connections.	<ul style="list-style-type: none"> Check the connection of the HDMI connectors. 	17
	<ul style="list-style-type: none"> Select the input source assigned to the HDMI terminal at "HDMI". 	30, 58
	<ul style="list-style-type: none"> Connect a monitor that is compatible with copyright protection (HDCP). 	17
	<ul style="list-style-type: none"> Check that the output format (HDMI FORMAT) of the connected player, etc., matches the TV's compatible input formats. 	17, 18
	<ul style="list-style-type: none"> Depending on the monitor you have connected, the display may not be correct when you set to "Auto (Dual)". In such a case, set to either "Monitor 1" or "Monitor 2". 	42
No sound is output from the monitor connected with HDMI connections.	<ul style="list-style-type: none"> Set "HDMI Audio Out" to "TV" to output HDMI audio signals from the TV. 	42
When performing the following operations on a connected device, AVR-4810 has the same operations. <ul style="list-style-type: none"> Power ON/OFF Switching audio output devices Adjust volume Switch input source 	<ul style="list-style-type: none"> Set "HDMI Control" – "Control" to "OFF". When you only want to operate the power on/off each device, set "Power Off Control" to "OFF". 	43

[NET/USB / Napster]

Symptom	Cause / Countermeasure	Page
When a USB memory device is connected, "USB" is not displayed on the GUI menu.	• The set cannot recognize a USB memory device. Check the connection.	23
	• A USB memory device not conforming to mass storage class or MTP standards is connected. Connect a USB memory device conforming to mass storage class or MTP standards.	-
	• The set port and the connected port do not match. Connect to the port set at "USB Select".	62
	• A USB memory device that the set cannot recognize is connected. This is not a malfunction. DENON does not guarantee that all USB memory devices will operate or receive power.	-
Files on a USB memory device cannot be played.	• USB memory device is in format other than FAT16 or FAT32. Set the format to FAT16 or FAT32. For details, refer to the USB memory device's operating instructions.	-
	• USB memory device is divided into multiple partitions. When divided into multiple partitions, only files stored in the top partition can be played.	-
	• Files are stored in a non-compatible format. Record the files in a compatible format.	70
The file names are not displayed properly (".." etc.).	• You are attempting to play a file that is copyright protected. Files that are copyright protected cannot be played on this set.	70
	• Characters that cannot be displayed are used. This is not a malfunction. On this set, characters that cannot be displayed are replaced with a "." (period).	-
Internet radio cannot be played.	• Ethernet cable is not properly connected or network is disconnected. Check the connection status.	25, 26
	• Program is being broadcast in non-compatible format. Only Internet radio programs in MP3 and WMA can be played on this set.	69, 70
	• The computer's or router's firewall is activated. Check the computer's or router's firewall settings.	-
	• Radio station is not currently broadcasting. Choose a radio station that is currently broadcasting.	71, 72
Files stored on a computer cannot be played.	• IP address is wrong. Check the set's IP address.	50
	• Files are stored in a non-compatible format. Record in a compatible format.	69, 70
	• You are attempting to play a file that is copyright protected. Files that are copyright protected cannot be played on this set.	69
	• Set and computer are connected by USB cable. The set's USB port cannot be used for connection to a computer.	-

Symptom	Cause / Countermeasure	Page
Server is not found, or it is not possible to connect to the server.	• The computer's or router's firewall is activated. Check the computer's or router's firewall settings.	-
	• Computer's power is not turned on. Turn on the power.	-
	• Server is not running. Launch the server.	-
	• Set's IP address is wrong. Check the set's IP address.	50
iPod cannot be played.	• Some iPods do not support being used connected directly to the USB port.	23
Cannot connect to preset or favorite radio stations.	• Radio station is not currently broadcasting. Wait a while before trying again.	-
	• Radio station is not currently in service. It is not possible to connect to radio stations that are no longer in service.	-
For some radio stations, "Server Full" or "Connection Down" is displayed and station cannot be connected to.	• Station is congested or not currently broadcasting. Wait a while before trying again.	-
Sound is broken during playback.	• Network's signal transfer speed is slow or communications lines or radio station is congested. This is not a malfunction. When playing broadcast data with a high bit rate, the sound may be broken, depending on the communications conditions.	-
Sound quality is poor or played sound is noisy.	• File being played has a low bit rate. This is not a malfunction.	-
Cannot compile Playlist.	• The AVR-4810 does not respond to playlist compilation. When the playlist is compiled in PC Application, it is registered to "My Library". In this way, the playlist can be played in AVR-4810.	-
Cannot delete Tracks, Playlists, Channels registered in "My Library".	• Cannot be done with AVR-4810. Delete from PC Application.	-
Cannot login to Napster. ("Incorrect Username or Password" is displayed.)	• Login information is incorrect. Check if the Username for Napster has been properly entered. Re-enter the Password. (Password is not displayed.) http://www.napster.com/choose/index_default.html	50

[Wireless LAN]

Symptom	Cause / Countermeasure	Page
Cannot connect to network.	<ul style="list-style-type: none"> The settings of the SSID and network key (WEP) are incorrect. Match the network settings with the AVR-4810's settings. The reception is poor and the signals cannot be received. Shorten the distance from the wireless LAN's access point, remove any obstacles and otherwise improve visibility, then try reconnecting. Also install away from microwave ovens and the access points of other networks. There are multiple networks and the usable channels overlap. Set the access point's channel settings away from the channels used for other networks. Alternatively, connect using a network cable. 	45 ~ 47 — —
Played sound is interrupted or sound cannot be played.	<ul style="list-style-type: none"> There are multiple networks and the usable channels overlap. Set the access point's channel settings away from the channels used for other networks. Alternatively, connect using a network cable. 	—

Restoring All the Settings to as They were at the Time of Purchase (Resetting the Microprocessor)

Perform this procedure if the display is abnormal or if operations cannot be performed. When the microprocessor is reset, all the settings are reset to their default values.

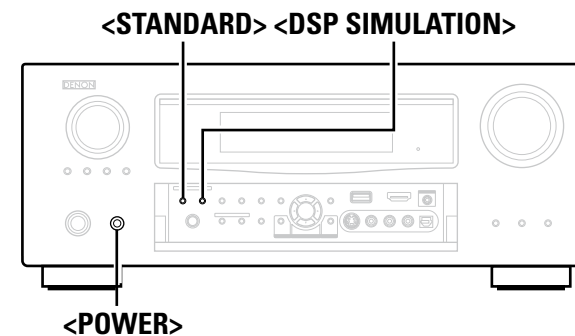

1 Turn off the power using **<POWER>**.

2 Press **<POWER>** while simultaneously pressing **<STANDARD>** and **<DSP SIMULATION>**.

3 Once the display starts flashing at intervals of about 1 second, release the two buttons.

※ Do not turn off the power until the power indicator stops flashing.



If in step 3 the display does not flash at intervals of about 1 second, start over from step 1.

Specifications

Audio section

Power amplifier

Rated output:

Front:
140 W + 140 W (8 Ω/ohms, 20 Hz ~ 20 kHz with 0.05 % T.H.D.)
180 W + 180 W (6 Ω/ohms, 1 kHz with 0.7 % T.H.D.)

Center:

140 W (8 Ω/ohms, 20 Hz ~ 20 kHz with 0.05 % T.H.D.)
180 W (6 Ω/ohms, 1 kHz with 0.7 % T.H.D.)

Surround:

140 W + 140 W (8 Ω/ohms, 20 Hz ~ 20 kHz with 0.05 % T.H.D.)
180 W + 180 W (6 Ω/ohms, 1 kHz with 0.7 % T.H.D.)

Surround back:

140 W + 140 W (8 Ω/ohms, 20 Hz ~ 20 kHz with 0.05 % T.H.D.)
180 W + 180 W (6 Ω/ohms, 1 kHz with 0.7 % T.H.D.)

Front height / Front wide:

140 W + 140 W (8 Ω/ohms, 20 Hz ~ 20 kHz with 0.05 % T.H.D.)
180 W + 180 W (6 Ω/ohms, 1 kHz with 0.7 % T.H.D.)

Dynamic power:

150 W x 2ch (8 Ω/ohms)
220 W x 2ch (4 Ω/ohms)

Output connectors:

Analog

Input sensitivity / Input impedance:

200 mV / 12 kΩ/kohms (except for EXT. IN (SW / S / SB), CD, PHONO, V. AUX)
200 mV / 47 kΩ/kohms (EXT. IN (SW / S / SB), CD, PHONO, V. AUX)

Frequency response:

10 Hz ~ 100 kHz +1, -3 dB (DIRECT mode)

S/N:

102 dB (IHF-A weighted, DIRECT mode)

Distortion:

0.005 % (20 Hz ~ 20 kHz) (DIRECT mode)

Rated output:

1.2 V

Digital

D/A output:

Rated output — 2 V (at 0 dB playback)
Total harmonic distortion — 0.008 % (1 kHz, at 0 dB)
S/N ratio — 102 dB
Dynamic range — 100 dB
Format — Digital audio interface

Digital input:

Phono equalizer (PHONO input — REC OUT)

Input sensitivity:

2.5 mV

RIAA deviation:

±1 dB (20 Hz to 20 kHz)

S/N:

74 dB (A weighting)

Rated output:

150 mV

Distortion factor:

0.03 % (1 kHz, 3 V)

Video section

Standard video connectors

Input / output level and impedance:

1 V_{p-p}, 75 Ω/ohms

Frequency response:

5 Hz ~ 10 MHz — +0, -3 dB (when video convert set to "OFF")

S-Video connectors

Input / output level and impedance:

Y (brightness) signal — 1 V_{p-p}, 75 Ω/ohms
C (color) signal — 0.3 (PAL) / 0.286 V_{p-p} (NTSC), 75 Ω/ohms

Frequency response:

5 Hz ~ 10 MHz — +0, -3 dB (when video convert set to "OFF")

Color component video connector

Input / output level and impedance:

Y (brightness) signal — 1 V_{p-p}, 75 Ω/ohms
P_B / C_B signal — 0.7 V_{p-p}, 75 Ω/ohms
P_R / C_R signal — 0.7 V_{p-p}, 75 Ω/ohms

Frequency response:

5 Hz ~ 100 MHz — +0, -3 dB (when video convert set to "OFF")

Tuner section

Receiving Range:

[FM]
(note: μV at 75 Ω/ohms, 0 dBf = 1 × 10⁻¹⁵ W)
87.5 MHz ~ 108.0 MHz

Usable Sensitivity:

1.0 μV (11.2 dBf)

50 dB Quietening Sensitivity:

MONO 1.6 μV (15.3 dBf)

STEREO 23 μV (38.5 dBf)

S/N (IHF-A):

MONO 77 dB

STEREO 72 dB

Total harmonic Distortion (at 1 kHz):

MONO 0.2 %

STEREO 0.3 %

[AM]

522 kHz ~ 1611 kHz

19 μV

Wireless LAN

Network type (wireless LAN standards):

Conforming to IEEE 802.11b

Conforming to IEEE 802.11g

(Conforming to Wi-Fi®)*

Transfer rate:

DS-SS: 11 / 5.5 / 2 / 1 Mbps (Automatic switching)

Security:

OFDM: 54 / 48 / 36 / 24 / 18 / 12 / 9 / 6 Mbps (Automatic switching)

SSID (Network name)

WEP key (network key) (64/128 bits)

WPA-PSK (TKIP/AES)

WPA2-PSK (TKIP/AES)

Used frequency range:

2,412 MHz ~ 2,472 MHz

No. of channels:

Conforming to IEEE 802.11b : 13ch (DS-SS) (Of which 1 channel used)

Conforming to IEEE 802.11g : 13ch (OFDM) (Of which 1 channel used)

General

Power supply:

AC 230 V, 50 Hz

Power consumption:

910 W

0.1 W (Standby)

Maximum external dimensions:

434 (W) x 195 (H) x 424 (D) mm

Weight:

19.1 kg

Main remote control unit (RC-1126)

Batteries:

LR6/AA Type (two batteries)

Maximum external dimensions:

63 (W) x 238 (H) x 31 (D) mm

Weight:

190 g (including batteries)

Sub remote control unit (RC-1121)

Batteries:

R03/AAA Type (two batteries)

Maximum external dimensions:

49 (W) x 220 (H) x 24.5 (D) mm

Weight:

114 g (including batteries)

* : Wi-Fi® conformity indicates tested and proven interoperability by the "Wi-Fi Alliance", a group certifying interoperability among wireless LAN devices.

※ For purposes of improvement, specifications and design are subject to change without notice.

List of preset codes / Liste von voreingestellten Codes / Liste de codes pré-réglés / Lista dei codici pre-regolati / Lista de códigos pre-ajustados / Lijst van voorinstelde codes / Förteckning över förinställda koder

Blu-ray Disc Player

D	Denon	32258
I	Integra	32147
L	LG	30741
M	Marantz	32414
O	Onkyo	32147
P	Panasonic	31641
	Philips	32084, 32434
	Pioneer	30142, 32442
S	Samsung	30199
	Sharp	32250
	Sony	31516

HD-DVD Player

I	Integra	31769
L	LG	30741
M	Microsoft	32083
O	Onkyo	31769
R	RCA	31769
T	Toshiba	31769
X	Xbox	32083

DVD Player

1	3D LAB	30539
	4Kus	31158
A	A-Trend	30714
	Acoustic Solutions	30713, 31228
	AEG	30770, 30675, 30788, 31233, 32173
	AFK	31152
	AG Electronics	31228
	Airis	30672, 31005, 31224, 31250, 31321, 31345
	Aiwa	30533, 30641
	Akai	30788, 30884, 30898, 31115, 31205, 31233, 31695
	AKI	31005
	Akura	30898, 31233, 31367
	Alba	30539, 30695, 30672, 30713, 30783, 30884, 31530, 31695
	Alize	31151
	All-Tel	31451
	Altacom	31224
	Amitech	30770, 30850
	Amstrad	30770, 30713, 31151, 31367
	Ansonic	30774, 30831, 30759
	Apex Digital	30672
	Arena	31115
	Aristona	30539, 30646
	Asono	31224

	Atacom	31224
	Audiosonic	30690
	Audix	30713
	Autovox	30713
	Auvio	30490, 30634, 31634, 31844, [32134]*
B	Basic Line	30713
	Baze	30898
	BBK	30862, 31224
	Beep	31163
	Belson	31086
	Black Diamond	30713, 30833, 30884
	Blu:sens	31233, 31321
	Blue Nova International	31321
	Blue Sky	30695, 30651, 30672, 30713, 30843, 30884
	Boman	30783, 30898, 31005
	Bose	32023
	Brainwave	30770, 31115
	Brandt	30503, 30551, 30651
	Broksonic	30695
	Bush	30831, 30672, 30690, 30713, 30723, 30733, 30833, 30884, 31367, 31419, 31483, 31530, 31695
C	Cambridge Audio	30751, 31109
	Cat	30789
	cello	31730
	Centrum	30675, 30713, 30789, 31005
	CGV	30733, 30751, 31115
	Cinea	30841
	Cinetec	30713
	CJ Digital	32173
	Classic	31730
	Clatronic	30672, 30675, 30788, 31233
	Clayton	30713
	Codex	31233
	Commax	31321
	Contel	30788
	Continental Edison	30831
	Crown	30770, 30690, 30713, 31115
	Crypto	31228
	Cybercom	30831
	CyberHome	30714, 30816, 31023
	Cytron	30774, 30651, 30705
D	D-Vision	31115, 31367
	Daewoo	30770, 30705, 30714, 30833, 31483
	Dalton	31036
	Dansai	30770, 30783, 31115, 31695
	Dantax	30539, 30713, 30723
	Daytek	31005

	Dayton	31158
	Daytron	31040
	DCE	30831
	Decca	30770, 31115
	Denon	30490, 30634, 31634, 31844, [32134]*
	Denver	30672, 30788, 30898, 31056, 31104, 31321
	Desay	30843
	Dgtec	30672
	Diamond	30651
	Digihome	30713
	DigiLogic	30713
	Digital	32173
	Digitor	30690
	Digitrex	31056
	DiK	30831
	Dinamic	30788
	Disney	30831
	DiViDo	30705
	DK Digital	30831
	DMTech	30783
	Dragon	30831
	DreamX	31151
	DSE	31730
	Dual	30831, 30651, 30713, 30783, 30884, 31023, 31530
	Durabrand	30831, 30675, 30713, 31023, 31530
E	E:max	30770, 31233, 31321
	eBench	31152
	Eclipse	30723, 30751
	Elfunk	30713, 30850, 30884
	Elin	30770
	Ellion	30850
	Elta	30770, 30672, 30690, 30788, 30850, 31115, 31151, 31233, 32173
	Eltax	31233, 31321
	Emerson	30591, 30705
	Enterprise	30591
	Enzer	31228
	EuroLine	30675, 30788, 31115, 31233
F	Fenner	30651
	Ferguson	30695, 30651, 30713, 30884, 30898, 31695, 31730
	Finlux	30741, 30591, 30770, 30672, 30751, 30783
	Fintec	31530
	Firstline	30713, 30843, 30869, 31530
	Fisher	30670
	Funai	30695, 30675
	Fusion	30862
G	Gateway	31158

	Global Link	31224
	Global Sphere	31152
	Go Video	30783, 30869, 31099
	GoldStar	30741, 30591
	Goodmans	30651, 30690, 30713, 30723, 30783, 30833, 31152, 31530, 31730
	GPX	30741
	Gran Prix	30831, 30898
	Grandin	30713, 31233, 32173
	Grundig	30539, 30551, 30695, 30686, 30651, 30670, 30705, 30713, 30775, 31036, 31695, 31730
	Grunkel	30770, 30831
	GVG	30770
H	H & B	30713, 30841, 30850, 31233, 32173
	Hanseatic	30741, 30783
	Harman/Kardon	30582, 30702, 31229, 31926
	HCM	30788
	HDT	30705, 31197
	HE	31163
	Helios	32192
	Henss	30713
	HiIMAX	30843
	Hitachi	30573, 30664, 30141, 30713, 30884
	Hiteker	30672
	Hoehner	30831, 30651, 30713, 31224, 31530, 32173
	Home Electronics	30770
	Home Tech Industries	31224
	HotMedia	31152
	Humax	30646
	HYD	31233
	Hyundai	30850
I	Ingelen	30788
	Ingersol	31023
	Inno Hit	30713
	Irradio	30869, 31115, 31224, 31233
	IRT	30783
	ISP	30695
J	Jamo	31036
	JBL	31926
	JDV	31367
	Jepssen	31250
	JGC	31530
	JMB	30695
	JVC	30623, 30539, 30503, 30558, 31901, 31602, 31597, 31550, 31275, 31164, 30867
K	Kansas Technologies	31233, 31530
	Karcher	30783, 31367
	Kendo	30831, 30672, 30713, 31483

	Kennex	30770, 30713, 30898
	Kenwood	30490, 30534, 30682
	Kiirio	30770
	King D'Home	30833
	Kiss	30841, 31523
	Koda	31230
	KXD	31321
L	Lenco	30770, 30774, 30651, 30713
	Lenoir	31228
	LG	30741, 30591, 30869, 31544, 31906
	Lifetec	30831, 30651
	Limit	31104
	LiteOn	31058, 31158, 31416
	Lodos	30713
	Loewe	30539, 30741, 30511, 30885
	Logik	30713, 30884
	Logix	30705, 30783
	Luker	31367
	Lumatron	30741, 30695, 30705, 30713, 30833, 31115, 31321
	Lunatron	30741
	Luxman	30573
	Luxor	30713, 30884, 31695, 31730
M	Magnavox	30539, 30503, 30646, 30675, 30713
	Magnex	30723
	Majestic	31345
	Manhattan	30705, 30713
	Marantz	30539
	Mark	30713
	Marquant	30770
	Matsui	30695, 30651, 30672, 30713, 30884, 31695, 31730
	Maxim	30713, 31367
	MBO	30690, 31730
	MDS	30713
	Mecotek	30770
	Mediencom	30751
	Medion	30741, 30630, 30774, 30831, 30651, 30783, 31006, 31345
	Memorex	30831
	Metronic	30690
	Metz	30571, 30525, 30713
	MiCO	30723, 30751, 31223
	Micromaxx	30695, 31695
	Micromedia	30539, 30503
	Micromega	30539, 31005
	Microsoft	30522, 32083
	Microstar	30831
	Minato	30752
	Minax	30713
	Minoka	30770, 31115

Mirror	30752
Mitsubishi	30521, 30713, 31403
Mizuda	30770
MPX	30843
Mustek	31730
Muvid	32173
Mx Onda	30651, 30751, 31223
Mystral	30831
N NAD	30741
Naiko	30770, 31367
Narita	31367
Nevir	30770, 30831, 30672, 31197
Nordmende	30774, 30831
Noriko	30752
Nortek	32173
O Okano	30752
Olidata	30672
Onkyo	30503, 30627, 31612, 31769, 31985
Oopla	31158
Oppo	30575, 32185
Optim	30843
Optimus	30525
Orion	30695, 30713, 31233, 31419, 31695
Oritron	30651
Ormond	30713
P P&B	31451
Pacific	30831, 30713, 30759
Packard Bell	30831, 31321
Palladium	30695, 30713, 31367, 31906
Panasonic	30490, 31834, 31579, 30703, 30632
Panda	30789
peeKTon	30125, 30898, 31040, 31224
Philco	30690, 30733
Philips	30539, 30503, 30646, 32084, 31354, 31340, 31267, 31158, 30885, 30675
Philo	31345
Pioneer	30571, 30525, 30142, 30631, 30632, 31460, 31571, 31965
Plu2	30850
Powerpoint	31005
Prinz	30831
Prism	30831, 30705
Pro2	31345
Proline	30686, 30651, 30672, 30833, 31483
Proscan	30522
Proson	30713
Prosonic	30752
ProVision	31163, 31321
Pye	30539, 30646
R Radionette	30741, 30869, 31906

Radiotone	30713
RCA	30522, 31759
REC	30490
Redstar	30770, 30759, 30763, 30788, 30898, 31040, 31345
Reoc	30752
Revoy	30841
Rex	30838
Richmond	31233
Roadstar	30672, 30690, 30713, 30833, 30898
Rotel	30623, 30558
Rownsonic	30789
S Saba	30551, 30651, 32173
Saivod	30831, 30759, 31367
Salora	30741
Sampo	31321
Samsung	30490, 30573, 30199, 30744, 31044, 31075, 31635, 31748, 31932
Sansui	30695, 30751, 31228, 31230
Sanyo	30670, 30713, 30873, 31228
Scan	30705, 30850
ScanMagic	31730
ScanSonic	31695
Schaub Lorenz	30770, 30788, 31115, 31151
Schneider	30539, 30774, 30831, 30646, 30651, 30705, 30713, 30783, 30788, 30869, 31367
Schoentech	30713
Schwaiger	30752
Scott	30651, 30672, 31005, 31036, 31233
Seeltech	31224, 31451
SEG	30713, 30763, 30884, 31483, 31530
Shanghai	30672
Sharp	30630, 30675, 30713, 30752, 30869, 31256, 31419, 32015
Sherwood	30741
Sigmatek	31005, 31224
Siltex	31224
Silva	30788, 30898
Silva Schneider	30741, 30831, 30869, 30898, 31367
SilverCrest	31152
Sistemas	30672
Skantic	30539, 30713
Skyworth	30898
Sliding	31115
SM Electronic	30690, 31152
Smart	30705, 30713
Sogo	30672
Sonic Blue	30783
Sony	30533, 31981, 31633, 31536, 31533, 31516, 31431, 31070, 31033, 30864, 30772

Sound Color	31233
Soundwave	30713, 30783, 31530
Standard	30831, 30651, 30788, 30898
Star Clusters	31152
Starlogic	31005
Starmedia	31005, 31224
Strato	31152
Strong	30713
Sunkai	30770, 30850
Sunstech	30831
Sunwood	30788, 30898
Supervision	31152
SVA	30672, 30752
Sven	30125
Sylvania	30675
Symphonic	30675
Sytech	30125
T Tandberg	30713, 31695
Tangent	31321
Targa	30741, 31906
Tatung	30770, 31695
Tchibo	30741
TCM	30741
Teac	30741, 30705, 30759
Tec	30898
Technica	30713, 30884, 31367, 31695
Technics	30490, 30703
Technika	30770, 30831, 31115, 31530, 31695
Technisson	31115
Technosonic	31115, 31367
Techwood	30713, 31530
Tedex	31228
Telefunken	30551
Teletech	30713, 30884
Tensai	30770, 30651, 30690
Tevion	30651, 30833, 30898, 31036, 31483, 31730
Theta Digital	30571
Thomson	30551, 30522, 30831, 30117, 31759
Tokai	30788, 30898, 31233
Tom-Tec	30789, 30833
Top Suxess	31224
Toshiba	30503, 30695, 31045, 31510, 31639, 31769
Tosumi	31367
TProgress	30752
TRANS-continents	30831, 30833, 31233, 31321, 31327
Tredex	30843
Trevi	30831
TSM	31224
TVE	30713

U Umax	30690, 31151
United	30695, 30675, 30713, 30788, 30884, 31115, 31152, 31228, 31233, 31367
Universum	30741, 30591, 30713, 30869, 31530
Uptek	30763
upXus	31345
V Venturer	31769
Vestel	30713, 30884, 31530
Vieta	30705
Voxson	30831
Vtrek	31228
W Waitec	31151, 31224, 31233
Waltham	30713, 31530
Welkin	30831
Wellington	30713
Weltstar	30713
Wharfedale	30686, 30713, 30751, 30752, 31115
Wilson	30831, 31233
Windsor	30713
Windy Sam	30573
Woxter	31005, 31151, 31224
X Xbox	30522, 32083
Xoro	30160, 31183, 31250, 31621
Y Yakumo	31056
Yamada	31056, 31151, 31158, 31416
Yamaha	30490, 30539, 30646, 30545, 30817, 31840
Yamakawa	31104
Yukai	31730
Z Zenith	30503, 30591

DVD Recorder

1 4Kus	31158
A Airis	31321
Alba	31530
Aristona	30646
B Belson	31086
Bush	31530
C cello	31730
Centrum	31227
Classic	31730
Commax	31321
CyberHome	31502
Cytron	31347
D Dayton	31158
Denver	31056
Digitrex	31056
DSE	31730
Dual	31530
Durabrand	31502, 31530

E E:max	31321
Ellion	31421
Eltax	31321
F Ferguson	31730
Fintec	31530
Firstline	31530
Funai	30675
G Gateway	31158
Goodmans	31530, 31730
GPX	30741
Grundig	31730
H H & B	31421
Hitachi	30141
Hoehner	31530
Humax	30646
Hyundai	31421
J JGC	31530
JVC	31164, 31275, 31597
K Kansas Technologies	31530
Kreisen	31421
KXD	31321
L LG	30741
Lifetec	31347
LiteOn	31158, 31416
Loewe	30741
Lumatron	31321
Luxor	31730
M Matsui	31730
MBO	31730
Medion	30741, 31347
MiCO	30751
Mustek	31730
O Oopla	31158
P Packard Bell	31321
Panasonic	30490, 31579
Philips	30646, 31158, 31506
Pioneer	30631, 31460
ProVision	31321
Pye	30646
R Relisys	31347
Roadstar	31227
S Samsung	31635, 31748
ScanMagic	31730
Schneider	30646, 31227
SEG	31530
Sharp	31419
Sony	31033, 31070
Soundwave	31530
Star Clusters	31227
Sylvania	30675
T Tangent	31321
Targa	30741, 31227

Teac	31227
Technika	31530
Techwood	31530
Tevion	31227, 31730
Thomson	30551, 30117
Toshiba	31510
U Universum	31227, 31530
V Vestel	31530
W Waltham	31530
Y Yakumo	31056
Yamada	31056, 31158, 31416
Yamaha	30646
Yukai	31730

CD Player

A Acoustic Research	40420
Advantage	40032
AH!	40157
Aiwa	40157
Arcam	40157
Atoll Electronique	40157
Audio Research	40157
Audiolab	40157
Audiomeca	40157
Audioton	40157
AVI	40157
B Balanced Audio Technology	40157
Burmester	40420
Bush	40388
C Cairn	40157
California Audio Labs	40303, 40029
Cambridge	40157
Cambridge Audio	40157
Cambridge Soundworks	40157
Carver	40157, 40179
CDC	40420
CEC	40420
Copland	40393
Cyrus	40157
D Denon	40003, 40766, 40873, 42867, 42868, 43867, 43868
DKK	40000
DMX Electronics	40157
Dual	40003
Dynaco	40157
F Fisher	40179
G Garrard	40393, 40420
Genexxa	40000, 40032, 40037, 40179
Goldmund	40157
Grundig	40157

H Hafler	40173
Harman/Kardon	40157, 40173
I Inkel	40157
J JVC	40072
K Kenwood	40157, 40028, 40190, 40037, 40681
Krell	40157
L Linn	40157
Loewe	40157
M Magnavox	40157
Marantz	40157, 40029
Matsui	40157
MCS	40029
Memorex	40000, 40032, 40468, 40179, 40420
Meridian	40157
Micromega	40157
Miro	40000
Mission	40157
Modulaire	40000, 40032, 40468, 40087, 40179, 40420
Musical Fidelity	40393
Myryad	40157
N NAD	40000, 40721
Naim	40157
O Onkyo	40101, 40868
Optimus	40000, 40032, 40468, 40179, 40420
Orion	40393
P Panasonic	40303, 40029, 40388, 40752
Parasound	40420
Philips	40157
Pioneer	40032, 40468, 40101
Primare	40157
Proton	40157
Q QED	40157
Quad	40157
Quasar	40029
R Radiola	40157
RCA	40053, 40179
Realistic	40179, 40420
Restek	40157
Revox	40157
Roksan	40420
Rotel	40157, 40420
Royal	40420
S SAE	40157
Saisho	40000
Sansui	40157
Sanyo	40087, 40179
Sharp	40037
Siemens	40157
Simaudio	40157
Sony	40000, 40490, 40185

Sylvania	40157
T TAG McLaren	40157
Tandy	40032
Teac	40393, 40420
Technics	40303, 40029
Thomson	40053
Thorens	40157
Thule Audio	40157
Tokai	40420
Universum	40157, 40053
V Victor	40072
W Wadia	40393
Wards	40000, 40157, 40032, 40053, 40087, 40179
Y Yamaha	40036

CD Recorder

D Denon	42868, 43868
S Sony	40100
T Thomson	40053

Video Cassette Recorder

A A-Mark	20278
AEG	21593
Aiko	20278
Aiwa	20037, 20348, 20032, 20742, 21137
Akai	20348, 20315, 20240
Alba	20081, 20278, 20348, 20315
Allorgan	20240
Allstar	20081
America Action	20278
Amstrad	20278
Anam	20278, 20037, 20226, 20240
Anam National	20226, 21162
Aristona	20081
ASA	20081, 20037
Asha	20240
Asuka	20081, 20037
Audiolab	20081
Audiosonic	20278
Audiovox	20037
Awa	20037, 20043
B Baird	20278
Basic Line	20278
Beaumont	20240
Bestar	20278
Black Diamond	20642
Black Panther	20278
Blaupunkt	20081, 20226
Blue Sky	20278, 20037, 20348, 20642, 20742, 21137

Brinkmann	20348
Broksonic	20742
Bush	20081, 20278, 20348, 20642, 20315, 20742
C Calix	20037
Carena	20081
Carrefour	20045
Carver	20081
Cathay	20278
CCE	20278
Centrum	20593, 21593
Cineral	20278
Citizen	20278, 20037
Clatronic	21593
Condor	20278
Craig	20037, 20240
Crosley	20081
Crown	20278, 20037
Cybernex	20240
Cyrus	20081
D Daewoo	20278, 20642, 20045
Dansai	20278
Dantax	20348, 20742
Daytron	20278
De Graaf	20081, 20048, 20042
Decca	20081, 20067
Degraff	20081, 20048, 20042
Deitron	20278
Denon	20081, 20042
Diamant	20037
Dual	20081, 20278, 20348
Dumont	20081
Durabrand	20642, 20593, 21593
E Elbe	20278
Electroponic	20037
Elin	20240
Elta	20278
Emerex	20032
Emerson	20278, 20037, 20045, 20043
ESC	20278, 20240
EuroLine	21593
F Ferguson	20278, 20348, 20742
Fidelity	20240
Finlandia	20081, 20037, 20048, 20043, 20042, 20226
Finlux	20081, 20042
Firstline	20278, 20037, 20348, 20045, 20043, 20042, 21137
Flint	20348
Fujitsu	20037
Fujitsu Siemens	21972
Funai	20278, 20593, 21593
G Galaxis	20278

GE	20048, 20060, 20240
GEC	20081
General Technic	20348
Go Video	21137
GoldStar	20037, 20225, 21137
Goodmans	20081, 20278, 20037, 20348, 20642, 20240, 20742
GPX	20037
Graetz	20240
Granada	20081, 20037, 20048, 20042, 20226, 20240
Grandin	20278, 20037, 20742
Grundig	20081, 20348, 20226, 20742
H Hanseatic	20081, 20037
Hewlett Packard	21972
Hinari	20278, 20240
Hischito	20045
Hitachi	20081, 20037, 20042, 20089, 20240, 20593
Hoeher	20278, 20642
Hornophon	20081
Hughes Network Systems	20042
Hypson	20278, 20037
I Ingersol	20240
Interbuy	20037
Interfunk	20081
Internal	20278
International	20278, 20037, 20642
Intervision	20278, 20037, 20348
Irradio	20081, 20037, 21137
ITT	20240
ITT Nokia	20240
ITV	20278, 20037
J JBL	20278
JMB	20348, 20742
JVC	20067
K Karcher	20081, 20278, 20642
KEC	20278, 20037
Kendo	20278, 20037, 20348, 20642, 20315
Kenwood	20067
Kneissel	20278, 20037, 20348
Kodak	20037
L Lenco	20278
LG	20278, 20037, 20225, 21137
Lifetec	20348
Loewe	20081, 20037, 21162, 21262
Logik	20240
Lumatron	20593, 21137
Lunatron	21137
Luxor	20048, 20043, 20315
LXI	20037
M M Electronic	20037

Magnadyne	20081
Magnasonic	20278, 20593
Magnavox	20081, 21593
Magnin	20240
Magnum	20642
Manesth	20081, 20045
Marantz	20081
Mark	20278
Marta	20037
Mascom	20642
Mastec	20642
Master's	20278
Matsui	20037, 20348, 20240, 20742
Matsushita	21162
Mediator	20081
Medion	20348, 20642
Memorex	20037, 20348, 20048, 20240, 21162, 21262
Metronic	20081
Metz	20081, 20037, 20226, 20837, 21162, 21262
MGA	20043, 20240
MGN Technology	20240
Micormay	20348
Microsoft	21972
Minolta	20042
Mitsubishi	20081, 20642, 20067, 20048, 20043
Motorola	20048
MTC	20240
Multitec	20037
Myryad	20081
N Naiko	20348, 20642
National	20226
NEC	20037, 20067
Neckermann	20081
Neufunk	21137
Nikkai	20278
Nikko	20037
Nishi	20240
Noblex	20240
Nokia	20081, 20278, 20048, 20042, 20315, 20240
Nordmende	20642, 20067
O Oceanic	20081, 20048
Okano	20278, 20348, 20315
Olympus	20226
Onimax	20642
Optimus	20048, 20593, 21162, 21262
Orion	20348, 20742
Osaki	20037
Otto Versand	20081
P Pacific	20348, 20642, 20742
Packard Bell	21972

Palladium	20037, 20348
Panasonic	20226, 20225, 20837, 21162, 21262
Pathe Cinema	20043
Penney	20037, 20042, 20240
Pentax	20042
Philips	20081, 20593, 20618
Phoenix	20278
Phonola	20081
Pilot	20037
Pioneer	20081, 20067, 20042
Portland	20278
Profitronic	20081, 20240
Proline	20278, 20642
Proscan	20060
Proscoc	20278
Prosonic	20278
Protech	20081
ProVision	20278
Pye	20081
Q Quasar	20278, 21162
Quelle	20081
R Radialva	20081, 20037, 20048
Radiola	20081
Radionette	20037, 21137
RadioShack	20037
Radix	20037
Randex	20037
RCA	20048, 20042, 20060, 20240
Realistic	20037, 20048
Reoc	20348
Ricavision	21972
Roadstar	20081, 20278, 20037, 20240, 20742
S Saba	20278
Saisho	20348
Salora	20043
Samsung	20045, 20060, 20240, 20742
Sanky	20048
Sansei	20048
Sansui	20067
Sanyo	20067, 20048, 20240, 21137
Saville	20278, 20240
SBR	20081
ScanSonic	20240
Schaub Lorenz	20348, 20315
Schneider	20081, 20278, 20037, 20348, 20642, 20042, 20240, 21137
Scott	20043, 20593
Sears	20037, 20042
Seaway	20278
SEG	20081, 20278, 20642, 20240, 20593
SEI	20081

Sei-Sinudyne	20081
Seleco	20037
Semp	20045
Sentra	20278
Sharp	20048, 21137
Shivaki	20037
Shogun	20240
Siemens	20081, 20037
Siera	20081
Silva	20037
Silva Schneider	21137
Silver	20278
SilverCrest	20642
Singer	20045
Sinudyne	20081
Smaragd	20348
Sonolor	20048
Sontec	20278, 20037
Sony	20067, 20032, 20048, 20226, 20636, 21032, 21972
Soundwave	20037, 20348
Standard	20278
Stern	20278
STS	20042
Sunkai	20278, 20348
Supra	20037
Susumu	20037
Sylvania	20081, 20043
Symphonic	20593, 21593
T Tandberg	20278
Tashiko	20081, 20037, 20048, 20240
Tatung	20081, 20348, 20067, 20048, 20043
Tchibo	20348
TCM	20348
Teac	20037, 20642
Technics	20081, 20226, 21162
TechniSat	20348
Teknika	20037
Telefunken	20278
Telerent	20226
Teletech	20278
Tensai	20278, 20037
Tevion	20348, 20642
Texet	20278
Thomson	20278, 20067, 20060
Thorn	20037
Tisonic	20278
Tivo	20618, [20739]*
TMK	20240
Tokai	20037
Topline	20348

Toshiba	20081, 20045, 20043, 20742, 21008
Totevision	20037, 20240
Tradex	20081
U Uher	20240
Ultravox	20278
Unitech	20240
United	20348, 20742, 21593
Universum	20081, 20037, 20348, 20240, 21137
V Vector	20045
VIA Technologies	21972
Victor	20067
Video Concepts	20045
Videomagic	20037
Videosonic	20240
W Wards	20081, 20045, 20048, 20042, 20060, 20240
Watson	20081, 20642
Weltblick	20037
Wharfedale	20593
White Westinghouse	20278
World	20348
Y Yamishi	20278
Yoko	20037, 20240
Z ZX	20348

Digital(Personal) Video Recorder

M Microsoft	21972
P Panasonic	20616
Philips	20618
T Toshiba	21008

Digital(Personal) Video Recorder/Satellite Combination

A @sat	01300
Allvision	01412
Amstrad	01175
Atsat	01300
B B@ytronic	00740, 01412
British Sky Broadcasting	01175
BskyB	01175, 01662
Bush	01645
C Canal Satellite	01339
Comag	01412
D DigiFusion	01645
DigiQuest	01300
Digiturk	01076
Dilog	01957

Dish Network System	00775
DMT	01075
Dream Multimedia	01237
E EchoStar	00610
eMTech	01214
F FinnSat	01994
G GbSAT	01214
Gecco	01412
Globo	01412
H Handan	01957
HDT	01159
Hirschmann	00740, 01412
Homecast	01680
Humax	01176, 01427, 01675, 01808
Huth	01075
Hyundai	01075, 01159
K Kathrein	00249, 00658, 00707, 01221, 01561
L LaSAT	00740
LG	01075
M Maximum	01334
Medion	00740, 01412, 01994
Microstar	01075
Morgan's	01412
Multichoice	01333
MySky	01693, 01848, 01850
N NEOTION	01334
Nokia	01023
O Opentel	01412
Orbis	01412
P Pace	01175, 01423, 01693, 01850
Panasonic	01304
Philips	00099
Pilotime	01339
Proscan	00392
R Radix	01317
Rebox	01214
S Sagem	01253, 01307, 01692
Samsung	01175, 01570
Sansui	01545
Sat Control	01300
Schwaiger	00740, 01075, 01412
Serd	01412
Siemens	01657
SKY	01175, 01662, 01693, 01848, 01850
SKY Italia	01848
Sky XL	01412
SkyMaster	01075, 01545
Skypex	00740
Skyplus	01175, 00740, 01334, 01412
Stream System	01300

Sumin	01412
Sunny	01300
T TechniSat	01195, 01197
TELE System	01159
Telestar	01195, 01197
Thomson	01175, 01534, 01662
Topfield	01545, 01783, 01824, 01986
TPS	01253, 01307
X Xtreme	01300
Y Yamada	01993
Z Zehnder	01075, 01412

Digital(Personal) Video Recorder/cable Combination

F Freebox	01482
------------------	-------

Tape Deck

A Aiwa	20029, 20200, 20197
Akai	20283
Arcam	20076
Audiolab	20229, 20029
C Carver	20029
D Denon	20076, 20371, 22471
G Garrard	20308
Grundig	20029
H Harman/Kardon	20182
I Inkel	20070
J JVC	20273, 20244
K Kenwood	20070
M Magnavox	20029
Marantz	20029, 20009
Memorex	20099
Myryad	20029
O Onkyo	20135, 20282
Optimus	20027, 20220
Orion	20308
P Panasonic	20229
Philips	20229, 20029
Pioneer	20099, 20027, 20220
R Radiola	20029
Revox	20029
S Sansui	20029, 20009
Sony	20243, 20170, 20291
T Teac	20308
Technics	20229
Thorens	20029
V Victor	20273, 20244
W Wards	20029, 20027
Y Yamaha	20094, 20097

Television

A A-Mark	10009
A.R. Systems	10556, 10037, 10455, 10352, 10374
Accent	10037
Acer	11403
Acoustic Solutions	11037, 11149, 11523
Acura	10009
ADL	11217
Admiral	10264, 10163
Advent	10876
Adyson	10217
AEG	11556
Agashi	10264, 10217
Aiko	10037, 10361, 10264, 10433, 10009, 10035, 10092, 10217, 10371
Aim	10037, 10805
Aiwa	10264, 10701
Akai	10556, 10037, 10548, 10714, 10715, 10606, 10361, 10264, 10433, 11675, 10702, 10648, 10631, 10602, 10480, 10371, 10217, 10208, 10163, 10035, 10030, 10009, 10000
Akiba	10037, 10218, 10455
Akito	10037
Akura	10037, 10714, 10668, 11037, 10264, 10218, 10009, 10163, 10171, 11363, 11498, 11556, 11982
Alba	10037, 10714, 10668, 11037, 10487, 10370, 10218, 10036, 10009, 10073, 10163, 10352, 10371, 10418, 10443, 10480
All-Tel	10865, 11269
Allorgan	10217
Allstar	10037
Amplivision	10370, 10217
Amstrad	10037, 11037, 10264, 10218, 10433, 10000, 10009, 10163, 10171, 10362, 10371, 10648, 11982
Amtron	10000
Anam	10037, 10009
Anam National	10037, 10650
Andersson	11149
Anglo	10264, 10009
Anitech	10037, 10264, 10009
Ansonic	10037, 10668, 10370, 10009, 10163, 10374
AOC	10625, 10030
Arc En Ciel	10109
Arcam	10217
Ardem	10037, 10714
Arena	10037
Aristocrat	10163
Aristona	10556, 10037

ART	11037
Arthur Martin	10163
ASA	10070, 10346
Asberg	10037
Asora	10009
Asuka	10264, 10218, 10217
Atlantic	10037
Atori	10009
Auchan	10163
Audiosonic	10037, 10714, 10486, 10715, 10264, 10370, 10218, 10009, 10109, 10217, 10374, 10865
Audioton	10486, 10264, 10370, 10217
Audiovox	10092, 10623
Aumark	10060
Autovox	10217
AVP	10000
Awa	10606, 10036, 10108, 10009, 10011, 10217
Axxent	10009
B Baier	10876
Baird	10037, 10073, 10109, 10208, 10217, 10343, 11196
Bang & Olufsen	10565
Barco	10163
Basic Line	10556, 10037, 10668, 11037, 10218, 10455, 10009, 10163, 10217, 10374
Bastide	10217
Bauer	10805
Baur	10037, 10195, 10361, 10512
Bazin	10217
Beaumark	10178
Beko	10037, 10714, 10195, 10486, 10715, 10606, 10370, 10418, 10808
Bell & Howell	10017, 10154
Belson	10698
Belstar	11037
Beon	10037, 10218, 10163, 10418
Berthen	10668
Best	10370
Bestar	10037, 10370, 10374
Bestar-Daewoo	10374
Binatone	10217
Black Diamond	11037, 10614
Blackway	10218
Blaupunkt	10195, 10036, 10455, 10170, 10200, 10327
Blue Sky	10556, 10037, 10625, 10714, 10668, 11037, 10715, 10487, 10218, 10455, 10499, 11149, 11363
Boots	10009, 10217
Bork	11363
BPL	10037, 10208

Brandt	10625, 10714, 10560, 10109, 10287, 10335
Brinkmann	10037, 10668, 10486, 10418
Brionvega	10037, 10362
Britannia	10217
Brother	10264
BSR	10163
BTC	10218
Bush	10556, 10037, 10714, 10668, 11037, 10698, 10487, 10361, 10264, 10218, 10036, 10778, 11149, 11556, 11982, 10661, 10614, 10374, 10371, 10335, 10217, 10208, 10163, 10009
Byd:sign	11309
C Cameron	11523
Camper	10037
Candle	10030
Canton	10218
Capetronic	10030
Capsonic	10264
Carad	10668, 11037, 10610
Carena	10037, 10455
Carnivale	10030
Carrefour	10037, 10036, 10070
Carver	10054, 10170
Cascade	10037, 10009
Casio	10037
Cathay	10037, 10218
CCE	10037
Celebrity	10000
Centrum	11037
Centurion	10037
CGE	10370, 10074, 10163, 10418
Changhong	10821
Cimline	10218, 10009
Cineral	10092
Cinex	10648, 11556
Citizen	10030, 10060, 10092
City	10009
Clarivox	10037, 10070, 10418
Classic	10499
Clatronic	10037, 10714, 10264, 10370, 10218, 10009, 10217, 10371
Clayton	11037
CMS Hightec	10217
Concorde	10009
Condor	10037, 10264, 10370, 10009, 10418
Conia	10820, 11498
Conrac	10808
Contec	10037, 10036, 10009
Continental Edison	10487, 10109, 10287
Cosmel	10037, 10009
Crosley	10370, 10054, 10074, 10163

Crown	10037, 10714, 10668, 11037, 10486, 10715, 10487, 10606, 10712, 10370, 10009, 10053, 10208, 10418, 10672
Crown Mustang	10672
CS Electronics	10218
CTX	11756
Curtis Mathes	10030, 10047, 10051, 10054, 10060, 10145, 10154, 10166
Cybertron	10218
Cytronix	11298
D D-Vision	10556, 10037, 11982
Daewoo	10556, 10037, 10634, 10218, 10880, 10876, 10865, 10778, 10661, 10623, 10499, 10374, 10217, 10178, 10154, 10092, 10009
Dainichi	10218
Daitsu	11267
Dansai	10037, 10036, 10009, 10035, 10208, 10217
Dantax	10714, 11037, 10486, 10715, 10370
Datsura	10208
Dawa	10037
Daytek	11207
Dayton	10009, 11207
Daytron	10037, 10009, 10030, 10092, 10178, 10374
De Graaf	10548, 10163, 10208
Decca	10037, 10217
Degraff	10163, 10208
Dell	11264, 11403, 11863
Denko	10264
Denon	10145
Denver	10037
Desmet	10037, 10009
Diamant	10037
Digatron	10037
Digihome	11149
Digiline	10037, 10668
Digix Media	10880
Dixi	10037, 10009, 10217
DMTech	11937
Domeos	10668
Domland	10394
Dream Vision	11704
DTS	10009
Dual	10037, 11037, 11137, 10217, 10343, 10352, 10394, 10778, 11149, 11267
Dual Tec	10217
Dumont	10017, 10070, 10217
Dux	10037
Dynatech	10217
Dynatron	10037
Dynex	11463

E	Easy Living	10877, 11217, 11248
	Ecco	10773
	ECE	10037
	Edison-Minerva	10487
	Elbe	10556, 10037, 10610, 10218, 10217, 10362
	Elcit	10163
	Electroband	10000
	Elekta	10264
	Elfunk	11037, 11208
	ELG	10037
	Elin	10037, 10548, 10361, 10009
	Elite	10037, 10218
	Elta	10264, 10009
	Emerson	10037, 10714, 10668, 10486, 10361, 10370, 10036, 10017, 10047, 10070, 10073, 10154, 10170, 10178, 10371, 10623
	Envision	10030
	Erae	11371
	Erres	10037
	ESC	10037, 10217
	Etron	10009, 10163
	Eurofeel	10264, 10217
	Euroman	10037, 10264, 10370, 10217
	Europa	10037
	Europhon	10037, 10109, 10217
	Evesham	11248
	Evolution	11756
	Excello	11037
	Expert	10163
	Exquisit	10037
F	Fenner	10009, 10374
	Fer0	10335
	Ferguson	10037, 10625, 10548, 10560, 10195, 11037, 10053, 10073, 10109, 10287, 10335, 10343, 10443
	Fidelity	10037, 10361, 10264, 10163, 10171, 10217, 10371, 10512
	Filsai	10217
	Finlandia	10548, 10361, 10163, 10208, 10346
	Finlux	10556, 10037, 10714, 10715, 10070, 10163, 10217, 10346, 10480, 10631, 10808, 11556
	Firstline	10556, 10037, 10714, 10668, 11037, 10361, 10009, 10208, 10217, 10374, 10808, 11363, 11371
	Fisher	10361, 10370, 10036, 10000, 10047, 10054, 10154, 10208, 10217
	Flint	10037, 10610, 10264, 10218, 10455
	Force	11149
	Formenti	10037, 10163
	Fraba	10037, 10370

	Friac	10037, 10610, 10370, 10009, 10499
	Frontech	10264, 10009, 10163, 10217
	Fujimaro	10865
	Fujitsu	10009, 10217, 10683, 10809, 10853
	Fujitsu General	10009, 10217, 10683
	Fujitsu Siemens	10808, 11248, 11298
	Funai	10714, 10668, 11037, 10264, 10171, 11394, 11817
G	Gaba	11037
	Galaxi	10037
	Galaxis	10037, 10370
	Gateway	11755
	GBC	10218, 10009, 10163, 10374
	GE	10047, 10051, 10178, 10335, 11147, 11347
	GEC	10037, 10361, 10163, 10217
	Geloso	10009, 10163, 10374
	General	10109, 10287
	General Technic	10009
	Genexxa	10037, 10218, 10009, 10163
	Gericom	10808, 10865, 10880, 11206, 11217, 11298
	Gibraltar	10017, 10030
	Go Video	10060
	Gold Vision	10661
	Goldfunk	10668
	GoldStar	10037, 10714, 10715, 10606, 10361, 10455, 10001, 10030, 10109, 10163, 10178, 10217
	Gooding	10487
	Goodmans	10556, 10037, 10625, 10714, 10560, 10668, 10634, 11037, 10487, 10264, 10218, 10036, 10661, 10808, 10880, 11149, 10499, 10480, 10374, 10371, 10343, 10335, 10217, 10035, 10011, 10009, 10000
	Gorenje	10370
	GPM	10218
	Gradiente	10037, 10053, 10170
	Graetz	10714, 10487, 10361, 10163, 10371
	Gran Prix	10648
	Granada	10037, 10548, 10560, 10036, 10108, 10226, 10163, 10208, 10217, 10343
	Grandin	10556, 10037, 10714, 10668, 11037, 10715, 10610, 10218, 10455, 11298, 11206, 10880, 10865, 10374, 10163, 10009
	Gronic	10217
	Grundig	10556, 10037, 10195, 10487, 10706, 10036, 10070, 10163, 10443, 10672, 11371
H	H & B	10808
	Haier	10698, 11749
	Halifax	10264, 10217
	Hallmark	10178

	Hampton	10217
	Hanimex	10218
	Hanseatic	10556, 10037, 10625, 10714, 10634, 10361, 10370, 10009, 10217, 10394, 10499, 10661, 10808
	Hantarex	10037, 10009, 10865
	Hantor	10037
	Harman/Kardon	10054
	Harsper	10865, 11206
	Harwa	10773, 11196, 11269
	Harwood	10037, 10487, 10009
	Hauppauge	10037
	HCM	10037, 10264, 10218, 10009, 10217, 10418
	Hema	10009, 10217
	Hifivox	10109
	Highline	10037, 10264
	Hikona	10218
	Hikone	10218
	Hinari	10037, 10264, 10218, 10036, 10009, 10163, 10208, 10352, 10443
	Hisawa	10714, 10610, 10218, 10455
	Hisense	10556, 10508, 10780, 11363
	Hitachi	10037, 10548, 10634, 11037, 11137, 10036, 10108, 10578, 10744, 10877, 11149, 11225, 11576, 11691, 10499, 10481, 10480, 10343, 10217, 10178, 10163, 10150, 10145, 10109, 10054, 10051, 10047, 10035, 10000
	Hitachi Fujian	10108, 10150
	Hitsu	10610, 10218, 10455, 10009
	Hoeher	10714, 10865, 11556
	Home Electronics	10606
	Hornophon	10037
	Hoshai	10218, 10455
	Huanyu	10217, 10374
	Hugoson	11217
	Hygashi	10217
	Hyper	10009, 10217
	Hypersonic	10361
	Hypson	10556, 10037, 10714, 10668, 11037, 10486, 10715, 10264, 10455, 10217
	Hyundai	10778, 10865, 10876
I	Iberia	10037
	ICE	10037, 10264, 10218, 10217, 10371
	ICeS	10218
	iDEAL	11556
	Iiyama	10877, 11217
	Imperial	10037, 10370, 10074, 10418
	Indiana	10037
	InFocus	11164, 11206
	Ingelen	10714, 10610, 10487, 10163

	Ingersol	10009
	Inno Hit	10218, 10009, 10217
	Innowert	10865, 11298
	Inteq	10017
	Interbuy	10037, 10264, 10009
	Interfunk	10037, 10361, 10109, 10163, 10200, 10327, 10512
	Internal	10556
	Intervision	10037, 10486, 10487, 10264, 10218, 10455, 10009, 10217, 10394
	Irradio	10037, 10218, 10009, 10371
	Isukai	10037, 10218, 10455
	ITC	10217
	ITS	10037, 10264, 10218, 10371
	ITT	10548, 10610, 10361, 10163, 10208, 10346, 10480
	ITT Nokia	10548, 10195, 10610, 10606, 10361, 10070, 10163, 10208, 10346, 10480
	ITV	10037, 10264, 10374
J	JCB	10000
	JDV	11982
	Jean	10036
	JEC	10035
	JMB	10556, 10634, 10443, 10499
	Jocel	10712
	Jubilee	10556
	JVC	10606, 10218, 10036, 10650, 10653, 11428, 11253, 10731, 10683, 10418, 10371, 10054, 10053, 10030
	Kaisui	10037, 10218, 10455, 10009, 10217
	Kapsch	10361, 10163
	Karcher	10714, 10610, 10606, 10264, 10370, 10778, 11556, 11982
	Kathrein	10556, 10880
	Kawa	10371
	Kawasho	10030
	KB Aristocrat	10163
	KEC	10060
	Kendo	10037, 11037, 10610, 10370, 11137, 10362, 10648, 11149
	Kennedy	10163
	Kennex	11037
	Kenwood	10030
	Keymat	11504
	Khind	10661
	Kioto	10706
	Kiton	10037, 10668
	Kneissel	10556, 10037, 10610, 10370, 10362, 10374, 10499
	Kolin	11240, 11331, 11610
	Kolster	10037, 10218
	Konig	10037
	Konka	10037, 10714, 10218, 10371, 10418, 10641

	Kontakt	10487
	Korpel	10037
	Korting	10370
	Kosmos	10037
	Koyoda	10009
	Kreisen	10876
	KTV	10030, 10217
	Kyoshu	10418
	Kyoto	10163, 10217
L	L&S Electronic	10714, 10808, 10865
	LaSAT	10486
	Lavis	11037
	Leader	10009
	Lecson	10037
	Lenco	10037, 10374
	Lenoir	10009
	Lexsor	11196
	Leyco	10037, 10264
	LG	10556, 10037, 10714, 10715, 10698, 10361, 10370, 10856, 11178, 11423, 11637, 11768, 10217, 10178, 10163, 10030, 10017, 10009, 10001
	Liesenk & Tter	10037
	Liesenkotter	10037, 10327
	Lifetec	10037, 10714, 10668, 11037, 11137, 10218, 10009, 10374, 10683
	Lloyd's	10009
	Local India TV	10009, 10208, 10602
	Lodos	11037, 11149
	Loewe	10037, 10370, 10512, 10633, 10790
	Logik	11037, 10001, 10011, 10773, 10880, 11217
	Logix	10668
	Luker	11982
	Luma	11037, 10009, 10163, 10362, 10374
	Lumatron	10037, 10264, 10073, 10163, 10217, 11937
	Lux May	10037, 10009
	Luxor	10548, 11037, 10361, 10163, 10208, 10217, 10346, 10480, 10631
	LXI	10047, 10054, 10154, 10156
	M Electronic	10037, 10714, 10634, 10195, 10361, 10009, 10109, 10163, 10217, 10287, 10343, 10346, 10374, 10480, 10512, 10661
	Madison	10037
	MAG	11498
	Magnadyne	10054, 10163
	Magnafon	10073
	Magnavox	10036, 10011, 10030, 10054, 11454, 11866, 11944
	Magnum	10037, 10714, 10715, 10648
	Mandor	10264

Manesth	10037, 10264, 10035, 10217
Manhattan	10037, 10668, 11037, 10778, 10876, 11267
Marantz	10556, 10037, 10030, 10054, 10704
Mark	10037, 10714, 10715, 10009, 10217, 10374
Mascom	11556
Master's	10499
Masuda	10218
Matsui	10556, 10037, 10714, 10195, 11037, 10487, 10036, 10455, 10433, 10880, 10744, 10443, 10371, 10352, 10335, 10217, 10208, 10163, 10035, 10011, 10009
Matsushita	10650, 10051
Maxent	11755
Maxim	11556, 11982
Medialine	11206
Mediator	10556, 10037
Medion	10556, 10037, 10714, 10668, 11037, 10698, 11137, 11556, 11248, 11149, 10880, 10808, 10512
Megas	10610
Megatron	10145, 10178
MEI	11037
Memorex	10037, 11037, 10009, 10030, 10060, 10150, 10154, 10178
Memphis	10009
Mercury	10037, 10009
Metronic	10625
Metz	10037, 10668, 10195, 10367, 10388, 10447, 10746
MGA	10030, 10150, 10178
Micromaxx	10037, 10668, 11037, 10808
Microstar	10808
Midland	10017, 10047, 10051
Mikomi	11037, 10744, 11149
Minato	10037
Minerva	10195, 10487, 10108, 10070
Minoka	10037
Mirai	12072
Mitsai	11556
Mitsubishi	10556, 10037, 11037, 10036, 10108, 10011, 10150, 10178, 10512
Mivar	10217
Monaco	10009
Morgan's	10037
MTC	10370, 10011, 10030, 10060, 10092, 10512
MTlogic	10714
Multitec	10037, 10668, 11037, 10486, 11556
Multitech	10037, 10486, 10264, 10370, 10009, 10217
Murphy	10163

N

Musikland	10218
Mx Onda	11498
Myryad	10556
NAD	10037, 10361, 10865
Naiko	10037, 10606, 11982
Nakimura	10037, 10374
Narita	11982
NAT	10226
National	10226
NEC	10036, 10009, 10011, 10030, 10053, 10170, 10217, 10374, 10704, 11270, 11704, 11797
Neckermann	10556, 10037, 10370, 10200, 10327, 10418
NEI	10037, 11037, 10163, 10371
Neon	11267
Neovia	10865, 10876, 11206, 11371
Netsat	10037
Neufunk	10556, 10037, 10714, 10610, 10218, 10009
New Tech	10556, 10037, 10009, 10217, 10343
New World	10218
Nikkai	10037, 10264, 10218, 10036, 10009, 10035, 10163, 10217
Nikkei	10714
Nikko	10178
Noblisko	10070
Nogamatic	10109
Nokia	10548, 10610, 10606, 10361, 10163, 10208, 10346, 10374, 10480, 10631
Nordic	10217
Nordmende	10037, 10714, 10560, 10195, 10109, 10287, 10343
Normerel	10037
Northern Star	11206
Novatronic	10037, 10374
NTC	10092
NuVision	11657
Oceanic	10548, 10361, 10163, 10208
Odeon	10264
Okano	10037, 10264, 10370, 10009
Olevia	11144, 11240, 11331, 11610
Omega	10264
Onida	10053, 11253
Onimax	10714
Onwa	10218, 10433, 10371, 10602
Opera	10037
Optimus	10650, 10166
Orbit	10037
Orcom	11504
Orion	10556, 10037, 10714, 11037, 10011, 10443, 10880, 11196
Online	10037, 10218
Ormond	10668, 11037

O

P

Osaki	10556, 10037, 10264, 10218, 10217, 10374
Osio	10037
Oso	10218
Osume	10037, 10218, 10036
Otic	11498
Otto Versand	10556, 10037, 10195, 10361, 10036, 10226, 10109, 10217, 10343, 10512
Pacific	10556, 10714, 11037, 11137, 10443
Palladium	10556, 10037, 10714, 10370, 11137, 10163, 10200, 10217, 10327, 10418, 11982
Palsonic	10037, 10698, 10264, 10001, 10217, 10418, 11196, 11269
Panama	10037, 10264, 10009, 10217
Panasonic	10037, 10548, 10361, 10650, 10226, 11480, 11310, 11291, 11271, 10853, 10367, 10163, 10156, 10054, 10051, 10035, 10030, 10000
Panavision	10037
Pathe Cinema	10163
Pathe Marconi	10109
Pausa	10009
Penney	10030, 10047, 10051, 10060, 10156, 10178, 11347
Perdio	10037, 10163
Perfekt	10037
Petters	10037
Philco	10037, 10370, 10054, 10074, 10145, 10418, 11661
Philharmonic	10217
Philips	10556, 10037, 10361, 11756, 11744, 11454, 11254, 10690, 10374, 10343, 10200, 10054, 10017, 10009, 10000
Phocus	10714
Phoenix	10037, 10486, 10370, 10163
Phonola	10556, 10037
Pilot	10706, 10030
Pioneer	10037, 10486, 10361, 10370, 11457, 11260, 11247, 10866, 10760, 10679, 10512, 10287, 10166, 10163, 10109
Pionier	10486, 10370, 11556
Plantron	10037, 10264, 10009
Play	11267
Playsonic	10037, 10714, 10715, 10217
Polaroid	11498, 11523, 12120
Poppy	10009
Portland	10092, 10374
Powerpoint	10037, 10698, 10487
Prandoni-Prince	10361
Precision	10217
Prima	10264, 10009, 11196, 11269
Princeton	11037, 10715
Prinz	10361
Prism	10051

Q

R

Profex	10361, 10009, 10163
Profi	10009
Profilo	11556
Profitronic	10037
Proline	10037, 10625, 10634, 11037, 10073
Proscan	10047
Proscoc	10156
Prosonic	10037, 10714, 10668, 10370, 10217, 10371, 10374
Protec	10037, 10264, 10009, 10217
Protech	10037, 10668, 11037, 10486, 10264, 10009, 10217, 10418
Proton	10178
ProVision	10556, 10037, 10714
Pulsar	10017
Pvision	10876
Pye	10556, 10037, 10374
Pymi	10009
Quadral	10218, 10051
Quasar	10009, 10051, 10865
Quelle	10037, 10668, 10195, 11037, 10361, 10011, 10070, 10074, 10109, 10200, 10327, 10512
Questa	10036
Questar	10036
R-Line	10037
Radialva	10218, 10163
Radiola	10556, 10037, 10217
Radiomarelli	10037
RadioShack	10037, 10030, 10047, 10154, 10178
Radiotone	10037, 10668, 11037, 10264, 10370, 10009, 10418, 10648
Rank	10070
Rank Arena	10036
RBM	10070
RCA	10625, 10047, 10051, 10090, 11147, 11247, 11347, 11781
Realistic	10030, 10154
RealiTV	11267
Reality	11267
Recor	10037
Rectiligne	10037
Reddiffusion	10548, 10361, 10036, 10163, 10346
Redstar	10037
Reflex	10037, 10668, 11037
Relisys	10865, 10876, 10877, 10878, 11206, 11207
Remotec	10037, 10145, 10171
Reoc	10714
Revox	10037
Rex	10264, 10163
RFT	10037, 10264

S

Roadstar	10037, 10714, 10668, 11037, 10715, 10264, 10218, 10009, 10418
Rolson	10819, 11371
Rover	10877
Royal Lux	10370, 10335
Runco	10017
Saba	10625, 10548, 10714, 10560, 10361, 10109, 10163, 10287, 10335, 10343, 10498
Sagem	10610, 10455
Saisho	10264, 10009, 10011, 10163, 10217
Saivod	10037, 10668, 11037, 10712, 11556, 11982
Sakai	10163
Salora	10548, 10361, 10163, 10208, 10480, 10631, 11556
Salsa	10335
Sampo	11755
Samsung	10556, 10037, 10264, 10370, 10618, 10702, 10718, 10766, 10812, 10814, 11060, 10371, 10217, 10208, 10178, 10163, 10090, 10060, 10035, 10030, 10009
Sandra	10217
Sansui	10037, 10706, 10861, 11371
Santon	10009
Sanyo	10037, 11037, 10370, 10036, 10108, 10000, 10009, 10011, 10047, 10154, 10163, 10170, 10208, 10217, 10704, 11208
Sanyong	10037
SBR	10556, 10037
Schaub Lorenz	10548, 10714, 10486, 10606, 10361, 10374, 11371
Schneider	10556, 10037, 10714, 10668, 11037, 10361, 11137, 10218, 11982, 10648, 10394, 10371, 10352, 10343, 10217, 10163, 10070
Scotch	10178
Scotland	10163
Scott	11711
Sears	10047, 10054, 10154, 10156, 10171, 10178
Seaway	10634
Seelver	11037
SEG	10037, 10668, 11037, 10487, 10264, 10218, 10036, 10009, 10217, 10362, 11149
SEI	10037, 10163
Sei-Sinudyne	10037
Seleco	10163, 10346, 10362, 10371
Semp	10156
Sencora	10009
Sentra	10035
Serino	10610, 10455
Sharp	10036, 10653, 11193, 10053, 10200, 10818, 11393

Shintoshi	10037
Shivaki	10037, 10443
Siarem	10163
Siemens	10037, 10195, 10145, 10200, 10327
Siera	10556, 10037
Siesta	10370
Silva	10037, 10361, 10648
Silva Schneider	10037, 11556, 11982
Silver	10715, 10361, 10036
SilverCrest	11037
Singer	10037, 10433, 10009, 10335
Sinotec	10773
Sinudyne	10037, 10361, 10163
Skantic	10163
SKY	10037, 10880, 11504
SKY Brazil	10880
Sliding	10865, 10880
SLX	10668
Smaragd	10487
Soemtron	10865, 11298
Sogo	10606
Solar Drape	10000
Solavox	10037, 10548, 10361, 10163
Sonawa	10218
Soniko	10037
Sonitron	10370, 10208, 10217
Sonneclair	10037
Sonoko	10037, 10264, 10009, 10217
Sonorol	10548, 10361, 10163, 10208
Sontec	10037, 10370, 10009
Sony	10037, 11505, 10036, 11751, 11685, 11651, [10810]* , 10353, 10154, 10150, 10074, 10053, 10011, 10000
Sound & Vision	10218, 10374
Soundesign	10178
Soundwave	10037, 11037, 10715, 10418
Soyo	11834
Spectra	10009
Squareview	10171
Ssangyong	10009
Standard	10037, 11037, 10218, 10009, 10217, 10374
Standard Components	10218, 10009
Starlite	10037, 10264, 10009, 10163
Stenway	10218
Stern	10264, 10163
Strato	10037, 10264, 10009
Strong	11149
Stylandia	10217
Sunkai	10610, 10487, 10218, 10455, 10865
Sunstar	10037, 10264, 10009, 10371

Sunwood	10037
Superla	10217
SuperTech	10556, 10037, 10218, 10009
Supra	10009, 10374
Supreme	10000
Susumu	10218, 10287, 10335
Sutron	10009
SVA	10865
Swisstec	10865, 10880, 11504
Sydney	10217
Sylvania	10030, 10054, 10171, 11394, 11864
Symphonic	10171
Syntax	11144, 11240, 11331
Sysline	10037
T+A	10447
Tandberg	10361, 10109, 10367
Tandy	10218, 10163, 10217
Targa	11267, 11371
Tashiko	10036, 10163, 10170, 10217
Tatung	10037, 10011, 10217, 11248, 11371, 11556, 11756
TCL	10706
TCM	10714, 10808
Teac	10037, 10714, 10668, 10698, 10712, 10264, 10455, 10009, 10170, 10171, 10178, 10512
Tec	10037, 10009, 10163, 10217, 10335
Tech Line	10037, 10668
Techica	10218
Technica	11037, 11982
Technics	10556, 10650, 10051
TechniSat	10556, 11267
Technisson	10714
Technosonic	10556, 10625, 10499, 10880, 11982
Techwood	11037, 10051
Tecnimagen	10556
Teco	11040, 11523
Tedelex	10009, 10217
Teiron	10009
Teknika	10054, 10060, 10092
TELE System	10876
Teleavia	10287, 10343
Telecor	10037, 10218, 10163, 10217, 10394
Telefunken	10037, 10625, 10714, 10560, 10486, 10073, 10074, 10109, 10287, 10335, 10343, 10346, 10498, 10702
Telefusion	10037
Telegazi	10037, 10264, 10218, 10163
Telemeister	10037
Telesonic	10037
Telestar	10556, 10037

Teletech	10037, 10668, 11037, 10009
Teleton	10036, 10217
Televideon	10163
Televue	10037
Tempest	10009
Tennessee	10037
Tensai	10037, 11037, 10715, 10218, 10009, 10217, 10371, 10374
Tenson	10009
Tevion	10556, 10037, 10714, 10668, 11037, 11137, 10648, 10808, 11248, 11298, 11498, 11556
Textet	10218, 10009, 10217, 10374
Texla	10780
ThemeScene	10887
Thomson	10037, 10625, 10560, 10109, 10287, 10335, 10343, 11447
Thorn	10037, 10361, 10264, 10036, 10035, 10073, 10074, 10109, 10163, 10335, 10343, 10499, 10512
Thorn-Ferguson	10073, 10335, 10343, 10499
Tiny	11269
TMK	10178
Tokai	10037, 10668, 11037, 10009, 10163, 10217, 10374
Tokaido	11037
Tokyo	10035
Tomashi	10218
Topline	10668, 11037
Toshiba	10195, 11037, 10264, 10036, 10618, 10650, 10508, 11356, 11508, 11524, 11656, 12203, 11256, 11164, 11156, 10718, 10156, 10154, 10109, 10070, 10060, 10035
Tosumi	11982
Towada	10217
Toyoda	10009
Trakton	10264
TRANS-continents	10556, 10037, 10668, 11037, 10217, 10865
Transonic	10037, 10009
Trident	10217
Trio	11498
Tristar	10264, 10218
Triumph	10556, 10037, 10346
TVTEXT 95	10556
Uher	10037, 10486, 10370, 10374, 10418, 10480
Ultravox	10037, 10163, 10374
Unic Line	10037, 10455
United	10556, 10037, 10714, 11037, 10715, 11982
Universal	10037

Universum	10037, 10668, 10195, 11037, 10361, 10264, 10370, 10036, 10618, 10808, 10631, 10512, 10480, 10418, 10362, 10346, 10327, 10217, 10200, 10170, 10109, 10074, 10070, 10011, 10009
Univox	10037, 10163
V2max	10865
V7 Videoseven	10880, 11217, 11267, 11755
Vector Research	10030
Vestel	10037, 10668, 11037, 10217
Vexa	10037, 10009
Victor	10036, 10053, 11428
Videocon	10508
Videologic	10218
Videologique	10218, 10217
VideoSystem	10037
Videotechnic	10217, 10374
Videoton	10163
Vidikron	10054
Vidtech	10178
Viewpia	10876
Viewsonic	11627, 11755
Vision	10037, 10217
Vistron	11363
Vizio	11758
Vortec	10037
Voxson	10037, 10163, 10418
Waltham	10037, 10668, 11037, 10109, 10217, 10418, 10443
Wards	10000, 10017, 10030, 10047, 10051, 10054, 10060, 10154, 10156, 10166, 10178, 11147, 11347
Watson	10037, 10714, 10668, 11037, 10218, 10009, 10163, 10394
Watt Radio	10163
Wega	10037, 10036
Wegavox	10009
Welltech	10714
Weltblick	10217
Weltstar	11037
Westinghouse	10885, 10889
Wharfedale	10556, 10037, 11556
White Westinghouse	10037, 10623
Wilson	10556
Windsor	10668, 11037
Windy Sam	10556
World-of-Vision	10865, 10877, 10880, 11217, 11298
Xenius	10634, 10661
Xoro	11196, 11217
Xrypton	10037
Yamaha	10030, 11576
Yamishi	10037, 10218, 10455, 10217

Yokan	10037
Yoko	10037, 10264, 10370, 10218, 10009, 10217
Yorx	10218
Zanussi	10163, 10217
Zenith	10017

Television/DVD Combination

A Akai	11675
Akura	31367
Akura	11982
Alba	30695, 30884
Amstrad	31367
Amstrad	11982
Audiovox	11951
Axion	11958
B Black Diamond	30713, 30884
Black Diamond	11037
Blue Sky	30713, 30884
Blue Sky	11037
Bush	30713, 30884, 31367
Bush	11037, 10698, 11556, 11900, 11982
C Centrum	30713
Centrum	11037
Crown	30713
Crown	11037
D DMTech	31271
DMTech	11937
Dual	30713, 30884
Dual	11037
D-Vision	31367
D-Vision	11982
E Elfunk	30713, 30884
Elfunk	11037
F Ferguson	30695, 30713, 30884
Ferguson	11037
Finlux	11556
G Goodmans	30713
Goodmans	11037, 11900
Grandin	30713
Grundig	30539, 30695
H Hitachi	30713, 30884
Hitachi	11037
J JDV	31367
JDV	11982
K Karcher	31367
Karcher	11982
Kotron	11900
L Logik	30713, 30884
Logik	11037
Luker	31367

Luker	11982
Luxor	30713, 30884
Luxor	11037
M Matsui	30713, 30884
Matsui	11037
Maxim	31367
Maxim	11982
Medialine	31271
Medion	11900
Mirror	11900
N Naiko	31367
Naiko	11982
Narita	31367
Narita	11982
Neovia	31271
O Orion	30695
P Palladium	31367
Palladium	11982
Philips	30539, 30854
Philips	10556, 11454
Polaroid	11523
Powerpoint	10698
R Roadstar	11900
S Saivod	31367
Saivod	11982
Samsung	30899
Samsung	11903
Schneider	31367
Schneider	11982
SEG	30713, 30884
SEG	11037
Silva Schneider	31367
Silva Schneider	11982
Sliding	31115
Sylvania	32194
Sylvania	11864
T Technica	30713, 30884, 31367
Technica	11037, 11982
Technosonic	31367
Technosonic	11982
Teletech	30713, 30884
Teletech	11037
Thomson	30551
Thomson	10625
Toshiba	30695
Tosumi	31367
Tosumi	11982
U United	30713, 30884, 31367
United	11037, 11982
Universum	30713
V Vestel	30884
Vestel	11037

W Weltstar	30713
Weltstar	11037
Wharfedale	31115

Television/DVD/Video deck Combination

A Akai	30899
Akai	11903
F Ferguson	30695
M Magnavox	30821
Magnavox	11944
Matsui	30695

Television/Video deck Combination

A Aiwa	20742, 21137
Aiwa	11904
Amstrad	10171
B Beko	10486
Bestar	20278
Black Diamond	11909
Blue Sky	20278, 20742
Broksonic	20742
Broksonic	11911
Bush	20742
C Citizen	20278
Curtis Mathes	10051
D Daewoo	20278
Daewoo	11909
Dantax	20742
E Emerson	20278
Emerson	11909, 11911
F Ferguson	20278, 20742
Ferguson	10625, 10073
Fidelity	10171
Firstline	20278
Funai	20593
Funai	11904
G GE	20048, 20060, 20240
GE	10047, 10051, 11917, 11922
GoldStar	20037
GoldStar	10037
Goodmans	20278, 20742
Goodmans	11909, 10374
Grandin	20278, 20742
Grundig	20081, 20742
Grundig	10556, 10037, 10195
H Harley Davidson	11904
Hinari	10036

Hitachi	11904
Hypson	20037
I Internal	20278
Internal	11909
J JBL	20278
K Kneissel	20278
L LG	20037
LG	10178
Lloyd's	11904
M Magnasonic	20278, 20593
Magnavox	20081
Magnavox	10054, 11904
Magnin	20240
Matsui	20742
Memorex	20037
MGA	20240
Mitsubishi	20081, 20048
Mitsubishi	10556, 11917
O Orion	20742
Orion	11911
P Pacific	20742
Panasonic	21162
Panasonic	10051
Penney	20037, 20240
Penney	10051
Philips	20081
Philips	10556, 10037
Q Quasar	10051
R Radiola	20081
Radiola	10556
RCA	20048, 20060, 20240
RCA	10047, 10051, 11917, 11922
S Saba	10625
Samsung	20240, 20742
Sansui	11904, 11911
Sanyo	20240
Schneider	20081
Schneider	10556, 10037, 11904
Sears	20037
Sears	11904
Sharp	20048
Sharp	11917
Siemens	20081
Siemens	10037
Sony	20032
Sony	11505, 10000, 11904
Sylvania	20081
Sylvania	10054
Symphonic	11904
T Teac	10171
Technics	20081
Technics	10556

Telefunken	20278
Telefunken	10074
Thomas	11904
Thomson	20278
Thomson	10625
Toshiba	20742
U United	20742
W White Westinghouse	20278
Z Zenith	11904

Satellite Set Top Box

A @sat	01300
@Sky	01334
A-Mark	00345
ABsat	00123, 00713
Acoustic Solutions	01284
ADB	01367, 01418, 01473, 01491
AGS	00710
Airis	01993
Akai	00200
Akura	01705
Alba	00455, 00713, 01284, 01659, 01811
Allsat	00200, 01043
Alltech	00713
Allvision	01232, 01334, 01412
Amitronica	00713
Amstrad	00847, 01175, 00345, 00713, 00795, 00863, 00882, 01113, 01693, 01801
Anglo	00713
Ankaro	00713
AntSat	01083
Apollo	00455
Apro	01672
Arcon	01043, 01075
Armstrong	00200
Amion	01300
ASA	00740
Asat	00200
ASCI	01334
ASLF	00713
AssCom	00853
Astacom	00710
Aston	00142
Astra	00713
Astratec	01743
Astro	00173, 00658, 01099, 01100, 01113
Atlantic Telephone	01333
Atsat	01300
AtSky	01334

Audioline	01672
Austar	00497, 00863
Axiel	00710
Axil	01413, 01457, 01659, 01993
Axis	01111
Axitronic	01626
B B@ytronic	00740, 01412
Balmet	01457
Beko	00455
Belson	01695
Best Buy	01993
Big Sat	01457
Black Diamond	01284
Blaupunkt	00173
Blue Sky	00713
Boca	00713, 01232, 01366, 02026
Boshmann	01413, 01631
Boston	00710, 01251
Brainwave	00658, 01672
British Sky Broadcasting	00847, 01175, 01662, 01847
Broco	00713
BskyB	00847, 01175, 01662
BT	00710, 01296
Bubu Sat	00713
Bush	01284, 01291, 01645, 01672, 01743, 01811
C Canal Digital	00853, 01780
Canal Satellite	00853, 01339
Canal+	00853
CGV	01413, 01567
Chaparral	00216
Cherokee	00123, 00710
Chess	00713, 01085, 01334, 01626, 02026
Chili	01718
CityCom	00299, 00394, 00658, 00818, 01075, 01176, 01232
Classic	01672
Clatronic	01413
Clayton	01626
Comag	00339, 01232, 01366, 01412, 01413, 02026
Comsat	01413
Condor	01700
Contec	00394
Continental Edison	01695
Coship	01457, 01672
Crown	01284
Cryptovision	00455, 00795
CS	01631
Cyfra+	01076
Cyrus	00200
D D-box	01127, 00723, 01114, 00873

Daewoo	01111, 00713, 01296, 01743
DAK	01993
Dantax	01626
Delfa	00863
Deltasat	01075
Digenius	00299
Digitality	01334, 01685
Digifusion	01645, 01743
Digihome	01284
DigiLogic	01284
DigiQuest	00863, 01300, 01457, 01473, 01631
DigiSat	01232
Digisky	01457
DigitalBox	01100, 01631
DigitAll World	01227
Digittrade	01659
Digiturk	01076
Dijam	01296
Dilog	01780, 01957
DiPro	01367, 01543
DirecTV	00099, [01377]*
Discovery	00710
Dish Network System	00775
Distratel	01283, 01704, 01705
DMT	01075
DNT	00200
Dream Multimedia	01237, 01652
DSTV	01433
Durabrand	01284
E Echolink	01366
Echostar	00853, 00610, 01200, 00455, 00713, 00775, 00871, 01086, 01323, 01409, 01418, 01473
Edision	01631
Einhell	00713
Elap	00713, 01413, 01567
Elless	00740
Elsat	00713
Elta	00200, 01659
Emme Esse	00871
eMTech	01214
Energy Sistem	01631
Engel	00713, 01251, 01801, 01993
EP Sat	00455
Eurieult	00882
Eurocrypt	00455
EuroLine	01251
Europa	00863
Europhon	00299
Eurosky	00262, 00299, 00740
Eurostar	00818
Eutelsat	00713

Eutra	00740
Expressvu	00775
F Fenner	00713
Ferguson	00455, 01291, 01743
Finepass	01780
Finlandia	00455
Finlux	00455, 01626
FinnSat	00740, 01994
Flair Mate	00713
Fly Com	01457
FMD	01413, 01457
Force	01101
Fortec Star	01083
Foxtel	00497
Fracarro	00125, 00871
Freesat	00882
FTE	00863
FTEmaximal	00713, 00863
Fuba	00173, 00262, 00299, 00394, 01214, 01251, 01801
Fugionkyo	00125
G Galaxis	00853, 01111, 00863, 01101, 01557
Gardiner	00818
Garnet	01075
GbSAT	01214
Gecco	01412
General Instrument	00869
General Satellite	01176
GF Good Friends	01043
GF Star	01043
Globo	00339, 00740, 01251, 01334, 01412, 01429, 01626, 02026
GOD Digital	00200
Gold Box	00853
Gold Vision	01631
Golden Interstar	01283
GoldStar	00394
Goodmans	00455, 01284, 01291, 01591, 01705
Gradiente	00887
Gran Prix	00740
Granada	00455
Grandin	01626
Grocos	01409, 01457
Grundig	00847, 00853, 00173, 00345, 01284, 01291, 01659, 01672, 01780
H Hama	01567
Handan	01780, 01957
Hanseatic	01099, 01100
Hauppauge	01672
HB	01214, 01801
HDT	01159

Hirschmann	01111, 00173, 00125, 00299, 00442, 00710, 00740, 00882, 01085, 01232, 01412
Hitachi	00455, 01250, 01284
Homecast	01680
Hornet	01300
HTS	00775
Hughes Network Systems	00749
Humax	01915, 01808, 01743, 01427, 01225, 01176, 00863
Huth	01075
Hyundai	01075, 01159
I i-CAN	01367
ID Digital	01176
ILLUSION sat	01557, 01631
Imperial	01195, 01197, 01334, 01429, 01631, 01672
Ingelen	00882
Inno Hit	01626
Interstar	01214
Inves	01743, 01993
InVideo	00871
iotronic	01413
Italtel	00871
ITT Nokia	00723, 00873, 00455
J Jaeger	01334
JOK	00710
JVC	00775
K K-SAT	00713
Kamm	00713
Kaon	01300
KaTelco	01111
Kathrein	00173, 00200, 01717, 01567, 01561, 01416, 00818, 00713, 00707, 00658, 00504, 00480, 00442, 00394, 00249, 00123
Kennex	00125
Kenwood	00853
Klap	00710
Kocmoc TB	01333
Koscom	01043
Kosmos	00442, 01333
Kreiling	00658, 01626
Kreiselmeier	00173
L L&S Electronic	01043, 01334
Labgear	01296
LaSAT	00173, 00299, 00740
Legend	01718
Leiko	01626
Lemon	01334
Lenco	00713
LG	01075
Lifesat	00299, 00713, 01043
Listo	01626

Lodos	01284
Logik	01284
Logix	01075
Lorenzen	00299
Luxor	00873, 00345
M M Electronic	00818
M vision	01557
Manata	00710, 00713
Manhattan	00455, 00710, 01083, 01300
Marantz	00200
Maspro	00173, 00713
Master's	00394
Matsui	00173, 00710, 01284, 01591, 01626, 01743
Maxim	01705
Maximum	01075, 01334, 01685
MDS	01225
Mediabox	00853
MediaSat	00853, 01339
Medion	02026, 01994, 01626, 01412, 01334, 01232, 01075, 01043, 00740, 00713, 00299
Medison	00713
Mega	00200
Metronic	00713, 00818, 01283, 01334, 01375, 01413, 01659, 01704, 01705
Metz	00173
MiCO	01811, 01993
Micro	00713
Micro Elektronik	00713
Micro Technology	00713
Micromaxx	00299
Microstar	00299, 01075
Microtec	00713
Mitsubishi	00455
Morgan's	00200, 00713, 01232, 01412
Motorola	01473
Multichoice	01333, 01433
Mustek	01659
Mx Onda	01659
Myryad	00200
Mysat	00713
MySky	01693, 01848, 01850
N Neom	01993
NEOTION	01334
Netgem	01322
Netsat	00887, 00099
Neuf TV	01322
Neuhaus	00713
Neuling	01232
Neusat	00713
Nevir	01659
Next Level	00869

Nikko	00723, 00200, 00713
Noda Electronic	01704, 01705
Nokia	01127, 00853, 00723, 00873, 00455, 01023, 01223, 01723
Nordmende	00455
O OctalTV	01505
Oggle	01705
Okano	00442
Onn	01284
Opentel	01232, 01412
Optex	00394, 00713, 01043, 01283, 01413, 01611, 01626
Orbis	01232, 01334, 01412
Orbitech	01099, 01100, 01195, 01197
Origo	00497
OSAT	00345
P P/Sat	01232
Pace	00847, 00853, 00200, 00887, 01175, 01850, 01848, 01717, 01693, 01423, 01323, 00795, 00497, 00455, 00329
Pacific	01284, 01375
Packard Bell	01111
Packsat	00710
Palcom	00299, 01409
Panasat	00615, 01333, 01433
Panasonic	00847, 00455, 00701, 01304
Panda	00173, 00455
Pass	01567
Patriot	00710
peekTon	01457, 01659, 01993
Philips	00853, 00173, 00200, 01114, 00099, 00455, 00710, 00818, 01076, 01533, 01543, 01672, 01743
Phonotrend	01200, 00863, 01780
Pilotime	01339
Pino	01334
Pioneer	00853, 00329, 01308
Planet	00871
Plasmatic	00442
PMB	00713, 01611
Polytron	00394
Portland	01296
Preisner	00262, 01101, 01113, 01366
Premier	00723, 00873, 01429
Prima	00795
Primacom	01111
Pro Basic	00853, 02205
Profile	00710
Proline	01284, 01659
Promax	00455
Proscan	00392
Q Quadral	00710
Quelle	00299

R	Radiola	00200
	Radix	00394, 00882, 01113, 01317
	RCA	00143, 00392, 00566
	Rebox	01214
	Regal	01251
	RFT	00200
	Roadstar	00853, 00713
	Rollmaster	01413
	Rover	00713
	Rownsonic	01567
S	SAB	01251, 01300
	Saba	00820, 00710, 00740, 02205
	Sabre	00455
	Sagem	00820, 01114, 01253, 01690, 01692
	Salora	01232
	Samsung	00853, 01175, 01458, 01570, 01700, 01916
	Sansui	01545
	Sanyo	01626
	Sat Control	01300
	Sat Team	00713
	SAT+	01409
	Satec	00713
	Satelco	01232
	Satplus	01100
	Satstation	01083
	SatyCon	01631
	Schaub Lorenz	01214
	Schneider	00710, 01251
	Schwaiger	01111, 01672, 01631, 01457, 01429, 01412, 01334, 01317, 01083, 01075, 00863, 00740, 00504, 00394
	SCS	00299, 00740
	Sedea Electronique	00125, 01283, 01626
	Seeltech	01993
	SEG	01075, 01087, 01251, 01284, 01626, 01993
	Seleco	00871
	Septimo	01375
	Serd	01412
	Serino	00610
	Servimat	01611
	ServiSat	00713, 01251
	Shark	01631
	Siemens	00173, 01334, 01429, 01657
	Silva	00299
	SilverCrest	02026
	Skantin	00713
	SKR	00713
	SKY	00847, 00887, 01175, 00099, 01662, 01693, 01847, 01848, 01850
	SKY Italia	00853, 01693, 01847, 01848

	Sky Television	01014
	Sky XL	01251, 01412
	Sky+	01175
	Skymaster	01200, 00713, 01075, 01085, 01334, 01409, 01545, 01567, 01611, 02205
	Skymax	00200, 01413
	Skypex	00740
	Skyplus	01175, 00339, 00740, 01232, 01334, 01412, 02026
	SkySat	00713
	Skyvision	01334
	SL	00299, 00339, 00740, 01672, 02026
	SM Electronic	01200, 00713, 01409
	Smart	00713, 00882, 01101, 01113, 01232, 01404, 01413, 01631, 02099
	Sony	00847, 00853, 00455, 00639, 01558
	Star Choice	00869
	Star Sat	01214
	Starland	00713
	Starlite	00200
	Stream	01847, 01848
	Stream System	01300
	Strong	00853, 00820, 00125, 00713, 01159, 01284, 01409, 01473, 01626, 01765, 01801
	Sumin	01412
	Sunkai	00123
	Sunny	01300
	Sunsat	00713
	Sunstech	01993
	Supernova	00887
	Supratech	01413, 01993
	Systec	01334
T	Tahnon	01704
	Tantec	00455
	Tatung	00455
	TBoston	01251, 01659
	Tecatel	01200
	Technical	01626
	Technika	01284, 01672, 01705
	TechniSat	01322, 01197, 01195, 01100, 01099, 00863, 00455, 00262
	Technomate	01283, 01610
	Technosonic	01672
	Technotrend	01429, 01672
	Techwood	01284, 01626
	TELE System	01159, 01251, 01409, 01611, 01801
	Teleciel	01043
	TeleClub	01367
	Telefunken	00710
	Teleka	00262, 00442

	Telestar	01099, 01100, 01195, 01197, 01251, 01334, 01610, 01626, 01672
	Telesystem	01801
	Televes	00455, 01214, 01300, 01334
	Televisa	00887
	Telewire	01232
	Tevion	00713, 01409, 01672, 01705, 02205
	Thomson	00847, 00853, 00820, 01175, 01848, 01662, 01543, 01534, 01291, 01046, 00713, 00710, 00455, 00392
	Thorn	00455
	Tiny	01672
	Tioko	00394
	Titan	02205
	Tividi	01429
	Tokai	00200
	Tonna	00455, 00713, 01611
	Topfield	01208, 01545, 01824, 01986
	Toshiba	00455, 00749, 00790, 01284
	TPS	00820, 01253
	Trevi	01251
	Triax	00853, 00200, 00713, 01113, 01227, 01251, 01291, 01296, 01317, 01413, 01611, 01626, 01700
	TT-micro	01429
	Turnsat	00713
	Twiner	00713, 01611
U	Unisat	00200
	United	01251
	Universum	00173, 00299, 00740, 01087, 01099, 01251
V	Vaova	01993
	Variosat	00173
	Ventana	00200
	Vestel	01251, 01284
	VH Sat	00299
	Viasat	01682
	Viola Digital	01672
	Vision	01626
	Visionic	00125, 01283
	VisionNet	01557
	Visiosat	00142, 00710, 00713, 01413, 01457, 01718
	Vitecom	01413
	Vivid	01162
	VTech	00818
W	Wewa	00455
	Wharfedale	01284
	Winbox	01801
	Wisi	00173, 00299, 00455, 00740, 01232
	Worldsat	00123, 00710, 01214, 01251, 01543

X	Xcom	00123
	Xsat	00847, 00123, 00713, 01214, 01323
	Xtreme	01300
Y	Yakumo	01413
	Yamada	01718, 01993
	Yes	00887
Z	ZapMaster	00740
	Zehnder	00394, 00504, 00818, 01075, 01232, 01251, 01334, 01412, 01413, 01631
	Zeta Technology	00200
	Zodiac	01801

Cable Set Top Box

A	ABC	00003, 00008, 00237
	Austar	00276
B	Birmingham Cable Communications	00276
	British Telecom	00003
C	Cable & Wireless	01068
D	Daehan	00778
	Daeryung	00008
E	Encon	00008
F	Fosgate	00276
	France Telecom	00817
	Freebox	01482
G	Galaxi	00008
	GE	00237
	General Instrument	00276, 00003, 00476
J	Jerrold	00276, 00003, 00476
K	Kabelvision	00003
M	Macab	00817
	Matav	01082
	Melita	00003
	Motorola	00276
N	Noos	00817
	Nova Vision	00008
	NTL	01068, 01060, 00276, 00003
O	Ono	01068
	Optus	00276
	Orange	00817
P	Pace	01068, 01060, 00237, 01577
	Philips	00817
	Pioneer	00877
	PVP Stereo Visual Matrix	00003
S	Sagem	00817
	Samsung	01060, 00778, 01666, 02015
	Scientific Atlanta	00008, 00237, 00477, 00877
	Starcom	00003
	StarHub	00276
	Supercable	00276

T	Taihan	00778
	Telewest	01068
	Torx	00003
U	United Cable	00003
	US Electronics	00276
V	Virgin Media	01068, 01060
	Visiopass	00817

IPTV/HDTV Set Top Box

A	Acer	01272
	ADB	02586
	Amino	01481
	AT&T	00858
B	Belgacom TV	02345
D	Daily Media	01272
F	Fujitsu Siemens	01272
H	Hewlett Packard	01272
M	Microsoft	01272, 02049
P	Packard Bell	01272
	Philips	01272
R	Ricavision	01272
S	Scientific Atlanta	00858, 02345
	Sony	01272
	Sylvania	01563
V	VIA Technologies	01272
X	Xbox	02049

DVD preset codes DVD-Voreinstellungscodes Codes pré-réglés DVD Codici di preselezione DVD Códigos de preajuste de DVD DVD-voorkeuzecodes Förinställda DVD-koder Codes pré-réglés DVD	32134			30490
DENON				
Model No.	DVD-900	DVD-1920	DVD-3800	DVD-800
Modellnr	DVD-1000	DVD-1930	DVD-3910	DVD-1600
Modèle numéro	DVD-1400	DVD-1940	DVD-3930	DVD-2000
Modello No	DVD-1500	DVD-2200	DVD-A11	DVD-2500
Nº de modelo	DVD-1710	DVD-2800	DVD-5000	DVD-3000
Modelnr	DVD-1720	DVD-2800II	DVD-A1XV	DVD-3300
Modellnr	DVD-1730	DVD-2900	DVD-A1XVA	
	DVD-1740	DVD-2910	DVD-A1	
	DVD-1910	DVD-2930	DVM-3700	

Blu-ray preset codes Blu-ray-Voreinstellungscodes Codes pré-réglés Blu-ray Codici di preselezione Blu-ray Códigos de preajuste de Blu-ray Blu-ray-voorkeuzecodes Förinställda Blu-ray	32258		
DENON			
Model No.	DVD-1800BD		
Modellnr	DVD-2500BT		
Modèle numéro	DVD-3800BD		
Modello No	DVD-A1UD		
Nº de modelo			
Modelnr			
Modellnr			

[]*: Preset codes set upon shipment from the factory.
 : Sie Voreinstellungscodes wurden vor der Auslieferung werkseitig eingestellt.
 : Les codes pré-réglés diffèrent en fonction de la livraison de l'usine.
 : I codici di pre-settaggio sono impostati in fabbrica prima della consegna.
 : Los códigos vienen preprogramados de fábrica.
 : Vooringestelde codes bij het verlaten van de fabriek.
 : Förinställda koder har ställts in vid transporten från fabriken.

	DVD Player / DVD-Player / Lecteur DVD / Lettore DVD / Reproductor de DVD / DVD-speler / DVD-spelare DENON [32134]
	Video Cassette Recorder / Videokassettenrecorder / Magnétoscope / VCR (videoregistratore) / Videograbadora / Videocassetterecorder / Videobandspelare Tivo [20739]
	Television / Fernseher / Télévision / Televisione / Televisión / Televisie / Television SONY [10810]
	Satellite Set Top Box / Topbox für Satelliten einstellen / Réglage du boîtier pour satellite / Configurazione decoder satellitare / Configurar descodificador para satélite / Kastje met converter en decoder voor satelliet / Ställ in översta boxen för satellit DirecTV [01377]



The preset codes listed in this manual are only applicable to the region of purchase.
 Die in diesem Handbuch angegebenen Voreinstellungs-Codes gelten nur für die Verkaufsregion.
 Les codes de pré-réglage listés dans ce manuel ne sont applicables que dans la région de l'achat.
 I codici preprogrammati elencati nel presente manuale sono applicabili esclusivamente nella regione di acquisto del dispositivo.
 Los códigos predeterminados enumerados en este manual sólo son aplicables a la región de compra.
 De in dit handboek vermelde vooringestelde codes zijn alleen van toepassing op het aankoopgebied.
 De förinställda koderna som finns i den här manualen gäller endast för den region där produkten köptes.







DENON

www.denon.com

D&M Holdings Inc.
Printed in China 5411 10381 008DB