

**Early diagnosis and detection of eutypa  
dieback of grapevines**

**Richard Lardner**

**Thesis submitted for the degree of  
Doctor of Philosophy  
at  
The University of Adelaide**

**Discipline of Plant and Pest Science  
Faculty of Sciences**

**November 2003**

# Table of contents

Abstract	i
Declaration	iii
Acknowledgments	iv
Abbreviations	v
Chapter 1 General Introduction	1
1.1 Introduction	1
1.2 History of <i>Eutypa</i> as a pathogen	2
1.3 <i>Eutypa</i> dieback of grapevines	3
1.3.1 Host Pathogen Interactions	3
1.3.1.1 Disease cycle	3
1.3.2 Symptoms of <i>eutypa</i> dieback	5
1.3.2.1 Woody tissue symptoms	5
1.3.2.2 Foliar symptoms	6
1.3.3 Relative susceptibility of <i>V. vinifera</i> cultivars to <i>E. lata</i>	7
1.4 Control of <i>eutypa</i> dieback	7
1.5 Significance of the pathogen to the grape growing industry	8
1.6 Production of secondary metabolites by <i>E. lata</i>	10
1.7 Diagnosis of <i>eutypa</i> dieback	12
1.8 Early diagnosis of fungal plant pathogens	13
1.8.1 Immunological techniques	14
1.8.2 Isozyme analysis	15
1.8.3 Nucleic acid-based diagnosis	15
1.8.3.1 RFLP-based techniques	16
1.8.3.2 PCR-based generation of markers	17
1.8.3.3 Generation of species-specific primers for diagnostic purposes	19
1.8.4 Molecular analysis of <i>E. lata</i>	20
1.9 Spectroscopy	21
1.10 Summary and objectives	22
Chapter 2 General materials and methods	23
2.1 Collection and maintenance of <i>E. lata</i> isolates	23
2.2 Fungal isolates	24
2.3 Growth of isolates for DNA extraction	26
2.4 DNA extraction from fungal mycelium	26
2.5 Southern hybridisation	27
2.5.1 Southern transfer of genomic DNA to nylon membranes	27
2.5.2 Preparation and digestion of plasmid DNA	27
2.5.3 DNA hybridisation techniques	28
Chapter 3 Development of SCAR markers specific to <i>E. lata</i>	29
3.1 Introduction	29
3.2 Methods	31
3.2.1 RAPD amplification and primer selection	31
3.2.2 Cloning and characterisation of RAPD fragments	32
3.2.3 Primer design	34
3.2.4 Validation of SCAR markers	34
3.2.5 Assessment of SCAR and ITS markers developed in France and California	34
3.2.6 Genetic variation within <i>E. lata</i>	35

	3.2.6.1 Analysis of banding patterns	36
3.3	Results	36
	3.3.1 RAPD primer screening	36
	3.3.2 Cloning and sequencing of PCR products	39
	3.3.3 Sequence analysis	39
	3.3.4 Primer design	40
	3.3.5 Validation of SCAR markers	42
	3.3.6 Assessment of specificity of French PCR primers towards Australian isolates of <i>E. lata</i>	45
	3.3.7 Assessment of specificity of Californian ITS primers towards Australian isolates of <i>E. lata</i>	46
	3.3.8 Genetic variation within <i>E. lata</i>	48
3.4	Discussion	51
Chapter 4	Development of RFLP markers specific to <i>E. lata</i> .	55
4.1	Introduction	55
4.2	Materials and Methods	56
	4.2.1 Construction of genomic DNA library of <i>E. lata</i>	56
	4.2.1.1 Preparation of insert and vector DNA	56
	4.2.1.2 Ligation and transformation reactions	57
	4.2.1.3 Analysis of recombinant colonies for specificity to <i>E. lata</i>	58
	4.2.1.4 Storage of recombinant colonies	60
	4.2.2 Genetic variation within <i>E. lata</i>	60
	4.2.2.1 Data analysis	60
4.3	Results	60
	4.3.1 Analysis of <i>E. lata</i> genomic DNA library	60
	4.3.2 Analysis of recombinant colonies for specificity to <i>E. lata</i>	61
	4.3.3 Genetic variation within <i>E. lata</i>	65
4.4	Discussion	75
Chapter 5	Detection of <i>E. lata</i> in infected grapevine wood	78
5.1	Introduction	78
5.2	Methods	79
	5.2.1 PCR-based detection of <i>E. lata</i>	79
	5.2.1.1 PCR amplification conditions	79
	5.2.1.2 DNA extraction protocols	80
	5.2.2 Southern hybridisation-based detection of <i>E. lata</i>	84
	5.2.2.1 Slot blot transfer	84
5.3	Results	85
	5.3.1 Rapid extraction protocol of Lecomte et al. (2000)	85
	5.3.2 Rapid extraction protocol of Irelan et al. (1999)	87
	5.3.3 SEAPS extraction protocol	88
	5.3.4 CTAB-based extraction protocol	88
	5.3.5 Qiagen DNeasy kit	89
	5.3.6 Modified DNeasy extraction protocol	89
	5.3.7 Bio-101 soil DNA extraction kit	89
	5.3.8 Silica-based extraction protocol	90
	5.3.9 Southern hybridisation-based detection of <i>E. lata</i>	91
5.4	Discussion	95
Chapter 6	Production of secondary metabolites by <i>E. lata</i> on artificial media	100

6.1	Introduction	100
6.2	Methods	101
6.2.1	Fungal isolates	101
6.2.2	Growth media	101
6.2.3	Isolation of metabolites	102
6.2.3.1	Liquid media	102
6.2.3.2	XAD <sup>®</sup> -amended media	102
6.2.3.3	Agar media	102
6.2.4	HPLC analysis	103
6.2.5	Toxicity of secondary metabolites to grapevine leaf discs	103
6.2.6	Data analysis	104
6.3	Results	104
6.3.1	Production of secondary metabolites on liquid media	104
6.3.1.1	Variation in secondary metabolite production between isolates grown on liquid media	112
6.3.2	Solid media	118
6.3.3	Toxicity of secondary metabolites towards grapevine leaf discs	121
6.3.4	Data analysis	122
6.4	Discussion	123
Chapter 7	Production of secondary metabolites by <i>E. lata</i> on grapevine cane extracts	129
7.1	Introduction	129
7.2	Methods	130
7.2.1	Fungal growth media	130
7.2.2	Isolation of metabolites	130
7.2.2.1	Ground grapevine cane with water	130
7.2.2.2	Liquid grapevine cane extract	131
7.2.2.3	Grapevine cane extract agar	131
7.2.3	Toxicity of secondary metabolites towards grapevine leaf discs	131
7.2.4	Data analysis	131
7.3	Results	131
7.3.1	Ground grapevine cane with water	137
7.3.1.1	Ground grapevine cane (20 days)	137
7.3.1.2	Ground grapevine cane (30 days)	137
7.3.2	Liquid cane extract (30 days)	140
7.3.3	Grapevine extract agar (30 days)	140
7.3.4	Toxicity of secondary metabolites towards grapevine leaf discs	141
7.3.5	Data analysis	144
7.4	Discussion	146
Chapter 8	General Discussion	151
Appendix A	Buffers and Reagents	160
Appendix B	Fungal growth media	164
Appendix C	HPLC Chromatograms following growth of isolates on artificial media	167
Appendix D	HPLC Chromatograms following growth of isolates on artificial media	177
References		181

## Abstract

---

*Eutypa* dieback of grapevines, caused by *Eutypa lata*, is a major cause of reduced longevity in vineyards worldwide. The fungus grows in the woody tissue of infected vines, producing translocatable toxins that cause foliar symptoms of the disease. By the time foliar symptoms are evident the pathogen may have become well established in the vine. One aim of this study was to develop DNA markers to allow rapid reliable identification of *E. lata* and to detect the pathogen in infected wood. The second aim was to analyse secondary metabolite production by *E. lata* in order to gain information on the compounds responsible for the foliar symptoms of the disease and to identify metabolites which could be used as markers to detect the early stages of the disease prior to the expression of foliar symptoms. In addition, genetic variation of the pathogen was assessed using RFLP and RAPD analysis.

Two techniques were used to develop DNA markers; first, SCAR markers derived from RAPD fragments were developed and, second, an *E. lata* genomic DNA library was constructed, from which DNA fragments specific to *E. lata* were identified. These markers were used in either PCR- or Southern hybridisation-based assays to detect the pathogen in infected wood. PCR-based detection of the pathogen in infected wood was prone to inhibition by phenolic compounds, however, Southern hybridisation techniques were capable of detecting *E. lata* in wood. Genetic variation among 38 isolates of *E. lata* was assessed using six randomly selected clones from the genomic DNA library. A subset of 11 isolates was subjected to RAPD analysis using 10 random primers. Considerable genetic diversity, in terms of RFLP and RAPD profiles, was observed among isolates. There was no apparent correlation between grouping of isolates following neighbour joining analysis and either host species or geographic origin of

isolates. The RAPD and RFLP profiles of two isolates differed significantly from the majority of the other isolates. These isolates, which were morphologically similar to all other isolates, were subsequently found not to be *E. lata*.

Secondary metabolite production of 11 isolates was analysed by HPLC following growth on a range of media. A wider range of secondary metabolites was detected in *E. lata* than has previously been reported. Two of the secondary metabolites, eutypine and an unidentified compound with a retention time of 19.6 min, were produced by eight of nine isolates of *E. lata*. Neither of the non-*E. lata* isolates produced these compounds. It was concluded that the remaining isolate of *E. lata* may have lost the ability to produce these compounds following storage. Whilst a wider range of isolates needs to be screened before a candidate marker can be selected, these results suggest that certain compounds are present in the majority of *E. lata* isolates and, hence, may prove suitable markers for the detection of the pathogen prior to the expression of foliar symptoms.

The molecular probes developed in this study will allow the rapid and reliable identification and detection of *E. lata* in grapevine cane or wood. These probes also have the potential to be used as a research tool to gather information on the epidemiology of the disease and to assess the efficacy of potential control agents against *E. lata*. Suitable control measures could then be applied to vines which have been shown by the use of chemical markers to have latent infection. Used in combination, therefore, the DNA and biochemical markers could facilitate improved management of eutypa dieback.

## Declaration

---

This thesis contains no material which has been accepted for the award of any other degree or diploma in any University or other tertiary institution. To the best of my knowledge and belief, this thesis contains no material previously published or written by another person, except where due reference has been made in the text.

I give consent to this thesis being made available for photocopying and loan when deposited in the University Library.

Signed:

Date:

## Acknowledgements

---

First I would like to thank my supervisors, Drs Eileen Scott, Belinda Stummer, Trevor Wicks and Mary Cole. In particular, I thank Eileen and Belinda, both for editing the manuscript and for constant support and enthusiasm over the last 3 ½ years.

This research was supported by the Commonwealth Cooperative Research Centres Program and conducted by the CRC for Viticulture with support from Australia's grapegrowers and winemakers through their investment body the Grape and Wine Research and Development Corporation, with matching funds from the Federal government. Thanks also to the American Vineyard Foundation, the CRCV visiting scholars program and the GWRDC for financial support which allowed me to spend 4 months at the USDA in California as part of my studies. Sincere thanks to Dr Russell Molyneux and Noreen Mahoney for hosting my visit to California and teaching me the techniques required for the analysis of secondary metabolites. In particular, I thank Russell for assistance in editing the appropriate sections of my thesis and Noreen for assistance with HPLC analysis and extractions.

I also thank Drs Nancy Irelan and Richard DeScenzo, E. & J. Gallo Winery, for providing Gallo-proprietary PCR diagnostic primers for the detection of *E. lata* along with a research protocol for using the primers to detect *E. lata* in grape tissue, and for advice regarding the use of these primers. These primers are the subject of pending and allowed patents in various countries, including the United States and Australia.

Thank you to Dr Mette Creaser and Sharmini John for providing grapevine cane samples and fungal isolates, and to Drs Belinda Stummer, Belinda Rawnsley, Peter Long, Rosie Bradshaw and Mary Cole for providing fungal isolates. I also thank Dr Maurice Carter, whose collection of *E. lata* isolates was used extensively in this study. I also thank the staff and students in labs N105 and N107, in particular Belinda Rawnsley, Suzanne Colmagro and Tim Zanker for their friendship and support over the past 3 ½ years. In addition I thank the administrative staff, in particular Gary Taylor and Heather Fraser for assistance throughout the course of my candidature.

Finally, I would like to thank both my parents, without whose efforts this thesis could never have been written.



## Abbreviations

---

°C	degree Celsius
AFLP	amplified fragment length polymorphism
amp	ampicillin
ANGIS	Australian National Genomic Information Service
ATP	adenosine 5'-triphosphate
bp	base pair
CIAP	calf intestinal alkaline phosphatase
CTAB	hexadecyltrimethylammonium bromide
cv	cultivar
dATP	2'-deoxyadenosine 5'-triphosphate
dCTP	2'-deoxycytosine 5'-triphosphate
dd H <sub>2</sub> O	double distilled water
dGTP	2'-deoxyguanosine 5'-triphosphate
DNA	deoxyribonucleic acid
dNTP	2'-deoxynucleotide triphosphatases
dTTP	2'-deoxythymidine 5'-triphosphate
EDTA	ethylenediamine <i>tetra</i> acetic acid
g, mg, µg, ng	gram, milligram, microgram, nanogram
h	hours
HPLC	high performance liquid chromatography
IPTG	isopropyl-β-D-thiogalactoside
ITS	internal transcribed spacer
kb	kilo base
l, ml, µl	litre, millilitre, microlitre
M, mM	molar, millimolar
mAU	milli absorbance units
min	minute
MYB	malt yeast broth
NaCl	sodium chloride
NaOH	sodium hydroxide
PCR	polymerase chain reaction
PDA	potato dextrose agar
PDB	potato dextrose broth
PVP-10	polyvinylpyrrolidone, molecular weight 10,000
RAPD	random amplified polymorphic DNA
rDNA	ribosomal DNA
RFLP	restriction fragment length polymorphism
RNase A	ribonuclease A
RO	reverse osmosis
rpm	revolutions per minute
Rt	retention time
SCAR	sequence characterised amplified region
SDS	sodium dodecyl sulphate
TAE	Tris-acetate-EDTA
TBE	Tris-borate-EDTA
TE	Tris-EDTA
TES	Tris-EDTA-SDS
UV	ultra violet
V	volts
vol	volume(s)
X-Gal	5-bromo-4-chloro-3-indolyl-galactopyranoside

---

# Chapter 1 General Introduction

---

## 1.1 Introduction

Dieback caused by the ascomycete fungus *Eutypa lata* (Pers:Fr) Tul, anamorph *Libertella blepharis* A.L. Smith, is a major disease of grapevines, *Vitis vinifera*, and is the main cause of reduced longevity in vineyards worldwide (Moller & Lehoczky, 1980; Munkvold, Duthie & Marois, 1993). The disease affects mainly vines over 8 years old and causes a gradual decline of health and reduction of yield. Ultimately the disease kills infected cordons or entire vines. *E. lata* affects many elite vineyards in the premium grape growing regions of South Australia, and is regarded as one of the greatest threats to the heritage vineyards of this area (Wicks & Hall, 1997).

Currently, the only method of controlling the disease once it has become established in a vine is by removing all infected wood and reworking the vine. Because there is a 2 to 8 year delay before disease symptoms become apparent, by the time a vine is diagnosed with eutypa dieback the pathogen has extensively colonised the woody tissue, and removal of infected wood and reworking of vines becomes an expensive procedure. Therefore, there is a need to develop an assay which will enable quick and reliable diagnosis of the pathogen. There is also a requirement for tools to enable information to be gathered regarding the rate of spread and location of the pathogen in infected tissue. Such information could be used to enhance management of eutypa dieback, and as a means of assessing potential control agents against the pathogen.

In this chapter, the history and economic impact of eutypa dieback, and the biology of the pathogen will be discussed. Techniques which may be used for the early diagnosis and detection of plant disease will also be reviewed.

## 1.2 History of *Eutypa* as a pathogen

The genus *Eutypa* was established by Tulasne and Tulasne in 1863 (Cannon, 1991). Members of the genus belong to the order Diatrypales, division Ascomycota (Hawksworth *et al.*, 1995). The first record of a member of the genus *Eutypa* as a pathogen dates from 1933 when the deuteromycete *Cytosporina*, initially described in 1900, was shown to cause a dieback disease referred to as 'gummosis' on apricot trees in Australia (Samuel, 1933). Pathogenicity experiments conducted in 1956 showed that *Cytosporina* was, in fact, the anamorph of *Eutypa armeniacae* Hansford & Carter, and

the ascospores of *E. armeniacae* were the source of inoculum (Carter, 1957a). In the 1950s *E. armeniacae* was discovered in New Zealand (Dingley, 1960) and in the 1960s and 1970s the pathogen was found to cause dieback of woody species in many regions throughout the world including Europe, South Africa and North America.

Although initially named *E. armeniacae*, after a comprehensive review of the genus *Eutypa* (Rappaz, 1984), and in recognition of the fact that *E. armeniacae* exists as a pathogen or saprophyte on many plant species, *E. armeniacae* has, since 1985, been considered synonymous with *E. lata*, the type species of the genus. Hence, the causal agent of the dieback disease is hereafter referred to as *E. lata*. The asexual stage of *E. lata* is now referred to as *Libertella blepharis* A.L. Smith, rather than *Cytosporina* sp., in recognition of the fact that *Libertella*, a deuteromycete genus initially described in 1900, is the earliest known name for the anamorph of *E. lata* (Smith, 1900; Cannon, 1991). By 1991 *E. lata* had been isolated from a total of 88 plant species from 24 families. However, it is not known whether the fungus is pathogenic towards all these hosts (Carter, Bolay & Rappaz, 1983; Bolay & Carter, 1985; Carter, 1991). It is believed that grapevine may be a universal host to the pathogen (Carter *et al.*, 1985).

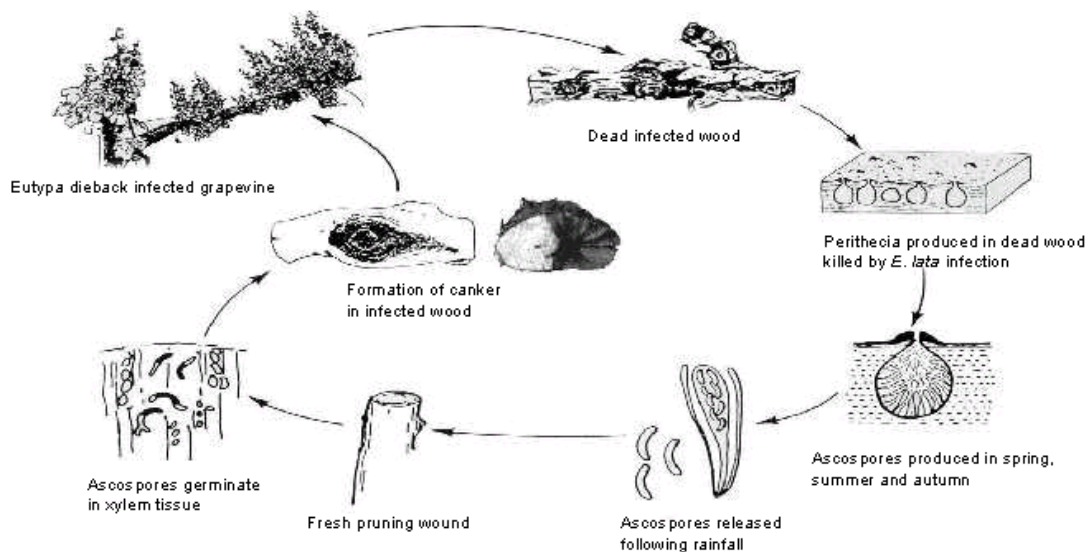
### 1.3 *Eutypa* dieback of grapevines

In grapevines, a disease formerly referred to as 'dead arm' has been recognised for almost 100 years in North America (Reddick, 1909), and in Australia 'dying arm' has been a noted disease of vines for over 60 years. The causal agent of these diseases was initially thought to be *Phomopsis viticola* (Reddick, 1909; Coleman, 1928). It was also suggested that the symptoms could be caused by viral infection of vines, however this theory was disproved in 1967 (Francki & Crowley, 1967). Although perithecia of *E. lata* (syn. *E. armeniacae*) were observed on grapevines in the 1950s (Carter, 1957b), a series of pathogenicity tests initiated at this time did not induce symptoms on inoculated vines following examination 6 months after inoculation (Carter, 1991). However, by the 1970s *E. lata* was consistently being associated with dieback of grapevines throughout the world (Dye & Carter, 1976; Kouyeas *et al.*, 1976; Moller *et al.*, 1977) and, in 1978, a series of pathogenicity tests confirmed that the disease referred to as dead arm of grapevines was caused by *E. lata*, the same species which caused gummosis of apricot trees (Moller & Kasimatis, 1978). The lack of symptoms observed in the initial pathogenicity tests (Carter, 1957b) was due to the fact that an extended incubation period of several years is required before vines exhibit foliar symptoms (Moller *et al.*, 1978; Carter, 1991).

### 1.3.1 Host Pathogen Interactions

#### 1.3.1.1 Disease cycle

*E. lata* is a vascular pathogen which infects grapevines at the site of fresh pruning wounds. The disease cycle is given in Figure 1.1. There is some evidence to suggest that conidia may play a role in initiating infection (Adam, 1938; Belarbi & Mur, 1983; Duthie & Marois, 1991; Ju, Glawe & Rogers, 1991; Hughes, Munkvold & Samita, 1998). However, it is now generally believed that the sole means of infection is by the spread of ascospores (Carter, 1991). This view is supported by vegetative compatibility and DNA analysis of *E. lata* populations, which indicate an extremely high degree of genetic diversity in populations of *E. lata* both within and between vineyards (Cortesi and Milgroom, 2001; DeScenzo et al., 1999; Irelan et al., 1999; Péros and Berger, 1999; Péros et al., 1997; Péros and Larignon, 1998; Péros et al., 1996). The function of conidia remains unknown, although it is believed that they may act as spermatia (Carter, 1991).



**Figure 1.1** Life cycle of *E. lata* in infected grapevine tissue (Pearson and Burr, 1981).

Ascospores are produced in perithecia which are contained within stromata on the outer surface of dead wood. Stromata develop on the outer layers of wood which has been killed by the pathogen. Mature stromata, which are completely exposed on the wood surface, are visible as a dull black layer with a slightly rough surface caused by the protruding necks of perithecia. The perithecia of *E. lata* are flask shaped structures. Each perithecium contains numerous asci, and each ascus contains eight ascospores, of 6-11  $\mu\text{m}$  in length and 1.5-2  $\mu\text{m}$  in width (Carter, 1957a).

Prior to the production of perithecia the anamorph, *L. blepharis*, is visible on the surface of stromata. Anamorphic structures are visible as pycnidia, which contain conidiophores. These conidiophores produce numerous conidia of 18-25  $\mu\text{m}$  in length and approximately 1  $\mu\text{m}$  in width (Carter, 1957a).

Ascospores are dispersed by wind and germinate in the xylem of host plants following deposition on an open wound surface. Wounds are at their most susceptible immediately after pruning although infections may be initiated up to 7 weeks after wounds are inflicted (Petzoldt, Moller & Sall, 1981; Munkvold & Marois, 1995; Chapuis, Richard & Dubos, 1998). Although it is generally believed that *E. lata* only infects wounds in mature wood, recent research (Creaser & Wicks, 2002) suggests that the pathogen is also capable of infecting young canes. However, it is likely that these infections would be removed following pruning in subsequent years. Therefore, routine annual pruning wounds are not believed to be a major source of entry for the pathogen. The main source of entry into grapevines is via large pruning wounds associated with the re-working of vines. Vines which are less than 5 years old do not generally become infected, and the appearance of symptoms is rare before vines have reached 8 to 10 years of age (Moller et al., 1974; Duthie et al., 1991a; Pascoe, 1999).

Perithecium formation occurs only in areas with an annual rainfall greater than 350 mm (Carter, 1957a; Ramos, Moller & English, 1975). Sprinkler irrigation may also provide an adequate source of moisture to allow the formation of perithecia in areas with a low rainfall (Munkvold & Marois, 1991; Munkvold & Marois, 1994). It is generally believed that perithecia are produced in dead wood 3-5 years after the death of the host (Carter, 1960; Bolay *et al.*, 1985). However, more recent research (Cortesi & Milgroom, 2001) suggests that perithecia may also be present on living vines infected with the pathogen. A period of at least 5 years is required from the initiation of infection to the production of perithecia (Munkvold *et al.*, 1993).

Ascospores are released from perithecia following a minimum of 2 mm of rainfall, for a period of up to 36 hours (Carter, 1957a; Chapuis *et al.*, 1998). Following the release of ascospores there is a period of approximately 12 days during which fresh ascospores mature, and are subsequently released following the next rainfall (Carter, 1991). In Australia ascospores are released abundantly between September and May, however, few are released between June and August (Carter, 1957a; Moller & Carter, 1965). Long distance wind dispersal of ascospores is believed to play an important role in the

disease cycle. In regions where climatic conditions are not conducive for the production of perithecia there are reports of ascospores being carried over 100 km to initiate infection in these areas (Ramos *et al.*, 1975; Petzoldt, Sall & Moller, 1983).

### 1.3.2 Symptoms of eutypa dieback

#### 1.3.2.1 Woody tissue symptoms

Following germination of ascospores in the xylem, mycelium spreads to the cambium and phloem tissue and ultimately to the bark of plants. Once a vine has become infected there is a latent period of between 3 and 8 years during which time the mycelium colonises the vascular tissue but no foliar symptoms are visible (Moller *et al.*, 1978; Munkvold *et al.*, 1994; Chapuis *et al.*, 1998). The earliest symptoms are generally the formation of cankers around pruning wounds in older wood (English & Davis, 1965) and the necrosis of vascular tissue, which impedes water and nutrient movement within the plant (Moller *et al.*, 1980). Cankers are difficult to detect because they are covered with bark. However, removal of bark around the canker reveals a characteristic region of darkened or discoloured wood. If a cross-section is made of an infected trunk the canker appears as a wedge-shaped area of discoloured wood spreading to the centre of the trunk (Figure 1.2). Ultimately this canker is capable of killing the infected cordon. If the disease is allowed to progress unchecked the entire vine may be killed within 10 years of initial infection (Pascoe, 1999).

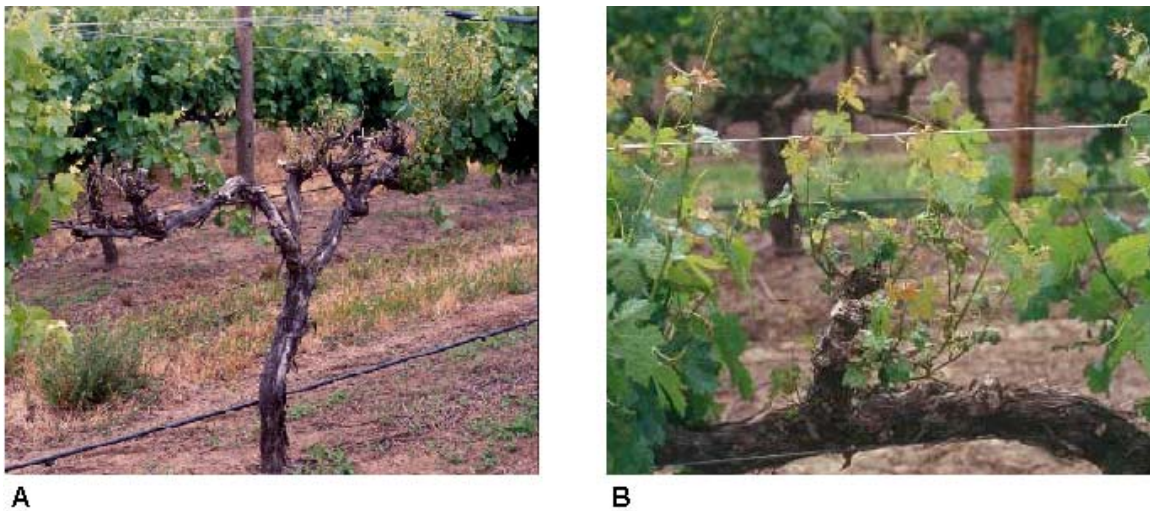


Figure 1.2 Cross section of a grapevine trunk infected with *E. lata*, showing the characteristic wedge-shaped region of stained, necrotic tissue.

#### 1.3.2.2 Foliar symptoms

Mycelium of *E. lata* has never been isolated from the foliage of grapevines. It is believed that foliar symptoms are caused by the action of translocatable toxins which

are produced by the fungus in the vascular tissue and subsequently transported to the foliage (Moller & Kasimatis, 1981). Characteristic foliar symptoms of eutypa dieback include the dwarfing of internodes and tattering and necrosis of leaves as well as the death of infected cordons (Figure 1.3). The pathogen may also cause the failure of berry set, uneven rates of berry maturation and shrivelling of bunches following flowering. This can lead to the failure of bunches to mature, or premature dropping of berries from the vine (Moller *et al.*, 1978; Carter, 1991; Wicks & Davies, 1999). Foliar symptoms are initially confined to one arm of infected vines, however, as the disease progresses symptoms may spread throughout the entire vine.



**Figure 1.3**     **A**     Dead cordon (left) and stunting of internodes (right) of a grapevine with *E. lata*.  
                   **B**     Close up view of leaf tattering and necrosis associated with infection of the vine by *E. lata*.

### 1.3.3 Relative susceptibility of *V. vinifera* cultivars to *E. lata*

All varieties of grapevine are believed to be susceptible to invasion by *E. lata* and to the gradual destruction of vascular tissue caused by hydrolytic enzymes produced by the fungus (Schmidt, Wolf & Lorenz, 1999). However, there are differences in the severity of foliar symptoms between different cultivars. Cultivars which exhibit pronounced foliar symptoms include Grenache, Cabernet Sauvignon, Shiraz, Sauvignon Blanc, Gewürztraminer and Chenin Blanc. Conversely, Chardonnay, Merlot, Pinot Noir and Semillon show much less pronounced foliar symptoms (Mauro *et al.*, 1988; Tey Rulh *et al.*, 1991; Munkvold *et al.*, 1995; Anon, 1997). Recent research suggests that degrees of resistance exhibited by some varieties could be due to the detoxification of the fungal secondary metabolite eutypine (see section 1.6) by enzymatic conversion to a substance

named eutypinol, which is not toxic to grapevines (Colrat *et al.*, 1999a; Colrat *et al.*, 1999b). *In vitro* selection of eutypine-resistant varieties has been achieved and the possibility of creating eutypine resistant grape clones is being examined (Soulie, Roustan & Falot, 1993; Colrat *et al.*, 1999a). However, even if eutypine-resistant vines were successfully generated vines would still be susceptible to invasion by *E. lata* and the subsequent necrosis of vascular tissue.

## 1.4 Control of eutypa dieback

There are currently no chemicals registered for the control of *E. lata* in Australia, and no chemicals are known to cure eutypa dieback. At present the most successful method of controlling the disease is by preventing infection. Methods by which this may be achieved include the removal of infected wood from vineyards, thereby minimising possible infection sources (Carter, 1991), delaying pruning until late in the dormant season (Petzoldt *et al.*, 1981), avoiding pruning immediately following rainfall and applying fungicides to wound surfaces immediately after pruning (Anon, 1997).

Research has been carried out in Australia (Moller & Carter, 1969; Carter & Price, 1974; Carter & Price, 1975; Creaser *et al.*, 2002; John *et al.*, 2003) and elsewhere (Ferreira *et al.*, 1991; Munkvold and Marois, 1993a, 1993b; Irelan *et al.*, 1999; McMahan *et al.*, 2001; Schmidt *et al.*, 2001a; Schmidt *et al.*, 2001b; Amborabé *et al.*, 2002) into the efficacy of both biological and chemical control measures. Some control agents, particularly the fungicide, benomyl, are capable of preventing infection. However, this compound is not registered for the control of *E. lata* in Australia and has recently been withdrawn from the market. Growers are advised to avoid making large cuts in wet weather when ascospores are released from mature perithecia. Because no curative control agents are known, once vines have contracted the disease removal of the infected cordon or trunk parts, followed by reconstruction of the vine is the only method by which eutypa dieback may be controlled. The current recommendation given to grape growers in Australia is to remove all obviously infected wood from the vine as well as a 10-20 cm portion of apparently healthy wood (Anon, 1997). However, it is not known whether this is sufficient to remove all mycelium of *E. lata* from infected vines.



## 1.5 Significance of the pathogen to the grape growing industry

As mentioned previously, eutypa dieback greatly reduces yield and ultimately kills infected vines. Surveys conducted in South Australia suggest that approximately 5% of all vines are infected with *E. lata* (Highet & Wicks, 1998), with certain premium varieties, such as Grenache and Shiraz, having an overall infection level of 9.3 and 8.1%, respectively (Highet *et al.*, 1998). In heavily infected vineyards this figure may rise to 60% (Wicks *et al.*, 1997). It seems likely that the estimate of 5% overall infection is a conservative one. There are several reasons for this; first, the surveys by Highet and Wicks were carried out in December, when mild symptoms may have been concealed by healthy growth from other parts of the vine. Second, dead or dying vines were not included in the survey as it was not possible to ascertain reliably whether these vines had been killed by *E. lata*; and third, because of the 2-8 year delay prior to the expression of foliar symptoms it is possible that many more vines were infected by the pathogen but were not yet displaying symptoms. In California and in the Bordeaux region of France up to 90% infection of vines in individual vineyards has been observed (Duthie *et al.*, 1991; Tey Rulh *et al.*, 1991; Munkvold *et al.*, 1993).

The majority of work relating to yield loss caused by *E. lata* has been conducted in California. These studies indicate that infection by *E. lata* leads to yield reductions of between 30 and 62% (Munkvold, Duthie & Marois, 1992; Munkvold *et al.*, 1994). A recent study carried out in five vineyards in the Eden Valley of South Australia indicated that infection of the cultivar Shiraz reduced bunch numbers on heavily infected vines by approximately two thirds (Wicks *et al.*, 1999). In heavily infected vineyards, this would equate to a yield loss of 1500 kg/ha, with an estimated cost to growers of A\$ 2800/ha (Wicks *et al.*, 1999). However, it is important to note that this figure does not take into account costs associated with re-working or removal of infected vines, nor does it allow for the fact that wine produced from infected vines may be of lower quality than wine produced from healthy vines. Although the cost of eutypa dieback to the entire Australian grape and wine industry remains unknown it has been estimated that the disease resulted in yield losses of A\$ 20 million in Shiraz alone in 2000/2001 (Mette Creaser, *pers. com.*, August 2001).

Research conducted in California clearly demonstrates the significance of the disease to the grape growing industry. In the primary grape growing regions of California control of *E. lata* was the most expensive disease management practice in vineyards between

1997 and 1999, with management costs being 72% higher than those of the next most expensive disease, powdery mildew (Irelan, Gubler & DeScenzo, 1999). In the same region disease remediation has been estimated to cost between US\$ 250 - US\$ 500 per acre, however, this figure does not include losses in revenue due to yield reductions caused by *E. lata* (Irelan *et al.*, 1999). It has been estimated that the disease costs the entire Californian grape and wine industry in excess of US\$ 260 million per annum (Siebert, 2000).

In Australia, the disease is prevalent in the south-east, namely the Clare Valley, Barossa Valley, Southern Vales, Coonawarra and Padthaway regions of South Australia as well as north eastern Victoria (Anon, 1997). However, it is also a risk in drier regions such as the Riverland, especially in re-worked vineyards with overhead irrigation (Magarey & Carter, 1986). The disease has also been recorded in vineyards in New South Wales and Western Australia.

## 1.6 Production of secondary metabolites by *E. lata*

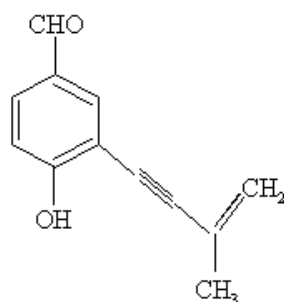
*E. lata* produces a variety of extracellular compounds including acetylenic phenol secondary metabolites (Renaud *et al.*, 1989a; Renaud, Tsoupras & Tabacchi, 1989b; Molyneux *et al.*, 2002), sterols (Chapuis, Corio-Costet & Malosse, 1996) and hydrolytic enzymes (Schmidt *et al.*, 1999). The foliar symptoms of eutypa dieback are believed to be caused either by eutypine or related acetylenic phenol compounds. The toxicity of culture filtrates of *E. lata* towards plant material was initially demonstrated by Tsoupras *et al.* (1988) and Mauro *et al.* (1988). Tsoupras and co-workers (1998) isolated six major acetylenic phenol compounds from a single isolate of *E. lata* and demonstrated that the culture filtrates of this isolate were toxic towards tomato leaves and Cabernet Sauvignon protoplasts. Of these six compounds, the most phytotoxic was eutypine (Tey Rulh *et al.*, 1991). Mauro *et al.* (1988) exposed *in vitro* grapevine plantlets and excised plantlet leaves to the entire culture filtrates of four *E. lata* isolates and demonstrated that these filtrates were phytotoxic towards the plant tissue. Furthermore, inoculation of *in vitro* plantlets with the same isolates from which culture filtrates were obtained showed a correlation between isolate virulence and filtrate toxicity (Mauro *et al.*, 1988).

Eutypine, 4-hydroxy-3-(3-methyl-3-butene-1-ynyl) benzaldehyde, is a 1,2,4 tri-substituted benzene with the formula C<sub>12</sub>H<sub>10</sub>O<sub>2</sub> (Figure 1.4), which exhibits marked phytotoxicity towards *in vitro* grapevine plants, excised grapevine leaves (Tey Rulh *et al.*, 1991) and grapevine cell suspension cultures (Deswarte *et al.*, 1996a). The presence

of eutypine in the sap and inflorescence of diseased plants has been confirmed by spectroscopic analysis of vineyard specimens (Tey Rulh *et al.*, 1991; Tabacchi, 1994).

Although a range of secondary metabolites has been isolated from liquid cultures of *E. lata* (Tsoupras *et al.*, 1988; Renaud *et al.*, 1989a; Renaud *et al.*, 1989b; Tey Rulh *et al.*, 1991; Molyneux *et al.*, 2002), foliar symptoms of Eutypa dieback have largely been attributed to eutypine (Tey Rulh *et al.*, 1991). Hence, subsequent research has focussed largely on the characteristics of this compound.

Eutypine is believed to accumulate in the cytoplasm of grapevine cells (Deswarte *et al.*, 1996a). Whilst the mode of action of the toxin has not been fully elucidated, research to date suggests that the toxin inhibits plant growth by uncoupling phosphorylative oxidation, thereby inhibiting mitochondrial function, as well as by disrupting intracellular membranes and causing cytoplasm lysis and vesiculation, hence disrupting chloroplast function (Deswarte *et al.*, 1994; Deswarte *et al.*, 1996b). More recent research has demonstrated that the tolerance of some cultivars of grapevine to the toxin may be due to their ability to detoxify eutypine to eutypinol, a metabolite believed not to be toxic towards grapevine (Guillen *et al.*, 1998; Colrat *et al.*, 1999a; Colrat *et al.*, 1999b). Isolation of a eutypine-reducing enzyme from mung bean (*Vigna radiata*) which converts the toxin to eutypinol (Guillen *et al.*, 1998), and the subsequent expression of the enzyme in grapevine cells (Roustan *et al.*, 2000) led to the production of grapevine callus tissue which was resistant to eutypine.



**Figure 1.4** Structure of eutypine, C<sub>10</sub>H<sub>12</sub>O<sub>2</sub> (Mauro *et al.*, 1988)

However, it now seems likely that *E. lata* produces a range of potentially toxic secondary metabolites and that eutypine may not be solely responsible for the foliar symptoms of eutypa dieback.

Initial research into the production of acetylenic phenols by *E. lata* (Renaud *et al.*, 1989a; Renaud *et al.*, 1989b) was conducted following growth of one isolate on a single defined medium (Pezet, 1983). Although a variety of compounds was identified, the predominant compound was eutypine and subsequent research focused largely on this compound. However, previous research on various fungi including *Cochliobolus* (Ghisalberti & Rowland, 1993), *Aspergillus* (Rahbaek, Frisvad & Christophersen, 2000), *Fusarium* (Luz, Paterson & Brayford, 1990; Herrmann, Zocher & Haese, 1996; Yoshitsugu *et al.*, 1999) and *Ascochyta* (Evidente *et al.*, 1993) indicates that the type and amount of metabolites produced in culture is to a large extent dependent upon the composition of the culture medium. Additional factors such as temperature, carbon source, nitrogen source and growth phase have also been linked to variation in toxin production in *Alternaria tenuissima* (Young, Davis & Diener, 1980), *Pyricularia oryzae* (Lebrun *et al.*, 1990) and *Penicillium* spp. (Frisvad & Filtenborg, 1983).

Analysis of sterol production showed an increase in the amount of sterols produced when *E. lata* was grown on solid malt extract agar rather than inorganic liquid medium, however, the same types of sterol were produced on both media (Chapuis *et al.*, 1996). When analysing production of extracellular hydrolytic enzymes by *E. lata*, differences in production were dependent upon the type of liquid medium used and, following growth on grapevine wood, on the age of autoclaved wood upon which the fungus was grown (Schmidt *et al.*, 1999).

Recent research suggests that eutypine may not be produced by all isolates of *E. lata*, implying that some other compounds are at least partially responsible for the symptoms of eutypa dieback (Molyneux *et al.*, 2002). Analysis of three isolates of *E. lata* grown on potato dextrose broth and malt extract/yeast extract broth showed that only one isolate produced eutypine in liquid culture (Molyneux *et al.*, 2002). One isolate did not produce any metabolites in significant quantities. The remaining isolate, known to be pathogenic towards grapevine, did not produce eutypine. However, it did produce related acetylenic phenol compounds including eutypinol, the putative detoxification product of eutypine *in planta*. Also present were sicayne, previously isolated from *Helminthosporium siccans*, and two novel metabolites named eulatinol and eulatachromene. Considerable differences in acetylenic phenol secondary metabolite composition were noted following growth of *E. lata* on PDB and MYB. Isolates grown on MYB produced a wider range of metabolites, however, some metabolites were

produced in larger quantities following growth on PDB (Molyneux *et al.*, 2002). Given the differences in secondary metabolite production between media, and the fact that Molyneux *et al.* (2002) analysed only three isolates of the pathogen, more isolates need to be analysed in order to gain an increased understanding of the variety of secondary metabolites produced by *E. lata*.

## 1.7 Diagnosis of eutypa dieback

As noted previously, symptoms of eutypa dieback do not become evident until vines have been infected for several years. In addition some vines may exhibit foliar symptoms one season but not the next (Creaser & Wicks, 2001), and symptoms which are readily apparent at the start of a growing season often become obscured by healthy growth from uninfected parts of the vine later in the year. There is also a variety of other pathogens or pests which may cause similar symptoms. For example, *Phomopsis* spp. or bud mites may cause similar foliar symptoms and a range of other fungal vascular pathogens, for example *Phaeoconiella chlamydosporum*, *Phaeoacremonium aleophilum*, *Phellinus* and *Botryosphaeria* spp. also cause staining and necrosis of the vascular tissue of grapevines.

At present the only reliable method of determining whether a vine is infected with *E. lata* is by culturing wood-chips taken from tissue at the suspected site of infection. This is a time consuming process, requiring a minimum of 25 wood-chips to be sampled from each infection site (Petzoldt *et al.*, 1981), and is of limited use to growers as it requires destructive sampling of vines. In addition, because perithecia of *E. lata* are not produced in dry areas or in artificial culture, identification of the pathogen must be carried out solely on the basis of anamorph morphology. Because the hyphae of *E. lata* have no unique diagnostic features, it is necessary to observe the formation of conidia in culture to confirm the identity of the pathogen. However, production of these structures may take up to 2 months and some isolates do not produce conidia in culture (Carter, 1991). Under these circumstances it may be difficult, or impossible, to distinguish *E. lata* from other ascomycetes (Glawe, Skotland & Moller, 1982).

There is, therefore, a requirement for a rapid, reliable, non-destructive sampling technique which would enable growers to determine whether vines are infected with *E. lata*. A procedure for the early diagnosis of *E. lata* in grapevines would allow remedial measures to limit the spread of disease and, hence, reduce yield loss, to be implemented before the disease becomes widespread throughout the plant. The development of early

detection techniques would also provide tools which could be used to assess new chemical or biocontrol agents for efficacy against *E. lata*, and would enable information to be gathered regarding the biology of the pathogen.

## 1.8 Early diagnosis of fungal plant pathogens

The early diagnosis of plant disease is an important aspect in the management of any horticultural system. Relying upon the appearance of symptoms is often not an appropriate method of disease diagnosis because, by the time symptoms become evident, the disease may have progressed too far for any control measures to be effective. This is particularly relevant in the case of eutypa dieback, where expression of symptoms is delayed for several years following infection. The main requirements of any early diagnostic procedure are that the process should be non-destructive, reliable, sensitive, relatively inexpensive, and should provide a rapid means of determining the presence or absence of the suspected pathogen.

Over recent years a wide variety of techniques has been utilised to develop methods by which plant pathogenic fungi may be detected. These techniques include immunology-based detection systems (Dewey & Priestley, 1994; van de Koppel & Schots, 1994; Dewey & Thornton, 1995), isozyme analysis (Kerssies *et al.*, 1994), and nucleic acid-based methods (Schesser *et al.*, 1991; Paran and Michelmore, 1993; Annamalai *et al.*, 1995; Li *et al.*, 1999; Förster and Adaskaveg, 2000). Another approach which has not been widely used for the diagnosis of plant disease, but which has been used to locate specific compounds within plant tissue, is the use of spectroscopy (Skerritt & Appels, 1995).

### 1.8.1 Immunological techniques

Immunological techniques have been used to detect the presence of plant pathogens since the late 1970s (Schaad, 1979). The most common immunological technique used for the detection of fungal plant pathogens has been the ELISA (enzyme linked immunoabsorbent assay). In this process, untagged antibody is bound to a solid phase, for example to a microtitre plate, and the test sample (*i.e.* the antigen), enzyme-labelled antibody and finally the enzyme substrate are added sequentially, with washing between each step to remove any unbound material. The binding of the antigen (derived from the pathogen) to a specific antibody is visualised by the use of the 'tag' enzyme which reacts with its substrate and generates a coloured product (Miller & Martin, 1988). Immunoassays have been used for the detection of many fungal pathogens including

*Botrytis cinerea* (Bossi *et al.*, 1994; Salinas, Schober & Schotts, 1994), *Verticillium* sp. (van de Koppel *et al.*, 1994) and *Rhizoctonia solani* (Thornton, Dewey & Gilligan, 1994), as well as to detect mycotoxins and other bioactive compounds produced by fungi (Morgan, 1995).

Antibodies specific to *E. lata* hyphae and ascospores have been used to stain *E. lata* selectively in infected wood (Francki & Carter, 1970; Gendloff, Ramsdell & Burton, 1983). This technique has advantages in that it enables the detection of pathogens in complex mixtures of both host and pathogen origin, and can be used as a rapid diagnostic in the field. However, drawbacks of the technique are that it is relatively expensive to generate antibodies specific to plant pathogens, antibodies may be developmentally regulated or show tissue specificity, and developing antibodies with a high degree of specificity may be difficult to achieve (Miller *et al.*, 1988).

### **1.8.2 Isozyme analysis**

Isozymes are different molecular forms of specific enzymes which catalyse the same reaction. Different isozymes carry distinct static charges or have altered molecular weights and hence exhibit varying electrophoretic mobility. This allows differences between isozymes to be detected by starch or polyacrylamide gel electrophoresis. In this process, proteins in crude extracts are electrophoretically separated, and the gel is then stained with an enzyme-specific staining solution to visualise the zones containing specific enzymic activity. Although this technique has been used to analyse variation within fungal species (Boshoff *et al.*, 1996; Graham *et al.*, 1998; Nyasse *et al.*, 1999) as well as to detect fungal pathogens, for example *Fusarium* spp. (Kerssies *et al.*, 1994), isozymes have not been widely used as a fungal diagnostic. This is because isozymes may be developmentally regulated or tissue specific, results may be complex and difficult to interpret, and there may be insufficient isozyme variation to allow for detection of intraspecific variation (Michelmore & Hulbert, 1987).

### **1.8.3 Nucleic acid-based diagnosis**

Since the advent of both restriction fragment length polymorphism (RFLP) analysis and, especially, the polymerase chain reaction (PCR), nucleic acid-based techniques have become one of the most common approaches by which early detection of plant pathogens is routinely accomplished. These techniques have several advantages over immunological and isozyme analysis. Whereas the presence of antigens and isozymes may be developmentally regulated and can also be tissue specific, DNA-based markers

are present at all stages of development of an organism. Further advantages of DNA-based markers, and PCR in particular, are that numerous markers may be rapidly generated, PCR is extremely sensitive, allowing for the theoretical detection of a single molecule of target DNA and, depending on the method by which DNA markers are generated, a broad range of specificity, ranging from the genus to sub-specific level may be achieved. Generation of DNA markers is also relatively inexpensive, and hundreds of PCR primers may be developed at costs comparable to those of developing only a few monoclonal antibodies (Henson & French, 1993).

In order to develop a DNA marker capable of identifying a pathogen in host tissue, it is first necessary to find a fragment of DNA specific to this pathogen, and then to develop methods by which this molecule may be detected in a complex mixture of both host and pathogen origin. There are many techniques available which are capable of detecting DNA sequence variation both within and between fungal populations. These techniques fall into two main categories, these being RFLP- and PCR- based methods.

#### **1.8.3.1 RFLP-based techniques**

RFLPs are generated by the use of restriction enzymes which cut DNA at specific sites. Restriction enzymes recognise specific sequences of DNA between four and eight base pairs long. An alteration of a single base pair at a restriction site will result in failure to cut the DNA strands at the altered site, resulting in the production of a longer DNA fragment (Michelmore *et al.*, 1987). In addition, differences in DNA sequence due to additions, deletions, chromosomal inversions or translocations alter the fragment size of digested DNA.

The fragments generated following digestion of genomic DNA by restriction enzymes can be visualised by the use of agarose gel electrophoresis. However, the complexity of DNA from even simple genomes results in the production of a very large number of DNA fragments, all of different sizes, which are visible as a smear when stained with ethidium bromide on an agarose gel. By radiolabelling a single stranded DNA sequence of interest, and using this labelled 'probe' to search for complementary DNA sequences among the digested DNA, specific DNA sequences within such a digest may be detected. Because of the fragile nature of agarose gels, this cannot be carried out directly, but instead DNA fragments are denatured and the resulting single stranded DNA is transferred from the agarose gel to a nylon or nitro-cellulose membrane. This transfer of fragments is known as Southern blotting (Southern, 1975). Following the



transfer of DNA, the nitrocellulose membrane is incubated along with the radioactive probe. The membrane is then washed to remove any unbound probe, and any probe which has bound to complementary strands of DNA is detected by auto-radiography. This process will allow for the selection of varying numbers of fragments, depending upon the type of probe used.

Conversely, fragments from a restriction digest may be cloned and sequenced and, following either radioactive or enzymic labelling (Walker & Dougan, 1989), these cloned sequences may be used as probes to search genomic DNA of relevant species for sequence homology (Miller *et al.*, 1988).

RFLPs have been widely used to assess variation both within and between populations of plant pathogenic fungi (Christiansen and Giese, 1990; Zézé *et al.*, 1996; Witthuhn *et al.*, 1999; Stummer *et al.*, 2000), and have also been used to develop probes specific to certain fungal species (Koopmann *et al.*, 1994; Buhariwalla *et al.*, 1995; Zézé *et al.*, 1996; Herdina *et al.*, 1997; Melanson *et al.*, 2002).

### **1.8.3.2 PCR-based generation of markers**

Since the development of the PCR technique in the 1980s (Saiki *et al.*, 1985; Saiki *et al.*, 1988), numerous techniques based on this process have been developed which allow rapid, accurate detection of plant pathogens. PCR is a procedure which allows the amplification of very small quantities of specific DNA sequence without prior cloning of the DNA. In this process, DNA is synthesised using two oligonucleotide primers which anneal to opposite strands of the DNA template. A series of repetitive cycles, involving denaturing of the DNA template, annealing of the primer to the template, and the extension of the primers by the activity of DNA polymerase results in an exponential increase of the DNA region of interest (Edel, 1998). This method is simple, and allows for the screening of a large number of individuals using a minimal amount of DNA.

There are a variety of methods by which PCR-based markers may be generated; these include RAPD (random amplified polymorphic DNA), AFLP (amplified fragment length polymorphism), and STS (sequence tagged site)-based markers.

#### **Generation of RAPD-based DNA markers**

The RAPD technique was initially described in 1990 (Welsh & McClelland, 1990; Williams *et al.*, 1990). Single arbitrary primers, usually ten nucleotides in length, are

used to amplify random sequences of DNA from the host genome. Low annealing temperatures (34-37°C) allow binding of the primer to arbitrary regions of the genome which may not be fully complementary to the primer. If the primer anneals to target DNA, providing that the 3' strands of the annealed primers are facing each other, and primer binding sites are within approximately 3 kb of each other, the DNA fragment between primers is amplified.

RAPD amplification detects polymorphisms between isolates which may arise from any of the following events: 1) insertion of a large fragment of DNA between two primer binding sites which increases the size of the original DNA fragment beyond an amplifiable size; 2) deletion of a primer binding site; 3) nucleotide substitution in a primer binding site; or 4) insertion or deletion of a small fragment of DNA between two primer binding sites which alters the size of the amplified fragment (Williams *et al.*, 1990). The major advantages of this technique are that no prior sequence information is required, universal sets of primers may be used and rapidly screened and only small quantities of template DNA are required (Annamalai *et al.*, 1995). The major drawback of the technique is that slight variations within reaction mixtures or amplification conditions have a pronounced effect on the reproducible amplification of RAPD fragments (Muralidharan & Wakeland, 1993; Penner *et al.*, 1993), which may make results difficult to replicate either within or between laboratories.

RAPDs have been widely used to analyse diverse aspects of fungal biology, including differentiating between fungal races (Crowhurst *et al.*, 1991; Pipe, Buck & Brasier, 1995), tracking fungal strains in field experiments (Fegan *et al.*, 1993; Ouellet & Seifert, 1993), analysis of fungal and plant genes involved in plant disease resistance (Adam-Blonden *et al.*, 1994; Benet *et al.*, 1995), and for the examination of taxonomic relationships within and between fungal genera (Braithwaite *et al.*, 1994; Leal *et al.*, 1994; Cooke *et al.*, 1996).

### **Generation of AFLP-based DNA markers**

The AFLP technique was initially described in 1995 (Vos *et al.*, 1995). To generate AFLPs, genomic DNA is cut by two restriction enzymes, one a frequent cutter and the other a rare cutter. In a typical fungal genome of approximately 40,000 kb, this results in the generation of approximately 150,000 DNA fragments (Majer *et al.*, 1996). To reduce the number of fragments generated to a manageable size, double stranded adaptors are ligated to the restriction sites. These adaptors have arbitrary 1, 2 or 3 base

extensions at their 3' end and this typically restricts the number of fragments to between 50 and 70 (Majer *et al.*, 1996). The number of fragments generated may be altered by increasing or decreasing the length of the 3' extension. Whilst this procedure is somewhat more laborious than generation of RAPD fragments, the AFLP technique is a lot less sensitive to minor variation in reaction conditions, allowing for much more reliable replication of results both within and between laboratories than do RAPDs. Since the development of the technique, AFLPs have been widely used in fungal biology both to analyse variation and to develop markers for a range of fungal species (Rosendahl & Taylor, 1997; Gonzalez *et al.*, 1998; Schnieder *et al.*, 1998; Wetzel, Skinner & Tisserat, 1999).

### **Generation of STS-based markers**

An STS is a unique DNA sequence from a known location in the genome which may be amplified using PCR. Sequence tagged sites are generally 200 - 500 bp in length, and primers specific to these sites may be used to detect the presence or absence of this site in samples. Variations within STSs, such as those caused by the insertion or deletion of DNA, may also be detected. A drawback of this method is that development of STS markers requires prior sequence information obtained from cloned DNA. However, STSs have now been extensively used in analysis of fungal genetics, and there is now a wide range of universal primers available which are known to amplify these sites in a broad range of species. Sequence tagged sites which have been used as molecular markers in fungi include those specific to the internal transcribed spacer region (ITS) of rDNA (Schilling, Möller & Geiger, 1996; DeScenzo *et al.*, 1999; Salazar, Jullian & Rubio, 2000), the intergenic spacer region (IGS) of rDNA (Patrik, 2000), repetitive extragenic palindromic (REP) DNA (Buhariwalla *et al.*, 1995); microsatellite repeat sequences, and markers specific to certain genes, for example the  $\beta$ -tubulin or actin genes (Hirsch *et al.*, 2000; Weiland & Sundsbak, 2000).

#### **1.8.3.3 Generation of species-specific primers for diagnostic purposes**

Both the RFLP- and PCR-based techniques outlined above are capable of generating many molecular markers which may be specific to the fungal taxon of interest. Banding patterns generated by these methods may be complex and require extensive analysis. Markers generated from arbitrary DNA sequences such as AFLPs, and especially RAPDs, where a low annealing temperature is used to allow for amplification of sites which may not have 100% homology to the RAPD primer, are not ideal diagnostic

tools. This is because as well as amplifying fungal DNA, they may also amplify DNA from the host plant from which a sample is taken. However, by determining the sequence of a specific DNA fragment that has been produced by one of the above techniques, a reliable molecular marker which will detect the presence or absence of the fungal species of interest by the amplification of a single DNA fragment may be developed.

### **Development of species-specific markers from RFLPs**

Following the digestion of genomic DNA by a restriction enzyme, sequences believed to be specific to the species of interest may be detected by labelling random clones of genomic DNA, and hybridising these probes with the total DNA of the species in question and also with other closely related species which could be expected to share DNA sequence homology with the species of interest. The intensity of the signal, along with the specificity of the probe will allow for the selection of DNA sequences specific to the species of interest. Clones which give a strong signal are likely to represent areas of the genome which contain high copy numbers of the DNA sequence and will provide a more reliable marker for the species (Walker *et al.*, 1989).

Selected clones may be sequenced, and PCR primers which will amplify only this region of DNA may be developed. This technique has been employed to develop species-specific primers allowing for the rapid detection of a range of fungal genera including *Scutellospora* (Zézé *et al.*, 1996; Zézé *et al.*, 1999), *Plasmodiophora* (Buhariwalla *et al.*, 1995) and *Fusarium* (Koopmann, Karlovsky & Wolf, 1994).

### **Development of specific markers from PCR-based markers**

Although STS markers are capable of generating fingerprint patterns specific to certain species or taxa (Matthew, Herdina & Whisson, 1995; Balali *et al.*, 1996), other markers may not possess such a high degree of specificity. When fragments of DNA are relatively large, the sequence of the fragment may be elucidated, and a primer specific to this region developed. A primer which is developed in this fashion is known as a SCAR (Sequence Characterised Amplified Region). The SCAR technique is becoming popular for diagnosing the presence of plant pathogens (Paran and Michelmore, 1993; McDermott *et al.*, 1994; Leclerc Potvin *et al.*, 1999) and has now been used for this purpose in a range of fungi including *Rhizoctonia* (Leclerc Potvin *et al.*, 1999), *Verticillium* (Li *et al.*, 1999) and *Erysiphe* (McDermott *et al.*, 1994), as well as the fungal endophyte *Acremonium implicatum* (Kelemu *et al.*, 2003). SCARs provide an excellent diagnostic tool because, due to their high degree of specificity, they can be

used to amplify specific DNA of the pathogen of interest in a complex mixture of both plant and fungal origin.

#### 1.8.4 Molecular analysis of *E. lata*

Several recent studies have assessed genetic variability within populations of *E. lata* using a variety of the techniques outlined above. The RAPD technique has been utilised to assess variation both within and between populations of *E. lata* (Péros et al., 1996; Péros et al., 1997; Péros and Larignon, 1998; Péros and Berger, 1999; Péros et al., 1999). Analysis of RAPD products demonstrated that there is an extremely high degree of genetic diversity both within and between populations of the pathogen, as would be expected in a population which is predominantly dispersed by ascospores.

In addition to RAPD analysis, Péros *et al.* (1996) analysed isozyme variation within *E. lata* isolates taken from different geographical locations. Whilst polymorphic isozyme markers were detected, more variation was detected using RAPD markers, and it was concluded that RAPDs would prove better suited to analysis of *E. lata* populations than isozymes.

Genetic variation within populations of *E. lata* has also been assessed by AFLP and rDNA ITS region analysis (DeScenzo *et al.*, 1999). AFLP analysis indicated a similar degree of genetic variation within populations of the pathogen to that shown by RAPD analysis. The AFLP data also suggested that there are two distinct populations of *E. lata* in California, both of which are capable of infecting grapevines. As would be expected, analysis of the ITS regions showed less variation between isolates than either RAPDs or AFLPs. Analysis of ITS sequence data also provided evidence that there may be two distinct populations of *E. lata* in California. However, this distinction, made solely upon the basis of DNA sequence data, seems somewhat impractical given that isolates from both groups were capable of infecting grapevines, and that these isolates could not be distinguished from each other on the basis of morphology following growth in artificial culture.

### 1.9 Spectroscopy

Spectroscopy is a technique which is well suited for diagnostic applications because it fulfils the main requirements of a diagnostic test in that it is rapid, accurate and non-destructive. In spectroscopy, radiation is able to penetrate the specimen and allow information to be gathered regarding the presence or absence of a material, for example

a pathogen, in a sample. Spectroscopy involves the use of the absorption, emission or scattering of electromagnetic radiation to study the structure of the atoms or molecules of interest. Analysis of electromagnetic radiation which has been passed over a sample may be used to provide information on the chemical composition or structure of the sample.

Spectroscopy has not seen widespread use as a technique for early diagnosis of plant pathogens. However, near-infrared (NIR) spectroscopy has recently been used to detect *Fusarium oxysporum* and *Rhizopus stolonifer* spores on the surface of infected tomato plants (Hahn, 2002), for the early detection of both Rhizoctonia blight on bent-grass (Raikes & Burpee, 1998) and Phytophthora foot rot of citrus (Fletcher *et al.*, 2001). Also, Fourier transform infrared spectroscopy (FTIR) has been used to monitor the effects of the fungus *Guignardia aesculi* on horse chestnut leaves (Bertoluzza *et al.*, 1999).

Spectroscopic techniques have also been widely used to study diverse aspects of the biology of plants. One of the most widely used techniques in plant science has been NMR spectroscopy. This technique allows for the *in vivo* analysis of processes occurring in plant tissue, and has been used to assess fungal colonisation of fruit (Goodman, Williamson & Chudek, 1992; Williamson *et al.*, 1992), to detect physiological disorders in plants (Wang, Wang & Faust, 1988; Masuch *et al.*, 1991), to investigate carbon metabolism and uptake in mycorrhizal fungi (Bago *et al.*, 1999; Pfeffer *et al.*, 1999) and to analyse the structure and biosynthesis of fungal toxins (Caldas *et al.*, 1998). NMR has also been used to help elucidate the structure of both eutypine and eutypinol (Tey Rulh *et al.*, 1991; Deswarte *et al.*, 1994; Colrat *et al.*, 1999b). However, NMR is not a practical technique to use for the diagnosis of plant pathogens because it is time consuming and requires extensive sample preparation. Other spectroscopic techniques used in plant science include X-ray spectroscopy, which has been used to determine the composition of fungal cell components and for diagnosing toxicities and deficiencies in both leaf and seed tissue, and near infra red spectroscopy to analyse protein and moisture content of grains (Skerritt *et al.*, 1995).

## 1.10 Summary and objectives

*E. lata* is the causal agent of eutypa dieback of grapevine, a serious disease which leads to a gradual decline in production and the eventual death of infected vines in grape growing regions throughout the world. The disease causes a variety of foliar symptoms,

as well as a cankering and discolouration of woody tissue. It is believed that the foliar symptoms are due to the actions of either a fungal toxin named eutypine, or related compounds.

*E. lata* is difficult to identify on the basis of morphological characteristics when grown in culture. A prolonged delay of between 2 and 8 years following infection and the appearance of symptoms allows extensive colonisation of grapevine tissue to occur before the disease is detected.

The recommended method of controlling the disease is to remove all discoloured wood, as well as a 10 - 20 cm portion of healthy wood from infected vines. However, because little is known about the spread of the pathogen within vines, the efficacy of this technique remains unclear. No control agents are registered for the management of eutypa dieback in Australia and, whilst some chemicals are known to have preventative properties, no control agents are known to have a curative effect.

The objectives of this study were (1) to develop DNA-based techniques which would enable the rapid identification of *E. lata* in culture, (2) to develop DNA-based assays which would enable the rapid detection of the pathogen in infected wood and (3) to analyse secondary metabolite production by *E. lata* in order to identify a compound or compounds which could be used to detect the presence of the pathogen prior to the expression of foliar symptoms of the disease.

The development of molecular probes specific to the pathogen will prove a valuable tool in gathering information regarding the spread and location of the pathogen in vine tissue. In addition, these probes will have the potential to be used in assessing the effects of various chemical and biological control agents against *E. lata*. However, because of the prolonged delay between inoculation and symptom expression, these probes would not be suitable for the early diagnosis of the disease. Even once efficient control measures for eutypa dieback are developed, significant yield loss may still occur before these measures take effect. The development of early diagnostic techniques, which will enable the detection of the pathogen prior to the expression of foliar symptoms, will have the potential to be used in conjunction with control measures, and will therefore assist in minimising the effects of eutypa dieback on grapevines.

---

## Chapter 2 General materials and methods

---

In this section, materials and methods which were commonly used in this research are described. Any modifications of these methods are noted in the relevant chapter.

### 2.1 Collection and maintenance of *E. lata* isolates

Isolates collected in this study were obtained from perithecia on the surface of dead grapevine wood, or from the margins of cankers in infected vines. Ascospores were obtained from perithecia by soaking stromata for 1 h in sterile dd H<sub>2</sub>O, then suspending the wood above an empty 90 mm Petri dish over-night. Released ascospores were suspended in 200 µl sterile dd H<sub>2</sub>O, and spread over the surface of water agar in a 90 mm Petri dish. After incubation for 12-16 h at 25°C in the dark, single germinated ascospores were excised from the agar using a sterile scalpel, with the aid of a binocular microscope, and transferred to potato dextrose agar (PDA; Difco, USA, Appendix B). Mycelium was isolated from the margins of cankers by briefly surface sterilising the diseased tissue in a flame, then excising 5-10 chips (approximately 5 x 5 x 1 mm) from the margin of healthy and diseased wood, and incubating the chips on PDA in the dark at 25°C. Mycelium growing from wood-chips was transferred to fresh PDA and identified as *E. lata* on the basis of colony morphology (Carter, 1991). Single hyphal tips were excised from colonies identified as *E. lata* and transferred to fresh PDA. For long term storage, approximately 20 mycelial segments (5 x 5 mm) were excised from the actively growing margin of a colony on PDA, placed in 15 ml sterile dd H<sub>2</sub>O in McCartney bottles, and kept at 4°C. Cultures were routinely maintained on PDA in the dark at 25°C.

### 2.2 Fungal isolates

The isolates of *E. lata* and other fungi used in this study are listed in Table 2.1. These include isolates collected from infected grapevines in South Australia and those obtained from colleagues in other states of Australia and other countries.



**Table 2.1** Origin and source of *E. lata* and other fungal species used in this study

Isolate No.	Species	Source	Year of isolation	Origin
1765 <sup>a</sup>	<i>Botryosphaeria ribis</i>	<i>Vitis vinifera</i>	2000	Victoria
1735 <sup>a</sup>	<i>Cryptovalsa ampelina</i>	Perithecia, <i>V. vinifera</i>	2000	Eden Valley, SA
01017B <sup>a</sup>	<i>E. lata</i>	<i>V. vinifera</i>	2001	NSW
1776 <sup>a</sup>	<i>E. lata</i>	Perithecia, <i>V. vinifera</i>	2000	SA
200/2	<i>E. lata</i>	Mycelium, <i>V. vinifera</i>	2002	McLaren Vale, SA
200/3	<i>E. lata</i>	Mycelium, <i>V. vinifera</i>	2002	McLaren Vale, SA
83330 <sup>b</sup>	<i>E. lata</i>	<i>Prunus persica</i>	1983	SA
83339 <sup>b</sup>	<i>E. lata</i>	Mycelium, <i>Quercus</i> sp.	1983	SA
A166 <sup>a</sup>	<i>E. lata</i>	Mycelium, <i>V. vinifera</i>	2000	SA
AsW <sup>c</sup>	<i>E. lata</i>	Perithecia, <i>V. vinifera</i>	2000	Barossa Valley, SA
Bx 1-10 <sup>d</sup>	<i>E. lata</i>	<i>V. vinifera</i>	1990	France
CAB2 <sup>c</sup>	<i>E. lata</i>	Perithecia, <i>V. vinifera</i>	2000	Barossa Valley, SA
E 120 <sup>e</sup>	<i>E. lata</i>	Mycelium, <i>V. vinifera</i>	Unknown	California
E 125 <sup>e</sup>	<i>E. lata</i>	Mycelium, <i>V. vinifera</i>	Unknown	Italy
E 178 <sup>e</sup>	<i>E. lata</i> *	Mycelium, <i>Quercus lobata</i>	Unknown	California
E 1 <sup>e</sup>	<i>E. lata</i>	<i>V. vinifera</i>	Unknown	Australia
EL3 <sup>a</sup>	<i>E. lata</i>	<i>V. vinifera</i>	Unknown	South Africa
EL4 <sup>a</sup>	<i>E. lata</i>	<i>V. vinifera</i>	Unknown	South Africa
EVS <sup>a</sup>	<i>E. lata</i>	Mycelium, <i>V. vinifera</i>	2000	Eden Valley, SA
HT01 <sup>a</sup>	<i>E. lata</i>	Mycelium, <i>Prunus armeniaca</i>	2000	SA
IM 334 <sup>d</sup>	<i>E. lata</i>	<i>V. vinifera</i>	1996	Italy
JB16 <sup>a</sup>	<i>E. lata</i>	Mycelium, <i>V. vinifera</i>	2000	SA
Knox <sup>a</sup>	<i>E. lata</i>	Mycelium, <i>V. vinifera</i>	2000	Knoxfield, Vic
M266 <sup>f</sup>	<i>E. lata</i>	Perithecia, <i>V. vinifera</i>	1999	France
M279 <sup>f</sup>	<i>E. lata</i>	Perithecia, <i>Prunus armeniaca</i>	1999	Victoria
M280 <sup>f</sup>	<i>E. lata</i>	Perithecia, <i>V. vinifera</i>	1999	Victoria
M295 <sup>f</sup>	<i>E. lata</i>	Perithecia, <i>V. vinifera</i>	1999	Victoria
M302 <sup>f</sup>	<i>E. lata</i>	Perithecia, <i>V. vinifera</i>	1999	Victoria
M335 <sup>f</sup>	<i>E. lata</i>	Perithecia, <i>V. vinifera</i>	1999	Victoria
N01	<i>E. lata</i>	Perithecia, <i>V. vinifera</i>	2000	Nuriootpa, SA
N03	<i>E. lata</i>	Perithecia, <i>V. vinifera</i>	2000	Nuriootpa, SA
N04	<i>E. lata</i>	Perithecia, <i>V. vinifera</i>	2000	Nuriootpa, SA
N07	<i>E. lata</i>	Perithecia, <i>V. vinifera</i>	2000	Nuriootpa, SA
N08	<i>E. lata</i>	Perithecia, <i>V. vinifera</i>	2000	Nuriootpa, SA
Nuri <sup>a</sup>	<i>E. lata</i>	Mycelium, <i>V. vinifera</i>	2000	Nuriootpa, SA
Pear #1	<i>E. lata</i>	Perithecia, pear	1981	SA
SS12 <sup>b</sup>				
PP 496 <sup>d</sup>	<i>E. lata</i>	<i>V. vinifera</i>	1999	Spain
RB 440 <sup>d</sup>	<i>E. lata</i>	<i>V. vinifera</i>	1997	France

Isolate No.	Species	Source	Year of isolation	Origin
SS 357-2 <sup>b</sup>	<i>E. lata</i>	Perithecia, <i>Genista</i> sp.	1984	SA
SS 357-3 <sup>b</sup>	<i>E. lata</i>	Perithecia, <i>Genista</i> sp.	1984	SA
SS1#1 <sup>g</sup>	<i>E. lata</i> *	Perithecia, <i>V. vinifera</i>	1999	New Zealand
SS1#3 <sup>g</sup>	<i>E. lata</i> *	Perithecia, <i>V. vinifera</i>	1999	New Zealand
SS1#9 <sup>g</sup>	<i>E. lata</i> *	Perithecia, <i>V. vinifera</i>	1999	New Zealand
SS10 <sup>b</sup>	<i>E. lata</i>	Perithecia, <i>V. vinifera</i>	1981	SA
SS11 <sup>b</sup>	<i>E. lata</i>	Perithecia, <i>V. vinifera</i>	1981	SA
SS2 <sup>b</sup>	<i>E. lata</i>	Perithecia, <i>V. vinifera</i>	1981	SA
SS4 <sup>b</sup>	<i>E. lata</i>	Perithecia, <i>V. vinifera</i>	1981	SA
SS6 <sup>b</sup>	<i>E. lata</i>	Perithecia, <i>Viburnum opulus</i>	1984	SA
1739 <sup>a</sup>	<i>Phellinus punctatus</i>	<i>V. vinifera</i>	2000	Victoria
1740 <sup>a</sup>	<i>Phellinus</i> sp.	<i>V. vinifera</i>	2000	WA
1750 <sup>a</sup>	<i>Phaeoacremonium chlamydosporum</i>	<i>V. vinifera</i>	2000	Victoria
1775	<i>Phaeoacremonium aleophilum</i>	<i>V. vinifera</i>	2000	Victoria
1780 <sup>h</sup>	<i>Phomopsis viticola</i>	<i>V. vinifera</i>	2001	Adelaide Hills, SA
1785 <sup>i</sup>	<i>Uncinula necator</i>	<i>V. vinifera</i>	1997	SA
C2	unidentified ascomycete	Perithecia, <i>V. vinifera</i>	2000	Eden Valley, SA
C2a	unidentified ascomycete	Perithecia, <i>V. vinifera</i>	2000	Eden Valley, SA
EV01	unidentified ascomycete	Perithecia, <i>V. vinifera</i>	2000	Eden Valley, SA
EV02	unidentified ascomycete	Perithecia, <i>V. vinifera</i>	2000	Eden Valley, SA
EV03	unidentified ascomycete	Perithecia, <i>V. vinifera</i>	2000	Eden Valley, SA
W01	unidentified basidiomycete	Perithecia, <i>V. vinifera</i>	2000	Warrriparinga, SA
W05	unidentified basidiomycete	Perithecia, <i>V. vinifera</i>	2000	Warrriparinga, SA
W07	unidentified basidiomycete	Perithecia, <i>V. vinifera</i>	2000	Warrriparinga, SA

South Australia (SA), New South Wales (NSW), Victoria (Vic), Western Australia (WA)

a Isolates provided by Dr Mette Creaser

b Isolates obtained from the culture collection of Dr Maurice Carter

c Isolates provided by Ms Sharmini John

d Isolates provided by Dr Jean-Pierre Peros

e Isolates provided by E. & J. Gallo Winery

f Isolates provided by Dr Mary Cole

g Isolate provided by Dr Peter Long

h Isolate provided by Dr Belinda Rawnsley

i Isolate provided by Dr Belinda Stummer

\* Indicates isolate was received as *E. lata*, but subsequently shown to be a species other than *E. lata*

## 2.3 Growth of isolates for DNA extraction

Mycelium was grown and prepared for DNA extraction as follows: 250 ml conical flasks containing 80 ml of sterile Vogel's liquid growth medium (Appendix B, Vogel, 1964) were inoculated with 6-8 squares of mycelium (3 x 3 mm) excised from the margins of actively growing colonies on PDA, and incubated in the laboratory under natural light at 20-25°C for 10-14 days in stationary conditions. Cultures were then filtered through Whatman® no. 4 filter paper with a vacuum, and the mycelial mat was rinsed with 400 ml sterile dd H<sub>2</sub>O, frozen in liquid nitrogen and stored at -70°C until required.

## 2.4 DNA extraction from fungal mycelium

DNA was extracted using a modification of the method of Péros *et al.* (1996). Frozen mycelium was placed in liquid nitrogen and ground to a fine powder using a mortar and pestle. Ground mycelium (80 mg) was transferred to a 2 ml microcentrifuge tube and 800 µl of extraction buffer (appendix A) was added. The resulting suspension was vortexed for 5 s and incubated at 65°C for 30 min. An equal volume of phenol:chloroform:*iso*-amyl alcohol (25:24:1) was added and the suspension mixed on a rotating disc for 10 min. The suspension was centrifuged at 14,000 rpm for 20 min and, following collection of the supernatant, 10 µl of RNase A (10 mg/ml) was added. After incubation at 37°C for 30 min, 0.2 vol of CTAB and 0.8 vol of chloroform:*iso*-amyl alcohol (24:1) were added and mixed by inversion. The suspension was centrifuged at 14,000 rpm for 15 min, the supernatant transferred to a new microcentrifuge tube, and 0.2 vol of 10 M ammonium acetate was added. The suspension was mixed by inversion and 2 vol of ice cold 100% ethanol were added and mixed by inversion. Following incubation at -20°C for 2 h, the solution was centrifuged for 10 min at 14,000 rpm, the ethanol decanted, and the pellet washed in 70% ethanol and re-centrifuged. Ethanol was removed using an aspirator and the DNA pellet was re-suspended in 40 µl of Tris-EDTA (TE) buffer (Appendix A).

The quantity and quality of DNA was assessed by subjecting a 1 µl aliquot to electrophoresis in a 0.8% agarose gel in Tris-Acetate-EDTA (TAE) buffer (Appendix A) for 1.5 h at 60 V. Gels were stained with ethidium bromide and visualised using a UV transilluminator. DNA quantity was estimated against a λ *Hind* III DNA ladder (Roche Diagnostics, Germany) containing known quantities of DNA.

## 2.5 Southern hybridisation

### 2.5.1 Southern transfer of genomic DNA to nylon membranes

Approximately 500-700 ng of DNA was digested with a restriction enzyme overnight at 37°C. Complete digestion was confirmed by subjecting an aliquot to electrophoresis in a 1% agarose gel in TAE buffer and visualising the DNA smear in UV light following staining with ethidium bromide. Digested DNA (500 ng total) was then subjected to electrophoresis in a 1% agarose gel in TAE buffer at 30 V overnight. Following staining with ethidium bromide and visualisation under UV light, the gel was placed in denaturing solution (appendix A) on a shaking platform for 30 min, and then transferred to neutralising solution (appendix A) on a shaking platform for a further 30 min. DNA was transferred overnight to a positively charged nylon membrane (Amersham, U.K) using the techniques of Southern (1975) and Sambrook *et al.* (1989). Membranes were rinsed briefly in 5 x SSC (Appendix A), and DNA fixed to the membrane using a Bio-Rad® GS Gene Linker™ UV chamber (Bio-Rad Inc., USA) at 150 mJ. Membranes were then sealed between polyethylene sheets and stored at 4°C until required.

### 2.5.2 Preparation and digestion of plasmid DNA

DNA clones were recovered from storage at -70°C by streaking colonies onto Luria-Bertani agar with 100 µg/ml ampicillin (LBamp, Appendix A) and incubating overnight at 37°C. A single colony was transferred to 10 ml LBamp broth (Appendix A) and incubated at 37°C for 12-16 h with constant shaking (180 rpm). Plasmid DNA was isolated using the Wizard® Plus Minipreps DNA purification system (Promega, USA) according to the manufacturer's instructions, then digested overnight with *Pst* I restriction enzyme (Roche Diagnostics). Complete digestion and the presence of inserts was confirmed by subjecting an aliquot to electrophoresis in a 1.2% agarose gel in Tris-Borate-EDTA buffer (TBE, appendix A) and visualising under UV light following staining with ethidium bromide.

When clones were to be transferred to nylon membranes, the remainder of the digested plasmid preparations were separated by electrophoresis in a 1.2% gel in TBE buffer at 60 V for 4 h, and transferred to nylon membranes as in section 2.5.1. When required for use as probes in radiolabelling, digested plasmid preparations were separated by electrophoresis in a 1% TAE gel, and plasmid inserts were isolated from the gels and

purified using the GeneClean II kit (Bio-101 Inc., USA) according to the manufacturer's instructions. DNA concentration was estimated following comparison with a known quantity of  $\lambda$  DNA digested with *Hind* III on a 1% agarose gel in TBE buffer.

### 2.5.3 DNA hybridisation techniques

Nylon membranes, placed between two nylon mesh sheets, were soaked in 2 x SSC (Appendix A) and transferred to a 30 cm long Hybaid<sup>®</sup> glass cylinder (Boehringer Mannheim, Germany). Excess SSC was drained from the cylinder and 10 ml of pre-hybridisation buffer (Appendix A) was added. The bottle was then placed in a Hybaid<sup>®</sup> rolling oven at 65°C and incubated for a minimum of 6 h.

Insert DNA (50 ng) was added to 3  $\mu$ l random hexamer primer, and the volume made up to 10  $\mu$ l with dd H<sub>2</sub>O. The solution was denatured by boiling for 5 min, then chilled on ice for 5 min. Oligolabelling buffer (12.5  $\mu$ l, Appendix A), 30  $\mu$ Ci <sup>32</sup>P-dCTP and 1.5 units Klenow DNA polymerase were added, and the solution was gently mixed by pipetting. Following incubation for 30-45 min at 37°C, unincorporated nucleotides were separated from labelled DNA as follows. A mini-column was prepared by compressing a small quantity of glass wool into the base of a 5 <sup>3</sup>/<sub>4</sub>" glass Pasteur pipette and filling the column with Sephadex G-100 suspended in TES buffer (appendix A). The Sephadex gel was rinsed with 2 vol TE buffer and the labelling reaction mixture pipetted onto the top of the column. As soon as drops leaving the column reached a radioactivity greater than 150 cps, the labelled probe was collected in a microcentrifuge tube, until radioactivity peaked at 1500-2000 cps. When the radioactivity started to decline, effluent was collected in a fresh tube. The microcentrifuge tube containing the radio-labelled probe was placed on ice, and the column, along with the effluent in tubes one and three, was discarded. Sonicated herring sperm (1 mg) was then added to the labelled probe and the mixture placed in a boiling water bath for 5 min. Following incubation on ice for 5 min, the labelling reaction mixture was pipetted directly into the glass hybridisation cylinder and incubated with rotation at 65°C for 12-16 h.

Labelled membranes were washed successively for 20 min in 2 x SSC, 0.1% SDS; 1 x SSC, 0.1% SDS; 0.5 x SSC, 0.1% SDS and, if necessary, 0.2 x SSC, 0.1% SDS at 65°C with shaking in a water bath. Washed membranes were blotted briefly between paper towels, than placed between polyethylene sheets and exposed to X-ray film (X-Omat, Kodak, USA) at -70°C to obtain an auto-radiographic image.

---

## Chapter 3 Development of SCAR markers specific to *E. lata*

---

### 3.1 Introduction

Traditional methods used for epidemiological studies and for the identification of plant pathogenic fungi, which involve the isolation of pathogens into pure culture and their subsequent identification, are often both time consuming and laborious. Although *E. lata* can be identified by the presence of perithecia on dead infected wood in areas with an annual rainfall of greater than 350 mm, perithecia are not produced in artificial culture, or in areas with an annual rainfall of less than 350 mm (Carter, 1957a; Ramos *et al.*, 1975). Therefore, identification must often be carried out on the basis of the morphology of the anamorph in culture. Under these circumstances it may be difficult, or impossible, to distinguish *E. lata* from other ascomycetes (Glawe *et al.*, 1982). In addition, other micro-organisms present in grapevine wood may grow more rapidly than *E. lata* in culture, hence false negative results are easily obtained when attempting isolation from infected wood. As a result, as many as 25 wood-chips may need to be taken from each infected sample in order to detect the presence of the pathogen reliably (Petzoldt *et al.*, 1981).

Since the 1970s, a variety of techniques has been developed in order to detect and identify plant pathogens rapidly and reliably. These techniques include immunology-based detection systems (Schaad, 1979; Dewey and Priestley, 1994; van de Koppel and Schots, 1994; Dewey and Thornton, 1995), isozyme analysis (Kerssies *et al.*, 1994) and nucleic acid-based methods (Schesser *et al.*, 1991; Paran and Michelmore, 1993; Annamalai *et al.*, 1995; Li *et al.*, 1999; Förster and Adaskaveg, 2000). The relative merits of these techniques were discussed in Chapter 1.

SCAR markers can be used to amplify DNA of the pathogen of interest in a mixture of plant and fungal DNA. In addition, because the presence of the pathogen is indicated by the amplification of a single fragment of DNA of known size, results are easy to interpret. SCAR markers are developed by elucidating the sequence of a DNA fragment specific to the species of interest, for example a fragment generated by RAPD amplification, then designing primer pairs which will amplify only this region of DNA. As discussed in section 1.8.3.3, the SCAR technique has become a favoured method for

detecting plant pathogens (Paran and Michelmore, 1993; McDermott *et al.*, 1994; Leclerc Potvin *et al.*, 1999).

Since this project commenced, researchers in France have developed SCAR markers specific to *E. lata* (Lecomte *et al.*, 2000). In addition, *E. lata* specific PCR primers based on ribosomal DNA (rDNA) internal transcribed spacer (ITS) sequence data have been developed by both French (Lecomte *et al.*, 2000) and American (Irelan *et al.*, 1999) researchers. These primers were obtained and tested for their specificity towards Australian isolates of the pathogen. The American primers were obtained under a Material Transfer Agreement between the Cooperative Research Centre for Viticulture and E. & J Gallo Winery, Modesto, California. These primers are the subject of pending and allowed patents in various countries, including the United States and Australia.

The major aim of the work reported in this chapter was to develop SCAR markers, for use in a PCR-based assay, which were capable of rapidly and reliably identifying *E. lata* and distinguishing it from other grapevine-inhabiting fungi. In addition, the genetic variability of 11 isolates obtained as *E. lata*, which were also used in the analysis of secondary metabolite production by *E. lata* (see chapters 6 and 7), was assessed using 10 RAPD primers.

## 3.2 Methods

### 3.2.1 RAPD amplification and primer selection

Genomic DNA was extracted from selected isolates listed in Table 2.1 as outlined in section 2.4. A total of 86 primers from Operon Technologies RAPD™ 10-mer kits OPA, OPD, OPE, OPJ, OPU and OPAM were initially screened with *E. lata* isolates M280 and N01, as well as one morphologically similar isolate, W01, which was subsequently shown to belong to a genus other than *Eutypa*.

RAPD-PCR amplification reactions were carried out in a total volume of 25 µl containing approximately 20 ng of fungal genomic DNA. Each reaction contained 0.1 vol of 10 x thermophilic buffer (500 mM KCl, 100 mM Tris-HCl (pH 9.0), 1% Triton®X-100), 2 mM MgCl<sub>2</sub>, 200 µM each of dATP, dCTP, dGTP, dTTP (Roche Diagnostics, Germany), 30 ng of primer (Operon Technologies, USA) and 1 unit of *Taq*

DNA polymerase (Promega, USA). Negative controls, using sterile distilled water instead of DNA, were included in each experiment. Amplification was carried out in 0.6 ml thin-walled PCR tubes, using a Corbett Research PC-960 thermocycler.

Amplification was achieved by an initial denaturation step of 4 min at 94°C, followed by 36 cycles of 1 min at 93°C, 1 min at 38°C and 1 min at 72°C, with a final extension period of 6 min at 72°C. The same amplification conditions were used by Péros *et al.* (1996) for RAPD analysis of French populations of *E. lata*. Amplification products were detected by loading a 10 µl aliquot of each reaction product on a 1.2% agarose gel in 0.5 x TBE buffer (Appendix A), and separating by gel electrophoresis for 1 h at 80 volts. PCR products were visualised by staining with ethidium bromide and viewing using a UV transilluminator. A molecular size standard was used in each experiment (either a pGEM<sup>®</sup> molecular marker (Promega, USA), a 1 kb ladder (Promega) or a 200 bp DNA ladder (Geneworks, Australia)).

Following the preliminary screening, primers which resulted in intense bands of the same size in both *E. lata* isolates, but not W01, were screened with an additional 12 *E. lata* isolates, and with 13 other fungi isolated from grapevine. On the basis of these data, two DNA fragments, apparently specific to *E. lata*, were selected for cloning and characterisation.

### 3.2.2 Cloning and characterisation of RAPD fragments

Specific DNA fragments from three *E. lata* isolates (M302, N04 and SS6) were selected for cloning. Fragments were excised from a 0.8% TAE agarose gel and purified using a GeneClean II kit (Bio-101, USA) according to the manufacturer's instructions. Purified PCR products were ligated into the pGEM<sup>®</sup>-T Easy Vector system (Promega), according to the manufacturer's instructions. All solutions and media are listed in appendix A.

DNA molar ratios for ligation reactions were calculated using the following formula:

$$\frac{\text{ng of vector} \times \text{insert size (kb)}}{\text{vector size (kb)}} \times \text{insert:vector ratio} = \text{ng of insert required}$$

Insert:vector ratios of 1:1, 1:3 and 3:1 were tested. Each ligation reaction consisted of 50 ng pGEM<sup>®</sup>-T Easy Vector (Promega), 3 units T4 DNA ligase, 5 µl 2 x rapid ligation buffer and DNA at the required insert:vector ratio. The volume was adjusted to 10 µl with dd H<sub>2</sub>O, and reactions were mixed by pipetting and incubated overnight at 4°C.



The ligation reactions were used to transform high efficiency competent cells of *Escherichia coli* strain JM 109 (Promega, USA). Three control reactions were also prepared:

- 1) A positive control using a 542 bp fragment of control DNA (pGEM<sup>®</sup> *luc* DNA) to test whether the ligation reaction was successful;
- 2) A background control where insert DNA was omitted to determine the number of colonies resulting from undigested vector;
- 3) A transformation control using 25 ng circular pUC19 DNA to ascertain the efficiency of the competent cells.

For transformations, 2 µl of each ligation reaction mixture were transferred to a sterile 50 ml Falcon<sup>®</sup> tube (Becton Dickinson Labware, USA) on ice. Competent cells were thawed in an ice bath and 50 µl of cells added to each tube. Reactions were gently mixed and stored on ice for 20 min, then heat shocked for 50 s in a 42°C water bath. Reactions were immediately returned to ice for 2 min, then 950 µl of SOC medium (Appendix A) was added. Cultures were incubated at 37°C for 1.5 hours with shaking at 150 rpm. Aliquots (100 µl) of each culture were plated onto duplicate LB/amp/IPTG/X-Gal plates (Appendix A) and incubated for 16-24 h at 37°C. Recombinant bacteria were visible as white colonies on this medium, whereas non-recombinant bacteria formed blue colonies. White bacterial colonies, presumed to contain insert DNA, were transferred to fresh LB/amp/IPTG/X-gal plates, arranged in grid formation, using a sterile wooden toothpick (Grunstein and Hogness, 1975). An un-transformed (blue) colony was transferred to the last position on the grid. These plates were incubated at 37°C overnight then stored at 4°C for future use. Twelve recombinant colonies, two from each isolate/RAPD primer combination, were selected and grown in LBamp broth at 37°C overnight in an orbital shaker at 180 rpm. Aliquots (1 ml) of putative transformant cultures were then stored at -70°C in 15% glycerol. Plasmid DNA was extracted from overnight LBamp broth cultures using a Promega Wizard<sup>®</sup> Plus Minipreps DNA purification system according to the manufacturer's instructions.

*Eco* R1 restriction digests were carried out on purified plasmid preparations to confirm the presence of inserts in putative transformant colonies. Digestions were performed using 20 ng of plasmid DNA, 20 units of restriction enzyme (Roche Diagnostics), 0.1 vol of 10 x restriction buffer and water to a final volume of 20 µl. Digests were

incubated overnight at 37°C. A 10 µl aliquot of each digest was separated by gel electrophoresis (see section 3.2.1).

Undigested plasmid DNA from selected transformant colonies was adjusted to 250 ng/µl and analysed by automated DNA sequencing (Flinders University of South Australia DNA Sequencing Core facility), in forward and reverse directions, using the universal primers M13F and M13R (Messing, 1983), with an Applied Biosystems ABI 373XL Automated Sequencer.

### 3.2.3 Primer design

Forward and reverse sequences for each isolate were aligned using the computer package Chromas version 1.45 (Technelysium, Australia). Aligned sequence data were then imported into BioManager.com provided by ANGIS. Sequences from each of the three selected isolates were aligned with each other using Clustal W (Thompson *et al.*, 1994). The GenBank DNA and protein sequence database was searched for homology to other sequences using the BlastN and BlastX programs, respectively (Altschul *et al.*, 1997).

The primer design software package OLIGO version 6.57 (Molecular Biology Insights Inc; USA) was used to design primers specific to the characterised regions. All primers were synthesised by Geneworks Pty Ltd, Adelaide.

### 3.2.4 Validation of SCAR markers

Newly synthesised primers were used to amplify *E. lata* DNA as follows: an initial denaturation step of 2 min at 94°C was followed by 37 cycles of 30 s at 94°C, 30 s at 65°C and 1 min at 72°C, with a final extension of 10 min at 72°C. Amplification reactions were as outlined above (section 3.2.1), however, primers were used at 0.2 µM each. Primers were initially tested against isolates M280, N04 and SS6, and then one primer pair was tested with a further 21 *E. lata* isolates, and 11 other fungi isolated from grapevine, as well as with grapevine DNA. The 11 isolates, which were used in the analysis of secondary metabolite production by *E. lata* (see Chapter 6), selected on the basis of geographic origin and host species, were analysed as a separate group.

### 3.2.5 Assessment of SCAR and ITS markers developed in France and California

The six primer pairs described by Lecomte *et al.* (2000) (Table 3.1) were synthesised by Geneworks Pty Ltd. Primers were tested for their efficacy in amplifying DNA of 24 isolates of *E. lata* and 14 other grapevine-inhabiting fungi of Australian origin. PCR conditions were as outlined in section 3.2.1, except that primers were used at a final concentration of 0.2  $\mu$ M each (Lecomte *et al.*, 2000). Amplification conditions consisted of an initial denaturation period of 2 min at 94°C, followed by 37 cycles with a 30 s denaturation at 94°C, a 30 s annealing at a specific temperature (Table 3.1) and a 1 min extension at 72°C, followed by a final 10 min extension at 72°C (Lecomte *et al.*, 2000). Amplification products were separated by gel electrophoresis (section 3.2.1).

**Table 3.1** Sequence data and annealing temperatures of PCR primers designed for specific amplification of *E. lata* DNA (Lecomte *et al.*, 2000)

Primer pair	Sequence of primer (5'-3')	Expected PCR product size (bp)	Annealing Temp (°C)
SCA 10A SCA 10B	TAGTGGTGTGTCAGTGAAAGG GTGCTAAAGCTTAAAATCCC	350	60
SCB 02A SCB 02B	AATCGATGTGAGAGATGG AGGTCAATGATAGCCAAC	700	60
SCD 18A SCD 18B	GAGTACGTTGGTACAATGG ACTCTCTCTCGTCTTTTGC	450	60
Lata 1 Lata 2-1	GAGCTACCCTGTAGCCCGCTG CTATCCGGAGATAGGCTCCC	350	65
Lata 1 Lata 2-2	GAGCTACCCTGTAGCCCGCTG GACGTCAGCCGTGACACACC	385	65
Lata 3 Lata 2-1	GCCTACCCGCCGGTGGACAC CTATCCGGAGATAGGCTCCC	281	65

Samples of primers developed by researchers at E. & J. Gallo winery in California and the required reaction conditions were obtained under an intellectual property agreement, however, primer sequence data were not made available. These primers were assessed using the same isolates as for assessment of the French primer pairs. PCR mixtures were as previously outlined (section 3.2.1), however, the MgCl<sub>2</sub> concentration was reduced to 1.5 mM. Primers were suspended in TE buffer to obtain a stock solution as recommended by researchers at E. & J. Gallo, and a total volume of 0.25  $\mu$ l of both forward and reverse primer was added to each 25  $\mu$ l reaction. As recommended by the

developers of this primer pair, amplification conditions consisted of an initial denaturation period of 3 min at 94°C, followed by 35 cycles of 94°C for 1 min, 50°C for 1 min and 72°C for 1 min, and a final 5 min extension period at 72°C.

### **3.2.6 Genetic variation within *E. lata***

Genetic variation among the group of 11 isolates obtained as *E. lata* (see section 3.1), was assessed using RAPD primers. Eight isolates were obtained from grapevine in Australia, California, France, Italy and New Zealand, two isolates were from apricot in Australia, and one from Valley oak in California. Four of the isolates (E1, E120, E125 and E178) had previously been subjected to genetic analysis using AFLP and rDNA ITS analysis (DeScenzo *et al.*, 1999).

Ten RAPD primers, namely OPA 02, OPD 08, OPD 18, OPE 03, OPJ 20, OPU 16, OPAM 06, OPAM 07, OPAM 07 and OPAM 16, all of which gave distinct bands for all *E. lata* isolates in the initial screenings of RAPD primers (see section 3.2.1), were selected, and amplification by PCR conducted as outlined in section 3.2.1. Each reaction was duplicated, providing two replicates for each primer/isolate combination.

#### **3.2.6.1 Analysis of banding patterns**

Only PCR products with a molecular weight of between 0.5 and 4 kb were included in the analysis. DNA fragments which consistently gave an intense band when visualised under UV light were defined as major bands. All major bands were scored as being either present or absent. Minor bands were only scored if another isolate produced a major band of corresponding molecular weight. This was because although the presence and absence of bands produced by a single primer is often assumed to be independent (Black, 1996), this may not always be the case. For example, it has previously been illustrated that preferential amplification of some bands may interfere with the amplification of other bands (Wilkerson *et al.*, 1993). Hence, it is likely that DNA fragments of the same molecular weight may show different degrees of amplification between isolates. It was therefore assumed that major and minor bands which co-migrated on a gel were homologous.

Following scoring of bands as either present or absent, data were entered into a spreadsheet to generate a table showing the haplotype of each isolate. Data were then imported into the computer program TREECON (Van de Peer and De Wachter, 1994). Distance matrices were generated using the algorithms of Nei and Li (Nei and Li, 1979),

and Link (Link *et al.*, 1995), and neighbour joining trees were generated within the TREECON computer package. Statistical significance of trees was assessed by generating 1,000 random trees and determining the statistical significance of trees using the bootstrap technique (Felsenstein, 1985) within the TREECON program.

### 3.3 Results

#### 3.3.1 RAPD primer screening

Clearly visible DNA fragments were evident in 65 of the amplification reactions conducted using 84 different RAPD primers, following screening with *E. lata* isolates M280 and N04 and unidentified isolate W01. Intense DNA fragments of the same size and visible only in the two *E. lata* isolates were generated following amplification with 33 of these 65 primers. Eighteen of the 33 primers which were used to amplify distinct bands of the same size and high intensity in both *E. lata* isolates were selected and subjected to additional screening using 14 *E. lata* isolates and 13 other fungi isolated from grapevine. Of the amplification reactions conducted using these 18 primers, six led to the generation of DNA fragments which were present for all *E. lata* isolates but not for any other species, five generated fragments of the same size from both *E. lata* and non-*E. lata* isolates, and seven generated fragments of the same size for some, but not all *E. lata* isolates. These results are summarised in Table 3.2.

**Table 3.2** Results of RAPD primer screening conducted using 18 RAPD primers with 14 *E. lata* and 13 non-*E. lata* fungal isolates

Not specific <sup>a</sup>	Not conserved <sup>b</sup>	Specific <sup>c</sup>
OPA 04	OPAM 06	OPAM 02
OPE 02	OPAM 09	OPAM 07
OPJ 20	OPAM 15	OPU 16
OPU 05	OPJ 13	OPE 05
OPAM 16	OPE 03	OPE 06
	OPE 11	OPJ 04
	OPJ 05	

<sup>a</sup> Bands of the same size produced in *E. lata* and non-*E. lata* isolates.

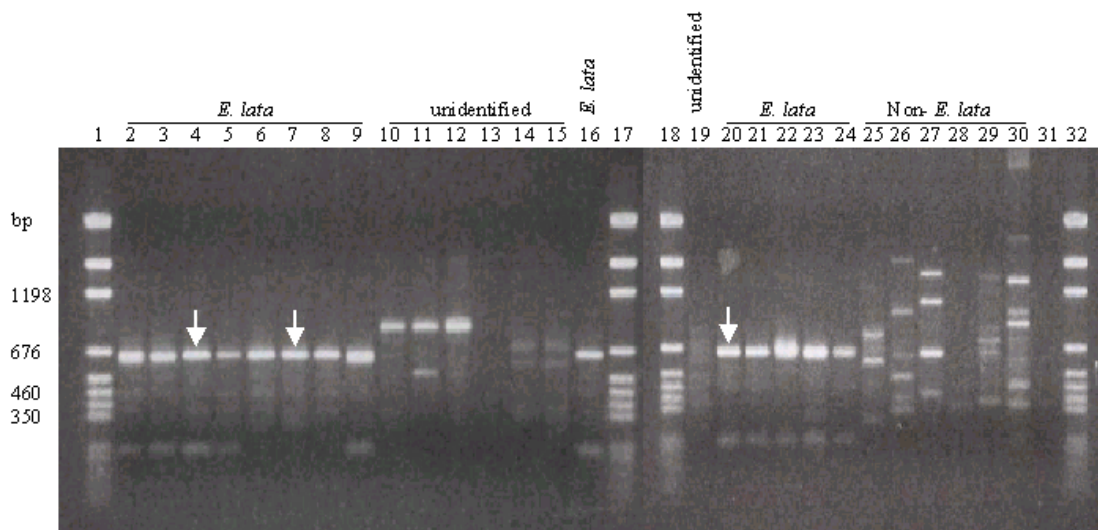
<sup>b</sup> Bands not present in all *E. lata* isolates.

<sup>c</sup> Bands present in all *E. lata* isolates but no other isolates

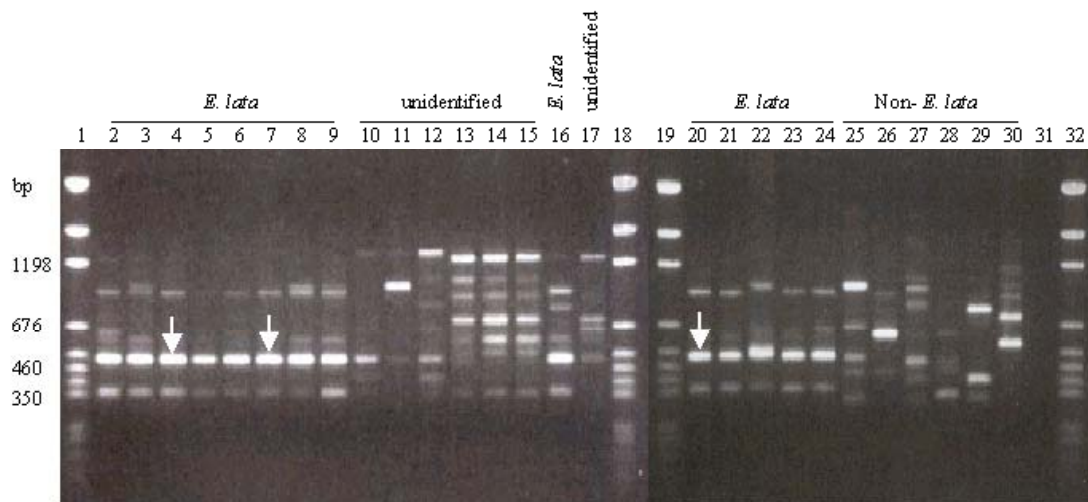
Of the six reactions which generated DNA fragments specific to, and present in, all *E. lata* isolates, amplifications using RAPD primers OPAM 02 (Figure 3.1) and OPAM 07 generated DNA fragments of the same size and similar intensity in all isolates. Although amplification reactions using the other four primers did generate fragments of the same size in all *E. lata* isolates, in certain isolates these bands were extremely faint.

Amplification reactions conducted using RAPD primers OPA 04, OPE 02, OPJ 20, OPU 05 and OPAM 16 generated non-specific bands, present in all *E. lata* isolates as well as in either isolate W01, W05, W07, EV01, EV02, C2A, EV03, 1739, 1740, 1750 or 1775, or in a combination of these isolates. In particular, amplification using RAPD primer OPAM 16 (Figure 3.2) generated a band of approximately 500 bp with high intensity in all *E. lata* isolates, but also generated a faint band of a similar size in six non-*E. lata* isolates, namely W01, W05 and W07, C2A, 1739 and 1750. However, the overall RAPD profiles of these six isolates were clearly different to those generated with the isolates of *E. lata*. Given these differences between isolates, it was considered that the 500 bp band present in non-*E. lata* isolates was unlikely to share sequence homology with the same size DNA fragment detected in *E. lata* isolates.

The 500 bp DNA fragment amplified in all *E. lata* isolates, as well as some other isolates, when using primer OPAM 16, and a 650 bp *E. lata*-specific fragment generated using primer OPAM 02 were selected for further analysis. The specific bands from three representative isolates (M302, N04 and SS6) were excised from agarose gels then cloned and sequenced. RAPD-PCR banding patterns of all isolates analysed with these primers are shown in Figures 3.1 and 3.2.



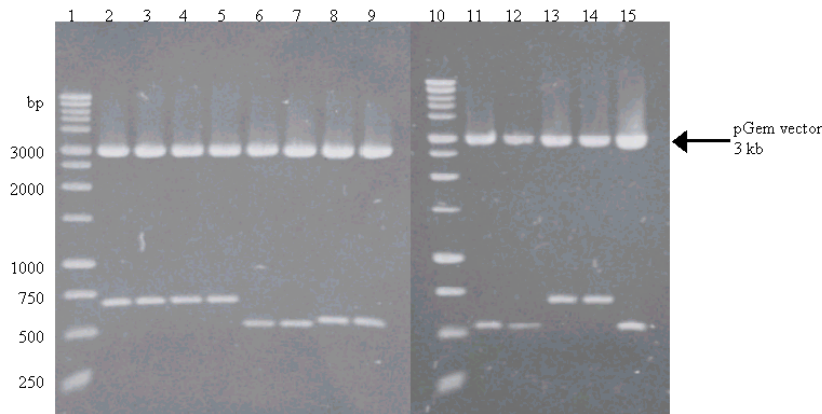
**Figure 3.1** PCR amplification of genomic DNA from *E. lata* and non-*E. lata* isolates using RAPD primer OPAM 02. Lanes 1, 17, 18, 32 pGEM<sup>®</sup> DNA marker; lanes 2-16 genomic DNA from isolates M280, M295, M302, N01, N03, N04, N07, N08, W01, W05, W07, EV01, EV02, EV03, cab2; lanes 19-30 genomic DNA from isolates C2a, SS6, SS10, SS11, SS 357-2, SS 357-3, 1739, 1740, 1750, 1765, 1775, 1780; lane 31 dd H<sub>2</sub>O. Arrows indicate 650 bp DNA fragments selected for cloning.



**Figure 3.2** PCR amplification of genomic DNA from *E. lata* and non-*E. lata* isolates using RAPD primer OPAM 16. Lanes 1, 18, 19, 32 pGEM<sup>®</sup> DNA marker; lanes 2-17 genomic DNA from isolates M280, M295, M302, N01, N03, N04, N07, N08, W01, W05, W07, EV01, EV02, EV03, cab2, C2a; lanes 20-30 genomic DNA from isolates SS6, SS10, SS11, SS 357-2, SS 357-3, 1739, 1740, 1750, 1765, 1775, 1780; lane 31 dd H<sub>2</sub>O. Arrows indicate 500 bp DNA fragments selected for cloning.

### 3.3.2 Cloning and sequencing of PCR products

The specific DNA fragments from three isolates (see Figures 3.1 and 3.2) were cloned and sequenced. Transformation reactions were initially carried out with the 500 bp product amplified from isolate N04 using RAPD primer OPAM 16. For this fragment, the optimal insert:vector ratio was 3:1, hence, this ratio was used in all subsequent transformations. Six transformant bacterial colonies, two from each isolate/primer combination, were selected and plasmid DNA was isolated from overnight LBamp broth cultures. Digestion of plasmid DNA with *Eco* R1 and subsequent gel electrophoresis confirmed that all transformants contained inserts of the expected sizes (i.e. 500 or 650 bp, Figure 3.3). For each isolate/primer combination, one recombinant colony was selected, and the insert DNA sequenced following isolation of plasmid DNA. Each of the six recombinant cultures was stored in 15% glycerol at -70 °C (see section 3.2.2).



**Figure 3.3** *E. lata* recombinant plasmid DNA digested with *Eco* R1, showing the presence of inserts of the expected sizes of 650 bp (RAPD fragment OPAM 02) and 500 bp (RAPD fragment OPAM 16). Lanes 1, 10 200 bp DNA ladder; lanes 2, 3 isolate SS6, RAPD fragment OPAM 02; 4, 5 N04, RAPD fragment OPAM 02; 6, 7 SS6, RAPD fragment OPAM 16; 8, 9 M302, RAPD fragment OPAM 16; 11, 12 N04, RAPD fragment OPAM 16; 13, 14 M302, RAPD fragment OPAM 02, lane 15, pGEM<sup>®</sup> control insert DNA.

### 3.3.3 Sequence analysis

The RAPD fragment generated by amplification of *E. lata* DNA with primer OPAM 02 was 663 bp long in isolates M302 and N04. However, there was a 5 bp deletion in isolate SS6, hence the resulting sequence was 658 bp in length. Although there were some single base pair substitutions between isolates, no significant differences in sequence were observed among the isolates tested. The fragment generated following amplification of *E. lata* DNA using primer OPAM 16 was 505 bp long in all three isolates and, apart from an occasional single base substitution, there were no significant differences between isolates. Aligned sequence data for both fragments and all three isolates are given in Figures 3.4 and 3.5. No significant homology to any known nucleotide or protein sequences was observed among sequences available in the GenBank database.

### 3.3.4 Primer design

Aligned sequence data from isolate M302 were used to generate forward and reverse primer pairs, designed using the primer design software package OLIGO version 6.57. High stringency design parameters were used to design three SCAR primer pairs for each DNA fragment amplified using RAPD primers OPAM 02 and OPAM 16. Sequence information for the six selected primer pairs is given in Tables 3.3 and 3.4.







**Table 3.3** Sequence data of SCAR primers designed to amplify the PCR product derived from RAPD primer OPAM 02 and expected size of the amplified DNA fragment.

Primer pair	Sequence of primer (5'-3')	Primer length (bp)	Expected product size (bp)
634L20 230U21	ACGAGTGACAAGCGATCAAAT GCCTTACCGAAATAGACCAA	21 20	424
634L21 19U20	CGGGTAGGGTTAGGTACGGA GGCCTTACCGAAATAGACCAA	20 21	636
634L21 12U20	TGGTGGACGGGTAGGGTTAG GGCCTTACCGAAATAGACCAA	20 21	643

**Table 3.4** Sequence data of SCAR primers designed to amplify the PCR product derived from RAPD primer OPAM 16 and expected size of the amplified DNA fragment.

Primer pair	Sequence of primer (5'-3')	Primer length (bp)	Expected product size (bp)
404L21 227U21	TGATAGCCTGCCGTCATCGTC CCGCCAGCTAAGGACATTGAG	21 21	198
219L21 23U19	GGTGAAGTTATGCGCTCAA CGGCAGGCTATCATAGTAGAA	19 21	217
228L18 34U21	GCGCTCAATGCATGAACTAAC CGATGACGGCAGGCTATC	21 18	212

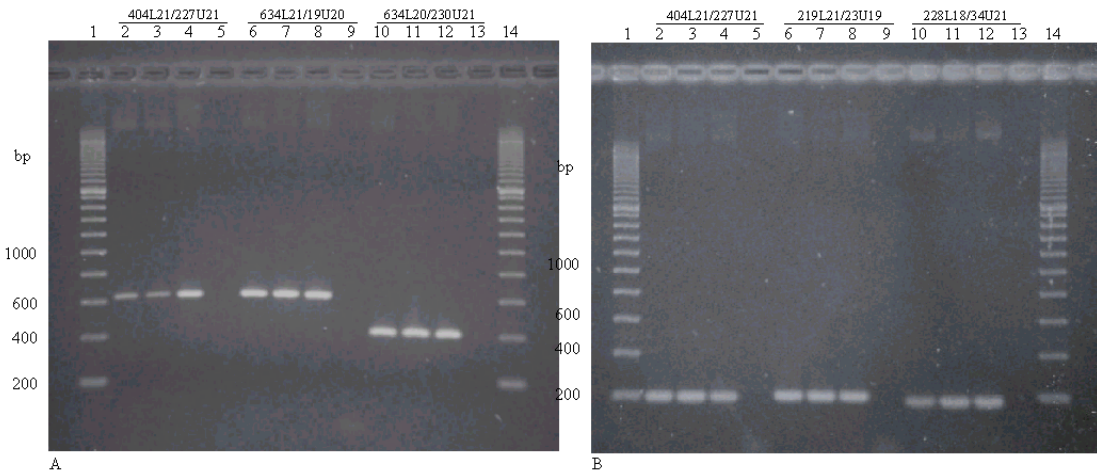
### 3.3.5 Validation of SCAR markers

Amplification reactions conducted using all six SCAR primer pairs and *E. lata* isolates M280, N04 and SS6 generated DNA fragments of the predicted size (refer to Tables 3.3 and 3.4) in each case (Figure 3.6).

Primer pair 634L21/12U20, derived from RAPD primer OPAM 02, was selected for further analysis. Amplification reactions conducted using 24 *E. lata* isolates, 11 other fungi isolated from grapevine and grapevine DNA generated a band of the expected size (approximately 650 bp) for all *E. lata* isolates but not for any other fungal species tested (Figure 3.7).

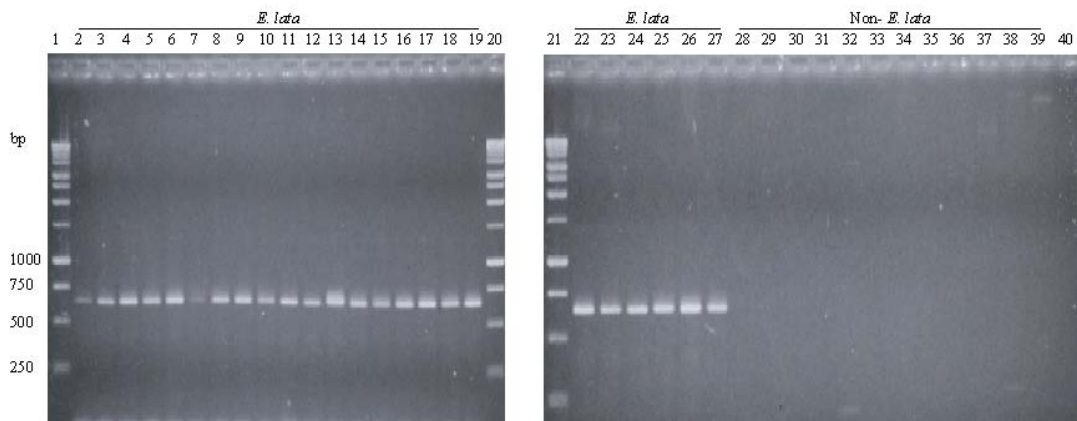
DNA amplification conducted using this primer pair in conjunction with genomic DNA from the group of 11 *E. lata* isolates, revealed PCR products in only nine isolates (Figure 3.8). The two isolates which did not generate amplification products originated

from California (isolate E178, obtained from Valley oak) and New Zealand (isolate SS1#1, obtained from grapevine).



**Figure 3.6** **A** PCR amplification of DNA from three *E. lata* isolates using SCAR primer pairs derived from RAPD fragment OPAM 02. Lanes 1, 14 200 bp DNA ladder; lanes 2, 6, 10 M280; lanes 3, 7, 11 N04; lanes 4, 8, 12 SS6; lanes 5, 9, 13; dd H<sub>2</sub>O.

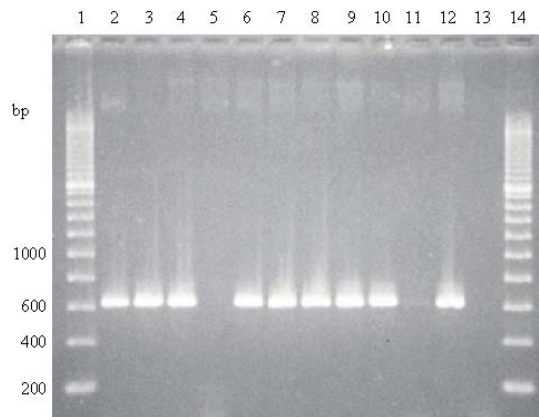
**B** PCR amplification of DNA from three *E. lata* isolates using SCAR primer pairs derived from RAPD fragment OPAM 16. Lanes 1, 14 200 bp DNA ladder; lanes 2, 6, 10 M280; lanes 3, 7, 11 N04; lanes 4, 8, 12 SS6; lanes 5, 9, 13 dd H<sub>2</sub>O.



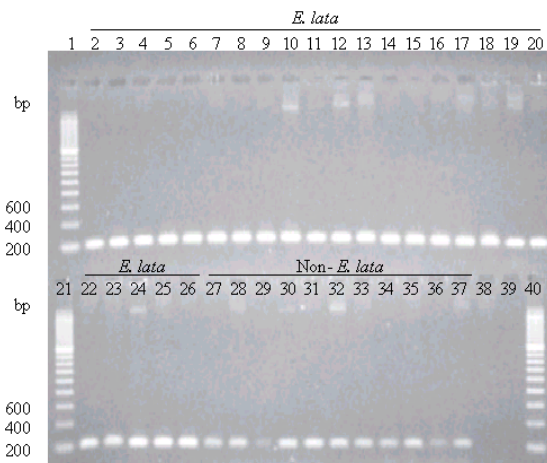
**Figure 3.7** PCR amplification of DNA from *E. lata* and non-*E. lata* isolates using SCAR primer pair 634L21/12U20. Lanes 1, 20, 21 Promega 1 kb DNA ladder; lanes 2-19, M280, M295, M302, N01, N03, N04, N07, N08, AsW, cab2, SS2, SS4, SS6, SS10, SS11, Nuri, HT01, Knox; lanes 22-39, JB16, A166, P#1ss12, EVS, 1776, SS357-3, C2a, C2b, W01, W05, EV01, 1785, 1735, 1739, 1740, 1750, 1765, 1775, grapevine, dd H<sub>2</sub>O.

Given the inability of primer pair 634L21/12U20 to amplify DNA from all 11 isolates, amplification reactions were also conducted using the other five SCAR primer pairs developed here in order to assess whether these were capable of amplifying DNA from all 11 isolates. As for results obtained using primer pair 634L21/12U20, the remaining primer pairs derived from RAPD fragment OPAM 02 did not amplify DNA from the two anomalous isolates, although amplification was successful in the remaining nine isolates. Of the primers derived from the OPAM 16 RAPD fragment, primer pairs

404L21/227U21 and 228L18/34U21 amplified DNA from all isolates with the exception of SS1#1 from New Zealand, and primer pair 219L21/23U19 amplified DNA from all 11 isolates. Consequently, amplification reactions were conducted using primer pair 219L21/23U19 and the same 26 isolates used to validate SCAR primer pair 634L21/12U20. Results of this amplification illustrated that the primer pair was not specific to *E. lata*, and detected all fungal isolates tested, but not grapevine DNA (Figure 3.9).



**Figure 3.8** PCR amplification of genomic DNA from *E. lata* using SCAR primer pair 634L21/12U20. Lanes 1 & 14 Geneworks 200 bp DNA ladder; lanes 2-13; E1, E120, E125, E178, M266, M279, M280, M335, N04, SS1#1, SS6, ddh20.

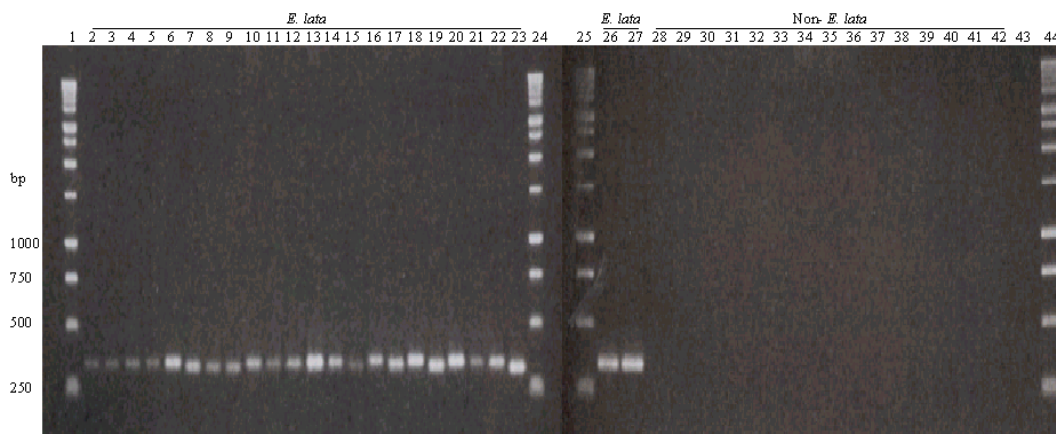


**Figure 3.9** PCR amplification of *E. lata* and non-*E. lata* DNA using SCAR primer pair 219L21/23U19. Lanes 1, 21, 40 Geneworks 200 bp ladder; lanes 2-20 and 22-39; M280, M295, M302, N01, N03, N04, N07, N08, AsW, cab2, SS2, SS4, SS6, SS10, SS11, Nuri, HT01, Knox, JB16, A166, P#1ss12, EVS, 1776, SS357-3, C2a, C2b, W01, W05, EV01, 1735, 1785, 1739, 1740, 1750, 1765, 1775, grapevine, dd H<sub>2</sub>O.

### 3.3.6 Assessment of specificity of French PCR primers towards Australian isolates of *E. lata*

When using the three ITS-based PCR primers (Lecomte *et al.*, 2000), amplification products of the expected size were present for all 24 *E. lata* isolates screened. However, products of the expected size were also observed for isolates of fungi other than *E. lata* (data not shown). For example, amplifications conducted using primer pair Lata 3 and Lata 2-1 generated bands of the expected size (281 bp) in non-*E. lata* isolates W07, 1735 and 1750. Use of primer pairs Lata 1 and Lata 2-1 as well as Lata 1 and Lata 2-2 led to amplification products of the expected size (350 bp and 385 bp, respectively) in the three isolates listed above, as well as in isolates C2a, C2c, EV01, EV02, EV03, W01 and W05. Hence, these primer pairs were not considered to be specific to isolates of *E. lata* originating in Australia in the conditions used here.

Amplifications conducted using SCAR primer pair SCA 10A and SCA 10B (Lecomte *et al.*, 2000) generated PCR products of the expected size (350 bp) from DNA of all *E. lata* isolates but not from the other isolates screened (Figure 3.10). These primers were, therefore, considered specific to the Australian population of *E. lata*.

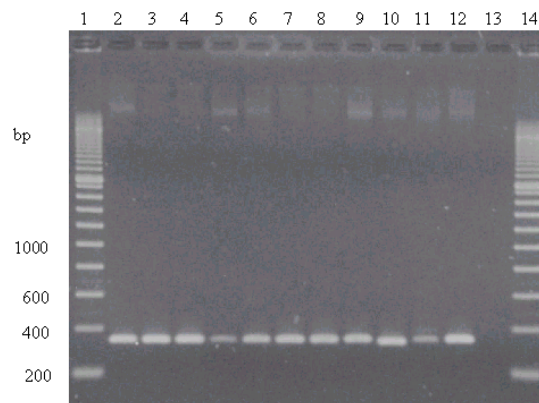


**Figure 3.10** PCR amplification of *E. lata* and non-*E. lata* genomic DNA using French SCAR primer pair SCA10A and SCA10B (Lecomte *et al.*, 2000). Lanes 1, 24, 25, 44 Promega 1 kb DNA ladder; lanes 2-23 M280, M295, M302, N01, N03, N04, N07, N08, AsW, cab2, SS2, SS4, SS6, SS10, SS11, SS357-3, P#1 ss12, A166, EVS, HT01, JB16, Knox; lanes 26-43, Nuri, 1776, C2a, C2c, EV01, EV02, EV03, W01, W05, W07, 1785, 1735, 1739, 1740, 1750, 1765, 1775, dd H<sub>2</sub>O.

Of the remaining SCAR primer pairs, no amplification products were visible when using primer pair SCB 02A and SCB 02B in conjunction with DNA from either *E. lata* or non-*E. lata* isolates. Amplification of DNA using primer pair SCD 18A and SCD 18B resulted in bands of the expected size (450 bp) in 14 of 24 *E. lata* isolates screened

but not in any other isolates. Hence, neither of these primer pairs was considered specific towards the Australian population of *E. lata*.

Amplification reactions were subsequently conducted using DNA from the group of 11 isolates (section 3.1), with the specific primer pair SCA 10A and SCA 10B. A PCR product of the expected size was observed in all 11 isolates in this instance (Figure 3.11), however the amplified DNA was fainter in isolates E178 and SS1#1.



**Figure 3.11** PCR amplification of DNA from 11 *E. lata* isolates using SCAR primers SCA 10A and SCA 10B. Lane 1 & 14 Geneworks 200 bp DNA ladder; lanes 2-13 E1, E120, E125, E178, M266, M279, M280, M335, N04, SS1#1, SS6, ddh20.

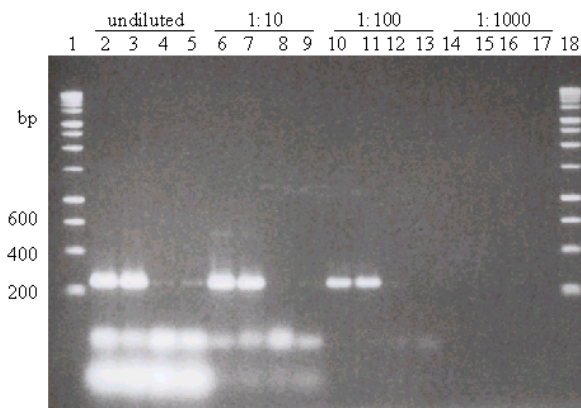
### 3.3.7 Assessment of specificity of Californian ITS primers towards Australian isolates of *E. lata*

Amplification of DNA using Californian primers, in conditions recommended by the researchers who developed these primers, resulted in the generation of the expected 280 bp product in all fungal species screened as well as in negative controls. This was initially attributed to the contamination of PCR reagents with *E. lata* DNA, however, repeated reactions carried out using fresh reagents consistently led to the generation of bands of the expected size in all reactions. It was then suspected that the stock solution of the primers may have become contaminated with *E. lata* DNA, however, reactions carried out with a fresh batch of primers indicated that this also was not the case.

Information regarding the primer concentration was not available. An experiment was set up to test the effects of primer concentration on the PCR, using 1:10, 1:100 and 1:1,000 dilutions of the primer solution, as well as primers at the concentration recommended by E. & J. Gallo researchers. These reactions were carried out using DNA from *E. lata* isolates M280 and N01 as well as isolate 1765 (*Botryosphaeria ribis*) and a negative (dd H<sub>2</sub>O) control. Both the 1:10 and the 1:100 dilutions generated bands



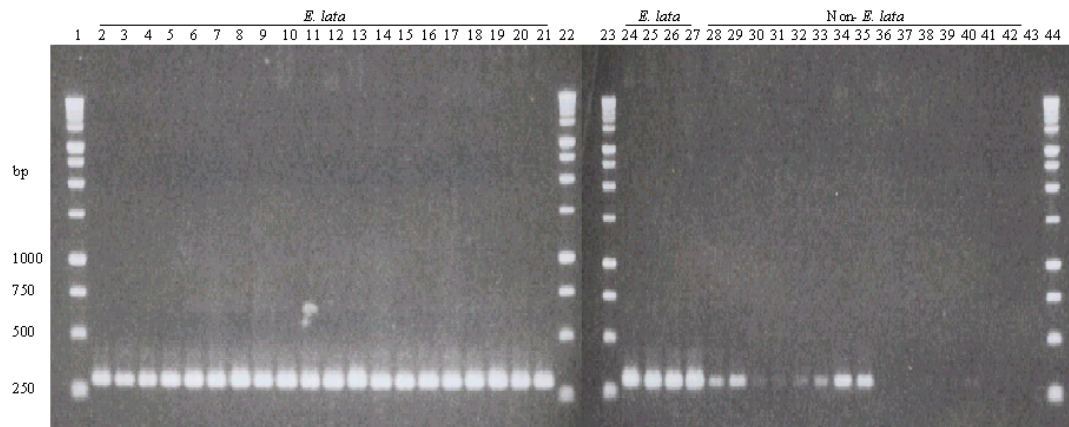
of 280 bp only from the reaction mixtures containing DNA of *E. lata*. No PCR products were generated using the 1:1,000 dilution of primer. When used at the recommended concentration, faint bands were also present in isolate 1765 and the water control (Figure 3.12). The formation of excessive primer-dimers was also evident when both the recommended and 1:10 dilutions of the primer stock solution were used (Figure 3.12). It was concluded that excessive primer concentrations in the reaction mixture led to the generation of primer-dimer complexes which were, by coincidence, the same size as the expected PCR product.



**Figure 3.12** PCR amplification of DNA using a dilution series of Californian ITS-based PCR primers. Lanes 1 and 18 Geneworks 200 bp ladder; lanes 2, 6, 10, 14 M280; lanes 3, 7, 11, 15 N04; lanes 4, 8, 12, 16 1765; lanes 5, 9, 13, 17 dd H<sub>2</sub>O.

For all further reactions conducted using this primer pair, a 1:100 dilution of the original stock was used. This concentration was selected rather than the 1:10 dilution because of reduced primer-dimer formation observed at the lower concentration. Screening of isolates carried out using the 1:100 dilution of the primer revealed bands of the expected size (280 bp) in all *E. lata* isolates. However, PCR products of the same size were also present in isolates C2a, C2c, EV01, EV02, EV03, W01, W05, W07 and 1750 (Figure 3.13). These primers were, therefore, not considered to be specific to *E. lata* in the conditions used here.

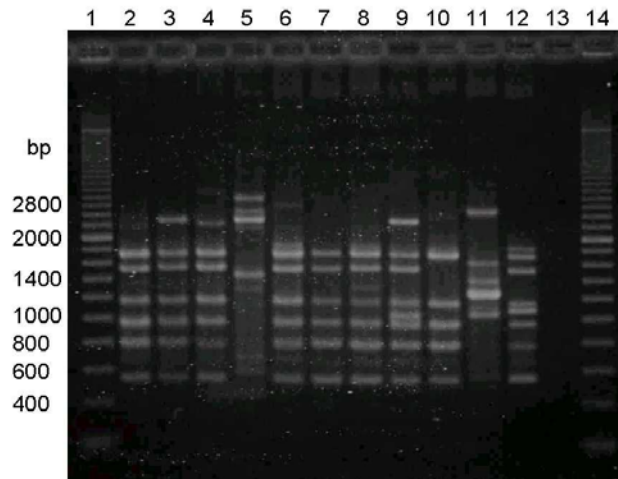




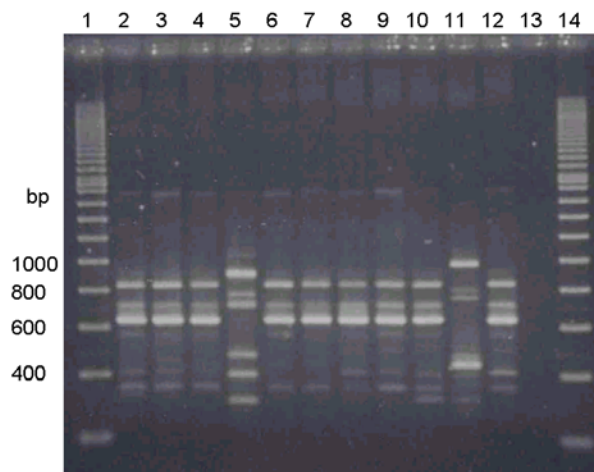
**Figure 3.13** PCR amplification of genomic DNA from *E. lata* and non-*E. lata* isolates using Californian ITS-based primers. Lanes 1, 24, 25, 44 Promega 1 kb DNA ladder; lanes 2-21 M280, M295, M302, N01, N03, N04, N07, N08, AsW, cab2, SS2, SS4, SS6, SS10, SS11, SS357-3, P#1 ss12, A166, EVS, HT01, lanes 24-43, JB16, Knox, Nuri, 1776, C2a, C2c, EV01, EV02, EV03, W01, W05, W07, 1785, 1735, 1739, 1740, 1750, 1765, 1775, dd H<sub>2</sub>O.

### 3.3.8 Genetic variation within *E. lata*

A total of 107 scoreable bands was generated following screening of the 11 isolates with 10 RAPD primers. Figures 3.14 and 3.15 show representative gels obtained following PCR amplification using primers OPJ 20 and OPAM 07. No DNA fragments were present in all isolates, although one band was present in 10 isolates (all except SS1#1), and 21 bands were present in nine isolates (all except E178 and SS1#1). Eleven different haplotypes were identified among the 11 isolates. Amplification of DNA from isolate SS1#1 yielded only one DNA fragment which was present in any other isolate. This band was present in all isolates except N04 and E178. Likewise, isolate E178 yielded only two DNA fragments that were observed for other isolates. One of these fragments was present in DNA from all isolates except SS1#1, the other only in DNA from isolates E125 and N04.

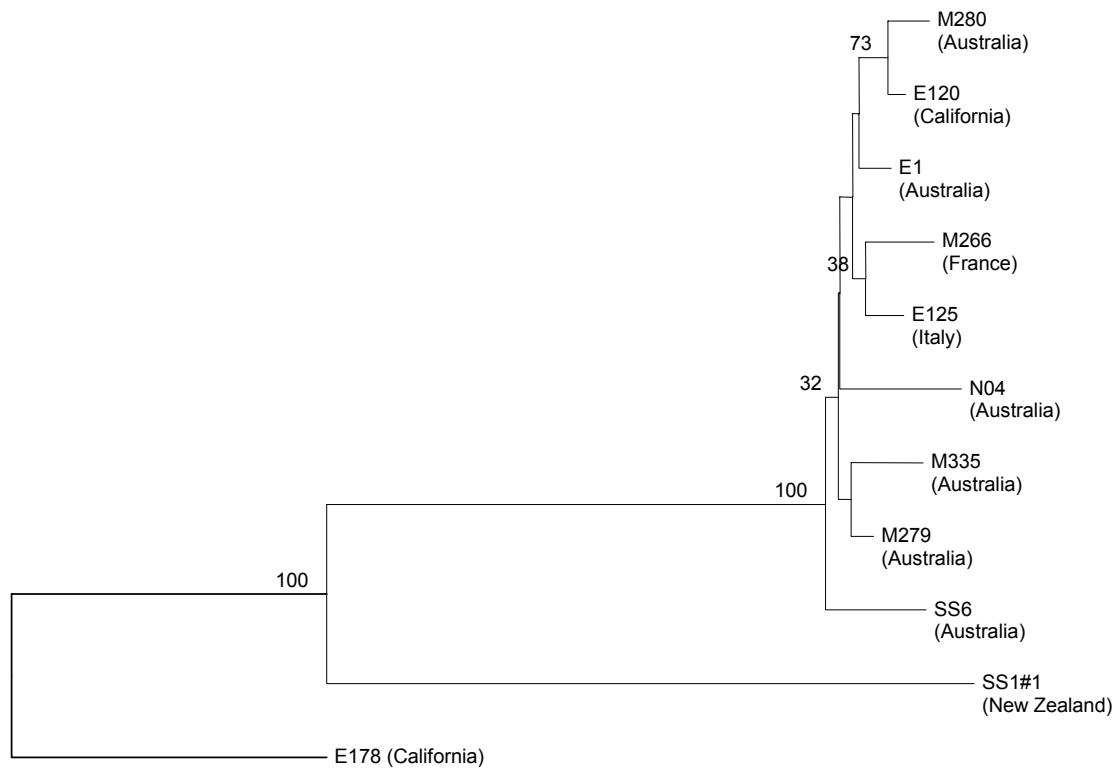


**Figure 3.14** RAPD banding patterns obtained following PCR using RAPD primer OPJ 20 and 11 isolates of *E. lata*. Lanes 1 and 14, 200 bp DNA ladder; lanes 2-11, *E. lata* isolates E1, E120, E125, E178, M266, M279, M280, M335, N04, SS1#1, SS6; lane 13 dd H<sub>2</sub>O.

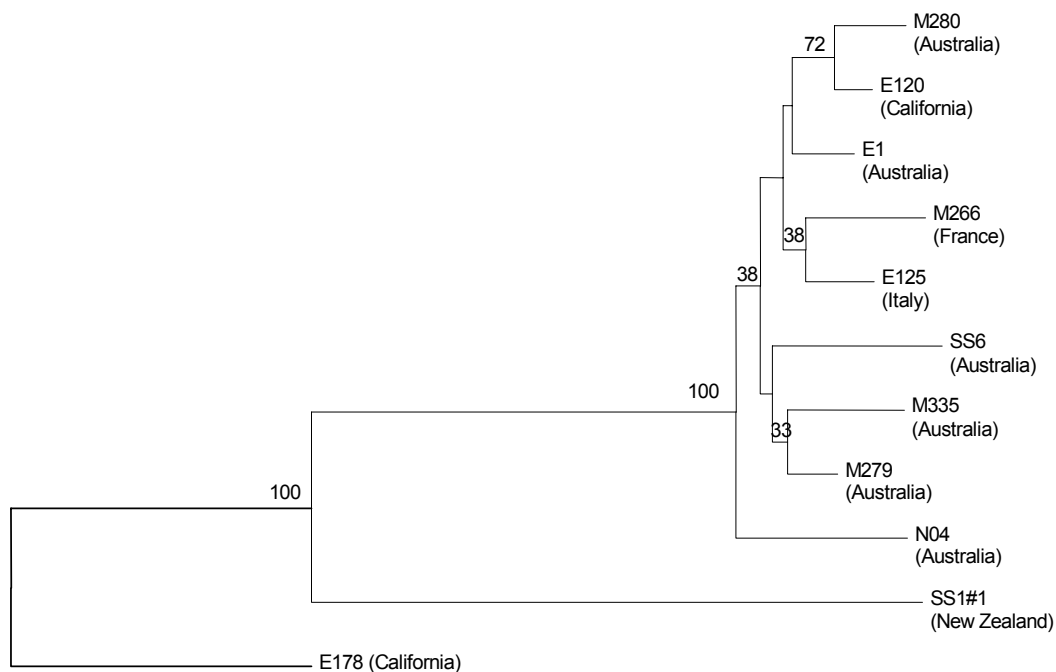


**Figure 3.15** RAPD banding patterns obtained following PCR using RAPD primer OPAM 07 and 11 isolates of *E. lata*. Lanes 1 and 14, 200 bp DNA ladder; lanes 2-11, *E. lata* isolates E1, E120, E125, E178, M266, M279, M280, M335, N04, SS1#1, SS6; lane 13 dd H<sub>2</sub>O.

When constructing phylogenetic trees, isolate E178, now believed to be a species other than *E. lata* (see section 3.4), was defined as the outgroup. Although the two algorithms used to calculate distances resulted in the generation of trees with slightly different topologies, within each tree the same major monophyletic groupings were resolved (Figures 3.16 and 3.17). The phylogenetic trees indicated that isolate SS1#1 was significantly different from all other isolates. However, the remaining nine isolates were placed in a single distinct group, which was strongly supported by bootstrap analysis (Figures 3.16 and 3.17). With the exception of isolates E120 and M280, whose grouping was supported with a bootstrap value of approximately 70%, no other groupings of isolates were supported by bootstrap values of over 50% (Figures 3.16 and 3.17).



**Figure 3.16** Neighbour joining tree generated using TREECON, showing RAPD data from 11 isolates of *E. lata*. Isolate E178 was specified as the outgroup. Distances were calculated using the algorithm of Nei and Li (1979). Bootstrap values greater than 30% are given.



**Figure 3.17** Neighbour joining tree generated using TREECON, showing RAPD data from 11 isolates of *E. lata*. Isolate E178 was specified as the outgroup. Distances were calculated using the algorithm of Link *et al.* (1995). Bootstrap values greater than 30% are given.

### 3.4 Discussion

As would be expected for an out-crossing fungal population, the initial RAPD analysis revealed considerable variation among isolates of *E. lata*, with 11 of the 18 primers that were subjected to intensive screening leading to the amplification of PCR products which were present in DNA from all *E. lata* isolates. However, of these 11 primers, only five led to the amplification of conserved DNA fragments which were specific to the pathogen. Of the 18 RAPD primers selected for more intensive screening, five generated PCR products from DNA of isolate W01 which were the same size as fragments detected in *E. lata* isolates. This was despite the fact that the initial amplification using these 18 primers did not generate detectable PCR products in this isolate. This result highlights the variability of the RAPD procedure, and the need for reactions to be replicated when using this technique.

Although RAPD-PCR is well suited to analysing many individuals quickly within a population, a drawback is that co-migrating bands on gels are not necessarily homologous (Ouellet and Seifert, 1993; Pillay and Kenny, 1995), although this often is the case (Haemmerli *et al.*, 1992; Smith *et al.*, 1994; Fabré *et al.*, 1995). In the present study, sequence analysis of two different RAPD fragments, derived from three isolates of *E. lata*, indicated that the fragments were homologous, with the exception of some single base pair substitutions and, in one instance, a five base pair deletion. The subsequent amplification of SCAR products of the expected size from 24 Australian isolates of the pathogen, as well as from isolates originating in California, Italy and France, supported the suggestion that these RAPD fragments were homologous within *E. lata*.

Of the three isolates for which sequence data were obtained, SS6 and N04 were isolated from grapevine in South Australia, in 1981 and 2000, respectively, and isolate M302 was obtained from grapevine in Victoria in 2000. It appears that the sequences have remained largely unaltered over a period of 26 years, and are present in isolates obtained from different geographical regions. This indicates that the SCAR sequences may be derived from a relatively conserved region of DNA and, as such, would be suitable for use as a specific marker for the pathogen over time.

The ability of the SCAR markers derived from RAPD primer OPAM 02 to amplify DNA from all Australian isolates of *E. lata* tested, which were obtained from various

host species and locations over a period of 20 years, as well as isolates from California, France and Italy, but not from any other fungal species, suggests that these markers are specific to *E. lata*. However, this primer pair was not capable of detecting either isolate E178 (Valley oak, California), or SS1#1 (grapevine, New Zealand). Of the seven PCR primer pairs developed by other researchers, only one (SCAR markers SCA10A and SCA10B, Lecomté *et al.*, 2000) had the same degree of specificity towards Australian isolates of *E. lata* as the primers developed in this study. Interestingly, this primer pair was capable of detecting the anomalous isolates from New Zealand and California. It should be noted, however, that amplification of DNA using the French SCAR primer pair resulted in bands that were fainter in isolates E178 and SS1#1 than in the other nine isolates.

Although the two anomalous isolates were received as *E. lata*, the results of this study and recent research carried out in California and New Zealand, suggest that this may not be the case. The Californian isolate, E178, was collected from Valley oak and initially identified, presumably on the basis of colony morphology, as *E. lata*. However, rDNA ITS region sequence analysis carried out by DeScenzo *et al.* (1999) showed this isolate, along with seven other isolates originating from Valley oak, grapevine or madrone, to be grouped apart from 58 other isolates of *E. lata*. Similar results were obtained when the same isolates were subjected to AFLP analysis (DeScenzo *et al.*, 1999). On the basis of these data, it was suggested that isolate E178, along with the other seven isolates in this group, should be re-classified as *Eutypa armeniaca*. Furthermore, when attempting to replicate the ITS sequence analysis of DeScenzo *et al.* (1999), Californian researchers were unable to confirm that isolate E178 was a member of the genus *Eutypa* and suggested that this isolate was, in fact, a *Diatrype* species (W.D. Gubler, *pers. com.* February 2003). New Zealand researchers, who studied six fungi isolated as *E. lata*, including SS1#1, stimulated the production of perithecia of these isolates in laboratory culture. Analysis of the perithecia revealed that each ascus contained 19-38 ascospores, as opposed to the eight which are characteristic of *E. lata* (Long *et al.*, 2003). The *Eutypa*-like ascomycete *Cryptovalsa ampelina* produces perithecia on 1 year-old grapevine prunings as well as on older grapevine wood (Ferreira, 1988). This species, which produces 32 ascospores per ascus, is morphologically indistinguishable from *E. lata* in culture, but can be distinguished on the basis of fatty acid analysis (Ferreira and Augustyn, 1989). Comparison of ITS sequences obtained from isolate SS1#1 and *C. ampelina* revealed significant homology between these isolates (P. Long, *pers. com.*,

April 2003) It therefore seems probable that the New Zealand isolate SS1#1 may have been misidentified originally on the basis of somatic characteristics in culture. This result indicates that these isolates were not *E. lata*, but instead belong to some other species which is morphologically similar when grown in artificial culture.

The lack of specificity of the French and Californian ITS-derived primers may reflect genetic variation between populations of *E. lata* obtained from different geographic locations. Lecomte *et al.* (2000) tested 60 *E. lata* isolates and 36 other fungal species from France, Italy and Spain, and demonstrated that all three primer pairs showed a high degree of specificity towards *E. lata*. However, in this study, DNA fragments of the expected size were also observed for species other than *E. lata*. Similar results were observed with the Californian ITS-based primer pair. Notably, faint bands of the expected size were obtained from a Victorian isolate of *Phaeomoniella chlamydosporum* when conducting amplification reactions using both the French and Californian primer pairs, although the French and Californian researchers had also screened these primers against *P. chlamydosporum* and did not observe any PCR product. Lecomte *et al.* (2000) noted that the ITS sequence from which these primers were derived did share significant (91%) homology with the corresponding rDNA regions of *Xylaria cubensis*. It is possible that there may also be a degree of homology with other fungi and, if this was the case with the Australian population of *P. chlamydosporum*, for example, faint bands could be expected to result from partial binding of the primers to similar regions in the genome of *P. chlamydosporum*.

Of the three French SCAR primer pairs, only one pair was capable of detecting all *E. lata* isolates in this study. However, the generation of DNA fragments from isolates E178 and SS1#1 suggested that these primers also lack specificity to *E. lata*. The inability of primer pair SCB 02A and SCB 02B to amplify *E. lata* DNA in the current study suggests that this region of the genome may not be present in the Australian isolates tested here. Similarly, the observation that the remaining SCAR primer pair (SCD 18A and SCD 18B) detected only 14 of 24 Australian *E. lata* isolates indicates that this region of the genome may not be present in all isolates within the Australian population of *E. lata*. It should be noted, however, that the amplification using the primer pairs developed by other researchers was carried out in a model of thermocycler different from that used in those studies. It is, therefore, possible that some of the faint bands observed in DNA from isolates other than *E. lata* could be eliminated by

optimising the PCR conditions for the thermocycler used in this study, for example, by changing the annealing temperature.

Analysis of genetic variation among 11 isolates of *E. lata* revealed significant differences between isolates E178 and SS1#1 and the remaining nine isolates. Isolate SS1#1 had only one DNA fragment in common with other isolates, whereas isolate E178 had two bands which were present in other isolates. The differences between these two isolates and the remaining nine isolates of *E. lata* support the hypothesis that these isolates are not *E. lata*. The nine isolates now considered to be *E. lata* did not form groups on the basis of geographic origin. For example, the two most similar isolates were M280 (Australia) and E120 (California). These results are similar to those obtained by other researchers. For example, Péros *et al.* (1996) analysed 18 isolates of *E. lata* from a range of geographic locations using the RAPD technique, and observed that there was no correlation between isolate origin and RAPD banding pattern, with certain French isolates of the pathogen being more closely related to isolates obtained from other countries than to other French isolates. The observation that the nine isolates of *E. lata* analysed here all had different RAPD haplotypes is in accordance with observations of Péros *et al.* (1997) who used the RAPD technique to analyse 55 isolates of *E. lata* from a single vineyard and found 55 different RAPD haplotypes. Similarly, Péros *et al.* (1999) and Péros and Berger (1999) observed widespread genetic diversity within populations of *E. lata* when they were subjected to RAPD analysis. Given that *E. lata* is dispersed by ascospores, and that conidia are not believed to be capable of initiating infections (Carter, 1991), it is not surprising that significant variation between isolates of *E. lata* was observed here.

In summary, SCAR markers for use in a PCR-based assay have been developed which are specific towards Australian isolates of *E. lata*, and were also capable of amplifying DNA from isolates originating in Europe and the USA. Results of this and other studies indicated that the two isolates from which DNA could not be amplified using these SCAR primers were not *E. lata*, and may not belong to the genus *Eutypa*. That one of these isolates originated from grapevine and appeared identical to *E. lata* following growth on artificial medium highlights the need for the development of a rapid, reliable technique for the identification of *E. lata* in culture. The SCAR markers developed here provide a rapid and reliable means of confirming the identity of the pathogen in culture.

---

## **Chapter 4 Development of RFLP markers specific to *E. lata*.**

---

### **4.1 Introduction**

The polymerase chain reaction has been used to detect various pathogens of grapevine in wood, including *P. chlamydosporum* (Groenewald *et al.*, 2000; Ridgway *et al.*, 2002), *Agrobacterium vitis* (Eastwell *et al.*, 1995) and *E. lata* (Irelan *et al.*, 1999; Lecomte *et al.*, 2000). However, it is widely documented that compounds such as polyphenolics or polysaccharides in plants, may inhibit the polymerase chain reaction (Couch and Fritz, 1990; Lodhi *et al.*, 1994; Bahnweg *et al.*, 1998; Green *et al.*, 1999; Wolf *et al.*, 1999).

An alternative to PCR for the DNA-based detection of pathogens is the use of Southern blotting techniques which involve the transfer of DNA from an agarose gel to a nylon or nitrocellulose membrane (Southern, 1975) and the subsequent hybridisation of this transferred DNA to a probe specific to the pathogen of interest. Although this approach is not as sensitive as a PCR-based assay it has the advantage of being much less susceptible to inhibition by compounds present in wood and, hence, may provide a more robust and consistent means of detecting *E. lata* in infected wood. The efficacy of this technique has been demonstrated in slot blot hybridisation assays used to detect *Phomopsis viticola* in infected grapevine wood (Melanson *et al.*, 2002).

The aim of the work reported in this chapter was to develop an *E. lata* genomic DNA library to generate clones specific to the pathogen. These clones could be used as probes in Southern hybridisation experiments, such as slot blots, to detect the pathogen in infected wood without using PCR. In addition, genetic variation among Australian and overseas isolates of *E. lata* was assessed using random probes selected from the *E. lata* genomic DNA library.

### **4.2 Materials and Methods**

#### **4.2.1 Construction of genomic DNA library of *E. lata***

##### **4.2.1.1 Preparation of insert and vector DNA**

DNA from *E. lata* isolate M280 was inserted into the plasmid vector pBluescript using methods modified from Sambrook *et al.* (1989). DNA was extracted as outlined in



section 2.4 and further purified using a GeneClean II kit (Bio 101, USA) according to the manufacturer's instructions. DNA (5 µg) was digested overnight at 37°C with 20 units of *Pst* I enzyme (Roche Diagnostics, Germany), 0.1 vol of 10 x restriction buffer and sterile dd H<sub>2</sub>O to a final volume of 50 µl. Digested DNA was precipitated in 15 mM of sodium acetate (pH 5.2) and 2.5 vol of absolute ethanol for 1 h at -20°C. Following centrifugation for 15 min at 14,000 rpm the supernatant was discarded and the pellet washed twice with 100 µl of 70% ethanol. Digested DNA was re-suspended in sterile dd H<sub>2</sub>O to a final concentration of 100 ng/µl.

Vector DNA (2 µg) from the plasmid pBluescript was digested for 4 h at 37°C with *Pst* I enzyme as outlined above. The digest was precipitated in 15 mM sodium acetate (pH 5.2) and 2.5 vol of absolute ethanol for 1 h at -20°C. Following centrifugation and washing as outlined above, vector DNA was re-suspended in sterile dd H<sub>2</sub>O to a final concentration of 100 ng/µl. To prevent self-ligation of the vector, the 5' terminal phosphate group was removed using calf intestinal alkaline phosphatase (CIAP) as follows; digested vector DNA (1.6 µg) was incubated with 1 unit CIAP and 0.1 vol of 10 x phosphatase buffer at 37°C for 30 min, then incubated at 65°C for a further 10 min. An additional 5 units of CIAP were added and the mixture incubated for a further 30 min at 37°C. The reaction volume was adjusted to 50 µl with the addition of dd H<sub>2</sub>O and 2 µl of 0.5 M EDTA was added to stop the reaction. Vector DNA was extracted twice with 50 µl of phenol:chloroform:isoamyl alcohol (25:24:1) with centrifugation at 14,000 rpm for 10 min, then precipitated with 2 vol of absolute ethanol and 0.5 vol of 7.5 M ammonium acetate at -70°C for 30 min. Following centrifugation at 14,000 rpm for 10 min the supernatant was discarded, the pellet rinsed with 70% ethanol and DNA re-suspended in 20 µl sterile dd H<sub>2</sub>O.

#### **4.2.1.2 Ligation and transformation reactions**

A series of ligation reactions using insert:vector ratios of 3:1, 2:1 and 1:2 was prepared. Each ligation reaction consisted of 75 ng de-phosphorylated pBluescript vector, 0.1 vol of 10 x ligation buffer, 10 mM ATP, 0.25 units of T4 DNA ligase and the calculated amount of *E. lata* DNA. Reaction vol were adjusted to 20 µl using dd H<sub>2</sub>O. For each reaction, vector, insert and water were added to a 200 µl microcentrifuge tube, mixed by vortexing and incubated at 45°C for 5 min. Following chilling on ice for 5 min, ligation buffer, ATP and T4 ligase were added, the reactions mixed by pipetting and incubated at 4°C for 16 h. Also included were two ligation controls consisting of:

- 1) *Pst* 1-digested de-phosphorylated vector, ligation buffer and ATP, excluding *E. lata* DNA and T4 DNA ligase, to assess the number of background colonies resulting from the vector alone;
- 2) *Pst* 1-digested vector, ligation buffer, T4 DNA ligase and ATP, excluding *E. lata* DNA, to assess the efficiency of the CIAP treatment.

Following incubation at 4°C the ligation reaction mixtures were used to transform high efficiency competent cells of *E. coli* strain JM 109 (Promega Corporation, USA).

Transformations were carried out with 75 ng of pBluescript vector and an assumed average insert size of 4 kb, using methods modified from Sambrook *et al.* (1989). The amount of DNA required per transformation reaction was calculated as follows:

$$\frac{\text{ng of vector} \times \text{insert size (kb)}}{\text{vector size (kb)}} \times \text{insert:vector ratio} = \text{ng of insert required}$$

A transformation control, using 25 ng of super helical circular pUC19 DNA added directly to 100 µl competent cells, was included to monitor the efficiency of the competent cells.

Competent cells (100 µl) were added to a 2 µl aliquot of each ligation reaction. Reaction mixtures were gently mixed and placed on ice for 30 min then heat shocked for 2 min at 42°C in a water bath. Reactions were immediately returned to ice for 2 min then 400 µl of SOC medium (appendix A) was added and incubated at 37°C for 1 h with shaking at 180 rpm. A 100 µl aliquot of each transformation culture was transferred onto four duplicate LB/amp/IPTG/X-Gal plates (appendix A) for colour selection (see section 3.2.2). For the controls, two duplicate plates were used. Plates were incubated for 16-24 h at 37°C then screened for the presence of transformant colonies. White colonies, presumed to contain inserts, were transferred to fresh LB/amp/IPTG/X-Gal plates using a sterile toothpick.

#### **4.2.1.3 Analysis of recombinant colonies for specificity to *E. lata***

A total of 556 randomly selected, putative recombinant colonies was transferred onto replicate LB/amp/IPTG/X-Gal plates in a grid formation (Grunstein and Hogness, 1975; Sambrook *et al.*, 1989). A blue, non-recombinant colony was included in the last grid position. Following incubation overnight at 37°C, colonies were transferred to a 132 mm diameter, 0.45 µm positively charged nylon membrane (Amersham, UK) marked

with a grid pattern to accommodate 140 colonies. The membrane was then placed upon a fresh LBamp plate (150 mm diameter, Appendix A). Each colony was also transferred to a fresh LB/amp/IPTG/X-gal plate. Plates were incubated overnight at 37°C.

Colonies that formed on the nitrocellulose membranes were prepared for hybridisation using the Grunstein method (Sambrook *et al.*, 1989). Bacterial cells were lysed by washing membranes in 10% sodium dodecyl sulphate for 3 min. DNA was then denatured for 7 min in 0.5 M NaOH and 1.5 M NaCl, renatured twice for 5 min each with 1.5 M NaCl and 0.5 M Tris, pH 7.5 and washed for 5 min in 2 x SSC (Appendix A). DNA was fixed to the membrane using a Bio-Rad® GS Gene Linker™ UV Chamber at 150 mJ. Membranes were sealed between polyethylene sheets and stored at 4°C.

Membranes were screened to find clones specific to, and present in, all *E. lata* isolates. Specificity of clones was initially evaluated by hybridising separately with 50 ng of *Pst* 1-digested genomic DNA obtained from either grapevine, isolate 1739 (*Phellinus punctatus*) or *E. lata* isolate M280 using the techniques outlined in section 2.5. Radioactively-labelled membranes were exposed to X-ray film (X-Omat, Kodak, USA) at -70°C for up to 7 days.

Initial screenings of the colonies transferred using the Grunstein technique showed very low signal strength following labelling with *Pst* 1-digested DNA from *E. lata* isolate M280. For more sensitive screening of transformant bacteria, 100 clones were randomly selected and grown overnight in LBamp broth at 37°C and plasmid DNA was extracted using a Promega Wizard® Plus Minipreps DNA purification system according to the manufacturer's instructions. *Pst* 1 restriction digests were carried out on purified plasmid preparations to confirm the presence of inserts in putative transformants. Plasmid DNA was separated by electrophoresis on 1% TBE gels and DNA was transferred to nylon membranes by Southern transfer as outlined in section 2.5.1. Membranes were initially screened with digested grapevine DNA, and subsequently with DNA from *E. lata* isolate M280 using the technique outlined in section 2.5.3. The strength of each signal arising from hybridisation of *E. lata* DNA to each clone was rated as high, medium, low or no signal.

Selected clones which showed a medium or high signal when screened with *E. lata* DNA and no signal with grapevine DNA were selected for evaluation as potential *E. lata*-specific DNA probes. These clones were screened against genomic DNA from 17 *E. lata* isolates, 12 non-*E. lata* isolates and grapevine DNA. Genomic DNA (500 ng) was digested with *Pst* 1 and transferred to a nylon membrane by Southern transfer (see section 2.5.1).

Undigested plasmid DNA from the selected *E. lata*-specific clone, C68, was adjusted to 250 ng/ $\mu$ l and analysed by automated DNA sequencing (Flinders University of South Australia DNA Sequencing Core facility), in forward and reverse directions, using the universal primers M13F and M13R (Messing, 1983), with an Applied Biosystems ABI 373XL Automated Sequencer. DNA sequence editing was conducted using the program Chromas version 1.45 (Technelysium, Australia). Aligned sequence data were then imported into BioManager.com. The GenBank DNA and protein sequence database was searched for homology to other sequences using the BlastN and BlastX programs, respectively (Altschul *et al.*, 1997).

#### **4.2.1.4 Storage of recombinant colonies**

White bacterial colonies containing inserts of DNA from *E. lata* were transferred to 10 ml LBamp broth (Appendix A) and incubated overnight at 37°C with shaking at 180 rpm. Cultures were then stored at -70°C in 15% glycerol.

#### **4.2.2 Genetic variation within *E. lata***

Genetic variation among 38 isolates received as *E. lata* was assessed using six randomly selected clones which gave high or medium strength signals following hybridisation to DNA of *E. lata*. DNA (750 ng) was digested with either *Eco* R1 or *Pst* 1 and transferred to a nylon membrane as outlined in section 2.5.1. Clones were radioactively labelled as outlined in section 2.5.3 and used as probes to examine DNA polymorphisms among the 38 isolates.

##### **4.2.2.1 Data analysis**

Isolates used in Southern blot analysis were scored for the presence (1) or absence (0) of bands. Genetic similarities between all pairs of isolates following digestion with each enzyme were calculated using the algorithms of Nei and Li (1979) and Link *et al.* (1995), to form a similarity matrix, and data was analysed using the methods outlined in section 3.2.6.1.

## 4.3 Results

### 4.3.1 Analysis of *E. lata* genomic DNA library

The transformation reaction using an insert:vector ratio of 3:1 yielded 730 white colonies on the four replicate plates. Insert:vector ratios of 2:1 and 1:2 yielded 301 and 7 colonies, respectively. Hybridisation experiments revealed that two of the 556 colonies transferred using the Grunstein technique showed faint signals towards grapevine DNA digested with *Pst* 1 following X-ray exposure for 7 days at  $-70^{\circ}\text{C}$ . Similarly, two colonies showed a faint signal following hybridisation with *Pst* 1-digested DNA from isolate 1739 (*P. punctatus*). However, hybridisation reactions conducted using *Pst* 1-digested DNA from *E. lata* isolate M280 also revealed very low hybridisation of DNA. Only 13 colonies gave a medium-strength signal and approximately 50 colonies gave either a low or very low signal. On the basis of these results it was concluded that the Grunstein transfer method was not sensitive enough to allow for reliable detection and analysis of transformant colonies.

Consequently, plasmid DNA from 100 randomly selected, putative transformant colonies was digested with *Pst* 1. Agarose gel electrophoresis of the digested plasmids revealed that 19 contained multiple inserts and 11 contained no visible inserts. The remaining 70 clones each contained a single insert. Hybridisation experiments with radioactively labelled genomic DNA from *E. lata* isolate M280 digested with *Pst* 1 showed that only three of the 100 clones produced hybridisation signals which were considered high after X-ray exposure for 5-7 days at  $-70^{\circ}\text{C}$ . Of the remaining clones, 58 displayed a medium-strength signal, 23 a low strength-signal and 16 either a slight or no signal. An example of the screening of a membrane containing 18 clones is given in Figure 4.1.

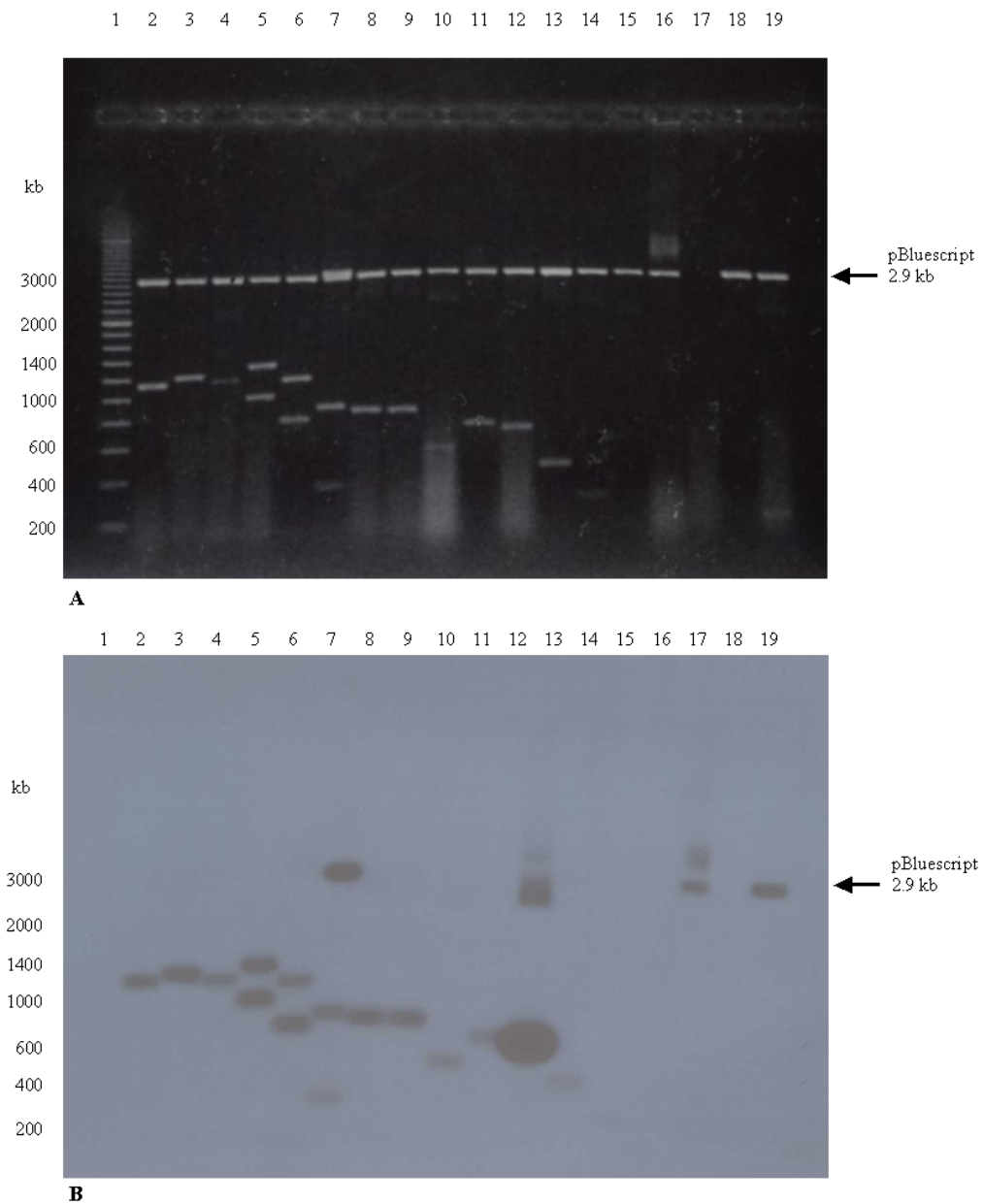
### 4.3.2 Analysis of recombinant colonies for specificity to *E. lata*

Of the 100 randomly selected clones, two with a high-strength signal (clones C68, lane 12 in Figure 4.1, and B40) and three with a medium-strength signal (clones A13, C35 F1 and C35 F2) were selected for screening against digested DNA from a range of *E. lata* and non-*E. lata* isolates as well as grapevine DNA. Clone C68 proved specific to *E. lata*, giving a strong signal when hybridised to DNA from all *E. lata* isolates, but not to any non-*E. lata* isolates or grapevine DNA after X-ray exposure for 3-10 days at  $-70^{\circ}\text{C}$  (Figure 4.2). Clone C35 F2 was also specific to *E. lata*, however, signals were

extremely faint following X-ray exposure for 10 days at  $-70^{\circ}\text{C}$  (data not shown). Clone B40 gave a strong signal when hybridised to DNA from all *E. lata* isolates and also to DNA from non-*E. lata* isolates C2a, C2c, 1735, W01, W07, EV01, EV02, EV03, 1739, 1740, 1750 and 1775, as well as grapevine DNA (data not shown). Clones A13 and C35 F1 gave a signal when hybridised to DNA from all *E. lata* isolates but also to non-*E. lata* isolates C2a, C2c, 1735, EV01, EV02 and EV03, but not to grapevine DNA (data not shown). Consequently, clone C68 was selected for use as an *E. lata*-specific DNA probe.

Sequence analysis of clone C68 revealed that the DNA fragment was 649 base pairs long. No significant homology to any known nucleotide or protein sequences was observed among sequences which are available in the GenBank database. Hybridisation of clone C68 to *Pst* I-digested DNA from 34 isolates of *E. lata* resolved a strong signal at approximately 650 bp in all isolates with the exception of isolate 83339 where a strong signal was evident at approximately 2,400 bp (data not shown). Fainter signals at approximately 3,000 bp and 750 bp were also present in some isolates. Hybridisation of clone C68 to the same 34 isolates following digestion with *Eco* RI resolved two DNA fragments in all isolates, one of approximately 2 kb and the other of either 700 or 800 bp, depending on the isolate (data not shown).

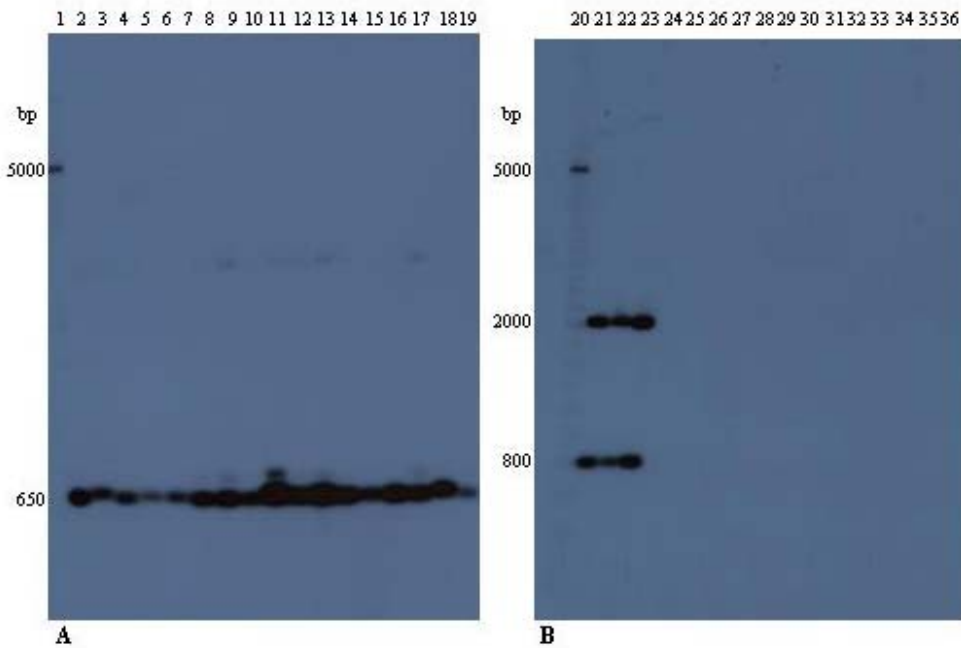
When these experiments were in progress, it was believed that isolates E178 and SS1#1, referred to in the previous chapter, were *E. lata*. However, hybridisation with clone C68 failed to detect either of these isolates (Figure 4.3). Consequently, the 100 randomly selected clones were also hybridised with DNA digested with *Pst* I from isolates E178 and SS1#1. Hybridisation with DNA from isolate E178 revealed six clones with a weak signal, two clones with a medium-strength signal and three clones with a high-strength signal following X-ray exposure for 3-10 days at  $-70^{\circ}\text{C}$ . An example of the screening of one such membrane using genomic DNA of isolate E178 as a probe is given in Figure 4.4. In this instance, two clones gave a strong signal (lanes 10 and 11), one a medium-strength signal (lane 7) and three a weak or very weak signal strength (lanes 5, 9, 14).



**Figure 4.1** Example of *E. lata* recombinant plasmid DNA digested with *Pst* 1. Lane 1, 200 bp DNA ladder; lanes 2-19 *E. lata* clones digested with *Pst* 1 (C71, A52, A53, C97, C66, C28, C89, C136, A57, C23, C68, C27, C16, C19, C93, A50, C40, A55).

**A** 1% TBE agarose gel electrophoresis of purified plasmid DNA.

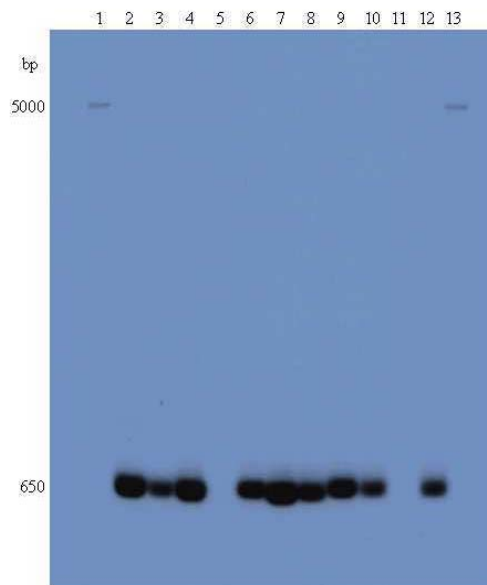
**B** Corresponding autoradiograph following hybridisation with *Pst* 1-digested DNA from *E. lata* isolate M280 and X-ray exposure for 7 days at  $-70^{\circ}\text{C}$ .



**Figure 4.2** Southern hybridisation of *E. lata*-specific probe C68 to digested genomic DNA from *E. lata*, grapevine and various grapevine-inhabiting fungi, following X-ray exposure for 3 days at  $-70^{\circ}\text{C}$ .

**A** *E. lata* DNA digested with *Pst* 1 restriction enzyme: Lane 1, 200 bp DNA ladder; lanes 2-19 DNA from *E. lata* isolates M280, M295, M302, N01, N04, N07, N08, AsW, Cab2, SS2, SS4, SS6, SS10, SS 357-3, Pear#1 SS12, A166, EVS.

**B** Lane 20, 200 bp DNA ladder; lanes 21-23 *Eco* R1-digested DNA from *E. lata* isolates M302, N04, SS6; lanes 24-35 *Pst* 1 digested DNA from non-*E. lata* isolates C2A, C2C, 1735, W01, W07, EV01, EV02, EV03, 1739, 1740, 1750, 1775; lane 36 *Pst* 1-digested DNA from grapevine.



**Figure 4.3** Southern hybridisation of *E. lata*-specific probe C68 to *Pst* 1-digested genomic DNA from *E. lata*. Lanes 1 and 13, 200 bp DNA ladder; lanes 2-12 DNA from *E. lata* isolates E1, E120, E125, E178, M266, M279, M280, M335, N04, SS1#1, SS6.





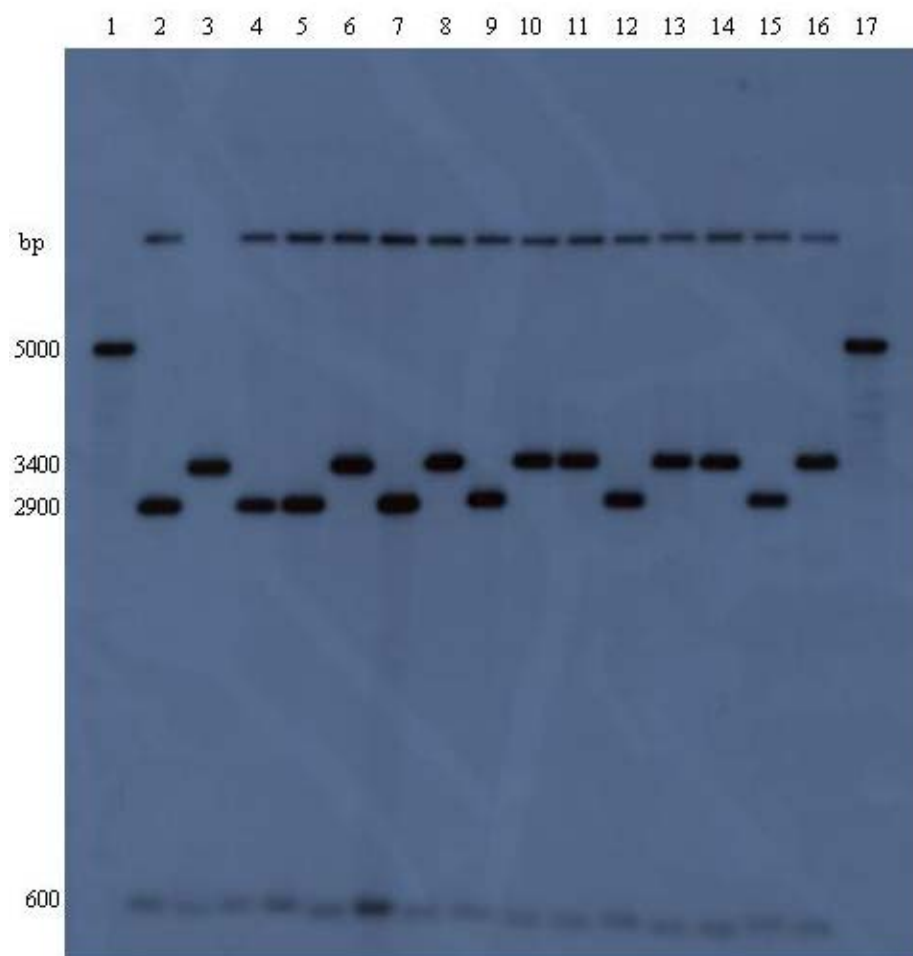
**Figure 4.4** Southern blot of *E. lata* recombinant plasmid DNA digested with *Pst* 1 and hybridised with *Pst* 1-digested DNA from isolate E178. Lanes 1 and 20, 200 bp DNA ladder; lanes 2-19, *E. lata* clones digested with *Pst* 1 (B3, B12, B25, B27, B28, B31, B33, B34, B35, B40, B41, B46, B58, B60, B69, B71, B74, B87) following X-ray exposure for 3 days at  $-70^{\circ}\text{C}$ .

Hybridisation of the same membranes with DNA from isolate SS1#1 revealed six clones with a weak signal and one clone with high signal (data not shown). Three of these clones gave a signal for both isolates, however, one of these was in such low copy number that it was barely visible after X-ray exposure for 9 days at  $-70^{\circ}\text{C}$ . The remaining clones, A13 and B40, gave medium and strong signals, respectively, to both isolates after X-ray exposure for 3-4 days at  $-70^{\circ}\text{C}$ . However, it was previously demonstrated that neither of these clones was specific to *E. lata* (section 4.3.1). Given these results and those obtained whilst developing SCAR markers specific to *E. lata* (see Chapter 3), it was concluded that these isolates were not *E. lata*, hence, no further attempts were made to obtain clones which detected these isolates.

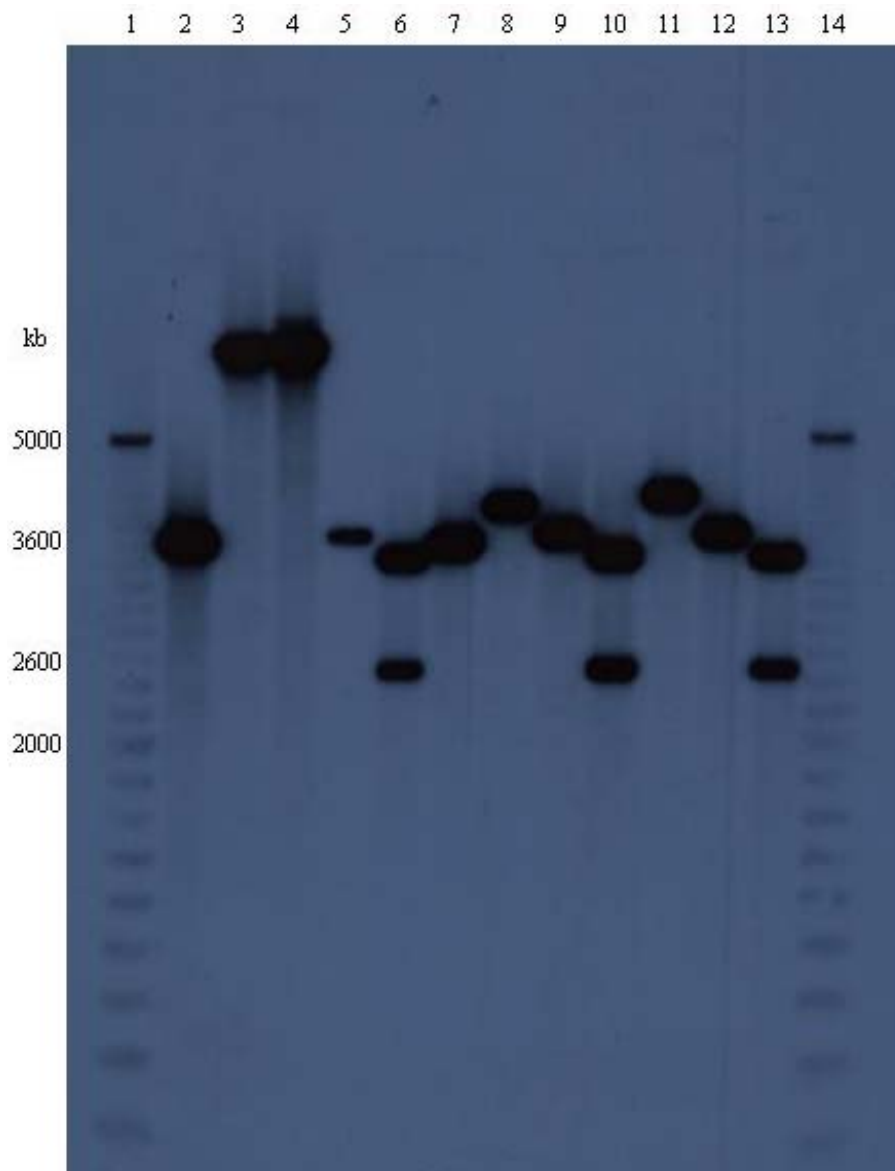
### 4.3.3 Genetic variation within *E. lata*

Southern analysis of DNA from 38 isolates received as *E. lata* digested with restriction enzyme *Eco* R1 and hybridised with six random clones revealed a high degree of polymorphism, with 35 unique phenotypes resolved. Isolates N04 and JB16 shared an identical phenotype, as did isolates SS1#1, SS1#3 and SS1#9. All clones revealed polymorphisms between isolates with a total of 43 different DNA fragments detected. Representative Southern blots containing DNA of *E. lata* digested with *Eco* R1 and labelled with either probe C14 or B40 are given in Figures 4.5 and 4.6. When conducting neighbour joining analysis, isolate E178, now believed to be a species other than *E. lata* (DeScenzo *et al.*, 1999; W.D. Gubler, *pers. com.*), was defined as the outgroup. The three isolates from New Zealand (SS1#1, SS1#3 and SS1#9) formed a

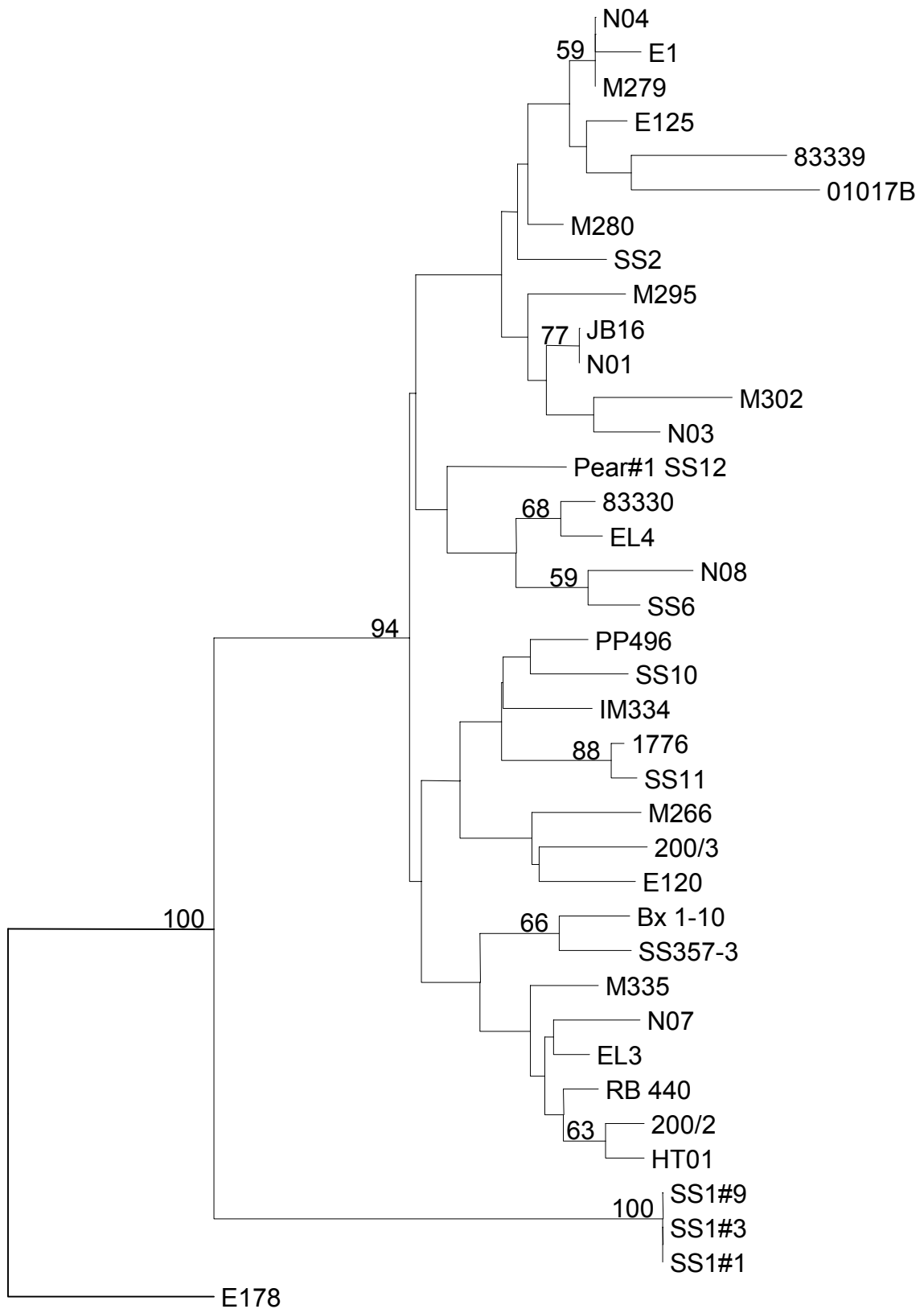
distinct group which was strongly supported by bootstrap analysis (Figure 4.7). The remaining isolates were placed in a single group which was strongly supported by a bootstrap value of 94%. Although isolates within this group were placed in two sub-groups, this was not strongly supported by bootstrap analysis. There was some variation in bootstrap values when neighbour joining trees were created from distance data calculated using the alternative algorithm of Link *et al.* (1995). However, all major groupings were the same as those obtained when distances were calculated using the algorithm of Nei and Li (1979) (data not shown).



**Figure 4.5** Example of Southern blot of DNA from 15 isolates of *E. lata* digested with restriction enzyme *Eco* R1 and hybridised with probe C14. Lanes 1 and 17, 200 bp DNA ladder; lanes 2-16 DNA from *E. lata* isolates N01, N03, JB16, 200/3, SS357-3, M295, M302, Pear#1 SS12, SS10, SS1#1, 01017B, 1776, 83339, Bx1-10, PP496.



**Figure 4.6** Example of Southern blot of DNA from 12 isolates of *E. lata* digested with restriction enzyme *Eco* R1 and labelled with probe B40. Lanes 1 and 14, 200 bp DNA ladder; lanes 2-13 DNA from *E. lata* isolates RB 440, SS1#3, SS1#9, EL3, EL4, HT01, IM334, N07, N08, SS2, 200/2, 83330.

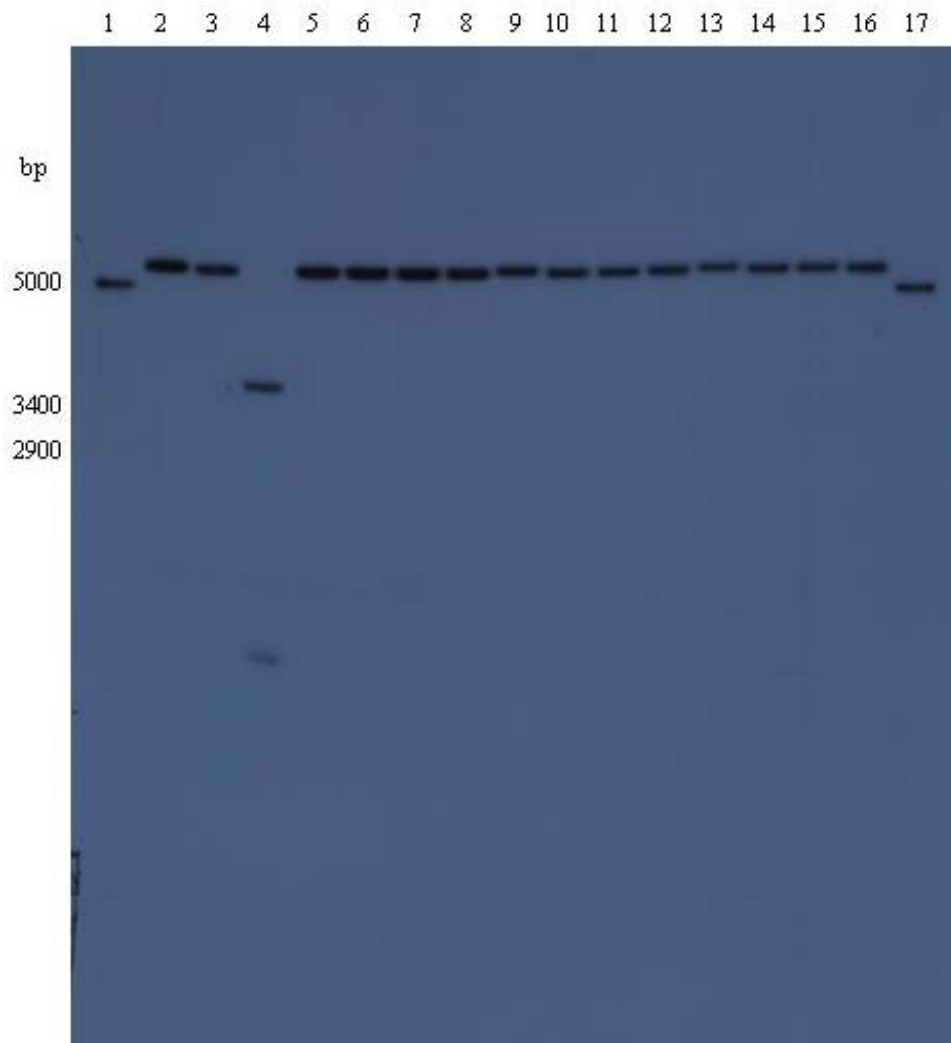


**Figure 4.7** Neighbour joining tree generated using TREECON (Van de Peer and De Wachter, 1994), showing grouping of 38 isolates following digestion with restriction enzyme *Eco* R1 and hybridisation with six probes. Isolate E178 was specified as the outgroup. Distances were calculated using the algorithm of Nei and Li (1979). Bootstrap values greater than 50% are given.

Analysis of DNA from the same 38 isolates following digestion with *Pst* 1 and hybridisation with the same six probes revealed fewer polymorphisms than that following digestion with *Eco* R1, with 26 polymorphic bands being detected. Seventeen phenotypes were resolved among the 38 isolates. As for digestion with *Eco* R1, isolates SS1#1, SS1#3 and SS1#9 shared identical phenotypes. Fifteen phenotypes were resolved among the remaining 34 isolates. Representative Southern blots containing DNA of *E. lata* digested with *Pst* 1 and labelled with probe C14 or B40 are given in Figures 4.8 and 4.9.

Neighbour joining analysis placed isolates SS1#1, SS1#3 and SS1#9 apart from all other isolates, with strong support by bootstrap analysis (Figure 4.10). Among the remaining 34 isolates, isolate 83339 was distinct from all other isolates. This distinction was supported by a bootstrap value of 79%. Several other isolates were grouped together with significant support by bootstrap analysis, although no major groupings of isolates were evident (Figure 4.10). No significant differences in tree topology were observed when neighbour joining trees were constructed using the algorithm of Link *et al.* (1995) (data not shown).

Analysis of combined data generated following hybridisation of all six probes to genomic DNA digested with both *Eco* R1 and *Pst* 1 separated isolates SS1#1, SS1#3 and SS1#9 from all other isolates. This was supported by a bootstrap value of 99% (Figure 4.11). The majority of other groupings were not strongly supported by bootstrap analysis, with only six groups having bootstrap values greater than 50% (Figure 4.11).



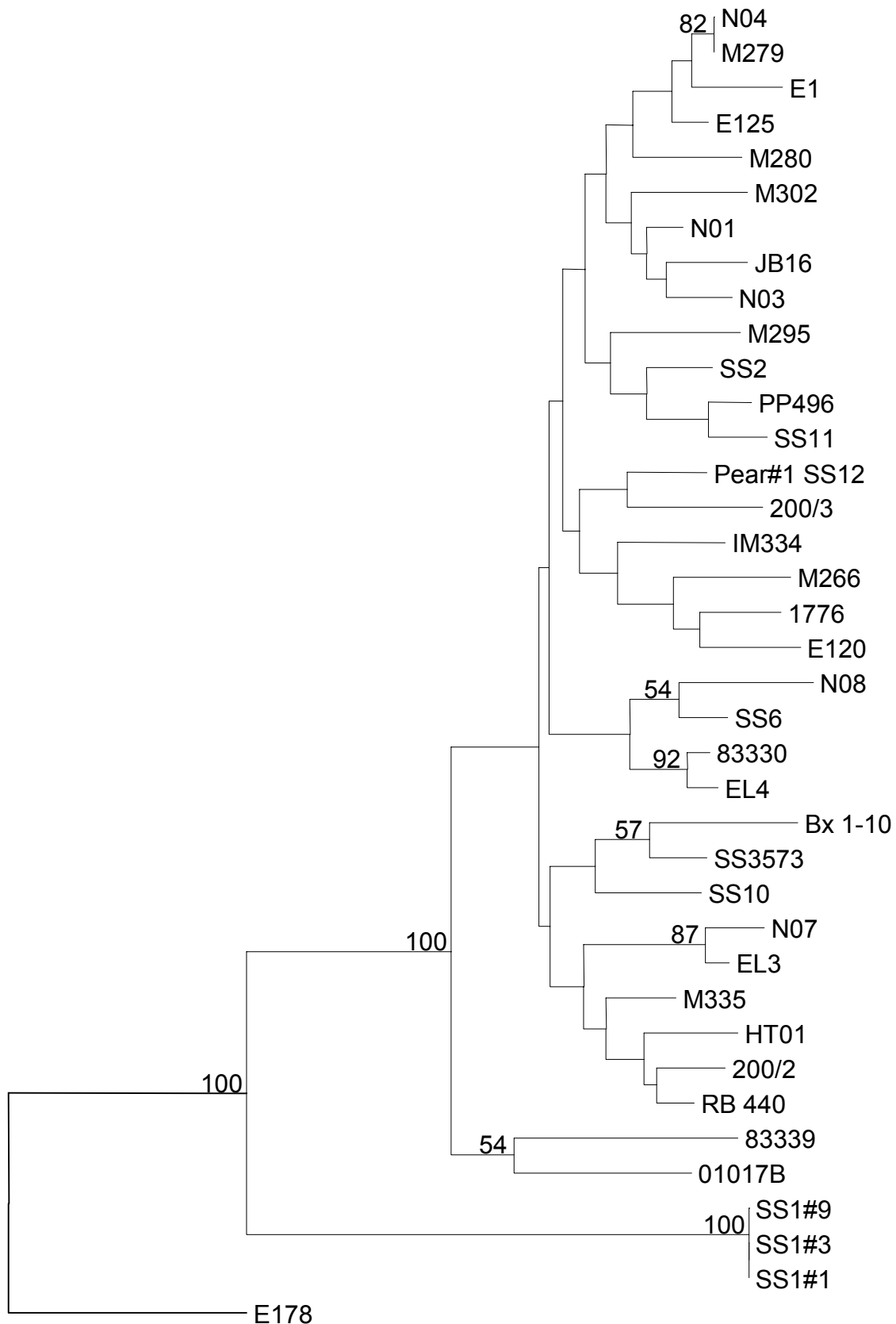
**Figure 4.8** Example of Southern blot of DNA from 15 isolates of *E. lata* digested with restriction enzyme *Pst* I and labelled with probe C14. Lanes 1 and 17, 200 bp DNA ladder; lanes 2-16 DNA from *E. lata* isolates N01, N03, JB16, 200/3, SS357-3, M295, M302, Pear#1 SS12, SS10, SS1#1, 01017B, 1776, 83339, Bx1-10, PP496.



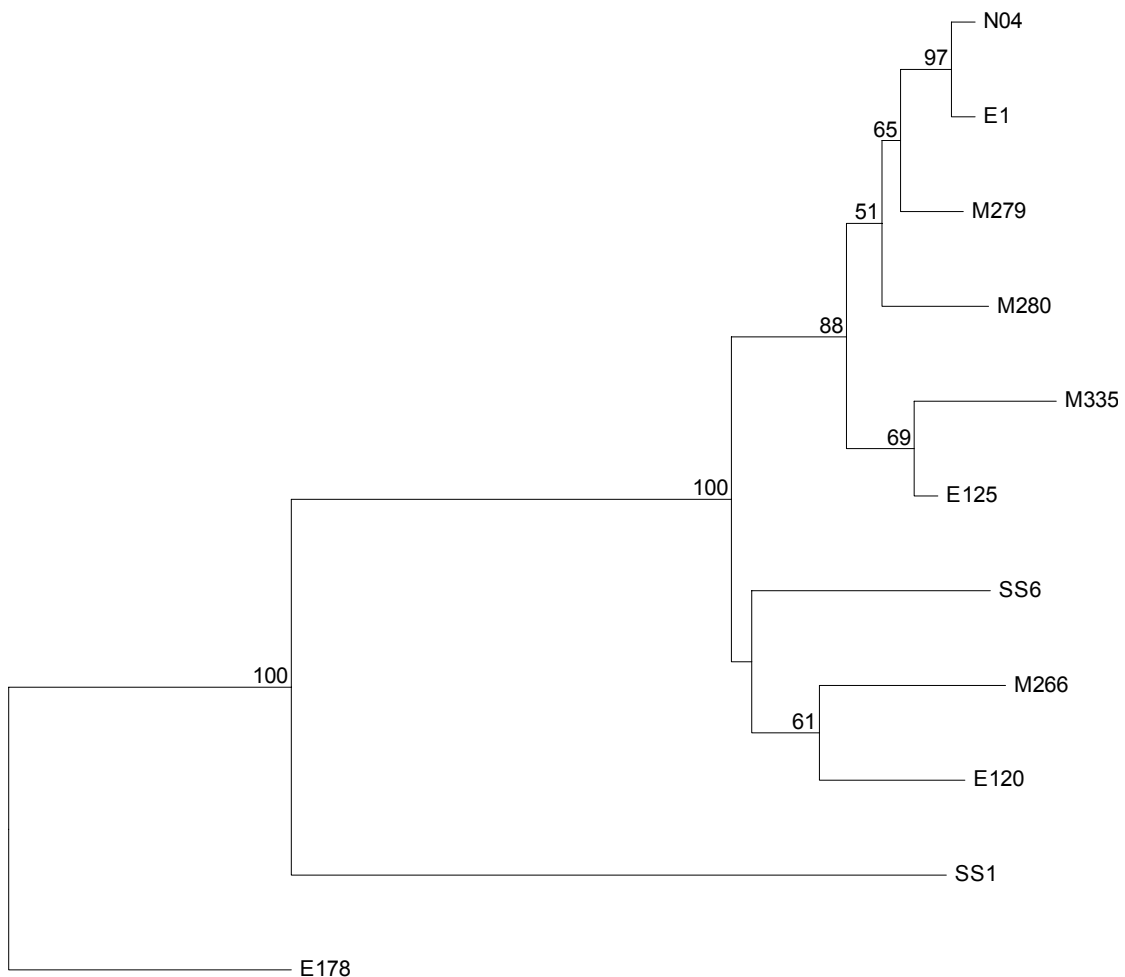
**Figure 4.9** Example of Southern blot of DNA from 13 isolates of *E. lata* digested with restriction enzyme *Pst* I and labelled with probe B40. Lanes 1 and 14, 200 bp DNA ladder; lanes 2-14 DNA from *E. lata* isolates RB 440, SS1#3 SS1#9, EL3, EL4, HT01, IM334, N07, N08, SS2, SS11, 200/2, 83330.







To compare groupings obtained by analysis of RFLP and RAPD data, separate trees were constructed using RFLP data for the 11 isolates which had been analysed with RAPD primers (see Chapter 3). Analysis of combined data generated following digestion of DNA from the 11 isolates with *Eco* R1 and *Pst* 1 placed isolate SS1#1 apart from all other isolates (Figure 4.12). The remaining nine isolates were placed in two distinct groups. Grouped together were isolates M335, E125, N04, M279, M280 and E1 in the first group, and isolates SS6, M266 and E120 in the second (Figure 4.12). Although the grouping of the first set of isolates was strongly supported by a bootstrap value of 88%, the second group was not strongly supported by bootstrap analysis.



**Figure 4.12** Neighbour joining tree generated using TREECON (Van de Peer and De Wachter, 1994), showing RFLP data from 11 isolates following digestion with restriction enzymes *Eco* R1 and *Pst* 1 and labelling with six probes. Isolate E178 was specified as the outgroup. Distances were calculated using the algorithm of Nei and Li (1979). Bootstrap values greater than 50% are given.

## 4.4 Discussion

Of the 100 random probes hybridised to genomic DNA from *E. lata* isolate M280, the majority did not produce strong hybridisation signals after X-ray exposure for 5-7 days at  $-70^{\circ}\text{C}$ . This indicates that these probes were low copy number and did not contain repetitive DNA. Three of the probes selected for further analysis were not specific to DNA from *E. lata* and hybridised to DNA from a range of other grapevine-inhabiting fungi. However, the size of the restriction fragments observed for the non-*E. lata* isolates differed to those observed for isolates of *E. lata*, indicating that these sequences did not share 100% homology with those of *E. lata*. One of the *E. lata*-specific probes showed only a faint signal after X-ray exposure for 10 days at  $-70^{\circ}\text{C}$  and, hence, would not have been well suited for use as a diagnostic probe. However, probe C68 was specific to *E. lata* and gave a strong signal following hybridisation to genomic DNA from *E. lata* after X-ray exposure for 3-5 days at  $-70^{\circ}\text{C}$  and, hence, was selected for use as an *E. lata*-specific probe. The use of this probe for detecting the pathogen in infected grapevine wood and cane is reported in Chapter 5.

Several probes hybridised to DNA from either isolate E178, isolate SS1#1, or to both isolates. However, the majority of probes did not hybridise to DNA from these isolates. Of the three probes which did hybridise to DNA from both isolates, one gave such a weak signal that it would not have been suitable for use as a diagnostic probe and the remaining two probes were not specific to *E. lata*. The fact that only six of the 100 probes analysed here hybridised to DNA of these two isolates provides further evidence that they are genetically distinct from *E. lata*.

RFLP analysis of 38 isolates revealed significant genetic variation between isolates. A total of 69 polymorphic markers was detected following digestion of isolates with either *Eco* R1 or *Pst* 1 and hybridisation with six random probes. Analysis of the combined data revealed that each isolate had a unique phenotype. Significant differences were observed following digestion of *E. lata* DNA with either *Pst* 1 or *Eco* R1. It is known that restriction enzymes have differing abilities to detect polymorphisms (Whitkus *et al.*, 1994). *Eco* R1 is known to reveal high levels of polymorphism (Whitkus *et al.*, 1994) and here 43 polymorphic DNA fragments were detected following digestion of genomic DNA with this enzyme and hybridisation to six random probes. In contrast, 26 polymorphic DNA fragments were revealed following hybridisation with *Pst* 1-digested

DNA. Consequently, phylogenetic trees representing the relationships of *E. lata* isolates towards one another were considerably different when using data derived from each enzyme. The tree constructed using both sets of data more closely resembled that obtained for *Eco* R1-digested DNA rather than *Pst* 1-digested DNA. This is, in part, due to the fact that following analysis with *Eco* R1 43 polymorphisms were apparent, whereas only 26 polymorphisms were revealed following digestion of DNA with *Pst* 1.

There was no apparent correlation between geographic origin or host species of isolates and RFLP profiles. For example, of the isolates which were grouped together with bootstrap values of greater than 50% following neighbour joining analysis of combined data after digestion of genomic DNA with *Eco* R1 and *Pst* 1 (Figure 4.11), isolates EL4 and 83330 originated from South Africa and Australia and were obtained from grapevine and peach, respectively. Isolates EL3 and N07, also from South Africa and Australia, were both obtained from grapevine, isolates SS11 and PP496, from Australia and France, were both obtained from grapevine, and isolates M279, N04 and E125, the first two from Australia and the third from California, were obtained from apricot (M279) and grapevine (N04 and E125). Similarly, neighbour joining analysis following digestion of DNA with *Pst* 1 alone, did not show any significant correlations with either host or geographic origin of isolates, although only 15 phenotypes were resolved among the 34 isolates of *E. lata*. For example, isolates 01017B and Bx 1-10, both obtained from grapevine, which were paired with 93% support by bootstrap analysis, originated in Australia and France, respectively. In some instances, isolates of similar origin were placed in the same group, for example isolates SS11, SS6 and SS2, all from grapevine in South Australia, were grouped together along with isolate PP496, from grapevine in Spain. However, this grouping was only weakly supported by a bootstrap value of 50%.

These results are similar to those obtained by Péros *et al.* (1996), who conducted RAPD analysis of 18 isolates of *E. lata* obtained from grapevine in ten geographic locations. No correlation was observed between geographic origin and RAPD banding patterns (Peros *et al.*, 1996). DeScenzo *et al.* (1999) subjected 115 isolates of *E. lata* to AFLP and rDNA ITS sequence analysis. These isolates were obtained from a range of host species and geographic locations, however there was no correlation between host species or geographic origin and AFLP or rDNA ITS data. Isolate E178, included in the analyses of DeScenzo *et al.* (1999), was shown by these authors to be distinct from the majority of other isolates on the basis of AFLP and rDNA analysis. However, seven

other isolates, obtained from either grapevine, Valley oak or madrone, were placed in the same group as this isolate (DeScenzo *et al.*, 1999). It was on the basis of this research that DeScenzo *et al.* (1999) suggested that isolate E178 should perhaps be reclassified as *E. armeniaca*. Although no attempt was made to identify this isolate to species level in the current study, the results of both the current research and that carried out by DeScenzo *et al.* (1999) indicate that on the basis of molecular evidence this isolate should not be classified as *E. lata*.

The wide range of phenotypes present among isolates of *E. lata* studied here is in agreement with findings reported by Péros and co-workers (Péros *et al.*, 1996; Péros and Berger, 1999; Péros *et al.*, 1999) following RAPD analysis of *E. lata*. For example, Péros *et al.* (1999) detected 56 different phenotypes among 56 isolates of *E. lata* collected from 41 localities in the Languedoc-Roussillon region of France. Considerable variation was also observed by DeScenzo *et al.* (1999) following AFLP and rDNA ITS sequence analysis. These high levels of diversity are not surprising given that *E. lata* is primarily dispersed by ascospores and that perithecia are believed to result from outcrossing (Péros and Berger, 1999; Cortesi and Milgroom, 2001).

In all RFLP analyses, the three isolates obtained from New Zealand were grouped apart from all other isolates. This grouping, which was invariably supported by a high bootstrap value, provides further evidence that isolate SS1#1 and the other two isolates from New Zealand are not *E. lata*.

Isolates E178 and SS1#1 were separated from each other and all other isolates on the basis of both RAPD and RFLP data. However, no correlations were apparent between RAPD and RFLP profiles of the remaining nine isolates of *E. lata*. Given the small sample size and the fact that RFLP analysis did not resolve any groupings among the isolates of *E. lata* analysed here, it is not entirely surprising that no such correlations were apparent.

None of the clones detected here were of high copy number and, as reported in Chapter 5, membranes needed to be exposed to X-ray film for up to 8 days in order to detect the pathogen in infected wood. For the purposes of a commercial diagnostic test it would be preferable to use a probe with a higher copy number in order to enable the more rapid detection of the pathogen. However, it was not the aim of this study to develop

DNA probes for commercial application, but rather for use as a research tool, hence, the prolonged exposure times were not of particular concern. When conducting RFLP analysis, it is preferable to use probes containing fewer repetitive sequences which will hybridise to between one and five loci and allow for more accurate resolution and scoring of DNA profiles (Whitkus *et al.*, 1994; Ito *et al.*, 1998). Hence, the probes used in RFLP analysis in the current study were capable of generating profiles which were clear and easy to interpret.

In summary, DNA probes specific to *E. lata* were identified that gave a strong signal towards genomic DNA after 2-3 days X-ray exposure at  $-70^{\circ}\text{C}$  following hybridisation to approximately 500 ng of digested DNA from *E. lata*. RFLP analysis revealed considerable genetic variation among the Australian isolates of *E. lata* analysed here, as has been observed by researchers in other countries.

---

## Chapter 5 Detection of *E. lata* in infected grapevine wood

---

### 5.1 Introduction

Chemical and biological control agents are not capable of eradicating *E. lata* once it has become established in a grapevine. The recommended method of eradication is to remove all infected wood, characterised by a wedge-shaped staining of vascular tissue, as well as 10-20 cm of apparently healthy wood below the canker (Anon, 1997). However, little is known regarding the rate of spread of *E. lata* in grapevine tissue, and it is not known whether this procedure is sufficient to remove all mycelium of *E. lata* from infected vines, or whether removal of less than 10–20 cm of healthy wood would be effective. Hence, in order to eradicate the disease, and to evaluate potential control measures, there is a need for information to be gathered on both the rate of spread and the distribution of the pathogen in infected vines.

The major aim of the work reported in this chapter was to assess the ability of the PCR-based SCAR markers and RFLP-based Southern probes, developed in this study (see Chapters 3 and 4), to detect *E. lata* in grapevine wood known to be infected with the pathogen. Polyphenolic compounds present in grapevine wood may inhibit PCR, following the co-purification of these compounds with DNA and their subsequent interactions with nucleic acid (Lodhi *et al.*, 1994; Eastwell *et al.*, 1995; Kim *et al.*, 1997; Zhang *et al.*, 1998; Green *et al.*, 1999; Wolf *et al.*, 1999). Hence, a variety of DNA extraction protocols and detection methods were tested in order to develop an assay suitable for use in epidemiological studies and as a tool to assess potential control agents against the disease.

### 5.2 Methods

#### 5.2.1 PCR-based detection of *E. lata*

Infected 1-year-old cane segments (cv. Cabernet Sauvignon) were provided by Dr Mette Creaser, who had inoculated the material with suspensions of *E. lata* ascospores 12 months previously (Creaser and Wicks, 2002) and by Ms Sharmini John, who had inoculated the material with mycelium of *E. lata* isolate M280 12 months previously (John, 2003). Wood from naturally infected grapevine trunks (cv. Cabernet Sauvignon) was obtained from Wirra Wirra Vineyards in McLaren Vale, South Australia. Unless

otherwise stated, mycelium of *E. lata* was isolated from all samples by plating wood-chips onto PDA as described in section 2.1.

### **5.2.1.1 PCR amplification conditions**

Amplification by PCR was carried out in a total volume of 25  $\mu$ l, containing 6-30 ng of DNA. Each reaction mixture contained 0.1 vol of 10 x thermophilic buffer (500 mM KCl, 100 mM Tris-HCl (pH 9.0), 1% Triton<sup>®</sup>X-100), 2 mM MgCl<sub>2</sub>, 200 mM each of dATP, dCTP, dGTP, dTTP (Roche Diagnostics, Germany), 0.2  $\mu$ M of primer and 1 unit of *Taq* DNA polymerase (Promega, USA). Negative controls, using sterile dd H<sub>2</sub>O instead of DNA, were included in each experiment. Amplification was carried out in 0.6 ml thin-walled PCR tubes, using a Corbett Research PC-960 thermocycler. Unless otherwise stated, SCAR primer pair 634L21/12U20 was used in all reactions. Use of this primer pair is expected to result in a PCR product of 640 bp following amplification of *E. lata* DNA.

Amplification of DNA was achieved by an initial denaturation step of 2 min at 94°C, followed by 37 cycles of 30 s at 94°C, 30 s at 65°C and 1 min at 72°C, with a final extension of 10 min at 72°C. Amplification products were visualised following staining of agarose gels with ethidium bromide (see section 3.2.1).

### **5.2.1.2 DNA extraction protocols**

Various DNA extraction protocols, detailed below, were used to isolate DNA of a quality suitable for use in PCR amplifications using DNA derived from grapevine wood and cane samples known to be infected with *E. lata*. Included were the protocols of Lecomte *et al.* (2000) and Irelan *et al.* (1999), which have been used to detect *E. lata* in infected wood with minimum sample preparation.

#### **Rapid extraction protocol of Lecomte *et al.* (2000)**

The following protocol (Lecomte *et al.*, 2000) was used to isolate DNA directly from infected wood samples. Three thin wood chips, approximately 5 x 5 x 0.2 mm, were excised from the margin of discoloured and healthy wood on two grapevine canes provided by Dr Creaser. The three wood chips from each sample were placed in a 1.5 ml microcentrifuge tube containing 50  $\mu$ l of sterile dd H<sub>2</sub>O and incubated at 95°C for 15 min. The resulting suspensions were immediately placed on ice, and 5  $\mu$ l of a 1:10 and 1:100 dilution of the suspension were subjected to PCR amplification. For each sample, four replicates of each dilution were subjected to PCR.



The same protocol was used to isolate DNA from three samples of mature grapevine wood from which *E. lata* mycelium was recovered, however, in this instance, SCAR primer pair SCA 10A and SCA 10B (Lecomte *et al.*, 2000) was used in the PCR. A 1:10 and 1:100 dilution of each suspension was subjected to PCR. Reactions were repeated following the seeding of each DNA extract with 10 ng of *E. lata* genomic DNA from isolate M820, in order to determine whether polyphenolic compounds were inhibiting the reaction. A further replicate, using aliquots of the same samples seeded with *E. lata* DNA, with the addition of 1% PVP-10 (polyvinylpyrrolidone, MW 10,000) to the reaction mixture, was included. PVP has been shown to alleviate the inhibition of PCR caused by polyphenolic compounds (Koonjul *et al.*, 1999). Because preliminary results indicated that the inclusion of PVP had the potential to enhance the amplification of *E. lata* DNA, a further experiment was conducted, in which PVP at 1, 1.5, 2, 2.5 or 3% was included in the reaction mixture. Aliquots of the three DNA extracts seeded with *E. lata* genomic DNA were used in this experiment.

#### **Rapid extraction protocol of Irelan *et al.* (1999)**

The proprietary method for DNA isolation direct from grapevine wood developed at E. & J. Gallo Winery was used to amplify *E. lata* DNA from eight 1-year-old cane samples inoculated with mycelium of *E. lata* isolate M280. Because this protocol was obtained under an intellectual property agreement, details may not be given here. Amplification reactions were conducted using primer pair 634L21/12U20 and a 1:100 dilution of each of the eight DNA extracts. Replicate reactions were conducted using 1% PVP-10 in the reaction mixture. Mixtures amended with PVP were amplified using both a 1:100 and 1:10 dilution of the original DNA extract, as recommended by researchers at E. & J. Gallo Winery.

#### **SEAPS extraction protocol**

Total DNA was extracted from 12 infected trunk samples using the SEAPS protocol as modified by Melanson *et al.* (2002). Grapevine wood (85 mg) was ground in liquid nitrogen and suspended in 10 vol of pre-heated (65°C) SEAPS buffer (Appendix A). Following 20 min incubation at 65°C, an equal volume of chloroform:*iso*-amyl alcohol (24:1) was added, and the suspension was mixed on a rotating disc for 10 min. Samples were centrifuged at 14,000 rpm for 20 min, the aqueous phase was retained, and RNase A added to a final concentration of 0.1 mg/ml. The solution was incubated at 37°C for 15 min, then extracted with an equal volume of chloroform:*iso*-amyl alcohol. The supernatant was transferred to a fresh microcentrifuge tube, and DNA precipitated by

the addition of 0.67 vol of ice-cold isopropanol for a minimum of 1h at -20°C. DNA was pelleted by centrifugation at 14,000 rpm for 10 min, and pellets were washed in 1 ml of 70% ice-cold ethanol. Samples were centrifuged at 14,000 rpm for 10 min, and ethanol was removed by aspiration. DNA pellets were re-suspended in 50 µl of TE buffer (Appendix A).

DNA obtained using this protocol was assessed in PCR using the universal R1 primer (Weining and Langridge, 1991). This primer was used instead of *E. lata*-specific primers because it would amplify DNA from both grapevine and *E. lata* and, hence, would provide amplification products even if no *E. lata* DNA was present in the sample. Genomic DNA extracted from micropropagated Cabernet Sauvignon grapevine plantlets using a DNeasy plant DNA extraction kit (Qiagen Inc., USA) was included as a positive control in the reaction.

#### **CTAB-based extraction protocol**

DNA was extracted from both a 1-year-old cane sample inoculated with *E. lata* ascospores, and a glasshouse-grown grapevine cutting inoculated with mycelium of *E. lata* isolate M280, using the protocol of Wolf *et al.* (1999). Grapevine tissue (500 mg) was ground in liquid nitrogen with 100 mg PVP-10, then transferred to a 15 ml centrifuge tube. CTAB extraction buffer (5 ml, appendix A) was added, and samples incubated at 60°C, with occasional mixing, for 30 min. Samples were centrifuged at 6,000 rpm for 15 min, then the supernatant was removed and mixed with 0.5 vol chloroform:*iso*-amyl alcohol (24:1) on a rotating disc for 5 min. Suspensions were centrifuged at 6,000 rpm for 15 min, the supernatant removed, and again centrifuged with an equal volume of chloroform:*iso*-amyl alcohol. The aqueous phase was transferred to a fresh tube, and 0.5 volumes of NaCl were added and mixed well. DNA was precipitated following the addition of two volumes of ice-cold ethanol and incubation at -20°C for 3 h. Samples were centrifuged for 3 min at 3,000 rpm, then 3 min at 5,000 rpm. The pellet was washed in ice-cold 76% ethanol and, following centrifugation and the removal of ethanol by aspiration, DNA was re-suspended in 100 µl TE buffer.

Both DNA extracts were subjected to PCR using SCAR primer pair 634L21/12U20, with 6, 12, 18 or 24 ng of template DNA. Two replicates of each DNA concentration were used. To determine whether the reaction was being inhibited by polyphenolic

compounds, 24 ng of template DNA from both samples was seeded with 10 ng of genomic DNA from *E. lata* isolate M280 prior to PCR amplification.

Initial experiments showed a faint band in reactions conducted using 12 ng of template DNA extracted from the cane inoculated with mycelium of *E. lata*, however, control reactions conducted using genomic DNA from *E. lata* isolate M280 resulted in an intense band. This indicated that compounds present in the DNA extract may have been inhibiting the reaction. To test this, a trial was set up to analyse the effect of various compounds which have been shown to enhance the amplification and specificity of PCR. Initially, replicate reactions, using 12 ng of template DNA from both DNA extracts were set up with PVP-10 at 0.5, 1, 1.5, 2, 2.5 or 3% in each reaction. Following the successful amplification of *E. lata* DNA using DNA extracted from cane inoculated with mycelium, this reaction was repeated, using both DNA extracts, following the addition of 2% (w/v) of either PVP-10, bovine serum albumin (BSA), polyethylene glycol (PEG), formamide, dimethyl sulphoxide (DMSO), dimethylformamide (DMF), or a mixture of formamide: BSA (2%: 1%) to the reaction mixture. These compounds have been shown to enhance the efficiency of PCR (Pomp and Medrano, 1991; Koonjul *et al.*, 1999; Chakrabarti and Schutt, 2001).

#### **Qiagen DNeasy kit (Qiagen Inc., USA)**

Two samples of grapevine DNA which had been extracted from 18-month-old grapevine cane using a DNeasy plant DNA extraction kit were provided by Dr Belinda Rawnsley. The canes were infected with *Phomopsis viticola*, and the DNA had been used in Southern hybridisation experiments to detect *P. viticola* using probes specific to that pathogen. The PCR competency of this DNA was initially assessed using the R1 primer, with 5, 10, 15 or 20 ng of DNA in each reaction.

Aliquots of each DNA sample (20 ng) were also seeded with 10 ng of genomic DNA from *E. lata* isolate M280, for subsequent PCR-based amplification using SCAR primer pair 634L21/12U20. These reactions were replicated with the inclusion of 2% PVP in the reaction mixture. Four replicates of each sample seeded with *E. lata* DNA were prepared.

#### **Modified DNeasy extraction protocol**

DNA was extracted from six grapevine cane samples which had been inoculated with *E. lata* ascospores, using the protocol of Green *et al.* (1999), which utilises the DNeasy kit

(Qiagen, USA). Samples (200 mg) were ground in liquid nitrogen with 2 ml CTAB extraction buffer (Appendix A). A 500 µl volume of the resulting suspension was transferred to a 1.5 ml eppendorf tube, and RNase A was added to a final concentration of 0.1 mg/ml. Samples were incubated at 65°C for 30 min with occasional mixing. Next, 162 µl of Qiagen AP2 buffer was added and the solution placed on ice for 5 min. The solution was decanted on to a Qias shredder column, centrifuged at 14,000 rpm for 5 min, and extractions were completed according to the manufacturer's instructions. Because *E. lata* was recovered from only one of the five canes, PCR using SCAR primer pair 634L21/12U20 was conducted with and without the addition of 10 ng of *E. lata* DNA. PVP-10 (2%) was included in all reaction mixtures.

#### **Bio-101 soil DNA extraction kit**

DNA was extracted from five grapevine canes which had been inoculated with ascospores of *E. lata*, using the Bio-101 fast DNA spin kit for soil (Bio-101, USA) according to the manufacturer's instructions. PVP-10 (2%) was included in all reaction mixtures, which were amplified using SCAR primer pair 634L21/12U20. DNA from an additional 10 canes, also inoculated with ascospores of *E. lata*, was subsequently extracted using this technique.

#### **Silica-based extraction protocol**

A silica-based extraction protocol (Rott and Jelkmann, 2001), previously used to extract RNA from cherry leaves, known to have a high phenolic and polysaccharide content, was used to extract DNA from six grapevine trunks naturally infected with *E. lata*. Additional extractions, from the same 10 canes which were extracted using the Bio-101 soil DNA extraction kit, were also conducted. Samples (300 mg) were ground in liquid nitrogen along with 4 ml grinding buffer (Appendix A). A 500 µl aliquot of the suspension was transferred to a 1.5 ml microcentrifuge tube to which was added 100 µl of 10% *N*-lauryl sarkosine and 5 µl β-mercaptoethanol. The mixture was incubated at 70°C for 10 min, placed on ice for 5 min, and centrifuged at 13,000 rpm for 10 min. The aqueous phase (300 µl) was transferred to a fresh tube, and 150 µl of ethanol, 300 µl NaI (6 M) and 25 µl re-suspended silica (Appendix A) were added. Samples were placed on a rotating disc for 10 min, then centrifuged at 6,000 rpm for 1 min. The pellet was re-suspended in 500 µl wash buffer (Appendix A) and centrifuged at 6,000 rpm for 1 min. The wash was repeated, and the pellet re-suspended in 150 µl dd H<sub>2</sub>O. PVP-10

(2%) was included in all PCR amplifications, which were conducted using SCAR primer pair 634L21/12U20.

## 5.2.2 Southern hybridisation-based detection of *E. lata*

Infected grapevine material, in the form of 1-year-old canes inoculated either with mycelium or ascospores of *E. lata*, or naturally infected trunk material obtained from Wirra Wirra Vineyards, was used for the detection of *E. lata* using clone C68 (see Chapter 4) and the slot blot technique. DNA was extracted using the SEAPS protocol of Melanson *et al.* (2002, see section 5.2.1.2), which has been used to extract DNA from grapevine cane infected with *P. viticola* for use in slot blot assays.

### 5.2.2.1 Slot blot transfer

Samples were adjusted to a total of 200 ng DNA in 200  $\mu$ l dd H<sub>2</sub>O, then 200  $\mu$ l of 0.8 M NaOH, 20 mM EDTA denaturation solution (for a final concentration of 0.4 M NaOH, 10 mM EDTA) was added, and samples denatured by incubation at 100°C for 10 min. DNA was transferred to a positively charged nylon membrane (Amersham, UK) with a Bio-Dot<sup>®</sup> SF apparatus (Bio-Rad, USA), according to the manufacturer's instructions. After rinsing briefly with 2 x SSC (Appendix A), DNA was fixed to the membrane using a Bio-Rad<sup>®</sup> GS Gene Linker UV Chamber at 150 mJ. Membranes were sealed between polyethylene sheets and stored at 4°C until required. DNA was hybridised with clone C68 as described in section 2.4.3.

The suitability of the slot blot technique was first assessed using DNA extracted from 12 grapevine canes grown in the glasshouse, 10 of which had been inoculated with *E. lata* mycelial plugs. *E. lata* mycelium was isolated from two of these samples using the technique described in section 2.1. Included as controls in this trial were genomic DNA from grapevine trunk pathogen isolates 1739, 1740, 1750, 1765 and 1775 (see Table 2.1), as well as DNA from an uninfected micropropagated grapevine plantlet. Genomic DNA from *E. lata* isolate M280 (1 to 50 ng) was also included.

Additional slot blots were prepared using 19 DNA samples extracted from naturally infected 30-year-old Cabernet Sauvignon vines. Eleven of these DNA samples were isolated from the margin of discoloured and healthy wood in individual vines from which *E. lata* mycelium had been recovered. The remaining eight DNA samples were isolated from a cross-section of a single diseased cordon, the first sample from the centre of the canker, and the remaining seven from asymptomatic wood at locations

distributed evenly around the edge of the cross-section. *E. lata* mycelium was isolated from the margin of the canker of this diseased cordon.

A further 147 DNA extractions were carried out using 147 1-year-old canes which had been inoculated with *E. lata* ascospores in the field, and then treated with either the fungicide Fungaflor™ (42 canes) or a water control (44 canes). The remaining 61 canes had been wounded but not inoculated with *E. lata*.

## 5.3 Results

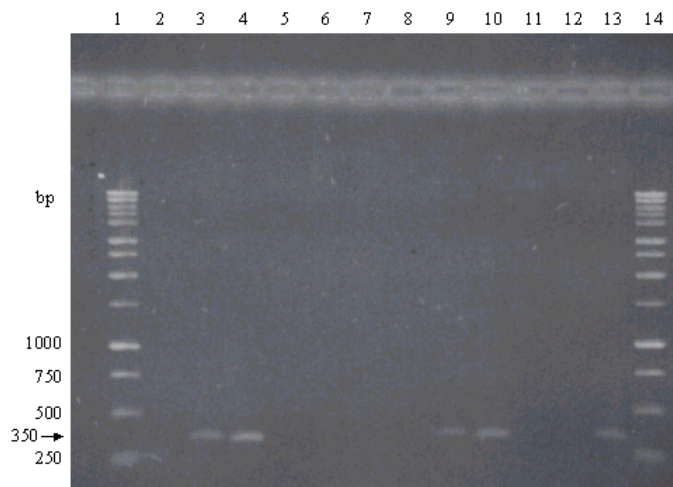
### 5.3.1 Rapid extraction protocol of Lecomte *et al.* (2000)

PCR amplification, using DNA extracted from infected canes and SCAR primer pair 634L21/12U20, produced no visible PCR products (data not shown), although the positive control gave a band of the expected size (640 bp). Similarly, no PCR products were visible when using DNA extracts from mature grapevine wood, amplified using SCAR primer pair SCA 10A and SCA 10B, although a band of the expected size (350 bp) was present in the positive control (data not shown).

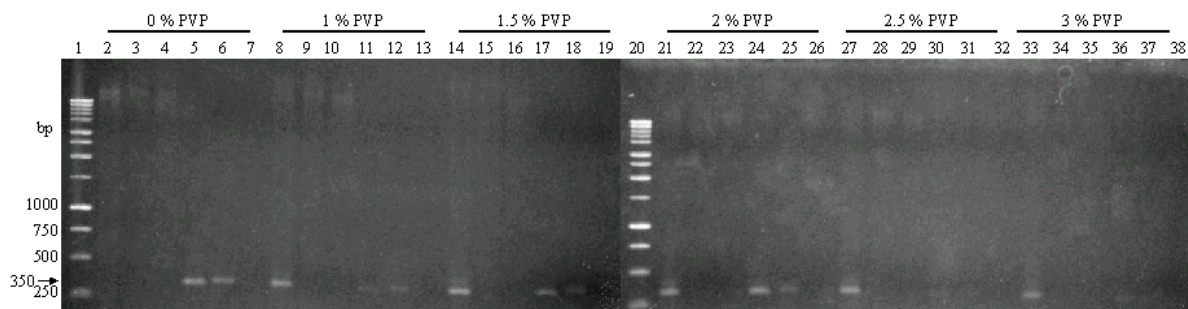
PCR amplification conducted using DNA extracts from mature grapevine wood which were subsequently seeded with *E. lata* genomic DNA, and SCAR primer pair SCA 10A and SCA 10B, also did not give any visible products (Figure 5.1, lanes 5-7). It was, therefore, concluded that the reaction had been inhibited, probably by polyphenolic compounds. Hence, a series of reactions was prepared using the three DNA extracts from mature grapevine wood, seeded with *E. lata* DNA, with 1% PVP-10 in the reaction mixture. DNA from one extract gave an amplification product of the expected size (350 bp, Figure 5.1, lane 13) following the inclusion of PVP in the reaction mixture, however, DNA from the remaining two extracts was not amplified. Positive controls, using genomic DNA from *E. lata* isolates N04 and M280, gave PCR products of the expected size in each case.

Because of the enhanced amplification in the presence of PVP, aliquots of the original DNA extracts seeded with *E. lata* DNA were subjected to PCR using PVP at 0.5 to 3%. However, although DNA from one extract gave an amplification product of the expected size with all concentrations of PVP (Figure 5.2, lanes 8, 14, 21, 27, 33), the remaining extracts did not result in visible bands in the gel. Positive controls, using genomic DNA from *E. lata* isolates N04 and M280, gave PCR products of the expected

size, however, with the exception of reactions containing 0 and 2% PVP, these bands were extremely faint (Figure 5.2).



**Figure 5.1** Amplification of DNA extracts obtained from mature grapevine wood, using SCAR primer pair SCA 10A and SCA 10B, and the rapid extraction protocol of Lecomte *et al.* (2000). Extracts from wood were seeded with genomic DNA from *E. lata* isolate M280. Lanes 1 and 14, 1 kb DNA ladder; lanes 2 and 8, dd H<sub>2</sub>O; lanes 3 and 9, genomic DNA from isolate N04; lanes 4 and 10, genomic DNA from isolate M280; lanes 5-7, DNA extract from wood amended with *E. lata* DNA (no PVP in the reaction); lanes 11-13, DNA extract from wood amended with *E. lata* DNA (1% PVP included in the reaction).

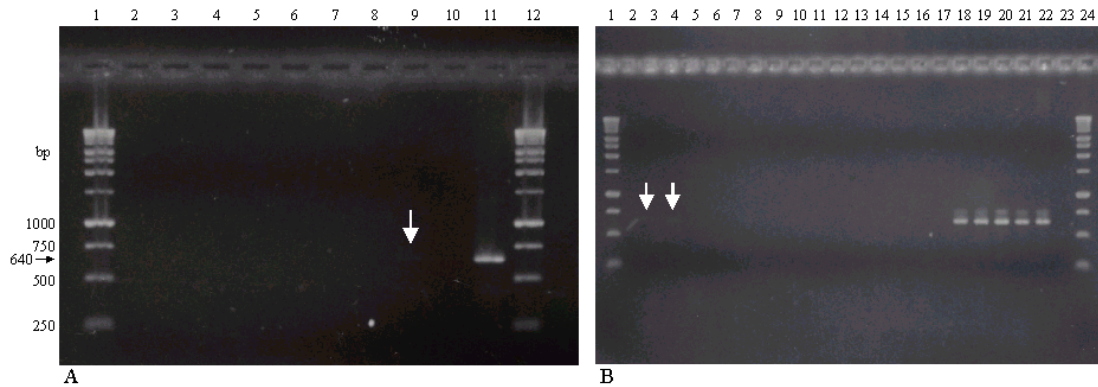


**Figure 5.2** Amplification of *E. lata* DNA extracted from infected canes, using primer pair SCA 10A and SCA 10B and the rapid extraction protocol of Lecomte *et al.* (2000), with the inclusion of PVP in the reaction mixture. Wood extracts were seeded with 10 ng genomic DNA from *E. lata* isolate M280. Lanes 1 and 20, 200 bp DNA ladder; lanes 2-4, 8-10, 14-16, 21-23, 27-29, 33-35, wood samples; lanes 5, 11, 17, 24, 30 and 36, genomic DNA from isolate N04; lanes 6, 12, 18, 25, 31 and 37, genomic DNA from isolate M280; lanes 7, 13, 19, 26, 32 and 38, dd H<sub>2</sub>O.

### 5.3.2 Rapid extraction protocol of Irelan *et al.* (1999)

In one DNA extract amplified without the addition of PVP, a very faint band of the expected size (640 bp) was visible under UV light, however, this could not be visualised in the Polaroid image of the gel (Figure 5.3A, lane 9). Similarly, two of eight DNA extracts gave faint amplification products when PVP was included in the reaction, although these bands could not be visualised in the Polaroid image (Figure 5.3B, lanes 3 and 4). Reactions conducted using a more concentrated sample (a 1:10 dilution of the original extract, rather than a 1:100 dilution) failed to give any amplification products in

the presence of PVP (Figure 5.3B, lanes 10-17). Bands of the expected size were in the Polaroid image of the gel (Figure 5.3A, lane 9). Similarly, two of eight DNA extracts gave faint amplification products when PVP was included in the reaction, although these bands could not be visualised in the Polaroid image (Figure 5.3B, lanes 3 amplified in positive control samples (Figure 5.3A, lane 11 and Figure 5.3B, lanes 18-22).



**Figure 5.3** Amplification of DNA extracts from infected canes, using SCAR primer pair 634L21/12U20 and the rapid extraction protocol of Ireland *et al.* (1999). Arrows indicate a faint PCR product of the expected size (640 bp), which could be visualised under UV light.

**A** 1:100 dilution of cane extracts; lanes 1 and 12, 1 kb DNA ladder; lanes 2-9, DNA from infected cane; lane 10, dd H<sub>2</sub>O; lane 11, genomic DNA from isolate M280.

**B** Amplification of the same DNA extracts, with 1% PVP in the reaction mixture. Lanes 1 and 24, 1 kb DNA ladder; lanes 2-9, 1:100 dilution of DNA from infected wood; lanes 10-17, 1:10 dilution of DNA from infected wood; lanes 18-22, genomic DNA from isolates M280, M302, N04, SS6 and 1776; lane 23, dd H<sub>2</sub>O.

### 5.3.3 SEAPS extraction protocol

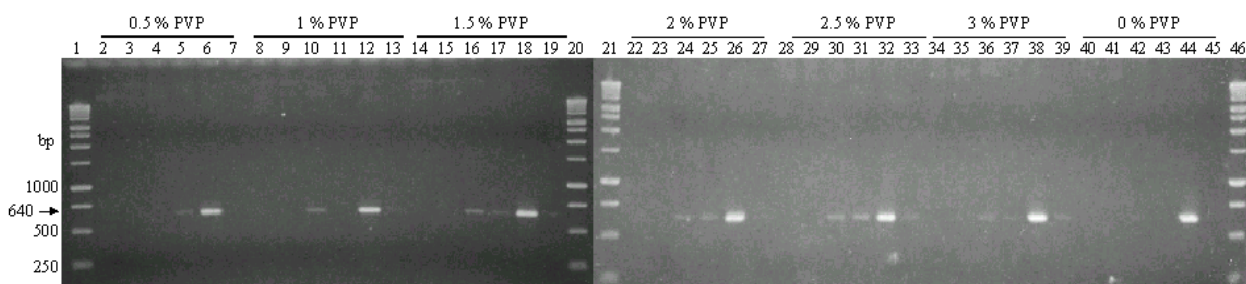
DNA isolated using the SEAPS extraction protocol of Melanson *et al.* (2002) failed to give a product following PCR using the R1 primer. However, DNA fragments were present in the control grapevine DNA sample, isolated from a micropropagated grapevine plantlet using the DNeasy extraction kit (data not shown).

### 5.3.4 CTAB-based extraction protocol

No intense bands were present following initial PCR using 6 to 24 ng of DNA, however, faint bands of the expected size (640 bp) could be seen under UV light in products from both reactions containing 12 ng of DNA extracted from the cane inoculated with mycelium of isolate M280, and the product from one reaction using 6 ng of DNA extracted from the same cane. These bands were not visible in Polaroid images (data not shown). Seeding of samples with *E. lata* genomic DNA resulted in the generation of faint amplification products in either one or both replicates of reactions containing DNA extracted from cane inoculated with mycelium, although not in DNA



extracted from cane inoculated with *E. lata* ascospores (data not shown). Inclusion of PVP in reaction mixtures, conducted using 12 ng of template DNA, resulted in faint amplification products of 640 bp in both replicates using DNA extracted from cane inoculated with mycelium in the presence of PVP at 1.5, 2, 2.5 and 3% (Figure 5.4, lanes 16, 17, 24, 25, 30, 31, 36, 37). DNA extracted from the cane that had been inoculated with ascospores of *E. lata* was not amplified (Figure 5.4). None of the other additives included in PCR reactions (see section 5.2.1.2, CTAB extraction protocol) facilitated amplification of DNA (data not shown). It should be noted that faint PCR products are visible in two of the negative control reactions in figure 5.4 (lanes 33 and 39). These are presumably a result of the inadvertent contamination of the control reactions with DNA of *E. lata*, however, PCR products were not observed in any other negative controls.



**Figure 5.4** PCR amplification of 12 ng of DNA extracted from inoculated grapevine cane using the protocol of Wolf *et al.* (1999), with the inclusion of PVP in the reaction. Lanes 1, 20, 21, 46, 200 bp DNA ladder; lanes 2, 3, 8, 9, 14, 15, 22, 23, 28, 29, 34, 35, 40, 41, DNA extracted from canes inoculated with *E. lata* ascospores; lanes 4, 5, 10, 11, 16, 17, 24, 25, 30, 31, 36, 37, 42, 43, DNA from canes inoculated with mycelium of *E. lata*; lanes 6, 12, 18, 26, 32, 38, 44, genomic DNA from isolate M280; lanes 7, 13, 19, 27, 33, 39, 45, dd H<sub>2</sub>O

### 5.3.5 Qiagen DNeasy kit

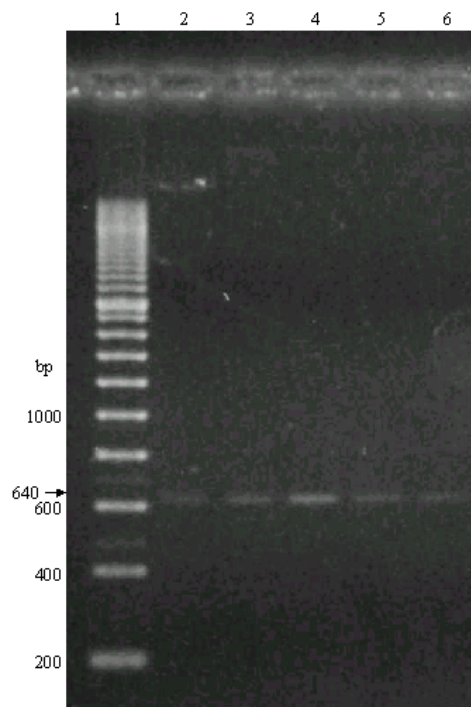
Initial reactions using DNA extracted using the DNeasy kit and the R1 primer failed to produce any amplification products (data not shown). Reactions conducted using SCAR primer pair 634L21/12U20 following the addition of *E. lata* genomic DNA to each sample also failed to produce amplification products. Similarly, no amplification products were present following the inclusion of PVP in the reaction mixture (data not shown).

### 5.3.6 Modified DNeasy extraction protocol

No PCR products were detected following amplification of DNA isolated from grapevine canes using the protocol of Green *et al.* (1999). However, following seeding of DNA extracts with genomic DNA from *E. lata* isolate M280, one sample showed a faint amplification product of the expected size (640 bp, data not shown).

### 5.3.7 Bio-101 soil DNA extraction kit

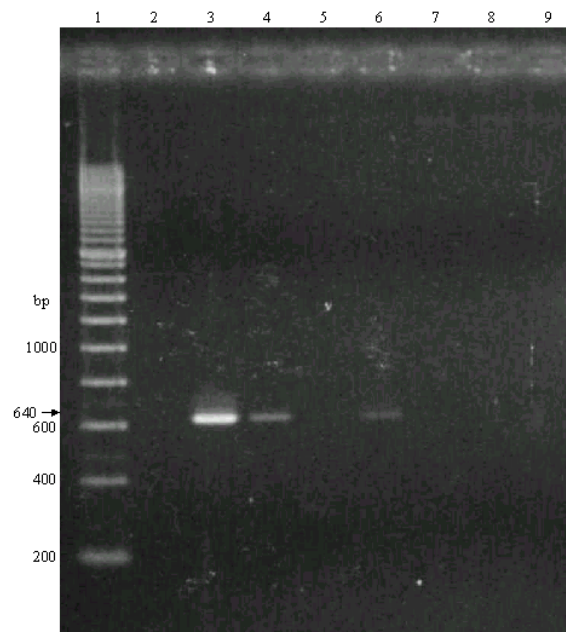
PCR products of the expected size (640 bp) were amplified from DNA extracted from the initial five grapevine canes following isolation using the Bio-101 extraction kit and amplification with SCAR primer pair 634L21/12U20 (Figure 5.5). Extraction of DNA from an additional 10 grapevine canes also resulted in amplification products of the expected size in each case (data not shown).



**Figure 5.5** Amplification of *E. lata* DNA isolated from five infected grapevine canes using the Bio-101 soil DNA extraction kit. Lane 1, 200 bp DNA ladder; lanes 2-6, DNA extracts. Negative and positive controls from this reaction are shown in lanes 2 and 3 of Figure 5.6, respectively.

### 5.3.8 Silica-based extraction protocol

Amplification of DNA from six grapevine trunk samples, extracted using the protocol of Rott and Jelkmann (2001), yielded DNA fragments of the expected size in two reactions (lanes 4 and 6, Figure 5.6). PCR amplification of DNA isolated from an additional 10 grapevine canes, from which replicate extractions were conducted using the Bio-101 soil DNA extraction kit, resulted in amplification products in five out of ten DNA extracts (data not shown).



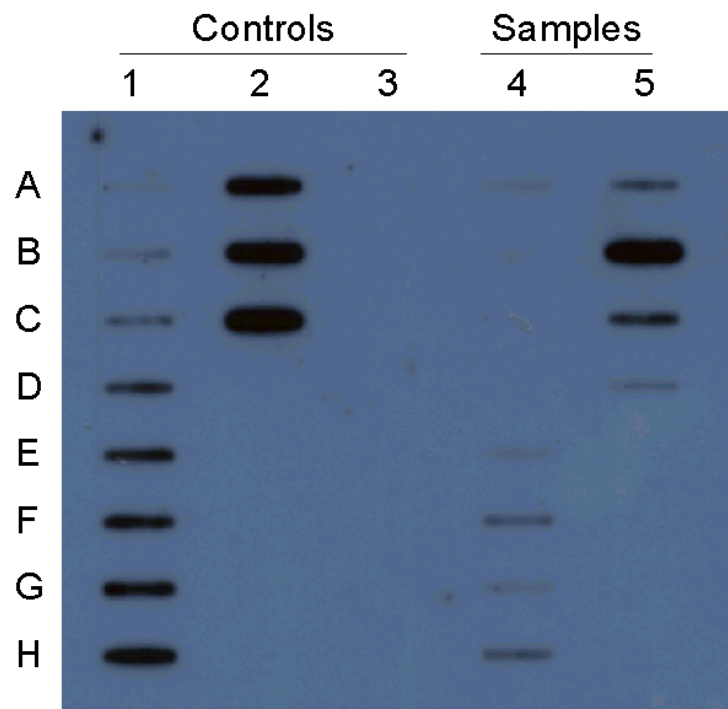
**Figure 5.6** Amplification of DNA isolated from six infected grapevine canes using the protocol of Rott and Jelkmann (2001) and SCAR primers 634L21/12U20. Lane 1, 200 bp DNA ladder; lane 2, dd H<sub>2</sub>O; lane 3, genomic DNA from *E. lata* isolate M280; lanes 4-9, DNA extracts from wood.

### 5.3.9 Southern hybridisation-based detection of *E. lata*

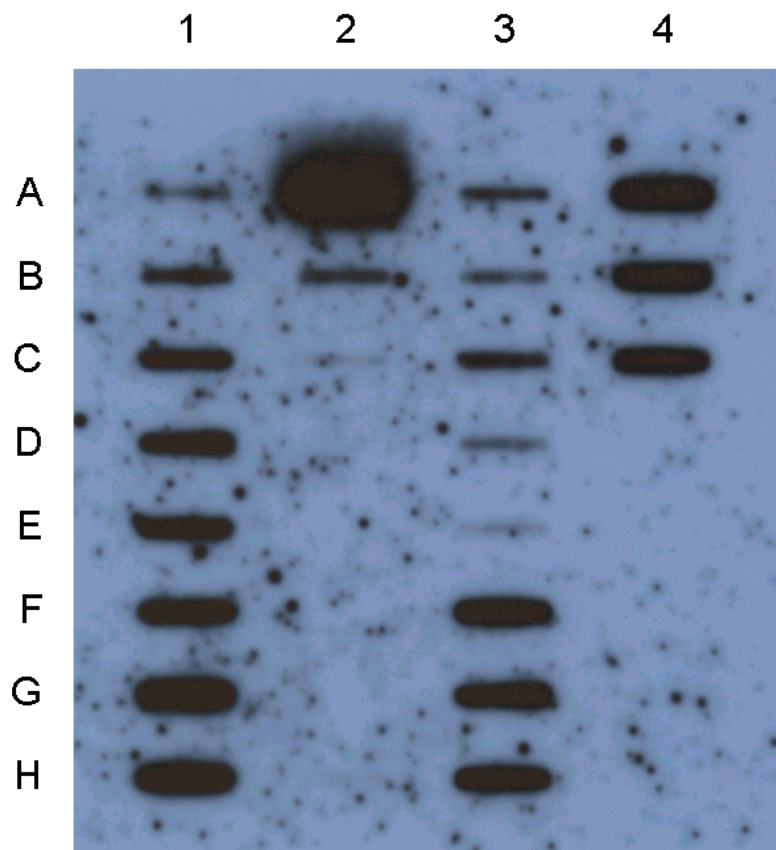
Initial slot blot assays, using DNA extracted from glasshouse-grown canes inoculated with mycelium of *E. lata*, detected *E. lata* DNA in nine of 10 extracts, following X-ray exposure for 8 days at -70°C (Figure 5.7). There was considerable variation in signal strength between DNA extracts, indicating that different amounts of DNA from *E. lata* were present in each cane. For example, slots 4A, 4E and 4G showed a very weak signal, corresponding to that of approximately 1 ng of *E. lata* genomic DNA (slot 1A), whereas slot 5B had a strong signal, corresponding to that of 40-50 ng of genomic DNA (slots 2B and 2C). No signal was detected in either of the un-inoculated controls, for DNA from tissue culture grapevines, or for DNA from other fungal species.

The slot blot prepared using DNA extracted from naturally infected grapevine trunks showed a signal in all 11 samples from which mycelium was recovered (Figure 5.8, slots 3A-4C). Again, there was considerable variation in the strength of signals obtained from different DNA extracts. DNA of *E. lata* was also detected in one sample taken from dead wood at the centre of a canker, and in two of seven samples taken from asymptomatic wood around the canker of the same cordon (Figure 5.8, slots 2A-2C). The sample taken from the dead wood at the centre of the canker (slot 2A) had an extremely strong signal, whereas the remaining two positive samples taken from asymptomatic wood (slots 2B and 2C) had a much weaker signal.

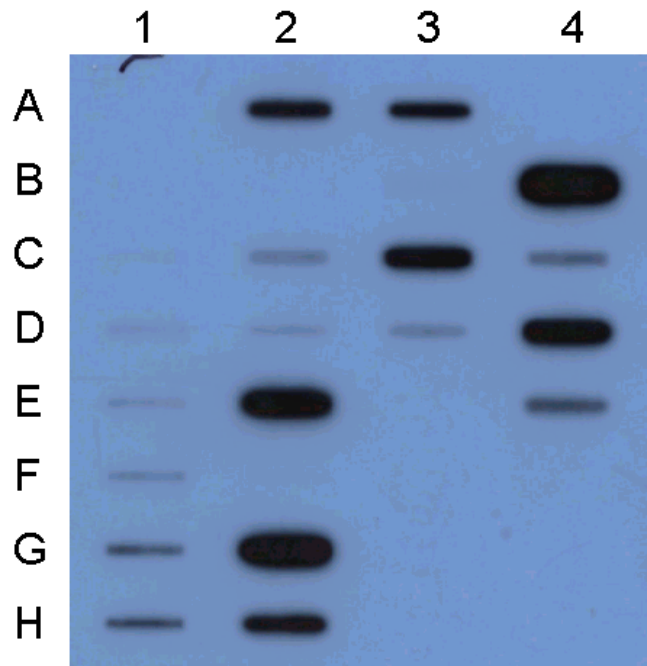
Analysis of DNA extracted from 1-year-old canes inoculated with *E. lata* ascospores in the field resulted in the detection of *E. lata* DNA in 50% of DNA samples isolated from canes treated with water following inoculation and in 43% of DNA samples isolated from canes treated with Fungaflor. Examples of slot blots are presented in Figures 5.9 and 5.10. Dr Creaser isolated *E. lata* from 23% of inoculated canes treated with water, and 16% of canes treated with Fungaflor. However, DNA of *E. lata* was detected in extracts from 66% of the un-inoculated canes, whereas Dr Creaser isolated *E. lata* from only 5% of these canes. DNA was extracted from 61 un-inoculated grapevine canes. These samples were transferred to two different membranes, the first containing DNA extracted from 40 canes, and the second containing DNA from 23 canes. DNA of *E. lata* was detected in 38 of 40 extracts (95%) on the first membrane, and in three of 21 (14%) on the second membrane.



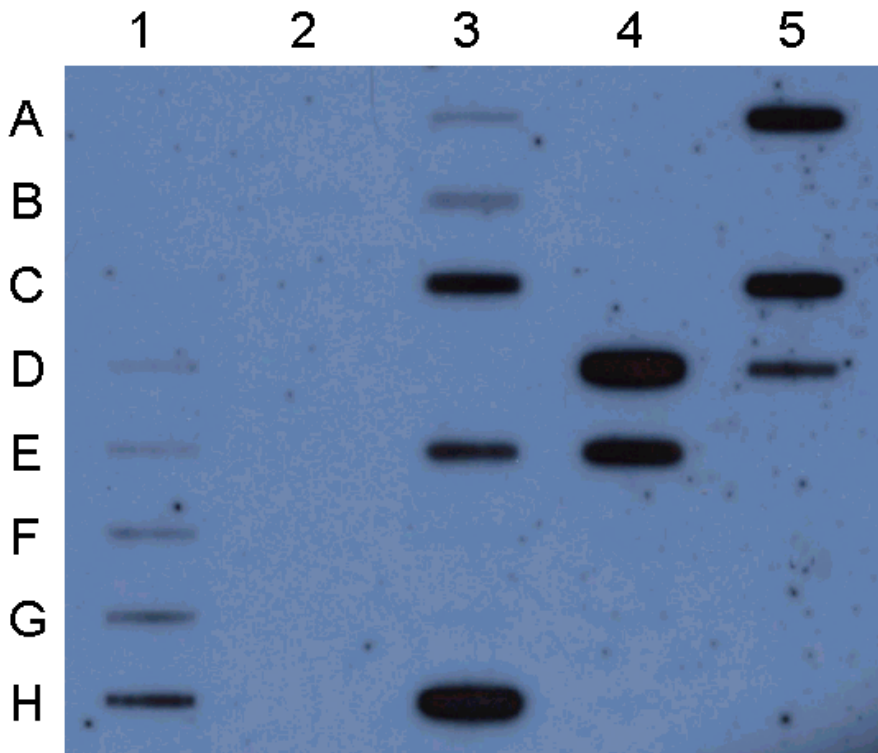
**Figure 5.7** Detection of *E. lata* in DNA extracted from inoculated canes by slot blot analysis using the *E. lata*-specific clone, C68. Slots 1A-2C contain increasing concentrations of genomic DNA from *E. lata* isolate M302; 1, 2.5, 5, 7.5, 10, 12.5, 15, 20, 30, 40, 50 ng respectively. Slots 2D-2H contain dd H<sub>2</sub>O. Slots 3A-3F contain genomic DNA from grapevine, non-*E. lata* isolates 1739, 1740, 1750, 1775, 1785. Slots 3G and 3H contain dd H<sub>2</sub>O. Slots 4A and 4B, 4E-5D contain 200 ng total DNA obtained from inoculated grapevine canes. Slots 4C and 4D contain 200 ng total DNA obtained from uninoculated grapevine canes.



**Figure 5.8** Detection of *E. lata* in DNA isolated from wood obtained from naturally infected grapevines (cv Cabernet Sauvignon) by slot blot analysis using the *E. lata*-specific clone, C68. Slots 1A-1H contain increasing concentrations of genomic DNA from *E. lata* isolate M280; 1, 2.5, 5, 7.5, 10, 12.5, 15 and 20 ng respectively. Slot 2A contains DNA extracted from the centre of the canker in a single diseased cordon, slots 2B-2H contain 200 ng total DNA obtained from asymptomatic wood around the circumference of the infected trunk from which the DNA extract in slot 2A was obtained. Slots 3A-4C contain 200 ng total DNA extracted from the margin of healthy and discoloured wood of 11 infected grapevine trunks. Slots 4D-4H contain dd H<sub>2</sub>O.



**Figure 5.9** Detection of *E. lata* in DNA isolated from grapevine canes inoculated with *E. lata* ascospores, treated with water following inoculation, by slot blot analysis using the *E. lata*-specific clone, C68. Slots 1A-1H contain increasing concentrations of genomic DNA from *E. lata* isolate M280; 1, 2.5, 5, 7.5, 10, 12.5, 15 and 20 ng respectively. Slots 2A-4E contain 200 ng total DNA obtained from 21 inoculated grapevine canes.



**Figure 5.10** Detection of *E. lata* in DNA isolated from grapevine canes inoculated with *E. lata* ascospores and treated with Fungaflor following inoculation, by slot blot analysis using the *E. lata*-specific clone, C68. Slots 1A-1H contain increasing concentrations of genomic DNA from *E. lata* isolate M280; 1, 2.5, 5, 7.5, 10, 12.5, 15 and 20 ng respectively. Slots 2A-5D contain 200 ng total DNA obtained from 28 inoculated grapevine canes.



## 5.4 Discussion

Eight nucleic acid extraction protocols were assessed for their efficacy in the preparation of PCR-competent DNA from grapevine wood. Only the Bio-101 soil DNA extraction kit yielded DNA which allowed reliable detection of the pathogen in infected wood. While it is possible that the SCAR primer pair was not capable of detecting the pathogen in some of these samples due to the small amounts of *E. lata* DNA compared to host DNA, the continued failure to amplify DNA following the seeding of extracts with 10 ng of *E. lata* genomic DNA suggests that this was not the case. Rather, it is likely that polyphenolic compounds, which would inhibit the amplification of DNA, were present in the majority of DNA extracts. It is also possible that the concentration of total DNA (*E. lata* and grapevine) was too high, which may have reduced the efficacy of the reaction. However, PCR experiments conducted using genomic DNA of *E. lata* ranging between 0.75 and 150 ng per reaction showed amplification products in all cases (data not shown), indicating that this was probably not the cause of failed amplification of DNA.

Addition of PVP-10 did enhance the success of the PCR, however, results were inconsistent, even for extracts seeded with *E. lata* DNA. The addition of a range of organic solvents, previously shown to enhance the PCR, to the reaction mixture, was ineffective here. However, it is believed that these compounds may act on melting temperature of primers, or influence the degree of PCR product strand separation during the reaction (Pomp and Medrano, 1991), hence, if the failure of the reaction was due to interference from polyphenolic compounds, these organic additives would not be expected to enhance the procedure.

Although the rapid detection of *E. lata* in infected grapevine tissue using PCR has been reported (Irelan *et al.*, 1999; Lecomte *et al.*, 2000), consistent amplification of *E. lata* DNA using these techniques was not achieved here. However, PCR products of the expected size were obtained in some instances using these protocols, in particular following the addition of PVP to the PCR mixture. The amplification of DNA from some extracts which were seeded with *E. lata* genomic DNA and supplemented with PVP suggests that polyphenolic compounds had inhibited the reaction. However, because the addition of PVP did not overcome the inhibition in all cases, it is likely that the concentration of polyphenolic compounds may have been excessively high. It is believed that, for some reactions, the inhibition may have been due, at least in part, to

the storage of grapevine canes at 4°C for 1-2 weeks prior to DNA extraction. This causes degradation of DNA, and may result in an increase in the amount of inhibitory compounds present in purified DNA. However, this was not the case in all instances, and samples extracted from fresh canes also did not result in the consistent amplification of *E. lata* DNA.

Both the SEAPS extraction protocol (Melanson *et al.*, 2002) and the protocol of Wolf *et al.* (1999) employ CTAB, and have been used to extract DNA from grapevine wood. However, the SEAPS protocol had not been used to isolate DNA for use in PCR, and DNA extracted using this protocol was of insufficient quality for PCR-based assays. Wolf *et al.* (1999) extracted DNA from the wood of grapevine rootstocks, for use in the RAPD-PCR technique (Wolf *et al.*, 1999). However, the published extraction protocol (Wolf *et al.*, 1999) was extremely brief and cited a thesis written in German (Wolf, 1996), which could not be obtained. It is possible that, had full details of the extraction protocol been given, DNA of a quality suitable for use in PCR may have been isolated. Indeed, some samples extracted using this protocol did allow for amplification of *E. lata* DNA from infected wood, although the intensity of DNA bands was very low in all cases.

Many of the protocols which report the extraction of PCR-competent DNA from tissues known to be high in polyphenolic compounds, including grapevine, have used fresh leaf material rather than woody tissue (Manning, 1991; Lodhi *et al.*, 1994; Minsavage *et al.*, 1994; Kim *et al.*, 1997; Zhang *et al.*, 1998; Förster and Adaskaveg, 2000; Vidal *et al.*, 2000; Rott and Jelkmann, 2001). However, wood, in particular that obtained from old vines and from discoloured wood, is expected to have a higher concentration of inhibitory compounds than does leaf tissue. Hence, it is not entirely surprising that DNA of sufficient quality could not be obtained from this material when using techniques developed for the isolation of DNA from young leaves.

Four of the DNA extraction protocols, namely the DNeasy kit, the protocols of Green *et al.* (1999) and Rott and Jelkmann (2001), and the Bio-101 soil DNA extraction kit, utilise the binding of DNA to silica in order to obtain pure DNA. Of these, only the Bio-101 soil DNA extraction kit allowed for successful detection of the pathogen in all 15 samples from which DNA was extracted. However, the cost of this kit (approximately \$ 1,000 for 50 preparations) would preclude it from use in routine



diagnosis. The protocol of Rott and Jelkmann (2001) also allowed for the amplification of *E. lata* DNA from infected wood samples, but not consistently. For example, following the extraction of DNA from 10 infected canes using both of these protocols, *E. lata* DNA was detected in all 10 DNA extracts obtained using the Bio-101 kit, but only in five out of ten following extraction using the protocol of Rott and Jelkmann (2001). It should be noted that the protocol of Rott and Jelkmann (2001) was initially designed for the extraction of RNA. Modifications of this protocol, for example reduction of incubation temperatures from 70°C to 60 or 65°C, which are routinely used for extraction of DNA, and use of a DNA extraction buffer may allow for more efficient isolation of DNA. However, substitution of the original extraction buffer with one used by Manning *et al.* (1991) for the extraction of DNA from wood failed to enhance the success of the reaction (data not shown).

Because of the lack of success in using a PCR-based assay for the detection of *E. lata* in infected wood, a genomic DNA library was generated, from which a DNA clone specific to *E. lata* was selected for use in Southern hybridisation assays (see Chapter 4). The slot blot procedure has been used to detect *P. viticola* following extraction of DNA from infected canes using the SEAPS protocol (Melanson *et al.*, 2002). Hence, the SEAPS DNA extraction protocol was selected to extract DNA from grapevine wood and cane known to be infected with *E. lata*. Southern hybridisation techniques have not previously been used to detect *E. lata* in infected grapevine wood. However, the successful application of this technique in the current study clearly demonstrates the potential of this technique for detecting *E. lata* in infected vines. Probes used in slot blots detected DNA of *E. lata* in 11 trunk samples from which *E. lata* mycelium was isolated, as well as in nine out of 10 grapevine canes which had been inoculated with mycelial plugs of the pathogen in the glasshouse, even though *E. lata* was recovered from only two of these canes. However, it should be noted that as many as 25 wood chips may need to be cultured from each cane to verify the presence of *E. lata* in infected tissue (Petzoldt *et al.*, 1981). Here, only four wood chips were cultured from each cane because of the need to retain material for use in DNA extractions.

Analysis of 1-year-old canes inoculated in the field, and comparison with isolation data for the same material, revealed that the slot blot technique was considerably more sensitive than isolation, in that *E. lata* DNA was detected in 50% of cane samples inoculated with *E. lata*, compared to 23% following isolation onto agar. This figure of

50% is comparable to that obtained in studies carried out in 1980, in which 1-year-old canes were inoculated in the field with 100 ascospores each and *E. lata* subsequently isolated from 40% of wood samples cultured (Moller and Kasimatis, 1980).

The overall figure of 66% infection detected in slot blot analysis of un-inoculated canes seems excessive in comparison with reports that 2-24% of 1-year old canes become naturally infected (Munkvold and Marois, 1993b, 1995; Creaser and Wicks, 2002). As stated in section 5.3.9, DNA of *E. lata* was detected in 95% of DNA samples on the first membrane, and only 14% on the second. The figure of 14% in the second slot blot seems the more credible given that culturing by Dr Creaser revealed an overall infection level of 5% in un-inoculated cane samples. Unfortunately, these membranes could not be replicated because approximately 200 ng of DNA was isolated from each cane sample, and the canes had been discarded following extraction of DNA. The considerable differences between membranes indicates that there may have been some intermingling of DNA extracts on the first membrane, possibly caused by a failure to tighten the slot blot apparatus sufficiently. However, it has also been reported that certain DNA extraction protocols may give non-specific hybridisation in slot blot assays, caused by the presence of co-purified compounds which interfere with the reaction (Gemrich *et al.*, 1993; Tebbe and Vahjen, 1993; Judelson and Messenger-Routh, 1996). Gemrich *et al.* (1993) reported that the co-purification of phenolic compounds in grapevine tissue may also cause a heavy browning of the slots which can clog the membrane. Re-examination of membranes revealed that browning of the slots was evident on the first membrane. Thus, it seems likely that some aspect of the DNA purification protocol was not carried out correctly, and that these samples, all of which were extracted at the same time, may have contained high concentrations of phenolic compounds.

The variation in signal strength observed in Southern hybridisation assays probably reflects the area of the cane or trunk from which the wood samples were taken. DNA was extracted from the same mass of cane (85 mg) in all cases. For extraction of DNA from cane samples, cane was obtained from the margin of dead and healthy tissue, although tissue death was often caused by dieback of canes following pruning, rather than infection with *E. lata* (M. Creaser, *pers. com.*). Hence, the precise location of the pathogen in these canes was not clear. This would have resulted in varying amounts of *E. lata* mycelium in the cane samples and, therefore, varying amounts of *E. lata* DNA

following extraction using the SEAPS protocol. Similar variation in signal strength was observed among samples taken from naturally infected 30-year-old grapevine trunks. Although the majority of these samples was taken from the margin of tissue alongside a canker characteristic of eutypa dieback, due to the tough nature of the wood it was difficult to excise tissue the same distance from the canker in all instances. Hence, variation in signal strength is likely due to a lower density of *E. lata* mycelium in samples taken further away from the canker. When analysing 11 individual infected trunk samples, all wood was taken from around the margin of dead and dying tissue caused by eutypa dieback, because this is the region from which *E. lata* mycelium is most easily cultured from wood-chips. However, when seven samples were taken from around the canker of a single infected trunk and one from dead wood at the centre of the canker, an extremely strong signal was observed when using DNA extracted from the latter (Figure 5.8, slot 2A). Less intense signals were obtained for DNA extracted from two wood samples at the margin of the canker, and no signals were obtained for DNA extracted from wood more distant from the canker. It was interesting to note that approximately 20 ng of total DNA was obtained from dead wood in the canker, however, 200 ng was extracted from all other samples (data not shown). Given the stronger signal in the sample with least DNA, this suggests that DNA from the dead grapevine tissue had degraded and little could be isolated, hence, the majority of DNA probably came from mycelium of *E. lata*.

PCR-based assays have been widely used for the detection of fungal plant pathogens, whereas the use of slot blots and the related dot blot technique (Meinkoth and Wahl, 1984) has been reported less frequently. This is presumably because PCR may have a higher sensitivity, is less time consuming and does not require the use of radioactive isotopes. However, slot- or dot-blots have been used to detect a variety of fungal pathogens, including *Botrytis cinerea* (Mathur and Utkhede, 2002), *Didymella bryoniae* (Koch and Utkhede, 2002), *Gaeumannomyces graminis* (Herdina *et al.*, 1996; Herdina *et al.*, 1997), *Rhizoctonia solani* (Whisson *et al.*, 1995) and *Phytophthora cinnamomi* (Judelson and Messenger-Routh, 1996). In the latter three species, DNA was isolated from soil or infected roots, substrates from which it may be difficult to isolate DNA of sufficient quality for use in PCR. The slot blot technique has not previously been used to detect *E. lata* in infected grapevine tissue, however, it has been used to detect *P. viticola* in infected grapevines (Melanson *et al.*, 2002). Melanson *et al.* (2002) reported considerable variation in the amount of total DNA extracted from different samples,

with lower yields from heavily infected canes. In addition, there was no correlation between the amount of DNA isolated and signal intensity. Similar results were obtained in the current study, where the strongest signal arose from 20 ng of total DNA isolated from the centre of a canker, and much weaker signal was observed in 200 ng samples of DNA extracted from the margins of healthy and discoloured tissue of diseased cordons.

In summary, both the PCR assay and the Southern hybridisation assay developed here are capable of detecting *E. lata* in infected grapevine wood. The only DNA extraction protocol which generated consistent results in a PCR assay was the Bio-101 soil DNA extraction kit, which provided DNA of a quality suitable for PCR amplification without inhibition by phenolic compounds. However, as stated previously, this is not a cost-effective technique for use in routine identification of *E. lata* DNA in the present study. Neither of the published rapid extraction protocols for the detection of *E. lata* DNA in infected grapevine wood resulted in PCR products from grapevine cane known to contain *E. lata*. The use of Southern hybridisation, a technique much less susceptible to inhibition by phenolic compounds, has the potential to allow reliable detection of *E. lata* DNA in artificially inoculated 1-year-old grapevine canes as well as in naturally infected grapevine trunks. Comparison with isolation data provided by Dr Creaser suggested that detection of *E. lata* DNA using Southern hybridisation may be more sensitive than re-isolation into culture and, hence, could provide an accurate and efficient means of assessing both the extent of infection in diseased vines and the efficacy of potential control agents.

---

## Chapter 6 Production of secondary metabolites by *E. lata* on artificial media

---

### 6.1 Introduction

Foliar symptoms of eutypa dieback are caused by the action of translocatable toxins which are produced by the fungus in the vascular tissue and transported to the foliage (Moller and Kasimatis, 1981). The toxicity of *E. lata* culture filtrates towards plant material was first demonstrated by Mauro *et al.* (1988) and Tsoupras *et al.* (1988, see section 1.6). On the basis of that research, it was believed that the acetylenic phenol secondary metabolite eutypine was responsible for the foliar symptoms of eutypa dieback.

One of the initial aims of this project was to develop an early diagnostic test for eutypa dieback based upon the detection of eutypine in the foliage of infected vines. However, as a result of research indicating that eutypine was not produced by all isolates of *E. lata* (Molyneux *et al.*, 2002), secondary metabolite production was instead examined on a range of growth media in order to gain a greater understanding of secondary metabolite production by *E. lata*, and to identify the agents responsible for foliar symptoms of eutypa dieback. The major aim of this section of work was to find a compound present in all isolates which might be suitable for use as a chemical marker in a diagnostic test. Chemical markers have previously been used to detect a range of fungal pathogens, including *Fusarium oxysporum* (Hahn, 2002), *Rhizoctonia* (Raikes and Burpee, 1998) and *Phytophthora* (Fletcher *et al.*, 2001), based on spectral imaging of crops.

As previous research on the production of secondary metabolites by *E. lata* has involved limited numbers of isolates, generally one to three, a range of isolates representing various countries and host plants, was grown on several artificial liquid and solid media, followed by high performance liquid chromatography (HPLC) analysis of phenolic metabolites. This work was conducted in the laboratory of Dr Russell Molyneux, USDA, Albany, California.

## 6.2 Methods

### 6.2.1 Fungal isolates

Eleven isolates were selected based on host species and geographic origin. Included in this study were three isolates previously analysed for secondary metabolite production by Molyneux *et al.* (2002).

### 6.2.2 Growth media

Isolates were grown on four liquid and six solid media (Table 6.1 and Appendix B). Liquid media (50 ml per 250 ml conical flask) were inoculated with 5-8 agar plugs (approximately 2 mm<sup>2</sup>) excised from the margins of actively growing colonies on PDA. Cultures maintained on PDB, MYB, Pezet's broth (Pezet, 1983) and Vogel's broth (Vogel, 1964) were grown in both stationary and shaken conditions (80 rpm). Cultures grown on solid media were initiated by placing an agar plug in the centre of a 90 mm diameter Petri dish.

With the exception of Vogel's broth, all isolates were grown for 30 days, following research by Molyneux *et al.* (2002) which indicated that culture filtrates on MYB and PDB showed maximum secondary metabolite accumulation at around this time. Cultures in Vogel's broth were incubated for 20 and 24 days, following preliminary studies which indicated a decrease in phenolic secondary metabolite production when grown for longer than 20 days. All cultures were incubated in the dark at 25°C. Isolates were also grown in shaken and stationary Vogel's broth amended with XAD™ (5g/50 ml), a polymeric resin expected to absorb compounds such as acetylenic phenols.

**Table 6.1** Fungal growth media used in secondary metabolite analysis

Liquid media	Solid media
Potato dextrose broth (PDB)	Potato dextrose agar (PDA)
Vogel's broth	Vogel's agar
Malt yeast broth (MYB)	½ PDA
Pezet's broth	½ Vogel's agar
Vogel's broth + XAD	¼ PDA
	¼ Vogel's agar

## 6.2.3 Isolation of metabolites

### 6.2.3.1 Liquid media

Liquid cultures were filtered through Whatman no. 4 filter paper, and the filtrate partitioned with an equal volume (50 ml) of diethyl ether. The aqueous phase was discarded and the ether phase partitioned into an equal volume of water. The ether was then removed under reduced pressure using a rotoevaporator. The residue was re-suspended in 15 ml acetonitrile and liquid was removed under reduced pressure. Residues were dissolved in 1 ml of methanol, filtered through a 0.45 µm 13 mm syringe filter (Gelman, USA), and analysed by HPLC as outlined below (section 6.2.4).

### 6.2.3.2 XAD™-amended media

Cultures containing XAD™ were filtered through Whatman no. 4 filter paper and the filtrate discarded. Filtered mycelium and XAD™ were rinsed with 100 ml methanol and then discarded. The methanol filtrate was collected, the solvent removed under reduced pressure and the volume was brought back to 50 ml with water. Samples were partitioned with an equal volume of diethyl ether and extracted as outlined above (section 6.2.3.1).

### 6.2.3.3 Agar media

Colonies were ground in 50 ml methanol, filtered through Whatman no. 4 filter paper, rinsed with a further 50 ml methanol, and the filtrates pooled. The solvent was removed under reduced pressure, and the volume brought to 50 ml with water. Samples were then partitioned with an equal volume of diethyl ether and extracted as outlined above (section 6.2.3.1).

## 6.2.4 HPLC analysis

Samples (20 µl) were analysed on a Hewlett Packard 1100 HPLC system using a Varian Microsorb C18, 5µm, 250 mm x 4.6 mm column. The gradient solvent system consisted of dd H<sub>2</sub>O with 0.5% acetic acid and acetonitrile. A gradient of increasing acetonitrile was used, from 100% dd H<sub>2</sub>O/acetic acid to 100% acetonitrile over 30 min and finally held at 100% acetonitrile for 5 min, with a flow rate of 1.0 ml/min. Secondary metabolites were detected using UV light at 254 nm. Only compounds present in amounts greater than 200 mAU were recorded. Included in each HPLC analysis were four standard compounds previously identified in culture filtrates from *E. lata*, namely eutypinol, eulatachromene, eutypine and a benzofuran (5-formyl-2-methylvinyl (1) benzofuran) (Mauro *et al.*, 1988; Tsoupras *et al.*, 1988; Molyneux *et al.*,

2002). Compounds were identified based on retention times (Rt) relative to these standards. Also included for comparison were siccayne and eulatinol, which were not available when these compounds were analysed, but were subsequently shown to have retention times of 16.8 min and 20.3 min, respectively, when subjected to HPLC under the same conditions (N. Mahoney, *pers. com.*, September 2001). Any compounds which had not previously been characterised in *E. lata* were identified solely on the basis of their retention time.

### **6.2.5 Toxicity of secondary metabolites to grapevine leaf discs**

The toxicity of secondary metabolite extracts produced by each of the 11 isolates grown on PDB, Pezet's and Vogel's broths in shaken and stationary conditions, and on shaken MYB, was analysed using the method developed by Smith *et al.* (2003). Leaf discs (1 cm diameter) were excised from Cabernet Sauvignon vines grown in the glasshouse, taking care to avoid the major veins, using a cork borer. Eleven discs were arranged around the outside of a piece of filter paper (Whatman no. 3) saturated with dd H<sub>2</sub>O (2 ml) in a 90 mm Petri dish. The methanol in which each sample was suspended (1 ml) was removed under vacuum, and residues re-suspended in 20 µl methanol. Aliquots (5 µl) of each sample were applied, as a single droplet, to the centre of each leaf disc. Two control discs in the centre of each plate were treated with either 5 µl methanol or 5 µl of a mixture of eutypinol, eulatachromene, eutypinol and benzofuran, also suspended in methanol. Lids were placed on the Petri dishes, which were incubated on a laboratory bench under 12 h of mixed natural and artificial fluorescent light and 12 h of darkness for 48 h. An additional 1.5 ml of dd H<sub>2</sub>O was added to each dish after 24 h to prevent desiccation of the leaf discs. Discs were visually assessed for the degree of browning 48 h after application of the extracts.

### **6.2.6 Data analysis**

Following growth of isolates on all media, phenolic secondary metabolites were scored as being either present (1) or absent (0), to form a binomial representation of secondary metabolite profiles. Pairwise comparisons were made between all isolates using the algorithm of Nei and Li (1979) and data was analysed using the methods outlined in section 3.2.6.1.



## 6.3 Results

Following growth of the 11 isolates on all media, 41 different phenolic secondary metabolites were produced in amounts greater than 200 mAU. These included eutypinol, siccayne, eulatachromene, eutypine, eulatinol and benzofuran, all of which have previously been detected in culture filtrates of *E. lata* (Renaud *et al.*, 1989b; Molyneux *et al.*, 2002). The remaining 35 compounds have not been characterised and were identified on the basis of retention time only. Nineteen of these 35 compounds were produced by a single isolate only, although not the same isolate in each case. The presence or absence of metabolites for each isolate/media combination is shown in Table 6.2. It is apparent that different media stimulated the production of different secondary metabolites, even following growth of the same isolate on different media. Differences in phenolic secondary metabolite production following growth of all 11 isolates on both liquid and solid media are discussed in sections 6.3.1 and 6.3.2. Selected chromatograms showing HPLC profiles of all isolates are presented in sections 6.3.1 and 6.3.2, the remainder are given in Appendix C.

### 6.3.1 Production of secondary metabolites on liquid media

Both medium (PDB, MYB, Pezet's and Vogel's broths) and environment (shaken or stationary) strongly influenced the amount and composition of secondary metabolites produced by the 11 isolates. There was no consistent correlation between either shaken or stationary conditions and the amount or type of secondary metabolites produced.

Secondary metabolite production by all 11 isolates grown in liquid media in both shaken and stationary conditions is summarised in Table 6.3. No single isolate produced significant quantities of secondary metabolite on every medium, although isolate E125 did so on all except stationary Pezet's broth, and M280 on all except stationary PDB. Least prolific was isolate SS1#1, which produced detectable compounds in two media only. PDB and MYB, with cultures shaken, were the media most conducive to the production of secondary metabolites, with 10 isolates producing detectable compounds on each of these media. Isolate E178 did not produce secondary metabolites in shaken PDB and isolate M335 did not produce secondary metabolites in shaken MYB.



Presence/absence of metabolites for fungal isolate/source											
Media/ Metabolite (Rt)	E1 Australia Apricot	E120 California Grape	E125 Italy Grape	E178 California Oak	M266 France Grape	M279 Australia Apricot	M280 Australia Grape	M335 Australia Grape	NO4 Australia Grape	SS1#1 NZ Grape	SS6 Australia Grape
MYB (stationary, 30 days)											
15.1	+	+	+	+	+	-	-	-	-	-	-
18.3	+	-	-	-	+	-	-	-	-	-	-
19.6	+	-	-	-	-	-	-	-	-	-	-
19.9 (eutypine)	+	-	-	-	+	-	-	-	-	-	-
20.4 (eulatinol)	+	+	+	-	-	-	+	-	-	-	-
21.6	-	+	-	-	-	-	-	-	-	-	-
22.5	+	-	-	-	-	-	-	-	-	-	-
23.0	+	-	-	-	+	-	-	-	-	-	-
23.4	+	-	-	-	+	-	-	-	-	-	-
24.9 (benzofuran)	+	-	-	-	+	-	-	-	-	-	-
25.2	+	+	+	-	-	-	-	-	-	-	-
MYB (shaken, 30 days)											
15.1	+	-	-	-	+	+	+	-	+	+	+
15.2	-	-	+	-	-	-	-	-	-	-	-
16.5 (eutypinol)	-	-	-	-	+	-	-	-	-	-	-
16.7	-	-	-	+	-	-	-	-	-	-	-
17.3	+	-	+	-	+	+	+	-	+	-	-
18.4	-	-	-	+	-	-	-	-	-	-	-
20.3 (eulatinol)	-	+	-	-	-	-	-	-	-	-	-
27.9	-	-	-	+	-	-	-	-	-	-	-
28.3	-	-	-	+	-	-	-	-	-	-	-

Presence/absence of metabolites for fungal isolate/source

Media/ Metabolite (Rt)	E1 Australia Apricot	E120 California Grape	E125 Italy Grape	E178 California Oak	M266 France Grape	M279 Australia Apricot	M280 Australia Grape	M335 Australia Grape	NO4 Australia Grape	SS1#1 NZ Grape	SS6 Australia Grape
---------------------------	----------------------------	-----------------------------	------------------------	---------------------------	-------------------------	------------------------------	----------------------------	----------------------------	---------------------------	----------------------	---------------------------

Pezet's broth (stationary, 30 days)

16.0	-	-	-	-	-	-	+	-	+	-	-
16.5 (eutypinol)	-	-	-	-	-	+	-	-	-	-	+
17.9	-	+	-	-	-	-	-	-	-	-	-
18.3	-	-	-	-	-	+	-	-	-	-	-
19.7	-	-	-	-	-	+	-	-	-	-	-
19.9 (eutypine)	-	-	-	-	-	+	-	-	-	-	-
20.4 (eulatinol)	-	-	-	-	-	+	-	-	+	-	-
25.2	-	-	-	-	-	+	-	-	-	-	-

Pezet's broth (shaken, 30 days)

11.1	-	-	+	-	-	-	-	-	-	-	+
14	-	-	+	-	-	+	+	-	-	-	-
14.3	-	-	-	+	-	-	-	-	-	-	-
16	-	-	+	-	-	-	-	-	-	-	-
16.5 (eutypinol)	-	-	+	-	-	+	+	-	+	-	+
18.3	-	-	-	-	-	-	+	-	-	-	-
18.7 (eulatachromene)	-	-	+	-	-	-	-	-	-	-	-
23.9	-	-	-	-	-	-	-	+	-	-	-

Presence/absence of metabolites for fungal isolate/source												
Media/ Metabolite (Rt)	E1 Australia Apricot	E120 California Grape	E125 Italy Grape	E178 California Oak	M266 France Grape	M279 Australia Apricot	M280 Australia Grape	M335 Australia Grape	NO4 Australia Grape	SS1#1 NZ Grape	SS6 Australia Grape	
Vogel's broth (stationary, 20 days)												
14.1	+	-	-	-	+	-	-	-	-	-	-	
15.2	-	-	+	-	-	-	-	-	-	-	-	
16.5 (eutypinol)	+	-	+	-	+	-	+	-	+	-	-	
18.3	+	-	-	-	+	-	-	-	-	-	-	
19.7	+	-	+	-	-	-	-	-	-	-	-	
19.9 (eutypine)	+	-	+	-	+	-	-	-	-	-	-	
20.4 (eulatinol)	-	-	+	-	-	-	+	-	-	-	-	
20.9	-	-	+	-	-	-	-	-	-	-	-	
24.5	-	-	-	-	-	-	-	+	-	-	-	
25.1	-	-	+	-	-	-	-	-	-	-	-	
25.3	-	-	-	-	-	-	-	-	-	-	+	
Vogel's broth (stationary, 24 days)												
15.2	-	-	+	-	-	-	-	-	-	-	-	
16.5 (eutypinol)	-	-	-	-	+	-	-	-	-	-	-	
19.7	+	-	-	-	-	-	-	-	-	-	-	
19.9 (eutypine)	+	-	-	-	+	-	-	-	-	-	-	
20.4 (eulatinol)	-	+	-	-	-	-	+	-	-	-	-	
20.8	+	-	-	-	-	-	-	-	-	-	-	
21.6	-	+	-	-	-	-	-	-	-	-	-	
22.6	+	-	-	-	-	-	-	-	-	-	-	
23.4	+	-	+	-	-	-	-	-	-	-	-	
25.2	+	+	-	-	-	+	+	-	-	-	+	

Presence/absence of metabolites for fungal isolate/source											
Media/ Metabolite (Rt)	E1 Australia Apricot	E120 California Grape	E125 Italy Grape	E178 California Oak	M266 France Grape	M279 Australia Apricot	M280 Australia Grape	M335 Australia Grape	NO4 Australia Grape	SS1#1 NZ Grape	SS6 Australia Grape
Vogel's broth (stationary, 30 days)											
16.5 (eutypinol)	-	-	+	-	-	-	-	-	-	-	-
18.3	-	-	-	-	+	-	-	-	-	-	-
19.9 (eutypine)	-	-	+	-	+	-	-	-	-	-	-
20.3 (eulatinol)	-	-	-	-	-	-	+	-	-	-	-
20.8	+	-	-	-	-	-	-	-	-	-	-
23.5	+	-	-	-	-	-	-	-	-	-	-
25	-	-	+	-	-	-	-	-	-	-	-
25.2	-	-	-	-	-	-	-	-	-	-	+
Vogel's broth (shaken, 20 days)											
15.2	-	-	+	-	-	-	-	-	-	-	-
16.5 (eutypinol)	-	-	-	-	-	-	+	-	-	-	-
20.3 (eulatinol)	+	-	-	-	-	-	+	-	-	-	-
Vogel's broth (shaken, 24 days)											
15.2	-	-	+	-	-	-	-	-	-	-	-
16.7	-	-	-	+	-	-	-	-	-	-	-
19.7	+	-	-	-	-	-	-	-	-	-	-
20.4 (eulatinol)	+	+	-	-	-	+	+	-	-	-	-
21.6	+	-	-	-	-	-	-	-	-	-	-
24.5	-	-	-	-	-	-	-	+	-	-	-
25.2	+	+	-	-	-	+	-	-	-	-	-

Presence/absence of metabolites for fungal isolate/source											
Media/ Metabolite (Rt)	E1 Australia Apricot	E120 California Grape	E125 Italy Grape	E178 California Oak	M266 France Grape	M279 Australia Apricot	M280 Australia Grape	M335 Australia Grape	NO4 Australia Grape	SS1#1 NZ Grape	SS6 Australia Grape
27.9	-	-	-	+	-	-	-	-	-	-	-
PDA (30 days)											
14.1	+	+	-	-	-	-	+	-	-	-	-
16.5 (eutypinol)	+	+	+	-	+	-	+	-	-	-	+
17.7	-	-	-	-	-	-	-	+	-	-	-
18.0	-	-	-	-	-	-	-	+	-	-	-
19.7	+	-	+	-	-	+	-	-	-	-	-
20.4 (eulatinol)	-	-	-	-	-	-	-	-	-	-	+
23.0	-	-	+	-	-	-	-	-	-	-	-
Vogel's agar (30 days)											
19.9 (eutypine)	-	-	+	-	-	-	-	-	-	-	-
20.3 (eulatinol)	-	-	+	-	-	-	-	-	-	-	-
20.5	-	-	-	-	-	-	+	-	-	-	-
25.0	-	-	+	-	-	-	-	-	-	-	-
25.2	+	-	-	-	-	-	-	-	-	-	-
25.3	-	-	-	-	-	-	-	-	+	-	-
28.0	-	-	-	+	-	-	-	-	-	-	-
$\frac{1}{2}$ strength PDA, 30 days											
14.1	-	+	-	-	-	-	+	-	-	-	-
16.5 (eutypinol)	-	+	+	-	-	-	+	-	-	-	-
19.7	-	-	-	-	-	+	-	-	-	-	-

In general, isolates which produced secondary metabolites on more media also tended to produce larger quantities of secondary metabolite. For example, isolate E125 produced secondary metabolites in concentrations as high as 5800 mAU, whereas isolate SS1#1 produced a maximum of approximately 730 mAU. Isolates M335 and N04, each of which produced secondary metabolites on five media, produced maximum amounts of approximately 1150 and 1400 mAU, respectively.

No single compound was produced by all isolates, although one compound (Rt 15.1) was produced by all isolates except M335. However, this compound was present following growth of isolates on MYB only and, in some instances, was present in trace amounts of less than 200 mAU. Eutypinol was produced by eight of the 11 isolates (E1, E125, M266, M279, M280, N04, SS1#1 and SS6). Of the other compounds which have been characterised in *E. lata*, eutypine was produced by five isolates (E1, E125, M266, M279 and SS6), siccayne by seven isolates (E1, E120, E125, M266, M280, N04 and SS1#1), eulatinol by seven isolates (E1, E120, E125, M279, M280, N04 and SS6), benzofuran by two isolates (E1 and M266), and eulatachromene by one isolate (E125). No other compounds were produced by more than six of the 11 isolates. There was considerable variation between isolates in terms of the complexity of secondary metabolite profiles. This variation is illustrated in section 6.3.1.1.

### **6.3.1.1 Variation in secondary metabolite production between isolates grown on liquid media**

#### **Potato dextrose broth**

When grown on stationary PDB, two secondary metabolites were produced, one each by isolate E125 (siccayne, Rt 16.9) and M335 (unidentified, Rt 23.9). In shaken PDB, secondary metabolite production was more diverse, with 10 isolates producing seven different secondary metabolites between them. These included eutypinol (Rt 16.5) and siccayne (Rt 16.9), both produced by seven isolates, although the same isolates did not necessarily produce both compounds. Eulatinol (Rt 20.3) was present in six isolates. The remaining four compounds were present in single isolates only. Metabolite concentrations were significantly higher in shaken PDB than in stationary. For example, isolate E125 produced siccayne on both media, but at a concentration of 880 mAU on stationary broth and 5800 mAU on shaken broth.



**Table 6.3** Summary of secondary metabolite production by all isolates grown on all artificial liquid media tested.

	PDB stationary	PDB shaken	MYB stationary	MYB shaken	Pezet's stationary	Pezet's shaken	Vogel's stationary 20 days	Vogel's stationary 24 days	Vogel's shaken 20 days	Vogel's shaken 24 days	Vogel's stationary 30 days
E1	-	+	+	+	-	-	+	+	+	+	+
E120	-	+	+	+	+	-	-	+	-	+	-
E125	+	+	+	+	-	+	+	+	+	+	+
E178	-	-	+	+	-	+	-	-	-	+	-
M266	-	+	+	+	-	-	+	+	-	-	+
M279	-	+	-	+	+	+	-	+	-	+	-
M280	-	+	+	+	+	+	+	+	+	+	+
M335	+	+	-	-	-	+	+	-	-	+	-
N04	-	+	-	+	+	+	+	-	-	-	-
SS1#1	-	+	-	+	-	-	-	-	-	-	-
SS6	-	+	-	+	+	+	+	+	-	-	+

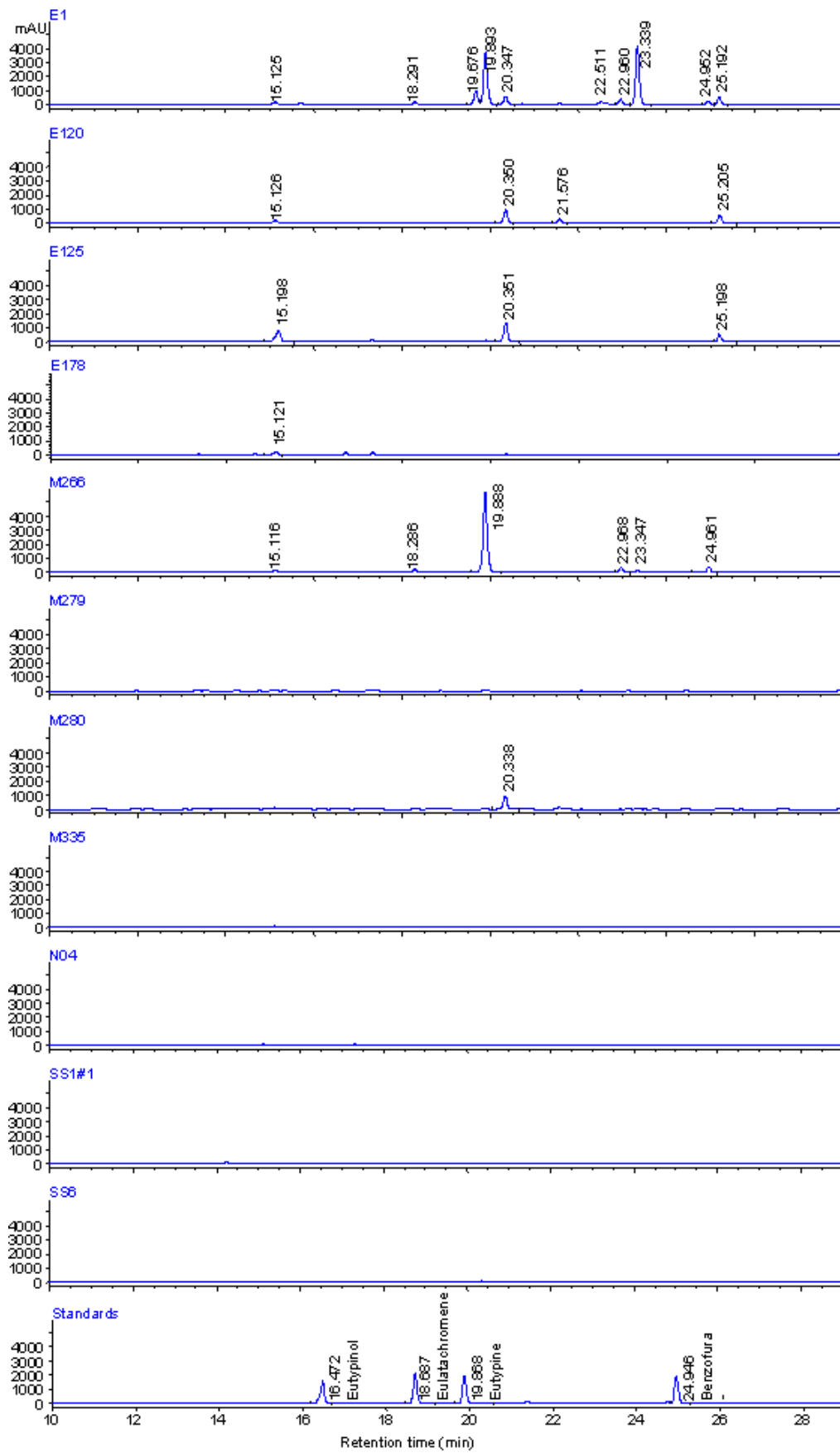
Production of secondary metabolites on different media, as detected by HPLC, is indicated by "+", absence is indicated by "-".

**Malt yeast broth**

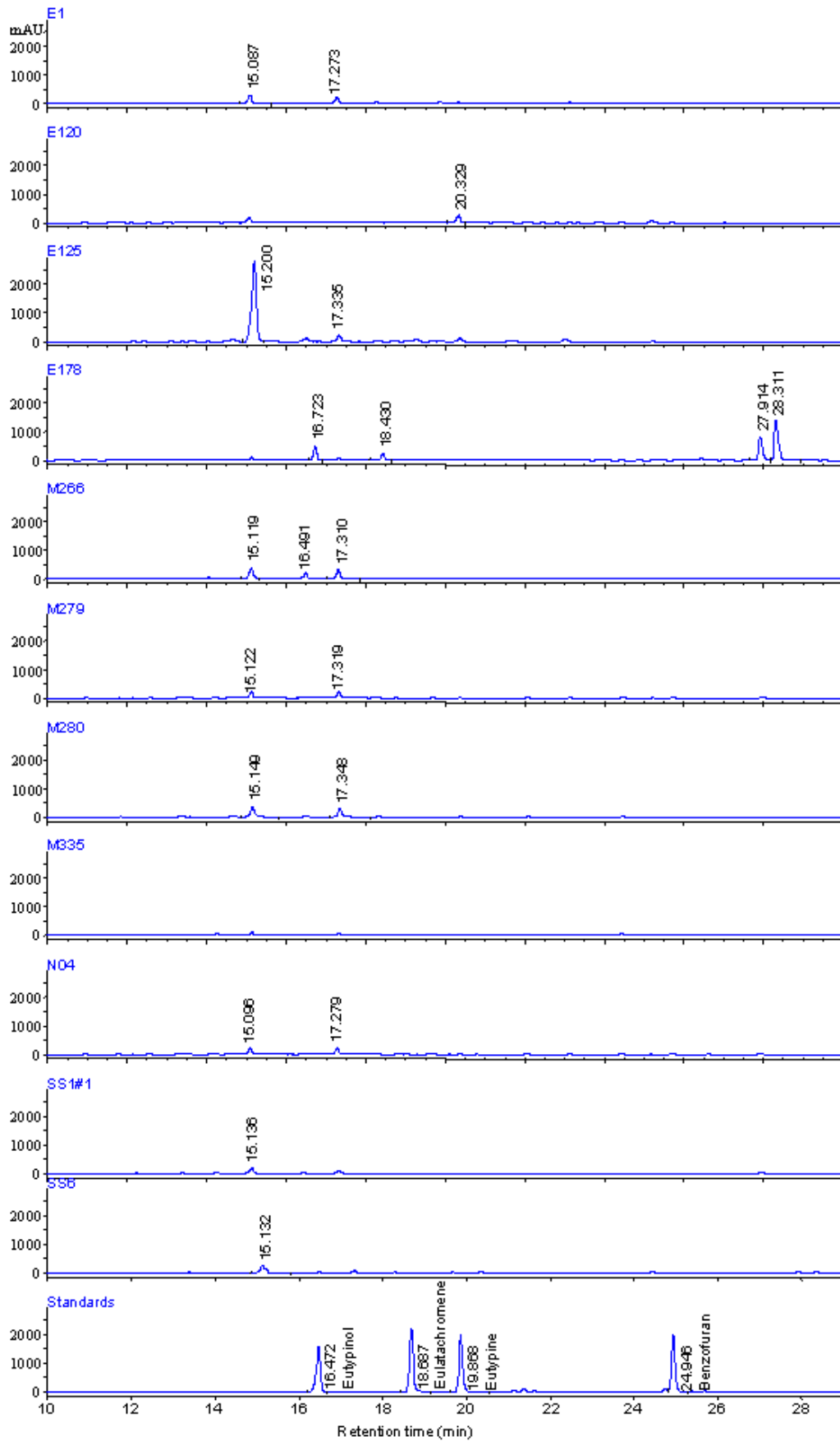
On stationary MYB, six isolates produced 11 different compounds between them. These included eulatinol, produced by four isolates (E1, E120, E125 and M280) and eutypine (Rt 19.9) and benzofuran (Rt 24.9), both produced by isolates E1 and M266. The structures of the remaining eight compounds are unknown. On shaken MYB, nine compounds were detected, and only one isolate (M335) produced no metabolites. One compound (Rt 15.1) was produced by seven isolates. This was also produced by five isolates in the stationary broth, and was the only compound present following growth on both shaken and stationary MYB. Another compound, Rt 17.3, was produced by six isolates on the shaken broth. The remaining compounds were produced by single isolates only. Secondary metabolite profiles of all 11 isolates following growth on shaken and stationary MYB, which illustrate variation both between isolates and between shaken and stationary growth conditions, are shown in Figures 6.1 and 6.2.

**Pezet's broth**

On stationary Pezet's broth, five isolates produced eight different metabolites between them. These included eutypinol (M279 and SS6), eutypine (M279) and eulatinol (M279). Apart from isolate M279, which produced six compounds, no isolate produced more than two secondary metabolites. Similarly, eight metabolites were present following growth in shaken Pezet's broth. Three of these, including eutypinol, were also produced on the stationary medium although they were not produced by the same isolates in each case. In shaken Pezet's broth, eutypinol was the most common compound, produced by five isolates (E125, M279, M280, N04 and SS6). Eulatachromene (Rt 18.7) was produced by one isolate (E125). Three metabolites (eutypinol, unidentified; Rt 16.0, unidentified; Rt 18.3) were produced by isolates grown on shaken and stationary broths, but were not always produced by the same isolates, and were present in higher concentrations in the shaken broth.



**Figure 6.1** HPLC chromatograms showing secondary metabolite production of 11 isolates of *E. lata* grown on stationary MYB for 30 days.



**Figure 6.2** HPLC chromatograms showing secondary metabolite production of 11 isolates of *E. lata* grown on shaken MYB for 30 days.

**Stationary Vogel's broth (20, 24 and 30 days)**

Eleven compounds were produced by six isolates following growth for 20 days in stationary Vogel's broth. These included eutypinol (isolates E1, E125, M266, M280 and N04), eutypine (isolates E1, E125 and M266) and eulatinol (E125 and M280). Five unidentified compounds were each produced by a single isolate, two were produced by two isolates, and one by three isolates. A total of nine isolates produced compounds on this medium. Most prolific was isolate E125 which produced seven different compounds. Ten compounds were produced by seven isolates grown in stationary Vogel's broth for 24 days. Five of these compounds were also present in the 20-day-old broth culture. One compound (Rt 25.2) was produced by five isolates, all other compounds were produced by either one or two isolates. For example, eutypine was produced by isolates E1 and M266, eulatinol by E120 and M280 and eutypinol by M266. Five isolates produced eight secondary metabolites after growth for 30 days in stationary Vogel's medium, for example eutypine was produced by isolates E125 and M266, eutypinol by isolate E125 and eulatinol by isolate M280. Secondary metabolite concentrations were generally lower in the 24 and 30-day-old cultures than in the 20-day-old cultures.

**Shaken Vogel's broth (20 and 24 days)**

Three compounds were produced following 20 days of growth in shaken Vogel's broth. These included eutypinol (M280), eulatinol (E1 and M280) and one unidentified compound, Rt 15.2 (E125). Metabolite profiles were more diverse following growth for 24 days, with eight secondary metabolites being produced by seven isolates. Most diverse was isolate E1 which produced four compounds, other isolates produced either one or two secondary metabolites. Eulatinol was produced by four isolates (E1, E120, M279 and M280), however, none of the other standard compounds previously characterised in *E. lata* filtrates were present following 24 days growth.

**Vogel's with XAD**

No compounds were present in shaken Vogel's broth amended with XAD, however, in the stationary broth three isolates (E1, E125 and M266) produced eutypinol, and isolate M280 produced an unidentified compound, Rt 16.9 (data not shown).

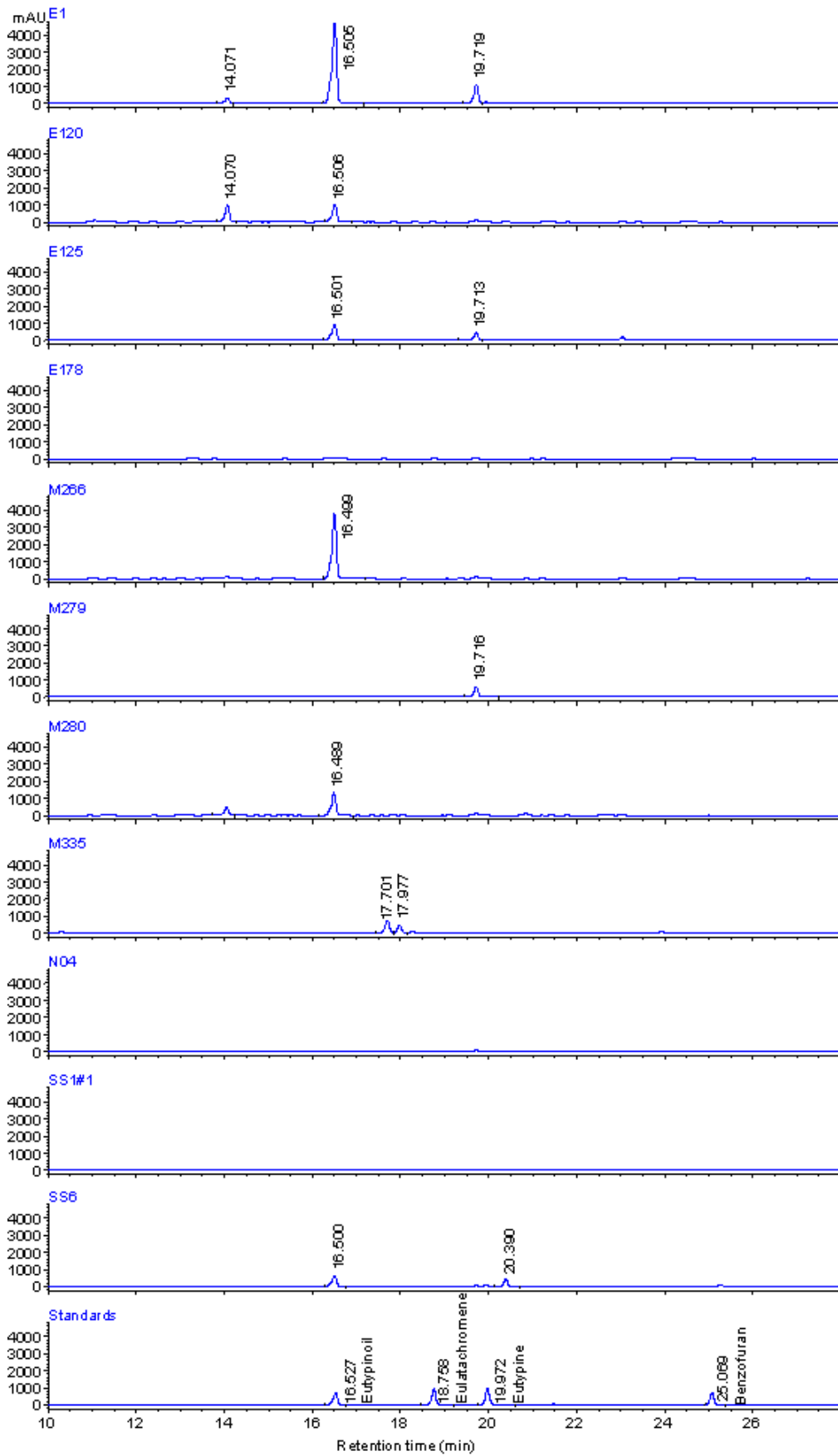
### **6.3.2 Solid media**

#### **PDA (30 days)**

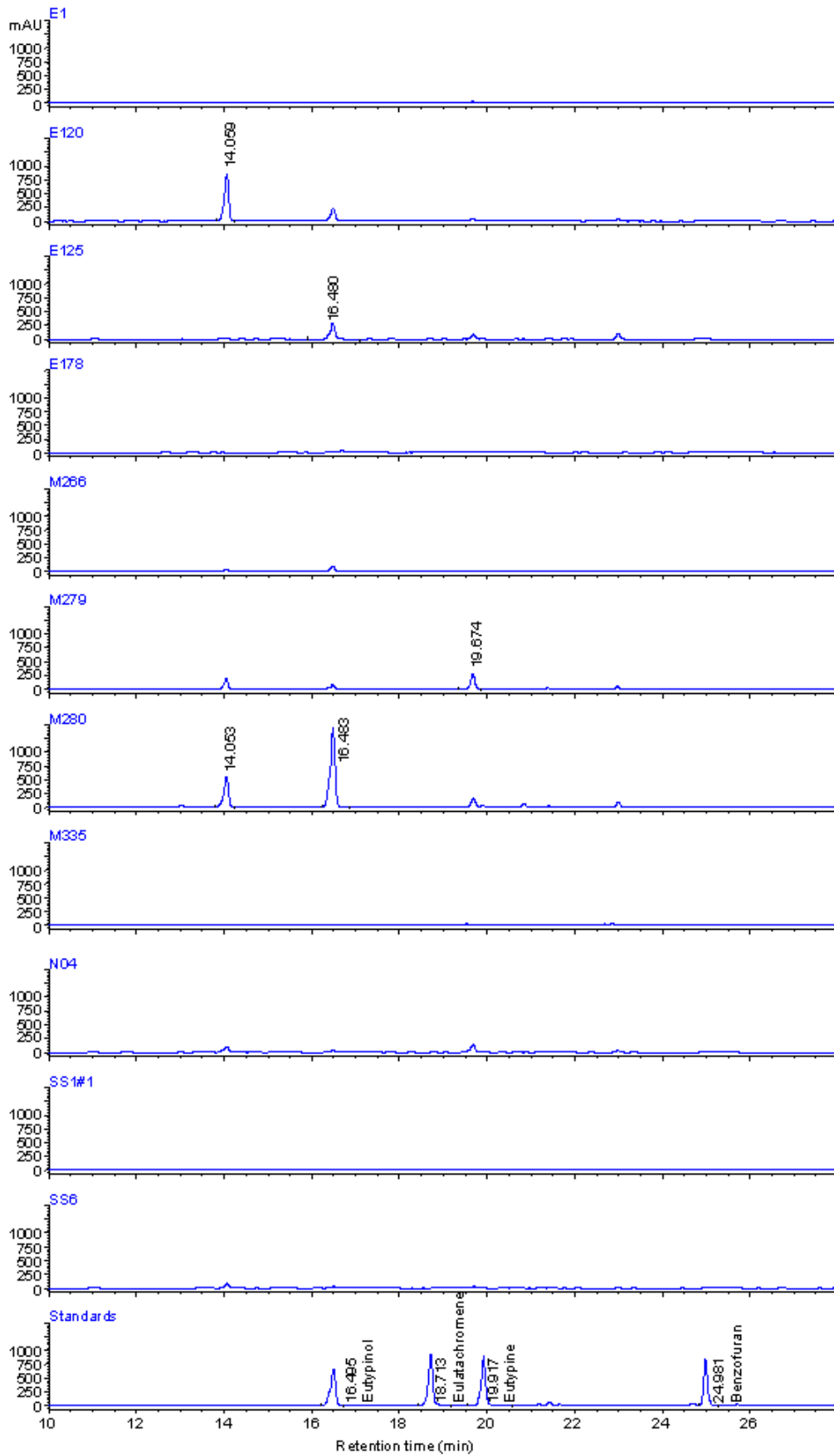
Eight isolates produced secondary metabolites on full strength PDA (Figure 6.3). Six isolates produced eutypinol (E1, E120, E125, M266, M280 and SS6). Two unidentified compounds, with retention times of 14.1 and 19.7 min, were produced by three isolates, although the same isolates did not produce both compounds. The remaining four compounds were each produced by a single isolate. On half strength PDA, four isolates (E120, E125, M279 and M280) produced three secondary metabolites between them (Figure 6.4). Eutypinol was produced by three isolates (E120, E125 and M280). Each isolate which produced metabolites on the half strength media produced the same compounds, but in larger quantities, on full strength PDA. No secondary metabolites were detected following growth on  $\frac{1}{4}$  strength PDA (data not shown).

#### **Vogel's agar (30 days)**

Five isolates produced secondary metabolites on Vogel's agar. These included eutypine and benzofuran, both produced by isolate E125, which also produced eulatinol. The remaining four isolates each produced a single, unidentified secondary metabolite, all in quantities of less than 400 mAU. No secondary metabolites were detected following growth on  $\frac{1}{2}$  and  $\frac{1}{4}$  strength Vogel's agar (data not shown).



**Figure 6.3** HPLC chromatograms showing secondary metabolite production of 11 isolates of *E. lata* grown on PDA for 30 days.

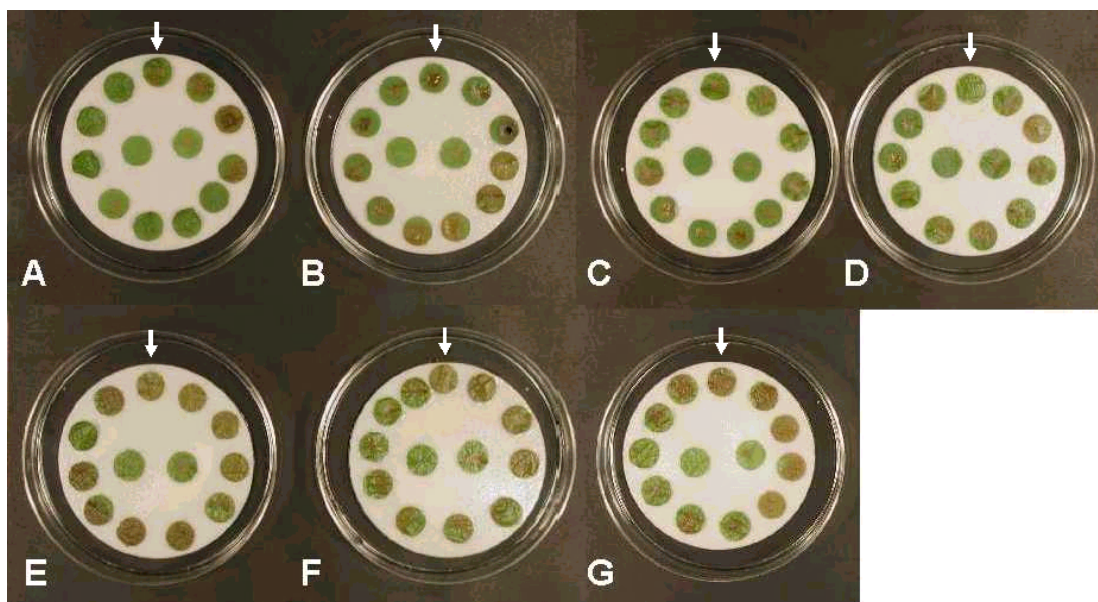


**Figure 6.4** HPLC chromatograms showing secondary metabolite production of 11 isolates of *E. lata* grown on ½ PDA for 30 days.



### 6.3.3 Toxicity of secondary metabolites towards grapevine leaf discs

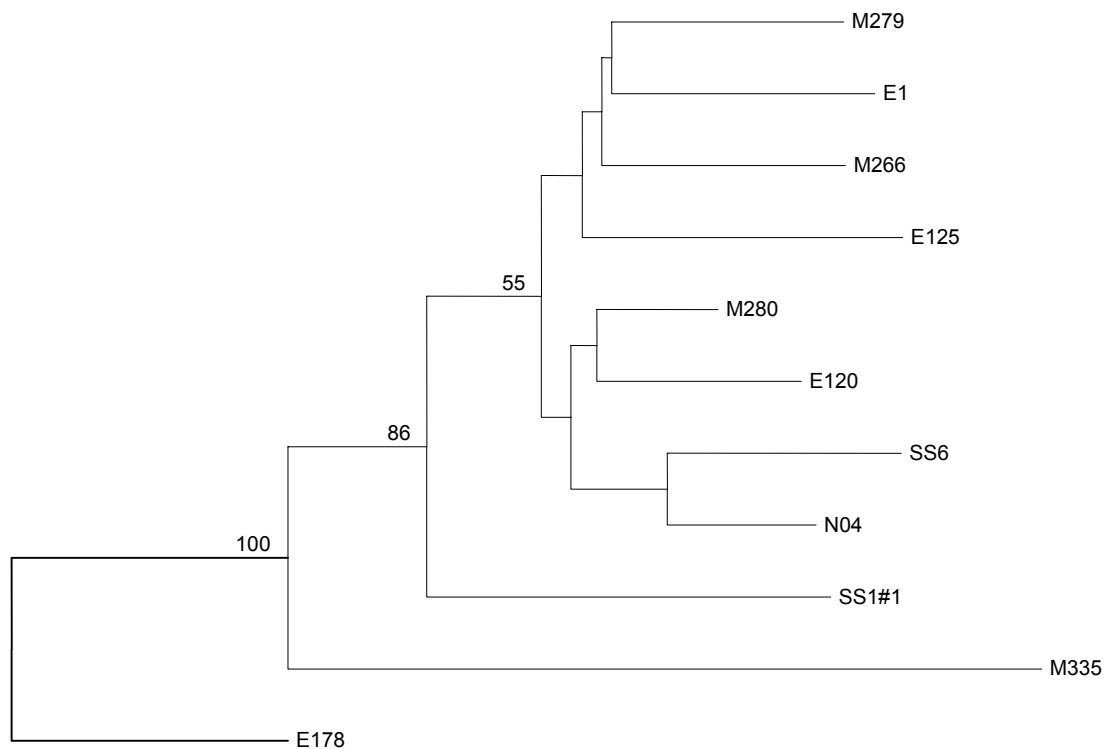
The phytotoxicity of total secondary metabolite extracts from all isolates grown in liquid culture towards grapevine leaf discs is shown in Figure 6.5. In no instance did the methanol-treated control discs exhibit phytotoxicity. Discs treated with a mixture of four characterised secondary metabolites from *E. lata* (positive control) developed a clearly defined area of necrosis in the centre of each leaf disc tested. Following growth on stationary PDB, filtrates from isolates E1, E120, E125, E178 and M335 showed marked phytotoxicity towards the leaf discs. The filtrate from isolate SS1#1 exhibited slight phytotoxicity, however, this was primarily around the veins near the edge of the disc, and it is likely that this was a result of the suspension spreading over the disc and entering directly through the wounded tissue. Filtrates from all isolates grown in shaken PDB were toxic towards leaf discs, even though not all isolates produced detectable quantities of acetylenic phenol secondary metabolites. Similar results were obtained for filtrates of cultures grown in stationary and shaken Pezet's broth, where the filtrate from isolate E1 grown in shaken medium was the only one not to exhibit phytotoxicity. Of the filtrates obtained from isolates grown on Vogel's broth for 24 days, only one isolate (SS1#1 on the stationary broth) was not toxic towards the leaf disc. On stationary MYB, all filtrates were toxic towards the leaf discs. However, the filtrate from isolate N04 showed only limited phytotoxicity around the edges of the disc, probably caused by direct entry of the filtrate into wounded tissue. Unfortunately, due to the unintended destruction of the glasshouse material from which the leaf discs were sourced, secondary metabolite extracts from isolates grown in shaken MYB and on PDA and Vogel's agar were not subjected to analysis for phytotoxicity.



**Figure 6.5** Phytotoxicity of culture filtrates from 11 isolates of *E. lata*, grown on liquid media, towards leaf discs excised from Cabernet Sauvignon grapevines grown in the glasshouse. Culture filtrate of the test isolates was applied to the disc as follows (clockwise from the top centre disc, marked with an arrow, on each Petri dish): E1, E120, E125, E178, M266, M279, M280, M335, N04, SS1#1, SS6. Cultures were grown in: A, stationary PDB; B, shaken PDB; C, stationary Pezet's broth; D shaken Pezet's broth; E, stationary Vogel's broth (24 days); F shaken Vogel's broth (24 days); G, stationary MYB. In the centre of each Petri dish are (left) methanol control and (right) a mixture of *E. lata* metabolites eutypinol, eulatachromene, eutypine and benzofuran. Photographs were taken 48 h after application of filtrates.

### 6.3.4 Data analysis

Neighbour joining analysis was conducted in order to determine whether there was any relationship between secondary metabolite profiles and either host species or geographic origin of each isolate. For these analyses, isolate E178 was defined as the outgroup. Isolate M335, which produced only four secondary metabolites following growth on all media, was shown to be distinct from all other isolates (Figure 6.6). This distinction was strongly supported by a bootstrap value of 100%. Isolate SS1#1, now believed to be *Cryptovalsa ampelina* (see Chapters 3 and 4), was grouped apart from the remaining isolates of *E. lata*, supported by a bootstrap value of 86%. The remaining eight isolates were placed in a single group, weakly supported by a bootstrap value of 55%. No other groupings were supported by bootstrap values of over 50%.



**Figure 6.6** Neighbour joining tree generated using TREECON (Van de Peer and De Wachter, 1994), calculated using presence/absence data of secondary metabolites from 11 fungal isolates following growth on all artificial media. Isolate E178 was specified as the outgroup. Distances were calculated using the algorithm of Nei and Li (1979). Bootstrap values greater than 50% are given.

## 6.4 Discussion

Prior to the research of Molyneux *et al.* (2002), secondary metabolite production by *E. lata* had been analysed following growth on the defined medium of Pezet (1983). No information was given regarding the isolates of *E. lata* used in these analyses, and these may have been conducted using a single isolate. It was largely on the basis of this research that eutypine was implicated as the sole compound responsible for the foliar symptoms of eutypa dieback. In the current study, following growth of 11 isolates on Pezet's broth in both stationary and shaken conditions, only one isolate (M279) produced eutypine. The French isolate tested here (M266) did not produce eutypine following growth on Pezet's broth, although it did do so on stationary MYB and in Vogel's broth. This highlights the problems which may be encountered when using only one isolate/medium combination to evaluate production of phenolic metabolites. In this study, 41 different phenolic metabolites were detected in culture filtrates of *E. lata*. The diversity of secondary metabolite production by *E. lata* observed here emphasises the importance of analysing a range of isolates, grown on a range of media, in order to gain an understanding of the variety of compounds that *E. lata* is capable of producing.

As in research conducted by Molyneux *et al.* (2002), eutypine was not produced by all isolates. Following growth on all media, five of the 11 isolates produced eutypine, whereas eutypinol was produced by eight isolates. It was interesting to note that isolate E120 did not produce eutypinol on either MYB or PDB in the current study, despite the fact that it has previously been shown to do so on both these media (Molyneux *et al.*, 2002). However, Molyneux *et al.* (2002) maintained isolates at 20°C, whereas 25°C was used in the current study. While temperature has previously been shown to influence secondary metabolite production by fungi (Baxter *et al.*, 1998; Aldred *et al.*, 1999), this variable was not assessed here due to limited resources.

Of the other compounds which have previously been characterised in *E. lata*, siccayne and eulatinol were produced by seven isolates and eulatachromene by one isolate. Benzofuran was detected in extracts from three isolates. This compound had not previously been detected in culture filtrates of *E. lata*, although its presence had been postulated by Molyneux *et al.* (2002). Given the ready conversion of eutypine to benzofuran under mildly acidic conditions (Renaud *et al.*, 1989b; Molyneux *et al.*, 2002), it is possible that the presence of benzofuran was a result of the cyclisation of eutypine in the culture medium. However, if this was the case, then benzofuran would be expected in all eutypine-producing isolates.

No compounds were produced by all isolates, although one uncharacterised compound (Rt 15.1) was produced by all isolates except M335. However, this compound was only present following growth on MYB and, in some isolates, was present in trace amounts only (less than 200 mAU), hence peaks are not visible on the chromatograms given in section 6.3.1 for these isolates. Given the variability of secondary metabolite production on the culture media tested here, it is possible that compounds such as this, which were produced on only one medium, may be an artefact of the medium upon which the fungus is grown.

It should be noted that when making comparisons between amounts of compounds, concentrations were discussed in terms of mAU. While this is an appropriate method for comparing amounts of compounds with the same retention time between different chromatograms, concentrations of different compounds within the same chromatogram are not strictly comparable. This is because different compounds have different extinction coefficients at 254 nm hence, a compound with a higher extinction

coefficient may appear to be present at higher levels than one with a lower coefficient at the same wavelength. However, because they are structurally related, the UV spectra of all compounds are similar, allowing rough comparisons to be made (R. Molyneux, *pers. com.*, March 2003).

Previously, when examining sterol production by *E. lata*, Chapuis *et al.* (1996) observed that secondary metabolite production was greater on solid media (malt agar) than on inorganic liquid media. However, the same compounds were produced on both liquid and solid media. This was not the case in the current study, where secondary metabolite production was generally more diverse on solid media. It should be noted, however, that Chapuis *et al.* (1996) analysed a single isolate of *E. lata*, and did not use the same medium in both liquid and solid conditions in their comparison between solid and liquid cultures.

Half and quarter strength PDA and Vogel's agar were included to determine whether nutrient stress enhanced the production of secondary metabolites. However, the dramatic decline in secondary metabolite production on these media indicated that this was not the case. Similarly, Vogel's medium amended with XAD was included to determine whether the sequestration of metabolites as they were produced increased secondary metabolite production, however, this also was not the case.

In this study, when analysing secondary metabolite production following growth of isolates in liquid media, only compounds secreted into the filtrate were analysed. This is because the foliar symptoms of eutypa dieback are caused by compounds secreted by the fungus and transported to the foliage of vines. When analysing cultures grown on solid media, compounds from both the mycelium and growth medium were extracted. However, preliminary research conducted at the United States Department of Agriculture indicated that there was little difference in the composition of acetylenic secondary metabolites when extractions were carried out on either mycelium or culture filtrates (Noreen Mahoney, *pers. com.*, April 2001). Hence, while this may have increased the amount of certain compounds following analysis of solid cultures, it would not be expected to have a significant effect on the diversity or composition of secondary metabolites.

Analysis of secondary metabolite production following growth of isolates on liquid media illustrated that both medium composition and environment influenced the amount and type of secondary metabolites produced. For example, on stationary PDB only two isolates produced detectable amounts of secondary metabolite, whereas 10 did so on the shaken broth. In this instance, metabolite concentrations were considerably higher on the shaken broth than on the stationary. In contrast, seven isolates produced secondary metabolites on stationary MYB, and ten isolates on shaken MYB, with higher concentrations on the stationary broth. Differences in secondary metabolite production between isolates grown in shaken and stationary conditions on the same medium suggest that oxygenation did influence both the amount and type of secondary metabolite production. However, there was no consistent correlation between amount and type of secondary metabolite production and the oxygen status of cultures.

A search of the literature revealed that very few studies have examined the effects of agitation on secondary metabolite production. The majority of studies have used either shaken conditions (Evidente *et al.*, 1993; Herrmann *et al.*, 1996; Strasser *et al.*, 2000), stationary conditions (Li *et al.*, 1998; Wedge *et al.*, 1999), or did not state the conditions (Ghisalberti and Rowland, 1993; Dubin *et al.*, 2000). Only two publications were found in which fungi were cultured on the same medium (glucose 2%, oatmeal 2%, degreased soy meal 2%, deionised water) in both stationary and shaken conditions (Bode *et al.*, 2000b, 2000a). These researchers grew *Sphaeropsidales* sp. on shaken and stationary liquid media and observed considerable differences in the amount and type of secondary metabolites produced. By manipulating culture composition and environment, 15 different secondary metabolites were detected, although prior to this research it was believed that *Sphaeropsidales* sp. produced only one major secondary metabolite. When culturing the fungus on shaken malt/yeast extract medium only two secondary metabolites were detected. However, on the same medium maintained in static conditions five compounds were detected, four of which were not present in the shaken broth. Similarly, a variety of studies have shown that fungal secondary metabolite production is strongly influenced by the nutrient status of the growth medium (Luz *et al.*, 1990; Ghisalberti and Rowland, 1993; Herrmann *et al.*, 1996; Li *et al.*, 1998; Aldred *et al.*, 1999; Strasser *et al.*, 2000). These observations are in accordance with the results obtained in the current study.

Analysis of the toxicity of secondary metabolites extracted from all 11 isolates indicated that the majority did contain materials toxic to grapevine leaf discs. However, no correlation was evident between the phytotoxicity of extracts and either the amount or type of acetylenic secondary metabolites. For example, isolate E1 produced six acetylenic phenol compounds following growth for 24 days in shaken Vogel's medium, in amounts between 250 and 1300 mAU, whereas isolate E178 did not produce any detectable secondary metabolites. However, filtrates from both isolates exhibited similar phytotoxicity towards grapevine leaf discs. Control leaf discs treated with methanol did not develop necrosis. Although the amount of standard compounds used as positive controls was not quantified, they were of the same order of magnitude as the experimental samples. However, these compounds were less phytotoxic than purified culture filtrates from *E. lata*. These observations imply that the results are not an artefact of the experiment, but instead suggest that non-phenolic compounds, which were not visualised by HPLC detection at 254 nm, were present in the extracts. This suggests that acetylenic phenol secondary metabolites are not solely responsible for the foliar symptoms of eutypa dieback, as has previously been believed and, furthermore, indicates that there may be compounds which are ubiquitous to *E. lata*, that contribute to the foliar symptoms of the disease. Further research is required to separate and identify these compounds, and this may lead to the isolation of a characteristic chemical marker specific to *E. lata*. When interpreting results from the leaf disc assays, it should be taken into account that metabolites were applied directly to the leaf surface, rather than transported through the xylem, as is the case *in planta*. This method of application may induce a response that differs from that which occurs in nature. However, the technique was expected to provide an indication of the relative toxicity of culture filtrates.

The isolates analysed here were selected in the belief that all 11 were *E. lata*. However, as discussed in Chapters 3 and 4, isolates E178 and SS1#1 are now believed to belong to species other than *E. lata*. Isolate E178 did not produce any compounds which have previously been detected in *E. lata* either in this study, or in that of Molyneux *et al.* (2002). In contrast, isolate SS1#1 did produce eutypinol and siccayne on shaken PDB. However, it should be noted that siccayne is also produced by other fungal species (Ishibashi *et al.*, 1968; Kupka *et al.*, 1981), and the results presented here suggest that eutypinol is not unique to *E. lata*. Isolate M335, which has been verified as *E. lata* using the SCAR markers and RFLP probes developed in this study (Chapters 3 and 4),

showed limited secondary metabolite production, and all compounds produced were unique to this isolate. However, culture filtrates from these three isolates exhibited phytotoxicity towards grapevine leaf discs that was similar to that caused by all other isolates.

Neighbour joining analysis of secondary metabolite data was conducted in order to determine whether there was any relationship between secondary metabolite profiles and either host species or geographic origin of isolates. However, no such correlations were observed, and the majority of groupings were not strongly supported by bootstrap analysis. It was interesting to note that on the basis of this analysis isolate M335 was more distantly related to the remaining isolates of *E. lata* than was isolate SS1#1. However, given that isolate M335 did not produce any compounds in common with other isolates, but isolate SS1#1 did produce both siccayne and eulatinol, this result is not entirely surprising. Another aim of the neighbour joining analysis was to determine whether there was any correlation between secondary metabolite profiles and either RAPD or RFLP banding patterns. However, comparisons with the neighbour joining trees generated in Chapters 3 and 4 revealed no such correlations.

Because there are no specialist packages available for phylogenetic analysis of biochemical data, the TREECON package (Van de Peer and De Wachter, 1994), designed for analysis of molecular data, was used here. Because there is no information regarding the independence of characters or evolutionary relationships between isolates, data were analysed using distance methods. Little is known about the biosynthetic pathways of metabolites detected in this study and, hence, the independence of production of different metabolites. For example, eulatinol and siccayne are structurally related quinols, and it is expected that eulatinol would be produced biosynthetically by the methylation of siccayne (Mahoney *et al.*, 2003), hence, the production of eulatinol would not be expected to be an independent character. However, following growth on stationary MYB, for example, eulatinol was produced by four isolates although none of these isolates produced siccayne on this medium. This implies that these two compounds may be produced independently. Consequently, the algorithm of Nei and Li (1979) was selected to calculate distances between isolates, because this algorithm makes few assumptions about the independence of characters (Felsenstein, 1995).



---

Because no chemical compounds detected here were produced by all *E. lata* isolates, the isolates were subsequently grown on media derived from grapevine cane, in order to determine whether growth on media which more closely approximate natural conditions influences secondary metabolite production.

---

## Chapter 7 Production of secondary metabolites by *E. lata* on grapevine cane extracts

---

### 7.1 Introduction

One of the major aims of the work described in Chapter 6 was to isolate and identify a compound which was produced by all isolates of *E. lata* that would be suitable for use in a diagnostic test to detect the early stages of the disease. However, although a diverse range of compounds was produced, none of these compounds were produced by all isolates of the pathogen. As previously reported (Luz *et al.*, 1990; Ghisalberti and Rowland, 1993; Herrmann *et al.*, 1996; Li *et al.*, 1998; Aldred *et al.*, 1999; Bode *et al.*, 2000b, 2000a; Strasser *et al.*, 2000) and observed in the current study (see Chapter 6), culture medium and environment influence secondary metabolite production. Because of the diversity of secondary metabolite production observed after growth of isolates on artificial media, the same 11 isolates were grown here on substrates derived from canes of Cabernet Sauvignon, a cultivar known to be susceptible to eutypa dieback (Carter, 1991). It was expected that this would more accurately approximate the nutrient conditions to which the fungus is naturally exposed and, hence, have the potential to provide a better indication of phenolic secondary metabolite production by *E. lata in planta*. This work was conducted in the laboratory of Dr Russell Molyneux.

### 7.2 Methods

The 11 isolates analysed for secondary metabolite production on artificial media were grown on a range of media derived from 1-year-old canes of Cabernet Sauvignon.

#### 7.2.1 Fungal growth media

Growth media were derived from 1-year-old canes of Cabernet Sauvignon obtained from a vineyard in California and harvested in late autumn. Canes were ground in a Wiley mill with a 1 mm screen. Six different media were used: ground grapevine cane, consisting of 10 g ground grapevine cane with 50 ml dd H<sub>2</sub>O; ground grapevine cane supplemented with sucrose (1 g sucrose per 10 g cane); 50 ml liquid grapevine cane extract; 50 ml liquid grapevine cane extract supplemented with sucrose (1 g per 50 ml extract); 25 ml of liquid grapevine cane extract solidified with agar (15 g/l; Difco, USA) and 25 ml of liquid grapevine cane extract supplemented with sucrose (0.5 g per 25 ml) and solidified with agar. Liquid cane extracts were prepared by sonicating 200 g of ground cane with 1,000 ml boiling RO water then clarifying the extract by filtration.

Full details of composition and preparation of media are given in Appendix B. All media were sterilised by autoclaving.

Cultures in ground grapevine cane and liquid grapevine cane extracts were grown in 250 ml conical flasks, following inoculation with five to eight plugs (approximately 2 mm<sup>2</sup>) excised from the margins of actively growing colonies on PDA. Cultures grown on agar-solidified media were initiated by placing an agar plug (approximately 4 mm<sup>2</sup>) in the centre of each 90 mm diameter Petri dish. All cultures were maintained in the dark at 25°C for 30 days in stationary conditions. In addition, secondary metabolites from cultures maintained on ground wood, with and without the addition of sucrose, were analysed after 20 days.

## **7.2.2 Isolation of metabolites**

### **7.2.2.1 Ground grapevine cane with water**

Cultures were mixed with 100 ml water, and the mycelium broken up using a spatula. Samples were sonicated for 15-30 s and filtered through Whatman no. 4 filter paper. The filtered extract was partitioned with an equal volume of chloroform, and the aqueous phase discarded. The organic phase was partitioned with an equal volume of water, the aqueous phase discarded and chloroform was removed under reduced pressure. The residue was suspended in 15 ml acetonitrile and liquid was removed under reduced pressure. Residues were dissolved in 1 ml of methanol, filtered through a 0.45 µm 13 mm syringe filter (Gelman, USA) and analysed by HPLC as outlined in section 6.2.4.

### **7.2.2.2 Liquid grapevine cane extract**

Cultures grown in liquid grapevine cane extracts were prepared for HPLC analysis using the technique described in section 6.2.3.1.

### **7.2.2.3 Grapevine cane extract agar**

Cultures grown in agar-solidified grapevine cane extracts were prepared for HPLC analysis using the technique described in section 6.2.3.3.

## **7.2.3 Toxicity of secondary metabolites towards grapevine leaf discs**

The toxicity of secondary metabolite extracts produced by each of the 11 isolates grown for 20 days on ground grapevine cane with and without the addition of sucrose was assessed using the technique described in section 6.2.5. An additional control,

consisting of uninoculated grapevine cane material, which had been subjected to extraction as in section 7.2.2.1 was included to test whether compounds extracted from uninoculated grapevine material were toxic to leaf discs.

#### 7.2.4 Data analysis

Following growth on all grapevine cane extract media, each secondary metabolite was scored as being either present (1) or absent (0) for all isolates, to form a binomial representation of secondary metabolite profiles, and data were analysed using the methods outlined in section 6.2.6. In addition, data obtained following growth of isolates on grapevine extracts and artificial media were combined and analysed using the same techniques.

### 7.3 Results

Following the growth of the 11 isolates on all culture media, 29 different secondary metabolites were produced in quantities greater than 200 mAU. These included eutypinol, siccayne, eulatachromene, eulatinol and eutypine, all of which have previously been detected in culture filtrates of *E. lata*. Benzofuran was not produced by any isolate on media derived from grapevine extracts. The remaining 25 compounds were identified on the basis of retention time only. No single compound was produced by all isolates, although eutypinol was produced by nine isolates (all except M335 and SS1#1) and eutypine by eight (all except E178, M335 and SS1#1). An unidentified compound, Rt 19.6, was produced by the same eight isolates which produced eutypine. Another unidentified compound (Rt 14.0) was produced by seven isolates (E1, E120, E125, M266, M280, N04 and SS6) and one compound (Rt 16.0) was produced by six isolates (E120, E125, M266, M279, M280 and SS6). Seventeen compounds were produced on a single medium only, and nine of these compounds were produced by a single isolate only, although not by the same isolate in each case. The presence or absence of metabolites for each isolate/medium combination is shown in Table 7.1. It is evident that the addition of sucrose to the culture media strongly influenced secondary metabolite production, resulting in an increase in both the amount and variety of secondary metabolites produced. Representative chromatograms are presented in this section, the remainder, showing HPLC profiles of each isolate on all media are given in appendix D. Details of secondary metabolite production by individual isolates on all media are given below.

**Table 7.1** Secondary metabolite profiles of 11 *E. lata* isolates grown on media derived from Cabernet Sauvignon cane, with and without the addition of sucrose, for 20 or 30 days at 25°C in the dark in stationary culture. Production of secondary metabolites on different media, as detected by HPLC, is indicated by “+”, absence is indicated by “-”

Medium/ Metabolite (Rt)	Presence/absence of metabolites for fungal isolate/source										
	E1	E120	E125	E178	M266	M279	M280	M335	NO4	SS1#1	SS6
	Australia Apricot	California Grape	Italy Grape	California Oak	France Grape	Australia Apricot	Australia Grape	Australia Grape	Australia Grape	NZ Grape	Australia Grape
<b>Ground cane (no sucrose, 20 days)</b>											
16.5 (eutypinol)	-	+	+	-	+	-	+	-	-	-	-
18.3	-	-	-	-	-	-	-	+	-	-	-
<b>Ground cane (sucrose, 20 days)</b>											
12.0	-	+	-	-	-	-	-	-	-	-	-
13.4	-	-	-	+	-	-	-	-	-	-	-
13.5	-	+	-	-	-	-	-	-	-	-	-
14.2	-	+	+	-	+	-	+	-	-	-	-
15.4	-	-	-	-	-	-	-	+	-	-	-
16.2	-	+	+	-	+	-	+	-	-	-	+
16.5 (eutypinol)	-	+	+	+	+	-	+	-	-	-	+
19.6	-	-	-	-	-	-	-	-	+	-	-
19.9 (eutypine)	-	+	-	-	-	+	+	-	+	-	-
20.2	-	-	-	-	+	-	+	-	-	-	-
23.1	-	-	+	-	-	-	-	-	-	-	-
24.7	-	-	-	-	-	+	-	+	+	-	-
25.5	-	-	-	-	-	-	-	+	+	-	-

Presence/absence of metabolites for fungal isolate/source											
Medium/ Metabolite (Rt)	E1 Australia Apricot	E120 California Grape	E125 Italy Grape	E178 California Oak	M266 France Grape	M279 Australia Apricot	M280 Australia Grape	M335 Australia Grape	NO4 Australia Grape	SS1#1 NZ Grape	SS6 Australia Grape
<b>Ground cane (no sucrose, 30 days)</b>											
16.5 (eutypinol)	-	+	-	+	-	-	-	-	-	-	-
18.3	-	-	-	-	-	-	-	-	-	+	-
27.8	-	-	+	-	-	-	-	-	+	-	-
	-	-	-	-	-	-	-	-	-	-	-
<b>Ground cane (sucrose, 30 days)</b>											
14.0	-	-	-	-	-	-	-	-	+	-	-
16.0	-	-	+	-	-	-	-	-	-	-	-
16.4 (eutypinol)	+	+	+	-	+	-	+	-	+	-	-
19.6	+	-	+	-	-	-	+	-	+	-	-
19.8 (eutypine)	-	+	-	-	-	-	-	-	-	-	-
22.9	-	-	+	-	-	-	-	-	-	-	-
<b>Liquid cane extract (no sucrose, 30 days)</b>											
16.5 (eutypinol)	+	-	-	-	-	-	-	-	+	-	-
19.6	+	-	-	-	-	-	-	-	+	-	-
22.9	-	-	+	-	-	-	-	-	+	-	-
27.8	-	-	-	+	-	-	-	-	-	-	-



Presence/absence of metabolites for fungal isolate/source											
Medium/ Metabolite (Rt)	E1 Australia Apricot	E120 California Grape	E125 Italy Grape	E178 California Oak	M266 France Grape	M279 Australia Apricot	M280 Australia Grape	M335 Australia Grape	NO4 Australia Grape	SS1#1 NZ Grape	SS6 Australia Grape
<b>Cane extract agar (sucrose, 30 days)</b>											
14.0	-	+	-	-	-	-	+	-	+	-	+
16.5 (eutypinol)	+	+	+	-	+	+	+	-	+	-	+
18.3	-	-	-	-	-	-	-	-	-	-	+
19.6	+	+	+	-	-	+	+	-	+	-	+
20.3 (eulatinol)	-	-	-	-	-	+	-	-	-	-	-
20.8	-	-	-	-	+	-	-	-	-	-	-
22.8	-	-	+	-	-	-	-	-	-	-	-
25.1	-	-	-	-	-	+	-	-	-	-	-



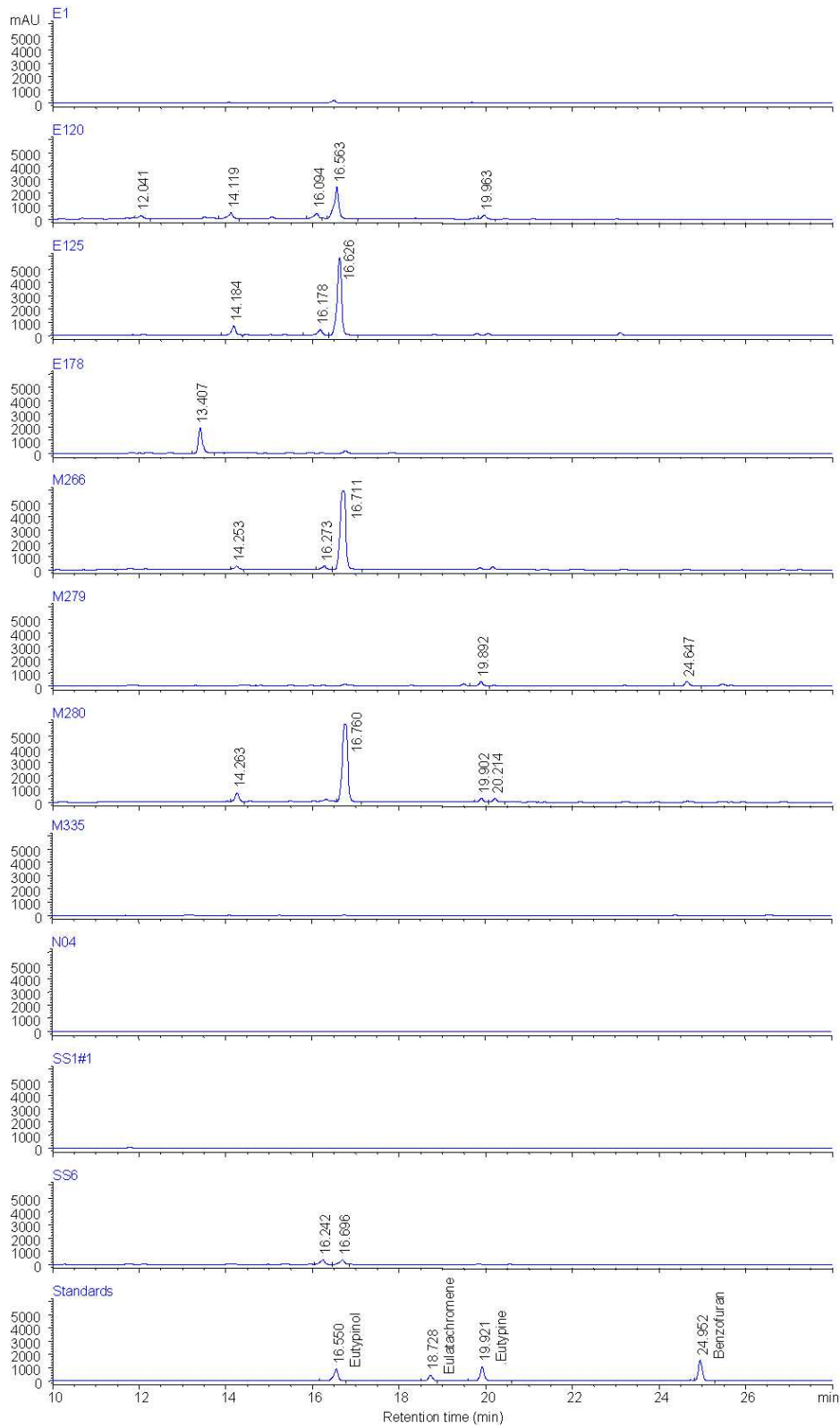
### **7.3.1 Ground grapevine cane with water**

#### **7.3.1.1 Ground grapevine cane (20 days)**

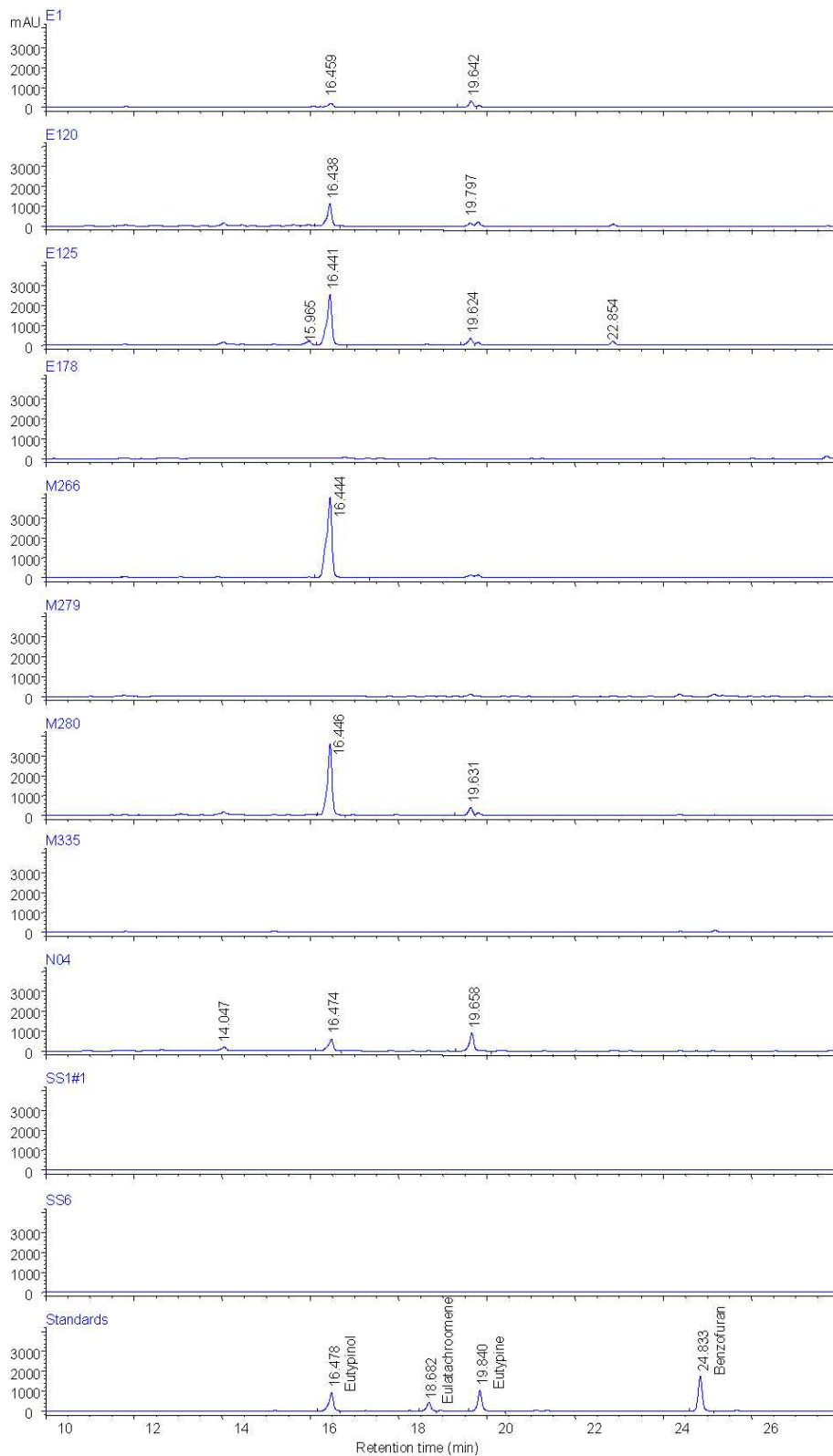
Five isolates produced phenolic secondary metabolites following incubation for 20 days on ground grapevine cane without sucrose. Four isolates (E120, E125, M266 and M280) produced eutypinol (Rt 16.5) in amounts ranging between 550 and 880 mAU, and the remaining isolate (SS6) produced an unidentified compound (Rt 18.3, 650 mAU). On the same medium amended with sucrose, seven isolates produced a total of eight different secondary metabolites (Figure 7.1). Four of these compounds were produced by single isolates only. Eutypinol was produced by five isolates (E120, E125, M266, M280 and SS6) at amounts of up to 6,000 mAU. Eutypine was produced by three isolates (E120, M279 and M280) at amounts of up to 530 mAU. Isolate E178 produced an unidentified compound (Rt 13.4, 1,900 mAU), however, all other compounds were present in amounts lower than 500 mAU.

#### **7.3.1.2 Ground grapevine cane (30 days)**

Five isolates produced phenolic secondary metabolites following growth for 30 days on ground grapevine cane not amended with sucrose. Isolates E120 and M266 both produced eutypinol, and isolate SS6 produced a single compound (Rt 18.3). Isolates E178 and SS1#1 each produced a single compound (Rt 27.8). On ground grapevine cane amended with sucrose, six isolates (E1, E120, E125, M266, M280 and N04) produced five different compounds between them (Figure 7.2). These included eutypinol, produced by all six isolates in amounts ranging between 650-4,000 mAU. An unidentified compound (Rt 19.6) was produced by four isolates in amounts between 200 and 1,000 mAU. The four remaining compounds were produced by single isolates only.



**Figure 7.1** HPLC chromatograms showing secondary metabolite production of 11 isolates of *E. lata* following 20 days growth on ground grapevine cane amended with sucrose.



**Figure 7.2** HPLC chromatograms showing secondary metabolite production of 11 isolates of *E. lata* following 30 days growth on ground grapevine cane amended with sucrose.

### 7.3.2 Liquid cane extract (30 days)

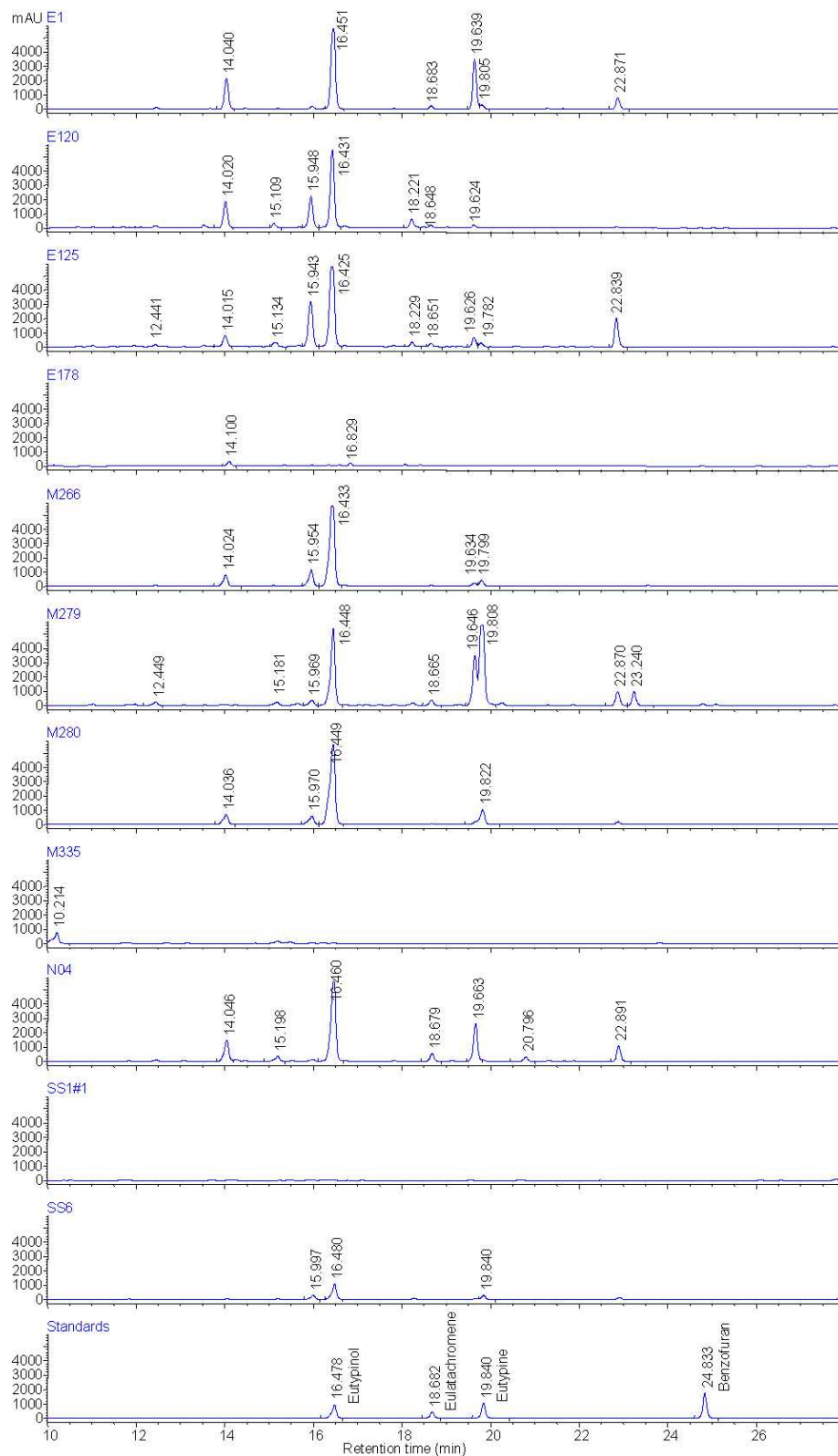
Four isolates produced four different compounds on liquid cane extract which was not amended with sucrose. These included eutypinol (E1 and N04) and three unidentified compounds with retention times of 19.6 min (E1 and N04), 22.9 min (E125 and N04) and 27.8 min (E178), respectively. Following incubation for 30 days on the same medium amended with sucrose, ten isolates produced 15 phenolic secondary metabolites between them (Figure 7.3). The only isolate which did not produce any secondary metabolites was SS1#1. The predominant compound was eutypinol, produced by eight isolates (E1, E120, E125, M266, M279, M280, N04 and SS6) in amounts ranging between 1000 and 6000 mAU. Eutypine was produced by six isolates (E1, E125, M266, M270, M280 and SS6) in amounts ranging between 280 and 4900 mAU. Eulatachromene was produced by isolates E1, E120, E125, M279 and N04, and siccayne was produced by isolate E178. Three unidentified compounds (Rt 19.6, Rt 14.0, Rt 16.0) were also produced by six isolates, however, the same isolates did not produce all three compounds. Two compounds (Rt 15.1 and Rt 22.9) were produced by four isolates. All other compounds were produced by either one or two isolates.

### 7.3.3 Grapevine extract agar (30 days)

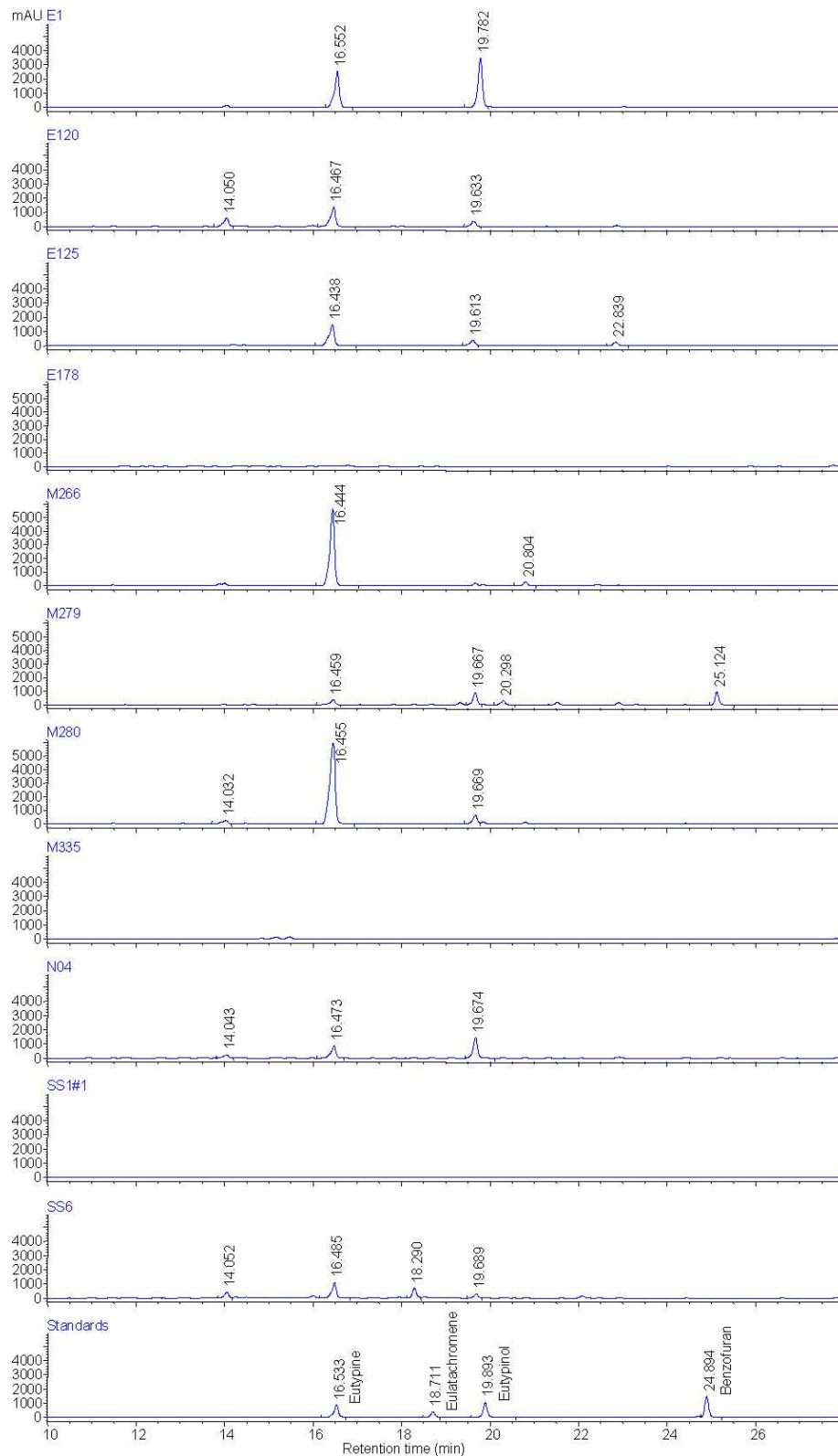
One isolate (SS6) produced a single compound (Rt 22.0) following growth on grapevine extract agar not amended with sucrose (data not shown). On the same medium amended with sucrose, eight isolates (E1, E120, E125, M266, M279, M280, N04 and SS6) produced eight phenolic secondary metabolites between them (Figure 7.4). These included eutypinol, produced by these eight isolates and an unidentified compound (Rt 19.6), which was produced by seven of the same eight isolates (all except M266). One compound (Rt 14.0) was produced by four isolates, all others were produced by single isolates only. It should be noted that due to fluctuations in the laboratory temperature during HPLC analysis of isolates following growth on grapevine extract agar there was some variation in retention times between isolates. For example, isolate E1 produced two compounds with retention times of 16.5 and 19.7 min, respectively, whereas all other isolates which produced secondary metabolites on this medium produced two compounds with retention times of 16.4 and 19.6 min, respectively. Hence, it was considered that the compounds produced by isolate E1 were in fact the same as the compounds produced by the other isolates, and differences in retention time were caused by changes in the temperature of the column during the analysis.

### **7.3.4 Toxicity of secondary metabolites towards grapevine leaf discs**

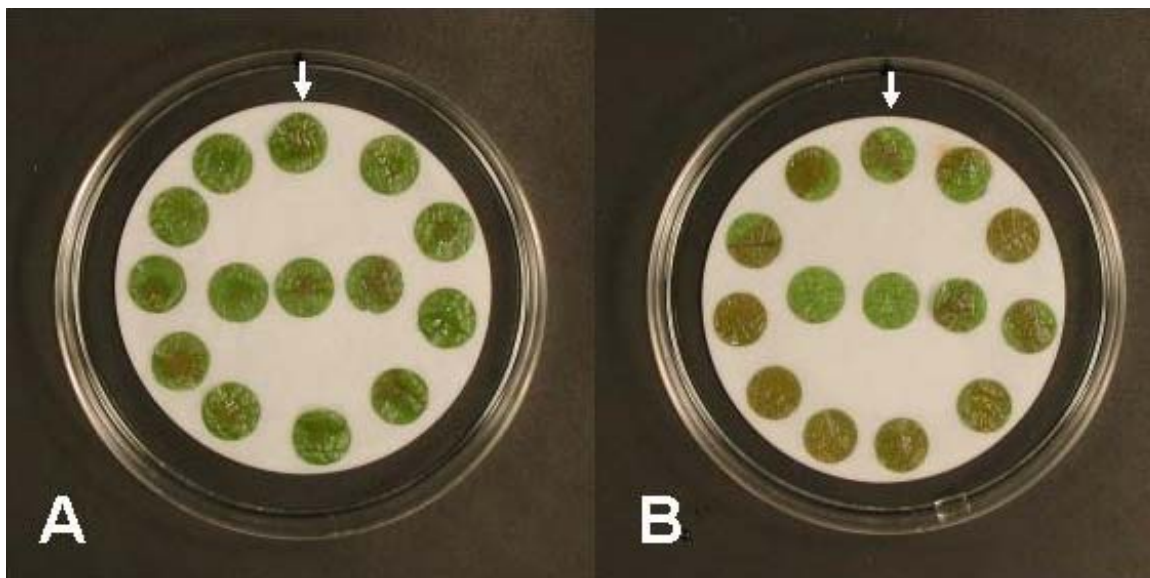
The phytotoxicity of total secondary metabolite extracts from all isolates grown on ground grapevine cane with and without sucrose was assessed following 20 days growth. Extracts from six isolates (E1, E125, M266, M280, M335 and N04) were toxic towards leaf discs following growth on ground grapevine cane without sucrose (Figure 7.5). The extract from uninoculated grapevine cane showed no toxicity towards leaf discs. However, both the methanol-treated control disc (negative control) and the disc treated with the mixture of four characterised secondary metabolites from *E. lata* (positive control) developed a clearly defined area of necrosis (Figure 7.5). Following growth on the same medium amended with sucrose, extracts from all 11 isolates exhibited marked toxicity towards grapevine leaf discs, although neither the grapevine extract nor methanol controls exhibited phytotoxicity (Figure 7.5). Discs treated with the mixture of four standard compounds developed a clearly defined area of necrosis.



**Figure 7.3** HPLC chromatograms showing secondary metabolite production of 11 isolates of *E. lata* following 30 days growth on liquid grapevine cane extract amended with sucrose.



**Figure 7.4** HPLC chromatograms showing secondary metabolite production of 11 isolates of *E. lata* following 30 days growth on liquid grapevine cane extract agar amended with sucrose.



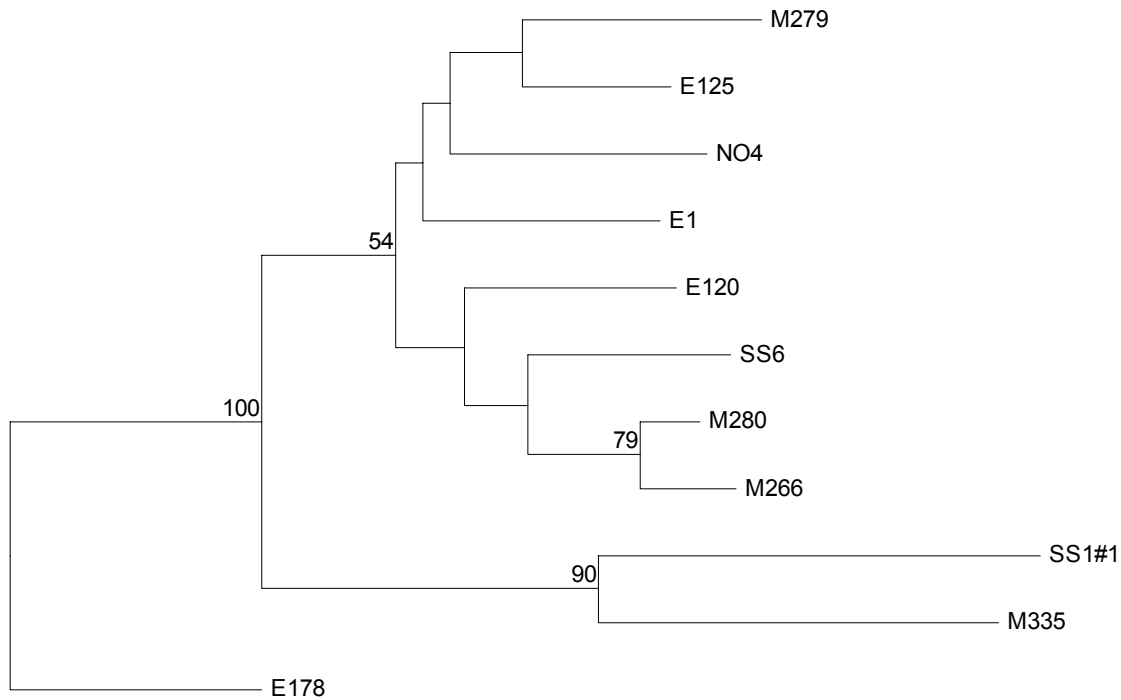
**Figure 7.5** Phytotoxicity of culture filtrates from 11 isolates of *E. lata*, grown on ground grapevine cane for 20 days, towards leaf discs excised from Cabernet Sauvignon grapevines grown in the glasshouse. Culture filtrate of the test isolate was applied to the disc as follows (clockwise from the top centre disc, marked with an arrow, on each Petri dish): E1, E120, E125, E178, M266, M279, M280, M335, N04, SS1#1, SS6. A, grapevine cane, no sucrose; B, grapevine cane amended with sucrose. In the centre of each Petri dish are (left) extract from uninoculated grapevine cane; (centre) methanol control and (right) a mixture of *E. lata* metabolites eutypinol, eulatachromene, eutypine and benzofuran. Photographs were taken 48 h after application of filtrates.

### 7.3.5 Data analysis

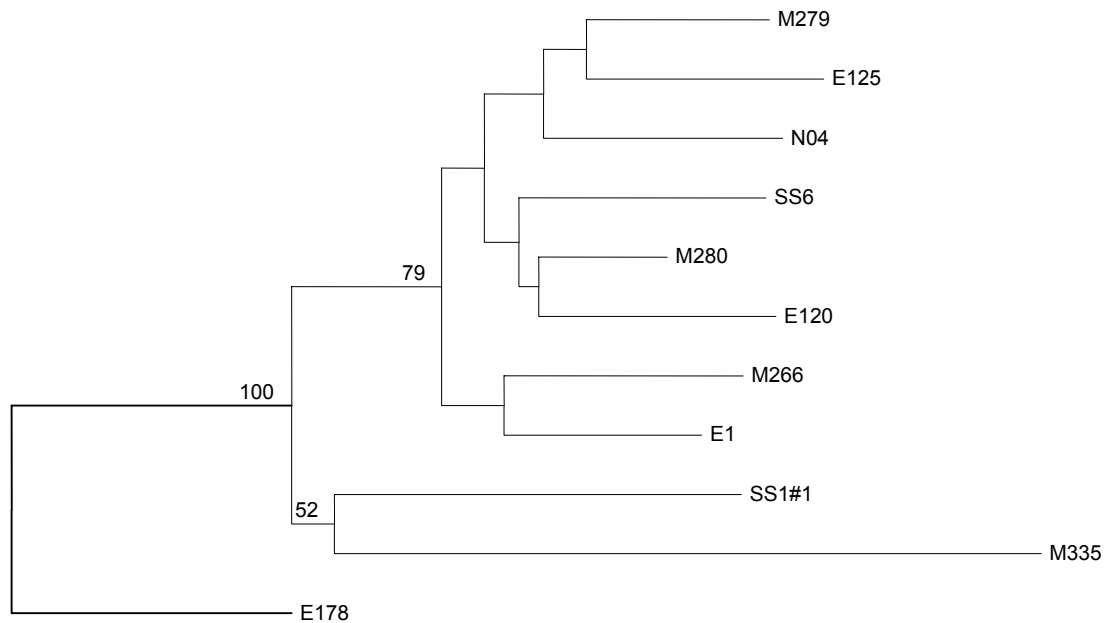
Neighbour joining analysis of secondary metabolite production following growth of isolates on all media derived from grapevine cane placed isolate M335 in a group apart from all other isolates of *E. lata*. This isolate was grouped with isolate SS1#1, a grouping strongly supported by bootstrap analysis (Figure 7.6). The remaining isolates were placed in a single group, supported by a bootstrap value of 54%. With the exception of isolates M266 and M280, no other groupings were supported by bootstrap values of over 50% (Figure 7.6).

The phylogenetic tree constructed following neighbour joining analysis of combined data obtained following growth of isolates on all artificial and grapevine cane media is given in Figure 7.7. Isolates M335 and SS1#1 were placed in a single group, distinct from all other isolates of *E. lata*. This grouping was strongly supported by bootstrap analysis. The remaining eight isolates of *E. lata* were placed in a single group, supported by a bootstrap value of 79%. Within this group no pairings of isolates were supported by bootstrap values of greater than 50%. For all analyses, isolate E178 was defined as the outgroup.





**Figure 7.6** Neighbour joining tree generated using TREECON (Van de Peer and De Wachter, 1994), calculated using presence/absence data of secondary metabolites from 11 isolates following growth on all grapevine extract media. Isolate E178 was specified as the outgroup. Distances were calculated using the algorithm of Nei and Li (1979). Bootstrap values greater than 50% are given.



**Figure 7.7** Neighbour joining tree generated using TREECON (Van de Peer and De Wachter, 1994), calculated using presence/absence data of secondary metabolites from 11 isolates of *E. lata* following growth on all artificial and grapevine extract media. Isolate E178 was specified as the outgroup. Distances were calculated using the algorithm of Nei and Li (1979). Bootstrap values greater than 50% are given.

## 7.4 Discussion

A total of 29 different phenolic secondary metabolites was produced following growth of the 11 isolates on all media derived from grapevine cane. Although the spectrum of metabolites varied with the medium, the majority of compounds were present in small amounts, with eutypinol being the major secondary metabolite in many instances. Also present in considerable amounts, in particular following incubation of isolates on ground cane and liquid grapevine cane extracts amended with sucrose, were eulatachromene, eutypine and the unidentified compound, Rt 19.6. It has been suggested that this unidentified compound may be an O-methyl derivative of either eutypinol or siccayne, based on the similarities in UV spectra to these compounds (Mahoney *et al.*, 2003). Research is currently being conducted in California to identify and characterise this compound. Although certain isolates produced considerable amounts of some unidentified compounds, these were not produced by the majority of isolates and, hence, it is unlikely that they would be of value as characteristic chemical markers.

Both eutypine and the unidentified compound with Rt 19.6 were produced by all confirmed isolates of *E. lata*, apart from isolate M335, but not by the non-*E. lata* isolates E178 or SS1#1. Isolate M335 did not produce any compounds which have previously been identified in *E. lata* and, following growth on all grapevine extract media, it produced only five secondary metabolites, all in amounts of less than 750 mAU. Only two of these compounds were produced by other isolates (either M279 or N04).

Isolate M335 was confirmed as *E. lata* on the basis of molecular analyses (see Chapters 3 and 4). However, given these results, and similar results obtained following growth on artificial media (see Chapter 6), it seems likely that isolate M335 lacks the ability to produce certain secondary metabolites. Fungi may lose pathogenicity following repeated sub-culturing or prolonged storage of isolates (Zuckerman *et al.*, 1989; Gramss, 1991; Krokene and Solheim, 2001). A loss of ability to produce certain secondary metabolites has been noted for *Penicillium expansum* (Santos *et al.*, 2002). Santos *et al.* (2002) reported that production of the secondary metabolite patulin was inconsistent following storage of isolates, however, citrinin, another secondary metabolite produced by the same species, was consistently detected following storage. It is believed that the response of fungi to preservation may be isolate-specific (Ryan *et*

*al.*, 2001; Santos *et al.*, 2002), hence, it is possible that isolate M335 may have lost the ability to produce certain secondary metabolites, for example eutypine or eutypinol. This isolate was obtained from perithecia on dead grapevine wood in 1999, at the same time as isolate M280, which could produce eutypine and eutypinol. Both isolates were stored in RO water at 4°C.

As noted in previous chapters, only nine of the 11 isolates are now considered to be *E. lata*. Whilst eutypinol was produced by eight isolates of *E. lata*, it was also produced by isolates E178 and SS1#1, both of which also produced siccayne. Isolate E178, now believed to be either another species of *Eutypa*, or to belong to another genus, produced eutypinol following growth on ground grapevine cane, and siccayne following growth on liquid grapevine cane extracts. Isolate SS1#1, now believed to be *Cryptovalsa ampelina*, did not produce any compounds in common with *E. lata* following growth on grapevine cane extracts. However, eutypinol and siccayne were present following growth of this isolate on shaken PDB (see Chapter 6).

The observation that these non-*E. lata* isolates are capable of producing compounds in common with *E. lata* in culture has implications for the development of a diagnostic test for eutypa dieback based upon the detection of chemical markers in the foliage of infected vines. Although there are no previous reports of analysis of secondary metabolite production by *C. ampelina*, analysis of secondary metabolite production by the following fungi inhabiting grapevine wood has been reported: *Stereum hirsutum* (Dubin *et al.*, 2000; Tabacchi *et al.*, 2000), *Phaeoacremonium aleophilum* (Evidente *et al.*, 2000; Sparapano *et al.*, 2000; Tabacchi *et al.*, 2000), *Phaeomoniella chlamydosporum* (Sparapano *et al.*, 2000; Tabacchi *et al.*, 2000) and *Fomitiporia punctata* (Sparapano *et al.*, 2000; Tabacchi *et al.*, 2000). Although none of these species has produced any secondary metabolites in common with *E. lata*, they do produce related compounds. Therefore, if a chemical marker ubiquitous to *E. lata* is found, a range of other grapevine inhabiting fungi would need to be screened following growth on various media to determine whether they have the potential to produce putative *E. lata*-specific chemical markers.

It has previously been demonstrated that *E. lata* grows well in wood extracts with a high content of nitrogen and carbohydrates (Ferreira, 1999). Although the growth rate of isolates was not assessed in the current study, secondary metabolite production of all *E.*

*lata* isolates, with the exception of M335, was enhanced by the addition of sucrose. Additional research could be conducted to determine the influence of sucrose concentration and the effects of other sugars, especially those from grapevine wood, on secondary metabolite production. Although the effect of nitrogen content on secondary metabolite production was not analysed in this study, future research could be conducted to determine whether this also influences the amount or range of secondary metabolites produced.

Analysis of secondary metabolite production of all isolates grown on ground grapevine cane was conducted after incubation for 20 and 30 days. Considerable differences were apparent for individual isolates grown for each time period. Phenolic secondary metabolite production was more diverse and compounds were generally produced in larger amounts when cultures were harvested at 20 days. Although the effects of time on secondary metabolite production have been analysed following growth of *E. lata* on artificial media (Molyneux *et al.*, 2002), this was not analysed in detail in the current study. However, the observation that there are significant differences in secondary metabolite production depending upon the period of incubation implies that the effect of culture maturity needs to be taken into account when assessing the suitability of compounds for use as characteristic chemical markers. In particular, once a suitable compound has been identified, the time course of production of this compound would need to be assessed in infected grapevines in order to determine whether it is produced in all stages of infection or only at certain times. This point is highlighted by the fact that thin layer chromatographic analysis of secondary metabolites of *E. lata* in asymptomatic grapevine cuttings inoculated with mycelium of *E. lata* by Dr Mette Creaser did not reveal the presence of eutypine. However, numerous other compounds were detected, none of which were present in uninoculated cuttings (T. Wiechel, *pers. com.*, July 2002). Similarly, HPLC analysis of extracts from a grapevine exhibiting foliar symptoms following inoculation with mycelium from *E. lata* isolate M280 did not show the presence of eutypine, although other, unidentified compounds were detected (T. Wiechel, *pers. com.*). Given that isolate M280 produced small amounts of eutypine following growth for 20 days on ground grapevine wood amended with sucrose but no eutypine was detected after 30 days (see Figures 7.1 and 7.2), it is possible that certain compounds may be produced for limited periods and, hence, may not be suitable for use as a characteristic chemical marker.

Analysis of the phytotoxicity of culture filtrates from all 11 isolates grown on Cabernet Sauvignon wood with and without the addition of sucrose indicated that extracts from isolate M335 were as phytotoxic as those of any other isolates, despite the fact that this isolate exhibited very low secondary metabolite production on these media. Similar results were observed when analysing secondary metabolite extracts following growth on artificial media (Chapter 6). These observations suggest that non-acetylenic compounds may be at least partially responsible for the foliar symptoms of eutypa dieback. Unfortunately, due to the destruction of the material from which leaf discs were obtained, the phytotoxicity of culture filtrates following growth of isolates on other media derived from grapevine was not assessed here. Although extracts from uninoculated grapevine cane were not toxic to leaf discs, HPLC analysis of such extracts revealed that they had an extremely high phenolic content (data not shown). However, following growth of *E. lata* on cane extracts, these phenolic compounds were not detected, suggesting that they may be metabolised by the fungus.

In this study, the toxicity of extracts from uninoculated artificial media towards grapevine leaf discs was not assessed. It has previously been reported that extracts from uninoculated PDB medium may inhibit seedling growth of radish and dogwood (Wedge *et al.*, 1999). Hence, the possibility that foliar symptoms were an artefact of the medium upon which the fungus was grown must be considered. However, control extracts from uninoculated grapevine wood amended with sucrose were not phytotoxic, even though culture filtrates from all isolates were toxic towards leaf discs, regardless of whether or not secondary metabolites were detected. Hence, it seems unlikely that the phytotoxicity was solely due to extracts from the growth medium.

Secondary metabolite extracts from non-*E. lata* isolates E178 and SS1#1 exhibited similar phytotoxicity to all other isolates following growth on grapevine cane amended with sucrose. Isolate E178 was not obtained from grapevine, however, isolate SS1#1, probably *Cryptovalsa*, was isolated from perithecia on mature grapevine wood. *C. ampelina* has been isolated from perithecia on 1-year-old grapevine prunings as well as from older wood (Ferreira, 1988). Although the status of *C. ampelina* as a pathogen of grapevine remains unknown, it appears to be weakly pathogenic to grapevines (Mostert *et al.*, *pers. com.*, July 2003). The observation that phenolic secondary metabolites from this species were toxic towards grapevine leaf discs suggests that the possibility that this species is pathogenic towards grapevine merits further investigation.

Isolate M280 was pathogenic towards micropropagated grapevine plantlets (M. Cole *pers. com.*, February 2003) and grapevine cuttings in the glasshouse (S. John, *pers. com.*, July 2002). However, little is known regarding the pathogenicity of the other isolates. Because it could prove useful to correlate pathogenicity with secondary metabolite production, a grapevine tissue culture collection was established using two micropropagated Cabernet Sauvignon plantlets provided by Dr Tonya Wiechel. Although this is not an ideal method for assessing pathogenicity, some isolates were obtained under a quarantine permit and could be cultured *in vitro* only. Previous research suggested that, depending on the isolate used, foliar symptoms become evident within 5-15 days following inoculation of plantlets from which the third leaf of the plantlet has been excised (Mauro *et al.*, 1988, M. Cole, *pers. com.*). In this study, plantlets were inoculated with mycelial plugs from *E. lata* isolates M280 or E1 following either excision of the third leaf of the plantlet, removal of the shoot tip, or wounding of the petiole on the third leaf. However, inoculation of six plantlets with isolate M280 and 12 with isolate E1 following excision of the third leaf failed to produce symptoms 9 weeks after inoculation, although five of six plantlets inoculated with isolate M280 following removal of the shoot tip did develop leaf necrosis 14 weeks after inoculation. Unfortunately, due to the prolonged incubation period required before symptoms were expressed, the pathogenicity of the remaining ten isolates could not be assessed because of time constraints. Plantlets were freeze-dried either 9 or 14 weeks after inoculation, and extracts from these plantlets will be assessed for the presence of secondary metabolites characteristic of *E. lata* by Dr Russell Molyneux and Noreen Mahoney at the United States Department of Agriculture as part of ongoing collaborative research.

As for the results in Chapter 6, no correlations were observed between secondary metabolite profiles and host species or geographic origin of isolates. Neither was there any correlation between groupings made on the basis of secondary metabolite production and either RAPD or RFLP profiles. Given the considerable differences in secondary metabolite production between isolate M335 and the remaining isolates of *E. lata*, it might have been expected that some differences would be apparent in either the RAPD or RFLP profiles of this isolate. However neighbour joining analysis of these profiles revealed that this was not the case (see Chapters 3 and 4). Comparisons between molecular banding patterns and secondary metabolite profiles have been made for a variety of other fungi. For example, correlations have been noted between

secondary metabolite profiles of *Daldinia* sp. and both minisatellite PCR and 18S rDNA restriction profiles (Stadler *et al.*, 2001). Similarly, positive correlations have been made between secondary metabolite profiles of *Fusarium* sp. (Mulé *et al.*, 1997) and *Aspergillus flavus* (Bayman and Cotty, 1993) following 28S rDNA sequencing and RAPD analysis, respectively. However, other studies failed to reveal any correlation between secondary metabolites and molecular data. For example, comparison of RAPD and secondary metabolite profiles of *Aspergillus flavus* and *A. parasiticus* (Tran-Dinh *et al.*, 1999) failed to reveal any correlation, as did a comparison of PCR-RFLP and secondary metabolite profiles of *Aspergillus* sect. *flavi* (Egel *et al.*, 1994). It should be taken into account that of the 11 isolates analysed here, only nine were *E. lata*, and a greater number of isolates would need to be analysed in order to determine reliably whether any such correlations could be made.

In summary, although eutypinol was produced by eight of the nine isolates of *E. lata* grown in grapevine extract media, it was also produced by two other species and, hence, would not prove suitable as a characteristic diagnostic for *E. lata*. The most promising compounds were either eutypine or the unidentified compound, Rt 19.6. However, only nine isolates of *E. lata* were analysed here, and more isolates would need to be assessed for their ability to produce these compounds prior to the development of a test for either compound. In addition, it appears that the compounds detected by HPLC in this study are not solely responsible for the necrosis of leaf discs, implying that non-phenolic compounds may be partially responsible for foliar symptoms. It is, therefore, possible that non-phenolic compounds may be produced by all isolates of *E. lata*, but not by any other species. Future research should be conducted in order to isolate and identify these compounds and to assess their specificity as chemical markers for *E. lata*.

---

## Chapter 8 General Discussion

---

The SCAR and RFLP markers developed in this study were specific to *E. lata* and could be used to detect the pathogen in infected grapevine cane and wood. RFLP analysis of 38 isolates obtained as *E. lata* revealed significant genetic variation among these isolates. No relationship was apparent between host or geographic origin of isolates and RFLP profiles. RFLP analysis suggested that four isolates which had profiles considerably different from the remaining isolates were not, in fact, *E. lata*. RAPD analysis of a subset of 11 isolates using 10 random primers, likewise, revealed considerable genetic variation. Two of the four isolates which RFLP analysis suggested did not belong to the species *E. lata* were included in RAPD analysis and differed considerably in RAPD profiles from the remaining nine isolates. Phenolic secondary metabolite production of the same 11 isolates, when analysed following growth on a range of media for 20-30 days, was strongly influenced by the medium upon which the isolate was grown. Secondary metabolite profiles were more consistent following growth on grapevine cane extracts, in particular after the addition of sucrose to these extracts. Two secondary metabolites, eutypine and a novel compound with a retention time of 19.6 min, were produced by eight of nine confirmed isolates of *E. lata* after growth in grapevine cane extracts. Either of these compounds may have the potential to be used as a chemical marker in an early diagnostic test for eutypa dieback.

In this study, several fungi isolated from perithecia on mature grapevine wood were initially identified as *E. lata* on the basis of morphology. In addition, two of the 11 isolates provided by collaborators, E178 and SS1#1, which were subjected to molecular and biochemical analyses, were shown to be species other than *E. lata*. These isolates could not be readily distinguished from *E. lata* on the basis of morphology of the anamorph, which confirms reports by other researchers (Glawe *et al.*, 1982; Carter, 1991) and highlights the requirement for a reliable method of identifying the fungus following isolation from grapevine. Both the SCAR and RFLP markers developed here distinguished *E. lata* from *Cryptovalsa* and other morphologically similar fungi isolated from mature grapevine wood. It is recommended that prior to commencing studies on *E. lata*, the identity of the pathogen should be confirmed by the use of SCAR markers. This is less time consuming than the use of Southern probes and does not require the use of radioactive isotopes. In addition, detection may be accomplished by the addition



of a small fragment of mycelium directly to the PCR mixture, without the need for DNA extraction (data not shown).

In contrast to the proposal by DeScenzo *et al.* (1999), that there may be a molecular basis for the separation of the genus *Eutypa* into two groups, analyses of isolates of *E. lata* from France and other European countries have not identified distinct groups of the pathogen on the basis of molecular data (Péros *et al.*, 1996; Péros *et al.*, 1997; Péros and Larignon, 1998; Péros and Berger, 1999). Likewise, RFLP analysis of 38 isolates received as *E. lata* did not provide any evidence for separation of the species in the current study. Hence, while the possibility that other members of the genus *Eutypa* may be pathogenic towards grapevine must not be discounted, it seems likely that the majority of pathogenic isolates in Australia probably do belong to *E. lata*. Of the 38 isolates included in RFLP analysis, 25 originated in Australia, of which 18 were obtained from grapevine. The majority of isolates were obtained from South Australia, mainly around Adelaide. Only five isolates originated in Victoria and one in New South Wales. It is possible that if other species of *Eutypa* are capable of causing dieback of grapevine in Australia they may occur in different climatic regions or in geographic locations other than South Australia. More recently, it has been suggested that another species of *Eutypa*, designated *E. leptoplaca*, which can be distinguished from *E. lata* on the basis of morphological and molecular characteristics, may be pathogenic towards grapevine in California (Trouillas *et al.*, 2002). Similarly, Mostert *et al.* (2001) identified an isolate obtained from grapevine in New South Wales in Australia as a species of *Libertella*, on the basis of morphological evidence. These authors suggested that while this isolate probably did belong to the genus *Eutypa*, it could be distinguished from *E. lata* on the basis of anamorph morphology in culture (Mostert *et al.*, 2001). Hence, to confirm whether or not other species of *Eutypa* infect grapevine in Australia, molecular analyses should be conducted using isolates obtained from grapevine in a wide range of locations.

If isolates of *Eutypa* in Australia could be placed in sub-specific groups, both of which were capable of infecting grapevine, the suitability of the SCAR markers and RFLP clones developed here for identifying these isolates would need to be assessed. If isolate E178 is capable of causing symptoms typical of eutypa dieback in grapevines, the fact that it could not be detected using the markers developed here needs to be taken into account. The pathogenicity of isolate E178, and the other isolates which were

grouped with this isolate by DeScenzo *et al.* (1999), should be tested on grapevine, and the identity of these isolates should be confirmed in order to establish their relationship to *E. lata*.

This is the first study in which the production of phenolic secondary metabolites by *E. lata* was analysed following growth of isolates on media containing grapevine extracts. In addition, a wider range of isolates was analysed here than in previous studies (Tsoupras *et al.*, 1988; Tey Rulh *et al.*, 1991; Molyneux *et al.*, 2002). Grapevine extract media were included in this study to reflect nutrient conditions *in planta*. Given the greater consistency of phenolic secondary metabolite profiles among isolates following growth on grapevine extract media than on artificial media, it is recommended that media derived from grapevine be used for future analysis of metabolite production by *E. lata*.

No single artificial medium appeared universally conducive to the production of eutypine, with different isolates producing this compound on different media. The compound with Rt 19.6 min was produced by only one isolate on a single artificial medium. Both of these compounds were produced on the majority of media derived from grapevine cane. Hence, nutrient conditions obviously have a large influence on whether or not these compounds are produced by *E. lata*, however, little is known about the production of either of these compounds *in planta*. Various unidentified compounds have been detected in inoculated grapevine cuttings prior to the expression of foliar symptoms but not in un-inoculated control plants. However, eutypine was not detected in inoculated plants (T. Wiechel, *pers. com.*). Hence, before a chemical marker is selected, inoculation of these characterised isolates should be conducted on grapevine material to determine which compounds are likely to be produced *in planta*, and at what stages of fungal growth they are present. To obtain more information on the toxicity of culture filtrates, and to assess the potential of various techniques, for example near infra-red reflectance spectroscopy (NIR) or liquid chromatography mass spectrometry (LCMS), for detecting these compounds *in planta*, culture filtrates from these characterised isolates could be injected into grapevine shoots. This would allow monitoring of symptom development and could provide additional information regarding the phytotoxicity of various metabolites. In addition, information could be gathered regarding the amounts of secondary metabolites required to induce foliar symptoms *in planta*.

Results of this study indicate that compounds which could not be visualised by UV detection at 254 nm are also responsible, at least in part, for the foliar symptoms of eutypa dieback. Before the experiments outlined above are conducted, culture filtrates should be subjected to further analysis to determine the identity of those compounds which were not detected by HPLC but were toxic to grapevine leaf discs *in vitro*. Whilst the phenolic compounds detected in the current study are well suited to detection by the use of techniques such as NIR spectroscopy, it is possible that these other compounds, if they are ubiquitous and specific to *E. lata*, could also be detected *in planta*. Even if these compounds could not be readily detected by spectroscopy, other assays, for example immunological tests could be developed.

Symptoms of eutypa dieback are most clearly visible at the start of a growing season. This is partly because symptomatic tissue may become obscured by healthy growth from other parts of the vine later in the growing season. However, symptomatic shoots can recover and display normal growth later in the season. Injection of secondary metabolites into grapevine tissue throughout the growing season could provide an indication of whether older grapevine tissue is less susceptible to these metabolites. If, for example, foliar symptoms could be induced at all times of the year, this would suggest that certain phytotoxic metabolites may be produced by the fungus only at the start of a growing season, perhaps enhanced by the greater carbohydrate content in woody tissue at this time. This hypothesis is supported by the observation that production of phenolic metabolites was enhanced following the addition of sucrose to grapevine extracts. If greater concentrations of secondary metabolites were required to induce foliar symptoms as the season progressed this would suggest that older tissue may be less susceptible to the effects of the phytotoxins. These experiments could be carried out on representative cultivars of grapevine tolerant and susceptible to eutypa dieback. This could provide information on whether the apparent tolerance of certain cultivars to eutypa dieback (Mauro *et al.*, 1988; Tey Rulh *et al.*, 1991; Munkvold and Marois, 1995; Anon, 1997) is due to a reduced susceptibility to the toxins produced by the fungus. If, for example, similar degrees of leaf necrosis were induced on tolerant and susceptible cultivars, this could indicate that the tolerance of some cultivars to eutypa dieback may be due to the inability of *E. lata* to produce toxic metabolites in these cultivars.

The ultimate aim of the biochemical studies was to develop an early diagnostic test for eutypa dieback. There is no requirement for a chemical marker to be phytotoxic. Hence, it is possible that while toxic compounds such as eutypine may not be produced at all times of the year or at all stages of fungal development, other, non-toxic compounds may be produced consistently throughout a growing season. Because of the delay between inoculation and the expression of foliar symptoms and the reluctance of growers to allow the inoculation of healthy vines with *E. lata*, it may be difficult to monitor the production of secondary metabolites by *E. lata* over time. However, this could be assessed by inoculating cuttings or whole vines in a glasshouse or research vineyard with the isolates characterised in this study, and also by monitoring secondary metabolites present in vines already infected with *E. lata*. Taken together, this information could indicate when specific metabolites are likely to be produced by *E. lata in planta*. However, if using naturally infected material in the field, these vines may also be infected by other pathogens. Hence, care would need to be taken when interpreting these results because other pathogens may produce detectable secondary metabolites.

The observation that one isolate of *E. lata* (M335) did not produce any of the major metabolites which were present in the remaining eight isolates of *E. lata* has implications for the development of an early detection system for *E. lata* based on biochemical markers in the foliage of infected vines. This isolate induced necrosis on grapevine leaf discs. Although isolate M335 was obtained from grapevine, it is possible that it may have lost its pathogenicity towards grapevine following storage. The pathogenicity of this isolate should, therefore, be assessed and compared with the pathogenicity of the other isolates. Pathogenicity could be assessed either using micropropagated grapevine plantlets or grapevine cuttings in the glasshouse. If this isolate is pathogenic towards grapevine, the fact that it did not produce any of the characteristic secondary metabolites produced by other isolates of *E. lata* needs to be considered when selecting a chemical marker for the early detection of eutypa dieback. This highlights the need to analyse secondary metabolite production of a greater number of isolates before selecting a suitable chemical marker.

In this instance, the 11 isolates were grown on grapevine cane extracts from a single cultivar (Cabernet Sauvignon), which is susceptible to eutypa dieback. However, future studies could be conducted following growth on a range grapevine cultivars with

varying tolerance to eutypa dieback to determine whether cultivar influences secondary metabolite production. Similarly, isolates could be grown on wood collected during the spring when foliar symptoms of the disease are most pronounced, rather than on wood collected following pruning, which was the case in the current study. This may provide a more accurate estimation of which compounds are produced by *E. lata* at the start of a growing season when foliar symptoms of the disease are most pronounced.

The observation that non-*E. lata* isolates have the potential to produce metabolites in common with *E. lata* also has implications for the development of a biochemical diagnostic test for eutypa dieback. Given that both of the non-*E. lata* isolates analysed here were capable of producing siccayne and eutypinol, it is possible that they may also produce other phenolic metabolites as well as other types of secondary metabolite. Although neither eutypinol and siccayne are toxic towards grapevine leaf discs (Smith *et al.*, 2003), this does not rule out the possibility that these isolates may produce toxic metabolites. Indeed, filtrates from these isolates exhibited phytotoxicity similar to isolates of *E. lata*. Isolate SS1#1 is now considered to be *C. ampelina*, or a related species. The former produces perithecia on one-year-old grapevine cane and on mature grapevine wood (Ferreira and Augustyn, 1989). Because of the similarity of these two organisms in culture, if *C. ampelina* is capable of causing a dieback disease similar to eutypa dieback, it is possible that, when making mycelial isolations, this pathogen could be routinely isolated and misidentified as *E. lata*. If this was the case, then a diagnostic test based upon the detection of chemical markers unique to *E. lata* would not be expected to identify these infections.

Monitoring of ascospores in vineyards of Northern California revealed the presence of ascospores not only of *E. lata*, but also of related diatrypaceous fungi, namely *E. leptoplaca*, *Cryptovalsa*, *Diatrype* and *Diatrypella* species, all of which were similar in morphology to *E. lata* (Trouillas *et al.*, 2001). Preliminary pathogenicity studies indicated that these isolates may be capable of infecting grapevine (Trouillas *et al.*, 2001). On the basis of these results, the possibility of the existence of other fungal pathogens of grapevine which may cause foliar symptoms similar to eutypa dieback must not be dismissed. Further studies are required to determine whether any of these organisms are pathogenic towards grapevine, and whether they also produce toxic secondary metabolites.

If another member of the genus *Eutypa* is capable of causing a dieback disease of grapevines in Australia, this could have implications for the management of the disease. For example, the production and dispersal of ascospores of *E. lata* has been studied extensively. However, it is possible that other species of *Eutypa* may produce ascospores in different conditions, for example in areas with less than 350 mm of rainfall per year, which is the minimum precipitation required for the production of ascospores by *E. lata* (Carter, 1957a; Ramos *et al.*, 1975). *E. lata* is not believed to spread to the roots of infected vines (Creaser and Wicks, 2001). However, it is possible that other species may have the potential to grow in root tissue. This could have implications for the spread of the pathogen between vines, and would also need to be taken into consideration when re-planting or re-working affected vineyards. Similarly, it is possible that fungicides which inhibit ascospore germination or mycelial growth of *E. lata* may not be as efficient towards other species of *Eutypa* or related diatrypaceous fungi.

In California, Arizona and Northern Mexico, *Botryodiplodia theobromae* causes wedged-shaped cankers in grapevine which resemble those caused by *E. lata* (Leavitt, 2003). As for eutypa dieback, this disease, known as “Bot canker”, is slow to progress, with cordon death commencing a minimum of 4 years after infection (Leavitt, 2003). However, Bot canker does not cause foliar symptoms, hence infections may be noticed only following cordon death. Surveys conducted in New South Wales in 2002 revealed a large number of cankers in grapevines, from which *E. lata* could not be isolated (M. Creaser, *pers. com.*). Although Bot canker does not cause foliar symptoms, examination of dead cordons would reveal the presence of a *Eutypa*-like canker, hence the cause of death would be attributed to *E. lata*. Therefore, widespread surveys should be undertaken to determine whether *E. lata* is the only pathogen causing “eutypa dieback” of grapevine or whether related species of *Eutypa* or other fungi are capable of causing similar symptoms.

Although there are currently no products registered for the control of eutypa dieback in Australia, several compounds have shown potential as control agents (Creaser and Wicks, 2002). Field trials of these products are in progress and the DNA probes developed here will provide a rapid means of assessing the efficacy of these products. These probes can also be used to gather information regarding the rate of spread and distribution of the pathogen in infected vines. A greater understanding of the

---

epidemiology of the disease will allow for enhanced management of eutypa dieback in infected vines. When suitable control measures are developed, these could be used in conjunction with an early diagnostic test for the disease, possibly based on a chemical marker, to offer a means of limiting the economic losses caused by infection of vines by *E. lata*.





## Appendix A: Buffers and reagents

---

### CTAB extraction buffer (Green *et al.*, 1999)

Tris-HCL, pH 8.0	100 mM
NaCl	1.4 M
EDTA, pH 8.0	50 mM
CTAB	2.5 %
PVP-40	1 %
$\beta$ -mercaptoethanol	0.2 %

*Sterilise by autoclaving.*

### CTAB extraction buffer (Wolf *et al.*, 1999)

EDTA	20 mM
Tris-HCl, pH 8.0	100 mM
NaCl	1.4 M
CTAB	2 %
Urea	2.7 %
PVPP	2 %

*Sterilise by autoclaving.*

### Denaturing solution

NaCl	1.5 M
NaOH	0.5 M

### Denhardts III (100 ml)

tetrasodium pyrophosphate	5 %
SDS	10 %
Ficoll 400	2 %
Gelatin	2 %
PVP (MW 360,000)	2 %

*Dissolve in the above order over moderate heat. Filter entire solution through Whatman<sup>®</sup> No. 1 filter paper at 65 °C overnight.*

### 10 % Dextran sulphate (400 ml)

Dextran sulphate	40 g
dd H <sub>2</sub> O	300 ml

*Dissolve dextran sulphate in 300 ml dd H<sub>2</sub>O, adjust volume to 400 ml, sterilise by autoclaving. Store at 4 °C.*

### DNA extraction buffer for fungal mycelium (Péros *et al.*, 1996)

CTAB	2% (w/v)
NaCl	1.4 M
Tris-HCl, pH 8.0	100 mM
EDTA, pH 8.0	20 mM

*Sterilise by autoclaving.*

**Grinding buffer (Rott *et al.*, 2001)**

Sodium acetate, pH 5.2	0.2 M
EDTA	25 mM
Potassium acetate	1 M
PVP-40	2.5 %

*Sterilise by autoclaving.*

**5 X HSB**

3 M NaCl	3 M
Pipes	100 mM
Na <sub>2</sub> EDTA	25 mM

*Adjust to pH 6.8 with 4 M NaOH, Sterilise by autoclaving.*

**Luria Bertani (LB) broth (per litre)**

Bacto <sup>®</sup> -tryptone	10 g
Bacto <sup>®</sup> -yeast extract	5 g
NaCl	5 g

*Adjust pH to 7.0 with NaOH and sterilise by autoclaving.*

**LBamp broth**

*add to above solution*

Ampicillin (50 mg/ml)      20 µl/10 ml

**LB agar**

*add to LB broth*

Bacto<sup>®</sup> agar      15 g

**LBamp**

*add to LB agar*

Ampicillin (50 mg/ml)      20 µl/10 ml

**LB plates with ampicillin/IPTG/X-Gal      To LB agar**

Ampicillin (50 mg/ml)	20 µl/10 ml
X-gal	2 %
IPTG	0.1 M

**Neutralising solution**

NaCl	1.5 M
Tris-HCl (pH 7.5)	0.5 M

**Oligolabeling buffer**

d(ATP,TTP,GTP)	40 mM
Tris-HCl, pH 7.6	100 mM
NaCl	100 mM
MgCl <sub>2</sub>	20 mM
Acetylated DNase free BSA	200 mg/ml

*To prepare buffer, add 1.21 g Tris, 0.5844 g NaCl, and 0.4066 g MgCl<sub>2</sub>.7H<sub>2</sub>O to 100 ml of dd H<sub>2</sub>O, and adjust to pH 7.6 with concentrated HCl. Then add BSA and d(ATP, TTP, GTP), dispense buffer into 500 µl aliquots and store at -20°C.*

**Pre-hybridisation buffer**

Water	2 ml
5 X HSB	3 ml
Denhardtts III	2 ml
10 % dextran sulphate	3 ml
Sonicated herring sperm	250 µl (10 mg/ml)

*Mix and incubate for at least 15 min at 65°C. At the same time boil herring sperm DNA for 6 min, then chill on ice. Add to warm pre-hybridisation solution and incubate for a further 15 min.*

**Re-suspended silica**

Silica particles (Sigma S5631)	60 g
dd H <sub>2</sub> O	500 ml

*Mix silica in dd H<sub>2</sub>O and allow to settle for 24 h. Remove and discard the upper 470 ml of supernatant, add an additional 500 ml of dd H<sub>2</sub>O, mix well and allow to settle for 5 h. Remove and discard the upper 440 ml of supernatant, then adjust the pH of the remaining solution to 2.0 using concentrated HCl. Autoclave and store in a dark bottle at 4°C.*

**SEAPS extraction buffer (Melanson *et al.*, 2002)**

NaCl	1.5 M
Sodium acetate	0.15 M
EDTA	0.05 M
Sarkosyl	2.5 %
PVP-10	2.5 %
Ethanol	20 %

*Adjust pH to 5.4*

**Sephadex G-100**

TES buffer	300 mL
Sephadex G-100	10 g

*Incubate with gentle shaking for 2 h at 65°C, store at room temperature.*

**SOC medium (1 litre)**

Bacto <sup>®</sup> -tryptone	20 g
Bacto <sup>®</sup> -yeast extract	5 g
NaCl	0.6 g
KCl	0.19 g
MgSO <sub>4</sub> .7H <sub>2</sub> O	1 M
MgCl <sub>2</sub>	1 M
2 M glucose	1 ml

*Add Bacto<sup>®</sup>-tryptone, Bacto<sup>®</sup>-yeast extract, NaCl and KCl to 97 ml dd H<sub>2</sub>O. Stir to dissolve. Autoclave and cool to room temperature. Add MgSO<sub>4</sub>.7H<sub>2</sub>O, MgCl<sub>2</sub> and glucose. Bring to 100 ml with sterile dd H<sub>2</sub>O. Filter through a 0.2 µm filter.*

**Sodium iodide**

Na <sub>2</sub> SO <sub>3</sub>	0.75 g
NaI	36 g
dd H <sub>2</sub> O	40 ml

*Dissolve Na<sub>2</sub>SO<sub>3</sub> in dd H<sub>2</sub>O, then add NaI. Store in a dark bottle at 4 °C.*

**20 x SSC**

NaCl	3 M
Tri-sodium citrate	0.3 M

**Sonicated herring sperm)**

Herring sperm DNA	1.0 g
dd H <sub>2</sub> O	100 ml

*Sterilise by autoclaving, store at 4 °C.*

**TES buffer**

Tris-HCL	10 mM
EDTA	1 mM
SDS	0.1 %

*Adjust pH to 7.5, sterilise by autoclaving.*

**Tris-Acetate-EDTA (TAE) buffer**

Tris-HCl	40 mM
Sodium acetate	20 mM
EDTA	1 mM

*Prepared as a 50 x solution, pH adjusted to 8.0 with glacial acetic acid, sterilise by autoclaving.*

**Tris-Borate-EDTA (TBE) buffer**

Tris-borate	45 mM
EDTA	1 mM

*Prepare as a 5 x solution, sterilise by autoclaving.*

**Tris-EDTA (TE) buffer**

Tris-HCl	10 mM
EDTA	1 mM

*Sterilise by autoclaving.*

**Wash buffer (Rott and Jelkmann, 2001)**

Tris-HCl, pH 7.5	10 mM
EDTA	0.5 mM
NaCl	50 mM
Ethanol	50 %

*Sterilise by autoclaving.*

## Appendix B: Fungal growth media

---

*All media were sterilised by autoclaving at 121°C for 20 min.*

### **Malt/yeast broth (per litre)**

Malt extract (Difco, USA)	20 g
Yeast extract (Difco)	10 g
RO water	1000 ml

### **½ Malt/yeast broth (per litre)**

Malt extract	10 g
Yeast extract	5 g
RO water	1000 ml

### **Pezet's medium (per litre) (Pezet, 1983)**

KH <sub>2</sub> PO <sub>4</sub>	1 g
NaCl	0.5 g
CaCl <sub>2</sub> .2H <sub>2</sub> O	0.1 g
KNO <sub>3</sub>	5 g
MgSO <sub>4</sub> .7H <sub>2</sub> O	1 g
Glucose	10 g
Sucrose	5 g
Maltose	10 g
FeCl <sub>3</sub> (5 mg/mL)	1 ml
Trace element solution	1 ml
RO water	1000 ml

### **Trace element solution (100 ml) (Pezet, 1983)**

MnCl <sub>2</sub> .4H <sub>2</sub> O	78.6 mg
ZnSO <sub>4</sub> .7H <sub>2</sub> O	17.7 mg
MnCl <sub>2</sub> .4H <sub>2</sub> O	78.6 mg
CuSO <sub>4</sub> .5H <sub>2</sub> O	15.6 mg
CaCl <sub>2</sub>	20 mg
H <sub>3</sub> BO <sub>3</sub>	50 mg
(NH <sub>4</sub> ) <sub>6</sub> Mo <sub>7</sub> O <sub>24</sub> .4H <sub>2</sub> O	21.2 mg
RO water	100 ml

### **Potato dextrose agar (PDA) (per litre)**

PDA (Difco)	39 g
RO water	1000 ml

### **½ PDA (per litre)**

PDA (Difco)	19.5 g
Bitek agar (Difco)	7.5 g
RO water	1000 ml

**¼ PDA (per litre)**

PDA (Difco)	9.7 g
Bitek agar (Difco)	3.75 g
RO water	1000 ml

**Potato dextrose broth (PDB) (per litre)**

PDB (Difco)	24 g
RO water	1000 ml

**½ Potato dextrose broth (per litre)**

PDB	12 g
RO water	1000 ml

**Vogel's medium (per litre)**

Vogel's medium (Vogel, 1964)	20 ml
Sucrose	20 g
RO water	980 ml

**½ Vogel's medium (per litre)**

Vogel's medium (Vogel, 1964)	10 ml
Sucrose	10 g
RO water	980 ml

**¼ Vogel's medium (per litre)**

Vogel's medium (Vogel, 1964)	5 ml
Sucrose	5 g
RO water	980 ml

**Vogel's agar (per litre)**

To 1000 ml Vogel's medium add 15 g Bitek agar (Difco)

**½ Vogel's agar (per litre)**

To 1000 ml ½ Vogel's medium add 15 g Bitek agar (Difco)

**¼ Vogel's agar (per litre)**

To 1000 ml ¼ Vogel's medium add 15 g Bitek agar (Difco)

**Grapevine extract media**

*Grapevine extract media were derived from 1-year-old Cabernet Sauvignon canes which were ground in a Wiley mill with a 1 mm screen.*

**Grapevine wood medium (per 250 ml flask)**

Milled grapevine wood	10 g
RO water	50 ml

**Grapevine wood medium + sucrose (per 250 ml flask)**

Milled grapevine wood	10 g
Sucrose	10 g
RO water	50 ml

**Liquid cane extract (per litre)**

Milled grapevine wood	200 g
RO water	1000 ml

*Sonify 200 g ground cane with 1000 ml boiling RO water and clarify by filtration through a series of filters: Miracloth (CalBiochem, USA), multigrade GMF 150 (Whatman, England), GF/F (Whatman) and Supor-200 0.2 µm (Gelman, USA). Bring volume back to 1000 ml with RO water.*

**Liquid cane extract + sucrose (per litre)**

*Prepared as above, with the addition of 20 g sucrose per litre.*

**Cane extract agar (per litre)**

*To 1000 ml liquid cane extract add 15 g Bitek agar (Difco, USA)*

**Cane extract agar + sucrose (per litre)**

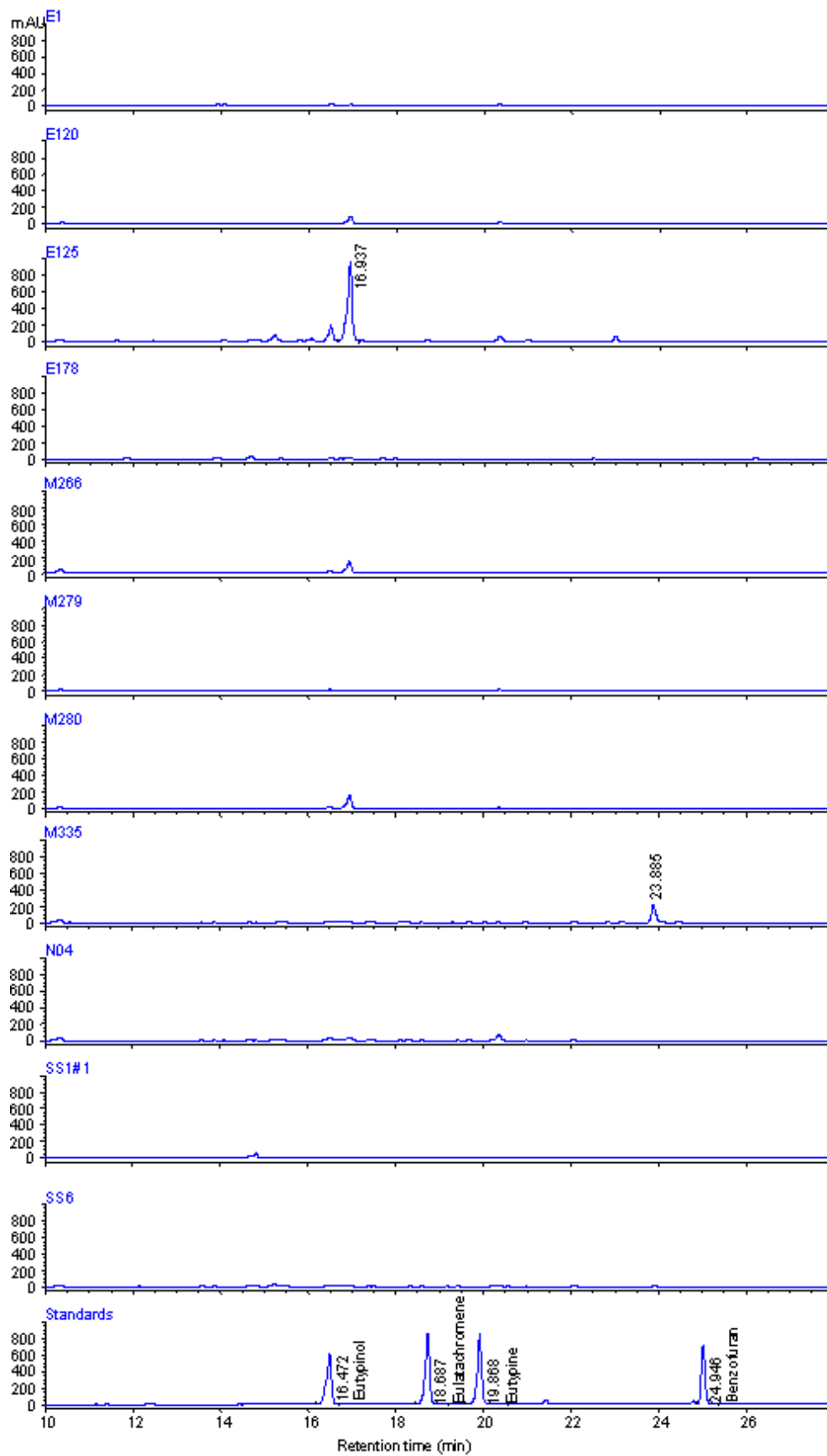
*To 1000 ml liquid cane extract + sucrose add 15 g Bitek agar (Difco, USA)*

## **Appendix C: HPLC chromatograms following growth of fungal isolates on artificial media**

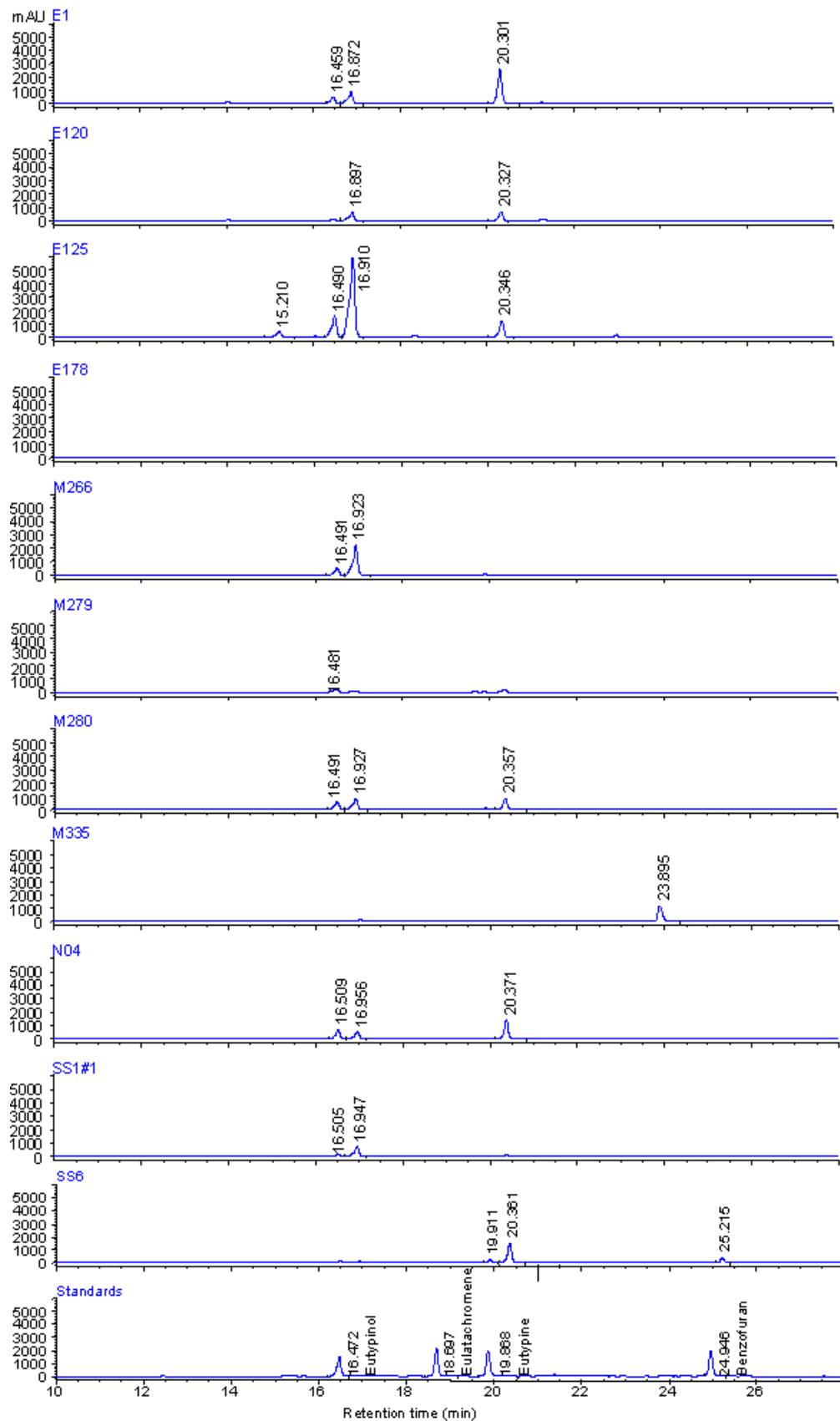
---

HPLC chromatograms not given in the text in Chapter 6 (Production of secondary metabolites on artificial media) are presented in this Appendix.

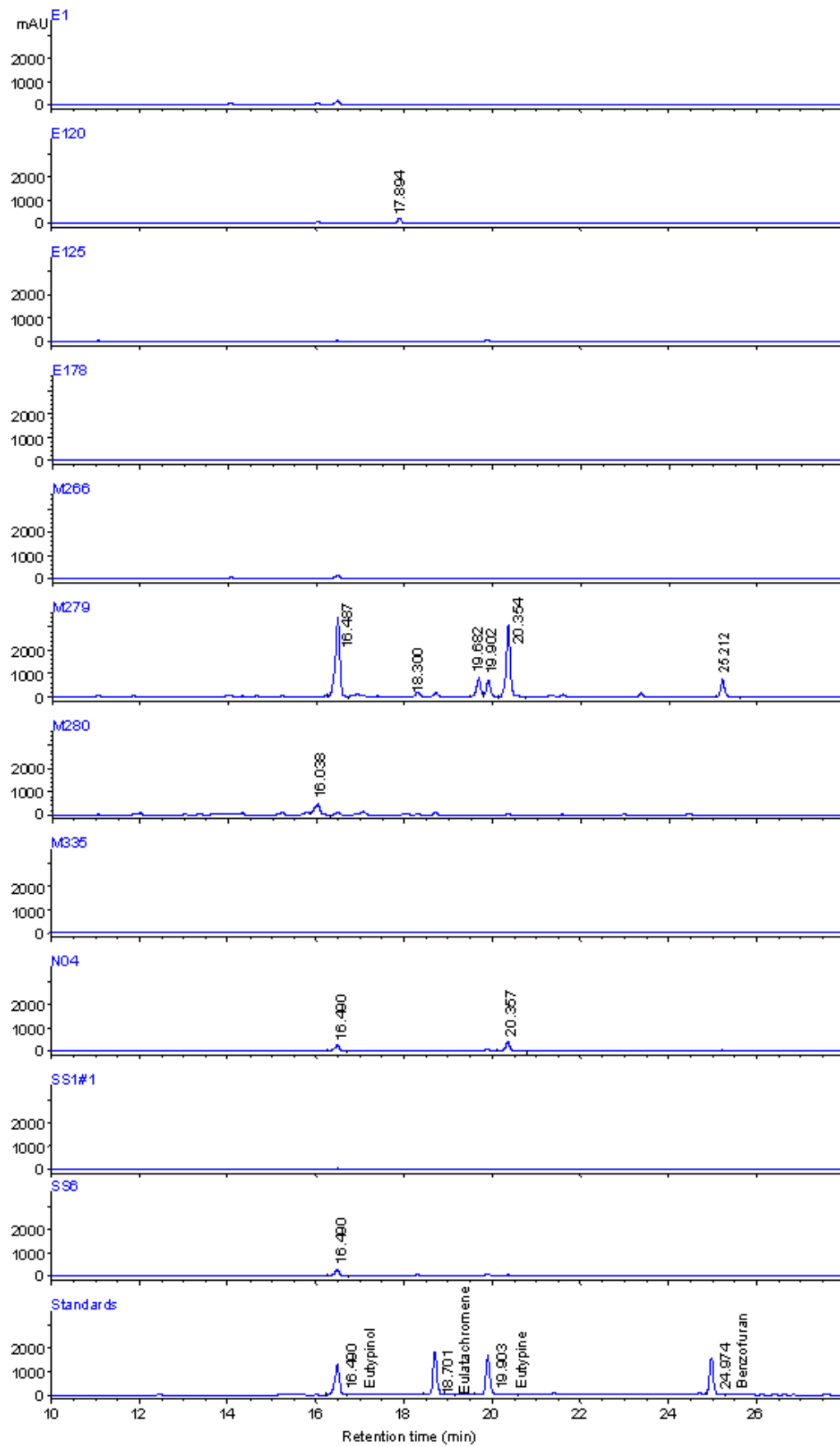




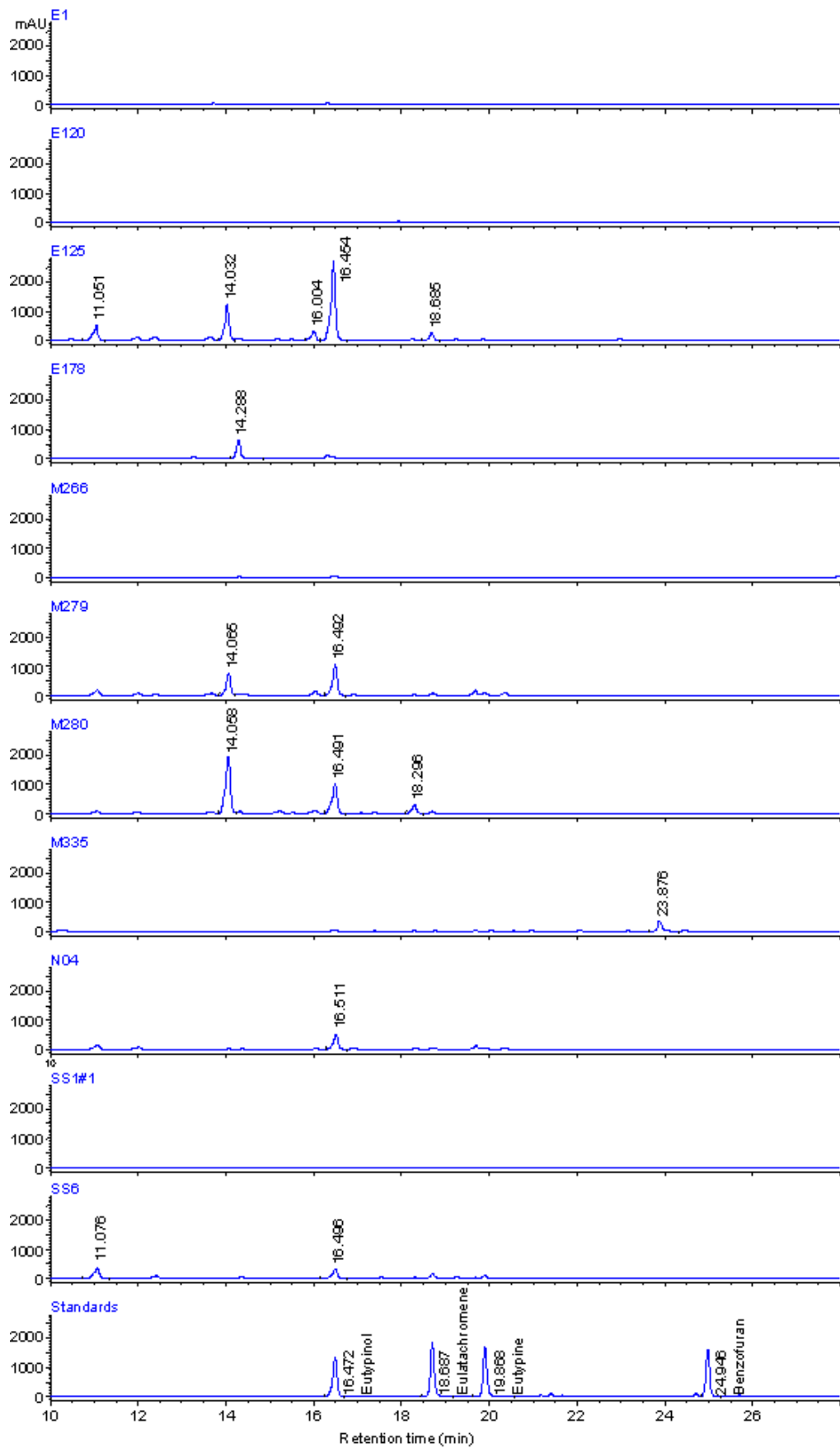
HPLC chromatograms showing secondary metabolite production of 11 isolates grown on stationary PDB for 30 days.



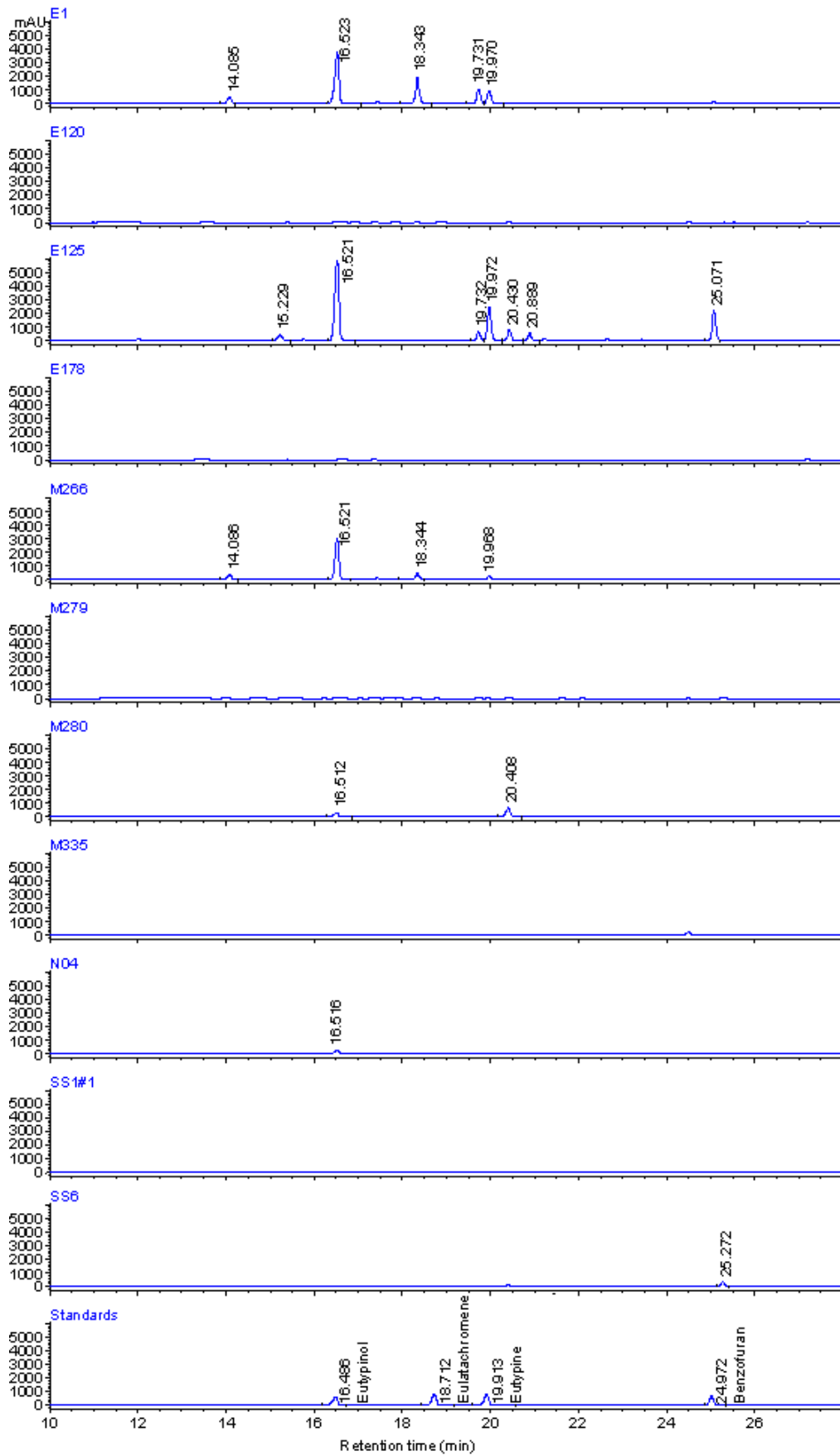
HPLC chromatograms showing secondary metabolite production of 11 isolates grown on shaken PDB for 30 days.



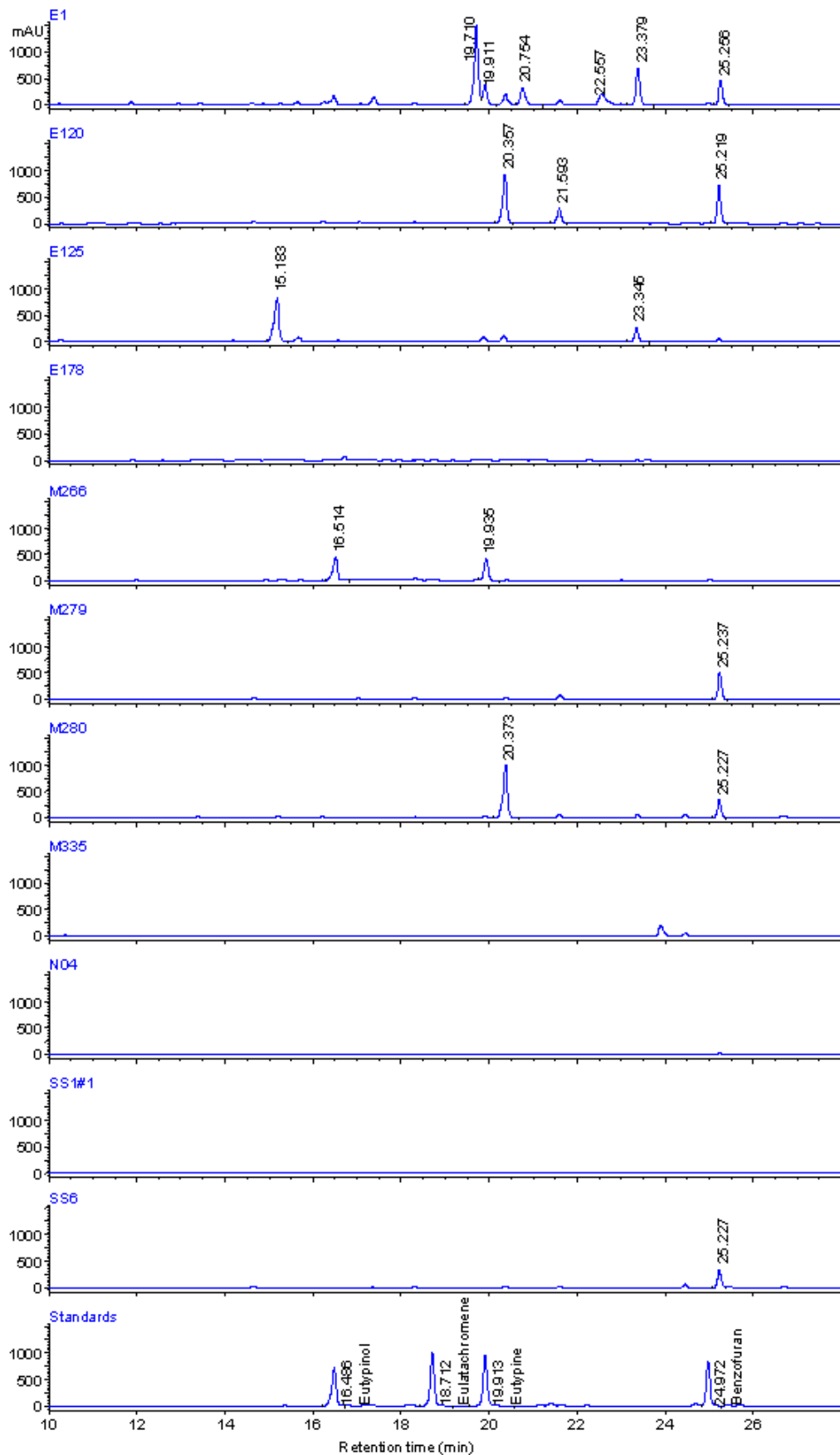
HPLC chromatograms showing secondary metabolite production of 11 isolates grown on stationary Pezet's broth for 30 days.



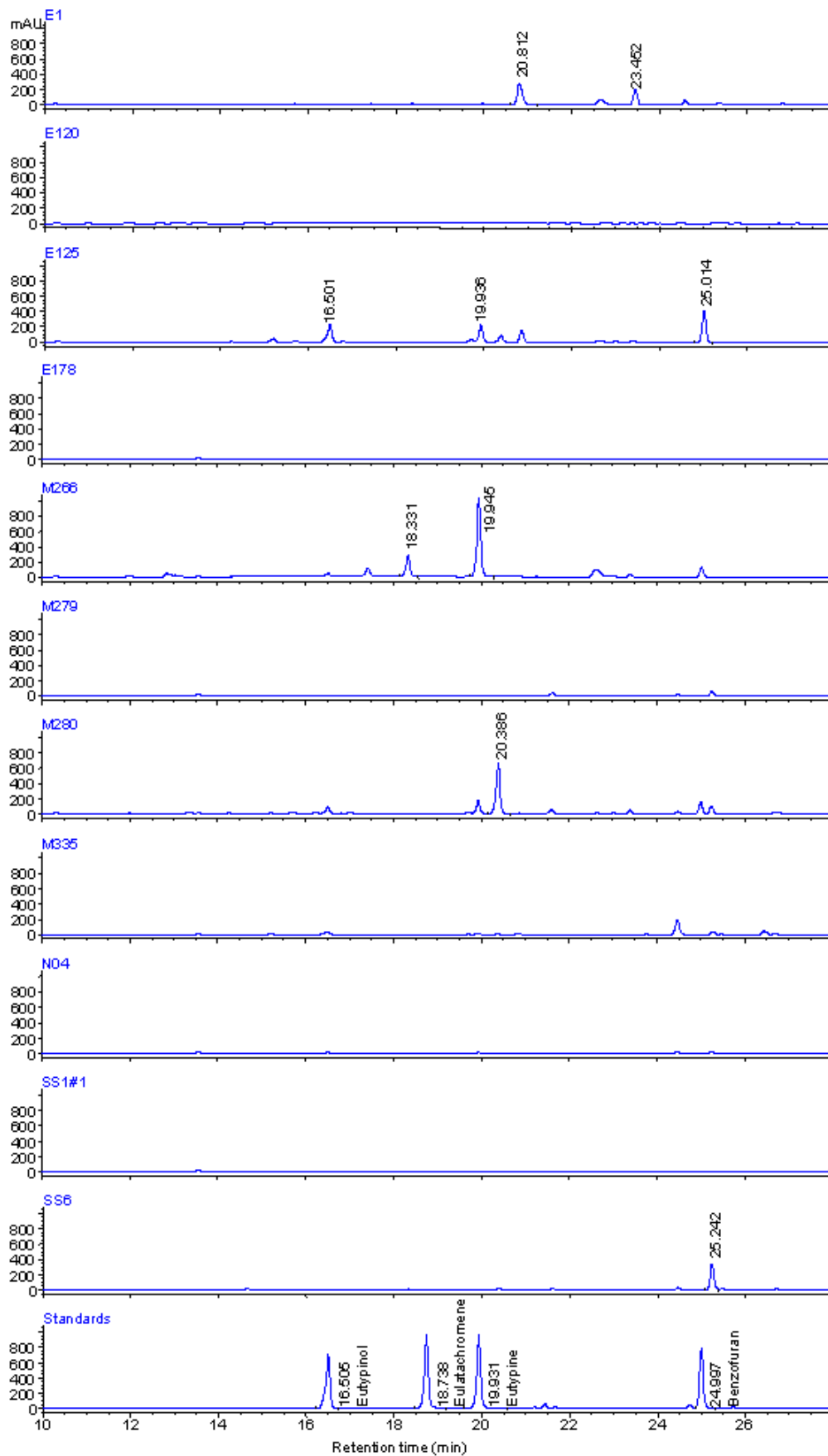
HPLC chromatograms showing secondary metabolite production of 11 isolates grown on shaken Pezet's broth for 30 days.



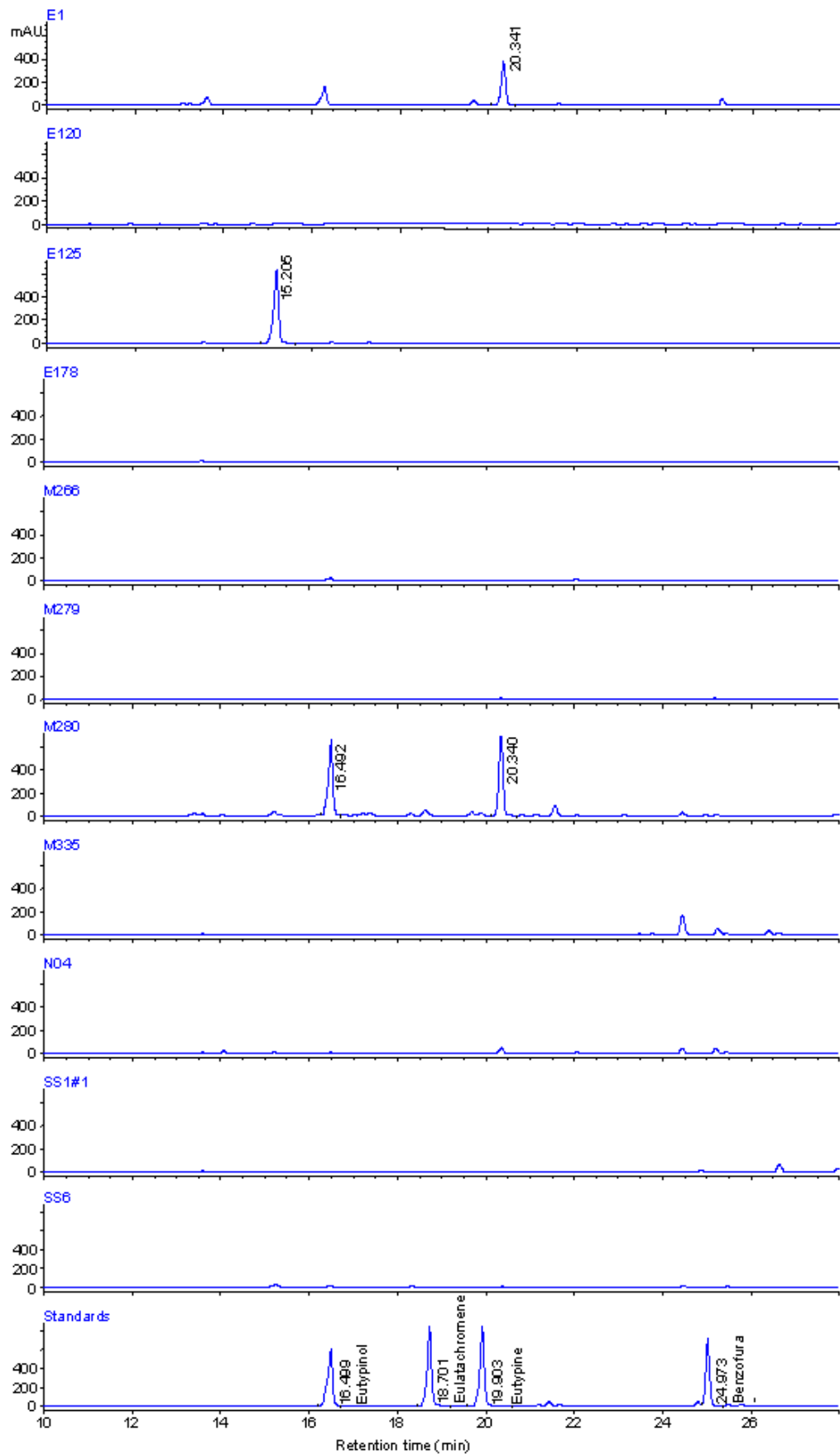
HPLC chromatograms showing secondary metabolite production of 11 isolates grown on stationary Vogel's medium for 20 days.



HPLC chromatograms showing secondary metabolite production of 11 isolates grown on stationary Vogel's medium for 24 days.

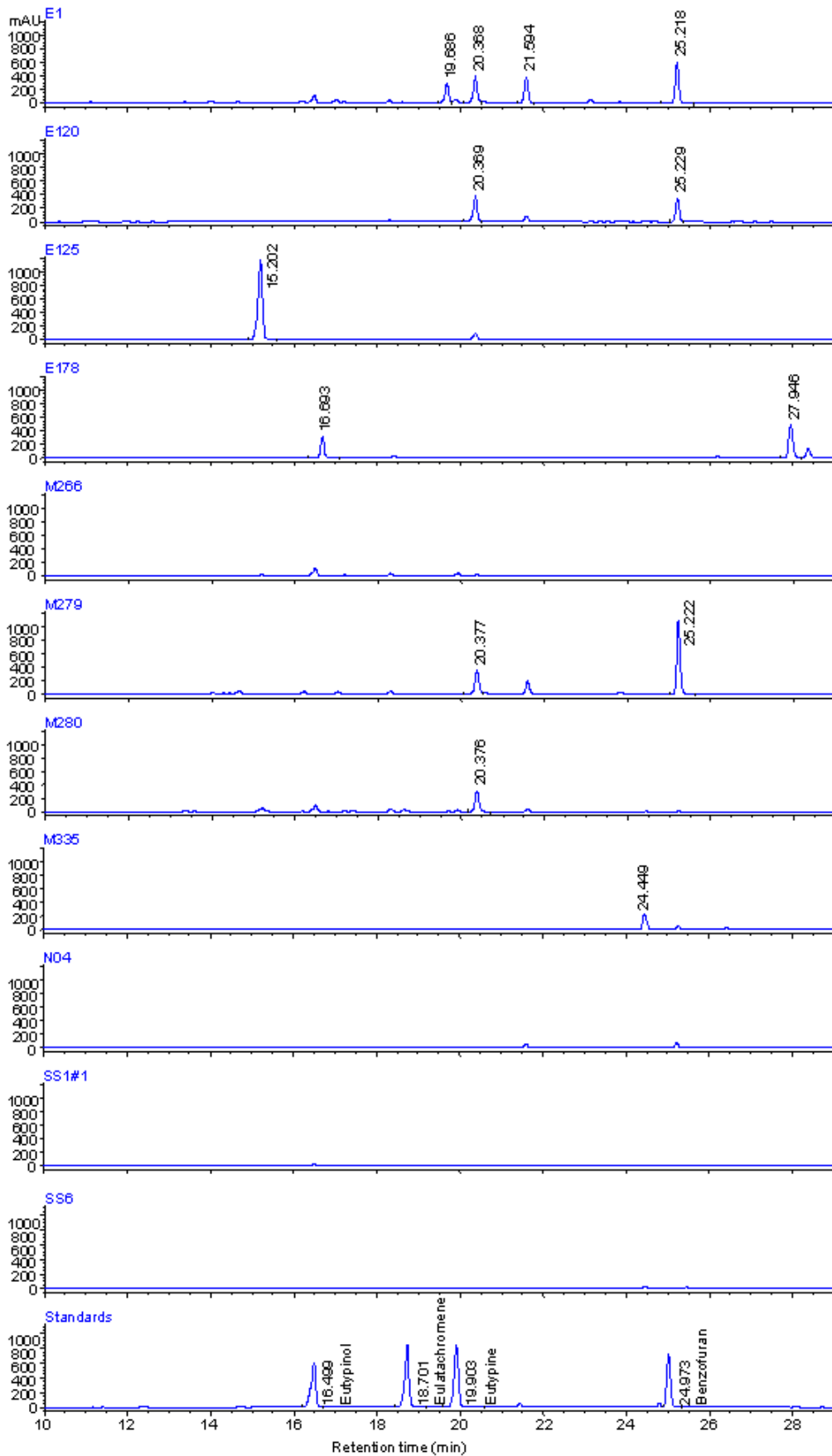


HPLC chromatograms showing secondary metabolite production of 11 isolates grown on stationary Vogel's medium for 30 days.



HPLC chromatograms showing secondary metabolite production of 11 isolates grown on shaken Vogel's medium for 20 days.



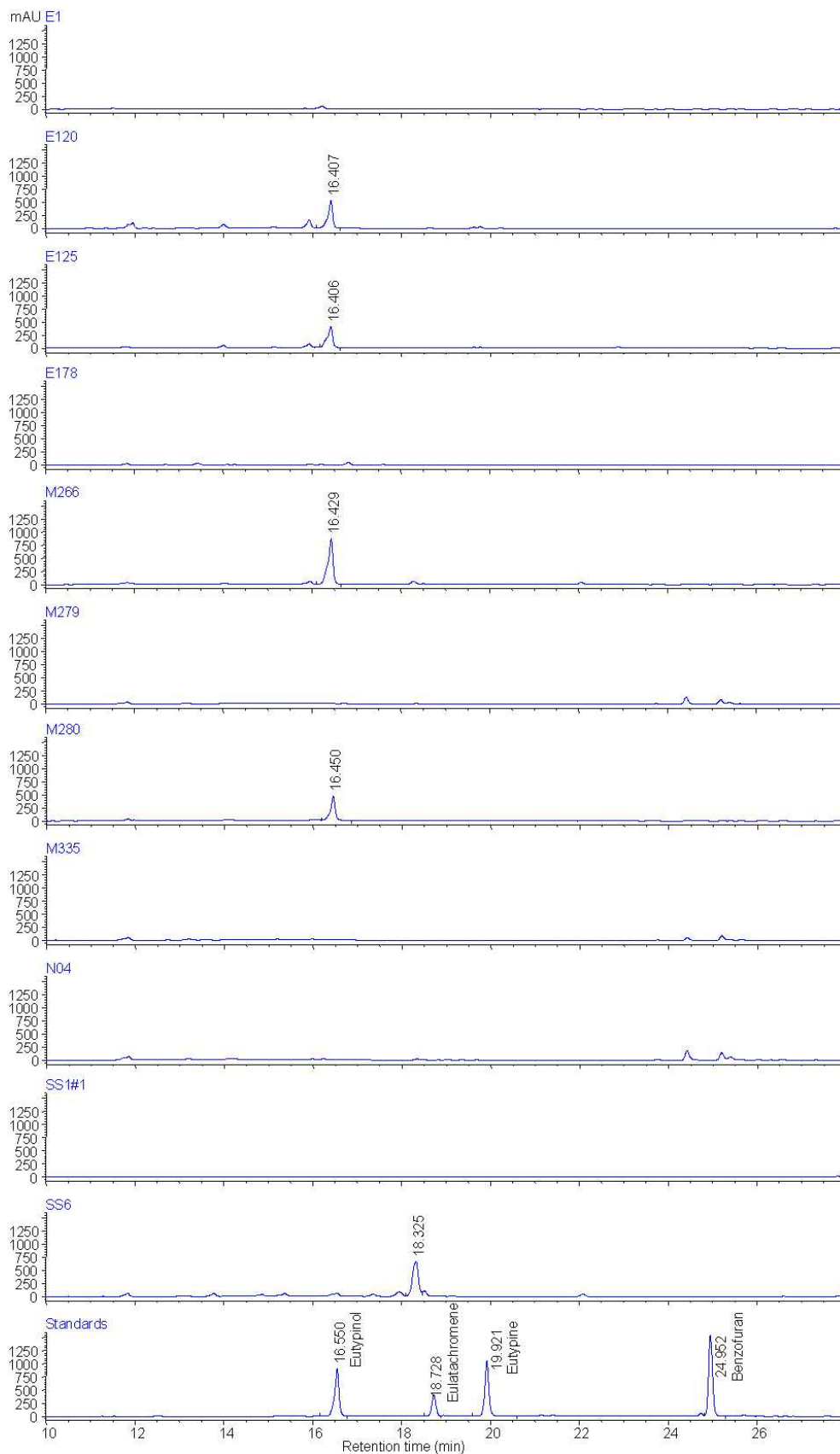


HPLC chromatograms showing secondary metabolite production of 11 isolates grown on shaken Vogel's medium for 24 days.

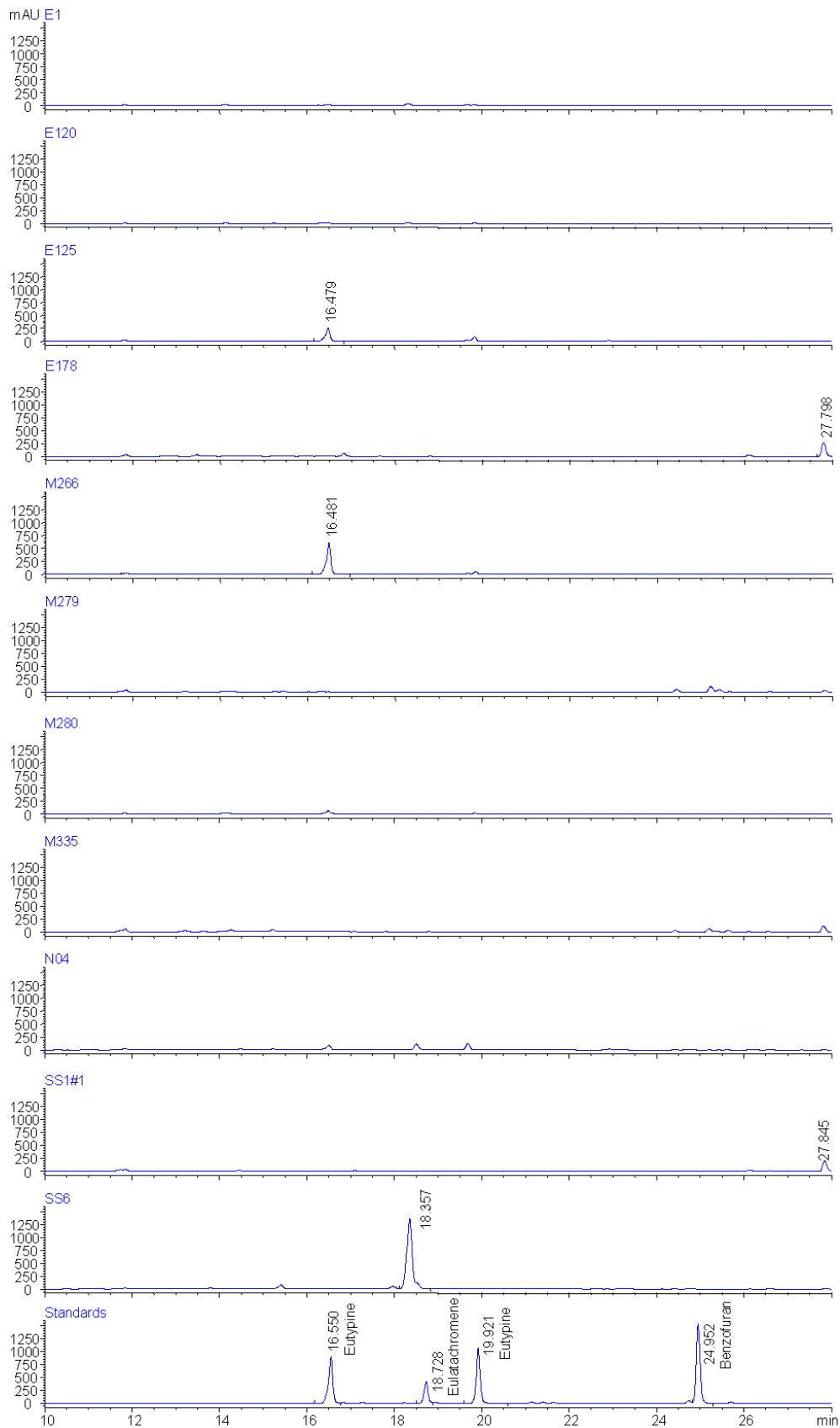
## **Appendix D: HPLC chromatograms following growth of fungal isolates on grapevine cane extracts**

---

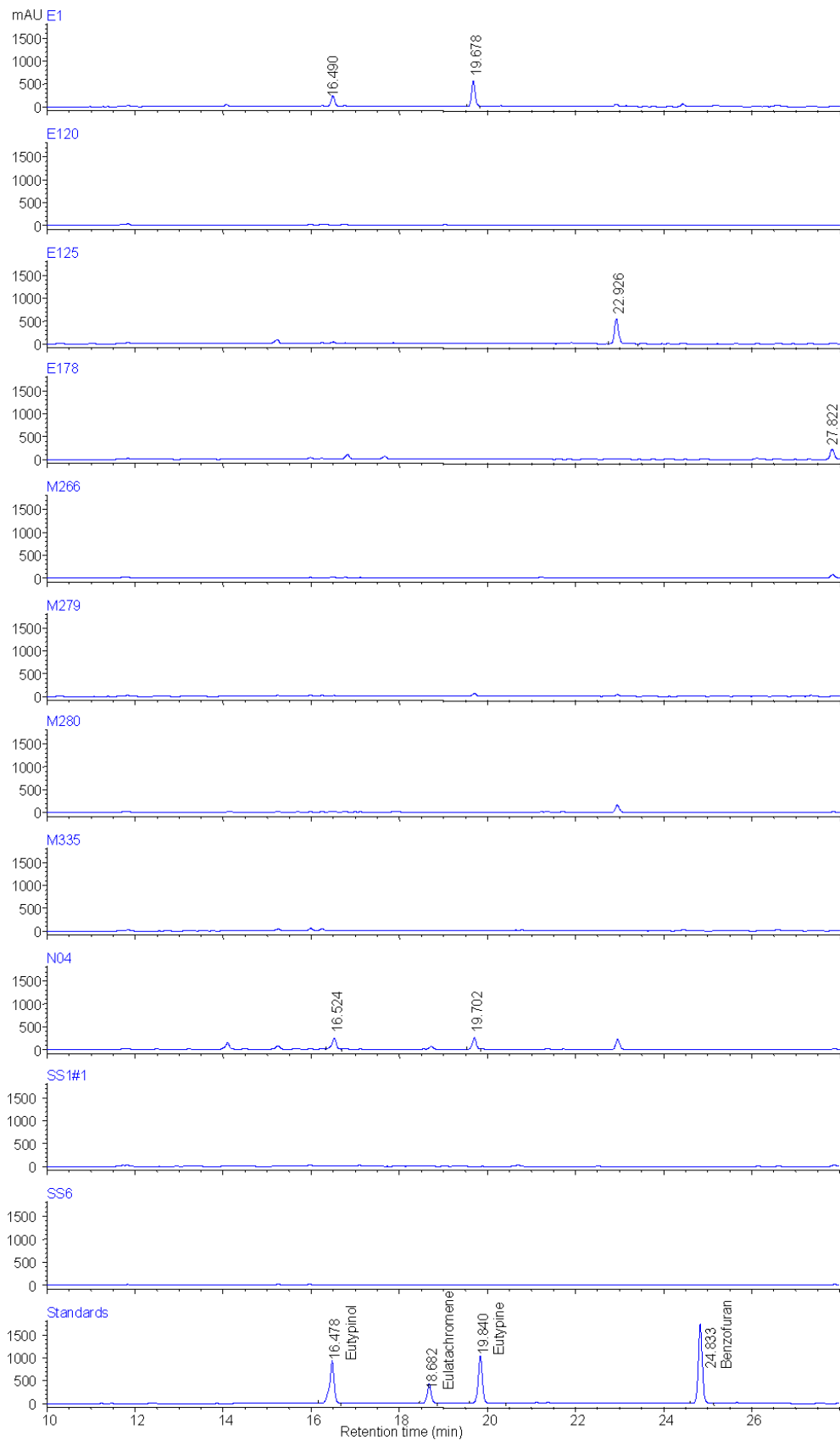
HPLC chromatograms not given in the text in Chapter 7 (Production of secondary metabolites on grapevine cane extracts) are presented in this Appendix.



HPLC chromatograms showing secondary metabolite production of 11 isolates grown on Cabernet Sauvignon wood medium for 20 days



HPLC chromatograms showing secondary metabolite production of 11 isolates grown on Cabernet Sauvignon wood medium for 30 d.



HPLC chromatograms showing secondary metabolite production of 11 isolates grown on Cabernet Sauvignon liquid cane extract for 30 d.

## References

---

- Adam, D.B. (1938). A progress report on a gummosis (dieback) disease in South Australian apricot trees. *Journal of the Department of Agriculture of South Australia* **42**, 14-29.
- Adam-Blonden, A.F., Seignac, M., Bannerot, H., and Dron, M. (1994). SCAR, RAPD, and RFLP markers linked to a dominant gene (Are) controlling resistance to anthracnose in common bean. *Theoretical and Applied Genetics* **88**, 865-870.
- Aldred, D., Magan, N., and Lane, B.S. (1999). Influence of water activity and nutrients on growth and production of squalestatin by a *Phoma* sp. *Journal of Applied Microbiology* **87**, 842-848.
- Altschul, S.F., Madden, T.L., Schäffer, A.A., Zhang, J., Zhang, Z., Miller, W., and Lipman, D.J. (1997). Gapped BLAST and PSI-BLAST: a new generation of protein database search programs. *Nucleic Acids Research* **25**, 3389-3402.
- Amborabé, B.-E., Fleurat-Lessard, P., Chollet, J.-F., and Roblin, G. (2002). Antifungal effects of salicylic acid and other benzoic acid derivatives towards *Eutypa lata*: structure–activity relationship. *Plant Physiology and Biochemistry* **40**, 1051-1060.
- Annamalai, P., Ishii, H., Lalithakumari, D., and Revathi, R. (1995). Polymerase chain reaction and its applications in fungal disease diagnosis. *Zeitschrift für Pflanzenkrankheiten und Pflanzenschutz* **102**, 91-104.
- Anon (1997). IPM viticulture: research to practice: training workshop manual. Department of Natural Resources and Environment, Institute for Horticultural Development, Knoxfield, Victoria, Australia.
- Bago, B., Pfeffer, P.E., Douds, D.D., Brouillette, J., Bécard, G., and Shachar Hill, Y. (1999). Carbon metabolism in spores of the arbuscular mycorrhizal fungus *Glomus intraradices* as revealed by nuclear magnetic resonance spectroscopy. *Plant Physiology* **121**, 263-271.
- Bahnweg, G., Schulze, S., Möller, E.M., Rosenbrock, H., Langebartels, C., and Sandermann, H. (1998). DNA isolation from recalcitrant materials such as tree roots, bark and forest soil for the detection of fungal pathogens by polymerase chain reaction. *Analytical Biochemistry* **262**, 79-82.
- Balali, G.R., Whisson, D.L., Scott, E.S., and Neate, S.M. (1996). DNA fingerprinting probe specific to isolates of *Rhizoctonia solani* AG-3. *Mycological Research* **100**, 467-470.

- Baxter, C.J., Magan, N., Lane, B., and Wildman, H.G. (1998). Influence of water activity and temperature on *in vitro* growth of surface cultures of a *Phoma* sp. and production of the pharmaceutical metabolites, squalestatins S1 and S2. *Applied Microbiology and Biotechnology* **49**, 328-332.
- Bayman, P., and Cotty, P.J. (1993). Genetic diversity in *Aspergillus flavus*: association with aflatoxin production and morphology. *Canadian Journal of Botany* **71**, 23-31.
- Belarbi, B., and Mur, G. (1983). Observations sur la germination des conidies ou stylospores du champignon *Eutypa armeniacae*. *Le Progrès Agriculture et Viticulture* **24**, 636-637.
- Benet, H., Guries, R.P., Boury, S., and Smalley, E.B. (1995). Identification of RAPD markers linked to a black leaf spot resistance gene in Chinese elm. *Theoretical and Applied Genetics* **90**, 1068-1073.
- Bertoluzza, A., Bottura, G., Lucchi, P., Marchetti, L., and Zechini D'Aulerio, A. (1999). Molecular monitoring of horse chestnut leaves affected with biotic and abiotic disorders. *Journal of Plant Pathology* **81**, 89-94.
- Black, W.C. (1996). Statistical analysis of arbitrarily primed PCR patterns in molecular taxonomic studies. In "Methods in Molecular Biology, Vol 50: Species Diagnostic Protocols: PCR and Other Nucleic Methods" (Clapp, J.P., ed.), pp. 39-55. Humana Press Inc., Totowa, New Jersey, U.S.A.
- Bode, H.B., Walker, M., and Zeeck, A. (2000a). Secondary metabolites by chemical screening, 41 structure and biosynthesis of mutolide, a novel macrolide from a UV mutant of the fungus F-249707. *European Journal of Organic Chemistry* **2000**, 1451-1456.
- Bode, H.B., Walker, M., and Zeeck, A. (2000b). Secondary metabolites by chemical screening, 42 cladospirones B to I from *Sphaeropsidales* sp. F-24'707 by variation of culture conditions. *European Journal of Organic Chemistry* **2000**, 3185-3193.
- Bolay, A., and Carter, M.V. (1985). Newly recorded hosts of *Eutypa lata* (synonym *Eutypa armeniacae*) in Australia. *Plant Protection Quarterly* **1**, 10-12.
- Boshoff, W.H.P., Swart, W.J., Pretorius, Z.A., Liebenberg, M.M., and Crous, P.W. (1996). Isozyme variability among isolates of *Phaeoisariopsis griseola* in Southern Africa. *Plant Pathology* **45**, 344-349.
- Bossi, R., Cole, L., Spier, A.D., and Dewey, F.M. (1994). Monoclonal antibody-based ELISA for detection of mycelial antigens of *Botrytis cinera* in fruit and

- vegetables. In "Modern Assays for Plant Pathogenic Fungi: Identification, Detection and Quantification" (Schots, A., Dewey, F.M. and Oliver, R., eds.), pp. 165-173. CAB International, Wallingford, Oxford, U.K.
- Braithwaite, K.S., Manners, J.M., Irwin, J.A.G., and MacLean, D.J. (1994). DNA markers reveal hybrids between two diverse background genotypes in Australian collections of the bean rust fungus *Uromyces appendiculatus*. *Australian Journal of Botany* **42**, 255-267.
- Buhariwalla, H., Greaves, S., Magrath, R., and Mithen, R. (1995). Development of specific PCR primers for the amplification of polymorphic DNA from the obligate root pathogen *Plasmodiophora brassicae*. *Physiological and Molecular Plant Pathology* **47**, 83-94.
- Caldas, E.D., Sadilkova, K., Ward, B.L., Jones, A.D., Winter, C.K., and Gilchrist, D.G. (1998). Biosynthetic studies of fumonisin B<sub>1</sub> and AAL toxins. *Journal of Agricultural and Food Chemistry* **46**, 4734-4743.
- Cannon, P. (1991). Taxonomy and nomenclature of the pathogen. In "The status of *Eutypa lata* as a pathogen" (Carter, M.V., ed.), pp. 9-13. CAB International, Wallingford, Oxford, U.K.
- Carter, M.V. (1957a). *Eutypa armeniaca* Hansf. and Carter, sp. nov., an airborne vascular pathogen of *Prunus armeniaca* L. in southern Australia. *Australian Journal of Botany* **5**, 21-35.
- Carter, M.V. (1957b). Vines aid spread of apricot "gummosis". *Journal of the Department of Agriculture of South Australia* **60**, 482-483.
- Carter, M.V. (1960). Further studies on *Eutypa armeniaca* Hansf. & Carter. *Australian Journal of Agricultural Research* **11**, 498-504.
- Carter, M.V. (1991). "The status of *Eutypa lata* as a pathogen," CAB International, Wallingford, Oxford, U.K.
- Carter, M.V., Bolay, A., and Rappaz, F. (1983). An annotated host list and bibliography of *Eutypa armeniaca*. *Review of Plant Pathology* **62**, 251-258.
- Carter, M.V., and Price, T.V. (1974). Biological control of *Eutypa armeniaca*. II. Studies of the interaction between *E. armeniaca* and *Fusarium lateritium*, and their relative sensitivities to benzimidazole chemicals. *Australian Journal of Agricultural Research* **25**, 105-119.
- Carter, M.V., and Price, T.V. (1975). Biological control of *Eutypa armeniaca*. III. A comparison of chemical, biological and integrated control. *Australian Journal of Agricultural Research* **26**, 537-543.



- Chakrabarti, R., and Schutt, C.E. (2001). The enhancement of PCR amplification by low molecular weight amides. *Nucleic Acids Research* **29**, 2377-2381.
- Chapuis, L., Corio-Costet, M.-F., and Malosse, C. (1996). Sterol composition of the woody plant pathogenic fungus *Eutypa lata*. *Phytochemistry* **42**, 1599-1601.
- Chapuis, L., Richard, L., and Dubos, B. (1998). Variation in susceptibility of grapevine pruning wounds to infection by *Eutypa lata* in south-western France. *Plant Pathology* **47**, 463-472.
- Christiansen, S.K., and Giese, H. (1990). Genetic analysis of the obligate barley powdery mildew fungus based on RFLP and virulence loci. *Theoretical and Applied Genetics* **79**, 705-712.
- Coleman, L.C. (1928). The deadarm disease of grapes in Ontario. A preliminary study. *Scientific Agriculture* **8**, 281-315.
- Colrat, S., Deswarte, C., Latché, A., Klaébé, A., Bouzayen, M., Fallot, J., and Roustan, J.P. (1999b). Enzymatic detoxification of eutypine, a toxin from *Eutypa lata*, by *Vitis vinifera* cells: partial purification of an NADPH-dependent aldehyde reductase. *Planta* **207**, 544-550.
- Colrat, S., Latché, A., Guis, M., Pech, J.-C., Bouzayen, M., Fallot, J., and Roustan, J.P. (1999a). Purification and characterisation of a NADPH-dependent aldehyde reductase from mung bean that detoxifies eutypine, a toxin from *Eutypa lata*. *Plant Physiology* **119**, 621-626.
- Cooke, D.E.L., Kennedy, D.M., Guy, D.C., Russell, J., Unkles, S.E., and Duncan, J.M. (1996). Relatedness of group I species of *Phytophthora* as assessed by randomly amplified polymorphic DNA (RAPDs) and sequences of ribosomal DNA. *Mycological Research* **100**, 297-303.
- Cortesi, P., and Milgroom, M.G. (2001). Outcrossing and diversity of vegetative compatibility types in populations of *Eutypa lata* from grapevines. *Journal of Plant Pathology* **83**, 79-86.
- Couch, J.A., and Fritz, P.J. (1990). Isolation of DNA from plants high in polyphenolics. *Plant Molecular Biology Reporter* **8**, 8-12.
- Creaser, M., and Wicks, T.J. (2001). Yearly variation in eutypa dieback symptoms and the relationship to grapevine yield. *The Australian Grapegrower and Winemaker* **452**, 50-52.
- Creaser, M., and Wicks, T.J. (2002). Evaluation of fungicides, paints and a biological product for the prevention of eutypa dieback of grapevines. *The Australian and New Zealand Grapegrower and Winemaker* **464**, 15-18.

- Crowhurst, R.N., Hawthorne, B.T., Rikkerink, E.H.A., and Templeton, M.D. (1991). Differentiation of *Fusarium solani* f.sp. *cucurbitae* races 1 and 2 by random amplification of polymorphic DNA. *Current Genetics* **20**, 391-396.
- DeScenzo, R.A., Engel, S.R., Gomez, G., E.L., J., Munkvold, G.P., Weller, J., and Irelan, N.A. (1999). Genetic analysis of *Eutypa* strains from California supports the presence of two pathogenic species. *Phytopathology* **89**, 884-893.
- Deswarte, C., Canut, H., Klaébé, A., Roustan, J.P., and Fallot, J. (1996a). Transport, cytoplasmic accumulation and mechanism of action of the toxin eutypine in *Vitis vinifera* cells. *Journal of Plant Physiology* **149**, 336-342.
- Deswarte, C., Eychenne, J., de Virville, J.D., Roustan, J.P., Moreau, F., and Fallot, J. (1996b). Protonophoric activity of eutypine, a toxin from *Eutypa lata*, in plant mitochondria. *Archives of Biochemistry and Biophysics* **334**, 200-205.
- Deswarte, C., Rouquier, P., Roustan, J.P., Dargent, R., and Fallot, J. (1994). Ultrastructural changes produced in plantlet leaves and protoplasts of *Vitis vinifera* cv. Cabernet Sauvignon by eutypine, a toxin from *Eutypa lata*. *Vitis* **33**, 185-188.
- Dewey, F.M., and Priestley, R.A. (1994). A monoclonal antibody-based immunoassay for the detection of the eyespot pathogen of cereals, *Pseudocercospora herpotrichoides*. In "Modern Assays for Plant Pathogenic Fungi: Identification, Detection and Quantification" (Schots, A., Dewey, F.M. and Oliver, R., eds.), pp. 9-16. CAB International, Wallingford, Oxford, U.K.
- Dewey, F.M., and Thornton, C.R. (1995). Fungal immunodiagnosics in plant agriculture. In "New Diagnostics in Crop Science" (Skerritt, J.H. and Appels, R., eds.), pp. 1-32. CAB International, Wallingford, Oxford, U.K.
- Dingley, J.M. (1960). *Eutypa* canker of apricot. *Orchardist of New Zealand* **33**, 78-79.
- Dubin, G.M., Fkyerat, A., and Tabacchi, R. (2000). Acetylenic aromatic compounds from *Stereum hirsutum*. *Phytochemistry* **53**, 571-574.
- Duthie, J.A., and Marois, J.J. (1991). Spatial patterns of *Eutypa* dieback in California vineyards. *Phytopathology* **81**, 1183.
- Duthie, J.A., Munkvold, G.P., Marois, J.J., Grant, S., and Chellemi, D.O. (1991). Relationship between age of vineyard and incidence of *Eutypa* dieback. *Phytopathology* **81**, 1183.
- Dye, M.H., and Carter, M.V. (1976). Association of *Eutypa armeniaca* and *Phomopsis viticola* with a dieback disease of grapevines in New Zealand. *Australasian Plant Pathology Society Newsletter* **5**, 6-7.

- Eastwell, K.C., Willis, L.G., and Cavileer, T.D. (1995). A rapid and sensitive method to detect *Agrobacterium vitis* in grapevine cuttings using the polymerase chain reaction. *Plant Disease* **79**, 822-827.
- Edel, V. (1998). Polymerase Chain Reaction in Mycology: An Overview. In "Applications of PCR in Mycology", pp 1-20, (Bridge, P.D., Arora, D.K., Reddy, C.A. and Elander, R.P., eds.). CAB International, Wallingford, Oxford, U.K.
- Egel, D.S., Cotty, P.J., and Elias, K.S. (1994). Relationships among isolates of *Aspergillus* sect. *flavi* that vary in aflatoxin production. *Phytopathology* **84**, 906-912.
- English, H., and Davis, J.R. (1965). Pathogenic activity of *Eutypa armeniaca* in apricot. *Phytopathology* **55**, 1057.
- Evidente, A., Capasso, R., Vurro, M., and Bottalico, A. (1993). Ascosalitoxin, a phytotoxic trisubstituted salicylic aldehyde from *Ascochyta pisi*. *Phytochemistry* **34**, 995-998.
- Evidente, A., Sparapano, L., Andolfi, A., and Bruno, G. (2000). Two naphthalenone pentaketides from liquid cultures of *Phaeoacremonium aleophilum*, a fungus associated with esca of grapevine. *Phytopathologia Mediterranea* **39**, 162-168.
- Fabré, J.V., Julien, J., Parisot, D., and Dron, M. (1995). Analysis of diverse isolates of *Colletotrichum lindemuthianum* infecting common bean using molecular markers. *Mycological Research* **99**, 429-465.
- Fegan, M., Manners, J.M., Maclean, D.J., Irwin, J.A.G., Samuels, K.D.Z., Holdom, D.G., and Li, D.P. (1993). Random amplified polymorphic DNA markers reveal a high degree of genetic diversity in the entomopathogenic fungus *Metarhizium anisopliae* var. *anisopliae*. *Journal of General Microbiology* **139**, 2075-2081.
- Felsenstein, J. (1985). Confidence limits in phylogenies: An approach using the bootstrap. *Evolution* **39**, 783-791.
- Felsenstein, J. (1995). PHYLIP (Phylogeny Interface Package) version 3.5c. Department of Genetics, University of Washington, Seattle, U.S.A. Distributed by the author.
- Ferreira, J.H.S. (1988). Dieback of grapevines in South Africa. PhD thesis, University of the Western Cape, 7530 Bellville, Republic of South Africa.
- Ferreira, J.H.S. (1999). Growth of *Eutypa lata* in grapevine wood extracts. *South African Journal for Enology and Viticulture* **20**, 53-56.

- Ferreira, J.H.S., and Augustyn, O.P.H. (1989). Differentiation between *Eutypa lata* and *Cryptovalsa cf ampelina* by means of cellular fatty acid analysis. *South African Journal for Enology and Viticulture* **10**, 18-22.
- Ferreira, J.H.S., Matthee, F.N., and Thomas, A.C. (1991). Biological control of *Eutypa lata* on grapevine by an antagonistic strain of *Bacillus subtilis*. *Phytopathology* **81**, 283-287.
- Fletcher, R.S., Skaria, M., Escobar, D.E., and Everitt, J.H. (2001). Field spectra and airborne digital imagery for detecting Phytophthora foot rot infections in citrus trees. *HortScience* **36**, 94-97.
- Förster, H., and Adaskaveg, J.E. (2000). Early brown rot infections in sweet cherry fruit are detected by *Monilinia*-specific DNA primers. *Phytopathology* **90**, 171-178.
- Francki, R.I.B., and Carter, M.V. (1970). The serological properties of *Eutypa armeniacae* mycelium and ascospores. *Australian Journal of Biological Sciences* **23**, 713-716.
- Francki, R.I.B., and Crowley, N.C. (1967). Investigation of suspected grapevine viruses in South Australia. *Australian Journal of Agricultural Research* **18**, 461-466.
- Frisvad, J.C., and Filtenborg, O. (1983). Classification of terverticillate *Penicillia* based on profiles of mycotoxins and other secondary metabolites. *Applied and Environmental Microbiology* **46**, 1301-1310.
- Gemrich, A.R., Link, G., and Seidel, M. (1993). Detection of grapevine fanleaf virus (GFLV) in infected grapevines by non-radioactive nucleic acid hybridisation. *Vitis* **32**, 237-242.
- Gendloff, E.H., Ramsdell, D.C., and Burton, C.L. (1983). Fluorescent antibody studies with *Eutypa armeniacae*. *Phytopathology* **73**, 760-764.
- Ghisalberti, E.L., and Rowland, C.Y. (1993). 6-Chlorodehydrocurvularin, a new metabolite from *Cochliobolus spicifer*. *Journal of Natural Products* **56**, 2175-2177.
- Glawe, D.A., Skotland, C.B., and Moller, W.J. (1982). Isolation and identification of *Eutypa armeniacae* from diseased grapevines in Washington state. *Mycotaxon* **16**, 123-132.
- Gonzalez, M., Rodriguez, R., Zavala, M.E., Jacobo, J.L., Hernandez, F., Acosta, J., Martinez, O., and Simpson, J. (1998). Characterisation of Mexican isolates of *Colletotrichum lindemuthianum* by using differential cultivars and molecular markers. *Phytopathology* **88**, 292-299.

- Goodman, B.A., Williamson, B., and Chudek, J.A. (1992). Non-invasive observation of the development of fungal infection in fruit. *Protoplasma* **166**, 1-2.
- Graham, J.H., Timmer, L.W., Drouillard, D.L., and Peever, T.L. (1998). Characterisation of *Phytophthora* spp. causing outbreaks of citrus brown rot in Florida. *Phytopathology* **88**, 724-729.
- Gramss, G. (1991). Definitive senescence in stock cultures of basidiomycetous wood-decay fungi. *Journal of Basic Microbiology* **31**, 107-112.
- Green, M.J., Thompson, D.A., and MacKenzie, D.J. (1999). Easy and efficient DNA extraction from woody plants for the detection of phytoplasmas by polymerase chain reaction. *Plant Disease* **83**, 482-485.
- Groenewald, M., Bellstedt, D.U., and Crous, P.W. (2000). A PCR-based method for the detection of *Phaeoemoniella chlamydospora* in grapevines. *South African Journal of Science* **96**, 43-46.
- Grunstein, M., and Hogness, D.S. (1975). Colony hybridisation: a method for the isolation of cloned DNAs that contain a specific gene. *Proceedings of the National Academy of Sciences USA* **72**, 3961-3965.
- Guillén, P., Guis, M., Martinez-Reina, G., Colrat, S., Dalmayrac, S., Deswarte, C., Bouzayen, M., Roustan, J.P., Fallot, J., Pech, J.C., and Latché, A. (1998). A novel NADPH-dependent aldehyde reductase gene from *Vigna radiata* confers resistance to the grapevine fungal toxin eutypine. *The Plant Journal* **16**, 335-343.
- Haemmerli, U.A., Brandle, U., Petrini, O., and McDermott, J.M. (1992). Differentiation of isolates of *Discula umbrinella* (teleomorph *Apiognomonium errabunda*) from beech, chestnut and oak using randomly amplified polymorphic DNA markers. *Molecular Plant-Microbe Interactions* **5**, 479-483.
- Hahn, F. (2002). Fungal spore detection on tomatoes using spectral fourier signals. *Biosystems Engineering* **81**, 249-259.
- Hawksworth, D.L., Kirk, P.M., Sutton, B.C., and Pegler, D.N. (1995). "Ainsworth and Bisby's Dictionary of the Fungi," 8th/Ed. CAB International, Wallingford, Oxford, U.K.
- Henson, J.M., and French, R. (1993). The polymerase chain reaction and plant disease diagnosis. *Annual Review of Phytopathology* **31**, 81-109.
- Herdina, Harvey, P., and Ophel-Keller, K. (1996). Quantification of *Gaeumannomyces graminis* var. *tritici* in infected roots and soil using slot-blot hybridisation. *Mycological Research* **100**, 962-970.

- Herdina, Yang, H.A., and Ophel-Keller, K. (1997). Correlation of take-all disease severity and inoculum level of *Gaeumannomyces graminis* var. *tritici* using a slot-blot hybridisation assay. *Mycological Research* **101**, 1311-1317.
- Herrmann, M., Zoicher, R., and Haese, A. (1996). Enniatin production by *Fusarium* strains and its effect on potato tuber tissue. *Applied and Environmental Microbiology* **62**, 393-398.
- Highet, A., and Wicks, T. (1998). The incidence of *Eutypa* dieback in South Australian vineyards. *The Australian Grapegrower and Winemaker* **413**, 135-136.
- Hirsch, P.R., Mauchline, T.H., Mendum, T.A., and Kerry, B.R. (2000). Detection of the nematophagous fungus *Verticillium chlamydosporium* in nematode-infested plant roots using PCR. *Mycological Research* **104**, 435-439.
- Hughes, G., Munkvold, G.P., and Samita, S. (1998). Application of the logistic-normal-binomial distribution to the analysis of *Eutypa* dieback disease incidence. *International Journal of Pest Management*. **44**, 35-42.
- Irelan, N., Gubler, D., and DeScenzo, R. (1999). Efficacy testing of *Eutypa*: chemical and biological control candidates with DNA-based diagnostics. *Practical Winery and Vineyard* **19**, 47-56.
- Ishibashi, K., Nose, K., Shindo, T., Arai, M., and Mishima, H. (1968). Siccayne: Acetylenic metabolite of *Helminthosporium siccans*. *Sankyo Kenkyusho Nempo* **20**, 76-79.
- Ito, S., Nakamura, T., Matsumoto, T., Maehara, T., Tanaka, S., Kameya-Iwaki, M., and Kishi, F. (1998). Characterisation of DNA sequences cloned from resting spores of *Plasmodiophora brassicae*. *Journal of Phytopathology* **146**, 143-147.
- John, S. (2003). Biological control of *Eutypa lata*: Interactions between the pathogen and the antagonists. PhD thesis, The University of Adelaide, Australia.
- John, S., Scott, E.S., Wicks, T.J., and Hunt, J.S. (2003). Studies of interactions between *Eutypa lata* and *Trichoderma harzianum*. In conference proceedings "4<sup>th</sup> International Workshop on Grapevine Trunk Diseases", pp. 33, Lincoln University, New Zealand.
- Ju, Y.M., Glawe, D.A., and Rogers, J.D. (1991). Conidial germination in *Eutypa armeniacae* and selected other species of Diatrypaceae: implications for the systematics and biology of diatrypaceous fungi. *Mycotaxon* **41**, 311-320.
- Judelson, H.S., and Messenger-Routh, B. (1996). Quantitation of *Phytophthora cinnamomi* in avocado roots using a species-specific DNA probe. *Phytopathology* **86**, 763-768.

- Kelemu, S., Dongyi, H., Guixiu, H., and Takayama, Y. (2003). Detecting and differentiating *Acremonium implicatum*: developing a PCR-based method for an endophytic fungus associated with the genus *Brachiaria*. *Molecular Plant Pathology* **4**, 115-118.
- Kerssies, A., Everink, A., Hornstra, L., and van Telgen, H.J. (1994). Electrophoretic detection method for *Fusarium oxysporum* species in cyclamen and carnation by using isozymes. In "Modern Assays for Plant Pathogenic Fungi: Identification, Detection and Quantification" (Schots, A., Dewey, F.M. and Oliver, R., eds.), pp. 57-62. CAB International, Wallingford, Oxford, U.K.
- Kim, C.S., Lee, C.H., Shin, J.S., Chung, Y.S., and Hyung, N.I. (1997). A simple and rapid method for isolation of high quality genomic DNA from fruit trees and conifers using PVP. *Nucleic Acids Research* **25**, 1085-1086.
- Koch, C.A., and Utkhede, R. (2002). Diagnosis and identification of *Didymella bryoniae*, causal agent of gummy stem blight of greenhouse cucumbers, using a dot blot technique. *Journal of Horticultural Science and Biotechnology* **77**, 62-66.
- Koonjul, P.K., Brandt, W.F., Farrant, J.M., and Lindsey, G.G. (1999). Inclusion of polyvinylpyrrolidone in the polymerase chain reaction reverses the inhibitory effects of polyphenolic contamination of RNA. *Nucleic Acids Research* **27**, 915-916.
- Koopmann, B., Karlovsky, P., and Wolf, G. (1994). Differentiation between *Fusarium culmorum* and *Fusarium graminearum* by RFLP and with species-specific DNA Probes. In "Modern Assays for Plant Pathogenic Fungi: Identification, Detection and Quantification" (Schots, A., Dewey, F.M. and Oliver, R., eds.), pp. 37-46. CAB International, Wallingford, Oxford, U.K.
- Kouyeas, H., Chitzanidis, A., Pappas, A., and Carter, M.V. (1976). *Eutypa armeniaca* on apricot and grapevine in Greece. *Phytopathologische Zeitschrift* **87**, 260-263.
- Krokene, P., and Solheim, H. (2001). Loss of pathogenicity in the blue-stain fungus *Ceratocystis polonica*. *Plant Pathology* **50**, 497-502.
- Kupka, J., Anke, T., Steglich, W., and Zechlin, L. (1981). Antibiotics from basidiomycetes. XI. The biological activity of siccayne, isolated from the marine fungus *Halocyphina villosa*. *Journal of Antibiotics* **34**, 298-304.
- Lardner, R., Johnston, P.R., Plummer, K.M., and Pearson, M.N. (1999). Morphological and molecular analysis of *Colletotrichum acutatum sensu lato*. *Mycological Research* **103**, 275-285.

- Leal, S.C.M., Bertioli, D.J., Butt, T.M., and Peberdy, J.F. (1994). Characterisation of isolates of the entomopathogenic fungus *Metarhizium anisopliae* by RAPD PCR. *Mycological Research* **98**, 1077-1081.
- Leavitt, G. (2003). The occurrence, distribution, effects and control of *Botryodiplodia theobromae* on *Vitis vinifera* in California, Arizona and Northern Mexico. In *conference proceedings "4<sup>th</sup> International workshop on grapevine trunk diseases"*, pp. 30, Lincoln University, New Zealand.
- Lebrun, M.H., Dutfoy, F., Gaudemer, F., Kunesch, G., and Gaudemer, A. (1990). Detection and quantification of the fungal phytotoxin tenuazonic acid produced by *Pyricularia oryzae*. *Phytochemistry* **29**, 3777-3782.
- Leclerc-Potvin, C., Balmas, V., Charest, P.M., and Jabaji-Hare, S. (1999). Development of reliable molecular markers to detect non-pathogenic binucleate *Rhizoctonia* isolates (AG-G) using PCR. *Mycological Research* **103**, 1165-1172.
- Lecomte, P., Péros, J.P., Blancard, D., Bastien, N., and Délye, C. (2000). PCR assays that identify the grapevine dieback fungus *Eutypa lata*. *Applied and Environmental Microbiology* **66**, 4475-4480.
- Li, J.-Y., Sidhu, R.S., Bollon, A., and Strobel, G.A. (1998). Stimulation of taxol production in liquid cultures of *Pestalotiopsis microspora*. *Mycological Research* **102**, 461-464.
- Li, K.-N., Rouse, D.I., Eyestone, E.J., and German, T.L. (1999). The generation of specific DNA primers using random amplified polymorphic DNA and its application to *Verticillium dahliae*. *Mycological Research* **103**, 1361-1368.
- Link, W., Dixens, C., Singh, M., Schwall, M., and Melchinger, A.E. (1995). Genetic diversity in European and Mediterranean faba bean germ plasm revealed by RAPD markers. *Theoretical and Applied Genetics* **90**, 27-32.
- Lodhi, M.A., Ye, G.-N., Weeden, N.F., and Reisch, B.I. (1994). A simple and efficient method for DNA extraction from grapevine cultivars and *Vitis* species. *Plant Molecular Biology Reporter* **12**, 6-13.
- Long, P.G., Nicoll, C.L., Davis, L.K., and Bradshaw, R.E. (2003). Producing the sexual stage of *Eutypa lata* *in vivo* and characterising parents and progeny. In *conference proceedings "4<sup>th</sup> International Workshop on Grapevine Trunk Diseases"*, pp. 14, Lincoln University, New Zealand.
- Luz, J.M., Paterson, R.R.M., and Brayford, D. (1990). Fusaric acid and other metabolite production in *Fusarium oxysporum* f. sp. *vasinfectum*. *Letters in Applied Microbiology* **11**, 141-144.



- Magarey, P.A., and Carter, M.V. (1986). New technology facilitates control of *Eutypa* dieback in apricots and grapevines. *Plant Protection Quarterly* **1**, 156-159.
- Mahoney, N., Lardner, R., Molyneux, R.J., Scott, E.S., Smith, L.R., and Schoch, T.K. (2003). Phenolic metabolite profiles of the grapevine pathogen *Eutypa lata*. *Phytochemistry* **in press**.
- Majer, D., Mithen, R., Lewis, B.G., Vos, P., and Oliver, R.P. (1996). The use of AFLP fingerprinting for the detection of genetic variation in fungi. *Mycological Research* **100**, 1107-1111.
- Manning, K. (1991). Isolation of nucleic acids from plants by differential solvent precipitation. *Analytical Biochemistry* **195**, 45-50.
- Masuch, G., Franz, J.T., Marshmann, H., Gross, D., and Kettrup, A. (1991). <sup>1</sup>H-NMR micro-imaging and correlated SEM studies of spruce needles from healthy and declined forest sites. *International Journal of Environmental and Analytical Chemistry* **45**, 179-191.
- Mathur, S., and Utkhede, R. (2002). Development of a dot blot technique for rapid identification of *Botrytis cinerea*, the causal agent of grey mould in greenhouse tomatoes. *Journal of Horticultural Science and Biotechnology* **77**, 604-608.
- Matthew, J., Herdina, and Whisson, D. (1995). DNA probe specific to *Rhizoctonia solani* anastomosis group 8. *Mycological Research* **99**, 745-750.
- Mauro, M.C., Vaillant, V., Tey-Rulh, P., Mathieu, Y., and Fallot, J. (1988). *In vitro* study of the relationship between *Vitis vinifera* and *Eutypa lata* (Pers.: Fr.) Tul. I. Demonstration of toxic compounds secreted by the fungus. *American Journal of Enology and Viticulture* **39**, 200-204.
- McDermott, J.M., Brändle, U., Dutly, F., Haemmerli, U.A., Keller, S., Müller, K.E., and Wolfe, M.S. (1994). Genetic variation in powdery mildew of barley: development of RAPD, SCAR, and VNTR markers. *Phytopathology* **84**, 1316-1321.
- McMahan, G., Yeh, W., Marshall, M.N., Olsen, M., Sananikone, S., Wu, J.Y., Block, D.E., and VanderGheynst, J.S. (2001). Characterising the production of a wild-type and benomyl-resistant *Fusarium lateritium* for biocontrol of *Eutypa lata* on grapevine. *Journal of Industrial Microbiology and Biotechnology* **26**, 151-155.
- Meinkoth, J., and Wahl, G. (1984). Hybridisation of nucleic acids immobilised on solid supports. *Analytical Biochemistry* **138**, 267-284.

- Melanson, D.L., Rawnsley, B., and Scheper, R.W.A. (2002). Molecular detection of *Phomopsis* taxa 1 and 2 in grapevine canes and buds. *Australasian Plant Pathology* **31**, 67-73.
- Messing, J. (1983). New M13 vectors for cloning. *Methods in Enzymology* **101**, 20-78.
- Michelmore, R.W., and Hulbert, S.H. (1987). Molecular markers for genetic analysis of phytopathogenic fungi. *Annual Review of Phytopathology* **25**, 383-404.
- Miller, S.A., and Martin, R.R. (1988). Molecular diagnosis of plant disease. *Annual Review of Phytopathology* **26**, 409-432.
- Minsavage, G.V., Thompson, C.M., Hopkins, D.L., Leite, R.M.V.B.C., and Stall, R.E. (1994). Development of a polymerase chain reaction protocol for detection of *Xylella fastidiosa* in plant tissue. *Phytopathology* **84**, 456-461.
- Moller, W.J., Braun, A.J., Uyemoto, J.K., and Kasimatis, A.N. (1977). *Eutypa armeniacae* inoculum associated with dead arm-affected grapevines in New York and Ontario. *Plant Disease Reporter* **61**, 422-423.
- Moller, W.J., and Carter, M.V. (1965). Production and dispersal of ascospores in *Eutypa armeniacae*. *Australian Journal of Biological Sciences* **18**, 67-80.
- Moller, W.J., and Carter, M.V. (1969). A preliminary observation on apricot dieback prevention with chemicals. *Plant Disease Reporter* **53**, 828-829.
- Moller, W.J., and Kasimatis, A.N. (1978). Dieback of grapevines caused by *Eutypa armeniacae*. *Plant Disease Reporter* **62**, 254-258.
- Moller, W.J., and Kasimatis, A.N. (1980). Protection of grapevine pruning wounds from eutypa dieback. *Plant Disease* **64**, 278-280.
- Moller, W.J., and Kasimatis, A.N. (1981). Further evidence that *Eutypa armeniacae* - not *Phomopsis viticola* incites dead arm symptoms on grape. *Plant Disease* **65**, 429-431.
- Moller, W.J., Kasimatis, A.N., and Kissler, J.J. (1974). A dying arm disease of grape in California. *Plant Disease Reporter* **58**, 869-871.
- Moller, W.J., and Lehoczky, J. (1980). The occurrence of Eutypa dieback of grapevine in Hungary. *Phytopathologische Zeitschrift* **99**, 116-125.
- Molyneux, R.J., Mahoney, N., Bayman, P., Wong, R.Y., Meyer, K., and Irelan, N. (2002). Eutypa dieback in grapevines: Differential production of acetylenic phenol metabolites by strains of *Eutypa lata*. *Journal of Agricultural and Food Chemistry* **50**, 1393-1399.
- Morgan, M.R.A. (1995). Monitoring safety of plant foods: Immunodiagnosics for mycotoxins and other bioactive compounds. In "New Diagnostics in Crop

- Sciences" (Skerritt, J.H. and Appels, R., eds.), pp. 215-242. CAB International, Wallingford, Oxford, U.K.
- Mostert, L., Crous, P.W., Kang, J.-C., and Phillips, A.J.L. (2001). Species of *Phomopsis* and a *Libertella* sp. occurring on grapevines with special reference to South Africa: morphological, cultural, molecular and pathological characterisation. *Mycologia* **95**, 146-167.
- Mulé, G., Logrieco, A., Stea, G., and Bottalico, A. (1997). Clustering of trichothecene-producing *Fusarium* strains determined from 28S ribosomal DNA sequences. *Applied and Environmental Microbiology* **63**, 1843-1846.
- Munkvold, G.P., Duthie, J.A., and Marois, J.J. (1992). Relationship of *Eutypa dieback* severity to growth and yield of grapevines. *Phytopathology* **82**, 1084.
- Munkvold, G.P., Duthie, J.A., and Marois, J.J. (1993). Spatial patterns of grapevines with *Eutypa dieback* in vineyards with or without perithecia. *Phytopathology* **83**, 1440-1448.
- Munkvold, G.P., and Marois, J.J. (1991). Perithecia of *Eutypa lata* on sweet cherry in the central valley of California. *Plant Disease* **75**, 431.
- Munkvold, G.P., and Marois, J.J. (1993a). Efficacy of natural epiphytes and colonisers of grapevine pruning wounds for biological control of *Eutypa dieback*. *Phytopathology* **83**, 624-629.
- Munkvold, G.P., and Marois, J.J. (1993b). The effects of fungicides on *Eutypa lata* germination, growth, and infection of grapevines. *Plant Disease* **77**, 50-55.
- Munkvold, G.P., and Marois, J.J. (1994). *Eutypa dieback* of sweet cherry and occurrence of *Eutypa lata* perithecia in the Central Valley of California. *Plant Disease* **78**, 200-207.
- Munkvold, G.P., and Marois, J.J. (1995). Factors associated with variation in susceptibility of grapevine pruning wounds to infection by *Eutypa lata*. *Phytopathology* **85**, 249-256.
- Muralidharan, K., and Wakeland, E.K. (1993). Concentration of primer and template qualitatively affects products in random-amplified polymorphic DNA. *Bio Techniques* **14**, 362-364.
- Nei, M., and Li, W.H. (1979). A mathematical model for studying genetic variation in terms of restriction endonucleases. *Proceedings of the National Academy of Sciences USA* **76**, 5269-5273.
- Nyasse, S., Grivet, L., Risterucci, A.M., Blaha, G., Berry, D., Lanaud, C., and Despreaux, D. (1999). Diversity of *Phytophthora megakarya* in Central and

- West Africa revealed by isozyme and RAPD markers. *Mycological Research* **103**, 1225-1234.
- Ouellet, T., and Seifert, K.A. (1993). Genetic characterisation of *Fusarium graminearum* strains using RAPD and PCR amplification. *Phytopathology* **83**, 1003-1007.
- Paran, I., and Michelmore, R.W. (1993). Development of reliable PCR-based markers linked to downy mildew resistance genes in lettuce. *Theoretical and Applied Genetics* **85**, 985-993.
- Pascoe, I. (1999). Grapevine trunk diseases - black goo decline, esca, Eutypa dieback and others. *The Australian Grapegrower and Winemaker* **429**, 24-28.
- Pastrik, K.H. (2000). Detection of *Clavibacter michiganensis* subsp. *sepedonicus* in potato tubers by multiplex PCR with co-amplification of host DNA. *European Journal of Plant Pathology* **106**, 155-165.
- Pearson, R.C., and Burr, T.J. (1981). Grape IPM Disease Identification Sheet No. 1. New York State Agriculture Experimental Station, Geneva, U.S.A.
- Penner, G.A., Bush, A., Wise, R., Kim, W., Domier, L., Kasha, L., Laroche, A., Scoles, G., Molnar, S.J., and Fedak, G. (1993). Reproducibility of random amplified polymorphic DNA (RAPD) analysis among laboratories. *PCR Methods and Applications* **2**, 341-345.
- Péros, J.P., and Berger, G. (1999). Diversity within natural progenies of the grapevine dieback fungus *Eutypa lata*. *Current Genetics* **36**, 301-309.
- Péros, J.P., Berger, G., and Lahogue, F. (1997). Variation in pathogenicity and genetic structure in the *Eutypa lata* population of a single vineyard. *Phytopathology* **87**, 799-806.
- Péros, J.P., Jamaux-Despréaux, I., Berger, G., and Gerba, D. (1999). The potential importance of diversity in *Eutypa lata* and co-colonising fungi in explaining variation in development of grapevine dieback. *Mycological Research* **103**, 1385-1390.
- Péros, J.P., and Larignon, P. (1998). Confirmation of random mating and indication for gene flow in the grapevine dieback fungus, *Eutypa lata*. *Vitis* **37**, 97-98.
- Péros, J.P., This, P., Confuron, Y., and Chacon, H. (1996). Comparison by isozyme and RAPD analysis of some isolates of the grapevine dieback fungus, *Eutypa lata*. *American Journal of Enology and Viticulture* **47**, 49-56.

- Petzoldt, C.H., Moller, W.J., and Sall, M.A. (1981). Eutypa dieback of grapevine: seasonal differences in infection and duration of susceptibility of pruning wounds. *Phytopathology* **71**, 540-543.
- Petzoldt, C.H., Sall, M.A., and Moller, W.J. (1983). Eutypa dieback of grapevines: Ascospore dispersal in California. *American Journal of Enology and Viticulture* **34**, 265-270.
- Pezet, R. (1983). "Rapid spore production by *Cytosporina* sp. on a synthetic medium and production of a toxin-like product." Station Federale de Changins, Suisse.
- Pfeffer, P.E., Douds, D.D., Bécard, G., and Shachar-Hill, Y. (1999). Carbon uptake and the metabolism and transport of lipids in an arbuscular mycorrhiza. *Plant Physiology* **120**, 587-598.
- Pillay, M., and Kenny, S.T. (1995). Anomalies in direct pairwise comparisons of RAPD fragments for genetic analysis. *Bio Techniques* **19**, 694-698.
- Pipe, N.D., Buck, K.W., and Brasier, C.M. (1995). Molecular relationships between *Ophiostoma ulmi* and the NAN and EAN races of *O. novo-ulmi* determined by RAPD markers. *Mycological Research* **99**, 653-658.
- Pomp, D., and Medrano, J.F. (1991). Organic solvents as facilitators of polymerase chain reaction. *Bio Techniques* **10**, 58-59.
- Rahbaek, L., Frisvad, J.C., and Christophersen, C. (2000). An amendment of *Aspergillus* section *Candidi* based on chemotaxonomical evidence. *Phytochemistry* **53**, 581-586.
- Raikes, C., and Burpee, L.L. (1998). Use of multispectral radiometry for assessment of Rhizoctonia blight in creeping bentgrass. *Phytopathology* **88**, 446-449.
- Ramos, D.E., Moller, W.J., and English, H. (1975). Production and dispersal of ascospores of *Eutypa armeniacae* in California. *Phytopathology* **65**, 1364-1371.
- Rappaz, F. (1984). The sanctioned species of the genus *Eutypa* (*Diatrypaceae*: Ascomycetes): Taxonomic and nomenclatural study. *Mycotaxon* **20**, 567-586.
- Reddick, D. (1909). Necrosis of the grapevine. *New York Agricultural Station Bulletin* **263**, 323-343.
- Renaud, J.M., Tsoupras, G., Stoeckli-Evans, H., and Tabacchi, R. (1989a). A novel allenic epoxy cyclohexane and related compounds from *Eutypa lata* (Pers:Fr.) Tul. *Helvetica Chimica Acta* **72**, 1262-1267.
- Renaud, J.M., Tsoupras, G., and Tabacchi, R. (1989b). Biologically active natural acetylenic compounds from *Eutypa lata* (Pers:Fr.) Tul. *Helvetica Chimica Acta* **72**, 929-932.

- Ridgway, H.J., Sleight, B.E., and Stewart, A. (2002). Molecular evidence for the presence of *Phaeoconiella chlamydospora* in New Zealand nurseries, and its detection in rootstock mothervines using species-specific PCR. *Australasian Plant Pathology* **31**, 267-271.
- Rolph, H., Wijesekara, R., Lardner, R., Abdullah, F., Kirk, P.M., Bridge, P.D., and Flood, J. (2000). Molecular variation in *Ganoderma* isolates from oilpalm, coconut and betelnut. In "Ganoderma diseases of perennial crops" (Flood, J. Holderness, M. and Bridge, P.D., eds.), pp. 205-221. CABI Bioscience, Royal Botanic Gardens, Kew, Richmond, U.K.
- Rosendahl, S., and Taylor, J.W. (1997). Development of multiple genetic markers for studies of genetic variation in arbuscular mycorrhizal fungi using AFLP. *Molecular Ecology* **6**, 821-829.
- Rott, M.E., and Jelkmann, W. (2001). Characterisation and detection of several filamentous viruses of cherry: Adaptation of an alternative cloning method (DOP-PCR), and modification of an RNA extraction protocol. *European Journal of Plant Pathology* **107**, 411-420.
- Roustan, J.P., Colrat, S., Dalmayrac, S., Guillen, P., Guis, M., Martinez-Reina, G., Deswarte, C., Bouzayen, M., Fallot, J., Pech, J.C., Latché, A., Bouquet, A., and Boursiquot, J.M. (2000). Eutypa dieback of grapevine: expression of an NADPH-dependent aldehyde reductase which detoxifies eutypine, a toxin from *Eutypa lata*. In "Proceedings of the Seventh International Symposium on Grapevine Genetics and Breeding". *Acta Horticulturae* **528**, 329-336.
- Ryan, M.J., Jeffries, P., Bridge, P.D., and Smith, D. (2001). Developing cryopreservation protocols to secure fungal gene function. *Cryoletters* **22**, 115-124.
- Saiki, R.K., Gelfand, D.H., Stoffel, S., Scharf, S.J., Higuchi, R., Horn, G.T., Mullis, K.B., and Erlich, H.A. (1988). Primer-directed enzymatic amplification of DNA with a thermostable DNA polymerase. *Science* **239**, 487-491.
- Saiki, R.K., Scharf, S.J., Faloona, F., Mullis, K.B., Horn, G.T., Erlich, H.A., and Arnheim, N. (1985). Enzymatic amplification of  $\beta$ -globin genomic sequences and restriction site analysis for diagnosis of sickle cell anaemia. *Science* **230**, 1350-1354.
- Salazar, O., Jullian, M.C., and Rubio, V. (2000). Primers based on specific rDNA-ITS sequences for PCR detection of *Rhizoctonia solani*, *R. solani* AG 2 subgroups

- and ecological types, and binucleate *Rhizoctonia*. *Mycological Research* **104**, 281-285.
- Salinas, J., Schober, G., and Schotts, A. (1994). Monoclonal antibodies for detection of conidia of *Botrytis cinerea* on cut flowers using an immunofluorescence assay. In "Modern Assays for Plant Pathogenic Fungi: Identification, Detection and Quantification" (Schots, A., Dewey, F.M. and Oliver, R., eds.), pp. 173-179. CAB International, Wallingford, Oxford, U.K.
- Sambrook, J., Fritsch, E.F., and Maniatis, T.A. (1989). "Molecular cloning: A laboratory manual," 2nd/Ed. Cold Spring Harbor Laboratory Press, Cold Spring Harbor, N.Y., U.S.A.
- Samuel, G. (1933). Untitled Report. *Journal of the Department of Agriculture of South Australia* **36**, 979-980.
- Santos, I.M., Abrunhosa, L., Venâncio, A., and Lima, N. (2002). The effect of culture preservation techniques on patulin and citrinin production by *Penicillium expansum* Link. *Letters in Applied Microbiology* **35**, 272-275.
- Schaad, N.W. (1979). Serological identification of plant pathogenic bacteria. *Annual Review of Phytopathology* **17**, 123-147.
- Schesser, K., Luder, A., and Henson, J.M. (1991). Use of polymerase chain reaction to detect the take-all fungus, *Gaeumannomyces graminis*, in infected wheat plants. *Applied and Environmental Microbiology* **57**, 553-556.
- Schilling, A.G., Möller, E.M., and Geiger, H.H. (1996). Polymerase chain reaction-based assays for species-specific detection of *Fusarium culmorum*, *F. graminearum*, and *F. avenaceum*. *Phytopathology* **86**, 515-522.
- Schmidt, C.S., Lorenz, D., and Wolf, G.A. (2001a). Biological control of the grapevine dieback fungus *Eutypa lata* I: screening of bacterial antagonists. *Journal of Phytopathology* **149**, 427-435.
- Schmidt, C.S., Lorenz, D., Wolf, G.A., and Jäger, J. (2001b). Biological control of the grapevine dieback fungus *Eutypa lata* II: influence of formulation additives and transposon mutagenesis on the antagonistic activity of *Bacillus subtilis* and *Erwinia herbicola*. *Journal of Phytopathology* **149**, 437-445.
- Schmidt, C.S., Wolf, G.A., and Lorenz, D. (1999). Production of extracellular hydrolytic enzymes by the grapevine dieback fungus *Eutypa lata*. *Zeitschrift fuer Pflanzenkrankheiten und Pflanzenschutz* **106**, 1-11.

- Schnieder, F., Koch, G., Jung, C., and Verreet, J.A. (1998). The application of molecular markers for genetic characterisation of *Septoria tritici* populations. *Zeitschrift für Pflanzenkrankheiten und Pflanzenschutz* **105**, 452-461.
- Siebert, J.B. (2000). "Economic impact of Eutypa on the California Wine Grape Industry," Report prepared for the American Vineyard Foundation.
- Skerritt, J.H., and Appels, R. (1995). An overview of the development and application of diagnostic methods in crop sciences. In "New Diagnostics in Crop Sciences" (Skerritt, J.H. and Appels, R., eds.), pp. 1-33. CAB International, Wallingford, Oxford, U.K.
- Smith, A.L. (1900). Some new microscopic fungi. *Journal of the Microscopical Society*, 422-424.
- Smith, J.J., Scott-Craig, J.S., Leadbetter, J.R., Bush, G.L., Roberts, D.L., and Fulbright, D.W. (1994). Characterisation of random amplified polymorphic DNA (RAPD) products from *Xanthomonas campestris* and some comments on the use of RAPD products in phylogenetic analysis. *Molecular Phylogenetics and Evolution* **3**, 135-145.
- Smith, L.R., Mahoney, N., and Molyneux, R.J. (2003). Synthesis and structure-phytotoxicity relationships of acetylenic phenols and chromene metabolites, and their analogues, from the grapevine pathogen *Eutypa lata*. *Journal of Natural Products* **66**, 169-176.
- Soulie, O., Roustan, J.P., and Fallot, J. (1993). Early *in vitro* selection of eutypine-tolerant plantlets: Application to screening of *Vitis vinifera* cv. Ugni Blanc somaclones. *Vitis* **32**, 243-244.
- Southern, E.M. (1975). Detection of specific sequences among DNA fragments separated by gel electrophoresis. *Journal of Molecular Biology* **98**, 503-517.
- Sparapano, L., Bruno, G., and Graniti, A. (2000). Effects on plants of metabolites produced in culture by *Phaeoacremonium chlamydosporum*, *P. aleophilum* and *Fomitiporia punctata*. *Phytopathologia Mediterranea* **39**, 169-177.
- Stadler, M., Wollweber, H., Muhlbauer, A., Asakawa, Y., Hashimoto, T., Rogers, J.D., Ju, Y.-M., Wetzstein, H.-G., and Tichy, H.-V. (2001). Molecular chemotaxonomy of *Daldinia* and other *Xylariaceae*. *Mycological Research* **105**, 1191-1205.
- Strasser, H., Abendstein, D., Stuppner, H., and Butt, T.M. (2000). Monitoring the distribution of secondary metabolites produced by the entomogenous fungus



- Beauveria brongniartii* with particular reference to oosporein. *Mycological Research* **104**, 1227-1233.
- Stummer, B.E., Zanker, T., Scott, E.S., and Whisson, D.L. (2000). Genetic diversity in populations of *Uncinula necator*: comparison of RFLP- and PCR-based approaches. *Mycological Research* **104**, 44-52.
- Tabacchi, R. (1994). Secondary phytotoxic metabolites from pathogenic fungi: Structure, synthesis and activity. *Pure and Applied Chemistry* **66**, 2299-2302.
- Tabacchi, R., Fkyerat, A., Poliart, C., and Dubin, G.M. (2000). Phytotoxins from fungi of esca of grapevine. *Phytopathologia Mediterranea* **39**, 156-161.
- Tebbe, C.C., and Vahjen, W. (1993). Interference of humic acids and DNA extracted directly from soil in detection and transformation of recombinant DNA from bacteria and a yeast. *Applied and Environmental Microbiology* **59**, 2657-2665.
- Tey Rulh, P., Philippe, I., Renaud, J.M., Tsoupras, G., de Angelis, P., Roustan, J.P., Fallot, J., and Tabacchi, R. (1991). Eutypine, a phytotoxin produced by *Eutypa lata* the causal agent of dying-arm disease of grapevine. *Phytochemistry* **30**, 471-473.
- Thompson, J.D., Higgins, D.G., and Gibson, T.J. (1994). CLUSTAL W: Improving the sensitivity of progressive multiple sequence alignment through sequence weighting, position-specific gap penalties and weight matrix choice. *Nucleic Acids Research* **22**, 4673-4680.
- Thornton, C.R., Dewey, F.M., and Gilligan, C.A. (1994). Development of monoclonal antibody-based immunological assays for the detection of live propagules of *Rhizoctonia solanii* in the field. In "Modern Assays for Plant Pathogenic Fungi: Identification, Detection and Quantification" (Schots, A., Dewey, F.M. and Oliver, R., eds.), pp. 29-37. CAB International, Wallingford, Oxford, U.K.
- Tran-Dinh, N., Pitt, J.I., and Carter, D.A. (1999). Molecular genotype analysis of natural toxigenic and nontoxigenic isolates of *Aspergillus flavus* and *A. parasiticus*. *Mycological Research* **103**, 1485-1490.
- Trouillas, F.P., Rolshausen, P.E., and Gubler, W.D. (2001). Importance of *Eutypa lata* and occurrence of other Diatrypaceous fungi in Northern California vineyards. In "2001 APS/MSA/SON Joint meeting abstracts" American Phytopathological Society, San Jose, California, [www.apsnet.org/meetings/2001](http://www.apsnet.org/meetings/2001)
- Trouillas, F.P., Rolshausen, P.E., and Gubler, W.D. (2002). Discovery of a second *Eutypa* species pathogenic to grapevine in California. In "2002 Pacific division

- meeting abstracts, June 22-24", American Phytopathological Society, San Jose, California.
- Tsoupras, G., De Angelis, P., Zesiger, T., Renaud, J.M., and Tabacchi, R. (1988). Biologically active natural acetylenes from the culture medium of *Eutypa lata*. In "Bioactive Molecules: Chemistry and biology of naturally occurring acetylenes and related compounds (NOARC)" (Lam, J., Breteler, H., Arnason, T. and Hansen, L., eds.), Vol. 7, pp. 93-100. Elsevier, Aarhus, Denmark.
- van de Koppel, M.M., and Schots, A. (1994). A double (monoclonal) antibody sandwich ELISA for the detection of *Verticillium* species in roses. In "Modern Assays for Plant Pathogenic Fungi: Identification, Detection and Quantification" (Schots, A., Dewey, F.M. and Oliver, R., eds.), pp. 99-104. CAB International, Wallingford, Oxford, U.K.
- Van de Peer, Y., and De Wachter, R. (1994). TREECON for Windows: a software package for the construction and drawing of evolutionary trees for the Microsoft Windows environment. *Computer Applications in Bioscience* **10**, 569-570.
- Vidal, J.R., Delavault, P., Coarer, M., and Defontaine, A. (2000). Design of grapevine (*Vitis vinifera* L.) cultivar-specific SCAR primers for PCR fingerprinting. *Theoretical and Applied Genetics* **101**, 1194-1201.
- Vogel, H.J. (1964). Distribution of lysine pathways among fungi: evolutionary implications. *American Naturalist* **98**, 435-446.
- Vos, P., Hogers, R., Bleeker, M., Reijans, M., Van de Lee, T., Hornes, M., Frijters, A., Pot, J., Peleman, J., Kuiper, M., and Zabeau, M. (1995). AFLP: a new technique for DNA fingerprinting. *Nucleic Acids Research* **23**, 4407-4414.
- Walker, J., and Dougan, G. (1989). DNA probes: a new role in diagnostic microbiology. *Journal of Applied Bacteriology* **67**, 229-238.
- Wang, S.Y., Wang, P.C., and Faust, M. (1988). Non-destructive detection of watercore in apple with nuclear magnetic resonance imaging. *Scientia Horticulture* **35**, 227-234.
- Wedge, D.E., Riley, M.B., and Tainter, F.H. (1999). Phytotoxicity of *Discula destructiva* culture filtrates to *Cornus* spp. and the relationship to disease symptomology. *Plant Disease* **83**, 377-380.
- Weiland, J.J., and Sundsbak, J.L. (2000). Differentiation and detection of sugar beet fungal pathogens using PCR amplification of actin coding sequences and the ITS region of the rRNA gene. *Plant Disease* **84**, 475-482.

- Weining, S., and Langridge, P. (1991). Identification and mapping of polymorphisms in cereals based on the polymerase chain reaction. *Theoretical and Applied Genetics* **82**, 209-216.
- Welsh, J., and McClelland, M. (1990). Fingerprinting genomes using PCR with arbitrary primers. *Nucleic Acids Research* **18**, 7213-7218.
- Wetzel, H.C., Skinner, D.Z., and Tisserat, N.A. (1999). Geographic distribution and genetic diversity of three *Ophiosphaerella* species that cause spring dead spot of bermuda grass. *Plant Disease* **83**, 1160-1166.
- Whisson, D.L., Herdina, and Francis, L. (1995). Detection of *Rhizoctonia solani* AG-8 in soil using a specific DNA probe. *Mycological Research* **99**, 1299-1302.
- Whitkus, R., Doebley, J., and Wendel, J.F. (1994). Nuclear DNA markers in systematics and evolution. In "DNA-based markers in plants" (Phillips, R.L. and Vasil, I.K., eds.), pp. 116-139. Kluwer Academic, Dordrecht, Boston.
- Wicks, T.J., and Davies, K. (1999). The effect of Eutypa on grapevine yield. *The Australian Grapegrower and Winemaker* **426**, 15-16.
- Wicks, T.J., and Hall, B. (1997). Eutypa dieback: a serious disease. *The Australian Grapegrower and Winemaker* **405**, 61-62.
- Wilkerson, R.C., Parsons, T.J., Albright, D.G., Klein, T.A., and Braun, M.J. (1993). Random amplified polymorphic DNA (RAPD) markers readily distinguish cryptic mosquito species (Diptera: Culiciade: Anopheles). *Insect Molecular Biology* **1**, 205-211.
- Williams, J.G.K., Kubelik, A.R., Livak, K.J., Rafalski, J.A., and Tingey, S.V. (1990). DNA polymorphisms amplified by arbitrary primers are useful as genetic markers. *Nucleic Acids Research* **18**, 6531-6535.
- Williamson, B., Goodman, B.A., Chudek, J.A., Johnston, D.J., Verhoeff, K., and Malathrakis, N.E. (1992). Nuclear magnetic resonance (NMR) microimaging of soft fruits infected by *Botrytis cinerea*. In "Recent advances in Botrytis research," pp. 140-144. Pudoc Scientific Publishers; Wageningen; Netherlands, Proceedings of the 10th International Botrytis symposium, Heraklion, Crete, Greece.
- Witthuhn, R.C., Wingfield, B.D., Wingfield, M.J., and Harrington, T.C. (1999). PCR-based identification and phylogeny of species of *Ceratocystis sensu stricto*. *Mycological Research* **103**, 743-749.

- Wolf, T. (1996). Untersuchungen an Holz zur Sortenidentifikation von Rebunterlagssorten mit Hilfe der RAPD-Methode, Johannes Gutenberg-Universität Mainz, Mainz, BRD.
- Wolf, T., Eimert, K., and Ries, R. (1999). Reliable identification of grapevine rootstock varieties using RAPD PCR on woody samples. *Australian Journal of Grape and Wine Research* **5**, 34-38.
- Yoshitsugu, S., Barr, J.R., Barr, D.B., Brock, J.W., Elie, C.M., Ueno, Y., Patterson, D.G., Morris, J.R., Potter, M.E., and Reiss, E. (1999). Physiological characteristics and mycotoxins of human clinical isolates of *Fusarium* species. *Mycological Research* **103**, 1462-1468.
- Young, A.B., Davis, N.D., and Diener, U.L. (1980). Effect of temperature and moisture on tenuazonic acid production by *Alternaria tenuissima*. *Phytopathology* **70**, 607-609.
- Zézé, A., Hosny, M., Gianinazzi-Pearson, V., and Dulieu, H. (1996). Characterisation of a highly repeated DNA sequence (SC1) from the arbuscular mycorrhizal fungus *Scutellospora castanea* and its detection *in planta*. *Applied and Environmental Microbiology* **61**, 2443-2448.
- Zézé, A., Hosny, M., Van Tuinen, D., Gianinazzi-Pearson, V., and Dulieu, H. (1999). MYCDIRE, a dispersed repetitive DNA element in arbuscular mycorrhizal fungi. *Mycological Research* **106**, 572-576.
- Zhang, Y.-p., Uyemoto, J.K., and Kirkpatrick, B.C. (1998). A small-scale procedure for extracting nucleic acids from woody plants infected with various phytopathogens for PCR assay. *Journal of Virological Methods* **71**, 45-50.
- Zuckerman, B.M., Dicklow, M.B., Coles, G.C., and Marben-Mendoza, N. (1989). Loss of virulence of the endoparasitic fungus *Drechmeria coniospora* in culture. *Journal of Nematology* **21**, 135-137.