

A Pocket Guide to IPM Scouting in Wild Blueberries 2nd Edition

Compiled and edited by:

David Yarborough
Frank Drummond
Seanna Annis
Jennifer Cote
Alison Dibble

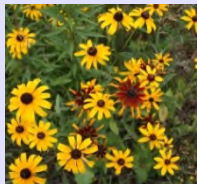
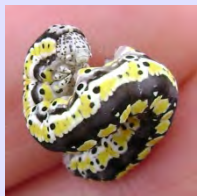
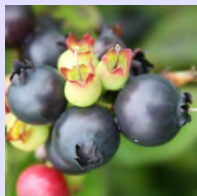

Table of Contents

Using This Scouting Guide	1
Why Use IPM	2
How to Scout.....	3
Tips for Scouting	6
Growth Stages	14
Sections (color-coded for easier identification)	
Diseases	16
Insects	27
(in order of occurrence throughout growing season)	
Natural Enemies.....	45
Bees	50
Weeds	67
Nutrients	89
Herbicide Injury	91
Abiotic Injury.....	95
Factors Affecting Pesticide Drift.....	97
Estimating Wind Speed.....	99

Photo Credits: David Yarborough, Frank Drummond, Seanna Annis, Alison Dibble, Jennifer Cote, Judith Collins, James Dill, Dutch Forsythe, Rufus Isaacs, Beth Choate, Eric Venturini.

Acknowledgements: Design and layout by Phoebe Nylund; Design of bee section by Alison Dibble and Martha Brill.

Using this Scouting Guide

This guide was developed as a pocket reference book for easy use. It is patterned after *A Pocket Guide to IPM Scouting in Highbush Blueberries*, Michigan State University Extension Bulletin E-2928. Since there are significant differences in the growth habit and management of wild lowbush versus cultivated highbush blueberry, this guide was designed to be specific for wild blueberry pests and scouting practices. This guide provides a summary of the information found in the *Wild Blueberry Growers Guide* available on the University of Maine website www.wildblueberries.maine.edu or on CD in Adobe PDF format.

Other Web resources that provide wild blueberry IPM information include:
http://www.dal.ca/sites/wild-blueberry/publications/fact_sheets.html

Why Use IPM

Integrated Pest Management (IPM) is an approach to managing weeds, diseases and insect pests in blueberry fields for the best economic and environmental results. This comes about when the potential cost of crop loss due to pests equals the cost of controlling the pest, NOT by treating fields that have no or extremely low pest densities.

Regular scouting is the foundation for IPM. Detecting pest problems early and accurately will allow you to manage pests and avert crop loss with fewer resources and less environmental impact.

Monitoring insect, disease and weed populations as well as fertility and pH regularly, provides information for making sound pest and nutrient management decisions.

How to Scout

Scouting for pests, diseases and weeds requires monitoring fields on a regular basis and recording your findings. IPM data sheets are available as part of Wild Blueberry Fact Sheet 204, *Integrated Crop Management Field Scouting Guide for Lowbush Blueberries* <http://umaine.edu/blueberries/factsheets/production/integrated-crop-managment-field-scouting-guide-for-lowbush-blueberries/>.

Different insects and diseases require monitoring at different times in the growing season (see scouting chart on page 5 of this guide for major pests and times of appearance).

By understanding the basic biology and life cycles, you will be able to predict when pests are likely to cause damage. This knowledge will allow you to determine when to monitor pest densities to determine if they occur in damaging numbers.

Learn to identify disease, insect and weed life stages and the damage they can cause. Look carefully for disease symptoms after prolonged wet periods.

Develop a field history with locations of areas most affected by pest and disease outbreaks in your field. Draw maps of these high risk areas and monitor them more intensely.

Keep track of weather and pesticide applications to distinguish pest damage and disease from physiological disorders and pesticide injury.

Weather monitoring of minimum-maximum temperatures and precipitation can explain weather related disorders such as cold injury and are used to predict when diseases and blueberry maggot flies will occur.

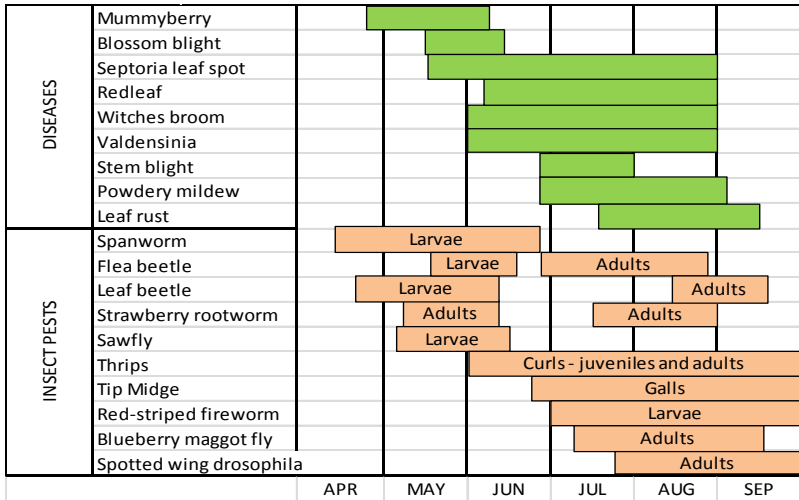

Use this table as a guide for when to begin scouting activities. Disease occurrence and insect emergence will vary slightly from year-to-year with weather conditions.

Tips for Scouting

Sweep net

Sample in a W or zig-zag pattern throughout the field with sets of 10 sweeps, each covering a 180° arc or half circle. Every set of 10 sweeps should be taken at different locations on the transect. 10-20 sets of sweeps are necessary for a good sample, large number of sweeps on larger fields.

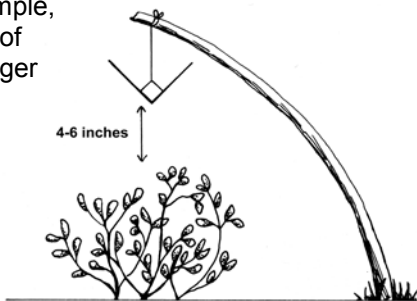

Placement of blueberry fly-sticky traps

Tips for Scouting



Yellow-baited panel trap for maggot fly.

Place traps just above (4-6 inches) plants 100-200 feet apart along wooded edges 25 feet from edge of fields, 1-3 traps per 10 acres. Place traps in field locations that have high weed or fruit density.

A **10-20 x hand lens** will help to identify insects and diseases.



Thrips Monitoring

Yellow sticky card for thrips monitoring and timing of insecticide application.



Tips for Scouting

Plant damage:

Defoliation in pruned fields

- disease or often spanworm or flea beetle

Chewed or scalloped leaves

- often spanworm, sawfly or flea beetle
- strawberry rootworm (shothole)

Leaf curls or galls

- thrips (curled leaves around entire stem)
- gall midge (terminal end of stem)

Tied leaves

- red-striped fireworm

Skeletonized leaves

- leaf beetle (brown lace-like leaves)

Stem galls

- stem gall wasps (woody growths on central stem)

Stem lesions

- disease or plant bugs (red sunken lesions on stem)

Tips for Scouting

Bare patches:

Disease, spanworm, flea beetle, strawberry rootworm, cutworms, herbicide damage, waterlogged soils

Dead or discolored stems/patches:

Disease, nutrient deficiencies, herbicide damage, winter injury, plant bugs

Tips for Scouting

Sampling for disease pressure

Use a 1'x1' frame and count the number of blighted upright stems and blossoms.



Sampling leaf tissue at tip-dieback (See leaf and soil nutrition section)



Blueberry at tip-dieback.

Tips for Scouting

- Collection bags or vials to hold samples for identification and clipboard for scouting forms and maps.
- Field maps to document locations of pest outbreaks and scouting efforts.
- Wire flags to mark areas of interest.



Field maps available at <http://maps.google.com/>

Tips for Scouting

Assessment of pollinator activity

During full bloom, stake out 1-yard square areas and count native and honeybees in that area for 1 minute at a time between the hours of 10 a.m. and 2 p.m. Stake out 8-10 of these per field.



Example of wire sample frame.

When and Where to Sample

Sample representative location, be sure to include:

- Edges (especially maggot fly and leaf beetle) and interior of fields.
- Random sites across the field.
- Early morning, mid-day (bees) and late afternoon.
- After a rain event, NOT during one.

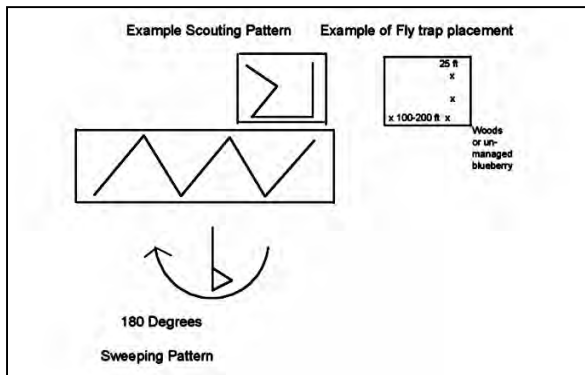

Walk in different areas of the field.

Wild Blueberry Growth Stages: Prune year





Emergence	Tip-dieback	Leaves red	Leaf drop and bud set
			
Early-mid May	Early-mid July	September - early October	October - November

Table of Contents

Wild Blueberry Growth Stages: Crop year







Green tip	Leaf expansion	Early bloom	Full bloom	Green fruit	Fruit ripening	Fruit ripe
						
Mid-late April	May	Early-mid May	Late May-early June	Mid-late June	July	Late July-August

Table of Contents



Diseases

Diseases

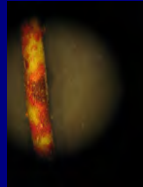
Mummyberry (*Monilinia vaccinii-corymbosi*)

Primary-stage symptoms: Two to three weeks before full bloom affected leaves wilt and infected leaves and flowers turn brown and produce a gray spore mass at the base of leaves and flowers. Early symptoms will only show the center of the leaf with reddish-brown symptoms. Disease severity will vary by clone, from only a few leaves to the entire stem affected.



Leaf (left) and flower (right) symptoms showing spore production at the base (yellow circles).

Mummyberry – *continued*



Infected fruit producing pseudosclerotia (left) and apothecia germinated from pseudosclerotia (right).

Second-stage symptoms: Cream-colored spores (conidia) produced at the base of diseased leaves or flowers are blown or carried by insects to healthy blossoms. The fungus grows in the infected berry and results in a hard, pumpkin-shaped, brownish-gray pseudosclerotium. Pseudosclerotia will germinate to produce goblet-shaped apothecia in April to May of the following year or two.

Diseases

***Botrytis* Blight** (*Botrytis cinerea*)

Botrytis causes flower blight but can also infect leaves and stems. Within a few days of infection, tissues will turn brown and die but stay attached to the plant. Dead tissues develop black “hairs” with grayish tips that are spore masses within days after infection.

Botrytis blight may be distinguished from frost damage by the presence of the fungus on blossoms and by the lack of frost damage on other plants in the immediate area. Mummy berry blighted flowers will have gray spore masses at the base of dead leaves and flowers and will lack black hairs. In contrast to flowers that have not been pollinated, dead blossoms remain attached. Scout early blooming blueberry clones and dying leaves on weeds for early signs of this disease (see pictures on the next page).

Botrytis blight - continued



Botrytis blossom blight symptoms on flowers (left) with spores still attached and with black “hairs” characteristic of the fungus (right).



Flowers with frost damage; compare symptoms with mummy berry and *Botrytis* pictures.

Diseases

Valdensinia leaf spot (*Valdensinia heterodoxa*)

Leaf spots are usually round, large brown spots with darker margins and have a spore that looks like a thorn in the middle of the lesion typically on the underside of the leaf. Infected young leaves may fall off the plant while still green. Older infected leaves stay on the plants. Heavy infections early in the season can cause complete defoliation. The fungus overwinters in leaf litter and will produce spores after a wet period during bloom and then after each rain during the summer. The fungus can be spread by leaves sticking to equipment, clothing or shoes.



Lesions on top (left) and bottom of leaf (right).

Diseases

Septoria Leaf spot (*Septoria* sp.)

Stem lesions are visible during bloom and are red with purple margins. Leaves and stems become infected during bloom in wet weather. Leaf lesions are small (pin-prick) water-soaked spots on the underside of leaves in mid-June, and the spots become necrotic and appear as small red to brown spots on the top of the leaf by July. Spots can merge together as they expand. Severe spotting can cause defoliation of some clones in dry weather in July and August.



Septoria lesions on crop stems during bloom (left), water soaked early lesions on underside of leaf (middle) and later black to red lesions (right).

Diseases

Powdery mildew (*Erysiphe* species)

In most years, powdery mildew starts to appear end of June and may continue to spread through the summer. Symptoms appear on the top of the leaves and rarely are seen on the bottom of the leaf. Diseased leaves have symptoms ranging in appearance from small red spots and rings to dark red areas to areas covered with a white dusty powder (spores). When the disease is severe, some clones may shed their leaves prematurely.

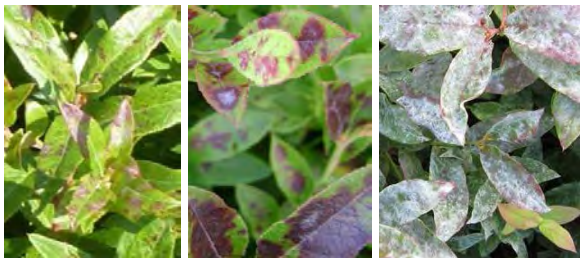

Powdery mildew symptoms ranging from small spots (left), red areas with some spores (middle) to heavy spore production (right).

Diseases

Leaf Rust (*Thekopsora vaccinii*)

Leaf rust lesions are seen mid-July or later in both prune and crop fields. Symptoms are initially small yellow to brown spots which can develop into brown spots with diffuse red margins. The key distinguishing character is the raised yellow to rust colored powdery pustules on the lower leaf surface. Leaf drop can be extensive in some clones in early September and can affect flower bud formation in prune year plants.

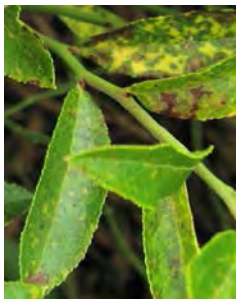

Leaf rust symptoms on top of leaf (left) and bottom of leaf with rust colored spores (right).

Diseases

Stem blight (*Phomopsis vaccinii* or *Godronia* sp.)

Symptoms typically are seen in late June and July with blighting of isolated patches of stems in prune and crop year. Dead stems usually occur in scattered patches of one to a few stems. The infected stem tissue is reddish brown and dead reddish brown leaves remain attached to the stem for some time. The infection does not appear to spread out from individual patches of infected stems.



Stem blight in prune (left) and crop year plants (right).

Diseases

Red leaf (*Exobasidium vaccinii*)

Most leaves of affected plants are blotchy with red to beet red coloration. About July, a white layer of spores develops on the underside of the leaves. Few or no fruit develop, and some twigs may be killed. In the field, diseased stems often occur by themselves in clusters coming from the same rhizome. In some cases, the disease will appear in patches that may be a foot or more across.



A patch of red leaf in a blueberry field (left) and white spores developing under leaves (right).

Diseases

Witches' broom (*Pucciniastrum*)

This disease appears as a broom-like mass of swollen stems in both prune and crop years. The infected bunches of stems are in low numbers and typically do not spread.



Blueberry stems affected by Witches' broom in first year (left) and second year of growth (right).

Insects

Insect Action Threshold Table

Apply control only if action threshold levels are reached.		
	Thresholds	
Insect Pests	Crop fields	Prune fields
Blueberry spanworm larvae	10/set of 10 sweeps	5/set of 10 sweeps
Flea beetle larvae or adults	50/set of 10 sweeps	50/set of 10 sweeps
Blueberry sawfly larvae	50/set of 10 sweeps	50/set of 10 sweeps
Strawberry rootworm adults	50/set of 10 sweeps	50/set of 10 sweeps
Leaf beetle larvae or adults	No established thresholds	
Red-striped fireworm larvae	No established thresholds	
Blueberry maggot fly	A cumulative total of 10 flies per trap	

Apply control only if action threshold levels are reached.

Apply control only if action threshold levels are reached.		
	Thresholds	
Insect Pests	Crop fields	Prune fields
Blueberry thrips		Presence of thrips on sticky trap - time to apply control OR ¼ - ½ inch and again at 1 inch sprout shoot length – time to apply control
Spotted wing drosophila	1 male fly in trap	

Add bees if observation levels are not met (or see calculation for fruitset).

Bees	Crop fields
Honeybees	2 bees / sq yd / minute
Bumblebees	0.1 bees / sq yd / minute
Native bees & honeybees	1 bee / sq yd / minute
$\% \text{ FRUITSET} = 14 + (8 \times \text{honeybees} / \text{min}) + (18 \times [\text{native} + \text{bumblebees} / \text{min}])$	



Insects

Insect Pests

Blueberry spanworm (*Itame argillacearia*)

Young caterpillar larvae are about 1/8 inch long and gray to black with a series of white bands encircling the body. Fully grown larvae are an inch long and are yellowish-orange with rows of black spots that may look like continuous black strips running the length of the body. Larvae are most active under low light conditions, early morning and evening, so this is the best time to sample. Cold wet springs can kill larvae. Also, after 2-3 years of an outbreak, virus disease and parasitic wasps collapse their populations.



Full-grown blueberry larva (left) and moth (right).

Blueberry spanworm - *continued*

Damage may be confined to isolated areas or widespread. Large numbers of spanworm larvae may completely defoliate areas in both crop and pruned fields. Early in the season, larvae damage the berry crop by eating flower buds and blossoms. Later larvae chew notches out of developing leaves. The first sign of a severe infestation in a pruned field is an area devoid of or with slower developing shoots at ground level or below the soil surface. Adults begin to emerge in late June and remain active through mid-summer. ONLY larvae can be targeted for control during the crop year. Bt works against larvae and will not harm bees. Eggs can be targeted with burning.

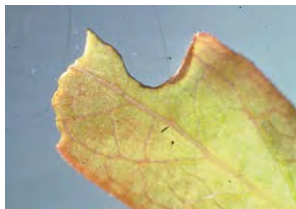

Spanworm leaf damage (left) and bare patch due to spanworm feeding (right).



Spanworm damage to a pruned field, note delayed sprout emergence.

Insect Pests

Blueberry leaf beetle (*Pyrrhalta vaccinii*)

Adults range in color from brownish-yellow to reddish-brown. The larvae are light greenish-gray and are about 1/8 inch long when fully grown. Larvae and adults feed on underside of leaves and only between leaf veins resulting in a skeletonized appearance. These skeletonized leaves turn brown and look like the leaves have been burned. Found along field edges (in spring, and again in late summer - fall). Target adults for control.



Leaf beetle damage (left) and adult (right).

Insect Pests

Blueberry sawfly (*Neopareophora litura*)

Adults are inch long, black, and generally wasp-like in appearance but do not have the narrow waist usually associated with a wasp. They have membranous wings which they hold flat over their body. The slow moving caterpillar-like larvae are usually the color of blueberry foliage, which makes them difficult to detect directly on foliage. Fully grown larvae are about 4/10 inch long. When feeding, young larvae feed in inner leaf whorl and leave black feces in whorl, full grown larvae coil their body over the edge of the leaf and chew around the edge, scalloping leaf edge. Control full grown larvae, although this can occur during bloom and Bt will not work against these larvae.



Blueberry sawfly larva (left) and adult (right).

Insect Pests

Strawberry rootworm (*Paria fragariae*)

Adults are shiny oval beetles, about 1/8 inch long. Their color varies from brown with four darker blotches on the back, to solid black. Although this insect is more commonly a pest of strawberries, when adults are abundant they will also feed on blueberry leaves. Leaves will be riddled with small holes giving the plants a ragged “shothole” appearance. Target adults, monitor in early evening when they are active. The adults tend to be found in wet areas of fields and near strawberry, raspberry or other bramble plants that serve as larval hosts.



Strawberry rootworm adults.

Insect Pests

Blueberry flea beetle (*Altica sylvia*)

Immature flea beetle is a small, black larvae about 3/8 inch long when fully grown. Adult beetle is oval shaped, shiny, copper colored, and less than an inch long. Adult flea beetles tend to jump suddenly when disturbed. Larvae are present from late May through late June often overlapping with bloom; cause scalloped leaves or complete defoliation. High densities cause bare spots in prune fields. Adults begin to emerge 2 weeks later and remain through late summer. Both larvae and adults can be targeted for control. However, adults disperse within 2 weeks after emergence. Eggs can be targeted with burning.



Flea beetle larva (left) and adult (right).

Insect Pests

Blueberry thrips (*Frankliniella vaccinii* & *Calinathrips kainos*)

Thrips are very small (1/8" long), and difficult to see. Thrips are more reliably identified by the presence of tightly rolled-together leaves and twisted around stems on blueberry plants beginning in late May and early June. Infested leaves often turn bright red and are conspicuous. By late June and July stems are often completely surrounded by curled leaves, resulting in no flower buds the following year. Thrips damaged plants can be found in crop or pruned fields, but the most economically important damage is in pruned fields. Control emerging thrips in prune fields just as shoots show green tissue (1/4" long) and again when shoots are 1 " long or control mature curls with a delayed burn.



Thrips (left) and patch of curls (right).

Insect Pests

Tip midge (*Dasineura oxycoccana*)

Tip midge larvae are very small and not visible to the naked eye. A better way to identify this insect is through the loosely woven galls that are formed at the terminal ends of blueberry leaves. These galls are usually mistaken for thrips damage, but there are a few key differences. Tip midge galls are only formed at the terminal end of leaves, they will not encompass the entire stem. Leaves with tip midge galls are green in color, whereas leaves with thrips curls generally turn a bright red. Finally, tip midge galls are a more loose curl, whereas thrips curls are tightly rolled, almost like a cigar. Usually not considered too damaging, but in some years, 50% flower bud reduction may result.



Tip midge gall

Insect Pests

Red-striped fireworm (*Aroga trialbamaculella*)

Young caterpillar larvae have a greenish body with darker heads. As they grow, reddish lines running the length of the body appear on the back and sides. Fully grown larvae are large and red, about 3/8 inch long and become very active when disturbed. They are found feeding between leaves that they have tied together with strands of silk. To identify fireworm damage, look for terminal leaves webbed together with silk in July. Target young hatching larvae prior to webbing or burn over wintering larvae in duff after crop year. Damage tends to be more of a harvest nuisance.

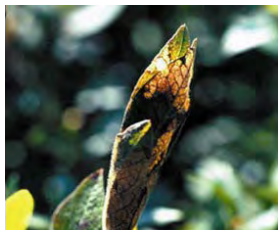

Red-striped fireworm larva (left) and webbed terminal leaves (right).

Insect Pests

Spotted wing drosophila (*Drosophila suzukii*)

Adults are pale yellow to light brown and have dark brown, unbroken horizontal stripes on the dorsal side. They have bright red eyes. The male flies can be easily distinguished by the single dark spot at the tip of each wing. The SWD males can also be distinguished by two rows of spines on their forelegs. Female SWD are slightly larger and lack the wing-spots. They can, however, be identified by their dark, heavily serrated ovipositor. SWD will lay eggs in red and blue blueberry fruit that is still maturing; therefore, monitoring should begin as green berries begin to turn pink. Traps should primarily be hung in a shady area on the field edge in a shrub or small tree at chest height. A minimum of 4 traps per field should be used (2 along field edge, 2 in field). The trap recommended for SWD monitoring is a RED plastic cup trap made from a 16-32 ounce Solo type cup and lid with 8 to 10, 1/8 to 3/16 inch diameter holes drilled along the upper rim. Traps are baited with approximately 5 ounces of a yeast-sugar-water mixture (1 TBS yeast + 4 TBS sugar

Spotted Wing Drosophila - continued

+ 12 oz water). Monitoring for larvae in fruit is with the Salt Test. This is performed by collecting 1 QT ripe berries, add to 1 gallon plastic bag and add 1/4 cup salt to 4 cups water, then crush fruit gently, wait 15 minutes for larvae to float to top. SWD in Maine appears to be a mid to late season pest. Thus early harvest (prior to August) may result in avoiding SWD infestation. A decision to spray should be based on trap captures. Upon trapping the FIRST MALE (wings with spots) the grower should consider harvesting immediately if practical, or protecting with insecticides every 3-7 days (depending on insecticide) until harvest.



Spotted wing drosophila female (left) and male (right).

Insect Pests

Blueberry maggot fly (*Rhagoletis mendax*)

The female fly is about 3/16 inch in length with a wing span of approximately 1/3 inch. The female abdomen is pointed and black with four white cross-bands. The thorax is basically black with a small, backward-pointing, white projection. The two large compound eyes are reddish. The male fly is somewhat smaller than the female. The wings of both sexes are clear and are marked with characteristic black bands (need magnifier to see well). BMF can be found throughout the field but are in highest density along field edges. Adults or the fly are the target of control. Monitoring is based upon baited sticky traps (see scouting).

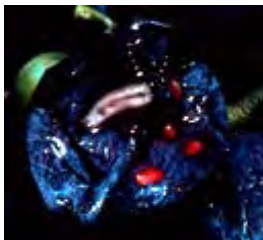
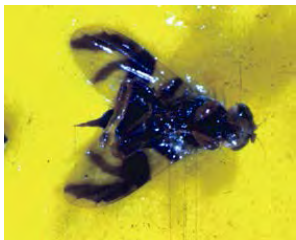

Adult maggot fly (left), and maggot in fruit (right).

Blueberry Maggot Fly - *continued*

Ten flies/trap is the threshold (see action thresholds). Spot treatments work if a grid of traps is used, and perimeter field treatments are also effective. Sanitation of winnowed fruit is also important. There are three other species of fruit flies that can end up on the traps used to monitor for blueberry maggot flies: the black cherry fruit fly (BCFF), the cherry fruit fly (CFF), and the walnut husk fly (NWHF). These flies are distinguished by their wing patterns but they do NOT attack blueberries even though they are trapped in fields. The BMF has a continuous dark wing pattern. The BCFF has a small, oval, clear spot in the wing and the CFF's dark wing pattern is not continuous. The NWHF's wing pattern closely resembles that of the blueberry maggot fly. However, the walnut husk fly's wing pattern is not continuous, and the outer edge of the wing is black.

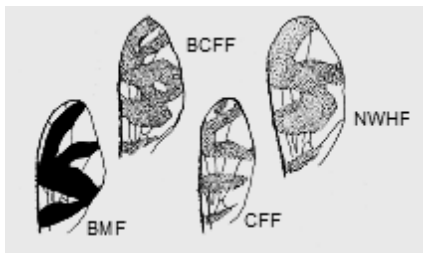

Insect Pests

Grasshoppers

Grasshoppers vary in color from greenish-yellow to gray to brown to brownish-black. The hind legs are large and adapted for jumping. All vary in size up to 1 1/4 inches long when grown. Immature grasshoppers are smaller and closely resemble adults but do not have wings. Both young grasshoppers and adults feed by biting and chewing on berries. Feeding damage is often detected later as a calloused scar on the fruit. Target nymphs (immature) and adults. Mostly a problem in grassy fields since grasshoppers feed on grasses first and shift to berries in dry conditions.



Grasshopper (left) and feeding damage (right).

Insect Pests

Plant bugs

Plant bugs feed on the stems and leaves of many plants, causing them to curl or spotting the leaves, reducing growth. They are considered a minor pest in blueberries. Generally, not a source of economically important damage.



Plant bug.



Insect Natural Enemies

Insect Natural Enemies

Natural enemies are beneficial organisms that can provide a degree of pest control by eating or parasitizing pest insects. Promoting natural enemies may even provide suppression of minor insect pests. Maintaining a diversity of habitats, especially areas rich in flowering herbaceous plants and shrubs surrounding blueberry fields can promote natural enemies. This is because alternate insect prey often resides upon these plants. When spraying insecticides, care should be taken to choose insecticides with low predator toxicity, and spray only when necessary (see *Wild Blueberry Fact Sheet*, *Wild Blueberry Pesticide Chart-Insecticides*). The major insect natural enemies in Maine blueberry fields are wolf spiders, daddy longlegs, ground beetles, ants, and parasitic wasps. Our studies have shown that parasitic wasps regulate blueberry fly populations and blueberry spanworm populations, lowering their potential for extreme infestation levels or reducing the length of the outbreak period. Also, we have shown that spiders reduce spanworm and grasshopper populations, and that ants readily prey upon blueberry flea beetles and blueberry spanworm, reducing their populations up to 50 yards from an ant mound nest.

Natural enemies

Wolf Spiders

Wolf Spiders (Lycosidae) are generalist predators present all spring and summer in all parts of blueberry fields. These ground dwelling, non-web spinning spiders ambush insect pests that inhabit the ground surface. Therefore, they tend to concentrate on insect pest larvae just as they move into the soil to pupate such as blueberry spanworm, blueberry flea beetle, red-striped fireworm, and blueberry fly.



One of the most common wolf spiders in the genus *Hogna*.

Natural enemies

Phalangids

Phalangids (*Phalangium opilio*) or **Daddy longlegs** is the most abundant species in blueberry fields and seem to favor agricultural habitats. They become more abundant towards the end of the growing season and are known to eat a wide variety of pest and non-pest arthropods, especially soft bodied insects such as caterpillars and beetle larvae. Daddy longlegs tend to colonize blueberry fields from field edges and build up to high densities in mid to late summer.



Daddy longlegs



Example of common ant

Natural enemies

Ants

Ants (Formicidae) are recognized by a constricted waist, elbow antennae, and wingless (except for reproductive stages). Ants are present in blueberry fields from mid-May through the growing season. There are many species (61) in Maine. Low insecticide input (i.e. organic) tends to result in higher numbers of ant colonies. One of the most common ants in blueberry fields is the Allegheny mound ant. It is a voracious predator.



Allegheny ant mound.

Natural enemies

Ground Beetles and Parasitic Wasps

Ground beetles: many species, some are insect predators, some eat weed seeds. These beetles are found in all parts of the blueberry field from May to August. Dark, black-brown in color, rarely fly, run fast.



Parasitic wasps: two species specific to blueberry spanworm, at least one species specific to blueberry maggot fly. This species of parasitic wasp can parasitize up to 38% of BMF pupae. Most years, parasitism rates are closer to 3-10%. However, even at these percentages they do not regulate populations.



Parasitic wasp specific to blueberry maggot fly (*Diachasma alloeum*).

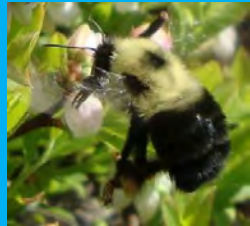
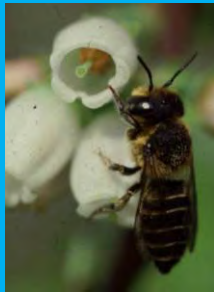

Bees

Bees – Overview

Pollinator Conservation

Diversity: There are more than 100 bee species associated with wild blueberry in Maine. Most are native to Maine, have co-evolved with wild blueberry, and are particularly efficient pollinators of the crop. Native bees that visit flowers of the wild blueberry reduce the need for commercial pollination services, and this makes it prudent to support native bee populations through conservation practices.

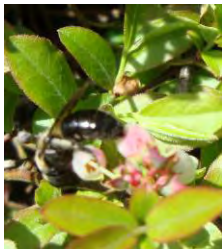

Andrena vicina, a native solitary bee, on wild blueberry.

Most native bees associated with wild blueberries belong to four families: *Apidae*, *Andrenidae*, *Halictidae* and *Megachilidae*.

Nontechnical information about each of these groups is provided in this booklet.



Sweat bee (*Agapostemon virescens*) on valerian flowers.

Bee species can differ in their susceptibility to disease, parasites and adverse weather. Encourage a diversity of bee species in your fields as a way to increase likelihood that native bees can contribute to crop pollination despite an impact such as a cold, wet spring.

Pollinator Conservation: While it is valuable to know which bee species are present, a realistic approach to supporting native bee populations is by promoting bee habitat. This includes alternate forage (flowering plants the bees visit when blueberry is not in bloom) and nest sites such as bare earth, rock walls, standing snags, bunch grasses, plants with hollow or pithy stems, and artificial nests.

Pollinator Conservation - *continued*

Habitats for forage and nesting are at field edges, ponds, access roads, parking areas and near buildings. A water source may be helpful especially for honey bees; float a piece of wood in the water as a landing platform. Maintain forage habitats by mowing infrequently. Protect bee habitat from pesticide drift.



Plasterer bee (*Colletus compactus compactus*)
at entrance to her ground nest.

Pollinator Conservation - *continued*

Pollinator strips and bee gardens can be installed to support bees, including native bees. See a list of suggested plants to include in Cooperative Extension Bulletin 7153, *Understanding Native Bees, the Great Pollinators: Enhancing Their Habitat in Maine*. Bee forage plants are marked in this booklet on pp. 70-83 with a bee symbol. 

Many plants considered to be weeds in the field can offer valuable food resources for pollinators at field edges and in bee plantings and conservation areas. In addition to those in the list, bees visit apple, dandelion, pin cherry, wild raisin, serviceberry, mustards, northern fly honeysuckle, and bluets.



A pollinator strip made up of wild flower mix.

Bees

Life Cycle of Solitary Bees

Except bumble bees, most native bees are solitary. The life cycle consists of four stages. Females each prepare a nest and provision their brood. An individual bee may be active for 3 weeks to several months.

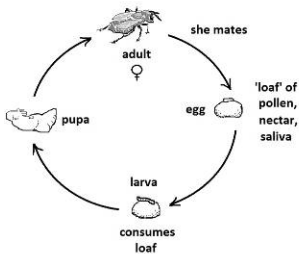

Be a BEE OBSERVER: Bees that we see on flowers tend to be mostly the females. They are busy gathering nectar and pollen to provision their offspring. They rarely sting and are not a hazard to most people. They may tolerate close observation and photography, if you move slowly and avoid casting a shadow on flowers they are visiting.

Bees

Bees and Pesticides

Bees are highly vulnerable to pesticide sprays. You can reduce harm to pollinators:

- Ask first, "Is it necessary to spray?" I.D. the pest and scout to determine if it is at threshold levels. Spray only when pest levels are at threshold (see pp. 27-28).
- If threshold is reached, select the least toxic treatment and use the minimal amount necessary. See Wild Blueberry Fact Sheet 630, *Wild Bee Conservation for Wild Blueberry Fields*, for a table ranking toxicity to bees of commonly used pesticides.
- During application, prevent drift onto pollinator habitat by remaining alert to wind direction and other factors that impact drift (pp. 97-100).

Bees – Commercial Options

Honey, Bumble & Leaf-cutting Bees

Commercial options

See the table on page 28 to determine whether it is advisable to add bees to your fields.

Honey bees: The honey bee worker is about 3/4 inch long, with color ranging from light brown to almost black. Colors vary by race and/or subspecies in the U.S. (e.g., Italians, Caucasians, Carniolans, and Africans). The eyes are large and usually shiny black, while the thorax (where the six legs and two pairs of wings are attached) is covered with a dense mat of brown hairs. The abdomen is long and often has alternating light and dark bands or rings. Because of problems with varroa mite, wild honey bees are unlikely to persist in Maine. Honey bees are the most common commercial pollinator because it is possible to stock fields with vast numbers of individuals (see Wild Blueberry Fact Sheet 629, *Honey Bees and Blueberry Pollination*).

Commercial options - *continued*

Honeybees have a difficult time obtaining pollen from blueberry flowers and so have low efficiency in pollinating flowers in subsequent visits.

However, the numbers of individual bees brought to the crop during bloom usually compensate for this lack. Valuable honey, wax, and pollen collected in the hive are not available from any other type of bee in North America. Colony Collapse Disorder, apparently caused by multiple stressors, has made ongoing pollination services by honey bee less certain since the mid-2000s.



Honey bee worker on buckwheat flowers.

Commercial options - continued

Bumble bees: Bumble bees are black and yellow or black and orange, with a hairy thorax and abdomen. The Impatient Bumble bee, *Bombus impatiens*, is managed for commercial pollination services (Wild Blueberry Fact Sheet 302, Commercial Bumble Bee Management for Wild Blueberry Pollination).

Most of the smaller black-and-pale-yellow workers seen in blueberry fields

belong to the commercial species (Wild Blueberry Fact Sheet 630, *Wild Bee Conservation for Wild Blueberry Fields*). Bumble bees are the most efficient pollinators of wild blueberry, on a per bee basis. They visit flowers even during cool, drizzly weather. They buzz pollinate, or vibrate their flight muscles rapidly while collecting pollen, to shake sticky pollen out of the tube-like anthers of wild blueberry flowers.



Impatient bumble bee worker on wild blueberry.

Commercial options - *continued*

By comparison, honey bees are not able to access the pollen as easily because they do not buzz pollinate.

Alfalfa leafcutting bees: These introduced bees are good pollinators of wild blueberry. They are particularly suited for pollinating large, weed-free fields. They do not thrive during a cold spring (Wild Blueberry Fact Sheet 300, *How to Manage Alfalfa Leafcutting Bees for Wild Blueberry Production*).



Alfalfa leafcutting bee on wild blueberry flower.

Bees - Native Native Tunnel-Nesting Bees

Maine has more than 30 species of **Leafcutters or Mason Bees** (family Megachilidae). Their nests are in the soft pith of some shrubs (elderberry, raspberry) or in old borer holes in trees. Some can cut circular pieces from leaves using their large mandibles, while mason bees collect mud to seal their nests. In the tunnel the female bee lays her egg upon a tiny loaf of pollen, nectar, and saliva, then seals the chamber off. Fast-moving dark blue bees in the genus *Osmia* can be challenging to photograph on flowers.



Native leafcutter bee, *Osmia* sp.

Native, tunnel-nesting bees – *continued*



disc of fresh leaf cut by bee with her sharp mandibles

If you see round holes in leaves around the farm, this could be evidence that leafcutter bees are present. The bee flies to its nest while holding the piece of leaf.

Artificial nest blocks can be set at field edges in an effort to increase the populations of leafcutter bees (see Wild Blueberry Fact Sheet 301, *Field Conservation Management of Native Leafcutting and Mason Osmia Bees*). Use untreated wood, and do not paint or polyurethane the blocks.

Inside a nest block that you might put up around your fields; the nest could resemble this diagram.

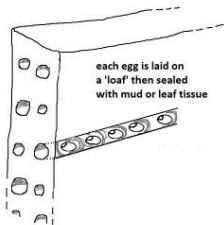

Bees - Native

Native, Soil Nesting Bees

In general, ground nesting bees are solitary. From the side, the nest could be arranged as in this diagram.

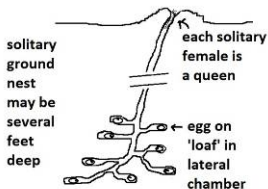

The new bee emerges from the soil, mates, and then the female excavates a nest and lays her eggs. The bee may guard the entrance hole while she waits for sun.

Sand bees, digger bees, miner bees: Bees in the family Andrenidae nest in soil tunnels with side-chambers in which they lay their eggs. Maine has at least 45 species of *Andrena*, including some excellent pollinators on wild blueberry. Many are active in spring. A few might have interconnecting nests belowground.

Native, soil-nesting bees - *continued*



Andrenid nest hole with loose excavated soil, called tumuli.



An aggregation of nest holes. Perhaps several bees use the same hole, or there are inter-connections between nest tunnels.

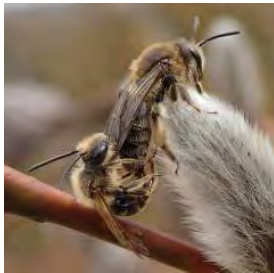

Andrenids mating at willow, Blueberry Hill Farm, Jonesboro, ME

Native, soil-nesting bees – *continued*

Sweat Bees: Bees in the family Halictidae are native and solitary. These, too, usually nest in burrows in the soil, sometimes in rotting wood (see Wild Blueberry Fact Sheet 630, *Wild Bee Conservation for Wild Blueberry Fields*, for conservation tips). Some are metallic green and easy to recognize, others are tiny, black, and not much noticed. Their effectiveness in wild blueberry pollination is not well-established but their diversity and abundance indicate a healthy ecosystem.



Metallic green sweat bee (*Augochlora* sp.)

Bees - Native Native Bumble Bees

Seventeen species of native bumble bees are in Maine (Family Apidae). Native populations of impatient bumble bee may be in southern Maine. One of the most common is the easily recognized orange-banded bumble bee (below). A large bumble bee noticed in early spring or visiting wild blueberry flowers is a mated queen that overwintered perhaps at the base of a large tree in the woodlot.



Orange-banded bumble bee (*Bombus ternarius*).

Bumble bees - *continued*

She will typically occupy an abandoned rodent nest among bunch grasses, at stone walls, or in weedy edges. She is the founder of the colony. Her daughters pollinate many kinds of plants long after wild blueberry fruits have started to form, and members of the colony are active until hard frost. Several of the daughters will mate in autumn and become queens for the next year, but the original queen dies before winter.

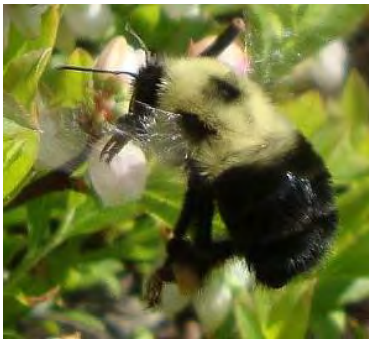

Half-black bumble bee, *Bombus vagans*, a native species.



Herbaceous Perennials



Woody Perennials



Annual Grasses



Perennial Grasses



Sedges and Rushes

Weeds

Weeds

Annual versus Perennial Weeds

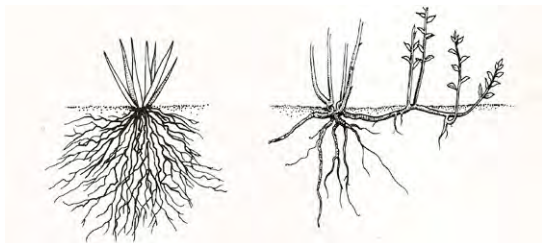

Annuals germinate, set seed, and die within a single year. Roots are usually fine and net-like.

Perennials may live for many years. Roots are generally larger than those of annuals, and may help the plant to spread.

Weeds

Grasses, sedges, and rushes

Structural characteristics of grasses, sedges, and rushes.

Grasses



Culm in cross section-hollow between nodes



Leaf blade, sheath, and culm

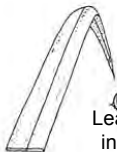

Cross section of flattened blade



Leaves in 2's
Single seeded fruit (grain)



Seedling seen from above

Grasses, sedges, and rushes – *continued*

Sedges



Culm solid, in cross section-triangular in many sedges



V-shaped leaf near base or around culm



Leaves in 3's



Single seeded fruit



Seedling seen from above

Rushes



Culm in cross section-round usually with a solid pith



Leaf reduced to a basal sheath, no swollen nodes



Fruit a 3-chambered capsule, many seeds per capsule



Seedling seen from above

Weeds - Herbaceous Perennials







Goldenrod (<i>Solidago spp.</i>)	Aster (many genera)	Black-Eyed Susan (<i>Rudbeckia hirta</i>)
		
<p>Many species, flowering from July-October. </p>	<p>Many asters are found in Maine. </p>	<p>Flowers May to September. </p>

Table of Contents

Weeds

Weeds - Herbaceous Perennials







Bunchberry (<i>Cornus canadensis</i>)	Common Milkweed (<i>Asclepias syriaca</i>)	Fireweed (<i>Chamerion angustifolium</i>)
		
Flowers mid-May to June with blueberry. 	Reproduces by seed and rhizomes. 	Germination stimulated by soil disturbance. 

Table of Contents

Weeds

Weeds - Herbaceous Perennials





Common Evening Primrose (<i>Oenothera biennis</i>)	Spreading Dogbane (<i>Apocynum androsaemifolium</i>)	Blackberry, Raspberry, Dewberry (<i>Rubus spp.</i>)
 A photograph of a Common Evening Primrose plant with several bright yellow flowers on a tall, green stem. The background shows a grassy field and a body of water under a blue sky.	 A photograph of a Spreading Dogbane plant with numerous small, light purple flowers and green, rounded leaves. The plant is growing in a dense, green thicket.	 A close-up photograph of the leaves of a Rubus species, showing their characteristic three-lobed shape and serrated edges. The leaves are bright green and have a prominent vein pattern.
Flowers in June-July. 	Flowers in June-July. 	Vine/canes, flowers April-May. 

Table of Contents

Weeds

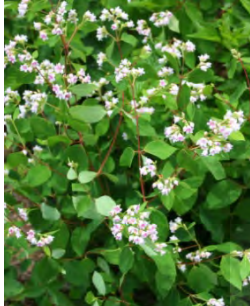
Weeds - Herbaceous Perennials





Bracken Fern (<i>Pteridium aquilinum</i>)	Interrupted Fern (<i>Osmunda claytoniana</i>)	Purple Vetch (<i>Vicia cracca</i>)
		
Reproduces by spores and creeping rhizomes.	Reproduces by spores and creeping rootstocks.	Trailing, flowers in July-August. 

Table of Contents

Weeds

Weeds - Herbaceous Perennials







Wild Strawberry (<i>Fragaria virginiana</i>)	Common Cinquefoil (<i>Potentilla simplex</i>)	Shrubby Fivefingers (<i>Sibbaldiopsis tridentata</i>)
		
Ground cover, flowers April-June. 	Vine, flowers May-July. 	Trailing, flowers June-August. 

Table of Contents

Weeds

Weeds - Herbaceous Perennials





Lambsquarters (<i>Chenopodium album</i>)	Burnweed (<i>Erechtites hieracifolia</i>)	Hawkweed (<i>Hieracium spp.</i>)
 A photograph of a Lambsquarters plant (Chenopodium album) showing a tall, upright stem with small, green, developing flower clusters at the top.	 A photograph of a Burnweed plant (Erechtites hieracifolia) showing a green stem with several large, deeply lobed leaves and a cluster of small, yellow flowers at the top.	 A close-up photograph of several bright yellow Hawkweed flowers (Hieracium spp.) with multiple petals, and one orange flower bud.
<p>Prefers bare soil; reproduces by seed.</p>	<p>Dandelion-like flower, moved by equipment.</p>	<p>Several yellow and one orange species. </p>

Table of Contents

Weeds

Weeds - Herbaceous Perennials

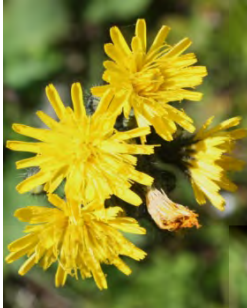





Canada Mayflower (<i>Maianthemum canadense</i>)	Cow-wheat (<i>Melampyrum lineare</i>)	Violet (<i>Viola spp.</i>)
		
Flowers mid-May to June with blueberry. 	Semi-parasitic on blueberry. 	Several species occur with blueberry. 

Table of Contents

Weeds

Weeds - Herbaceous Perennials







Blue Toadflax <i>(Nuttallanthus canadensis)</i>	St. Johnswort (<i>Hypericum perforatum</i>)	Sheep Sorrel <i>(Rumex acetosella)</i>
		
Flowers June–July. 	Yellow flowers July-August. 	Red flowers May–September. 

Table of Contents

Weeds

Weeds - Herbaceous Perennials





Clover (<i>Trifolium spp.</i>)	Golden Clover (<i>Trifolium aureum</i>)	Hop Clover (<i>Trifolium arvense</i>)
		
Red/purple and white species, fix nitrogen. 	Yellow flowers June-July.	Flowers August - September. 

Table of Contents

Weeds

Weeds - Woody Perennials





Birch (<i>Betula</i> spp.)	Speckled Alder (<i>Alnus incana</i>)	Willow (<i>Salix</i> spp.)
		
<p>Slender tree with smooth white or grayish bark.</p>	<p>Small shrub 5' to 20' tall or a tree up to 40'.</p>	<p>Shrubs or trees with catkins in early spring</p> 

Table of Contents

Weeds

Weeds - Woody Perennials





Red Maple (<i>Acer rubrum</i>)	Aspen/Poplar (<i>Populus</i> spp.)	Northern Red Oak (<i>Quercus rubra</i>)
 A photograph showing several bright green, palmately lobed leaves of a Red Maple (Acer rubrum) growing from a dark, mulched ground.	 A photograph of a branch with several green, ovate leaves of an Aspen or Poplar (Populus spp.). The leaves have a slightly wavy margin and are attached to a reddish-brown stem.	 A photograph of a cluster of green, lobed leaves of a Northern Red Oak (Quercus rubra) growing from a mossy forest floor.
<p>Multi-stemmed bush in the open.</p> 	<p>Tree, leaves shake in the slightest breeze.</p>	<p>Maine's most common oak.</p>

Table of Contents

Weeds

Weeds - Woody Perennials

81





Sheep Laurel, Lambkill (<i>Kalmia angustifolia</i>)	Meadowsweet (<i>Spiraea alba</i>)	Sweetfern (<i>Comptonia peregrina</i>)
 A photograph of a Sheep Laurel (Kalmia angustifolia) shrub. The plant has dense, bright green, lance-shaped leaves and clusters of small, vibrant pink flowers.	 A photograph of a Meadowsweet (Spiraea alba) shrub. It features a central, upright stem with clusters of small, white flowers and green, lance-shaped leaves.	 A photograph of a Sweetfern (Comptonia peregrina) shrub. The plant has finely divided, fern-like green leaves and clusters of small, brown, cone-shaped flower heads.
<p>Shrub, flowers from June-July. </p>	<p>Erect, woody, shrub 2'-6' tall. </p>	<p>Flowers April-May. Woody shrub up to 3' tall.</p>

Table of Contents

Weeds

Weeds - Woody Perennials





Rose (<i>Rosa spp.</i>)	Chokecherry (<i>Prunus virginiana</i>)	Pine (<i>Pinus spp.</i>)
		
<p>Thorny shrub up to 6' tall. Flowers May-July.</p> 	<p>Flowers in May. Shrub or small tree 4'-20' tall.</p> 	<p>Evergreens with 2 or 5 needles per bundle.</p>

Table of Contents

Weeds

Weeds - Woody Perennials









Chokeberry (<i>Aronia melanocarpa</i>)	Black Huckleberry (<i>Gaylussacia baccata</i>)	Rhodora (<i>Rhododendron canadense</i>)
		
<p>Flowers May-July with blueberry. </p>	<p>Flowers July-August. Slightly taller than blueberry. </p>	<p>Shrub 1'-3' tall. Flowers appear before leaves in early spring. </p>



Table of Contents

Weeds



Weeds - Annual Grasses

Fall Panicum (<i>Panicum dichotomiflorum</i>)	Witchgrass (<i>Panicum capillare</i>)	Colonial Bentgrass (<i>Agrostis capillaris</i>)
		
Summer annual with large round, smooth sheaths; often bent at nodes.	A densely hairy erect summer annual grass up to 32" height.	Grass fine leaf, very dense and light colored, 1 to 2" in height.



Weeds - Perennial Grasses

Sweet Vernalgrass (<i>Anthoxanthum odoratum</i>)	Canada Bluegrass (<i>Poa compressa</i>)	Kentucky Bluegrass (<i>Poa pratensis</i>)
		
Fragrant when dry.	Stem flattened below inflorescence, which can be 1 or 2-sided.	Similar to <i>P. compressa</i> but 2-sided and stem not flattened.



Weeds - Perennial Grasses

Quack-grass (<i>Elymus repens</i>)	Fineleaf Sheep Fescue (<i>Festuca filiformis</i>)	Wild Oat-grass (<i>Danthonia spicata</i>)
		
Reproduces by rootstock and seed. Flowers from July-September.	Reproduces by seed. Flowers from August-October.	Reproduces by seed. Flowers from July-September.

Weeds - Sedges and Rushes

Black Sedge (<i>Carex nigra</i>)	Pointed Broom Sedge (<i>Carex scoparia</i>)	Bulrush/Woolgrass (<i>Scirpus</i> spp.)
		
Perennial sedge. Flowers prior to blueberry.	Perennial sedge. Reproduces by rootstock & seed. Flowers July-September.	Perennial sedges. Several very similar species.

Weeds - Sedges and Rushes

Common Rush (<i>Juncus effusus</i>)	Wire-grass/Slender Rush (<i>Juncus tenuis</i>)	Common Woodrush (<i>Luzula multiflora</i>)
		
<p>Perennial rush. Reproduces by seed. Flowers July-September.</p>	<p>Perennial rush. Reproduces by seed. Flowers April-May.</p>	<p>Perennial rush. Flowers April-July.</p>

Nutrients

Nutrient Deficiency

Sampling plant tissue for nutrient deficiency

Cut **3** stems from **30** clones throughout the field for one sample

- Do not include soil particles
- Do not mix in other vegetation
- Pesticide and dust residue must be rinsed off
- Store samples in a clean, dry area

Send samples to:

Analytical Lab, Room 407
The University of Maine
5722 Deering Hall
Orono, ME 04469-5722

Nutrients

Soil pH

Soil samples for pH level only

- Each sample box should contain a composite of at least 15 samples scattered over a well-defined area.
- Take each composite sample from an area which is uniform with respect to texture, slope, drainage, erosion, color, or past soil management.
- Use a sampling tube, auger or spade. Take each sampling to a depth of 3-4 inches.
- Place the 15 samples of soil in a clean pail and mix thoroughly.
- Fill the sample box with the mixed soil for testing.



To obtain a sample box call 207.581.3591 or contact your county Extension office.



Herbicide Injury

Herbicide injury Velpar

Too much Velpar causes blueberry plants to lose their leaves, starting at the bottom.



Herbicide injury Roundup

Plants necrotic and then grow back stunted.



Herbicide injury Surfactant

Plants defoliated in spots where surfactant or Crop Oil Concentrate (COC) is too high.



Herbicide injury Callisto

Callisto applied when temperatures are above 80°F can cause yellowing and browning of leaves.





Abiotic Injury

Abiotic Drought injury

Plants dried out, usually in spots where soil is shallow.



Abiotic Winter-kill injury

Tips of plants dead at uniform height. Injury may be uniform across field or confined to areas that did not have good snow cover.



Factors Affecting Pesticide Drift

Droplet size

Small droplets are more likely to move off target and so should be avoided. Small droplets move faster and give better coverage but can drift more and evaporate quickly.

Spray pressure

Lower pressure creates larger droplets and higher pressure creates smaller droplets.

Spray volume

Given the same pressure, nozzles with higher output produce larger droplets.

Wind

Make applications when winds are light to moderate with wind direction blowing away from sensitive areas.

Application speed

Faster speed of application increases shearing effect and produces more small droplets.

Spray angle

Nozzles with wide spray angles (110° or more) create smaller droplets than nozzles with narrower spray angles (80° or less).

Evaporation

On warm, dry days spray droplets evaporate more quickly and are more likely to drift. It is best to spray when RH is above 70%. RH below 50% may increase the chance of drift.

Temperature inversions

Occurs when cool air is trapped near the surface by warm air, droplets remain suspended for long periods of time and are easily blown off target by the wind. Happens when applications are made early in the AM when air is still cool.

Adjuvants

Can increase droplet size and reduce drift but also may decrease the effectiveness if small drops are needed for coverage.

Low drift nozzles

Extended pressure nozzles maintain spray pattern at lower pressure and have less drift.

Estimating Wind Speed			
DESCRIPTION	OBSERVED EFFECTS	NOTES	APPROXIMATE WIND SPEED
Calm	Smoke rises vertically	Avoid fine sprays on warm sunny days	Less than 1 mph
Light Air	Smoke drift indicates wind direction; weather vanes do not move	Avoid fine sprays on warm sunny days	1 to 3 mph
Light Breeze	Leaves rustle; wind felt on face; weather vanes begin to move	Ideal spraying	3 to 7 mph
Gentle Breeze	Leaves and twigs in constant motion	Good spraying	7 to 11 mph

Estimating Wind Speed			
DESCRIPTION	OBSERVED EFFECTS	NOTES	APPROXIMATE WIND SPEED
Moderate	Small branches moved, raises dust, leaves, and loose paper	Avoid pesticides with finer sprays	12 to 15 mph
Fresh Breeze	Small trees sway	DO NOT SPRAY – Drift regulations prohibit spraying when wind speed is over 15 mph	
Strong Breeze	Large branches sway	Off target movement very likely	
Moderate Gale	Whole trees in motion		

This publication was funded by USDA/NSFA
SCRI Grant No. 2009-51181-05845, *Systems
approach to improving sustainability of wild
blueberry production.*

The University of Maine does not discriminate on the grounds of race, color, religion, sex, sexual orientation, including transgender status and gender expression, national origin, citizenship status, age, disability, genetic information or veteran status in employment, education, and all other programs and activities. The following person has been designated to handle inquiries regarding non-discrimination policies:
Director, Office of Equal Opportunity, 101 North Stevens
Hall, 207.581.1226.