

Installation Instructions

Original Instructions



Allen-Bradley

by ROCKWELL AUTOMATION

POINT I/O RS-232 and RS-485 ASCII Modules

Catalog Numbers 1734-232ASC, 1734-485ASC, 1734-485ASCK

Topic	Page
Summary of Changes	1
Before You Begin	4
Install the Mounting Base	4
Install the I/O Module	5
Install the Removable Terminal Block	5
Remove a Mounting Base	6
Wire the Module	7
Communicate with Your Module	8
Interpret Status Indicators	8
Specifications	9
Additional Resources	11

Summary of Changes

This publication contains the following new or updated information. This list includes substantive updates only and is not intended to reflect all changes.

Topic	Page
Updated Certifications	11
Added Additional Resources	11

Rockwell Automation recognizes that some of the terms that are currently used in our industry and in this publication are not in alignment with the movement toward inclusive language in technology. We are proactively collaborating with industry peers to find alternatives to such terms and making changes to our products and content. Please excuse the use of such terms in our content while we implement these changes.



ATTENTION: Read this document and the documents listed in the Additional Resources section about installation, configuration and operation of this equipment before you install, configure, operate or maintain this product. Users are required to familiarize themselves with installation and wiring instructions in addition to requirements of all applicable codes, laws, and standards.

Activities including installation, adjustments, putting into service, use, assembly, disassembly, and maintenance are required to be carried out by suitably trained personnel in accordance with applicable code of practice. If this equipment is used in a manner not specified by the manufacturer, the protection provided by the equipment may be impaired.

注意：在安装、配置、操作和维护本产品前，请阅读本文档以及“其他资源”部分列出的有关设备安装、配置和操作的相应文档。除了所有适用规范、法律和标准的相关要求之外，用户还必须熟悉安装和接线说明。

安装、调整、搬运、使用、组装、拆卸和维护等各项操作必须由经过适当训练的专业人员按照适用的操作规范实施。

如果未按照制造商指定的方式使用该设备，则可能会损害设备提供的保护。

ATENCIÓN: Antes de instalar, configurar, poner en funcionamiento o realizar el mantenimiento de este producto, lea este documento y los documentos listados en la sección Recursos adicionales acerca de la instalación, configuración y operación de este equipo. Los usuarios deben familiarizarse con las instrucciones de instalación y cableado y con los requisitos de todos los códigos, leyes y estándares vigentes. El personal debidamente capacitado debe realizar las actividades relacionadas a la instalación, ajustes, puesta en servicio, uso, ensamblaje, desensamblaje y mantenimiento de conformidad con el código de práctica aplicable. Si este equipo se usa de una manera no especificada por el fabricante, la protección provista por el equipo puede resultar afectada.

ATENÇÃO: Leia este e os demais documentos sobre instalação, configuração e operação do equipamento que estão na seção Recursos adicionais antes de instalar, configurar, operar ou manter este produto. Os usuários devem se familiarizar com as instruções de instalação e fiação além das especificações para todos os códigos, leis e normas aplicáveis.

É necessário que as atividades, incluindo instalação, ajustes, colocação em serviço, utilização, montagem, desmontagem e manutenção sejam realizadas por pessoal qualificado e especializado, de acordo com o código de prática aplicável.

Caso este equipamento seja utilizado de maneira não estabelecida pelo fabricante, a proteção fornecida pelo equipamento pode ficar prejudicada.

ВНИМАНИЕ: Перед тем как устанавливать, настраивать, эксплуатировать или обслуживать данное оборудование, прочитайте этот документ и документы, перечисленные в разделе «Дополнительные ресурсы». В этих документах изложены сведения об установке, настройке и эксплуатации данного оборудования. Пользователи обязаны ознакомиться с инструкциями по установке и прокладке соединений, а также с требованиями всех применимых норм, законов и стандартов.

Все действия, включая установку, наладку, ввод в эксплуатацию, использование, сборку, разборку и техническое обслуживание, должны выполняться обученным персоналом в соответствии с применимыми нормами и правилами.

Если оборудование используется не предусмотренным производителем образом, защита оборудования может быть нарушена.

注意：本製品を設置、構成、稼働または保守する前に、本書および本機器の設置、設定、操作についての参考資料の該当箇所に記載されている文書に目を通してください。ユーザは、すべての該当する条例、法律、規格の要件に加えて、設置および配線の手順に習熟している必要があります。

設置調整、運転の開始、使用、組立て、解体、保守を含む諸作業は、該当する実施規則に従って訓練を受けた適切な作業員が実行する必要があります。

本機器が製造メーカーにより指定されていない方法で使用されている場合、機器により提供されている保護が損なわれる恐れがあります。

ACHTUNG: Lesen Sie dieses Dokument und die im Abschnitt „Weitere Informationen“ aufgeführten Dokumente, die Informationen zur Installation, Konfiguration und Bedienung dieses Produkts enthalten, bevor Sie dieses Produkt installieren, konfigurieren, bedienen oder warten. Anwender müssen sich neben den Bestimmungen aller anwendbaren Vorschriften, Gesetze und Normen zusätzlich mit den Installations- und Verdrahtungsanweisungen vertraut machen.

Arbeiten im Rahmen der Installation, Anpassung, Inbetriebnahme, Verwendung, Montage, Demontage oder Instandhaltung dürfen nur durch ausreichend geschulte Mitarbeiter und in Übereinstimmung mit den anwendbaren Ausführungsvorschriften vorgenommen werden.

Wenn das Gerät in einer Weise verwendet wird, die vom Hersteller nicht vorgesehen ist, kann die Schutzfunktion beeinträchtigt sein.

ATTENTION : Lisez ce document et les documents listés dans la section Ressources complémentaires relatifs à l'installation, la configuration et le fonctionnement de cet équipement avant d'installer, configurer, utiliser ou entretenir ce produit. Les utilisateurs doivent se familiariser avec les instructions d'installation et de câblage en plus des exigences relatives aux codes, lois et normes en vigueur.

Les activités relatives à l'installation, le réglage, la mise en service, l'utilisation, l'assemblage, le démontage et l'entretien doivent être réalisées par des personnes formées selon le code de pratique en vigueur.

Si cet équipement est utilisé d'une façon qui n'a pas été définie par le fabricant, la protection fournie par l'équipement peut être compromise.

주의：본 제품 설치, 설정, 작동 또는 유지 보수하기 전에 본 문서를 포함하여 설치, 설정 및 작동에 관한 참고 자료 섹션의 문서들을 반드시 읽고 숙지하십시오. 사용자는 모든 관련 규정, 법규 및 표준에서 요구하는 사항에 대해 반드시 설치 및 배선 지침을 숙지해야 합니다.

설치, 조정, 가동, 사용, 조립, 분해, 유지보수 등 모든 작업은 관련 규정에 따라 적절한 교육을 받은 사용자들 통해서만 수행해야 합니다.

본 장비를 제조사가 명시하지 않은 방법으로 사용하면 장비의 보호 기능이 손상될 수 있습니다.

ATTENZIONE Prima di installare, configurare ed utilizzare il prodotto, o effettuare interventi di manutenzione su di esso, leggere il presente documento ed i documenti elencati nella sezione "Altre risorse", riguardanti l'installazione, la configurazione ed il funzionamento dell'apparecchiatura. Gli utenti devono leggere e comprendere le istruzioni di installazione e cablaggio, oltre ai requisiti previsti dalle leggi, codici e standard applicabili.

Le attività come installazione, regolazioni, utilizzo, assemblaggio, disassemblaggio e manutenzione devono essere svolte da personale adeguatamente addestrato, nel rispetto delle procedure previste.

Qualora l'apparecchio venga utilizzato con modalità diverse da quanto previsto dal produttore, la sua funzione di protezione potrebbe venire compromessa.

DİKKAT: Bu ürünün kurulumu, yapılandırılması, işletilmesi veya bakımı öncesinde bu dokümanı ve bu ekipmanın kurulumu, yapılandırılması ve işletimi ile ilgili ilave Kaynaklar bölümünde yer listelenmiş dokümanları okuyun. Kullanıcılar yürürlükteki tüm yönetmelikler, yasal ve standartların gereksinimlerine ek olarak kurulum ve kablolama talimatlarını da öğrenmek zorundadır.

Kurulum, ayarlama, hizmete alma, kulllanma, parçaları birleştirme, parçaları sökme ve bakım gibi aktiviteler sadece uygun eğitimli almış kişiler tarafından yürürlükteki uygulama yönetmeliklerine uygun şekilde yapılabilir.

Bu ekipman üretici tarafından belirlenmiş amacın dışında kullanılırsa, ekipman tarafından sağlanan koruma bozulabilir.

注意事項：在安装、設定、操作或維護本產品前，請先閱讀此文件以及列於「其他資源」章節中有關安裝、設定與操作此設備的文件。使用者必須熟悉安裝和配線指示，並符合所有法規、法律和標準要求。

包括安裝、調整、交付使用、使用、組裝、拆卸和維護等動作都必須交由已經適當訓練的人員進行，以符合適用的實作法規。

如果將設備用於非製造商指定的用途時，可能會造成設備所提供的保護功能受損。

POZOR: Než začnete instalovat, konfigurovat či provozovat tento výrobek nebo provádět jeho údržbu, přečtěte si tento dokument a dokumenty uvedené v části Dodatečné zdroje ohledně instalace, konfigurace a provozu tohoto zařízení. Uživatelé se musejí vedle požadavků všech relevantních vyhlášek, zákonů a norem nutně seznámit také s pokyny pro instalaci a elektrické zapojení.

Činnosti zahrnující instalaci, nastavení, uvedení do provozu, užívání, montáž, demontáž a údržbu musí vykonávat vhodné proškolený personál v souladu s příslušnými prováděcími předpisy.

Pokud se toto zařízení používá způsobem neodpovídajícím specifikaci výrobce, může být narušena ochrana, kterou toto zařízení poskytuje.

UWAGA: Przed instalacją, konfiguracją, użytkowaniem lub konserwacją tego produktu należy przeczytać niniejszy dokument oraz wszystkie dokumenty wymienione w sekcji Dodatkowe źródła omawiające instalację, konfigurację i procedury użytkowania tego urządzenia. Użytkownicy mają obowiązek zapoznać się z instrukcjami dotyczącymi instalacji oraz oprzewodowania, jak również z obowiązującymi kodeksami, prawem i normami.

Działania obejmujące instalację, regulację, przekazanie do użytkowania, użytkowanie, montaż, demontaż oraz konserwację muszą być wykonywane przez odpowiednio przeszkolony personel zgodnie z obowiązującym kodeksem postępowania.

Jeśli urządzenie jest użytkowane w sposób inny niż określony przez producenta, zabezpieczenie zapewniane przez urządzenie może zostać ograniczone.

OBŚ! Läs detta dokument samt dokumentet, som står listat i avsnittet Övriga resurser, om installation, konfigurering och drift av denna utrustning innan du installerar, konfigurerar eller börjar använda eller utföra underhållsarbete på produkten. Användare måste bekanta sig med instruktioner för installation och kabeldragning, förutom krav enligt gällande koder, lagar och standarder.

Åtgärder som installation, justering, service, användning, montering, demontering och underhållsarbete måste utföras av personal med lämplig utbildning enligt lämpligt bruk.

Om denna utrustning används på ett sätt som inte anges av tillverkaren kan det hända att utrustningens skyddsanordningar försätts ur funktion.

LET OP: Lees dit document en de documenten die genoemd worden in de paragraaf Aanvullende informatie over de installatie, configuratie en bediening van deze apparatuur voordat u dit product installeert, configureert, bedient of onderhoudt. Gebruikers moeten zich vertrouwd maken met de installatie en de bedradinginstructies, naast de vereisten van alle toepasselijke regels, wetten en normen.

Activiteiten zoals het installeren, afstellen, in gebruik stellen, gebruiken, monteren, demonteren en het uitvoeren van onderhoud mogen uitsluitend worden uitgevoerd door hiervoor opgeleid personeel en in overeenstemming met de geldende praktijkregels.

Indien de apparatuur wordt gebruikt op een wijze die niet is gespecificeerd door de fabrikant, dan bestaat het gevaar dat de beveiliging van de apparatuur niet goed werkt.

Environment and Enclosure



ATTENTION: This equipment is intended for use in a Pollution Degree 2 industrial environment, in overvoltage Category II applications (as defined in EN/IEC 60664-1), at altitudes up to 2000 m (6562 ft) without derating. This equipment is not intended for use in residential environments and may not provide adequate protection to radio communication services in such environments.

This equipment is supplied as open-type equipment for indoor use. It must be mounted within an enclosure that is suitably designed for those specific environmental conditions that are present and appropriately designed to help prevent personal injury resulting from accessibility to live parts. The enclosure must have suitable flame-retardant properties to help prevent or minimize the spread of flame, complying with a flame spread rating of 5VA or be approved for the application if nonmetallic. The interior of the enclosure must be accessible only by the use of a tool. Subsequent sections of this publication may contain more information regarding specific enclosure type ratings that are required to comply with certain product safety certifications.

In addition to this publication, see the following:

- Industrial Automation Wiring and Grounding Guidelines, publication [1770-4.1](#), for additional installation requirements.
- NEMA Standard 250 and EN/IEC 60529, as applicable, for explanations of the degrees of protection provided by enclosures.

Prevent Electrostatic Discharge



ATTENTION: This equipment is sensitive to electrostatic discharge, which can cause internal damage and affect normal operation. Follow these guidelines when you handle this equipment:

- Touch a grounded object to discharge potential static.
- Wear an approved grounding wriststrap.
- Do not touch connectors or pins on component boards.
- Do not touch circuit components inside the equipment.
- Use a static-safe workstation, if available.
- Store the equipment in appropriate static-safe packaging when not in use.



ATTENTION: Special Conditions for Safe Use

- This product is grounded through the DIN rail to chassis ground. Use zinc-plated chromate-passivated steel DIN rail to assure proper grounding. The use of other DIN rail materials (for example, aluminum or plastic) that can corrode, oxidize, or are poor conductors, can result in improper or intermittent grounding. Secure DIN rail to mounting surface approximately every 200 mm (7.8 in.) and use end-anchors appropriately. Be sure to ground the DIN rail properly. See Industrial Automation Wiring and Grounding Guidelines, Rockwell Automation publication [1770-4.1](#), for more information.
- Do not remove or replace an adapter module while power is applied. Interruption of the backplane can result in unintentional operation or machine motion.
- Do not discard the end cap. Use this end cap to cover the exposed interconnections on the last mounting base on the DIN rail. Failure to do so could result in equipment damage or injury from electric shock.
- If this equipment is used in a manner that is not specified by the manufacturer, the protection that is provided by the equipment may be impaired.



ATTENTION:

- This equipment is certified for use only within the surrounding air temperature range of -20...+55 °C (-4...+131°F). The equipment must not be used outside of this range.
- Use only a soft dry anti-static cloth to wipe down equipment. Do not use any cleaning agents.
- Read this document and the documents that are listed in the Additional Resources section about installation, configuration, and operation of this equipment before you install, configure, operate, or maintain this product. Users are required to familiarize themselves with installation and wiring requirements of all applicable codes, laws, and standards.
- When used in a Class I Division 2, hazardous location, this equipment must be mounted in a suitable enclosure with proper wiring method that complies with the governing electrical codes.

North American Hazardous Location Approval

The Following Information Applies When Operating This Equipment In Hazardous Locations.	Informations sur l'utilisation de cet équipement en environnements dangereux.
<p>Products marked "CL I, DIV 2, GP A, B, C, D" are suitable for use in Class I Division 2 Groups A, B, C, D, Hazardous Locations and nonhazardous locations only. Each product is supplied with markings on the rating nameplate indicating the hazardous location temperature code. When combining products within a system, the most adverse temperature code (lowest "T" number) may be used to help determine the overall temperature code of the system. Combinations of equipment in your system are subject to investigation by the local Authority Having Jurisdiction at the time of installation.</p>	<p>Les produits marqués "CL I, DIV 2, GP A, B, C, D" ne conviennent qu'à une utilisation en environnements de Classe I Division 2 Groupes A, B, C, D dangereux et non dangereux. Chaque produit est livré avec des marquages sur sa plaque d'identification qui indiquent le code de température pour les environnements dangereux. Lorsque plusieurs produits sont combinés dans un système, le code de température le plus défavorable (code de température le plus faible) peut être utilisé pour déterminer le code de température global du système. Les combinaisons d'équipements dans le système sont sujettes à inspection par les autorités locales qualifiées au moment de l'installation.</p>
<div data-bbox="134 1654 228 1740" data-label="Image"> </div> <p>WARNING: Explosion Hazard -</p> <ul style="list-style-type: none"> • Do not disconnect equipment unless power has been removed or the area is known to be nonhazardous. • Do not disconnect connections to this equipment unless power has been removed or the area is known to be nonhazardous. Secure any external connections that mate to this equipment by using screws, sliding latches, threaded connectors, or other means provided with this product. • Substitution of components may impair suitability for Class I Division 2. 	<div data-bbox="794 1654 888 1740" data-label="Image"> </div> <p>AVERTISSEMENT: Risque d'Explosion -</p> <ul style="list-style-type: none"> • Couper le courant ou s'assurer que l'environnement est classé non dangereux avant de débrancher l'équipement. • Couper le courant ou s'assurer que l'environnement est classé non dangereux avant de débrancher les connecteurs. Fixer tous les connecteurs externes reliés à cet équipement à l'aide de vis, loquets coulissants, connecteurs filetés ou autres moyens fournis avec ce produit. • La substitution de composants peut rendre cet équipement inadapté à une utilisation en environnement de Classe I Division 2.

Before You Begin

The POINT I/O™ ASCII modules provide a flexible DeviceNet® interface to a wide variety of RS-232, RS-485, and RS-422 ASCII devices. These modules provide the communication connections to the ASCII device.

The 1734-232ASC module connects to the RS-232 network while the 1734-485ASC module connects to the RS-485 or RS-422 network.

POINT I/O RS-232 and RS-485 ASCII Modules

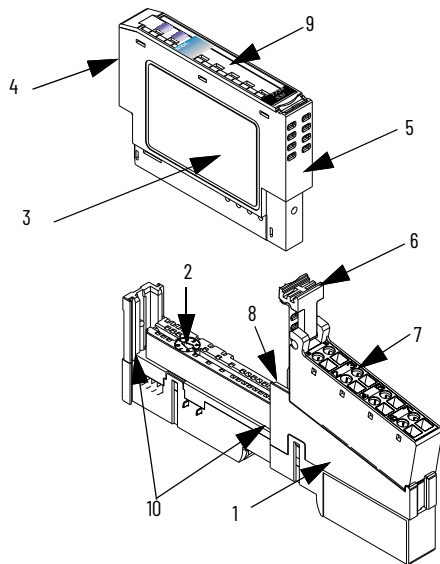

	Description		Description
1	Mounting base ⁽¹⁾	6	Removable Terminal Block (RTB) removal handle
2	Mechanical keying (orange)	7	RTB ⁽¹⁾
3	Module wiring diagram	8	DIN rail locking screw (orange)
4	Module locking mechanism	9	Slide-in writable label
5	Insertable I/O module	10	Interlocking side pieces

(1) Wiring base assembly consists of mounting base 1734-MB, and removable terminal block, 1734-RTB.

Install the Mounting Base

To install the mounting base on the DIN rail, proceed as follows:

1. Position the mounting base vertically above the installed units (adapter, power supply, or existing module).

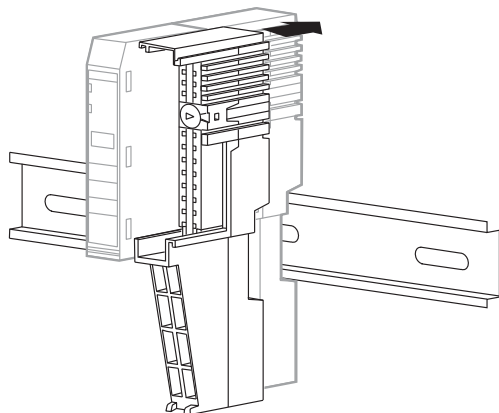

2. Slide the mounting base down allowing the interlocking side pieces to engage the adjacent module or adapter.
3. Press firmly to seat the mounting base on the DIN rail. The mounting base snaps into place. Be sure that the orange DIN rail locking screw is in the horizontal position and that it has engaged the DIN rail.



ATTENTION: Use the end cap from your adapter or interface module to cover the exposed interconnections on the last mounting base on the DIN rail. Failure to do so could result in equipment damage or injury from electric shock.

Install the I/O Module

The module can be installed before or after base installation. Make sure that the mounting base is correctly keyed before installing the module into the mounting base. In addition, make sure the mounting base locking screw is positioned horizontally referenced to the base.



WARNING: If you insert or remove the module while backplane power is on, an electric arc can occur. This could cause an explosion in hazardous location installations. Be sure that power is removed or the area is nonhazardous before proceeding.

POINT I/O Terminal Bases

1734-TB Base

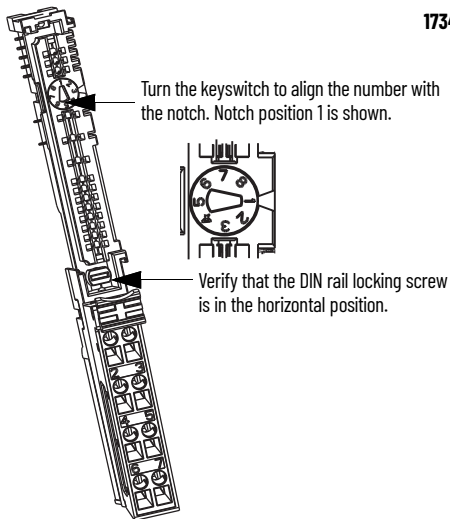

1734-TOP Base

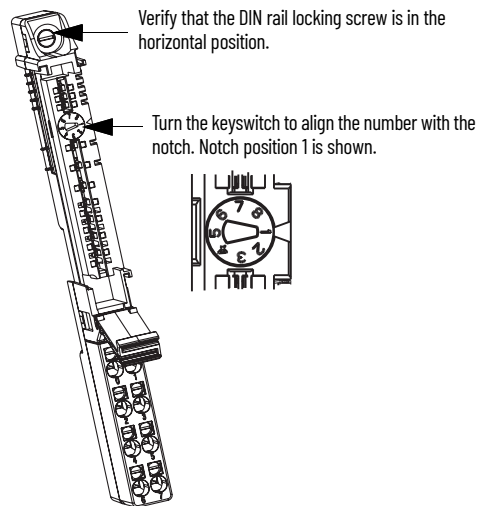

To install the module, proceed as follows:

1. Use a bladed screwdriver to rotate the keyswitch (2) on the mounting base clockwise until the number required for the type of module being installed aligns with the notch in the base.
2. Verify that the DIN rail locking screw is in the horizontal position. You cannot insert the module if the locking mechanism is unlocked.
3. Insert the module straight down into the mounting base and press to secure. The module locks into place.

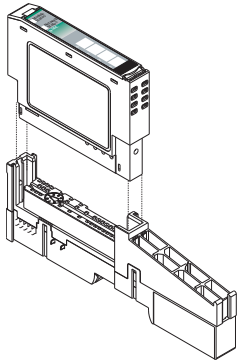

Install the Removable Terminal Block

An RTB is supplied with your wiring base assembly. To remove, pull up on the RTB handle. This allows the mounting base to be removed and replaced as necessary without removing any of the wirings. To reinsert the RTB, proceed as follows.



WARNING: When you connect or disconnect the Removable Terminal Block (RTB) with field-side power applied, an electric arc can occur. This can cause an explosion in hazardous location installations. Be sure that power is removed or the area is nonhazardous before proceeding.

1. Insert the end opposite the handle into the base unit. This end has a curved section that engages with the wiring base.
2. Rotate the terminal block into the wiring base until it locks itself in place.
3. If an I/O module is installed, snap the RTB handle into place on the module.

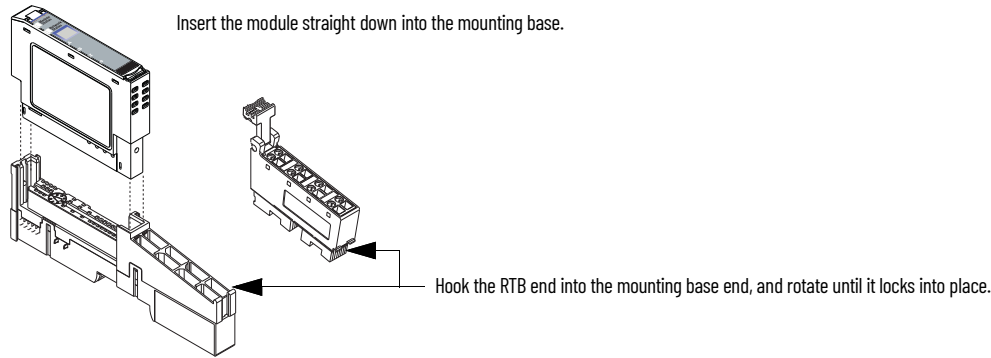

WARNING: For 1734-RTBS and 1734-RTB3S, to latch and unlatch the wire, insert a bladed screwdriver (catalog number 1492-N90 - 3 mm [0.12 in.] diameter blade) into the opening at approximately 73° (blade surface is parallel with top surface of the opening) and push up gently.

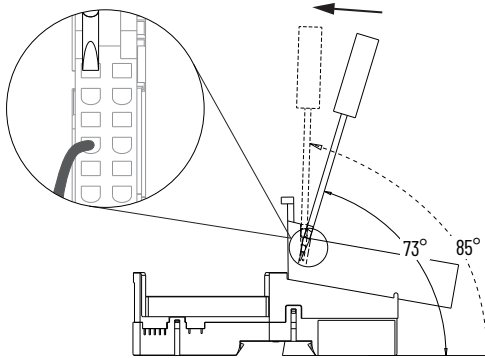

WARNING: For 1734-TOPS and 1734-TOP3S, to latch and unlatch the wire, insert a bladed screwdriver (catalog number 1492-N90 - 3 mm [0.12 in.] diameter blade) into the opening at approximately 97° (blade surface is parallel with top surface of the opening) and press in (do not push up or down).

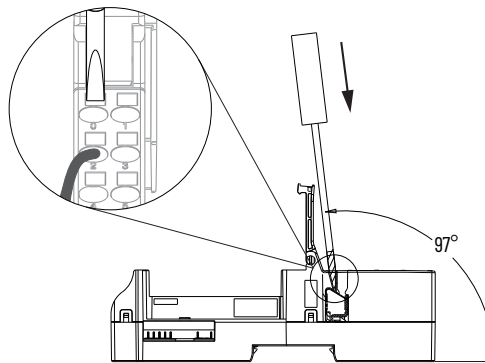

Remove a Mounting Base

To remove a mounting base, you must remove any installed module, and remove the RTB (if wired).

1. Unlatch the RTB handle on the I/O module.
2. Pull on the RTB handle to remove the removable terminal block.
3. Press the module lock on the top of the module.
4. Pull on the I/O module to remove from the base.
5. Use a small bladed screwdriver to rotate the orange base locking screw to a vertical position. This releases the locking mechanism.
6. Lift straight up to remove.

Wire the Module

To wire the module, see [Figure 1](#), [Figure 2](#), and [Table 1](#).

Figure 1 - 1734-232ASC Module

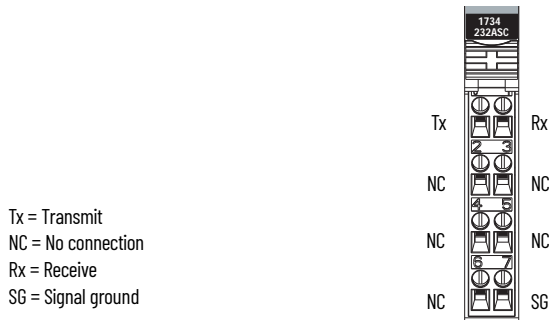

IMPORTANT Shielded Cable: The 1734-232ASC module requires shielded cable to help reduce the effects of electrical noise coupling. Ground each shield at one end only. A shield grounded at both ends forms a ground loop, which can cause module communications to fault. Never connect a shield to the common side of a logic circuit. This would introduce noise into the logic circuit.

Connect the shield directly to a chassis ground. This chassis ground connection is not available on the 1734-232ASC RTB. On a POINT I/O system, the chassis ground connection can be made at the DIN rail, at the metal panel the DIN rail is mounted to, or at the I/O device.

Figure 2 - 1734-485ASC Module

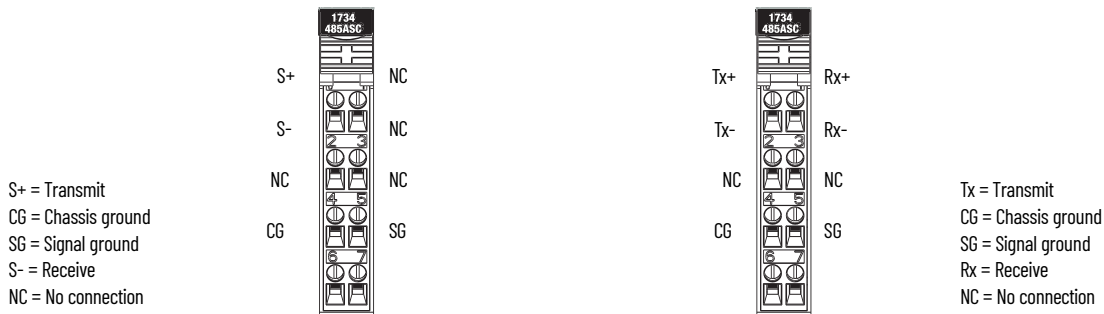

IMPORTANT Shielded Cable: The 1734-485ASC module requires shielded cable to help reduce the effects of electrical noise coupling. Ground each shield at one end only. A shield grounded at both ends forms a ground loop, which can cause module communications to fault. Never connect a shield to the common side of a logic circuit. This would introduce noise into the logic circuit.

Connect the shield directly to a chassis ground. This chassis ground connection is not available on the 1734-485ASC RTB. On a POINT I/O system, the chassis ground connection can be made at the DIN rail, at the metal panel the DIN rail is mounted to, or at the I/O device.

Table 1 - POINT I/O ASCII Module Terminations

Terminal	RS-232	RS-485	RS-422
0	Tx ⁽¹⁾	S+ ⁽¹⁾	Tx+ ⁽¹⁾
1	Rx ⁽²⁾	NC	Rx+ ⁽¹⁾
2	NC	S- ⁽²⁾	Tx- ⁽²⁾
3	NC	NC	Rx- ⁽²⁾
4	NC	NC	NC
5	NC	NC	NC
6	NC	CG	CG
7	SG	SG	SG

(1) S+ and Tx+ are transmitted from the module.

(2) S- and Rx- are received by the module.



WARNING: If you connect or disconnect the serial cable with power applied to this module or the serial device on the other end of the cable, an electric arc can occur. This could cause an explosion in hazardous location installations. Be sure that power is removed or the area is nonhazardous before proceeding.

Communicate with Your Module

Read this section for information about how to communicate with your module.

The ASCII modules operate as the POINTBus™ front end to your serial device. Data can be exchanged with the master through a polled, cyclic, or change-of-state connection. Bit-Strobe Command Response Messaging and the Unconnected Message Manager (UCMM) are not supported. The module produces and consumes data as shown in [Table 2](#):

Table 2 - POINT I/O ASCII Module Produce/Consume

I/O Connection Type	Consumes	Produces
Polled	4...132 bytes	4...132 bytes
Cyclic	4...132 bytes	4...132 bytes
Change-of-state	4...132 bytes	4...132 bytes



ATTENTION: The ASCII modules are not compatible with the 1734-APB PROFIBUS adapter.

Interpret Status Indicators

See [Figure 3](#) and [Table 3](#) for information on how to interpret the status indicators.

Figure 3 - POINT I/O RS-232 and RS-485 ASCII Modules

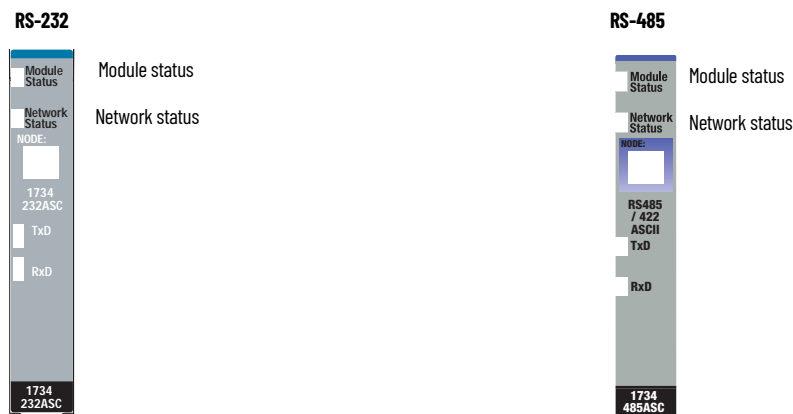

Table 3 - Indicator Status for 1734-232ASC, 1734-485ASC, 1734-485ASCK Modules

	Status	Description
Module status	Off	No power is applied to the device.
	Green	The device is operating normally.
	Flashing green	The device needs commissioning due to configuration missing, incomplete, or incorrect.
	Red	An unrecoverable fault that may require device replacement.
	Flashing red	A recoverable fault is present.
	Flashing red/green	The device is in self-test mode.
Network status	Off	The device is not online: - The device has not completed the dup_MAC-id test. - The device is not powered - Check the module status indicator.
	Green	The device is online and has connections in the established state.
	Flashing green	The device is online but has no connections in the established state.
	Red	Critical link failure - Failed communication device. The device has detected an error that prevents it from communicating on the network.
	Flashing red	One or more I/O connections are in timed-out state.
	Flashing red/green	Communication faulted device - The device has detected a network access error and is in a communication faulted state. The device has received and accepted an Identity Communication Faulted Request - Long protocol message.

Table 3 - Indicator Status for 1734-232ASC, 1734-485ASC, 1734-485ASCK Modules (Continued)

	Status	Description
Transmit/Receive status	Flashing transmit/receive	Check wiring, ground, and Rx connection. Access the user parameter object to view record numbers.
	Flashing receive/off transmit	<ul style="list-style-type: none"> - Check the wiring. - Watch the Tx indicator. If the Tx indicator does not flash, verify that you are properly initiating transmission. <ul style="list-style-type: none"> - Use the EDS parameter object to try transmitting. - Watch the indicator. If the indicator flashes, you are not properly initiating transmission through I/O messaging. If it flashes, check the remote device.
	Off transmit/green receive	Possible reverse wiring to the device. Check the connections.

Specifications

General Specifications – 1734-232ASC, 1734-485ASC, 1734-485ASCK

Attribute	Value
Number of inputs	1, full-duplex
Module location	1734-TB or 1734-TBS wiring base assembly
Input voltage, signal with respect to Signal Ground (SG) "0", asserted, ON, space, active	3...25V DC
Input voltage, signal with respect to Signal Ground (SG) "1", disasserted, OFF, mark, Inactive	-3...+25V DC
Indicators	1 green/red module 1 green/red network 2 green TXD, RXD
Keyswitch position	2 (specialty)
External DC power, supply voltage, nom	24V DC
External DC power, voltage range	10...28.8V DC
External DC power, supply current	15 mA @ 24V DC, fault protected to 28.8V DC
Dimensions, approx., HxWxD	56 x 12 x 75.5 mm (2.21 x 0.47 x 2.97 in.)
Weight, approx.	28 g (0.99 oz)
POINTBus current, max	75 mA @ 5V DC
Power dissipation, max	0.75 W @ 28.8V DC
Thermal dissipation, max	2.5 BTU/hr @ 28.8V DC
Isolation voltage	Type tested at 2200V DC for 60 s No isolation between individual channels
Enclosure type rating	None (open-style)
Wiring category ⁽¹⁾	2 - on communications ports
Wire size	0.25...2.5 mm ² (24...14 AWG) shielded solid or stranded copper wire rated at 75 °C (167 °F) or greater 1.2 mm (3/64 in.) insulation
Terminal base wiring torque, max	0.6 N•m (7 lb•in)
North American temp code	T4A

(1) Use this Conductor Category information for planning conductor routing as described in the appropriate System Level Installation Manual. See Industrial Automation Wiring and Grounding Guidelines, publication [1770-4.1](#), for more information.

Serial Port Specifications

Attribute	Value
Serial Port Parameters	
Serial character framing	7N2, 7E1, 7O1, 8N1, 8N2, 8E1, 8O1, 7E2, 7O2
Serial port comm speed	1200, 2400, 4800, 9600, 19.2k, 38.4k
Serial Port Receive from ASCII Device	
Number of receive characters, max	1...128
Receive record start mode	No, Exclude, Include start delimiter
Receive record delimiter	ASCII character

Serial Port Specifications (Continued)

Attribute	Value
Receive record end mode	No, Exclude, Include start delimiter
Receive end delimiter	ASCII character
Send (Produce) on DeviceNet to Master	
Receive string data type	Array, short_string, string
Pad mode	Pad mode disabled, Enabled
Pad character	ASCII character
Receive swap mode	Disabled, 16-bit, 24-bit, 32-bit swap
DeviceNet handshake mode	Master/slave handshake, Produce immediate
Produce assembly size	4...132
Serial data	0...128 bytes
Receive transaction ID	0...255
Serial Port Transmit to ASCII Device	
Number of transmit characters, max	1...128
Transmit end delimiter mode	No, Exclude, Include end delimiter
Transmit end delimiter character	ASCII
Consume on DeviceNet from Master	
Consume string data type	Array, short_string, string
Transmit swap mode	Disabled, 16-bit, 24-bit, 32-bit swap
DeviceNet record header mode	Transmit handshake, Immediate
Consume assembly size	4...132
Serial Port Transmit/Explicit Messages	
Transmit serial data string	0...128 bytes
Transmitted serial data length	0...128 bytes
Transmit transaction ID	0...255
Status	TX FIFO overflow, RX FIFO overflow, RX parity error, Handshake error, New data flag

Environmental Specifications

Attribute	Value
Temperature, operating	IEC 60068-2-1 (Test Ad, operating cold), IEC 60068-2-2 (Test Bd, operating dry heat), IEC 60068-2-14 (Test Nb, operating thermal shock): -20 °C < Ta < +55 °C (-4 °F < Ta < +131 °F)
Temperature, nonoperating	IEC60068-2-1 (Test Ad, Non-operating Cold), IEC60068-2-2, (Test Bd, Non-operating Dry Heat), -40...+85 °C (-40...+185 °F)
Temperature, surrounding air, max	55 °C (131 °F)
Relative humidity	IEC 60068-2-30 (Test Db, Un-packaged Non-operating Damp Heat): 5...95 % non-condensing
Shock, operating	IEC 60068-2-27 (Test Ea, unpackaged shock): 30 g
Shock, nonoperating	IEC 60068-2-27 (Test Ea, unpackaged shock): 50 g
Vibration	IEC 60068-2-6 (Test Fc, operating) 5 g @ 10...500 Hz
Emissions	IEC 61000-6-4
ESD immunity	IEC 61000-4-2: 6 kV contact discharges 8 kV air discharges

Environmental Specifications (Continued)

Attribute	Value
Radiated RF immunity	IEC 61000-4-3: 10V/m with 1 kHz sine-wave 80% AM from 80...6000 MHz
EFT/B immunity	IEC 61000-4-4: ±2 kV at 5 kHz on communications ports
Surge transient immunity	IEC 61000-4-5: ±2 kV line-earth (CM) on communications ports
Conducted RF immunity	IEC 61000-4-6: 10V rms with 1 kHz sine-wave 80% AM from 150 kHz...80 MHz

Certifications

Certification (when product is marked) ⁽¹⁾	Value
c-UL-us	UL Listed Industrial Control Equipment, certified for US and Canada. See UL File E322657. UL Listed for Class I, Division 2 Group A, B, C, D Hazardous Locations, certified for U.S. and Canada. See UL File E334470.
CE	European Union 2014/30/EU EMC Directive, compliant with: EN 61326-1; Meas./Control/Lab., Industrial Requirements EN 61000-6-2; Industrial Immunity EN 61000-6-4; Industrial Emissions EN 61131-2; Programmable Controllers (Clause 8, Zone A & B) European Union 2011/65/EU RoHS, compliant with: EN IEC 63000; Technical documentation
RCM	Australian Radiocommunications Act, compliant with: AS/NZS CISPR 11; Industrial Emissions
KC	Korean Registration of Broadcasting and Communications Equipment, compliant with: Article 58-2 of Radio Waves Act, Clause 3
Morocco	Arrêté ministériel n° 6404-15 du 29 ramadan 1436
UKCA	2016 No. 1091 - Electromagnetic Compatibility Regulations 2012 No. 3032 - Restriction of the Use of Certain Hazardous Substances in Electrical and Electronic Equipment Regulations

(1) See the Product Certification link at rok.auto/certifications for Declaration of Conformity, Certificates, and other certification details.

Additional Resources

For more information on the products that are described in this publication, use these resources. You can view or download publications at rok.auto/literature.

Resource	Description
POINT I/O Modules Selection Guide, publication 1734-SG001	Provides information on how to select POINT I/O adapters, terminal bases, I/O modules, and accessories.
POINT I/O ASCII Modules User Manual, publication 1734-UM009	Provides a detailed description of module functionality, configuration, and usage for POINT I/O ASCII modules.
Industrial Automation Wiring and Grounding Guidelines, publication 1770-4.1	More information on proper wiring and grounding techniques.
Product Certifications website, rok.auto/certifications	Provides declarations of conformity, certificates, and other certification details.

Rockwell Automation Support

Use these resources to access support information.

Technical Support Center	Find help with how-to videos, FAQs, chat, user forums, Knowledgebase, and product notification updates.	rok.auto/support
Local Technical Support Phone Numbers	Locate the telephone number for your country.	rok.auto/phonesupport
Technical Documentation Center	Quickly access and download technical specifications, installation instructions, and user manuals.	rok.auto/techdocs
Literature Library	Find installation instructions, manuals, brochures, and technical data publications.	rok.auto/literature
Product Compatibility and Download Center (PCDC)	Download firmware, associated files (such as AOP, EDS, and DTM), and access product release notes.	rok.auto/pcdc

Documentation Feedback

Your comments help us serve your documentation needs better. If you have any suggestions on how to improve our content, complete the form at rok.auto/docfeedback.





Waste Electrical and Electronic Equipment (WEEE)



At the end of life, this equipment should be collected separately from any unsorted municipal waste.

Rockwell Automation maintains current product environmental compliance information on its website at rok.auto/pec.

Rockwell Otomasyon Ticaret A.Ş. Kar Plaza İş Merkezi E Blok Kat:6 34752 İçerenköy, İstanbul, Tel: +90 (216) 5698400 EEE Yönetmeliğine Uygundur

Connect with us.    

rockwellautomation.com — expanding **human possibility**[®]

AMERICAS: Rockwell Automation, 1201 South Second Street, Milwaukee, WI 53204-2496 USA, Tel: (1) 414.382.2000

EUROPE/MIDDLE EAST/AFRICA: Rockwell Automation NV, Pegasus Park, De Kleetlaan 12a, 1831 Diegem, Belgium, Tel: (32) 2663 0600

ASIA PACIFIC: Rockwell Automation SEA Pte Ltd, 2 Corporation Road, #04-05, Main Lobby, Corporation Place, Singapore 618494, Tel: (65) 6510 6608

UNITED KINGDOM: Rockwell Automation Ltd., Pitfield, Kiln Farm, Milton Keynes, MK11 3DR, United Kingdom, Tel: (44)(1908) 838-800

Allen-Bradley, expanding human possibility, FactoryTalk, POINT I/O, POINTBus, Rockwell Automation, and TechConnect are trademarks of Rockwell Automation, Inc.

DeviceNet is a trademark of ODVA, Inc.

Trademarks not belonging to Rockwell Automation are property of their respective companies.

Publication 1734-IN588D-EN-P - March 2024 | Supersedes Publication 1734-IN588C-EN-P - August 2022

Copyright © 2024 Rockwell Automation, Inc. All rights reserved.