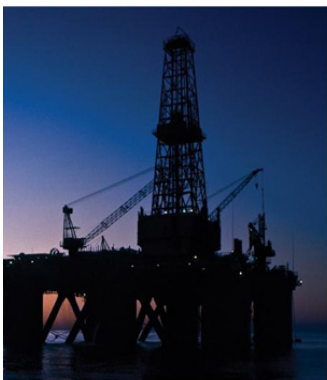
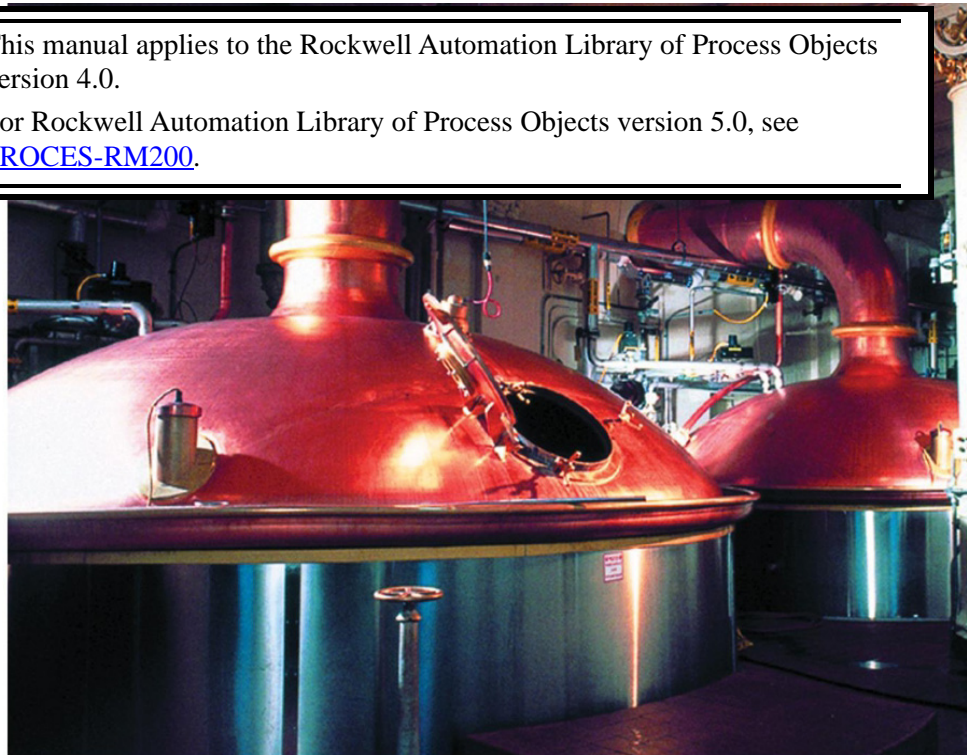
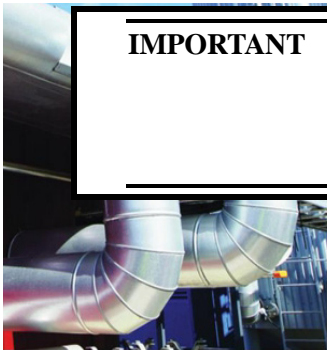


# Rockwell Automation Library of Process Objects: Display Elements

Version 4.0

**IMPORTANT** This manual applies to the Rockwell Automation Library of Process Objects version 4.0.

For Rockwell Automation Library of Process Objects version 5.0, see [PROCES-RM200](#).



# Important User Information

Read this document and the documents listed in the additional resources section about installation, configuration, and operation of this equipment before you install, configure, operate, or maintain this product. Users are required to familiarize themselves with installation and wiring instructions in addition to requirements of all applicable codes, laws, and standards.

Activities including installation, adjustments, putting into service, use, assembly, disassembly, and maintenance are required to be carried out by suitably trained personnel in accordance with applicable code of practice.

If this equipment is used in a manner not specified by the manufacturer, the protection provided by the equipment may be impaired.

In no event will Rockwell Automation, Inc. be responsible or liable for indirect or consequential damages resulting from the use or application of this equipment.

The examples and diagrams in this manual are included solely for illustrative purposes. Because of the many variables and requirements associated with any particular installation, Rockwell Automation, Inc. cannot assume responsibility or liability for actual use based on the examples and diagrams.

No patent liability is assumed by Rockwell Automation, Inc. with respect to use of information, circuits, equipment, or software described in this manual.

Reproduction of the contents of this manual, in whole or in part, without written permission of Rockwell Automation, Inc., is prohibited

Throughout this manual, when necessary, we use notes to make you aware of safety considerations.



**WARNING:** Identifies information about practices or circumstances that can cause an explosion in a hazardous environment, which may lead to personal injury or death, property damage, or economic loss.



**ATTENTION:** Identifies information about practices or circumstances that can lead to personal injury or death, property damage, or economic loss. Attentions help you identify a hazard, avoid a hazard, and recognize the consequence.

---

**IMPORTANT** Identifies information that is critical for successful application and understanding of the product.

---

Labels may also be on or inside the equipment to provide specific precautions.



**SHOCK HAZARD:** Labels may be on or inside the equipment, for example, a drive or motor, to alert people that dangerous voltage may be present.



**BURN HAZARD:** Labels may be on or inside the equipment, for example, a drive or motor, to alert people that surfaces may reach dangerous temperatures.



**ARC FLASH HAZARD:** Labels may be on or inside the equipment, for example, a motor control center, to alert people to potential Arc Flash. Arc Flash will cause severe injury or death. Wear proper Personal Protective Equipment (PPE). Follow ALL Regulatory requirements for safe work practices and for Personal Protective Equipment (PPE).

---

	<b>Preface</b> .....	<b>15</b>
	Access the Attachments.....	16
	Open Content .....	16
	How to Use Attachments .....	17
	Additional Resources.....	18
	Summary of Changes .....	18
	 <b>Chapter 1</b>	
<b>Overview</b>	Required Files.....	20
	Basic Attributes and Indicators.....	22
	State Indicators .....	23
	Status/Quality Indicators .....	23
	Threshold Indicators .....	25
	Deviation Indicators.....	26
	Command Source Indicators .....	26
	Maintenance Bypass Indicator.....	28
	Help Files.....	29
	Basic Faceplate Attributes.....	32
	Quick Display Interaction .....	39
	Using a Display Element.....	40
	 <b>Chapter 2</b>	
<b>Cross Functional Family</b>	Condition Gate Delay (P_Gate).....	43
	Display Elements.....	43
	Faceplate .....	44
	Interlocks with First Out and Bypass (P_Intlk) .....	45
	Display Elements.....	45
	Operator Tab .....	47
	Maintenance Tab.....	49
	Advanced Properties Display .....	50
	Interlocks with First Out and Bypass - Advanced (P_IntlkAdv) ...	53
	Operator Tab .....	53
	Maintenance Tab.....	54
	HMI Configuration Tab.....	55
	Engineering Tab.....	57
	Permissives with Bypass (P_Perm).....	58
	Display Elements.....	58
	Operator Tab .....	60
	Maintenance Tab.....	61
	Advanced Properties Display .....	62
	Central Reset (P_Reset) .....	65
	Graphic Symbols .....	65
	Common Alarm Block (P_Alarm).....	66
	Command Source (P_CmdSrc) .....	71
	Command Source Totem Pole.....	72

Operator Buttons .....	72
Maintenance Buttons .....	74
Advanced Properties .....	75
Operator Prompt (P_Prompt) .....	76
Graphic Symbols .....	76
Faceplates .....	77
Boolean Logic with Snapshot (P_Logic) .....	81
Display Elements .....	81
Operator Tab .....	82
View Snapshot Tab .....	83
Maintenance Tab .....	84
Advanced Properties Display .....	85
Gate Configuration Display .....	87

### Chapter 3

## I/O Processing Family

Display Elements .....	91
Trends Tab .....	93
Basic Analog Input (P_AIn) .....	94
Operator (Home) Tab .....	94
Maintenance Tab .....	95
Advanced Properties Display .....	97
Diagnostics Tab .....	100
Alarms Tab .....	100
Advanced Analog Input (P_AInAdv) .....	101
Display Elements .....	101
Operator Tab .....	103
Maintenance Tab .....	104
Advanced Properties Display .....	106
Diagnostics Tab .....	109
Alarms Tab .....	109
Analog Input Channel (P_AInChan) .....	110
Display Elements .....	110
Operator Tab .....	110
Maintenance Tab .....	111
Advanced Properties Display .....	112
Alarms Tab .....	116
Dual Sensor Analog Input (P_AInDual) .....	117
Display Elements .....	117
Operator Tab .....	117
Maintenance Tab .....	118
Advanced Properties Display .....	119
Diagnostics Tab .....	123
Alarms Tab .....	123
Multiple Analog Input (P_AInMulti) .....	124
Display Elements .....	124
Operator Tab .....	126
Maintenance Tab .....	127

Advanced Properties Display .....	129
Diagnostics Tab .....	134
Alarms Tab .....	134
Discrete Input (P_DIn).....	135
Display Elements .....	135
Operator Tab .....	136
Maintenance Tab.....	137
Advanced Properties Display .....	138
Alarms Tab .....	140
Digital Input Advanced (P_DInAdv) .....	141
Display Elements .....	141
Operator Tab .....	142
Maintenance Tab.....	143
Advanced Properties Display .....	144
Alarms Tab .....	148
Discrete Output (P_DOut).....	150
Display Elements .....	150
Operator Tab .....	151
Maintenance Tab.....	152
Advanced Properties Display .....	153
Diagnostics Tab .....	157
Alarms Tab .....	157
Analog Output (P_AOut) .....	158
Display Elements .....	158
Operator Tab .....	159
Maintenance Tab.....	160
Advanced Properties Display .....	161
Diagnostics Tab .....	165
Alarms Tab .....	165
Pressure/Temperature Compensated Flow (P_PTComp) .....	166
Tank Strapping Table (P_StrapTbl) .....	166

## Chapter 4

### Regulatory and Procedural Control Family

Proportional + Integral + Derivative Enhanced (P_PIDE).....	168
Display Elements .....	168
Operator (Home) Tab .....	171
Maintenance Tab.....	173
Advanced Properties.....	174
Diagnostics Tab .....	190
Alarms Tab .....	190
Trends .....	191
Analog Fanout (P_Fanout) .....	192
Display Elements .....	192
Operator Tab .....	193
Maintenance Tab.....	194
Advanced Properties Display .....	195
Engineering Tab.....	195

HMI Configuration Tab.....	197
Diagnostics Tab.....	199
Alarms Tab.....	199
High or Low Selector (P_HiLoSel).....	200
Display Elements.....	200
Operator Tab.....	201
Maintenance Tab.....	202
Advanced Properties Display.....	203
Engineering Tab.....	203
HMI Configuration Tab.....	204
Diagnostics Tab.....	206
Alarms Tab.....	206
Deadband Controller (P_DBC).....	207
Display Elements.....	207
Operator Tab.....	208
Maintenance Tab.....	209
Advanced Properties Display.....	210
Engineering Tab.....	210
HMI Configuration Tab.....	212
Diagnostics Tab.....	213
Alarms Tab.....	213
Rockwell Automation Sequencer Object (P_Seq).....	214
Operator Tab.....	214
Maintenance Tab.....	215
Advanced Properties Display.....	216
Advanced Maintenance Tab.....	216
Engineering Tab.....	219
HMI Configuration Tab.....	225
Diagnostics Tab.....	226
Alarms Tab.....	226
Dosing (P_Dose).....	227
Display Elements.....	227
Operator Tab.....	229
Maintenance Tab.....	230
Advanced Properties Display.....	231
Advanced Maintenance Tab.....	231
Engineering Tab.....	232
HMI Configuration Tab.....	235
Diagnostics Tab.....	236
Alarms Tab.....	236
Lead/Lag/Standby Motor Group (P_LLS).....	237
Display Elements.....	237
Operator Tab.....	238
Maintenance Tab.....	239
Advanced Properties Display.....	240
Engineering Tab.....	241
Motor Configuration Dialog Box.....	243

**Motors Family**

HMI Configuration Tab.....	244
Diagnostics Tab.....	245
Alarms Tab.....	245
<b>Chapter 5</b>	
Common Motors Faceplates.....	247
Single-speed Motor (P_Motor).....	250
Display Elements (P_Motor).....	250
Operator Tab.....	252
Maintenance Tab.....	252
Advanced Properties Display.....	253
Diagnostics Tab.....	257
Alarms Tab.....	257
Two-speed Motor (P_Motor2Spd).....	258
Display Elements (P_Motor2Spd).....	258
Operator Tab.....	259
Maintenance Tab.....	260
Advanced Properties Display.....	261
HMI Configuration Tab.....	264
Diagnostics Tab.....	266
Alarms Tab.....	266
Reversing Motor (P_MotorRev).....	267
Display Elements (P_MotorRev).....	267
Operator Tab.....	268
Maintenance Tab.....	269
Advanced Properties Display.....	270
Diagnostics Tab.....	275
Alarms Tab.....	275
Hand-operated Motor (P_MotorHO).....	276
Display Elements (P_MotorHO).....	276
Operator Tab.....	279
Maintenance Tab.....	280
Advanced Properties Display.....	281
Advanced Maintenance Tab.....	281
Engineering Tab.....	282
HMI Configuration Tab.....	283
Diagnostics Tab.....	285
Alarms Tab.....	285
Discrete 2-, 3-, 4-state Device (P_D4SD).....	286
Display Elements (P_D4SD).....	286
Operator Tab.....	290
Maintenance Tab.....	291
Advanced Properties Display.....	292
Advanced Maintenance Tab.....	292
Engineering Tab.....	293
HMI Configuration Tab.....	296
Diagnostics Tab.....	298

Alarms Tab .....	298
Variable Speed Drive (P_VSD) .....	299
Display Elements (P_VSD) .....	299
Operator Tab .....	302
Maintenance Tab .....	303
Advanced Properties Display .....	304
Advanced Maintenance Tab .....	304
Engineering Tab .....	305
HMI Configuration Tab .....	310
Diagnostics Tab .....	313
Alarms Tab .....	313
PowerFlex 523/525 Variable Frequency Drives (P_PF52x) .....	314
Display Elements (P_PF52x) .....	314
Operator Tab .....	315
Maintenance Tab .....	316
Advanced Properties Display .....	317
Advanced Maintenance Tab .....	317
Engineering Tab .....	318
HMI Configuration Tab .....	322
Trends Tab .....	325
Alarms Tab .....	325
PowerFlex 753 Drive (P_PF753) .....	326
Display Elements (P_PF753) .....	326
Operator Tab .....	327
Maintenance Tab .....	328
Advanced Properties Display .....	329
Advanced Maintenance Tab .....	329
Engineering Tab .....	330
HMI Configuration Tab .....	334
Diagnostics Tab .....	336
Alarms Tab .....	336
Trends Tab .....	336
PowerFlex 755 Drive (P_PF755) .....	337
Display Elements (P_PF755) .....	337
Operator Tab .....	337
Maintenance Tab .....	338
Advanced Properties Display .....	339
Advanced Maintenance Tab .....	339
Engineering Tab .....	340
HMI Configuration Tab .....	344
Diagnostics Tab .....	346
Alarms Tab .....	346
Trends Tab .....	346
PowerFlex 6000 Drive (P_PF6000) .....	347
Display Elements (P_PF6000) .....	347
Operator Tab .....	347
Maintenance Tab .....	348



Advanced Properties Display .....	348
Advanced Maintenance Tab.....	349
Engineering Tab.....	350
Diagnostics Tab .....	355
Alarms Tab .....	355
Trends Tab .....	355
PowerFlex 7000 Drive (P_PF7000).....	356
Display Elements (P_PF7000).....	356
Operator Tab .....	356
Maintenance Tab.....	357
Advanced Properties Display .....	357
Advanced Maintenance Tab.....	358
Engineering Tab.....	359
Diagnostics Tab .....	365
Alarms Tab .....	365
Trends Tab .....	365
SMC-50 Smart Motor Controller (P_SMC50) .....	366
Display Elements (P_SMC50).....	366
Operator Tab .....	368
Maintenance Tab.....	369
Advanced Properties Display .....	370
Advanced Maintenance Tab.....	370
Engineering Tab.....	371
HMI Configuration Tab.....	373
Diagnostics Tab .....	375
Alarms Tab .....	375
SMC Flex Smart Motor Controller (P_SMCFlex) .....	376
Display Elements .....	376
Operator Tab .....	376
Maintenance Tab.....	377
Advanced Properties Display .....	378
Advanced Maintenance Tab.....	378
Engineering Tab.....	379
HMI Configuration Tab.....	381
Diagnostics Tab .....	382
Alarms Tab .....	382
E1 Plus Electronic Overload Relay (EtherNet/IP) (P_E1PlusE) ..	383
Display Elements (EtherNet/IP) (P_E1PlusE).....	383
Operator Tab .....	384
Maintenance Tab.....	385
Advanced Properties Display .....	386
Advanced Maintenance Tab.....	386
Engineering Tab.....	387
HMI Configuration Tab.....	388
Diagnostics Tab .....	389
Alarms Tab .....	389
E3/E3 Plus Overload Relay (P_E3Ovld) .....	390

Display Elements .....	390
Operator Tab .....	390
Maintenance Tab.....	391
Advanced Properties Display .....	392
Advanced Maintenance Tab.....	392
Engineering Tab.....	393
HMI Configuration Tab.....	394
Diagnostics Tab .....	395
Alarms Tab .....	395
E300 Electronic Overload Relay (EtherNet/IP) (P_E300Ovld) ..	396
Display Elements .....	396
Operator Tab .....	396
Maintenance Tab.....	397
Advanced Properties Display .....	398
Advanced Maintenance Tab.....	398
Engineering Tab.....	402
HMI Configuration Tab.....	403
Diagnostics Tab .....	404
Alarms Tab .....	404
Run Time and Start Counter (P_RunTime).....	405
Display Elements .....	405
Operator Tab .....	406
Advanced Properties Display .....	406
Restart Inhibit for Large Motor (P_ResInh) .....	407
Display Elements .....	407
Operator Tab .....	408
Advanced Properties Display .....	409

## Chapter 6

### Valves Family

Common Valves Faceplates .....	411
Analog/Pulsed Control Valve (P_ValveC) .....	413
Display Elements .....	413
Operator Tab .....	414
Maintenance Tab.....	415
Advanced Properties Display .....	417
Advanced Maintenance Tab.....	417
Engineering Tab.....	419
HMI Configuration Tab.....	422
Diagnostics Tab .....	423
Alarms Tab .....	423
Hand-operated Valve (P_ValveHO) .....	424
Display Elements .....	424
Operator Tab .....	425
Maintenance Tab.....	426
Advanced Properties Display .....	427
Advanced Maintenance Tab.....	427
Engineering Tab.....	428

HMI Configuration Tab.....	430
Diagnostics Tab.....	431
Alarms Tab.....	431
Motor-operated Valve (P_ValveMO).....	432
Display Elements.....	432
Operator Tab.....	433
Maintenance Tab.....	433
Advanced Properties Display.....	434
Advanced Maintenance Tab.....	434
Engineering Tab.....	435
HMI Configuration Tab.....	437
Diagnostics Tab.....	439
Alarms Tab.....	439
Mix-proof Valve (P_ValveMP).....	440
Display Elements.....	440
Operator Tab.....	441
Maintenance Tab.....	442
Advanced Properties Display.....	443
Advanced Maintenance Tab.....	443
HMI Configuration Tab.....	447
Diagnostics Tab.....	449
Alarms Tab.....	449
Advanced Mix-proof Valve (P_ValveMPAdv).....	450
Display Elements.....	450
Operator Tab.....	451
Maintenance Tab.....	452
Advanced Properties Display.....	453
Advanced Maintenance Tab.....	453
HMI Configuration Tab.....	457
Diagnostics Tab.....	459
Alarms Tab.....	459
Solenoid-operated Valve (P_ValveSO).....	460
Display Elements.....	460
Operator Tab.....	461
Maintenance Tab.....	462
Advanced Properties Display.....	463
Advanced Maintenance Tab.....	463
Engineering Tab.....	464
HMI Configuration Tab.....	466
Diagnostics Tab.....	468
Alarms Tab.....	468
2-state Valve Statistics (P_ValveStats).....	469
Display Elements.....	469
Operator Tab.....	470
Advanced Properties Display.....	471
Engineering Tab.....	471
HMI Configuration Tab.....	472

Diagnostics Tab .....	473
Alarms Tab .....	473
n-Position Device (P_nPos).....	474
Display Elements .....	475
Operator Tab .....	477
Maintenance Tab.....	478
Advanced Properties Display .....	479
Advanced Maintenance Tab.....	479
Engineering Tab.....	481
HMI Configuration Tab.....	484
Diagnostics Tab .....	486
Alarms Tab .....	486
Discrete 2-, 3-, 4-state Device (P_D4SD).....	487

## Chapter 7

### Built-in Instructions Family

Proportional + Integral + Derivative Enhanced (PIDE) Autotune	489
Autotune Page 1.....	490
Autotune Page 2.....	491
Autotune Page 3.....	492
Coordinated Control (CC).....	493
Display Elements .....	493
Operator Tab .....	494
Maintenance Tab.....	495
Advanced Tab.....	496
Trends Tab .....	503
Diagnostics Tab .....	505
Coordinated Control (CC) Autotune.....	506
Internal Model Control (IMC).....	509
Display Elements .....	509
Operator Tab .....	510
Maintenance Tab.....	511
Advanced Tab.....	513
Trends Tab .....	521
Diagnostics Tab .....	523
Internal Model Control (IMC) Autotune .....	524
Modular Multivariable Control (MMC).....	527
Display Elements .....	527
Operator Tab .....	528
Maintenance Tab.....	529
Advanced Tab.....	530
Trends Tab .....	538
Diagnostics Tab .....	541
Proportional + Integral + Derivative Enhanced (PIDE) .....	545
Display Elements .....	545
Operator Tab .....	547
Maintenance Tab.....	548
Advanced Tab.....	550

---

Trends Tab .....	559
Diagnostics Tab .....	561
Ramp/Soak (RMPS) .....	561
Display Elements .....	561
Operator Tab .....	562
Maintenance Tab.....	563
Advanced Tab.....	564
Trends Tab .....	565
Diagnostics Tab .....	565
Totalizer (TOT).....	566
Display Elements .....	566
Operator Tab .....	568
Maintenance Tab.....	569
Advanced Tab.....	570
Trends Tab .....	571
Diagnostics Tab .....	572

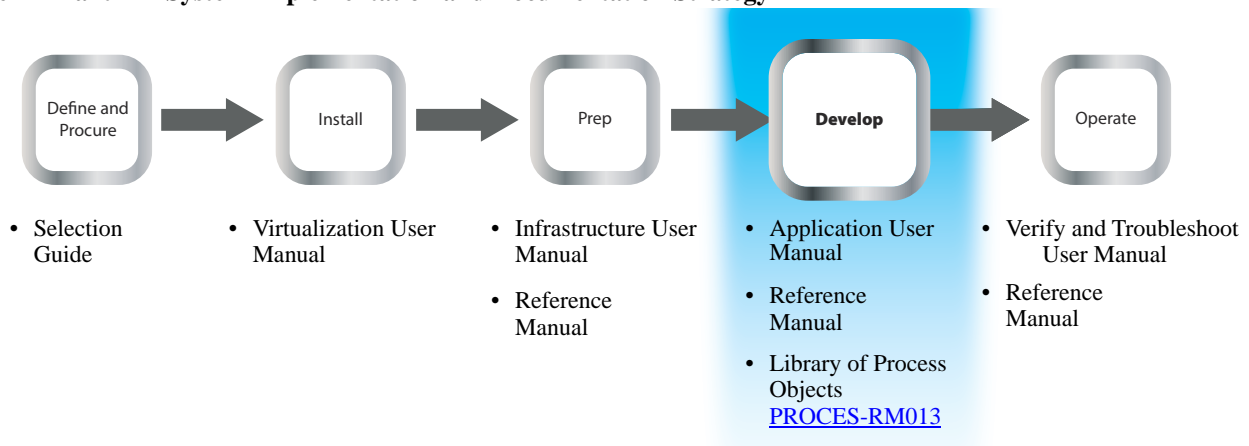
**Notes:**

This document explains the visualization files and the Human Machine Interfaces (HMI) that are contained in Add-On Instructions that comprise the volume of Rockwell Automation® Library of Process Objects. Sections are divided into classifications that are based on what criteria the Add-On Instructions control and monitor, such as motors.

This document is for the visualization files, display elements, global objects, and HMI information. The visualization files for each instruction family are PDF in the form of a Microsoft Excel spreadsheet. See [Access the Attachments on page 16](#) for how to access the attachments.

The operation of the Add-on Instructions and controller code is contained in publication [PROCES-RM013](#).

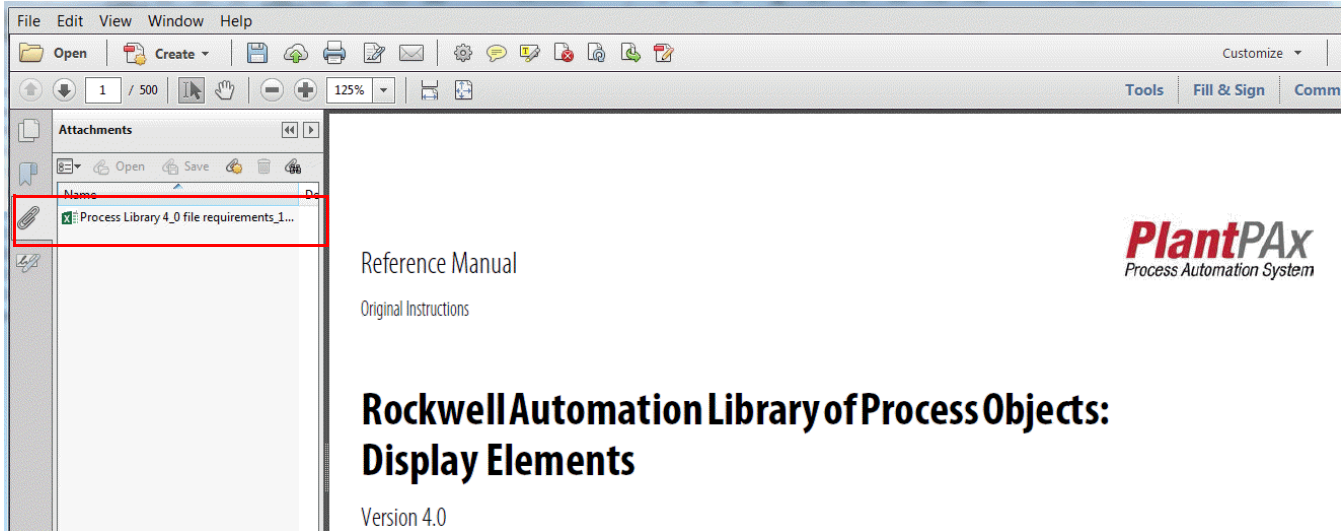
**Figure 1 - PlantPAx System Implementation and Documentation Strategy**



- **Define and Procure** – Helps you understand the elements of the PlantPAx® system to make sure that you buy the proper components.
- **Install** – Provides direction on how to install the PlantPAx system.
- **Prep** – Provides guidance on how to get started before you develop your application.
- **Develop** – Describes the actions and libraries necessary to construct your application that resides on the PlantPAx system.
- **Operate** – Provides guidance on how to verify and maintain your systems for operation of your plant.

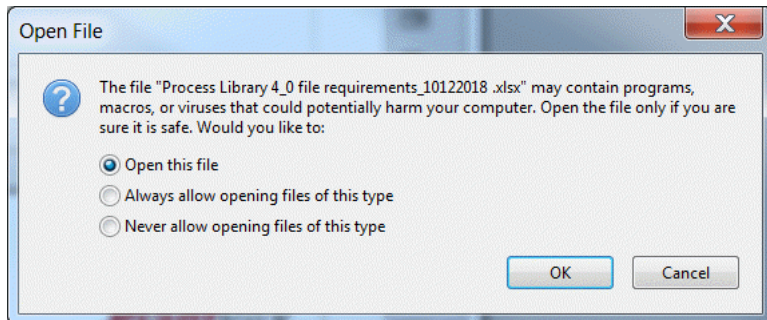
**Access the Attachments** The Microsoft Excel spreadsheets that are attached to this PDF file list the visualization files required for each Add-On Instruction.

To use a Microsoft Excel file, click the Attachments link (the paper clip) and double-click the desired file.



### Open Content

As a precaution when you open programs or files, select one of the choices and click OK.





## How to Use Attachments

The Microsoft Excel spreadsheet has five tabs: Process Library, Logix Library, BuiltIn Library, Sequencer, and LBSM. On each tab, the Add-On Instructions are at the top of the spreadsheet. The visualization files are located down the left side of the spreadsheet. An 'X' in the column indicates that visualization file is required. An 'O' in the column indicates that the visualization file is the visualization file is optional.

	Z	AA	AB	AC	AD	AE	AF	AG	AH	AI	AJ	AK	AL	AM	AN	AO
	P_Intrlk	P_LLS	P_Logic	P_Motor	P_Motor2Spd	P_MotorHO	P_MotorRev	P_nPos	P_Perm	P_PF52X	P_PF6000	P_PF753	P_PF755	P_PF7000	P_PIDE	P_Reset
1	<b>X = Required</b> <b>O = Optional</b>															
2	<b>Global Object Files</b>															
3																
4	(RA-BAS) Common Faceplate Objects.ggfx	X	X	X	X	X	X	X	X	X	X	X	X	X	X	X
5																
6	(RA-BAS) BuiltIn Faceplate Objects.ggfx														O	
7	(RA-BAS) BuiltIn Graphics Library.ggfx														O	
8																
9	(RA_BAS) Process Command Source Objects.ggfx	X		X	X		X	X		X	X	X	X	X	X	
10	(RA_BAS) Process Faceplate Common Objects.ggfx	X	X	X	X	X	X	X	X	X	X	X	X	X	X	
11	(RA-BAS) Process Alarm Objects.ggfx	X		X	X	X	X		X	X	X	X	X	X		
12	(RA-BAS) Process Diagnostic Objects.ggfx	X		X	X	X	X		X	X	X	X	X	X		
13	(RA-BAS) Process Faceplate Analog Objects.ggfx														X	
14	(RA-BAS) Process Faceplate Misc Objects.ggfx		X					X								
15	(RA-BAS) Process Faceplate Motor Objects.ggfx	X		X	X	X	X		X	X	X	X	X	X	X	X
16	(RA-BAS) Process Faceplate Valve Objects.ggfx															
17	(RA-BAS) Process Graphics Library.ggfx		X												X	X
18	(RA-BAS) Process Interlock Objects.ggfx	X		X	X	X	X	X	X	X	X	X	X	X		
19	(RA-BAS) P_AIn Graphics Library.ggfx															
20	(RA-BAS) P_D4SD Graphics Library.ggfx															
21	(RA-BAS) P_D4SD Motor Graphics Library.ggfx															

## Additional Resources

These documents contain additional information that concerns related products from Rockwell Automation.

Resource	Description
PlantPAx Distributed Control System Selection Guide, publication <a href="#">PROCES-SG001</a>	Provides basic definitions of system elements and sizing guidelines for procuring a PlantPAx system.
PlantPAx Distributed Control System Infrastructure Configuration User Manual, publication <a href="#">PROCES-UM001</a>	Describes procedures for how to configure system components that comprise a PlantPAx modern DCS.
PlantPAx Distributed Control System Application Configuration User Manual, publication <a href="#">PROCES-UM003</a>	Describes procedures to start development of your PlantPAx distributed control system.
PlantPAx Distributed Control System Reference Manual, publication <a href="#">PROCES-RM001</a>	Provides characterized recommendations for implementing your PlantPAx system.
Rockwell Automation Library of Process Objects Reference Manuals: Publication <a href="#">PROCES-RM013</a> Publication <a href="#">PROCES-RM014</a>	Provides an overview of the code objects, display elements, and faceplates that comprise the Rockwell Automation Library of Process Objects.
Rockwell Automation Library of Logix Diagnostic Objects Reference Manual, publication <a href="#">PROCES-RM003</a>	Provides information on Add-On Instructions that monitor Logix controllers to diagnose issues that include memory usage, communication, and control.
Rockwell Automation Library of Steam Table Instructions, publication <a href="#">PROCES-RM004</a>	Provides Add-On Instructions for to calculate temperature and pressure steam tables.
Redundant I/O System User Manual, publication <a href="#">1715-UM001</a>	Explains how to install and configure the 1715 Redundant I/O system.
Product Compatibility and Download Center at <a href="http://www.rockwellautomation.com/rockwellautomation/support/pcdc.page">http://www.rockwellautomation.com/rockwellautomation/support/pcdc.page</a>	Website helps you find product-related downloads including firmware, release notes, associated software, drivers, tools, and utilities.
Rockwell Automation Sample Code website at <a href="http://samplecode.rockwellautomation.com">http://samplecode.rockwellautomation.com</a>	Accesses a Rockwell Automation webpage to search for sample code.

You can view or download publications at <http://www.rockwellautomation.com/literature/>. To order paper copies of technical documentation, contact your local Allen-Bradley distributor or Rockwell Automation sales representative.

## Summary of Changes

Topic	Page
“On Interlock Trip” replaced with “On Interlock not OK” on screen captures throughout the document.	Throughout
New HMI Screen capture for P_Dose	<a href="#">235</a>
New Engineering Screen capture for IMC	<a href="#">518</a>

## Overview

This manual compiles the HMI visualization files that comprise the Rockwell Automation® Library of Process Objects from individual manuals into one reference manual. Before this software release, each object was documented in a separate manual. These objects, which are arranged by device family, provide visual components to enable interaction with instrument data.

There are three visualization files that are associated with each Add-On Instruction: Images, Global objects, and HMI faceplates. This manual features the visualization files that control various instructions for motors, valves, drives, interlocks, permissives, and additional devices that can be used with the PlantPax® system.

---

**IMPORTANT** To view spreadsheets with parameters and local tags for each Add-On Instruction, see the Rockwell Automation Library of Process Objects: Controller Code Reference Manual, publication [PROCES-RM013](#).

---

The required visualization files are included in the Process Library download from the Product Compatibility and Download Center (PCDC). The files build on one another and must be imported in the following order:

- Images
- Global objects
- Standard display files

Images are external graphic files that can be used in displays. They must be downloaded from PCDC to be used by FactoryTalk® View software.

Global object files are display elements that are created once and referenced multiple times on multiple displays in an application. When changes are made to a global object, all instances in the application are automatically updated.

Global objects serve two purposes:

- Faceplate object files contain common elements that are used to build faceplate displays.
- Graphics Library files contain device symbols that you can use to build your application displays. Click the symbol to open the corresponding faceplate display.

Standard display files, commonly called faceplates, provide a common user interface.

## Required Files

Visualization files can be downloaded from the PCDC at <http://www.rockwellautomation.com/rockwellautomation/support/pcdc.page>.

**IMPORTANT** The visualization file dependencies require Process Library content imports to occur in a specific order:

- Images
- Global Objects
- Standard Displays
- HMI Tags
- Macros

The following table describes the visualization file types.

**Table 1 - Visualization File Types**

File Type Abbreviations	FactoryTalk View SE	FactoryTalk View ME	Description
Images (.png)	All .png files in the images folder. <b>IMPORTANT:</b> FactoryTalk View application renames PNG files when they are imported with a .bmp file extension, but the files retain a .png format.		Common icons that are used in the global objects and standard displays for all Process Objects.
Global objects (.ggfx)	(RA-BAS) precedes name of the global object.	(RA-BAS-ME) precedes name of the global object.	Examples: (RA-BAS) Common Faceplate Objects (RA-BAS-ME) Common Faceplate Objects
Standard displays (.gfx)	(RA-BAS) precedes name of the display.	(RA-BAS-ME) precedes name of the display.	Examples: (RA-BAS) P_AIn-Faceplate (RA-BAS-ME) P_AIn-Faceplate

Table 1 - Visualization File Types

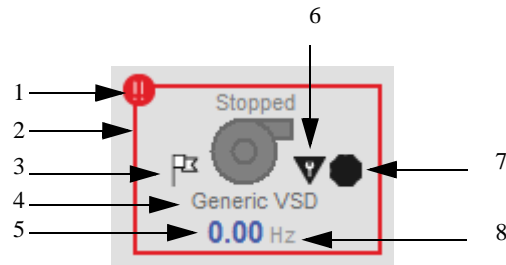
File Type Abbreviations	FactoryTalk View SE	FactoryTalk View ME	Description
HMI tags (.csv)	FTViewSE_ProcessLibrary_Tags_4_0_XX.csv where <b>XX</b> = the service release number.	FTViewME_ProcessLibrary_Tags_4_0_XX.csv where <b>XX</b> = the service release number.	HMI tags are created in a FactoryTalk View ME application to support security, tab control, and other features on Process Library faceplates. HMI tags can be imported via the comma-separated values file (.csv file type).
Macros (.mcr file)	NavToBuiltInCCFaceplate.mcr NavToBuiltInCCQuick.mcr NavToBuiltInIMCFaceplate.mcr NavToBuiltInIMCQuick.mcr NavToBuiltInMMCFaceplate.mcr NavToBuiltInMMCQuick.mcr NavToBuiltInPIDEFaceplate.mcr NavToBuiltInPIDEQuick.mcr NavToBuiltInRMPSFaceplate.mcr NavToBuiltInTotalizerFaceplate.mcr NavToChildFaceplate.mcr NavToFaceplate with line of site.mcr* NavToFaceplate.mcr NavToP_LLS_Motor.mcr NavToQuick with line of site.mcr* NavToQuick.mcr	Macros not used with FactoryTalk View ME.	In a FactoryTalk View SE application, a macro is a series of commands that are stored in a text file. In a FactoryTalk View ME application, a macro is a list of tag assignments that are stored in a text file.
	* To restrict the operation of equipment based on line of site requirements, rename the macros: "NavToFaceplate with line of site.mcr" to "NavToFaceplate.mcr" "NavToQuick with line of site.mcr" to "NavToQuick.mcr"		

## Basic Attributes and Indicators

This section shows examples of visual tools that are common for global objects in the Rockwell Automation Library of Process Objects. Visual tools are critical to the daily operation of a plant.

Common attributes of global objects typically include:

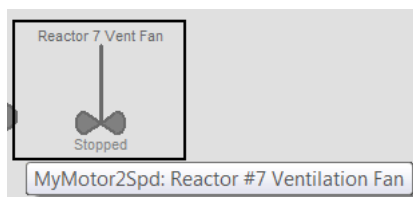
- Status/quality/threshold indicator
- Maintenance bypass indicator
- Engineering units
- Label
- Command Source indicator (only for non-analog inputs)
- Alarm border that changes color and blinks on unacknowledged alarm
- Alarm indicator symbol that changes with the severity of an alarm



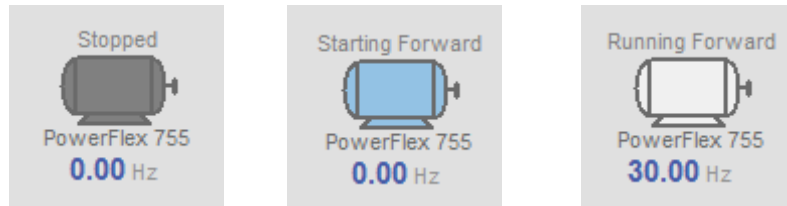
**Table 2 - Global Objects Description**

Item	Description
1	Alarm indicator
2	Alarm border
3	Command source indicator (In the example the flag indicates not in normal command source)
4	Label
5	Process variable
6	Maintenance bypass indicator
7	Not Ready Indicator
8	Engineering units

Each graphic object includes a touch field over it that opens the faceplate. In addition, there is a tooltip on the graphic symbol that displays the configured tag and description.



## State Indicators



The State Indicator text and the color change depending on the state of the drive. The indicators and colors are common across all Add-On Instructions.







**Table 3 - State Indicator Colors**

Color	State
Dark gray	Stopped
Light blue	Starting
Light blue	Jogging
Light blue	Stopping
Light blue	Horn
White	Running


















## Status/Quality Indicators

One of these symbols appears on the graphic symbol when the described condition is true.

**Table 4 - Status/Quality Indicators**





Graphic Symbol	Description
No symbol that is displayed	I/O communication and quality good, configuration valid
	Invalid configuration
	Data quality bad/failure
	Data Quality degraded: uncertain, test, simulation, substitution, or out of specification
	Device not ready to operate
	The input or device has been disabled
	Alarm Inhibit (Suppressed or Bypassed)

**Table 4 - Status/Quality Indicators**

Graphic Symbol	Description
	Device in loopback test
	At target speed
	Speed ref limited to the minimum / maximum
	Value infinite or not a number
	value is being held at last good value
	Input Controlled Variable that is clamped to minimum / maximum
	Output Controlled Variable that is clamped to minimum / maximum
	Accelerating
	Decelerating
	Value is being initialized
	Value has not changed (stuck)
	Value is being replaced
	Input matches target
	input does not match target
	Auto loop mode
	Manual loop mode
	Cascade loop mode



**Table 4 - Status/Quality Indicators**





Graphic Symbol	Description
	Motor not controllable
	Process Variable within setpoint deadband (no control action occurs)
	Raise Process Variable output that is energized
	Lower Process Variable output that is energized

**TIP** When the Invalid Configuration indicator appears, you can find what configuration setting is invalid by following the indicators. Click the graphic symbol to open the faceplate. The Invalid Configuration indicator appears next to the appropriate tab at the top of the faceplate to guide you to the configuration error. Once you navigate to the tab, the misconfiguration is flagged with this indicator.

## Threshold Indicators

These indicators show that the process variable has exceeded a threshold.





**Table 5 - Threshold Indicators**

Graphic Symbol	Description
	High-high threshold exceeded
	High threshold exceeded
	Low threshold exceeded
	Low-low threshold exceeded

## Deviation Indicators

These indicators warn of exceeding the deviation limits.

**Table 6 - Deviation Indicators**






Graphic Symbol	Description
	High-high deviation exceeded
	High deviation exceeded
	Low deviation exceeded
	Low-low deviation exceeded

## Command Source Indicators






The command source indicator displays by exception only. For example, if the device is operating normally, there is not an indicator. If the device is out of service (OoS), then the OoS indicator is displayed.

Command source indicators are not used for analog inputs.

**Table 7 - Command Source Indicators**

Graphic Symbol	Description
No Symbol	Device is in normal command source operation
	Device is out of service
	Device is not in normal command source operation
	Device is in program command source operation
	Device is in program locked command source
	Device is in maintenance command source operation


**Table 7 - Command Source Indicators**

Graphic Symbol	Description
	Device is in operator command source operation
	Device is in external command source operation
	Device is in operator locked command source operation
	Device is in override command source operation
	Device is in hand command source operation

## Maintenance Bypass Indicator

The maintenance bypass indicator appears to the right of the label to indicate that a maintenance bypass has been activated. The Maintenance bypass indicator appears when the Substitute PV function is enabled. A Maintenance-entered value supersedes the 'live' process variable.

**Table 8 - Maintenance Bypass Indicator**

Graphic Symbol	Description
	A maintenance bypass is active
No symbol displayed	No maintenance bypass is active

**TIP** When the Maintenance bypass indicator appears, you can find what condition was bypassed by following the indicators. Click the graphic symbol to open the faceplate. The Maintenance bypass indicator appears next to the appropriate tab at the top of the faceplate to guide you to the bypass. Once you navigate to the tab, the bypassed item is flagged with this indicator.

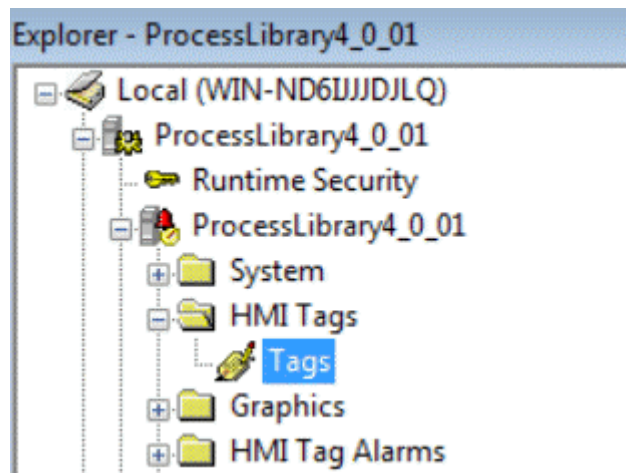
## Help Files

The help displays for the Library of Process Objects have been converted to PDF documents. The PDF documents can be displayed from the FactoryTalk View displays by clicking the Help button. The help files are downloaded as part of the Library of Process Objects and are contained in the Documents folder.

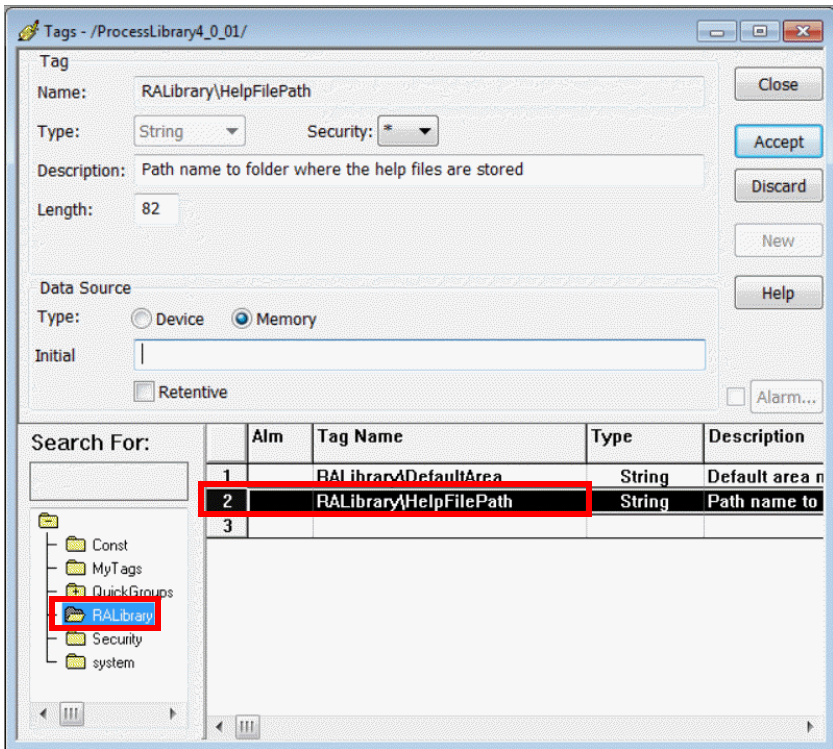
1. Copy the Help files to a folder accessible by the FactoryTalk View clients.

In this example we have copied the files to  
C:\Users\Rockwell\Desktop\HMI Help Files.

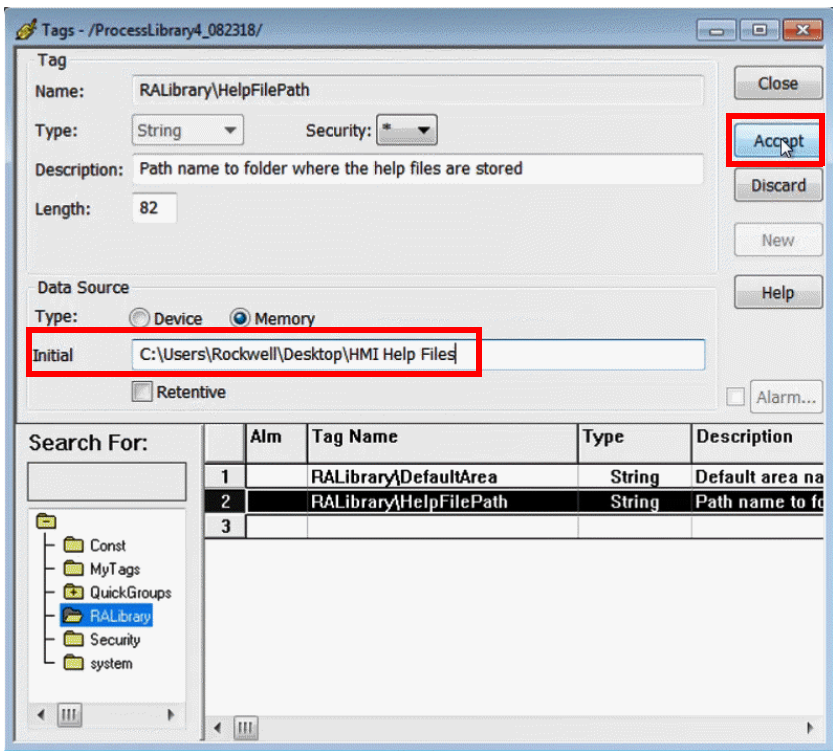
2. Open your project in FactoryTalk View Studio.
3. Open the Tags setting in the Folder Tree.



- Click the RALibrary Folder and then Click RALibrary\HelpFilePath to access the settings for the Help Files.

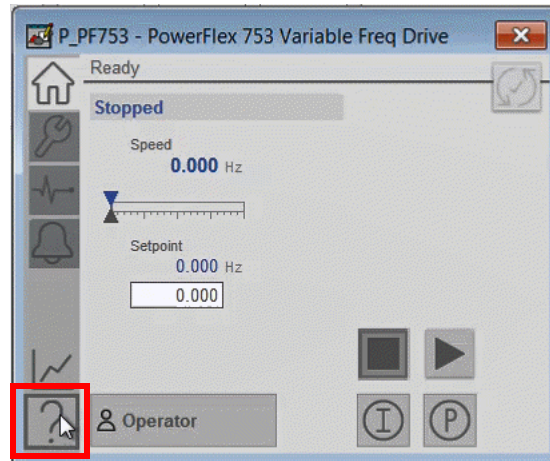


- Type the path to the Help Files into the Initial Data Source Field and click Accept.



- Close the settings display.

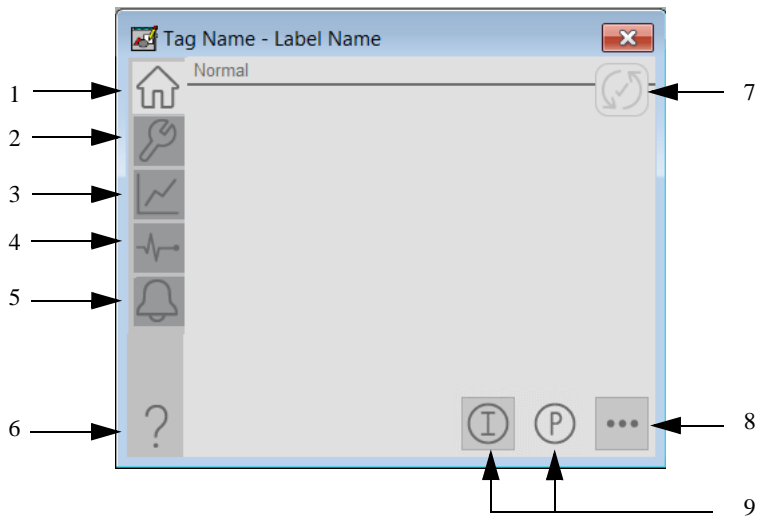
7. Restart FactoryTalk View Studio for the settings to take effect.
8. The Help Files can now be accessed using the Help button on the HMI Display.



# Basic Faceplate Attributes

Faceplates consist of tabs, and each tab consists of one or more pages. The Operator (Home) tab is displayed when the faceplate is initially opened. The faceplate provides the means for operators, maintenance personnel, engineers, and others to interact with an instruction instance, which includes a view of its status and values. Faceplates also manipulate an instruction through its commands and settings. Click the appropriate icon on the left of the faceplate to access a specific tab. This section provides an overview of the faceplate attributes that are common across the objects. More details are supplied in the individual section for each object.

## Operator (Home) Tab



**Table 9 - Operator Tab Description**

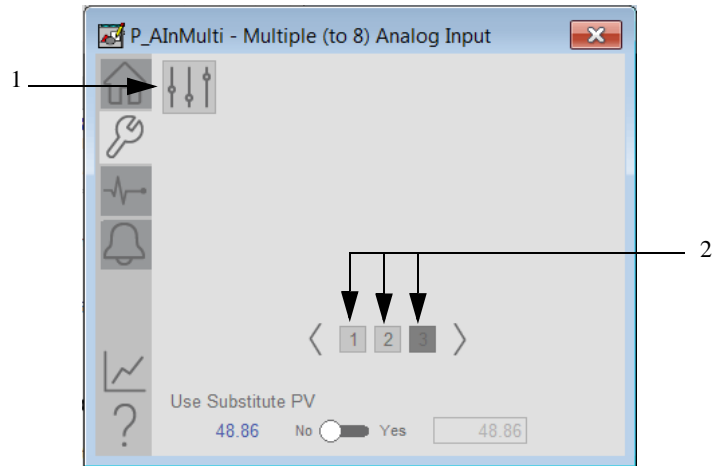
Item	Action
1	Click to open the operator tab.
2	Click to open the maintenance tab.
3	Click to open the trends tab.
4	Click to open the diagnostics tab.
5	Click to open the alarm tab.
6	Click to open the help file.



Item	Action
7	Click to reset and acknowledge all alarms.
8	<p>Click to display more information (the button is only available if Cfg_HasMoreObj is set to true.)</p> <p>This can be configured to navigate to an AOI backing tag or a UDT tag that has HMI_Type and HMI_Lib defined.</p> <p>For example, there is a motor with the tag name P_101 and there is a need to have the more information button navigate to the parent P_LLS object. A tag is created for the P_LLS object that is given the alias P101_More. When the more information button is pressed on the motor, it links to P101_More. This will open the faceplate for the LLS object.</p>
9	<p>If the object is configured to have permissive and interlock objects (for example, Cfg_HasPermObj (Fast or Slow) or Cfg_HasIntlkObj is true), the permissive and interlock indication become buttons. These buttons open the faceplates of the source objects that are used as a permissive or interlock. Often this object is a P_Perm or P_Intlk object. If the object is not configured in this way, the permissive or interlock symbols are indicators only.</p> <p>See <a href="#">Permissives with Bypass (P_Perm) on page 58</a></p> <p>See <a href="#">Interlocks with First Out and Bypass (P_Intlk) on page 45</a></p>

### Maintenance Tab

In the maintenance tab, there is a button for Advanced properties. There are also page identifiers at the bottom if there are multiple configuration pages. See the following diagram for common attributes of the maintenance tab.



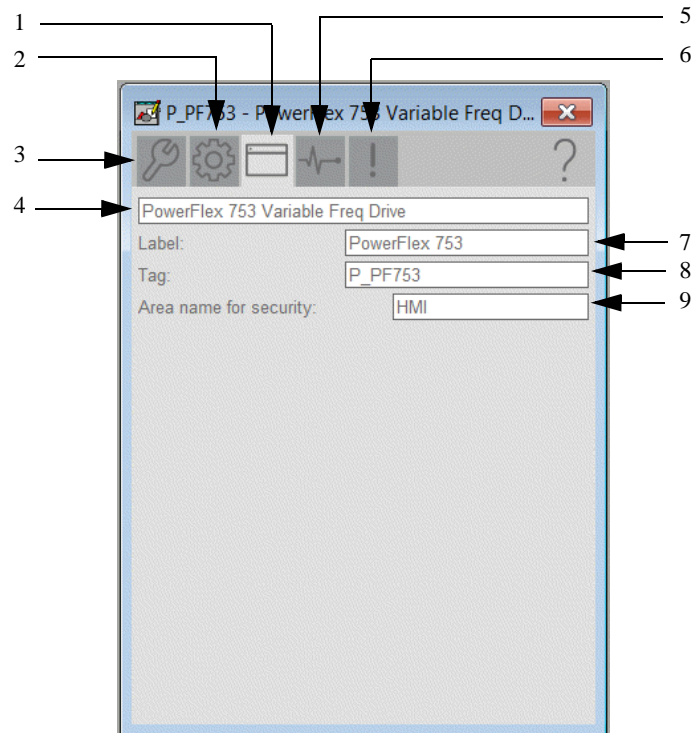
**Table 10 - Maintenance Tab Attributes**

Item	Action
1	Click to open the Advanced Properties.
2	Page identifiers. This example shows page 3.

## Advanced Properties

The advanced maintenance, engineering, HMI configuration, Diagnostics, and Faults tabs for the objects are available in the advanced properties faceplate. The advanced maintenance and engineering tabs have object-specific configurations that are detailed for each object.

The HMI configuration tab has settings that are common to the objects. See the following diagram for common attributes of the HMI configuration tab.



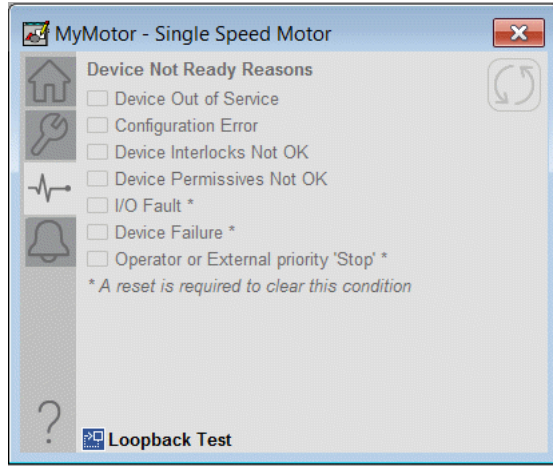
**Table 11 - Common HMI Configuration Tab Attributes**

Item	Action
1	Click to open the HMI Configuration tab.
2	Click to open the engineering tab.
3	Click to open the Advanced Maintenance tab.
4	Type the device description to show on the faceplate title bar.
5	Click to open the diagnostics tab.
6	Click to open the faults tab.
7	Type the label to show on the graphic symbol.
8	Type the tag name to show on the faceplate and Tooltip. <b>IMPORTANT:</b> Pause the mouse over this field to display a tool tip with the configured Logix tag/path.
9	Type the Area name for security.

### Diagnostics Tab

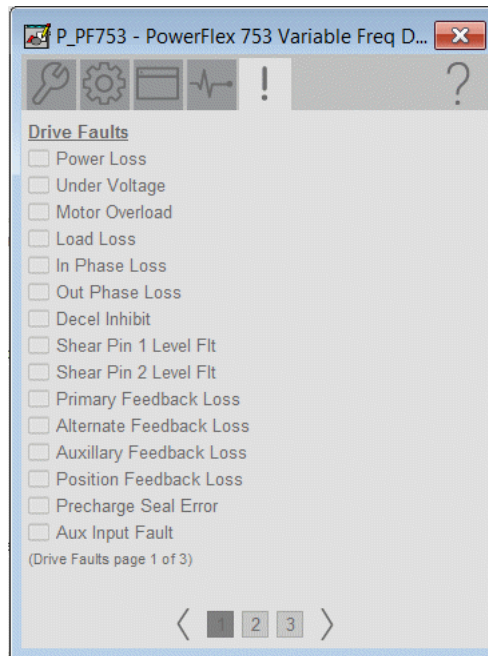
The Diagnostic tab provides indications that are helpful to diagnose or help prevent device problems. These problems can include specific reasons a device is 'Not Ready', device warnings and faults, warning and fault history, and predictive/preventive maintenance data.

The Diagnostics tab displays possible reasons for the device not being ready.



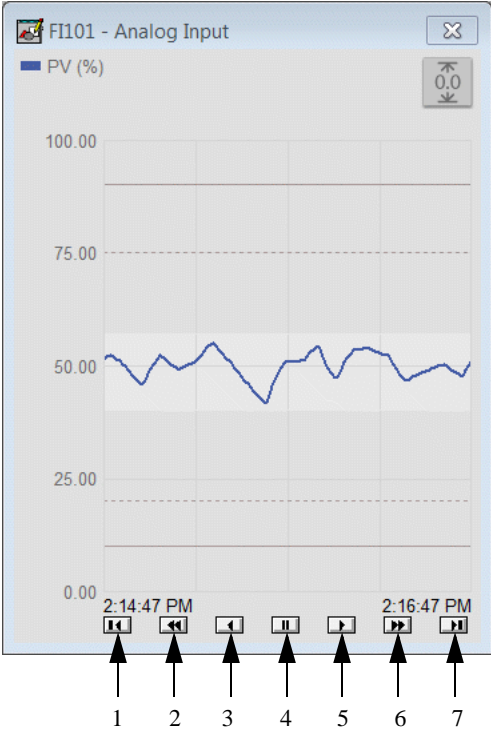
### Faults Tab

The faults tab contains specific reasons that the device is not ready.



### Trends Display

The Trends display shows trend charts of key device data over time. These faceplate trends provide a quick view of current device performance to supplement, but not replace, dedicated historical or live trend displays.



**Table 12 - Trends Tab Description**

Item	Description
1	Click to view the oldest data available.
2	Click to move trend data back 2 minutes.
3	Click to move trend data back 1 minute.
4	Click to scroll new data.
5	Click to move trend data forward 1 minute.
6	Click to move trend data forward 2 minutes.
7	Click to move to the most current trend data.

## Alarms Tab

The Alarms tab displays each configured alarm. The icon on the tab for the alarms page has an outline that changes color to show the current active alarm status. See [Common Alarm Block \(P\\_Alarm\) on page 66](#) for more information.

## Help Button

Press the help button on the faceplates to access help specific to that faceplate. The help file is in .pdf format and opens in a separate window. See the following example:

**Figure 2 - Help Example**

**Single Speed Motor Faceplate Help**

**Status Indicators**

- Invalid configuration
- Data quality bad / failure
- Data quality degraded / uncertain
- Device not ready to operate
- Alarm Inhibit (Suppressed or Disabled)
- Maintenance Bypass active
- Device in Simulation or Test

**Command Source Indicators**

- Device in Program
- Device in Maintenance
- Override
- Device not operating under normal command source
- Device in Operator
- Device in External
- Hand (Local)

**Interlocks and Permissives**

- One or more conditions not OK
- Non-Bypassed conditions OK
- All conditions OK, Bypass Active
- All conditions OK

**Commands**

- Start Motor. Available in Operator or Maintenance Command Source
- Stop Motor. Available in Operator or Maintenance Command Source

**Alarms**

- I/O Fault Alarm**  
The I/O Fault Alarm is triggered when a controller hardware or communication fault is detected.
- Interlock Trip Alarm**  
The Interlock Trip Alarm is triggered when an interlock condition causes the motor to stop.
- Fail to Start and Fail to Stop Alarm**  
These alarms trigger when the motor fails to Start or Stop within the time specified on the Maintenance Configuration Tab.

**Alarm Icons**

- Urgent
- High
- Medium
- Low
- Out of Alarm Ack Required

**Alarm Commands**

- Acknowledge Alarm. This command acknowledges an alarm that has been configured with "Ack Required".
- Acknowledge and Reset all alarms for an object. This acknowledges all active alarms and resets all alarms that have been configured with "Reset Required".

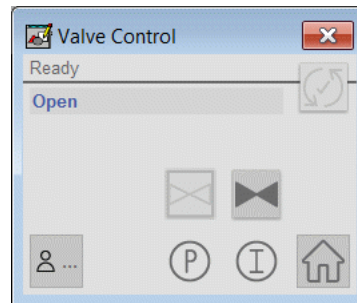
**Alarm States**

- Alarm Suppressed (disabled by controller)
- Alarm Disabled (by user)
- Alarm Shelved (logged but not annunciated)

## Quick Display Interaction

A Quick Display provides means for operators to perform simple interactions with an instruction that is instance based on a task. From the Quick Display, click the Home button to navigate to the faceplate for full access for operation, maintenance, and configuration. All other buttons function the same as on the main faceplate. The following figures show examples of quick displays.

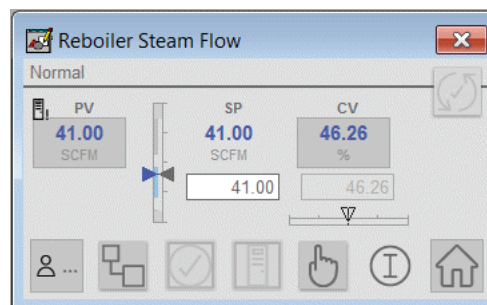
**Figure 3 - P\_ValveMP**



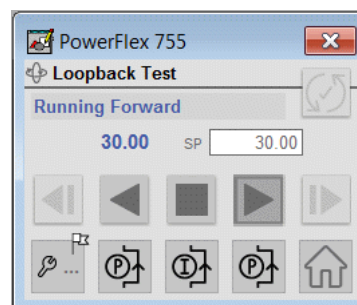
**Figure 4 - P\_Dose**



**Figure 5 - P\_PIDE**



**Figure 6 - P\_PF755**

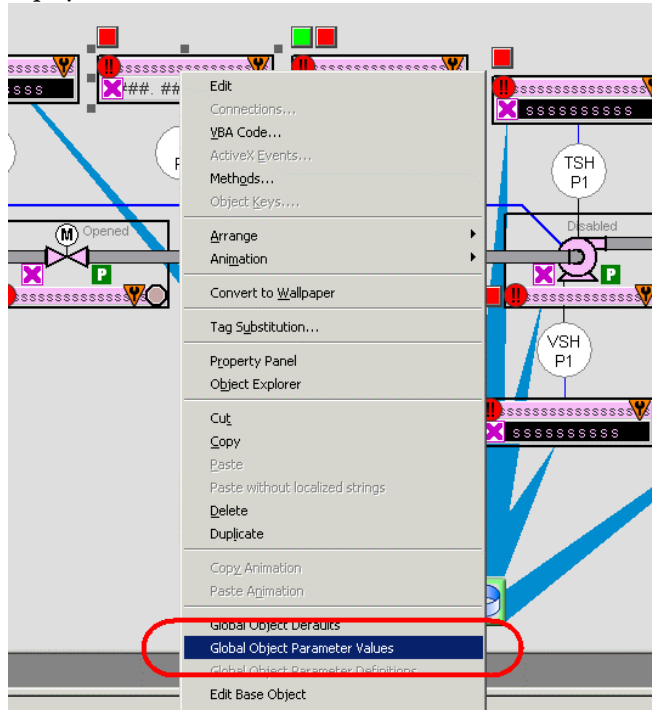


## Using a Display Element

Global objects are typically found in the global object file per instruction. For example: (RA-BAS) P\_AIn Graphics Library.ggfx.

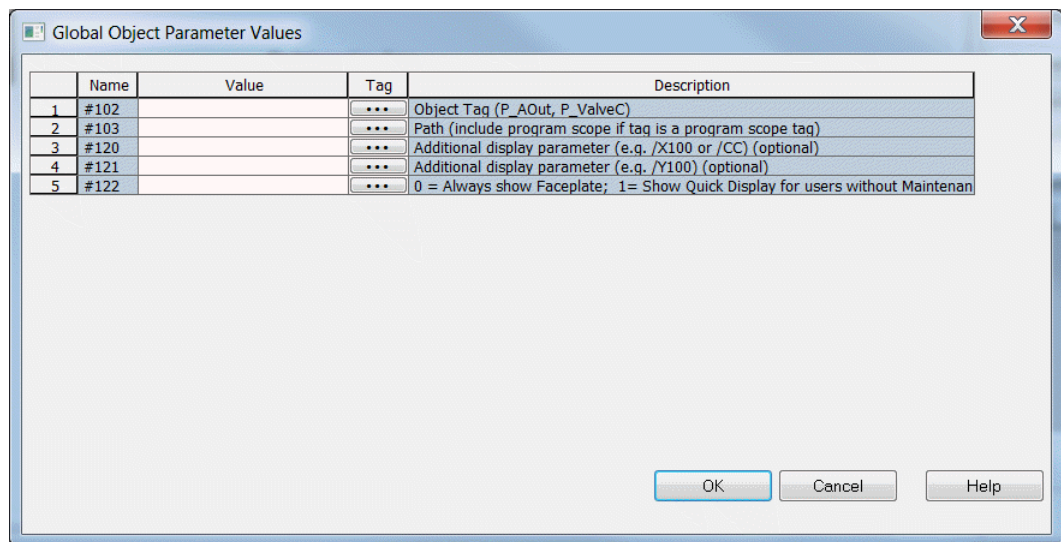
Follow these steps to use a global object.

1. Copy the global object from the global object file and paste it in the display file.



2. In the display, right-click the global object and choose Global ObjectParameter Values.

The Global Object Parameter Values dialog box appears.





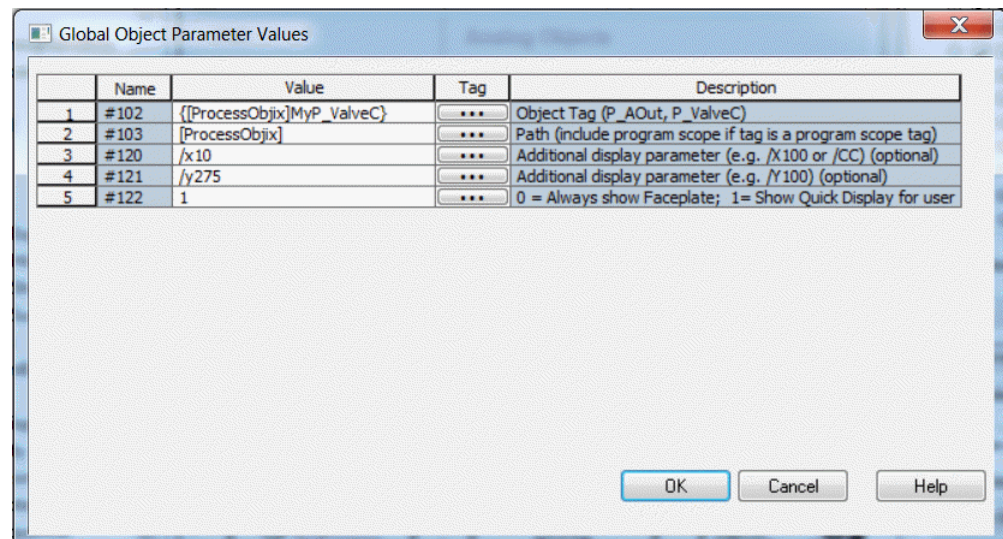
The global object parameters are as follows.

Parameter	Required	Description
#102	Y	Object tag to point to the name of the associated object Add-On Instruction in the controller.
#103	Y	Path that is used for display navigation features to other objects. Include program scope if tag is a program scope tag.
#120	N	Additional parameter to pass to the display command to open the faceplate. Typically used to define position for the faceplate.
#121	N	Additional parameter to pass to the display command to open the faceplate. To define X and Y coordinates, separate parameters so that #120 defines X and #121 defines Y. This separation lets these same parameters be used in subsequent display commands that originate from the faceplate.
#122	Y	The following are the options for the global object display: 0 = Always show faceplate 1 = Show Quick Display for users without Maintenance access (Code C) 2= Always show Quick Display

- In the Value column, type the tag or value as specified in the Description column.

**TIP** Click the ellipsis (...) to browse and select a tag. Values for items that are not required can be left blank.

**Figure 7 - Example Parameter Values Dialog Box**



- Click OK.

**Notes:**

## Cross Functional Family

The process objects in this group are often used to extend the functionality of other objects. However, they can also be used as standalone objects when necessary to implement a desired control scheme. This document is for the visualization files, display elements, global objects, and HMI information. The operation of the Add-on Instructions and controller code is contained in publication [PROCES-RM013](#).

### Condition Gate Delay (P\_Gate)

The P\_Gate (Condition Gate Delay) Add-On Instruction provides a 'gate' for a discrete signal and provides on-delay and off-delay timing for the gated signal.

P\_Gate is used within P\_DIn, all Analog inputs, and P\_PIDE for threshold and target disagree status processing.

When the gate input is true, the input is passed through to the output with on-delay and off-delay timing applied. When the gate input is false, the output is kept off (the off-delay still applies).

This document is for the visualization files, display elements, global objects, and HMI information. The operation of the Add-on Instructions and controller code is contained in publication [PROCES-RM013](#).

### Display Elements

The P\_Gate instruction is used within other device instructions to provide status and alarm timing functions. There are no dedicated display elements for this instruction. The faceplate is called from the containing instruction faceplate.

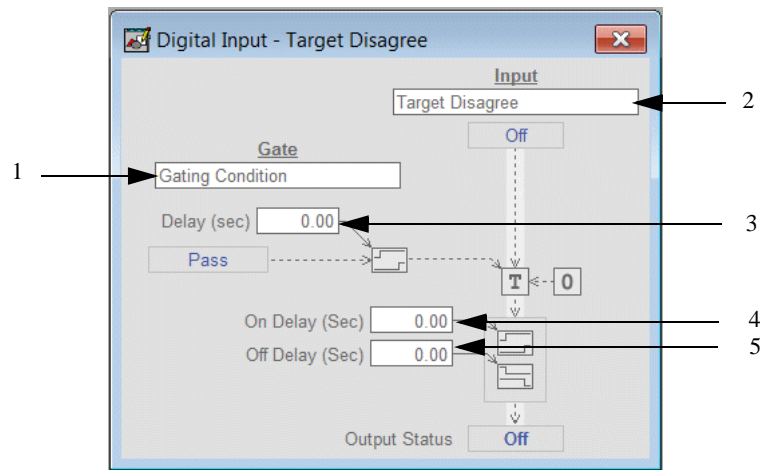
## Faceplate

From the faceplate, an operator can monitor the device status.

The Operator tab shows the following information:

- Indicators that show the current Input Value and Output Status
- Gate Input status indicator

The following figure shows the P\_Gate faceplate.



**Table 13 - Operator Tab Description**

Item	Description
1	Type the text for the gate condition.
2	Type the text for the input condition. This text appears on the Maintenance tab of the faceplate from which the P_Gate faceplate is opened.
3	Type the amount of time (in seconds) the gate input must be turned on for status outputs to be enabled.
4	Type the minimum time (in seconds) the input must be true to set the status. On-delay times are typically used to avoid an unnecessary status indication or alarm when a value briefly overshoots its threshold.
5	Type the amount of time (in seconds) the input must be clear in the status. Off delay times are typically used to reduce chattering status indicators or alarms.

# Interlocks with First Out and Bypass (P\_Intlk)


The P\_Intlk (Interlocks with First Out and Bypass) Add-On Instruction is used to collect (sum up) the interlock conditions that stop or de-energize a running or energized piece of equipment. This Add-On Instruction can also help prevent it from starting or being energized. Interlocks are always evaluated to de-energize equipment. For permissive conditions that must be made to start the equipment, but are ignored once the equipment is running, use the Permissives (P\_Perm) Add-On Instruction.

This document is for the visualization files, display elements, global objects, and HMI information. The operation of the Add-on Instructions and controller code is contained in publication [PROCES-RM013](#).

## Display Elements

A display element (global object) is created once and can be referenced multiple times on multiple displays in an application. When changes are made to the original (base) object, the instantiated copies (reference objects) are automatically updated. Use of global objects, with tag structures in the ControlLogix® system, aid consistency and save engineering time.

Table 14 - P\_Intlk Display Element Description

Display Element Name	Display Element	Description
GO_P_Intlk		Standard Interlock Global Object.

Graphic symbols are provided for use on end-user process graphic displays. Interlock graphic symbols have the following common attributes.







Table 15 - P\_Intlk Graphic Symbol Description

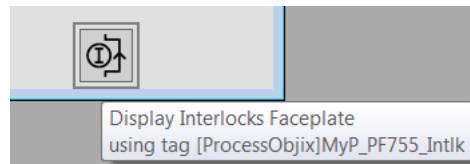
Item	Description
1	Status Indicator
2	Bypass Indicator

The Interlock graphic symbol displays the current summary state of the interlocks and whether the interlocks are bypassed.

**Table 16 - Interlock States**

Item	Description
	Not ready to run or energize. One or more interlock conditions are not OK
	Ready to run or energize. One or more conditions that can be bypassed are not OK, but these conditions are bypassed. All conditions that cannot be bypassed are OK.
	Ready to run or energize. All interlock conditions are OK.
	Ready to run or energize, and all interlock conditions are OK, conditions that can be bypassed are being bypassed and the equipment is not shut down.

The overall graphic symbol includes a touch field that opens the faceplate. In the SE version of the library, pause the pointing device over the graphic symbol to display a tooltip that describes the function of the symbol.



# Operator Tab

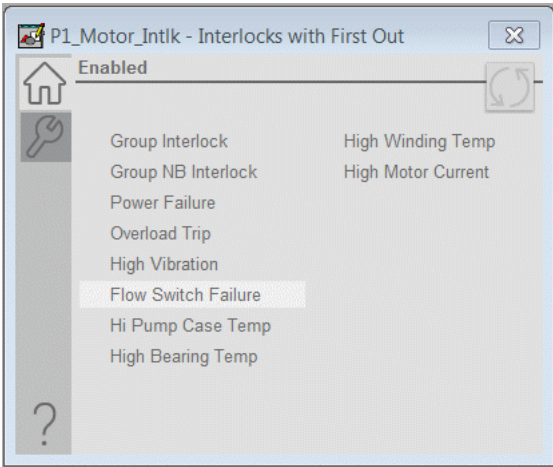
The Faceplate initially opens to the Operator (Home) Tab. From here, an operator can monitor the device status.

The Operator tab shows the following information:

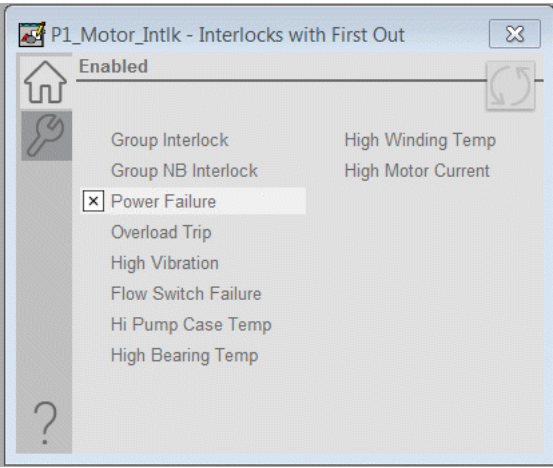
- Interlock bypass status indicator (Enabled, Bypassed)
- Each configured interlock along with the current state of the interlock

If navigation is enabled, click a condition to open the faceplate of the object that is associated with the condition.

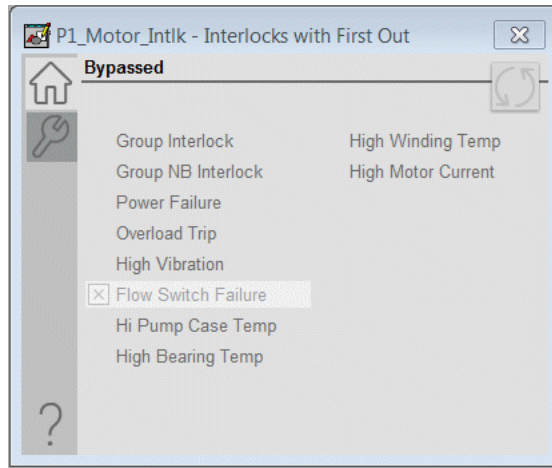
The following figure shows the Operator tab in a non-bypassed condition with no faults.



The following figure shows the Operator tab in a non-bypassed condition with a failure.



The following figure shows the Operator tab with a failure that is in a bypassed condition.





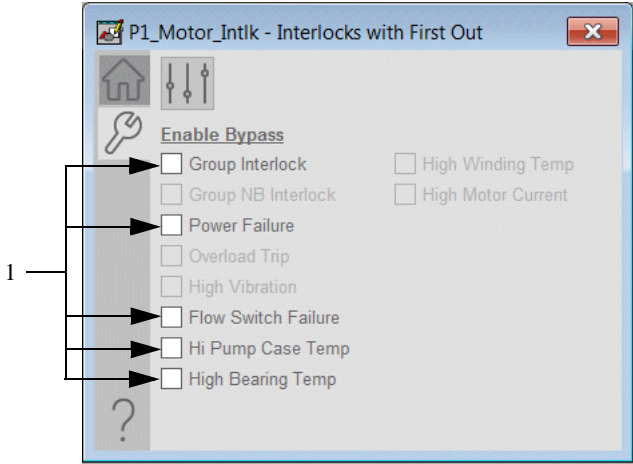
## Maintenance Tab

The maintenance tab is used to enable bypass of the interlocks that can be bypassed.

---

**IMPORTANT** Only interlocks with white checkboxes can be individually bypassed. These interlocks are configured using the 'Can Bypass' column on the engineering tab.

---



The following table lists the functions on the Maintenance tab.

**Table 17 - Maintenance Tab Descriptions**

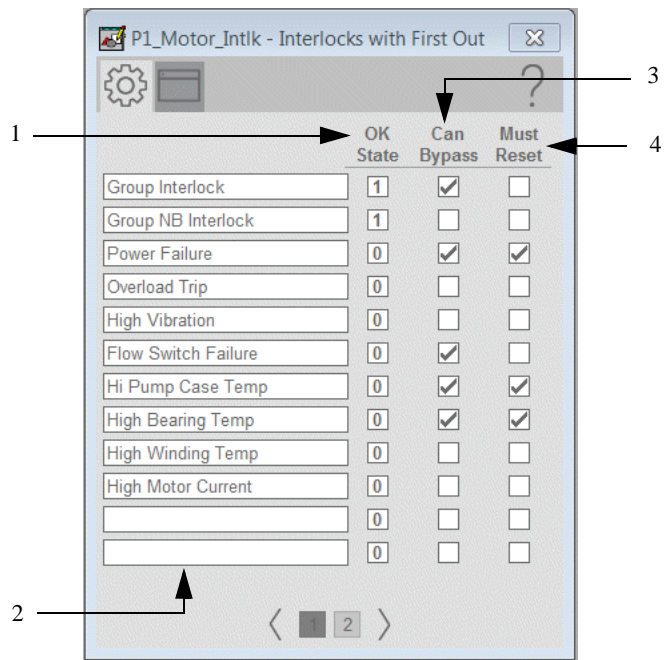
Item	Description
1	Click an interlock condition that can be bypassed, one that has a white checkbox, to enable bypass of that individual interlock. See <a href="#">HMI Configuration Tab on page 51</a> for information on how to make interlock conditions active.

## Advanced Properties Display

Click the Advanced Properties button to display the engineering and HMI configuration tabs. The Advanced Properties Display provides access to device configuration parameters and ranges, and options for device and I/O setup. The engineering tab and the HMI configuration tab can be reached from the Advanced Properties Display. This tab is used for initial system commissioning or later system changes.

### Engineering Tab

Up to 16 interlock inputs can be configured.



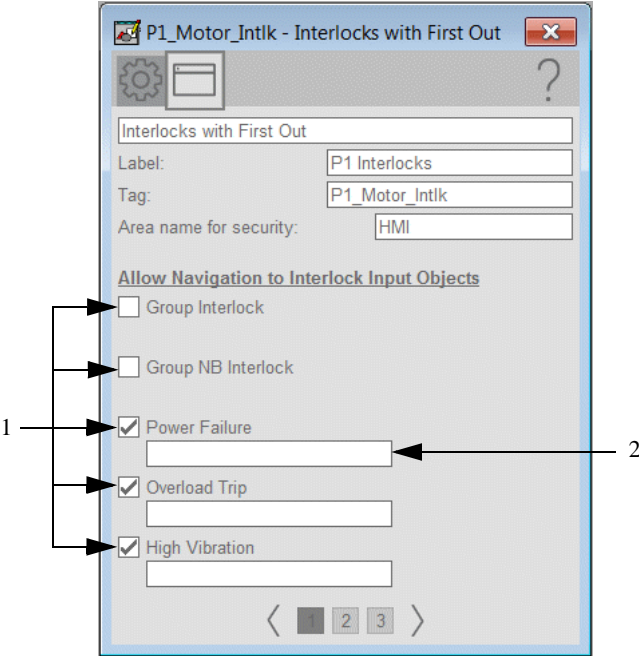
The following table lists the functions of the engineering tab.

**Table 18 - Engineering Tab Description**

Item	Description
1	Selects the state of the corresponding interlock that is the OK to Run state.
2	Type the text description of each interlock condition used. Only the interlocks with text entered appear on the Operator tab of the faceplate.
3	Check to indicate that the corresponding interlock can be bypassed.
4	Check to indicate that the corresponding interlock is latched and must be reset.

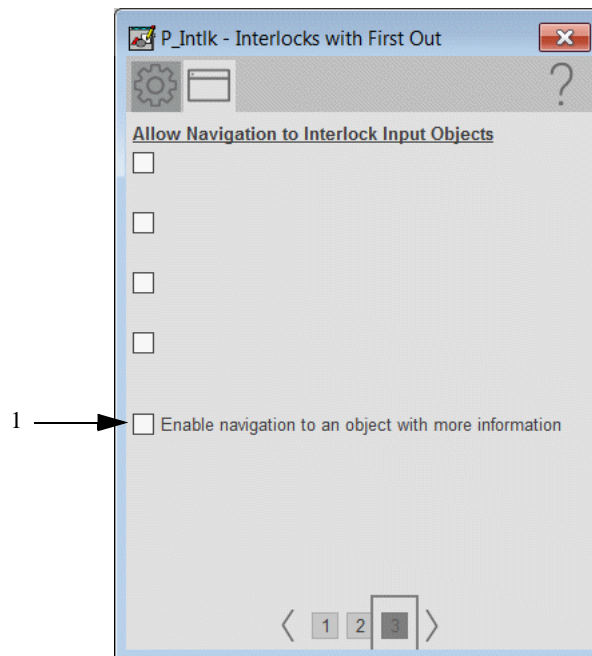
*HMI Configuration Tab*

Configure the description, label, tag, and security area for the device. See [Basic Faceplate Attributes on page 32](#) for the description of the common attributes. Navigation for the 16 interlock inputs is configured across each of the HMI configuration pages. On the third page there is an option to enable navigation to an object with more information.



**Table 19 - HMI Configuration Tab Page 1 Description**

Item	Description
1	Check to enable navigation for the corresponding interlock input object.
2	Type the name of the tag to navigate to when the interlock description on the Operator tab is clicked.



**Table 20 - HMI Configuration Tab Page3 Description**

Item	Description
1	<p>Check to enable navigation to an object with more information (Cfg_HasMoreObj is set to true.)</p> <p>This can be configured to navigate to an AOI backing tag or a UDT tag that has HMI_Type and HMI_Lib defined.</p> <p>For example, there is a motor with the tag name P_101 and there is a need to have the more information button navigate to the parent P_LLS object. A tag is created for the P_LLS object that is given the alias P101_More. When the more information button is pressed on the motor, it links to P101_More. This will open the faceplate for the LLS object.</p>

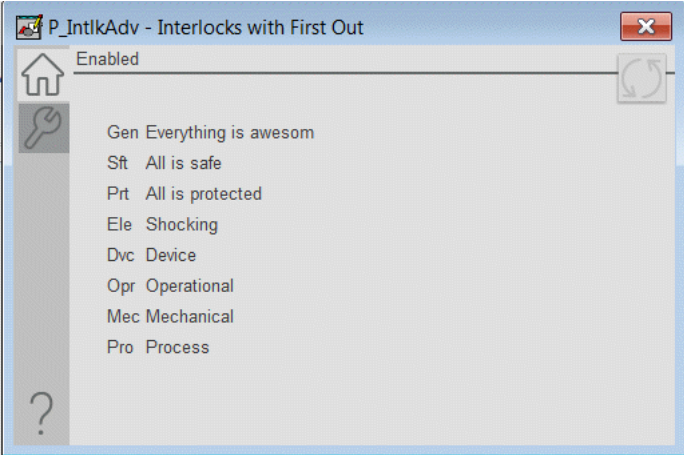
# Interlocks with First Out and Bypass - Advanced (P\_IntlkAdv)

The P\_IntlkAdv (Interlocks with First Out and Bypass - Advanced) Add-On Instruction has many of the same properties and the P\_Intlk Add-On Instruction.

The first page of the HMI Configuration Tab is changed to define the types of interlocks that are available. The fourth page has an option to enable navigation to an object with more information. The Engineering tab contains an additional field to provide the type of interlock for each condition. See [Interlocks with First Out and Bypass \(P\\_Intlk\) on page 45](#) for additional information that is related to this Add-On Instruction.

## Operator Tab

The Operator (Home) Tab shows the interlock types that are defined on the Engineering Tab.



## Maintenance Tab

The maintenance tab is used to enable bypass of the interlocks that can be bypassed.

---

**IMPORTANT** Only interlocks with white checkboxes can be individually bypassed. These interlocks are configured using the 'Can Bypass' column on the engineering tab.

---



# HMI Configuration Tab

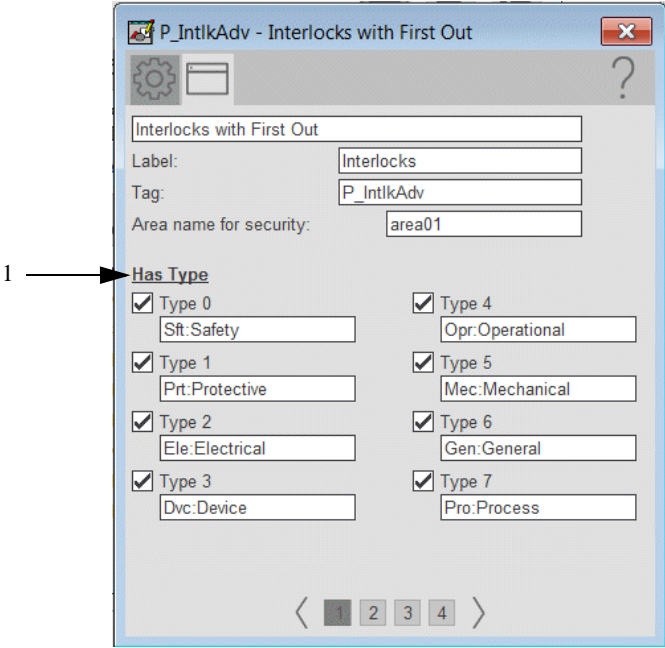
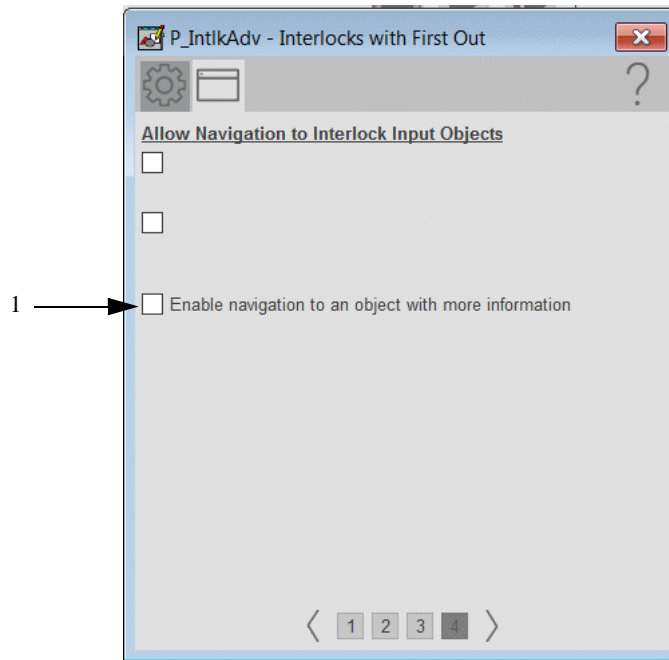


Table 21 - HMI Configuration Tab Page 1 Description

Item	Description
1	Check to enable the interlock type that can be defined in the Engineering tab. There are eight types that are configurable. The first three letters define the short name type followed by ':' and then the full type description.



**Table 22 - HMI Configuration Tab Page 4 Description**

Item	Description
1	<p>Check to enable navigation to an object with more information (Cfg_HasMoreObj is set to true.)</p> <p>This can be configured to navigate to an AOI backing tag or a UDT tag that has HMI_Type and HMI_Lib defined.</p> <p>For example, there is a motor with the tag name P_101 and there is a need to have the more information button navigate to the parent P_LLS object. A tag is created for the P_LLS object that is given the alias P101_More. When the more information button is pressed on the motor, it links to P101_More. This will open the faceplate for the LLS object.</p>



# Engineering Tab

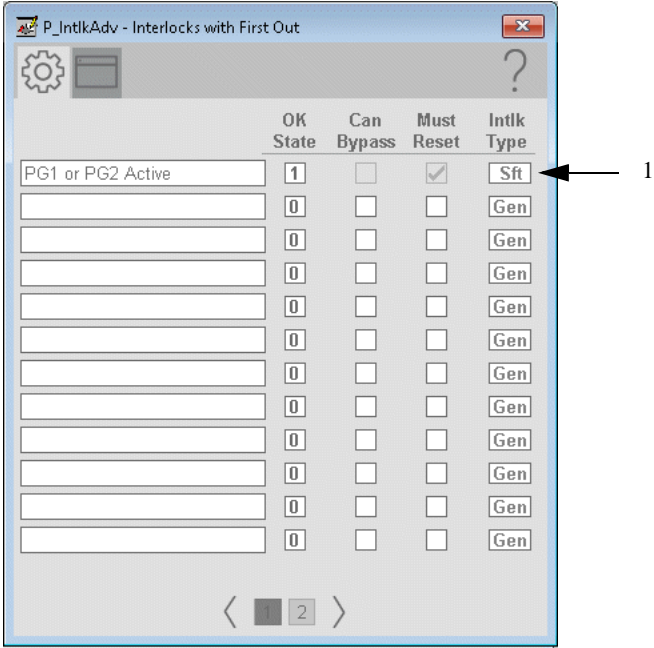


Table 23 - Engineering Tab Page 1 Description

Item	Description
1	<p>Click to define the interlock type. The display opens to select an available interlock type that was defined in the HMI Configuration.</p>

## Permissives with Bypass (P\_Perm)


The P\_Perm (Permissives with bypass) Add-On Instruction is used to collect (sum up) the permissive conditions that allow a piece of equipment to start (run, energize, open, and so forth). Permissive conditions generally must be true to start the equipment. Once the equipment is running, permissives are ignored. Use the P\_Intlk (Interlocks) Add-On Instruction to collect conditions that stop equipment that is running and help prevent it from starting.

This document is for the visualization files, display elements, global objects, and HMI information. The operation of the Add-on Instructions and controller code is contained in publication [PROCES-RM013](#).

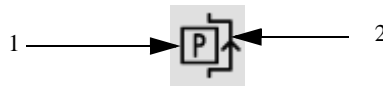
### Display Elements

A display element (global object) is created once and can be referenced multiple times on multiple displays in an application. When changes are made to the original (base) object, the instantiated copies (reference objects) are automatically updated. Use of global objects with tag structures in the ControlLogix system, aid consistency and save engineering time.

**Table 24 - P\_Perm Display Element Description**

Display Element Name	Display Element	Description
GO_P_Perm		Standard Permissive Global Object.

Graphic symbols are provided for use on end-user process graphic displays. Permissives graphic symbols have the following common attributes.







**Table 25 - P\_Perm Graphic Symbol Description**

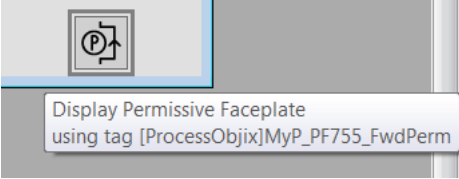
Item	Description
1	Status Indicator
2	Bypass Indicator

The Permissives graphic symbol displays the current summary state of the permissives and whether permissives are bypassed.

Table 26 - Permissive States

Item	Description
	Not ready to run or energize. One or more interlock conditions are not OK
	Ready to run or energize. One or more conditions that can be bypassed are not OK, but these conditions are bypassed. All conditions that cannot be bypassed are OK.
	Ready to run or energize. All interlock conditions are OK.
	Ready to run or energize, and all interlock conditions are OK, conditions that can be bypassed are being bypassed and the equipment is not shut down.

The overall graphic symbol includes a touch field over it that opens the faceplate. In addition, pause the mouse over the graphic symbol to display a tooltip that describes the function of the symbol.



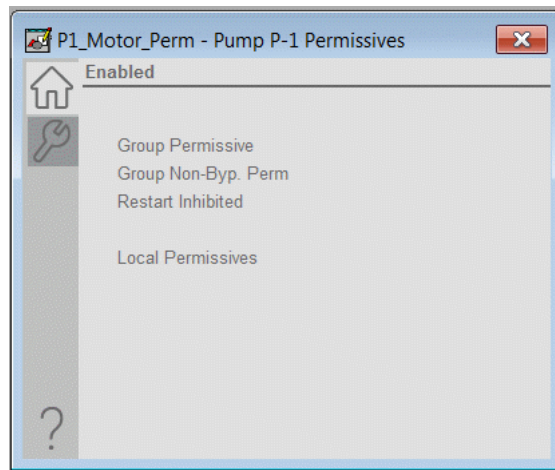
## Operator Tab

The Faceplate initially opens to the Operator (Home) tab. From here, an operator can monitor the device status.

The Operator tab shows the following information:

- Permissive bypass status indicator (Enabled, Bypassed)
- Each configured permissive along with the current state of the permissive

If navigation is enabled, click the condition to open the faceplate of the object that is associated with the condition.



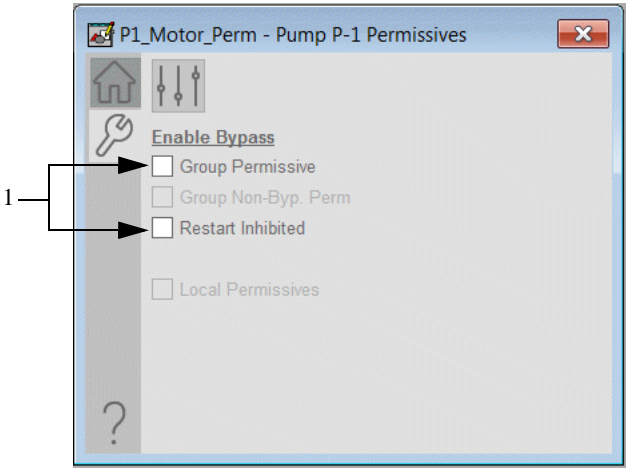
## Maintenance Tab

Maintenance personnel use the information and controls on the Maintenance tab to adjust device parameters. They also troubleshoot and temporarily work around device problems, and disable the device for routine maintenance.

---

**IMPORTANT** Only interlocks with white checkboxes can be individually bypassed. These interlocks are configured by using the 'Can Bypass' column on the engineering tab.

---



The following table lists the functions on the Maintenance tab.

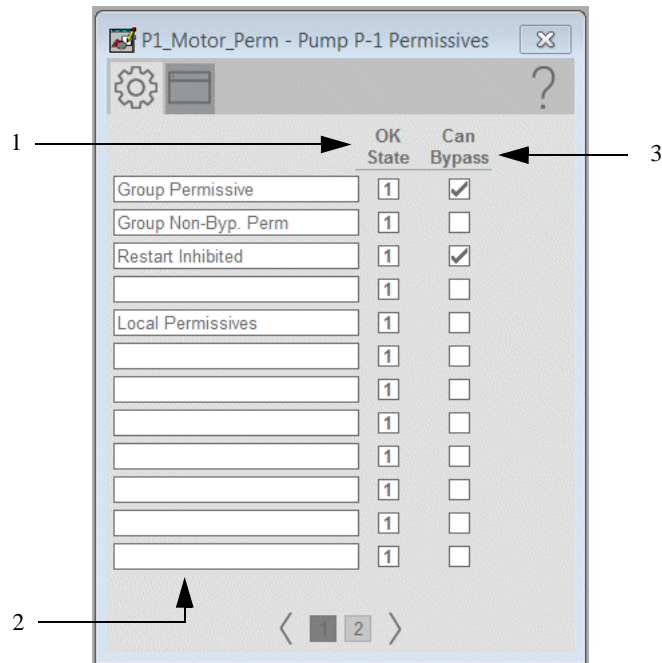
**Table 27 - Maintenance Tab Description**

Item	Description
1	Click an active permissive, one that has a white checkbox, to enable bypass of that individual permissive. See <a href="#">HMI Configuration Tab on page 63</a> for information on how to make permissive conditions active.

## Advanced Properties Display

Click the Advanced Properties button to display the engineering and HMI configuration tabs. The Advanced Properties Display provides access to device configuration parameters and ranges, and options for device and I/O setup. The engineering tab and the HMI configuration tab can be reached from the Advanced Properties Display. This tab is used for initial system commissioning or later system changes.

### Engineering Tab



The following table lists the functions of the engineering tab.

**Table 28 - Engineering Tab Description**

Item	Description
1	Selects the state of the corresponding permissive that is the OK to Run state.
2	Type the text description of each permissive condition used. Only the permissives with text entered appear on the Operator tab of the faceplate.
3	Check to indicate that the corresponding permissive can be bypassed.

HMI Configuration Tab

Configure the description, label, tag, and security area for the device. See Basic Faceplate Attributes on page 32 for the description of the common attributes. Navigation for the 16 permissive inputs is configured across each of the HMI configuration tabs. On page 3 there is an option to enable navigation to an object with more information.

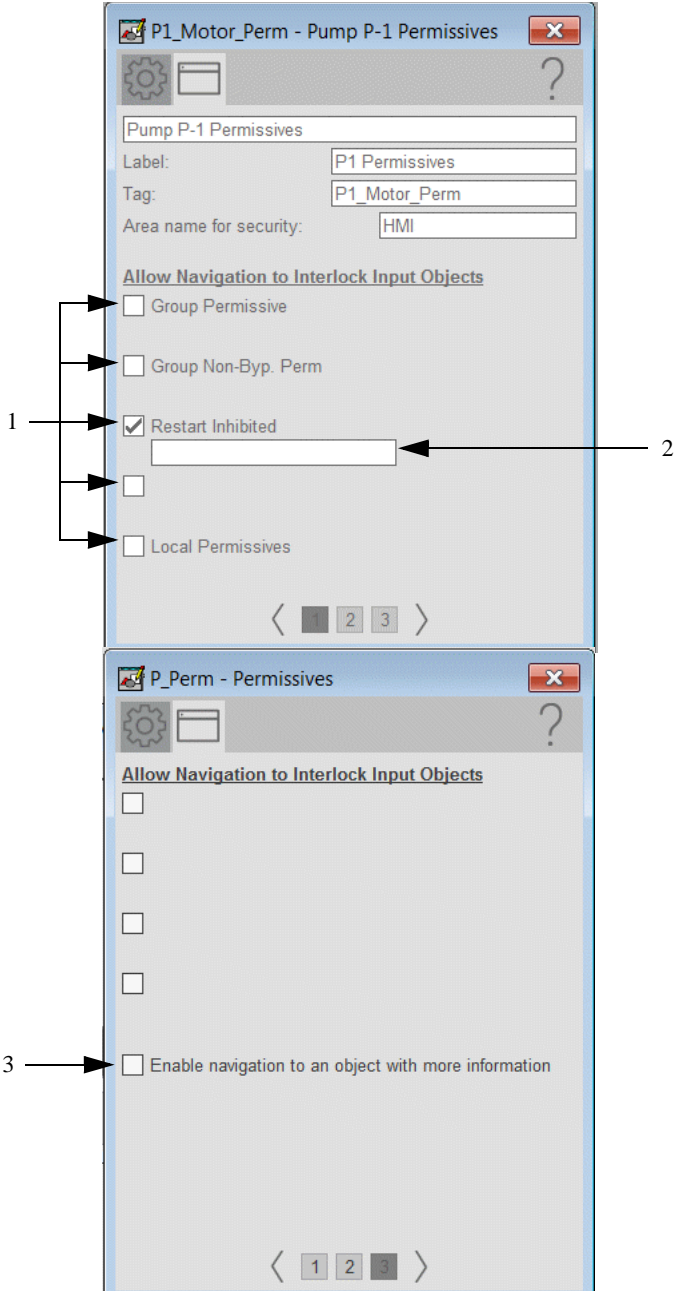


Table 29 - HMI Configuration Tab Description

Item	Description
1	Check to enable navigation for the corresponding permissive input object.
2	Type the name of the tag to navigate to when the permissive description on the Operator tab is clicked.

<b>Item</b>	<b>Description</b>
3	Check to enable navigation to an object with more information.



## Central Reset (P\_Reset)



The P\_Reset (Central Reset) Add-On Instruction provides a central point to reset equipment faults. Latched alarms can be reset for a control strategy.

This document is for the visualization files, display elements, global objects, and HMI information. The operation of the Add-on Instructions and controller code is contained in publication [PROCES-RM013](#).

### Graphic Symbols

The following table describes the graphic symbols of the P\_Reset.

**Table 30 - Graphic Symbols Description**

Button	Description
	The same as the reset buttons used in other Process Library Faceplates and screens and is for use on end-user process graphic displays.
	The reset button is inactive.

## Common Alarm Block (P\_Alarm)





The P\_Alarm (Common Alarm Block) Add-On Instruction is used to provide notification to operators of abnormal conditions or events. This instruction handles alarm acknowledgment, alarm reset, alarm shelving/disabling, and alarm suppression (for FactoryTalk® Alarms and Events). This instruction excludes display elements.

This document is for the visualization files, display elements, global objects, and HMI information. The operation of the Add-on Instructions and controller code is contained in publication [PROCES-RM013](#).

### *Alarm Indicators*

One of these symbols appears on the left of the label to indicate the described alarm condition. The alarm border blinks if acknowledgment of an alarm condition is required. Once the alarm is acknowledged, the alarm border remains the color that corresponds to the severity of the alarm and the alarm symbol is still present.

**Table 31 - Alarm Indicators Description**

Symbol	Border Color	Description
	Red	Urgent-severity alarm
	Orange	High-severity alarm
	Yellow	Medium-severity alarm
	Magenta	Low-severity alarm
	White	Return to normal (no alarm condition), but a previous alarm has not been acknowledged

Alarm indicators appear on the Home tab when the corresponding alarm occurs. The alarm indicator appears in the top banner along with the matching color border. The colored border blinks when an alarm is identified. The Alarm tab also has a border with the alarm color when an alarm is identified. The following diagram provides an example of a PV High alarm on an analog input device.

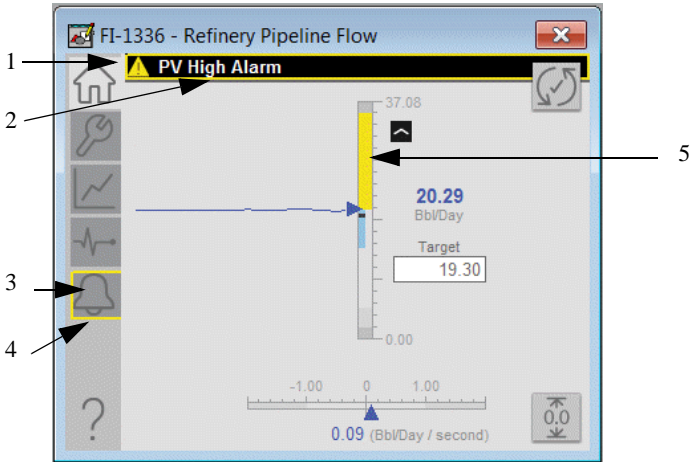


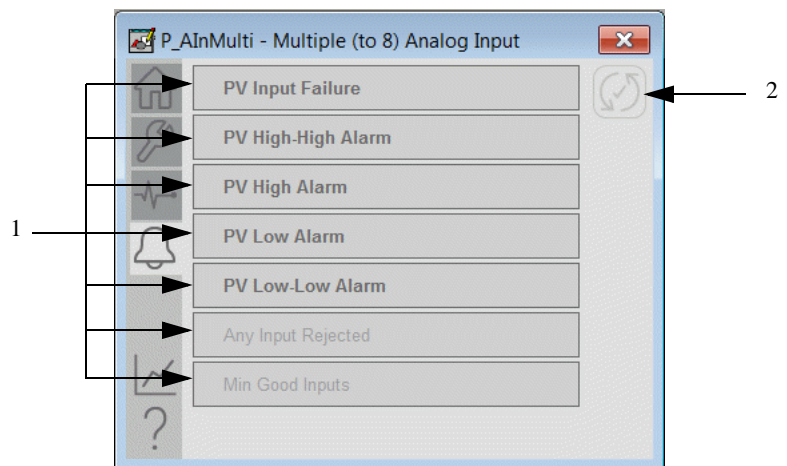
Table 32 - Alarm Identifiers Description

Item	Description
1	PV High Alarm Identified
2	Alarm Border Colored
3	Alarm Tab
4	Alarm Tab Border Colored
5	High limit on display has changed to the alarm color to show that the threshold limit has been exceeded

### Alarm Tab

The Alarms tab displays each configured alarm for the P\_ instruction. The alarm border blinks if acknowledgment of an alarm condition is required. Once the alarm is acknowledged, the alarm border remains the color that corresponds to the severity of the alarm and the alarm symbol is still present.

When the Reset and Acknowledge All Alarms button is enabled, the border the alarm name blinks. This blinking indicates that the alarm requires acknowledgment or reset. The Alarm Acknowledge button is enabled if the alarm requires acknowledgment.

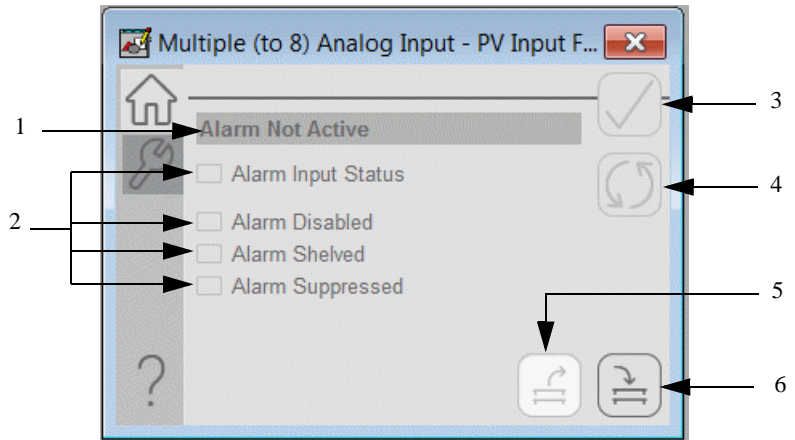


**Table 33 - Alarm Tab Description**

Item	Description
1	Alarm Description
2	Click to reset and acknowledge all alarms.

### Alarm Operator Tab

Click the alarm name to open the operator tab for that alarm.

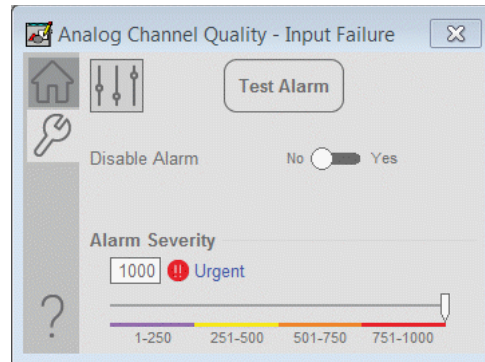


**Table 34 - Alarm Operator Tab Description**

Item	Description
1	Alarm status
2	Individual status information indicators
3	Acknowledge Alarm. This command acknowledges an alarm that has been configured with "Ack Required".
4	Reset Alarm
5	Unshelve alarm
6	Shelve alarm

### Alarm Maintenance Tab

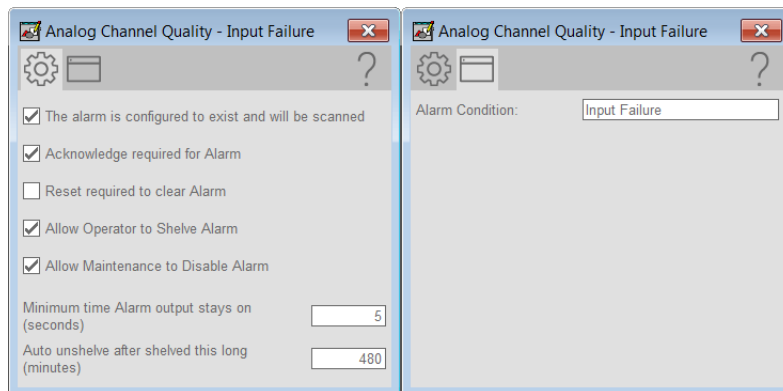
Click the alarm box to open the maintenance tab. From this tab, you can test the alarm, disable the alarm, and set the severity level of the alarm.



### Alarms Advanced Settings

Click the advanced properties button for more options.

The advanced properties include both an engineering tab and an HMI configuration tab. The HMI configuration tab is used to configure the name of the alarm. The engineering tab sets the parameters for the alarm.



## Command Source (P\_CmdSrc)









The P\_CmdSrc (Command Source) Add-On Instruction is used to provide selection of the command source (owner) of an instruction or control strategy. This instruction excludes display elements.

This document is for the visualization files, display elements, global objects, and HMI information. The operation of the Add-on Instructions and controller code is contained in publication [PROCES-RM013](#).

The command source indicator displays by exception only. For example, if the device is operating normally, there is not an indicator. If the device is out of service (OoS), then the OoS indicator is displayed.

Command source indicators are not used for analog inputs.

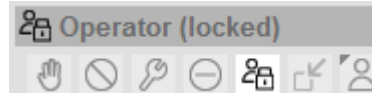
**Table 35 - Command Source Indicators**

Graphic Symbol	Description
No Symbol	Device is in normal command source operation
	Device is out of service
	Device is not in normal command source operation
	Device is in program command source operation
	Device is in maintenance command source operation
	Device is in operator command source operation
	Device is in override command source operation
	Device is in local command source operation
	Device is in external command source operation

## Command Source Totem Pole

The Command Source Totem Pole shows the sources that have been requested. These sources have a white background color. The leftmost source that is highlighted is the active command source.




In the example that follows, the current command source is Operator Locked. When Operator Locked is released, the default command source is Operator. The small black triangle, in the upper left corner of the operator indicator indicates the normal command source.



## Operator Buttons

The Operator Lock buttons on device faceplates are used to lock and unlock Operator command source. The buttons also show the current command source status.

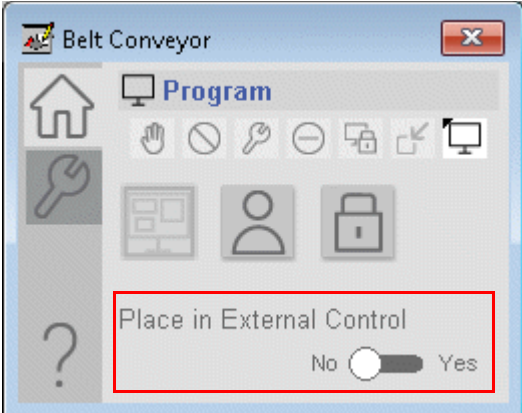
**Table 36 - Operator Buttons Description**

Graphic Symbol	Description
	Click to request Operator command source.
	Click to lock in Operator command source. The program cannot take control.
	Click to request Program command source.



*External Control*




There is a slider on the operator page that allows the operator to place the device in External Control.



## Maintenance Buttons

The maintenance buttons on device faceplates are used to request and release Maintenance command source.

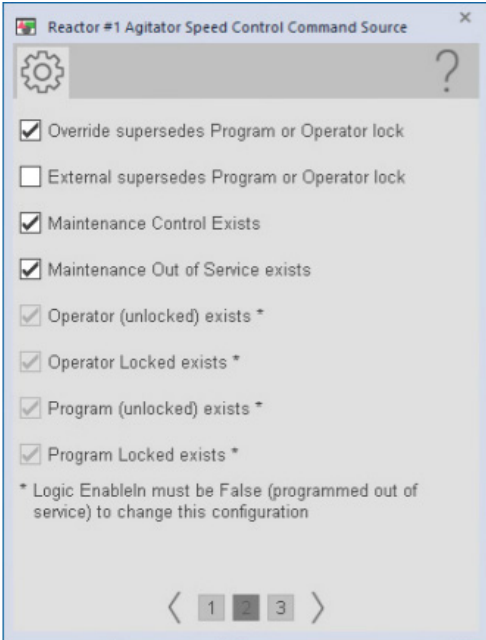
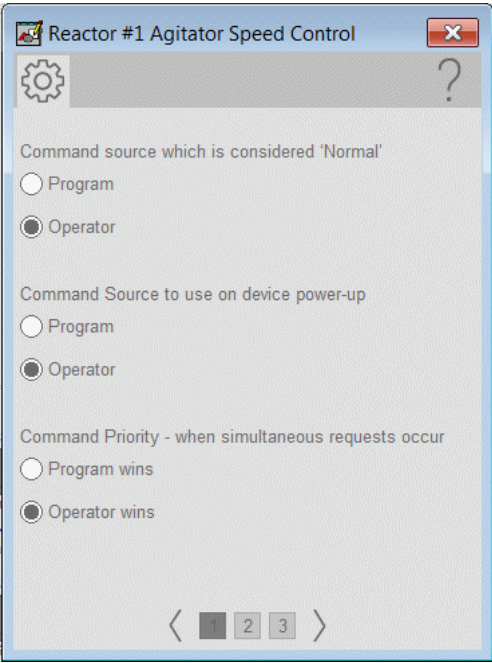
**Table 37 - Maintenance Buttons Description**

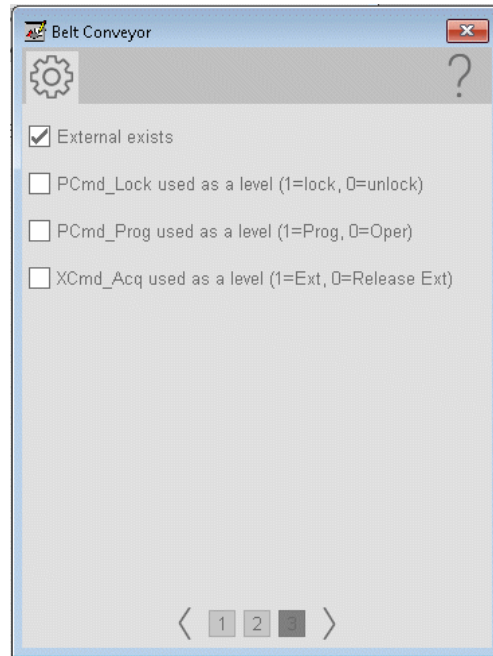
Graphic Symbol	Description
	Click to acquire Maintenance command source.
	Click to release Maintenance command source.
	Click to display Advanced Properties command source.

## Advanced Properties

Click the Advanced Properties button from the maintenance page to access the engineering tabs. There are three engineering tabs. The first page is the configuration for the Cfg\_ProgDefault parameter for the object, which sets the default command source when no command source is being requested.

From the other pages, you can configure the settings for additional command sources.





## Operator Prompt (P\_Prompt)


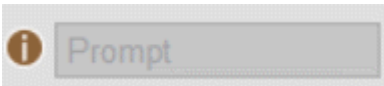
The P\_Prompt (Operator Prompt) Add-On Instruction is a universal mechanism for operator interaction that can be used within a control scheme. The instruction presents an operator with configurable message or data fields and accepts operator response data and confirmation. This instruction excludes display elements.

This document is for the visualization files, display elements, global objects, and HMI information. The operation of the Add-on Instructions and controller code is contained in publication [PROCES-RM013](#).

## Graphic Symbols

The following table describes the graphic symbols of the P\_Prompt.

**Table 38 - Graphic Symbols Description**

Graphic Symbol	Description
	Standalone prompt button that assumes the P_Prompt instruction is present and the button is always visible. The Prompt instruction controls the enabled state and alert indicator visibility of the button.
	Prompt display indicator for use on faceplates and displays for objects that possibly do not have a prompt instruction.

# Faceplates

The P\_Prompt instruction has three faceplates: Selection, Configuration, and Response.

## Selection Faceplate

The Prompt Selection display provides access to the configuration dialog box for a given prompt configuration in the prompts array by clicking the corresponding browse button.

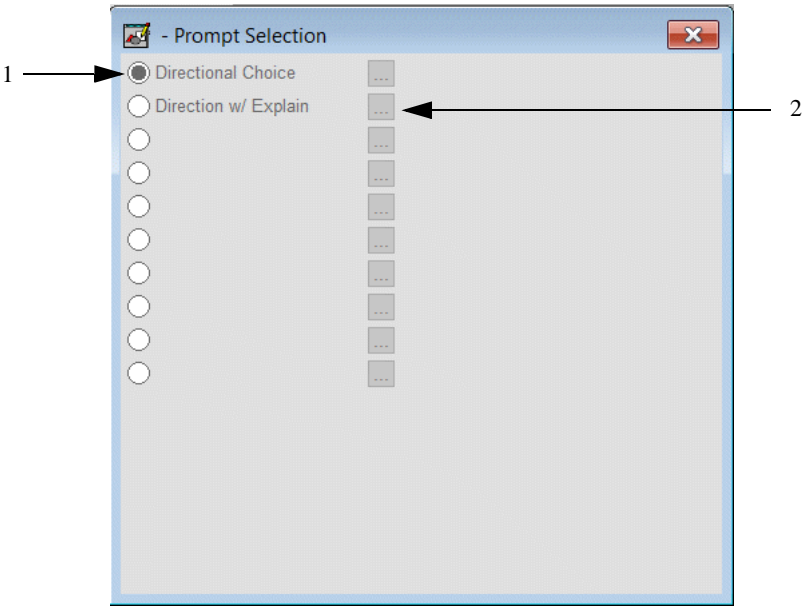


Table 39 - Selection Faceplate Description

Item	Description
1	Click the radio button to select a prompt.
2	Click to open the configuration faceplate.

### Configuration Faceplate

The Prompt Configuration dialog box has four sections to configure a prompt. The sections are Display Values, Input Values, Selection Options, and Response Prompts.

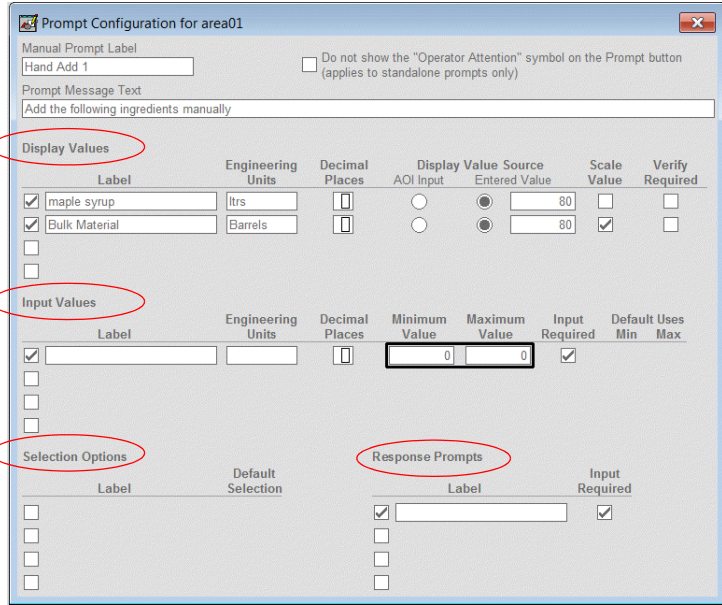


Figure 8 - Display Values

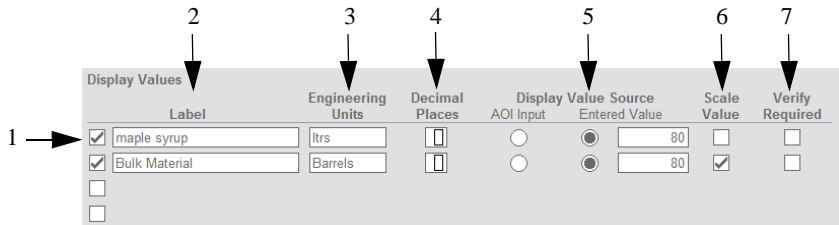
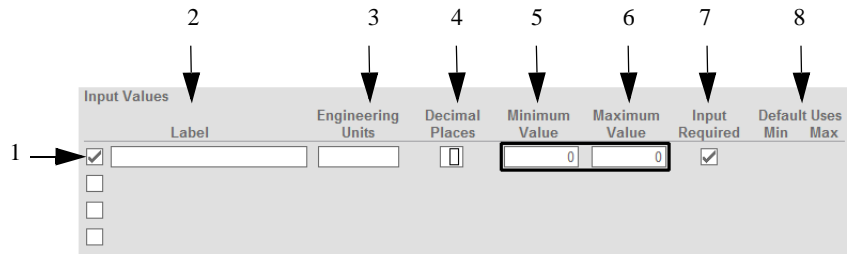


Table 40 - Display Values Description

Item	Description
1	Check to enable a label text field.
2	Type a label.
3	Type an engineering unit.
4	Type the decimal places to display.
5	Check to either display a value from the prompt 'AOI Input' or the value that you enter in the box that appears.
6	Check to scale the value by the entered value and the Inp_ScalePct.
7	Check to require the operator to verify the displayed value.

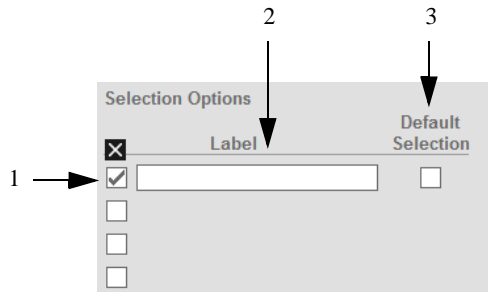
**Figure 9 - Input Values**



**Table 41 - Input Values Description**

Item	Description
1	Check to enable a label text box.
2	Type a label for the input value.
3	Type an engineering unit.
4	Type the decimal places to display.
5	Type a minimum value for the entry
6	Type a maximum value for the entry.
7	Check to require an operator to enter a value.
8	If an input is not required, click Minimum or Maximum to be used for the entry.

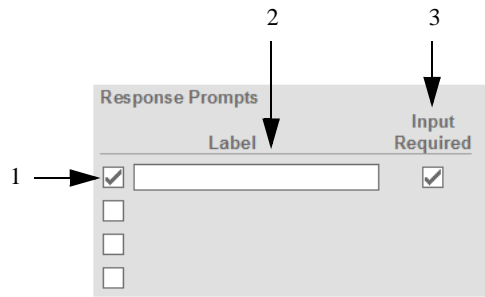
**Figure 10 - Selection Options**



**Table 42 - Selection Options Description**

Item	Description
1	Check to enable a label text box.
2	Check and type a label for the selection option.
3	Click to designate a selection as the default.

**Figure 11 - Response Prompts**

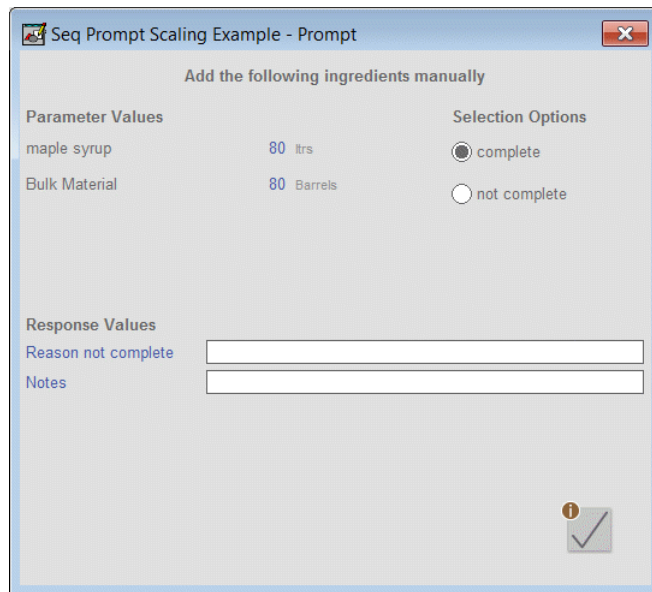


**Table 43 - Response Prompts Description**

Item	Description
1	Check to enable a label text box.
2	Check and type a label for the response prompt.
3	Check to require an input.

*Response Faceplate*

This faceplate lets the operator review and record data based on the prompt. All values are configured on the prompt configuration faceplate. The operator clicks the checkbox to continue.





# Boolean Logic with Snapshot (P\_Logic)

The P\_Logic (Boolean Logic with Snapshot) Add-On Instruction executes up to eight gates of configurable Boolean logic. Gate types available include AND, OR, XOR (Exclusive-OR), Set/Reset, Select, and Majority. Each gate provides up to four input conditions that are individually invertible. (The P\_Logic instruction does not need a NOT gate.)

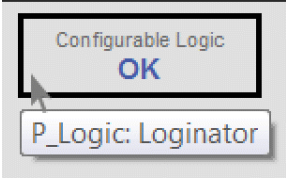
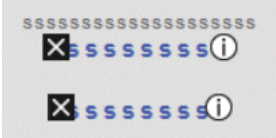
The P\_Logic Add-On Instruction also provides a snapshot capability. This capability enables it to record its current state with an optional time stamp. This snapshot can be taken upon change in output state, on Operator or Program command, or based on a logic loopback input.

This document is for the visualization files, display elements, global objects, and HMI information. The operation of the Add-on Instructions and controller code is contained in publication [PROCES-RM013](#).

## Display Elements

The P\_Logic Instruction has display elements (global objects) for use on process graphic displays. These elements provide you with the following:

- Information on the current state of the object
- Touch field to open the faceplate of the object
- Tooltip to display the configured tag and description of the object

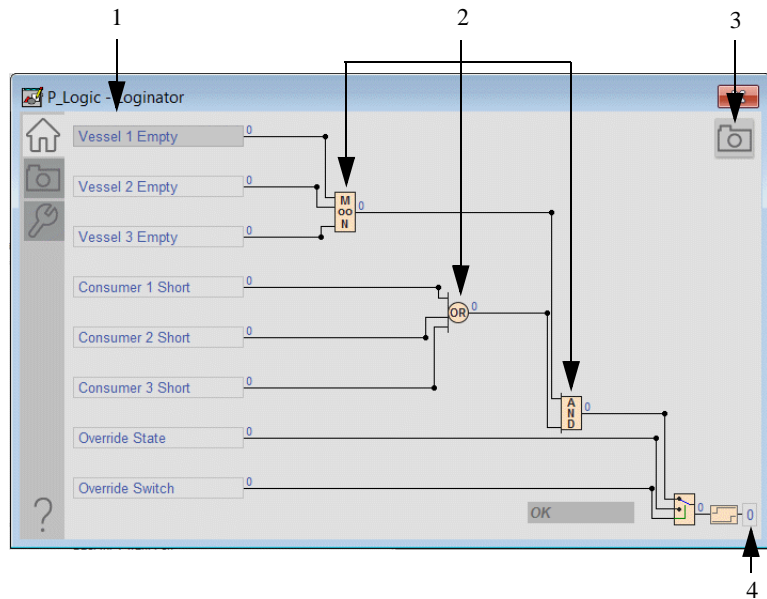


## Operator Tab

The Faceplate initially opens to the Operator (Home) tab. From here, an operator can monitor the device status and manually operate the device.

The Operator tab shows the following information:

- The eight Boolean inputs and eight logic gates, with each gate having a maximum of four sources.
- Configurable operator snapshot command button creates an image of the logic.
- Provides a progress indicator for the on-delay time and off-delay time for the output of the instruction. See [Maintenance Tab on page 84](#) for On-delay and off-delay configuration.



The following table describes the functions included on the Operator tab.

**Table 44 - Operator Tab Description**

Item	Description
1	Input Name: Click to navigate to the Input object faceplate.
2	Gates: Click one of the gates to access the Gate Configuration display for that gate.
3	Click to take a snapshot of the current state. <b>IMPORTANT:</b> When you take a snapshot, the View Snapshot tab is automatically displayed.

### View Snapshot Tab

The View Snapshot tab shows an image of the Operator faceplate when the snapshot was taken. The background of the display turns from gray to white to indicate capture. The View Snapshot has the same functionality as the operator faceplate plus a Reset button.

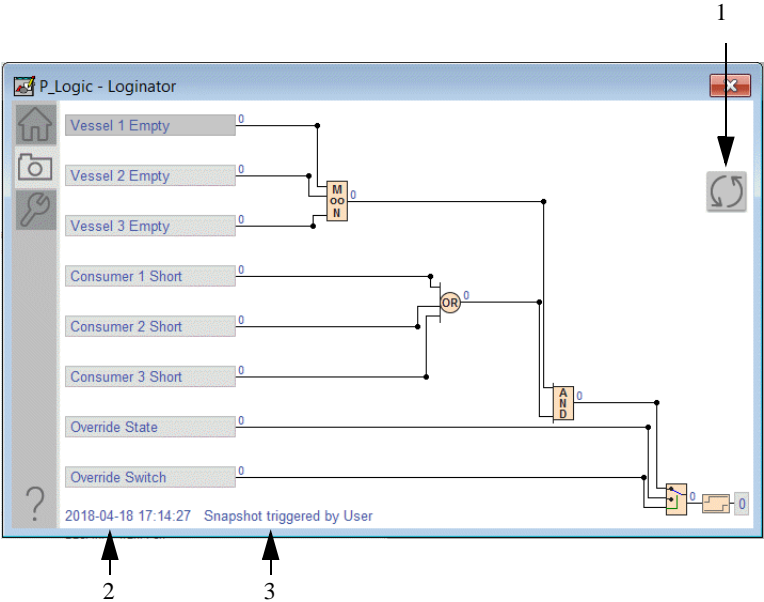
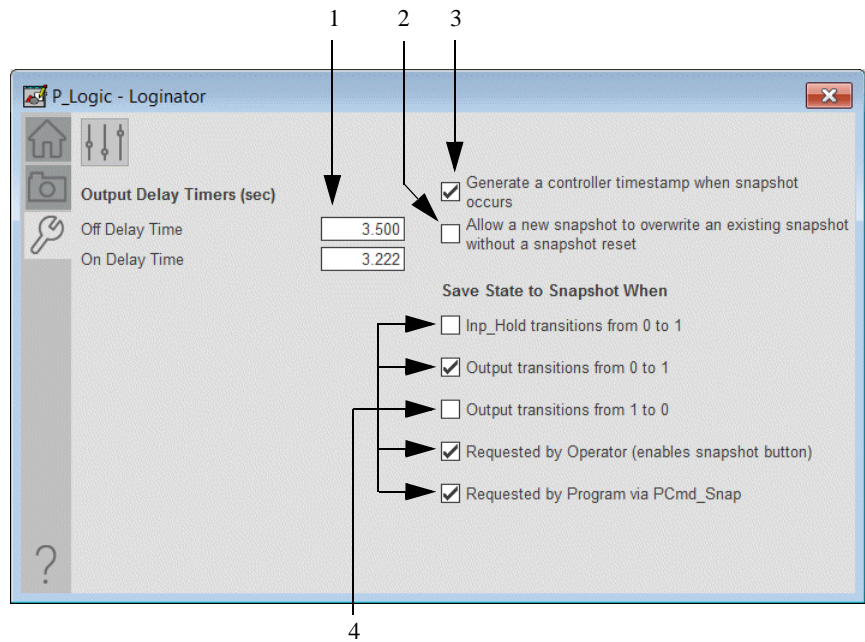


Table 45 - View Snapshot Tab Description

Item	Description
1	Click to reset the snapshot function so that another snapshot can be triggered. <b>IMPORTANT:</b> If 'Allow a new snapshot to overwrite an existing snapshot without a snapshot reset' is checked on the maintenance tab, a reset is not required trigger another snapshot.
2	Time stamp
3	Identifies how the snapshot was triggered.

## Maintenance Tab

Maintenance personnel use the information and controls on the Maintenance tab to adjust device parameters. They also troubleshoot and temporarily work around device problems, and disable the device for routine maintenance.



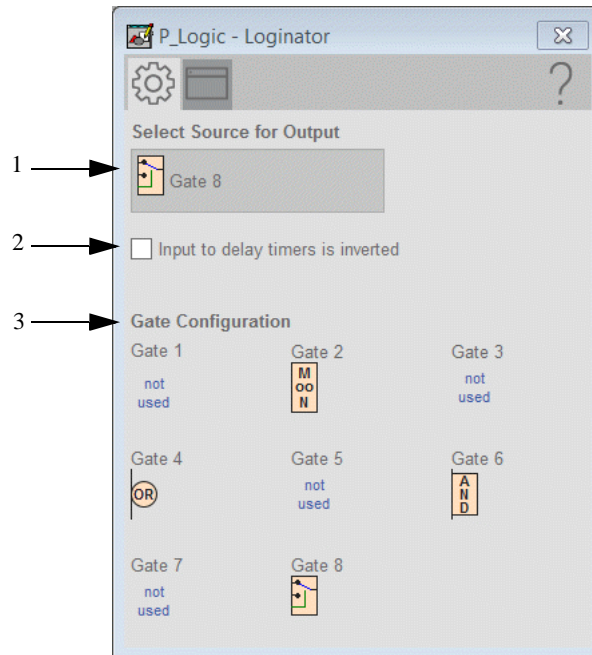
**Table 46 - Maintenance Tab Description**

Item	Description
1	Type a value for the off-delay time and the on-delay time.
2	Check to allow a new snapshot to be triggered without a reset of the previous snapshot.
3	Check to generate a time stamp whenever a snapshot triggers.
4	Check to trigger a snapshot when the designated condition is met.

## Advanced Properties Display

Click the Advanced Properties button to display the engineering and HMI configuration tabs. The Advanced Properties Display provides access to device configuration parameters and ranges, and options for device and I/O setup. The engineering tab and the HMI configuration tab can be reached from the Advanced Properties Display. This tab is used for initial system commissioning or later system changes.

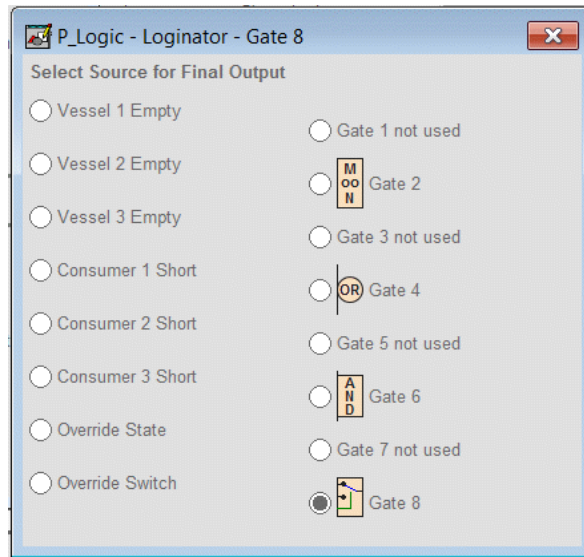
### Engineering Tab



**Table 47 - Engineering Tab Description**

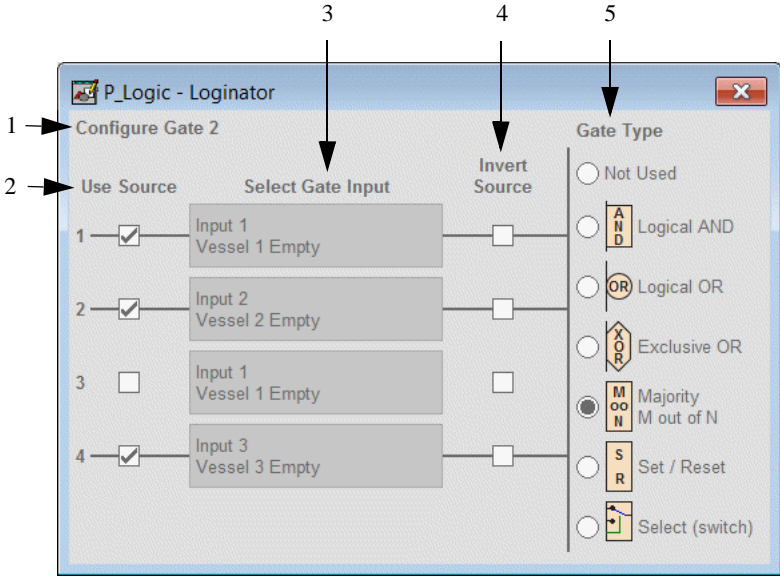
Item	Description
1	Click to open the faceplate to select the output source. See <a href="#">Output Source on page 86</a>
2	Check to invert the selected output before it is passed to the output delay timers
3	Click to open the Gate Configuration faceplate.

Figure 12 - Output Source



## Gate Configuration Display

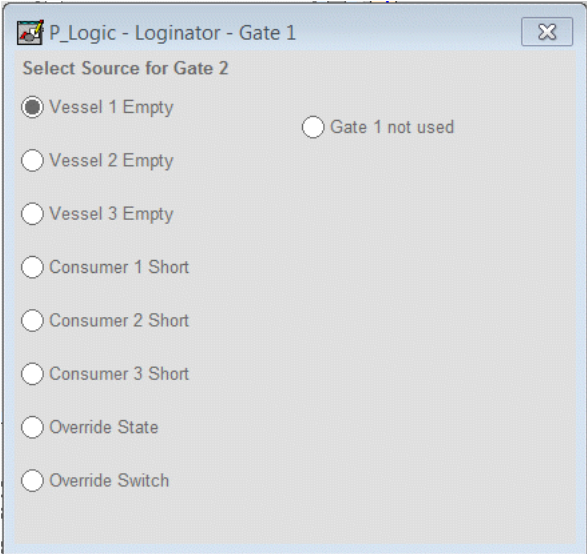
The gate configuration display appears if a gate is clicked in the Operator, View Snapshot, or Engineering tabs.



**Table 48 - Gate Configuration Display Description**

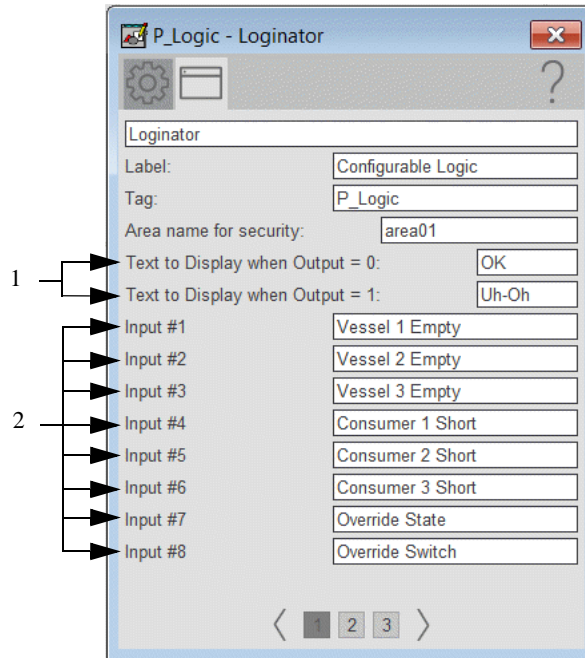
Item	Description
1	Displays the gate being configured.
2	Check to select which inputs of the gate are enabled (1...4).
3	Click to select the inputs for the gate. See <a href="#">Gate Input Source on page 87</a>
4	Check to invert the source that enters the gate.
5	Check to select a gate type.

**Figure 13 - Gate Input Source**



### HMI Configuration Tab

Configure the description, label, tag, and security area for the device. See [Basic Faceplate Attributes on page 32](#) for the description of the common attributes. The tab is separated into three pages. Page 1 contains the common information and name conventions. Page 2 and three allow for navigation to the objects.



**Table 49 - HMI Configuration Page 1 Description**

Item	Description
1	Type the text to display on the faceplate when output = 0 or 1
2	Type a description for each input.



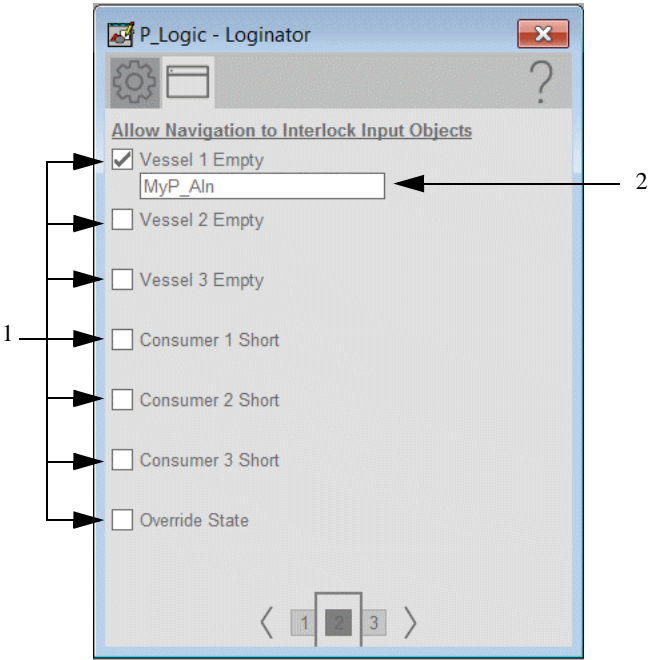
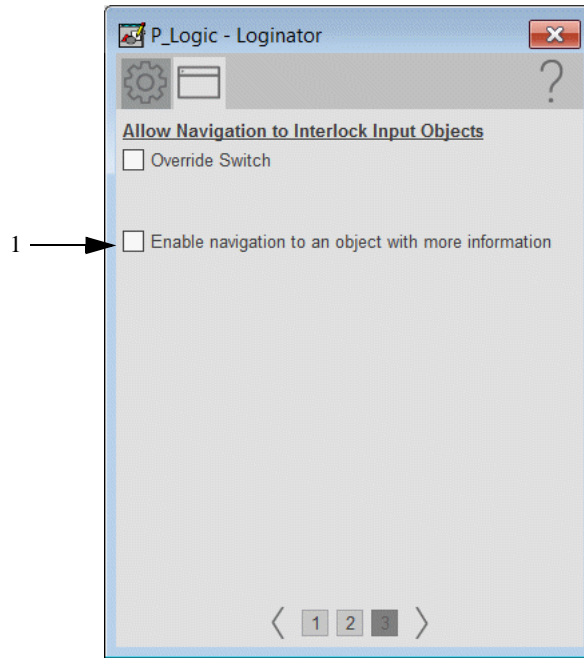


Table 50 - HMI Configuration Page 2 Description

Item	Description
1	Check to enable navigation to input object.
2	Type the tag name of the input object.



**Table 51 - HMI Configuration Page 3 Description**

Item	Description
1	<p>Check to enable navigation to an object with more information (Cfg_HasMoreObj is set to true.)</p> <p>This can be configured to navigate to an AOI backing tag or a UDT tag that has HMI_Type and HMI_Lib defined.</p> <p>For example, there is a motor with the tag name P_101 and there is a need to have the more information button navigate to the parent P_LLS object. A tag is created for the P_LLS object that is given the alias P101_More. When the more information button is pressed on the motor, it links to P101_More. This will open the faceplate for the LLS object.</p>

## I/O Processing Family

The Process Objects in this group provide analog and discrete input/output signal processing. Pressure/temperature compensated flow calculations and cylindrical tank level interpolations are also provided. This document is for the visualization files, display elements, global objects, and HMI information. The operation of the Add-on Instructions and controller code is contained in publication [PROCES-RM013](#).

### Display Elements

A display element (global object) is created once and can be referenced multiple times on multiple displays in an application. When changes are made to the original (base) object, the instantiated copies (reference objects) are automatically updated.



Use of global objects with tag structures in the ControlLogix® system aid consistency and save engineering time.

The items in [Table 52](#) are common to the following Add-On Instructions.


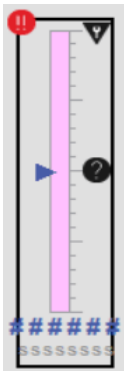
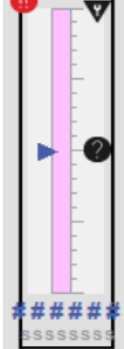
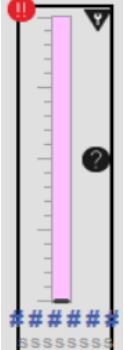
- Basic Analog Input (P\_AIn)
- Advanced Analog Input (P\_AInAdv)
- Dual Sensor Analog Input (P\_AInDual)
- Multiple Analog Input (P\_AInMulti)

If additional display elements are used, they are documented in the appropriate section.

**Table 52 - I/O Common Display Elements Descriptions**

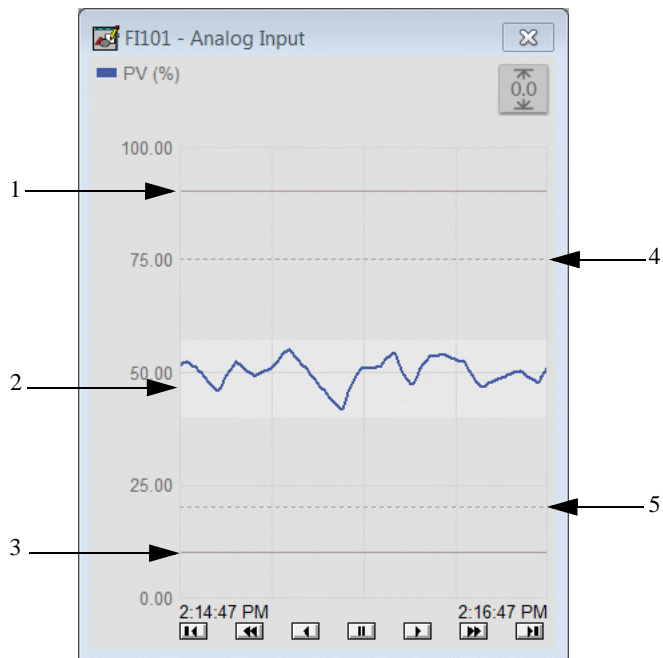
Name	Display Element	Description
GO_P_AIn		Standard analog-input global object.
GO_P_AIn_Trend		Analog input with a trend of the Process Variable and limits (high-high, high, low, and low-low).

**Table 52 - I/O Common Display Elements Descriptions**

Name	Display Element	Description
GO_P_AIn_TrendWCapture		Analog Input with Trend of Process Variable and limits (high-high, high, low, and low-low) plus a light gray capture area.
GO_P_AIn_Indicator		Process Variable indicated by a moving triangle. The graphic display includes limits that are displayed with filled bars.
GO_P_AIn_IndicatorWCapture		This object is the same as the GO_P_Ain_Indicator plus a light gray minimum/maximum capture area.
GO_P_AInX		Process Variable that is displayed as a bar graph. The graphic display includes limits that are displayed as lines on the graph.

## Trends Tab

The Trends tab shows trend charts of key device data over time. These faceplate trends provide a quick view of current device performance to supplement, but not replace, dedicated historical or live trend displays. The trends displays are common across all I/O Processing Add-On Instructions. For basic trends tab functionality, See [Trends Display on page 37](#).



**Table 53 - Trends Tab Description**

Item	Description
1	High-high threshold value.
2	Process Variable (%) value.
3	Low-low threshold value.
4	High threshold value.
5	Low threshold value.

## Basic Analog Input (P\_AIn)

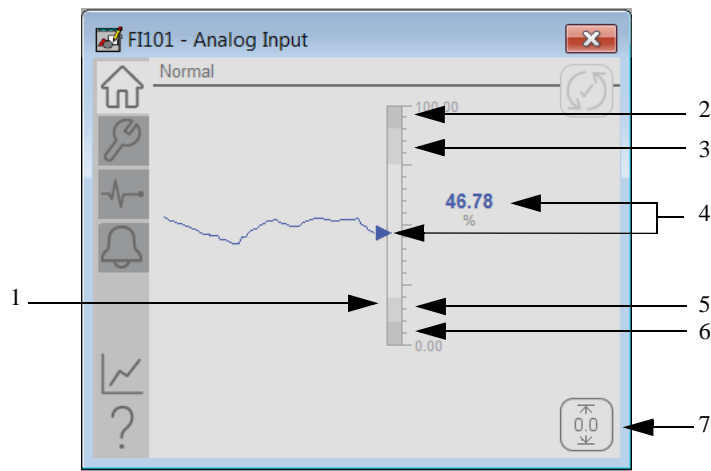
The P\_AIn Add-On Instruction monitors one analog value, typically from a channel of an analog input module, and provides alarms when the analog value exceeds user-specified thresholds (high and low).

The Analog Input instruction also provides capabilities for linear scaling of an analog input value from raw (input) units to engineering (output) units. The instruction can enter a substitute process variable, providing handling of an out-of-range or faulted input.

This document is for the visualization files, display elements, global objects, and HMI information. The operation of the Add-on Instructions and controller code is contained in publication [PROCES-RM013](#).

### Operator (Home) Tab

The Faceplate initially opens to the Operator (Home) tab. From here, an operator can monitor the device status and manually operate the device.



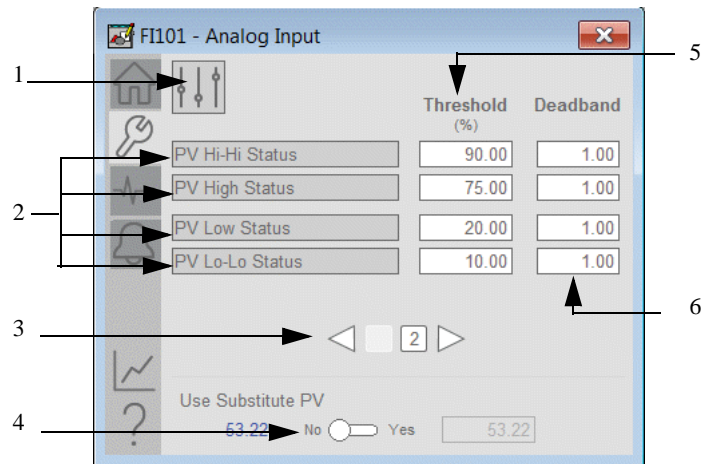
The following table describes the functions included on the Home tab.

**Table 54 - Operator Tab Description**

Item	Description
1	Current Process Variable Graph: Bar graph for the current Process Variable. High-high (HH) and low-low (LL) ranges are shown in dark gray and these ranges change colors based on alarm severity if the threshold is exceeded. High and Low ranges are shown in medium gray, and these ranges also change color based on alarm severity.
2	High-high Thresholds
3	High Threshold
4	Current Process Variable that is shown as an arrow on the graph and numerically.
5	Low Thresholds
6	Low-low Thresholds
7	Clear capture minimum / maximum extents

## Maintenance Tab

Maintenance personnel use the information and controls on the Maintenance tab to adjust device parameters, troubleshoot, temporarily work around device problems, and disable the device for routine maintenance.

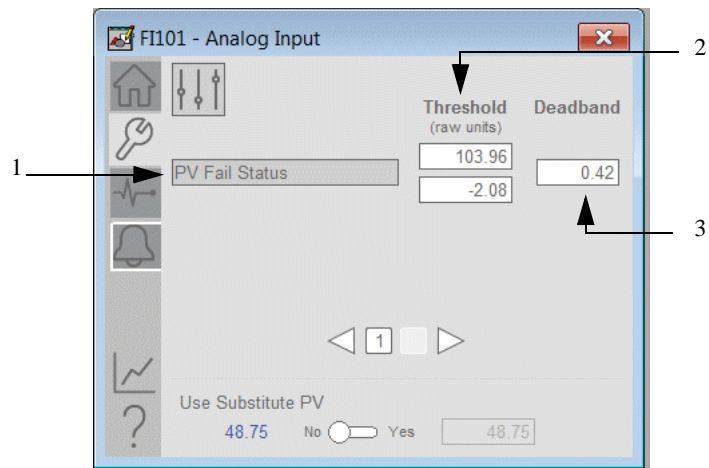


**IMPORTANT** Click a threshold name to open the P\_Gate faceplate. From the P\_Gate faceplate, you can configure and perform additional operations for each alarm, including Gate Delay, Status On-delay, Status Off-delay, and Threshold Name.

The following table shows the functions on the Maintenance tabs.

**Table 55 - Maintenance Tab Page 1 Description**

Item	Description
1	Click this button to open the advanced properties. The engineering and HMI configuration settings become available.
2	Threshold Name: Click a threshold name to open the associated P_Gate faceplate.
3	Page Identifier
4	Use Substitute PV: Click to input a substitute process variable.
5	Type the threshold (trip point) for analog input alarms.
6	Type the deadband (hysteresis) that applies to each alarm limit. Deadband helps prevent a noisy signal from generating numerous spurious alarms. Example: If the High alarm limit is 90.0 and the High alarm deadband is 5, once the signal rises above 90.0 and generates a High alarm. The signal must fall below 85.0 (90.0 minus 5.0) for the alarm to clear.



**Table 56 - Maintenance Tab Page 2 Description**

Item	Description
1	Threshold Name: Click a threshold name to open the associated P_Gate faceplate.
2	Type the threshold (trip point) minimum / maximum
3	Process variable fail deadband. Type the deadband (hysteresis) that is applied to each alarm limit. Deadband helps prevent a noisy signal from generating numerous spurious alarms. <b>Example:</b> If the High alarm limit is 90.0 and the High alarm deadband is 5, once the signal rises above 90.0 and generates a High alarm. The signal must fall below 85.0 (90.0 minus 5.0) for the alarm to clear.

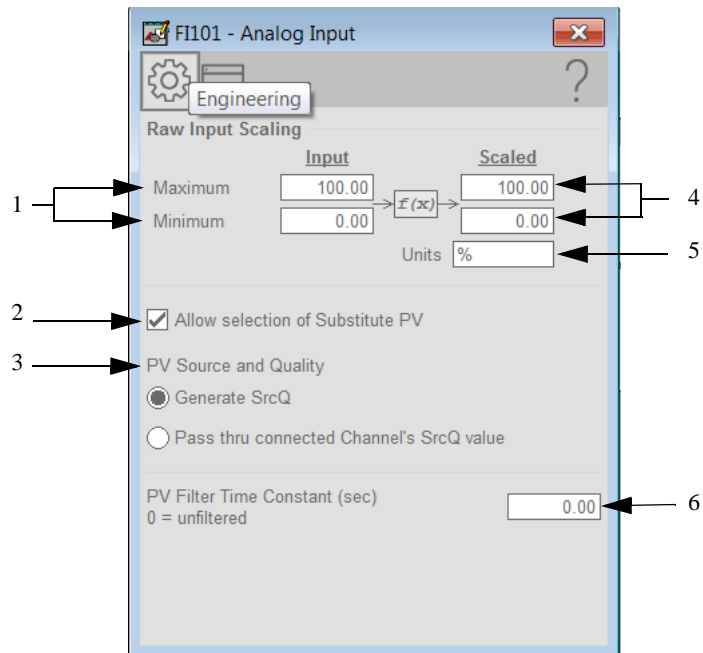


## Advanced Properties Display

The Advanced Properties Display opens to the engineering settings. The Advanced Properties Display provides access to device configuration parameters and ranges, and options for device and I/O setup. This tab is used for initial system commissioning or later system changes.

### Engineering Tab

In the engineering settings, you can configure the Process Variable unit for the device.



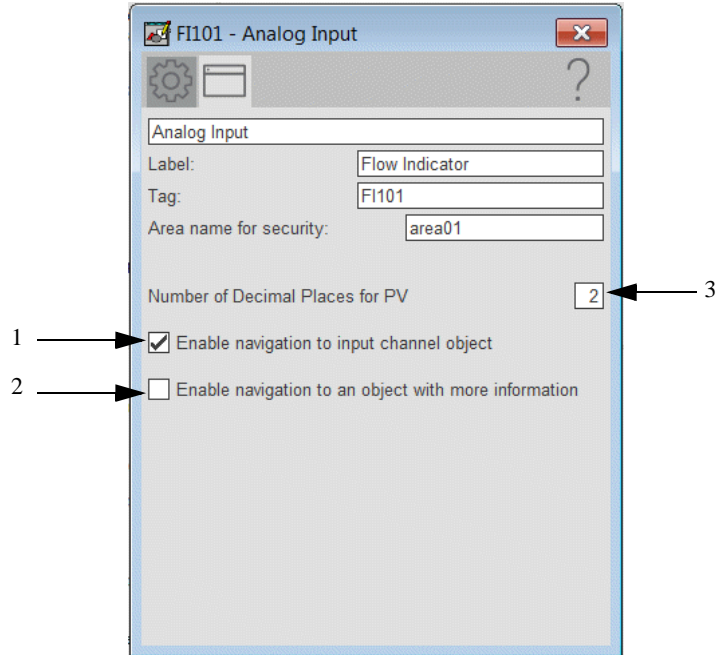
The following table lists the functions on the engineering tab.

**Table 57 - Engineering Tab Description**

Item	Description
1	<p>Input (unscaled) minimum and maximum</p> <p>These parameters must be set to the range of the signal that is connected to the Inp_Process Variable Input. The raw minimum default is 0.0 and the raw maximum default is 100.0.</p> <p><b>Example:</b> If your input card provides a signal from 4.0...20.0mA, set Cfg_InpRawMin to 4.0 and Cfg_InpRawMax to 20.0. The raw minimum/maximum and engineering units minimum/maximum are used for scaling to engineering units.</p>
2	<p>Check to allow the Substitute Process Variable Maintenance function.</p> <p>Clear this checkbox to disallow the Substitute Process Variable Maintenance function (default).</p>
3	<p>PV Source and Quality</p> <p><b>Generate SrcQ:</b> This instruction determines the Process Variable quality using Inp_PVBad, Inp_PVUncertain, and the PV value (out of range, infinite or not a number)</p> <p><b>Pass thru connected Channel's SrcQ value:</b> This instruction uses the Source and Quality (SrcQ) value that is provided by an upstream object (such as P_AIChan) via Inp_PVSrcQ to determine the PV source and quality.</p>
4	<p>EU minimum and maximum for scaling</p> <p>These parameters must be set to match the Process Variable range of the input signal that is connected to Inp_PV. The Process Variable engineering units minimum default is 0.0 and the Process Variable engineering units maximum is 100.0.</p> <p><b>Example:</b> If your input card provides a signal from 4...20 mA that represents -50...+250 °C, set Cfg_PVEUMIN to -50.0 and Cfg_PVEU maximum to 250.0. The raw minimum/maximum and Process Variable engineering units minimum/maximum are used for scaling to engineering units.</p>
5	<p>Type engineering units for display on the HMI. Percent (%) is the default.</p>
6	<p>Type the Process Variable filter time constant.</p> <p>If the time constant is 0, the Process Variable is unfiltered.</p>

## HMI Configuration Tab

The HMI configuration tab provides access to displayed text, and faceplate-to-faceplate navigation settings. See [Basic Faceplate Attributes on page 32](#) for the description of the common attributes.

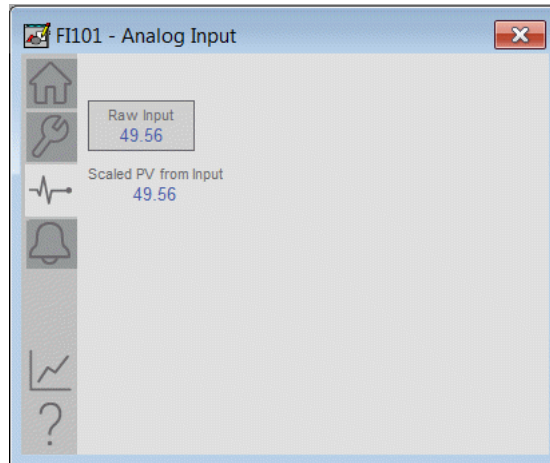


**Table 58 - HMI Configuration Tab Description**

Item	Description
1	Check to enable navigation to an upstream channel object (for example, P_). <b>IMPORTANT:</b> The name of the Channel object in the controller must be the name of the object with the suffix '_Chan'. For example, if your P_AIn object has the name 'AIn123', then its Channel object must be named 'AIn123_Chan'.
2	Check to enable navigation to an object with more information (Cfg_HasMoreObj is set to true.) This can be configured to navigate to an AOI backing tag or a UDT tag that has HMI_Type and HMI_Lib defined. For example, there is a motor with the tag name P_101 and there is a need to have the more information button navigate to the parent P_LLS object. A tag is created for the P_LLS object that is given the alias P101_More. When the more information button is pressed on the motor, it links to P101_More. This will open the faceplate for the LLS object.
3	Set the number of decimal places for the Process Variable.

## Diagnostics Tab

The Diagnostic tab provides indications to diagnose device problems. This tab includes device warnings and faults, warning and fault history, and predictive/preventive maintenance data. The initial faceplate shows the raw input process variable.



Click the raw input button to open the analog channel quality faceplate. This tab provides an overview of the process variable. For more information on the analog channel faceplate, See [Analog Input Channel \(P\\_AIChan\) on page 110](#).

## Alarms Tab

The Alarms tab displays each configured alarm. The icon on the tab for the alarms page changes color to show the current active alarm status. A blinking alarm icon indicates that one or more alarms must be acknowledged or the device must be reset. See [Common Alarm Block \(P\\_Alarm\) on page 66](#) for more information.

## Advanced Analog Input (P\_AInAdv)

The P\_AInAdv Add-On Instruction monitors one analog value, typically from an Analog Input I/O module. The Add-On Instruction has the same basic features as P\_AIn. See [Basic Analog Input \(P\\_AIn\) on page 94](#). This instruction has the following advanced features that are not included in the basic analog input:

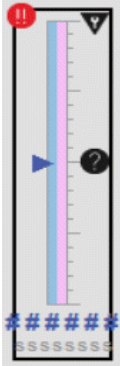
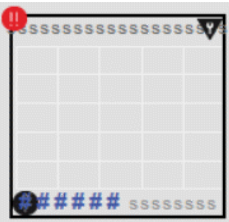
- Square root scaling to provide positive or negative flow values
- Calculation of the Process Variable rate of change and configurable high rate of change alarming
- Alarms for deviation from a reference value

This document is for the visualization files, display elements, global objects, and HMI information. The operation of the Add-on Instructions and controller code is contained in publication [PROCES-RM013](#).


### Display Elements

A display element (global object) is created once and can be referenced multiple times on multiple displays in an application. When changes are made to the original (base) object, the instantiated copies (reference objects) are automatically updated. Use of global objects, with tag structures, aid consistency and save engineering time.

**Table 59 - P\_AInAdv Display Elements Description**

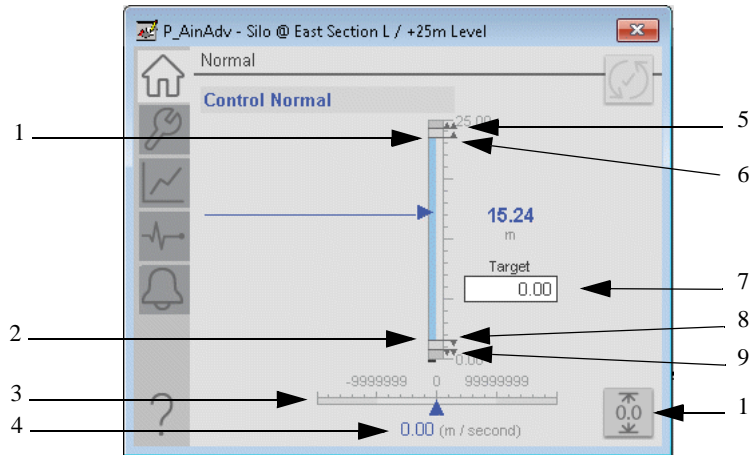
Display Element Name	Display Element	Description
GO_P_AInAdv_Indicator		A moving triangle indicates the process variable. The graphic display includes limits that are displayed with filled bars plus a cyan target range (for deviations).
GO_P_AInAdvTrend		This graphic symbol includes a trend with target lines and is intended to be used for the Advanced Analog Input Add-On Instruction.

**Table 59 - P\_AInAdv Display Elements Description**

Display Element Name	Display Element	Description
GO_AInAdv_IndicatorWC apture		<p>A moving triangle indicates the process variable. The graphic display includes limits that are displayed with filled bars plus a cyan target range (for deviations) and a light gray minimum/maximum capture area.</p>

## Operator Tab

The Faceplate initially opens to the Operator (Home) tab. From here, an operator can monitor the device status and manually operate the device. The home page contains the same basic information as the P\_AIn Add-On Instruction. See [Basic Analog Input \(P\\_AIn\) on page 94](#). Additional information is identified in the following diagram.



**Table 60 - P\_AInAdv Home Tab Description**

Item	Description
1	High Deviation limit: the label background that changes color based on alarm severity when exceeded.
2	Low Deviation limit: the label background that changes color based on alarm severity when exceeded.
3	The rate of change bar graph (visible if Rate of Change calculations is enabled on the engineering tab).
4	The rate of change value (visible if Rate of Change calculations is enabled on the engineering tab).
5	Control High-High limit
6	Control High limit
7	Process Variable target.
8	Control Low limit
9	Control Low-Low limit
10	Reset Rate of Change value to zero.

## Maintenance Tab

Maintenance personnel use the information and controls on the Maintenance tab to adjust device parameters, troubleshoot and temporarily work around device problems. The maintenance tab for the P\_AInAdv Add-On Instruction has three pages. The first page contains the threshold and deadband information and is the same as the P\_AIn Add-On Instruction. See [Basic Analog Input \(P\\_AIn\) on page 94](#). Additional information for this instruction is on pages two ... four and can be seen in the following diagrams.

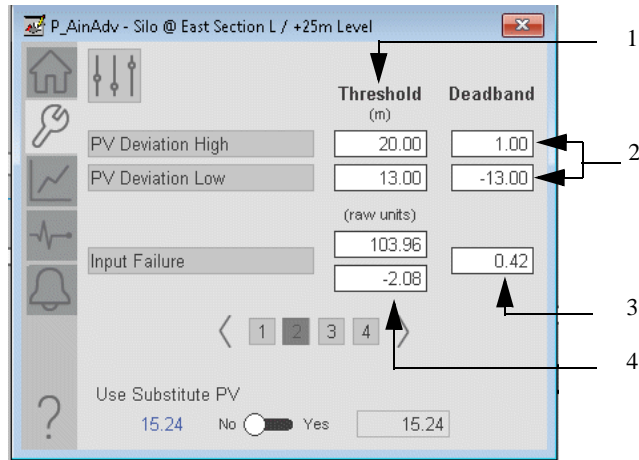
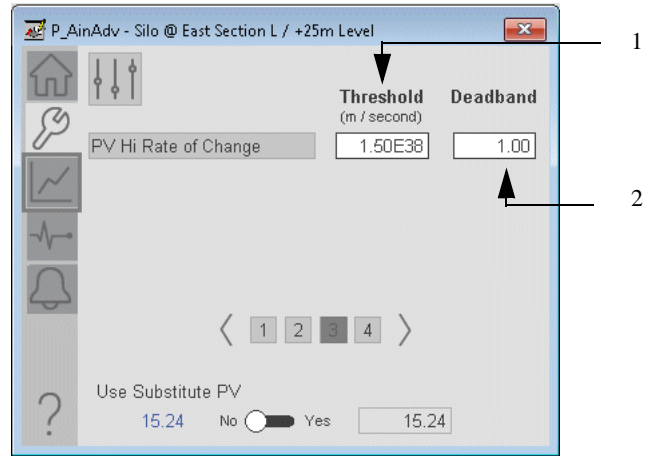


Table 61 - Maintenance Tab Page 2 Description

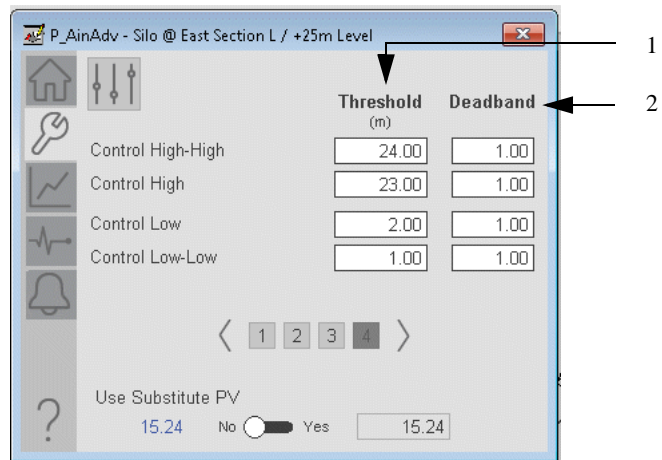
Item	Description
1	Process variable high/low deviation threshold. Type the threshold (trip point) for analog input alarms.
2	Process variable high/low deviation deadband. Type the deadband (hysteresis) that is applied to each alarm limit. Deadband helps prevent a noisy signal from generating numerous spurious alarms. <b>Example:</b> If the High alarm limit is 90.0 and the High alarm deadband is 5, once the signal rises above 90.0 and generates a High alarm. The signal must fall below 85.0 (90.0 minus 5.0) for the alarm to clear.
3	Process variable fail deadband. Type the deadband (hysteresis) that is applied to each alarm limit. Deadband helps prevent a noisy signal from generating numerous spurious alarms. <b>Example:</b> If the High alarm limit is 90.0 and the High alarm deadband is 5, once the signal rises above 90.0 and generates a High alarm. The signal must fall below 85.0 (90.0 minus 5.0) for the alarm to clear.
4	Process variable fail threshold in raw units.





**Table 62 - Maintenance Tab Page 3 Description**

Item	Description
1	Process variable high rate of change threshold. Type the threshold (trip point) for the rate of change alarm.
2	Process variable high rate of change deadband. Type the deadband (hysteresis) that is applied to each alarm limit. Deadband helps prevent a noisy signal from generating numerous spurious alarms. <b>Example:</b> If the High alarm limit is 90.0 and the High alarm deadband is 5, once the signal rises above 90.0 and generates a High alarm. The signal must fall below 85.0 (90.0 minus 5.0) for the alarm to clear.



**Table 63 - Maintenance Tab Page 4 Description**

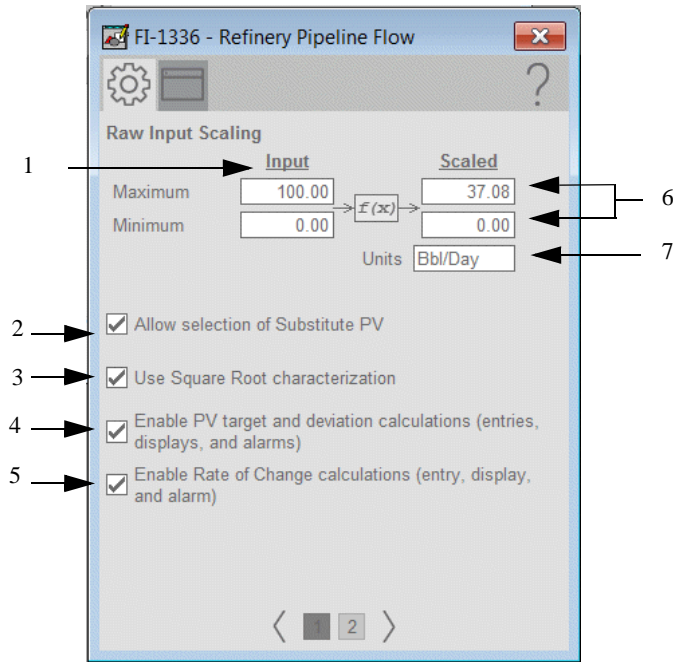
Item	Description
1	Type the deadband (hysteresis) that is applied to each Control Limit.
2	Type the threshold (trip point) for the Control Limit.

## Advanced Properties Display

The Advanced Properties Display provides access to device configuration parameters and ranges, and options for device and I/O setup. The engineering tab and the HMI configuration tab are reached from the Advanced Properties Display. This tab is used for initial system commissioning or later system changes.

### Engineering Tab

Use the engineering tab to configure the Process Variable unit for the device.



**Table 64 - Engineering Tab Page 1 Description**

Item	Description
1	Input (unscaled) minimum and maximum These parameters must be set to the range of the signal that is connected to the Inp_Process Variable Input. The raw minimum default is 0.0 and the raw maximum default is 100.0. <b>Example:</b> If your input card provides a signal from 4.0...20.0mA, set Cfg_InpRawMin to 4.0 and Cfg_InpRawMax to 20.0. The raw minimum/maximum and engineering units minimum/maximum are used for scaling to engineering units.
2	Check to allow the Substitute Process Variable Maintenance function. Clear this checkbox to disallow the Substitute Process Variable Maintenance function (default).
3	Check to use the square root characterization for a differential pressure input to read flow. Clear this checkbox (default) to use linear scaling.
4	Check to enable target entry, deviation calculations, display, and alarms.

Table 64 - Engineering Tab Page 1 Description

Item	Description
5	Check to enable Rate of Change calculations, display, and alarms.
6	<p>EU minimum and maximum for scaling</p> <p>These parameters must be set to match the Process Variable range of the input signal that is connected to Inp_PV. The Process Variable engineering units minimum default is 0.0 and the Process Variable engineering units maximum is 100.0.</p> <p><b>Example:</b> If your input card provides a signal from 4...20 mA that represents -50...+250 °C, set Cfg_PVEUMIN to -50.0 and Cfg_PVEU maximum to 250.0. The raw minimum/maximum and Process Variable engineering units minimum/maximum are used for scaling to engineering units.</p>
7	Type engineering units for display on the HMI.

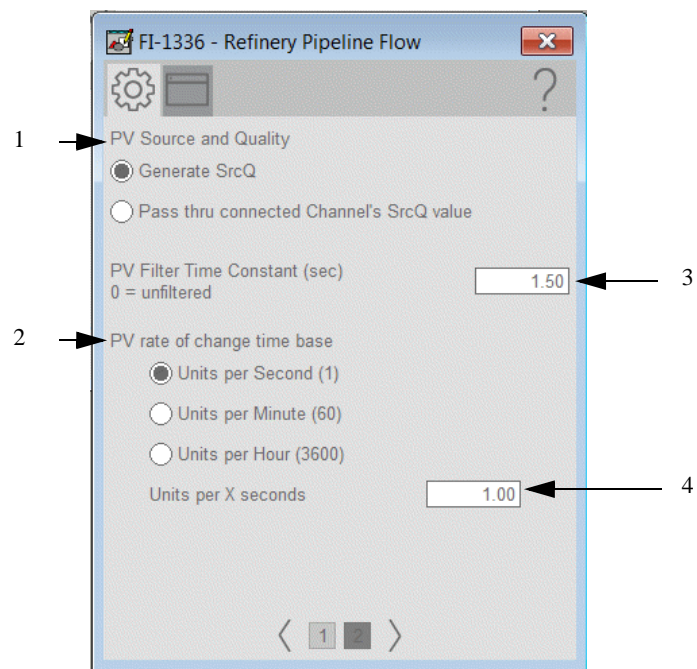
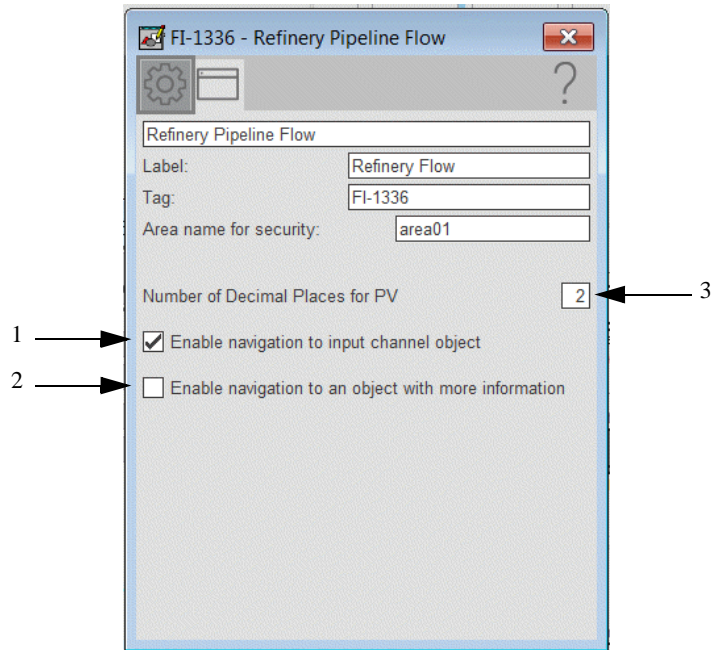


Table 65 - Engineering Tab Page 2 Description

Item	Description
1	<p>PV Source and Quality</p> <p><b>Generate SrcQ:</b> This instruction determines the Process Variable quality using Inp_PVBad, Inp_PVUncertain, and the PV value (out of range, infinite or not a number)</p> <p><b>Pass thru connected Channel's SrcQ value:</b> This instruction uses the Source and Quality (SrcQ) value that is provided by an upstream object (such as P_AIChan) via Inp_PVSrcQ to determine the PV source and quality.</p>
2	Check the appropriate time base for seconds, minutes, or hours.
3	Type the time in seconds for the process variable filter time constant.
4	Process variable rate of change time base in units.

### HMI Configuration Tab

See [Basic Faceplate Attributes on page 32](#) for the description of the common attributes.

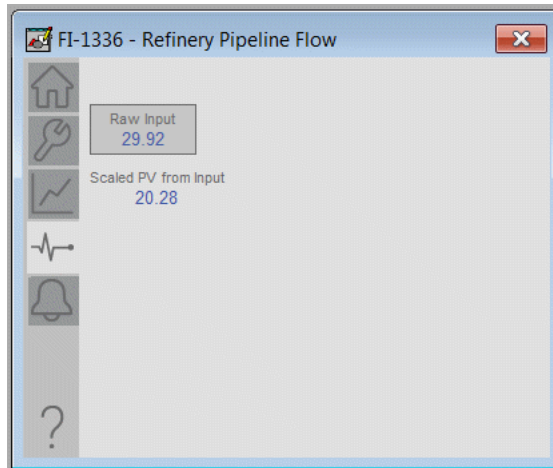


**Table 66 - HMI Configuration Tab Description**

Item	Description
1	Check to enable navigation to an upstream channel object (for example, P_AIChan). <b>IMPORTANT:</b> The name of the Channel object in the controller must be the name of the object with the suffix '_Chan'. For example, if your P_AInAdv object has the name 'AInAdv123', then its Channel object must be named 'AInAdv123_Chan'.
2	Check to enable navigation to an object with more information (Cfg_HasMoreObj is set to true.) This can be configured to navigate to an AOI backing tag or a UDT tag that has HMI_Type and HMI_Lib defined. For example, there is a motor with the tag name P_101 and there is a need to have the more information button navigate to the parent P_LLS object. A tag is created for the P_LLS object that is given the alias P101_More. When the more information button is pressed on the motor, it links to P101_More. This will open the faceplate for the LLS object.
3	Set the number of decimal places for the Process Variable.

## Diagnostics Tab

The Diagnostic tab provides indications to diagnose device problems. This tab includes specific reasons a device is 'Not Ready', device warnings and faults, warning and fault history, and predictive/preventive maintenance data. The initial faceplate shows the raw input process variable.



Click the raw input button to open the analog channel quality faceplate. This tab provides an overview of the process variable. For more information on the analog channel faceplate, See [Analog Input Channel \(P\\_AIChan\) on page 110](#).

## Alarms Tab

The Alarms tab displays each configured alarm. The icon on the tab for the alarms page changes color to show the current active alarm status. A blinking alarm icon indicates that one or more alarms must be acknowledged or the device must be reset. See [Common Alarm Block \(P\\_Alarm\) on page 66](#) for more information.

## Analog Input Channel (P\_AIChan)

The P\_AIChan Add-On Instruction monitors one analog input channel and provides one configurable alarm. This instruction is associated with other instructions.

This document is for the visualization files, display elements, global objects, and HMI information. The operation of the Add-on Instructions and controller code is contained in publication [PROCES-RM013](#).

## Display Elements

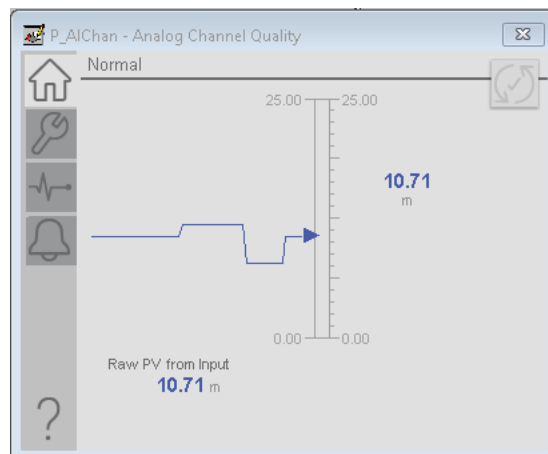
The P\_AIChan instruction is used in association with other device instructions to provide input monitoring functions. There are no dedicated display elements for this instruction. The P\_AIChan faceplate is called from other faceplates.

## Operator Tab

The faceplate initially opens to the Operator (Home) tab. From here, an operator can monitor the device status.

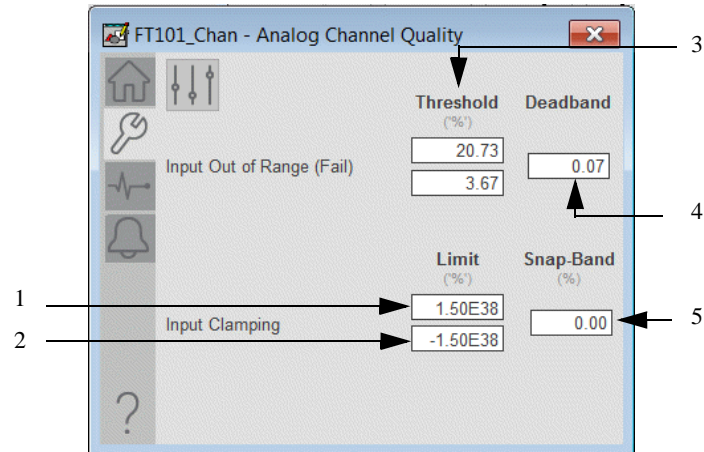
The Operator tab shows the following information:

- Current Process Variable value in raw and engineering units
- Process Variable status
- Input Source and Quality indicator



## Maintenance Tab

Maintenance personnel use the information and controls on the Maintenance tab to adjust device parameters. The following faceplate shows an example of the maintenance tab.



The following table shows the functions on the Maintenance tab.

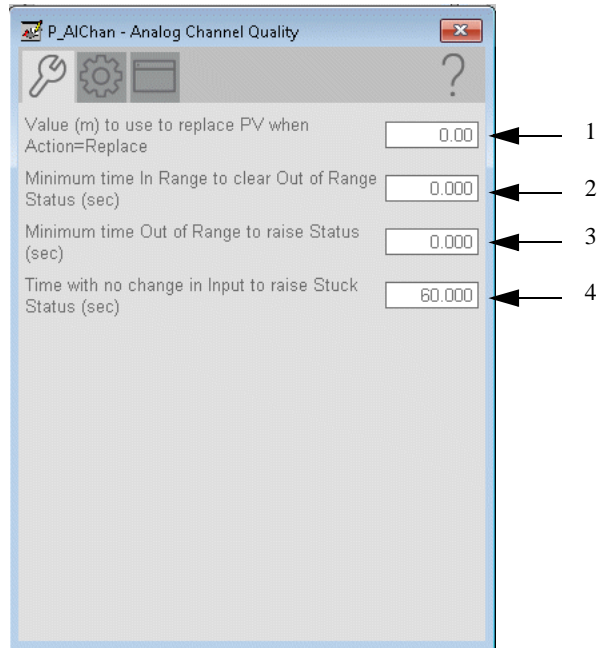
**Table 67 - Maintenance Tab Descriptions**

Item	Description
1	Type the high clamping limit for the Process Variable. This value clamps (limits) the Process Variable so it does not exceed this value. <b>IMPORTANT:</b> Out-of-Range detection uses the Process Variable value before clamping. This entry does not affect Out-of-Range detection
2	Type the low clamping limit for the Process Variable. This value clamps (limits) the Process Variable so it does not go below this value. <b>IMPORTANT:</b> Out-of-Range detection u
3	Type the thresholds that are considered out of range (failed). If the Process Variable is greater than or equal to the high threshold, it is considered out of range. If the Process Variable is less than or equal to the low threshold for the on-delay time, it is considered out of range.
4	Type the deadband to use with the out-of-range thresholds. If the Process Variable is less than the high threshold minus the deadband and the Process Variable is greater than the low threshold plus the deadband for the off-delay time, it is considered in range (not failed). The deadband must be greater than or equal to zero.
5	Type the snap-band to use with the Input Clamping Limits.

## Advanced Properties Display

The Advanced Properties Display provides access to device configuration parameters and ranges, and options for device and I/O setup. The advanced maintenance, engineering, and the HMI configuration tabs can be reached from the Advanced Properties Display. This tab is used for initial system commissioning or later system changes.

### Advanced Maintenance Tab



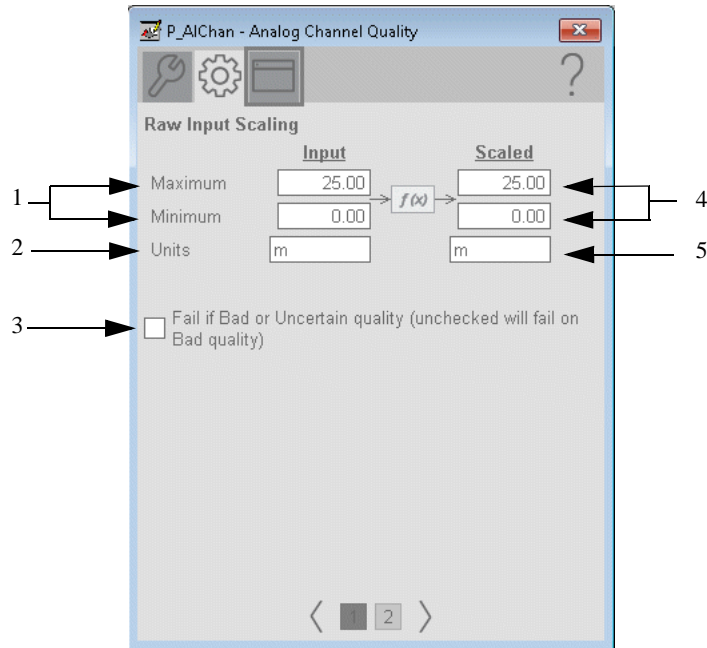
**Table 68 - Advanced Maintenance Tab Description**

Item	Description
1	Type the value to output as the process variable when a condition occurs that has its action set to 'Replace'.
2	Type the amount of time the input must stay within the range thresholds (with deadband) to clear the Out of Range (fail) condition. The off-delay time is used to help prevent a chattering fail detection on a noisy signal near a range threshold.
3	Type the amount of time the input must stay beyond a range threshold to cause an Out of Range (fail) condition. The on-delay time is used to avoid an unnecessary fail detection when the input only momentarily exceeds the threshold.
4	Type the amount of time the input must remain unchanged to trigger a stuck input condition. A value of zero means the input must change every instruction scan to avoid a stuck input condition. Type a large value to disable stuck input detection.



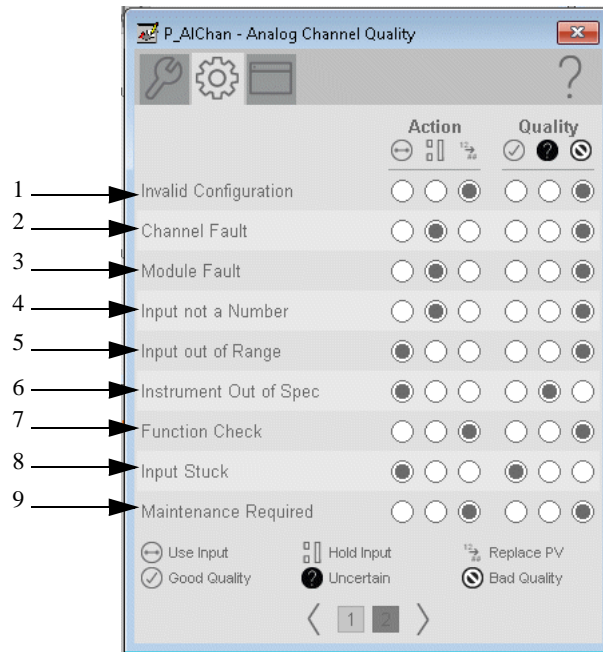
## Engineering Tab

The engineering tab is divided into two pages. On this tab, configure the Process Variable quality settings.



**Table 69 - Engineering Tab Page 1 Description**

Item	Description
1	Type the Raw Value range of the input signal that is connected to Inp_PV. The Raw minimum default is 0.0 and the Raw maximum is 100.0. The Raw Min/Max and Process Variable engineering units Min/Max are used for scaling to engineering units.
2	Type the units of measure for the input signal. "mA DC" is the default.
3	Check to trigger a failure condition and alarm when the Process Variable status is either Bad or Uncertain. Clear this checkbox to trigger the failure condition when only the Process Variable status is Bad.
4	Type the Process Variable range of the input signal that is connected to Inp_PV. The Process Variable engineering units minimum default is 0.0 and the Process Variable engineering units maximum is 100.0. <b>EXAMPLE:</b> If your input card provides a signal from 4...20 mA that represents -50...+250 °C, set Cfg_PVEUMin to -50.0 and Cfg_PVEUMax to 250.0. The Raw Min/Max and Process Variable engineering units Min/Max are used for scaling to engineering units.
5	Type the engineering units for display on the HMI. Percent (%) is the default.



**Table 70 - Engineering Tab Page 2 Description**

Item	Description
1	<p>Action:</p> <p>When the P_AIChan configuration is not valid:</p> <ul style="list-style-type: none"> <li>• Use the input to determine value</li> <li>• Hold value at its last good value</li> <li>• Set value by using Cfg_PVReplaceVal</li> </ul> <p>Quality:</p> <p>When the P_ configuration is not valid:</p> <ul style="list-style-type: none"> <li>• Set Sts_PVGood</li> <li>• Set Sts_PVUncertain</li> <li>• Set Sts_PVBad</li> </ul>
2	<p>Action:</p> <p>When there is a channel fault:</p> <ul style="list-style-type: none"> <li>• Use the input to determine value</li> <li>• Hold value at its last good value</li> <li>• Set value by using Cfg_PVReplaceVal</li> </ul> <p>Quality:</p> <p>When there is a channel fault:</p> <ul style="list-style-type: none"> <li>• Set Sts_PVGood</li> <li>• Set Sts_PVUncertain</li> <li>• Set Sts_PVBad</li> </ul>

**Table 70 - Engineering Tab Page 2 Description**

Item	Description
3	<p>Action:</p> <p>When there is a module fault:</p> <ul style="list-style-type: none"> <li>• Use the input to determine value</li> <li>• Hold value at its last good value</li> <li>• Set value by using Cfg_PVReplaceVal</li> </ul> <p>Quality:</p> <p>When there is a module fault:</p> <ul style="list-style-type: none"> <li>• Set Sts_PVGood</li> <li>• Set Sts_PVUncertain</li> <li>• Set Sts_PVBad</li> </ul>
4	<p>Action:</p> <p>When the input is not a number:</p> <ul style="list-style-type: none"> <li>• Use the input to determine value</li> <li>• Hold value at its last good value</li> <li>• Set value by using Cfg_PVReplaceVal</li> </ul> <p>Quality:</p> <p>When the input is not a number:</p> <ul style="list-style-type: none"> <li>• Set Sts_PVGood</li> <li>• Set Sts_PVUncertain</li> <li>• Set Sts_PVBad</li> </ul>
5	<p>Action:</p> <p>When the input is out of range:</p> <ul style="list-style-type: none"> <li>• Use the input to determine value</li> <li>• Hold value at its last good value</li> <li>• Set value by using Cfg_PVReplaceVal</li> </ul> <p>Quality:</p> <p>When the input is out of range:</p> <ul style="list-style-type: none"> <li>• Set Sts_PVGood</li> <li>• Set Sts_PVUncertain</li> <li>• Set Sts_PVBad</li> </ul>
6	<p>Action:</p> <ul style="list-style-type: none"> <li>• Use the input to determine value</li> <li>• Hold value at its last good value</li> </ul> <p>Set value by using Cfg_PVReplaceVal</p> <p>Quality:</p> <p>When the input is out of spec:</p> <ul style="list-style-type: none"> <li>• Set Sts_PVGood</li> <li>• Set Sts_PVUncertain</li> <li>• Set Sts_PVBad</li> </ul>
7	<p>Action:</p> <p>When Inp_FuncCheck is set:</p> <ul style="list-style-type: none"> <li>• Use the input to determine value</li> <li>• Hold value at its last good value</li> <li>• Set value by using Cfg_PVReplaceVal</li> </ul> <p>Quality:</p> <p>When Inp_FuncCheck is set:</p> <ul style="list-style-type: none"> <li>• Set Sts_PVGood</li> <li>• Set Sts_PVUncertain</li> <li>• Set Sts_PVBad</li> </ul>

**Table 70 - Engineering Tab Page 2 Description**

Item	Description
8	Action: When the input is stuck (no change): <ul style="list-style-type: none"> <li>• Use the input to determine value</li> <li>• Hold value at its last good value</li> <li>• Set value by using Cfg_PVReplaceVal</li> </ul> Quality: When the input is stuck (no change): <ul style="list-style-type: none"> <li>• Set Sts_PVGood</li> <li>• Set Sts_PVUncertain</li> <li>• Set Sts_PVBad</li> </ul>
9	Action: When Inp_MaintReqd is set: <ul style="list-style-type: none"> <li>• Use the input to determine value</li> <li>• Hold value at its last good value</li> <li>• Set value by using Cfg_PVReplaceVal</li> </ul> Quality: When Inp_MaintReqd is set: <ul style="list-style-type: none"> <li>• Set Sts_PVGood</li> <li>• Set Sts_PVUncertain</li> <li>• Set Sts_PVBad</li> </ul>

### *HMI Configuration Tab*

Configure the description, label, tag, and security area for the device.

The HMI configuration tab provides access to displayed text, and faceplate-to-faceplate navigation settings. Configure the description, label, tag, and security area for the device. See [Basic Faceplate Attributes on page 32](#) for the description of the common attributes.

### **Alarms Tab**

The Alarms tab displays each configured alarm. The icon on the tab for the alarms page changes color to show the current active alarm status. A blinking alarm icon indicates that one or more alarms must be acknowledged or the device must be reset. See [Common Alarm Block \(P\\_Alarm\) on page 66](#) for more information.

## Dual Sensor Analog Input (P\_AInDual)

The P\_AInDual (Dual Analog Input) Add-On Instruction monitors one analog Process Variable by using two analog input signals (dual sensors, dual transmitters, and dual-input channels). The Add-On Instruction has the same basic features as P\_AIn. See [Basic Analog Input \(P\\_AIn\) on page 94](#).

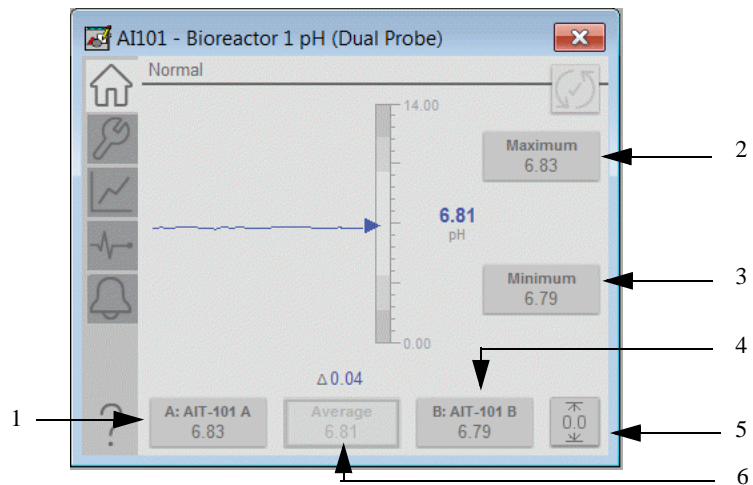
This document is for the visualization files, display elements, global objects, and HMI information. The operation of the Add-on Instructions and controller code is contained in publication [PROCES-RM013](#).

### Display Elements

Dual Sensor Analog Input (P\_AInDual) uses the same display elements a P\_AIn. See [Basic Analog Input \(P\\_AIn\) on page 94](#) for the display elements.

### Operator Tab

The Faceplate initially opens to the Operator (Home) tab. From here, an operator can monitor the device status and manually operate the device when it is in Operator command source.

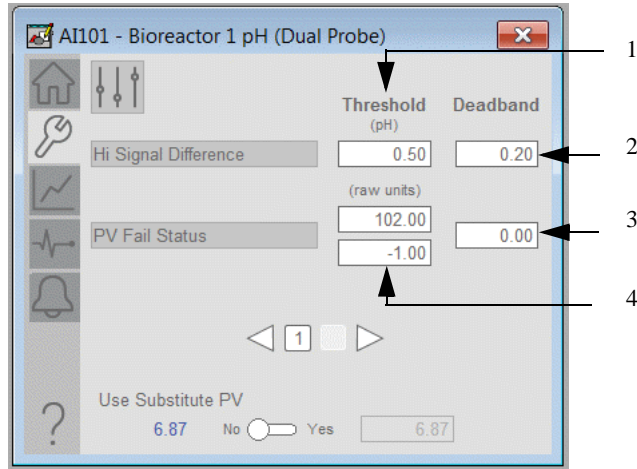


**Table 71 - Operator Tab Description**

Item	Description
1	Click to select Sensor A Input Process Variable.
2	Click to select the maximum of Sensor A and Sensor B Input Process Variable.
3	Click to select the minimum of Sensor A and Sensor B Input Process Variable.
4	Click to select Sensor B Input Process Variable.
5	Clear the minimum / maximum extents of the capture.
6	Click to select the average of Sensor A and Sensor B input Process Variables.

## Maintenance Tab

Maintenance personnel use the information and controls on the Maintenance tab to adjust device parameters, troubleshoot and temporarily work around device problems. The maintenance tab for the P\_AInDual Add-On Instruction has two pages. The first page contains the threshold and deadband information for the high and low limits and is the same as the P\_AIn Add-On Instruction. See [Basic Analog Input \(P\\_AIn\) on page 94](#). Additional information for this instruction on page 2 can be seen in the following diagram.



**Table 72 - Maintenance Tab Description**

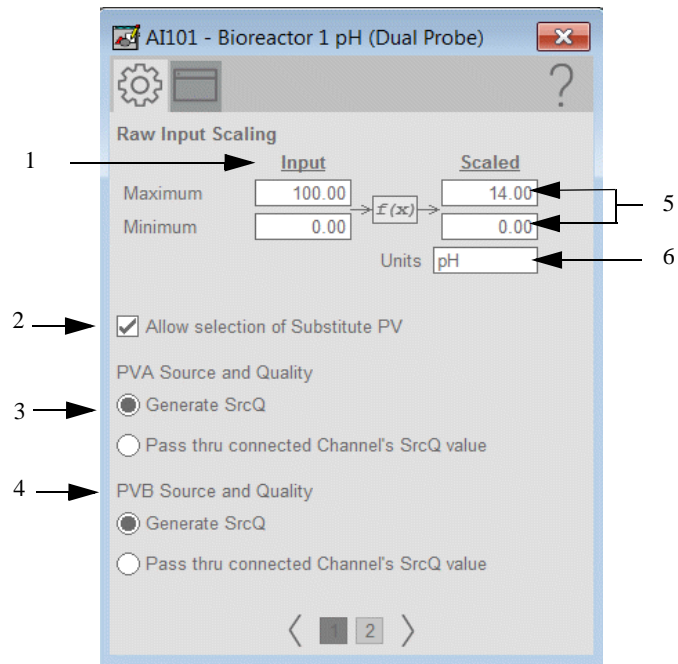
Item	Description
1	Process variable high/low signal difference threshold. Type the threshold (trip point) for analog input alarms.
2	Process variable deadband. Type the deadband (hysteresis) that is applied to the alarm limit. Deadband helps prevent a noisy signal from generating numerous spurious alarms. <b>Example:</b> If the High alarm limit is 90.0 and the High alarm deadband is 5, once the signal rises above 90.0 and generates a High alarm. The signal must fall below 85.0 (90.0 minus 5.0) for the alarm to clear.
3	Process variable fail deadband. Type the deadband (hysteresis) that is applied to each alarm limit. Deadband helps prevent a noisy signal from generating numerous spurious alarms. <b>Example:</b> If the High alarm limit is 90.0 and the High alarm deadband is 5, once the signal rises above 90.0 and generates a High alarm. The signal must fall below 85.0 (90.0 minus 5.0) for the alarm to clear.
4	Process variable high/low fail threshold in raw units.

## Advanced Properties Display

The Advanced Properties Display provides access to device configuration parameters and ranges, and options for device and I/O setup. The engineering tab and the HMI configuration tab can be reached from the Advanced Properties Display. This tab is used for initial system commissioning or later system changes.

### Engineering Tab

Use the engineering tab to configure the Process Variable unit for the device.



**Table 73 - Engineering Tab Page 1 Description**

Item	Description
1	<p>Input (unscaled) minimum and maximum</p> <p>These parameters must be set to the range of the signal that is connected to the Inp_Process Variable Input. The raw minimum default is 0.0 and the raw maximum default is 100.0.</p> <p><b>Example:</b> If your input card provides a signal from 4.0...20.0mA, set Cfg_InpRawMin to 4.0 and Cfg_InpRawMax to 20.0. The raw minimum/maximum and engineering units minimum/maximum are used for scaling to engineering units.</p>
2	<p>Check to allow the Substitute Process Variable Maintenance function.</p> <p>Clear this checkbox to disallow the Substitute Process Variable Maintenance function (default).</p>
3	<p>PV Source and Quality Input A</p> <p><b>Generate SrcQ:</b> This instruction determines the Process Variable quality using Inp_PVBad, Inp_PVUncertain, and the PV value (out of range, infinite or not a number)</p> <p><b>Pass thru connected Channel's SrcQ value:</b> This instruction uses the Source and Quality (SrcQ) value that is provided by an upstream object (such as P_AIChan) via Inp_PVSrcQ to determine the PV source and quality.</p>

Item	Description
4	<p>PV Source and Quality Input B</p> <p><b>Generate SrcQ:</b> This instruction determines the Process Variable quality using Inp_PVBad, Inp_PVUncertain, and the PV value (out of range, infinite or not a number)</p> <p><b>Pass thru connected Channel's SrcQ value:</b> This instruction uses the Source and Quality (SrcQ) value that is provided by an upstream object (such as P_AIChan) via Inp_PVSrcQ to determine the PV source and quality.</p>
5	<p>EU minimum and maximum for scaling</p> <p>These parameters must be set to match the Process Variable range of the input signal that is connected to Inp_PV. The Process Variable engineering units minimum default is 0.0 and the Process Variable engineering units maximum is 100.0.</p> <p><b>Example:</b> If your input card provides a signal from 4...20 mA that represents -50...+250 °C, set Cfg_PVEUMIN to -50.0 and Cfg_PVEU maximum to 250.0.</p> <p>The raw minimum/maximum and Process Variable engineering units minimum/maximum are used for scaling to engineering units.</p>
6	Type engineering units for display on the HMI.

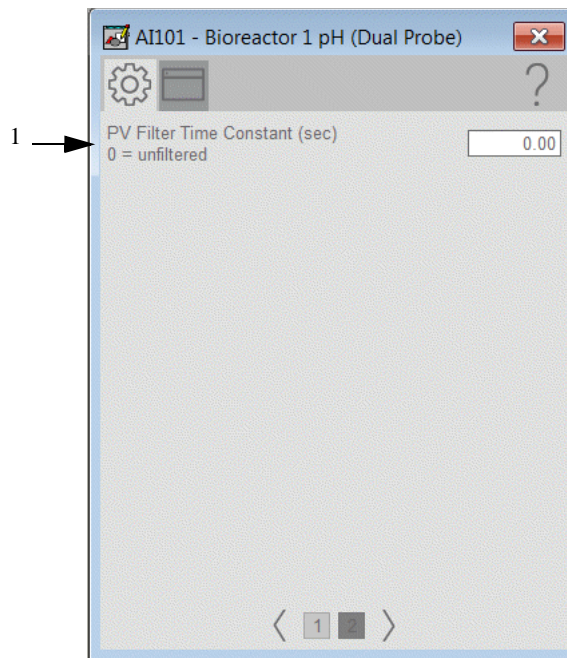


Table 74 - Engineering Tab Page 1 Description

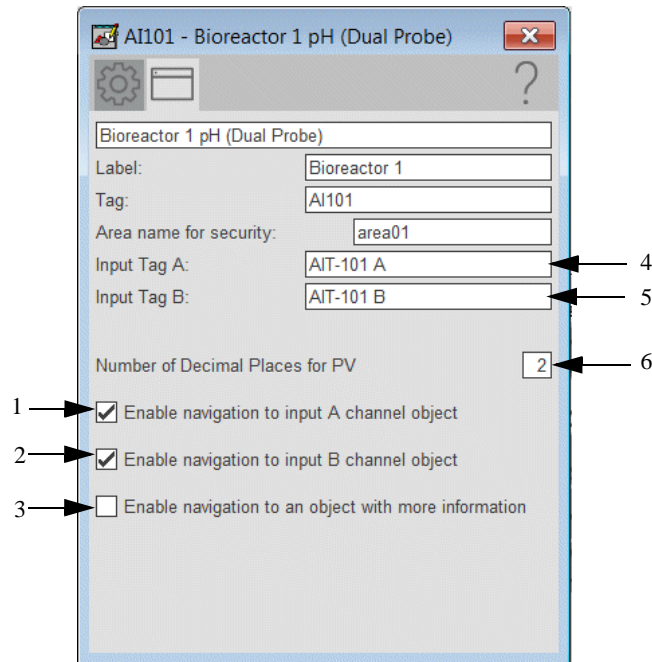
Item	Description
1	Type the time in seconds for the process variable filter time constant.



## HMI Configuration Tab

Configure the description, label, tag, and security area for the device.

See [Basic Faceplate Attributes on page 32](#) for the description of the common attributes.



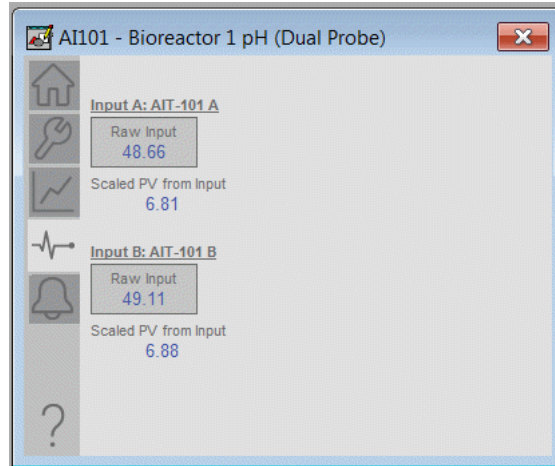
**Table 75 - HMI Configuration Description**

Item	Description
1	Check to enable navigation to an upstream channel object (for example, P_AIChan). <b>IMPORTANT:</b> The name of the Channel object in the controller must be the name of the object with the suffix '_ChanA'. For example, if your P_AInDual object has the name 'AInDual123', then its Channel object must be named 'AInDual123_ChanA'.
2	Check to enable navigation to an upstream channel object (for example, P_AIChan). <b>IMPORTANT:</b> The name of the Channel object in the controller must be the name of the object with the suffix '_ChanB'. For example, if your P_AInDual object has the name 'AInDual123', then its Channel object must be named 'AInDual123_ChanB'.
3	Check to enable navigation to an object with more information (Cfg_HasMoreObj is set to true.) This can be configured to navigate to an AOI backing tag or a UDT tag that has HMI_Type and HMI_Lib defined. For example, there is a motor with the tag name P_101 and there is a need to have the more information button navigate to the parent P_LLS object. A tag is created for the P_LLS object that is given the alias P101_More. When the more information button is pressed on the motor, it links to P101_More. This will open the faceplate for the LLS object.
4	Type the name for Input Tag A to show on the faceplate and Tooltip. <b>IMPORTANT:</b> Pause the mouse over the field to display a tool tip with the configured Logix tag/path.

<b>Item</b>	<b>Description</b>
5	Type the name for Input Tag B to show on the faceplate and Tooltip. <b>IMPORTANT:</b> Pause the mouse over the field to display a tool tip with the configured Logix tag/path.
6	Set the number of decimal places for the Process Variable.

## Diagnostics Tab

The Diagnostic tab provides indications to diagnose device problems. This tab includes specific reasons a device is 'Not Ready', device warnings and faults, warning and fault history, and predictive/preventive maintenance data. The initial faceplate shows the raw input process variable.



Click the raw input button to open the analog channel quality faceplate. This tab provides an overview of the process variable. For more information on the analog channel faceplate, See [Analog Input Channel \(P\\_AIChan\) on page 110](#).

## Alarms Tab

The Alarms tab displays each configured alarm. The icon on the tab for the alarms page changes color to show the current active alarm status. A blinking alarm icon indicates that one or more alarms must be acknowledged or the device must be reset. See [Common Alarm Block \(P\\_Alarm\) on page 66](#) for more information.

## Multiple Analog Input (P\_AInMulti)

The P\_AInMulti (Multiple Analog Input) Add-On Instruction monitors one analog process variable (Process Variable) by using up to eight analog input signals (sensors, transmitters, input channels). The Add-On Instruction has the same basic features as P\_AIn. See [Basic Analog Input \(P\\_AIn\) on page 94](#).

This document is for the visualization files, display elements, global objects, and HMI information. The operation of the Add-on Instructions and controller code is contained in publication [PROCES-RM013](#).

### Display Elements

A display element (global object) is created once and can be referenced multiple times on multiple displays in an application. When changes are made to the original (base) object, the instantiated copies (reference objects) are automatically updated. Use of global objects, with tag structures in the ControlLogix system, aid consistency and save engineering time.

**Table 76 - P\_AInMulti Display Elements Description**

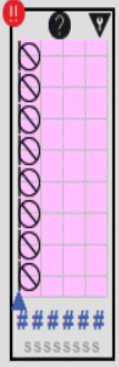
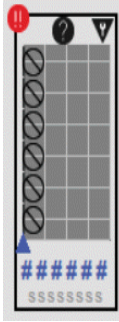
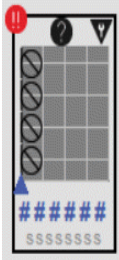

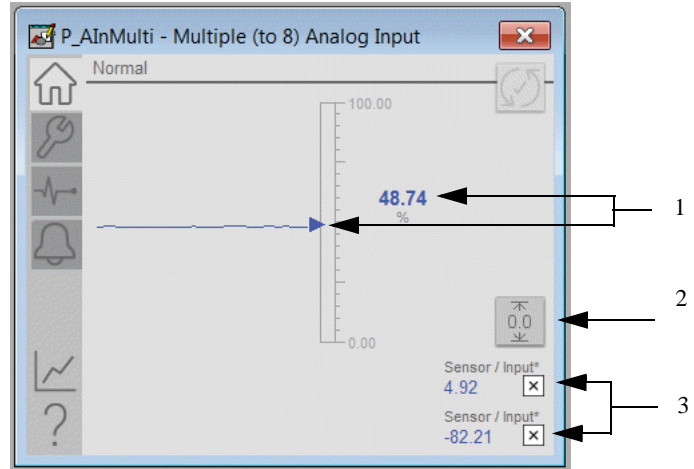
Display Element Name	Display Element	Description
GO_P_AInMulti_8V		The object displays eight inputs (A-H), with each input a moving line on a horizontal axis. The graphic display includes indicators for disabled and rejected inputs.
GO_P_AInMulti_6V		The object displays six inputs (A-F), with each input a moving line on a horizontal axis. The graphic display includes indicators for disabled and rejected inputs.
GO_P_AInMulti_4V		The object displays four inputs (A-D), with each input a moving line on a horizontal axis. The graphic display includes indicators for disabled and rejected inputs.

Table 76 - P\_AInMulti Display Elements Description

Display Element Name	Display Element	Description
GO_P_AInMulti_8H		The object displays eight inputs (A-H), with each input a moving line on a vertical axis. The graphic display includes indicators for disabled and rejected inputs.

## Operator Tab

The Faceplate initially opens to the Operator (Home) tab. From here, an operator can monitor the device status and manually operate the device when it is in Operator command source.

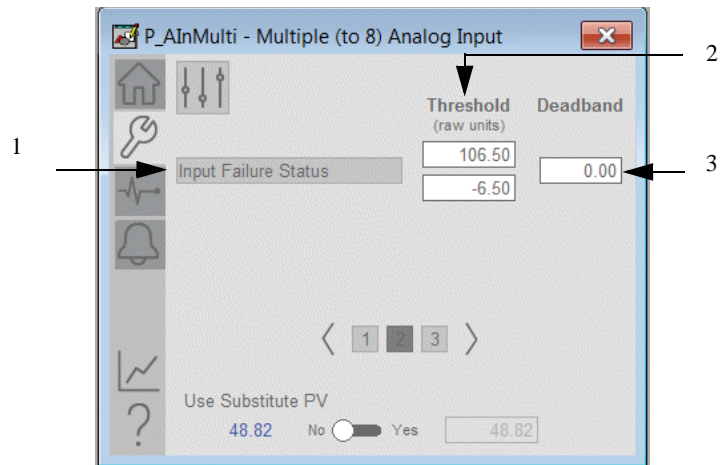


**Table 77 - Operator Tab Description**

Item	Description
1	Process Variable
2	Clear minimum/maximum extents of the capture
3	Display of the input signals that are being rejected.

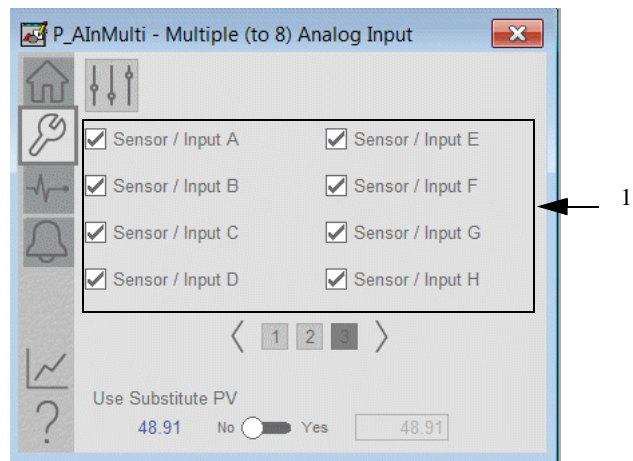
## Maintenance Tab

Maintenance personnel use the information and controls on the Maintenance tab to adjust device parameters, troubleshoot and temporarily work around device problems. The maintenance tab for the P\_AInMulti Add-On Instruction has three pages. The first page contains the threshold and deadband information for the high and low limits and is the same as the P\_AIn Add-On Instruction. See [Basic Analog Input \(P\\_AIn\) on page 94](#). Additional information for this instruction on page 2 and three can be seen in the following diagram.



**Table 78 - Maintenance Tab Page 1 Description**

Item	Description
1	Click a threshold name to open the associated P_Gate faceplate.
2	Input failure status high/low threshold.
3	Type the deadband (hysteresis) that is applied to each alarm limit. Deadband helps prevent a noisy signal from generating numerous spurious alarms. <b>EXAMPLE:</b> If the High Alarm Limit is 90.0 and the High Alarm deadband is 5, once the signal rises above 90.0 and generates a High Alarm. The signal must fall below 85.0 (90.0 minus 5.0) for the alarm to clear.



**Table 79 - Maintenance Tab Page 2 Description**

Item	Description
1	<p>Sensor inputs. Check:</p> <ul style="list-style-type: none"> <li>• ON if the corresponding input is to be used to calculate the final Process Variable (average or median).</li> <li>• OFF to exclude the corresponding input from the Process Variable calculation.</li> </ul> <p>This configuration is typically used to exclude a particular input when it is taken out of service for maintenance. If the P_InMulti instruction <b>has</b> a Process Variable but is <b>not using</b> it, the Maintenance Bypass Indicator is displayed.</p>

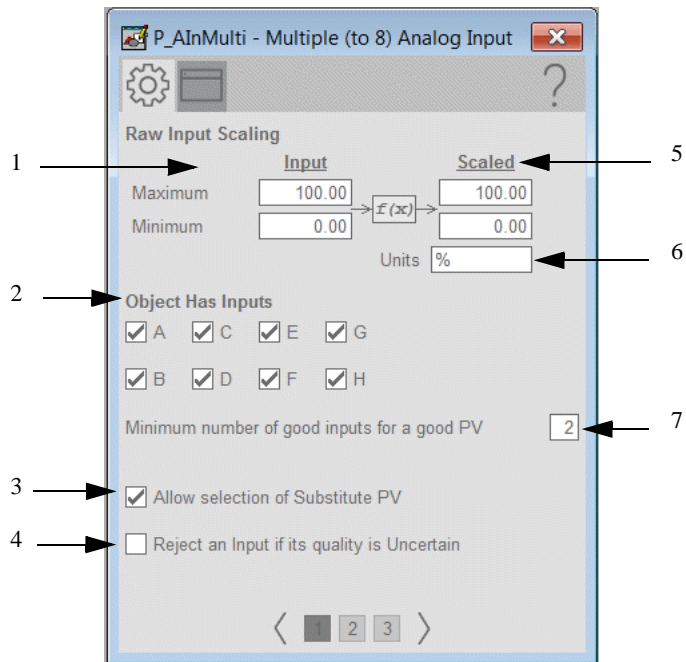


## Advanced Properties Display

The Advanced Properties Display provides access to device configuration parameters and ranges, and options for device and I/O setup. The engineering tab and the HMI configuration tab can be reached from the Advanced Properties Display. This tab is used for initial system commissioning or later system changes.

### Engineering Tab

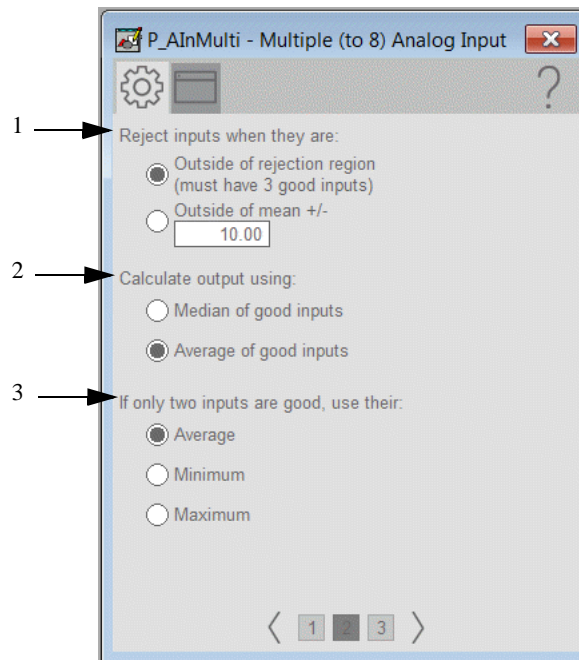
The engineering tab is divided into three pages.



**Table 80 - Engineering Tab Page 1 Description**

Item	Description
1	Enter these parameters within the range of the signal that is connected to the Inp_PV Input. The Raw Min default is 0.0 and the Raw Max default is 100.0. <b>EXAMPLE:</b> If your input card provides a signal from 4.0...20.0mA, set Cfg_InpRawMin to 4.0 and Cfg_InpRawMax to 20.0. The Raw minimum/maximum and engineering units minimum/maximum are used for scaling to engineering units.
2	Check to set this parameter: <ul style="list-style-type: none"> <li>ON, if the corresponding Process Variable Input is to be used to calculate final Process Variable (average or median)</li> <li>OFF, to exclude the corresponding Process Variable Input from the Process Variable calculation</li> </ul> <b>TIP:</b> This configuration determines whether a particular input is intended to be wired and used. See the Maintenance tab for functions to take an input out of service for maintenance temporarily.
3	Check to set this parameter to one of the following: <ul style="list-style-type: none"> <li>OFF to allow the Substitute Process Variable Maintenance function (default).</li> <li>ON to disallow the Substitute Process Variable Maintenance function.</li> </ul>

Item	Description
4	<p>Check to set this parameter to one of the following:</p> <ul style="list-style-type: none"> <li>• ON, an input that is flagged as uncertain is rejected and not used to calculate the final Process Variable.</li> <li>• OFF, an input that is flagged as uncertain is not rejected and is still used to calculate the final Process Variable. The flag causes the final Process Variable to be flagged as uncertain (default).</li> </ul>
5	<p>Enter these parameters within the Process Variable range of the input signal that is connected to Inp_PVA and Inp_PVB. The Process Variable engineering units minimum default is 0.0 and the Process Variable engineering units maximum is 100.0.</p> <p><b>EXAMPLE:</b> If your input card provides a signal from 4...20 mA that represents -50...+250 °C, set Cfg_PVEUMIN to -50.0 and Cfg_PVEUMax to 250.0.</p> <p>The Raw Min/Max and Process Variable engineering units Min/Max are used for scaling to engineering Units.</p>
6	Enter the engineering units for display on the HMI. Percent (%) is the default.
7	Type the number of unrejected Process Variable inputs that are required to have the final Process Variable value show good quality.



**Table 81 - Engineering Tab Page 2 Description**

Item	Description
1	<p>Click:</p> <ul style="list-style-type: none"> <li>• 'Outside of rejection region' to reject an input that is more than two standard deviations from the mean.</li> <li>• 'Outside of mean +/-' to reject an input that deviates from the mean by more than the value entered. Value is in PV engineering units.</li> </ul> <p><b>IMPORTANT:</b> At least four inputs must be used for the 'Outside of rejection region' selection to be meaningful.</p>

Item	Description
2	<p>Click:</p> <ul style="list-style-type: none"> <li>'Average of good inputs' - the calculated final Process Variable is the average (arithmetic mean) of the good (non-rejected) Process Variable inputs.</li> <li>'Median of good inputs' - the calculated final Process Variable is the median (central value) of the good (non-rejected) Process Variable inputs (default). The average is the sum of values that are divided by the number of values. The median is the value of the item in the middle. If there are an even number of items, the median is the average of the two central values.</li> </ul>
3	Click one of the options to determine the output calculation when there are only two unrejected inputs.

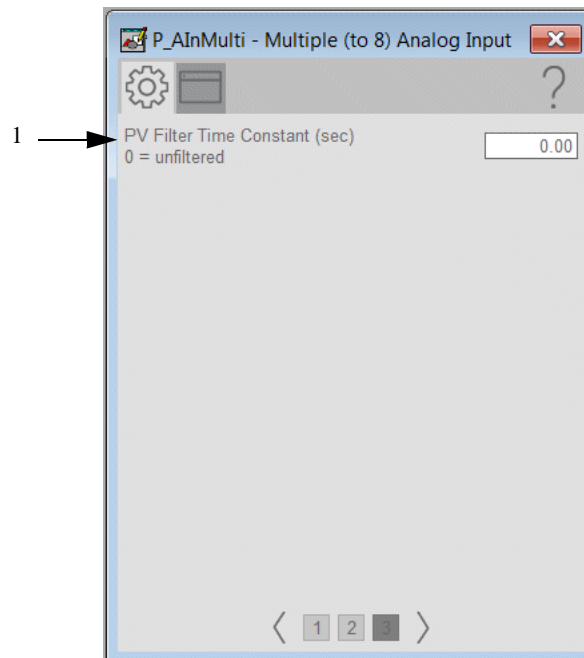
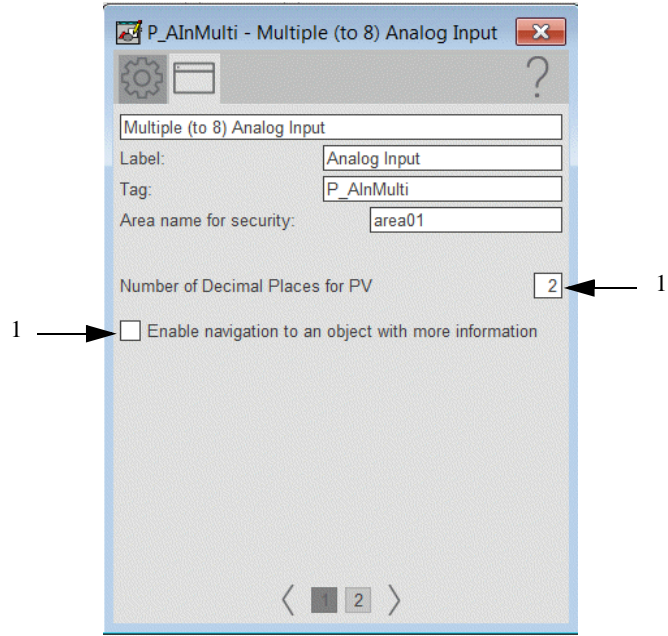


Table 82 - Engineering Tab Page 3 Description

Item	Description
1	This parameter sets the filter time constant for the first-order (lag) filter applied to the Process Variable. The filter is applied after scaling and before alarm checking and Process Variable display as Val.

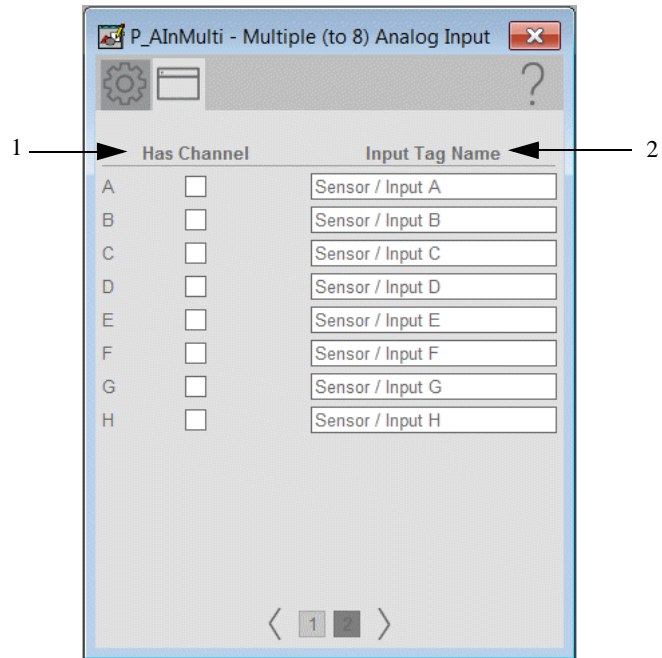
### HMI Configuration Tab

Configure the description, label, tag, and security area for the device. See [Basic Faceplate Attributes on page 32](#) for the description of the common attributes. The HMI Configuration has two tabs for this object.



**Table 83 - HMI Configuration Page 1 Description**

Item	Description
1	<p>Check to enable navigation to an object with more information (Cfg_HasMoreObj is set to true.)</p> <p>This can be configured to navigate to an AOI backing tag or a UDT tag that has HMI_Type and HMI_Lib defined.</p> <p>For example, there is a motor with the tag name P_101 and there is a need to have the more information button navigate to the parent P_LLS object. A tag is created for the P_LLS object that is given the alias P101_More. When the more information button is pressed on the motor, it links to P101_More. This will open the faceplate for the LLS object.</p>
2	Type the number of decimal places to show for the Process Variable.

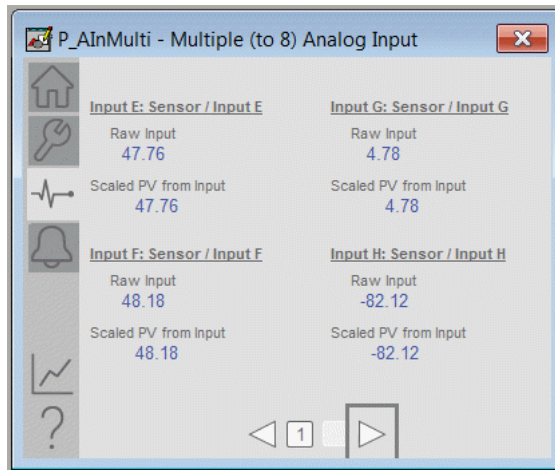
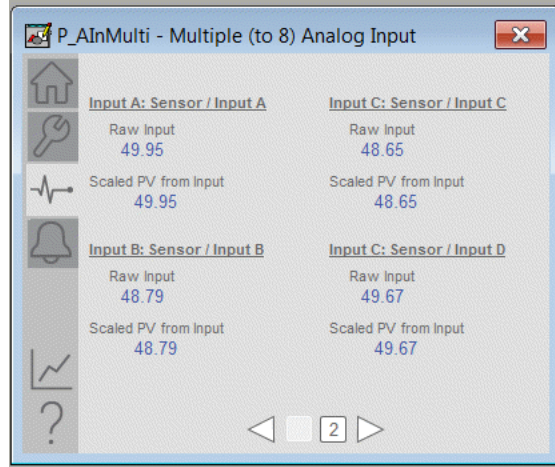


**Table 84 - HMI Configuration Page 2 Description**

Item	Description
1	<p>Check to enable navigation to an upstream channel object (for example, P_AIChan).</p> <p><b>IMPORTANT:</b> The name of the Channel object in the controller must be the name of the object with the suffix ‘_Chan’ plus the input letter (A...H). This restriction applies to each of the eight channels (A...H). For example, if your P_AIInMulti object has the name ‘AIInMulti123’, then its Channel A object must be named ‘AIInMulti123_ChanA’.</p>
2	Set the number of decimal places for the Process Variable.

## Diagnostics Tab

The Diagnostic tab provides raw input process variables and the scaled process variable from the inputs.



## Alarms Tab

The Alarms tab displays each configured alarm. The icon on the tab for the alarms page changes color to show the current active alarm status. A blinking alarm icon indicates that one or more alarms must be acknowledged or the device must be reset. See [Common Alarm Block \(P\\_Alarm\) on page 66](#) for more information.

## Discrete Input (P\_DIn)



The P\_DIn (Discrete Input) Add-On Instruction is used to receive and process one discrete condition (the Process Variable) typically for a channel of a discrete input card. It can be used with any discrete (BOOL) signal.

This document is for the visualization files, display elements, global objects, and HMI information. The operation of the Add-on Instructions and controller code is contained in publication [PROCES-RM013](#).

## Display Elements

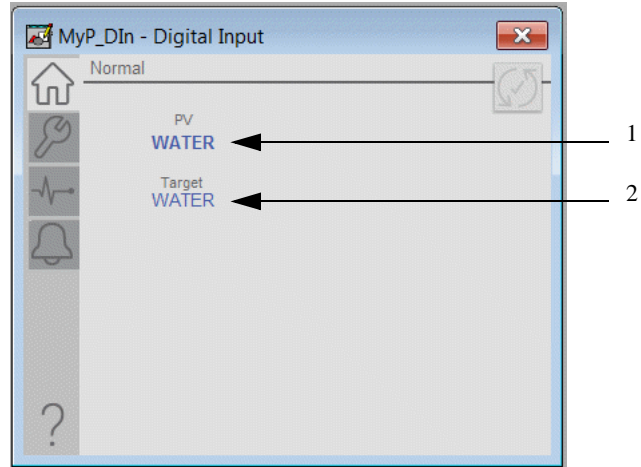
A display element (global object) is created once and can be referenced multiple times on multiple displays in an application. When changes are made to the original (base) object, the instantiated copies (reference objects) are automatically updated. Use of global objects, with tag structures in the ControlLogix system, aid consistency and save engineering time.

**Table 85 - P\_DIn Display Elements Description**

Display Element Name	Display Element	Description
GO_P_DIn		Global object with label.
GO_P_DIn1		Global object without label.

## Operator Tab

The Faceplate initially opens to the Operator (Home) tab. From here, an operator can monitor the device status and manually operate the device when it is in Operator command source.



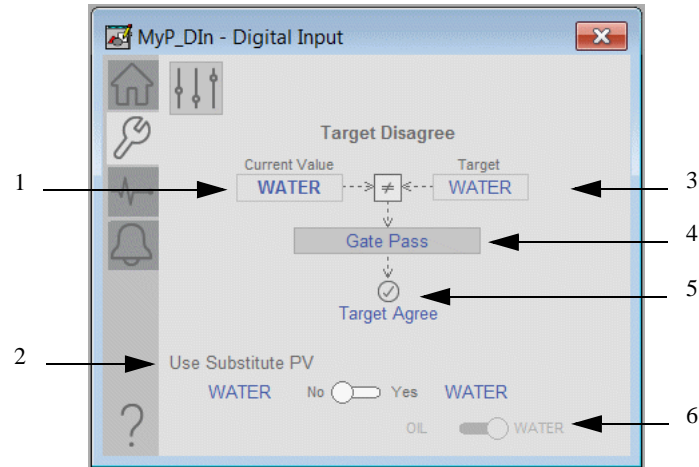
**Table 86 - Operator Tab Description**

Item	Description
1	Current Process Variable
2	Target Process Variable



## Maintenance Tab

Maintenance personnel use the information and controls on the Maintenance tab to adjust device parameters, troubleshoot, temporarily work around device problems, and disable the device for routine maintenance.

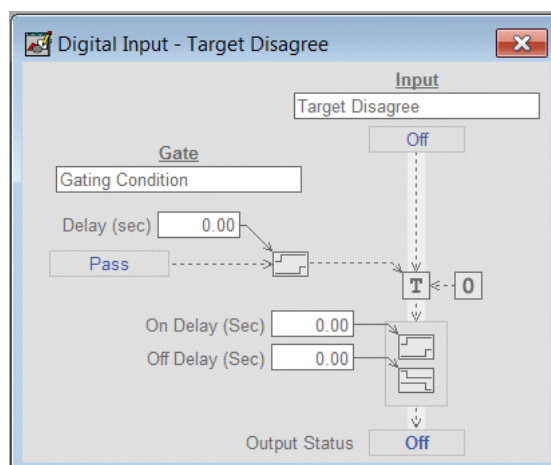


**Table 87 - Maintenance Tab Description**

Item	Description
1	Current Process Variable
2	Click to enable the use of the Substitute Process Variable.
3	Target Process Variable
4	Gate condition
5	Target status
6	Click to choose Process Variable to be used.

Click Gate Condition to open the P\_Gate faceplate. From the P\_Gate faceplate, you can configure and perform additional operations for each alarm, including Gate Delay, Status On-delay, Status Off-delay, and condition text.

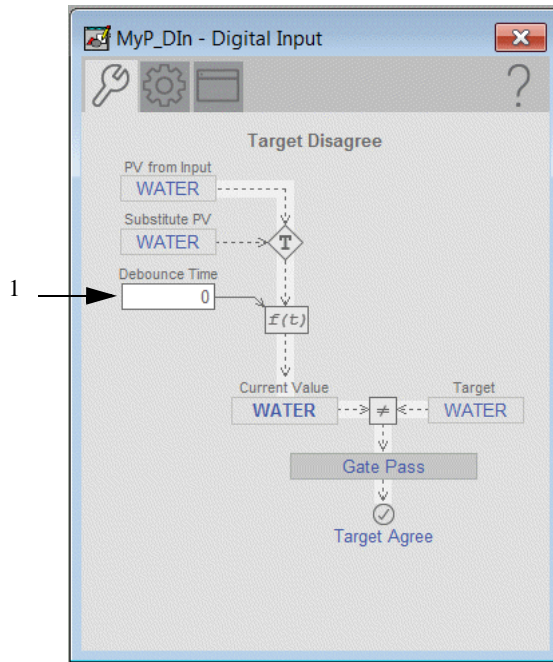
See [Condition Gate Delay \(P\\_Gate\) on page 43](#)



## Advanced Properties Display

The Advanced Properties Display provides access to device configuration parameters and ranges, and options for device and I/O setup. The Advanced Maintenance, Engineering, and HMI configuration tabs can be reached from the Advanced Properties Display. This tab is used for initial system commissioning or later system changes.

### Advanced Maintenance Tab

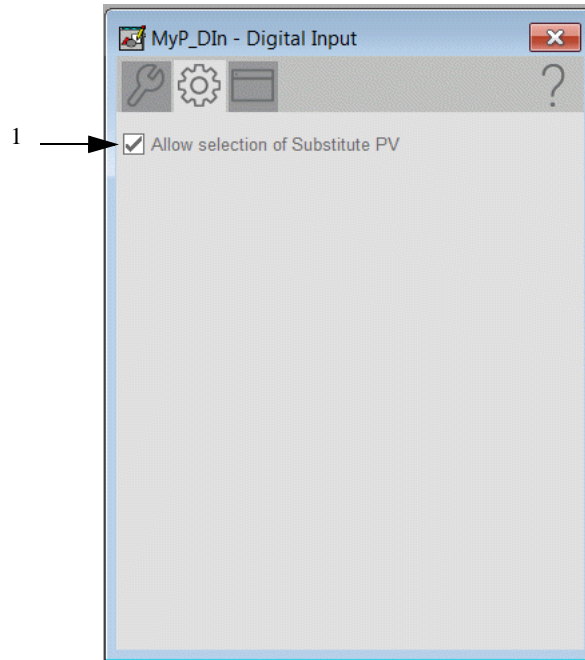


**Table 88 - Advanced Maintenance Tab Description**

Item	Description
1	Minimum time the Process Variable must maintain the state, in seconds.

### *Engineering Tab*

The engineering tab provides access to device configuration parameters and ranges, options for device and I/O setup, displayed text, and faceplate-to-faceplate navigation settings, for initial system commissioning or later system changes.

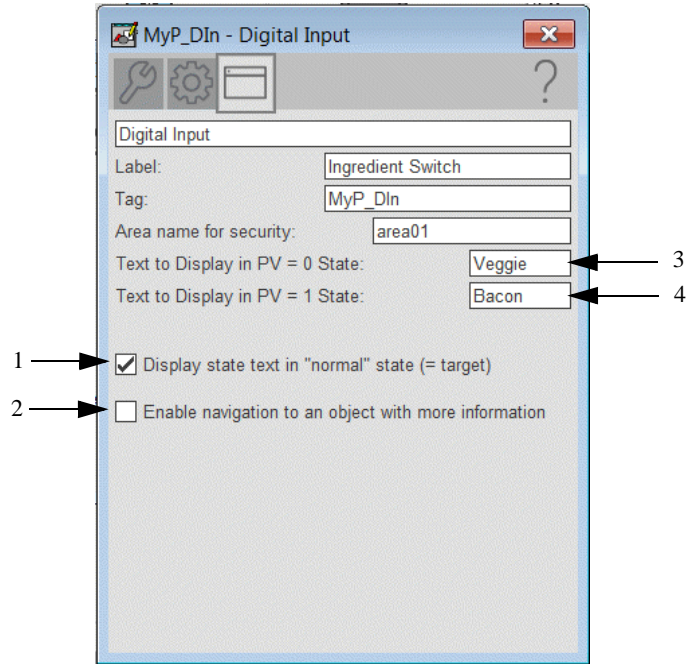


**Table 89 - Engineering Tab Description**

Item	Description
1	Check to enable the substitute Process Variable feature.

### HMI Configuration Tab

Configure the description, label, tag, and security area for the device. See [Basic Faceplate Attributes on page 32](#) for the description of the common attributes.



**Table 90 - HMI Configuration Description**

Item	Description
1	Check to display state text in normal state
2	Check to enable navigation to an object with more information (Cfg_HasMoreObj is set to true.) This can be configured to navigate to an AOI backing tag or a UDT tag that has HMI_Type and HMI_Lib defined. For example, there is a motor with the tag name P_101 and there is a need to have the more information button navigate to the parent P_LLS object. A tag is created for the P_LLS object that is given the alias P101_More. When the more information button is pressed on the motor, it links to P101_More. This will open the faceplate for the LLS object.
3	Type text to display in PV 0 State.
4	Type text to display in PV 1 State.

### Alarms Tab

The Alarms tab displays each configured alarm. The icon on the tab for the alarms page changes color to show the current active alarm status. A blinking alarm icon indicates that one or more alarms must be acknowledged or the device must be reset. See [Common Alarm Block \(P\\_Alarm\) on page 66](#) for more information.

## Digital Input Advanced (P\_DInAdv)

The P\_DInAdv (Discrete Input Advanced) Add-On Instruction provides additional functionality from the P\_DIn Add-On Instruction. This Add-On Instruction can be configured to use warning and failure indicators as well as identifying the equipment as a speed switch.



P\_DInAdv is used to receive and process one discrete condition (the Process Variable) typically for a channel of a discrete input card. It can be used with any discrete (BOOL) signal.

This document is for the visualization files, display elements, global objects, and HMI information. The operation of the Add-on Instructions and controller code is contained in publication [PROCES-RM013](#).

## Display Elements

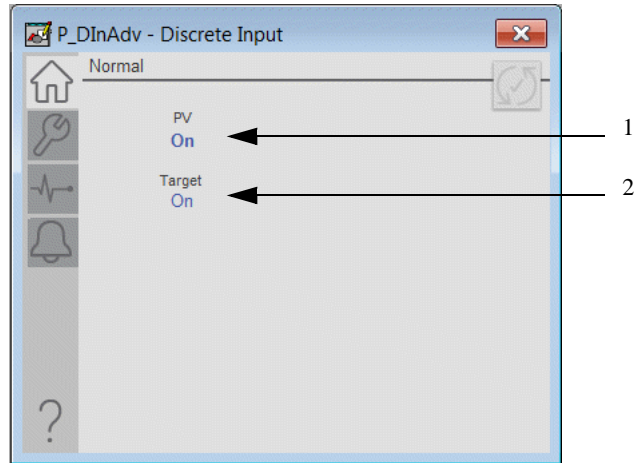
A display element (global object) is created once and can be referenced multiple times on multiple displays in an application. When changes are made to the original (base) object, the instantiated copies (reference objects) are automatically updated. Use of global objects, with tag structures in the ControlLogix system, aid consistency and save engineering time. This Add-On Instruction uses the same global objects as the P\_DIn Add-On Instruction.

**Table 91 - P\_DInAdv Display Elements Description**

Display Element Name	Display Element	Description
GO_P_DIn		Global object with label.
GO_P_DIn1		Global object without label.

## Operator Tab

The Faceplate initially opens to the Operator (Home) tab. From here, an operator can monitor the device status and manually operate the device when it is in Operator command source.

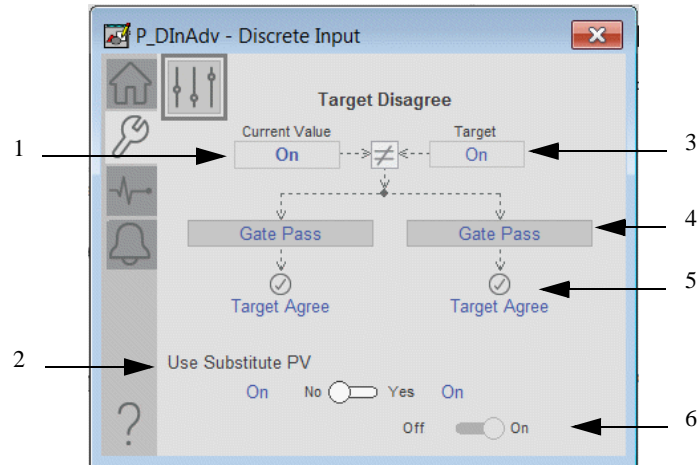


**Table 92 - Operator Tab Description**

Item	Description
1	Current Process Variable
2	Target Process Variable

## Maintenance Tab

Maintenance personnel use the information and controls on the Maintenance tab to adjust device parameters, troubleshoot, temporarily work around device problems, and disable the device for routine maintenance.



**Table 93 - Maintenance Tab Description**

Item	Description
1	Current Process Variable
2	Click to enable the use of the Substitute Process Variable.
3	Target Process Variable
4	Gate condition
5	Target status
6	Click to choose Process Variable to be used.

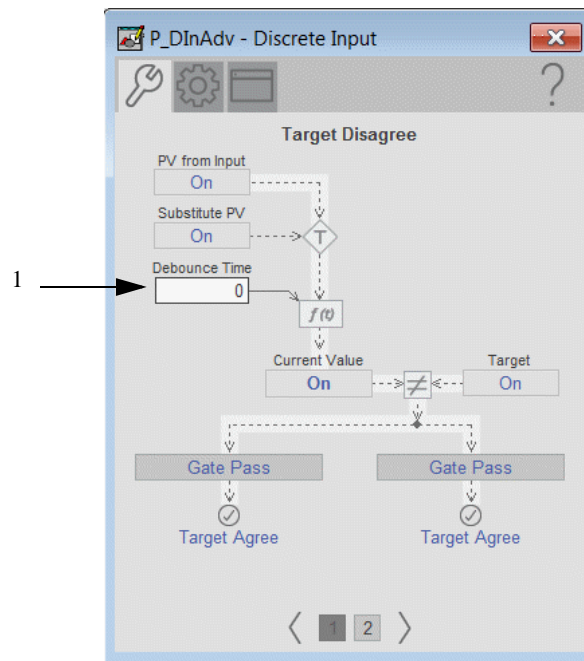
Click Gate Condition to open the P\_Gate faceplate. From the P\_Gate faceplate, you can configure and perform additional operations for each alarm, including Gate Delay, Status On-delay, Status Off-delay, and condition text.

See [Condition Gate Delay \(P\\_Gate\) on page 43](#)

## Advanced Properties Display

The Advanced Properties Display provides access to device configuration parameters and ranges, and options for device and I/O setup. The Advanced Maintenance, Engineering, and HMI configuration tabs can be reached from the Advanced Properties Display. This tab is used for initial system commissioning or later system changes.

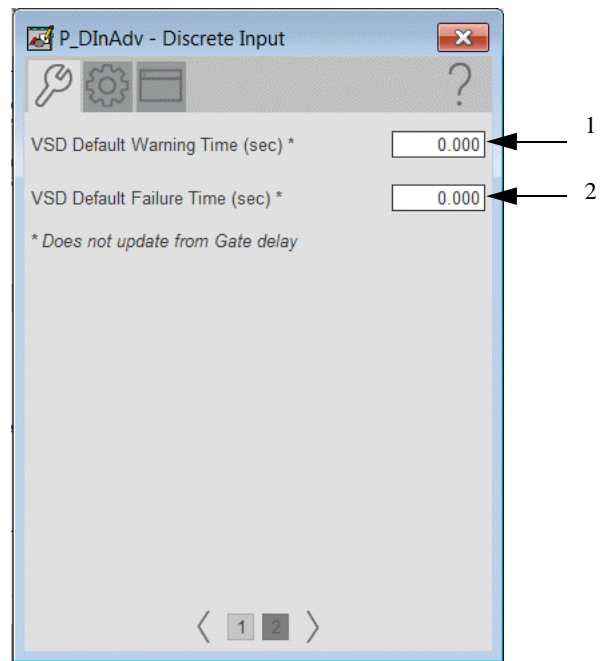
### Advanced Maintenance Tab



**Table 94 - Advanced Maintenance Tab Page 1 Description**

Item	Description
1	Minimum time the Process Variable must maintain the state, in seconds.

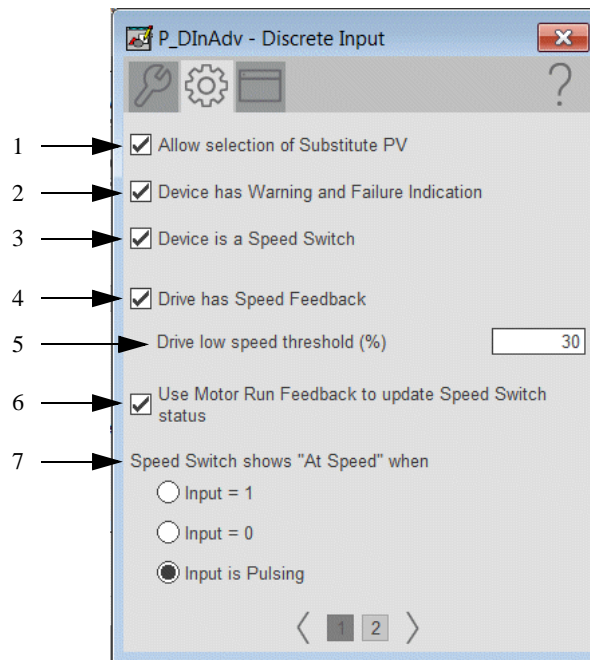


**Table 95 - Advanced Maintenance Tab Page 2 Description**

Item	Description
1	Type the default warning time in seconds.
2	Type the default failure time in seconds.

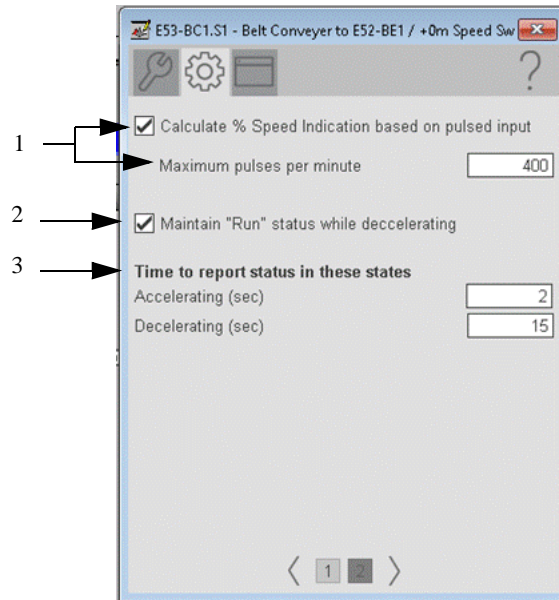
### Engineering Tab

The engineering tab provides access to device configuration parameters and ranges, options for device and I/O setup, displayed text, and faceplate-to-faceplate navigation settings, for initial system commissioning or later system changes.



**Table 96 - Engineering Tab Page 1 Description**

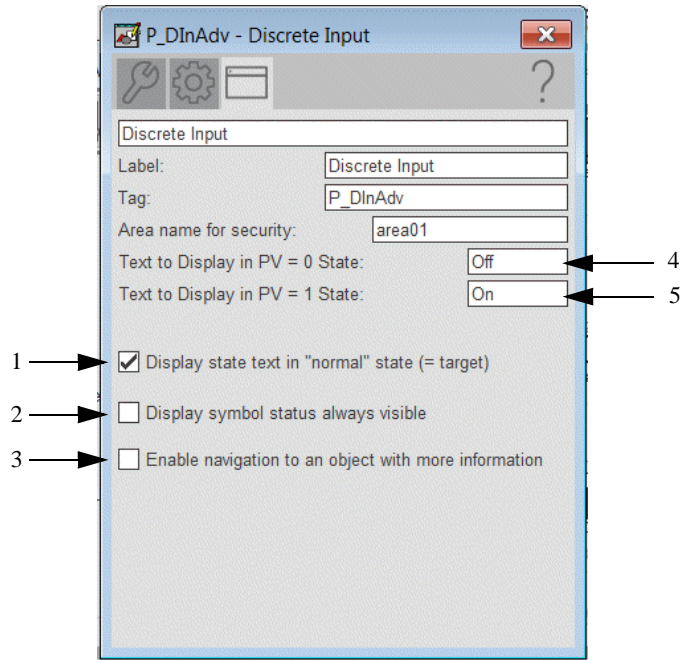
Item	Description
1	Check to enable the substitute Process Variable feature.
2	Check if the device has warning and failure indicators.
3	Check to enable the speed switch functionality.
4	Check to enable the speed feedback functionality.
5	Type the low speed threshold. (used as a percentage of maximum speed out of 100%)
6	Check to monitor the run feedback from the equipment. If run feedback is detected, the P_DInAdv state changes to Run. The “Run” status will be updated even if the “Accelerating” state timer has not expired.
7	Select to choose when the speed switch shows At Speed.

**Table 97 - Engineering Tab Page 2 Description**

Item	Description
1	Check the feature and enter the maximum number of pulses expected per minute. The derived speed of the equipment being monitored is indicated as a percentage out of a 100.
2	Check to maintain Run status while decelerating. By default the Run status is immediately reset during the state of Decelerating. For sequence programming, it may be a requirement to maintain the Run Status while the equipment is coasting to a stop
3	Type the time to report the status in each state. The state will be reported for the entire duration of the set time.

### HMI Configuration Tab

Configure the description, label, tag, and security area for the device. See [Basic Faceplate Attributes on page 32](#) for the description of the common attributes.



**Table 98 - HMI Configuration Description**

Item	Description
1	Check to display state text in normal state
2	Check to always display the symbol. If selected, the Speed Switch states, Acc, Run, Decc, or Stop will be displayed with the Tag Label on the global symbol. The default is to only display the Label.
3	Check to enable navigation to an object with more information (Cfg_HasMoreObj is set to true.) This can be configured to navigate to an AOI backing tag or a UDT tag that has HMI_Type and HMI_Lib defined. For example, there is a motor with the tag name P_101 and there is a need to have the more information button navigate to the parent P_LLS object. A tag is created for the P_LLS object that is given the alias P101_More. When the more information button is pressed on the motor, it links to P101_More. This will open the faceplate for the LLS object.
4	Type text to display in PV 0 State.
5	Type text to display in PV 1 State.

### Alarms Tab

The Alarms tab displays each configured alarm. The icon on the tab for the alarms page changes color to show the current active alarm status. A blinking alarm icon indicates that one or more alarms must be acknowledged or the

device must be reset. See [Common Alarm Block \(P\\_Alarm\) on page 66](#) for more information.

## Discrete Output (P\_DOut)


The Discrete Output (P\_DOut) Add-On Instruction controls a device by one discrete output signal and optionally monitors feedback from the device to check for device failures. The P\_DOut instruction operates in various command sources, and can provide steady, single pulsed, or continually pulsed output.

This document is for the visualization files, display elements, global objects, and HMI information. The operation of the Add-on Instructions and controller code is contained in publication [PROCES-RM013](#).

### Display Elements

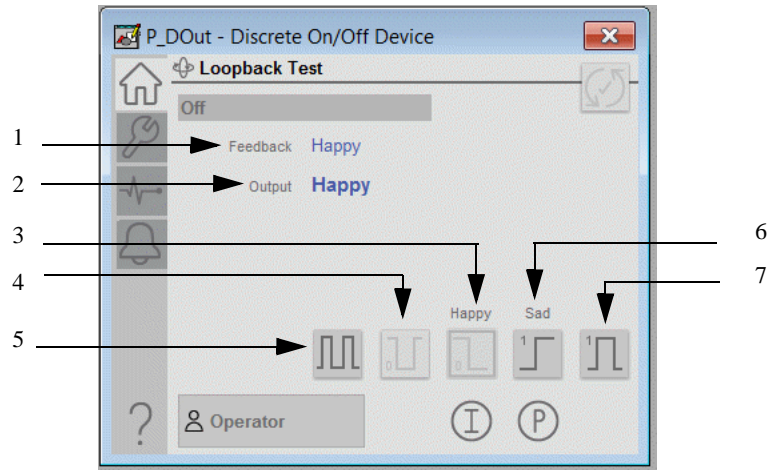
A display element (global object) is created once and can be referenced multiple times on multiple displays in an application. When changes are made to the original (base) object, the instantiated copies (reference objects) are automatically updated. Use of global objects, with tag structures in the ControlLogix system, aid consistency and save time.

**Table 99 - P\_DOut Display Elements Description**

Display Element Name	Display Element	Description
GO_P_DOut		Digital (2-state) device display element for use on overview and detail displays.

## Operator Tab

The Faceplate initially opens to the Operator (Home) tab. From here, an operator can monitor the device status and manually operate the device when it is in Operator command source.

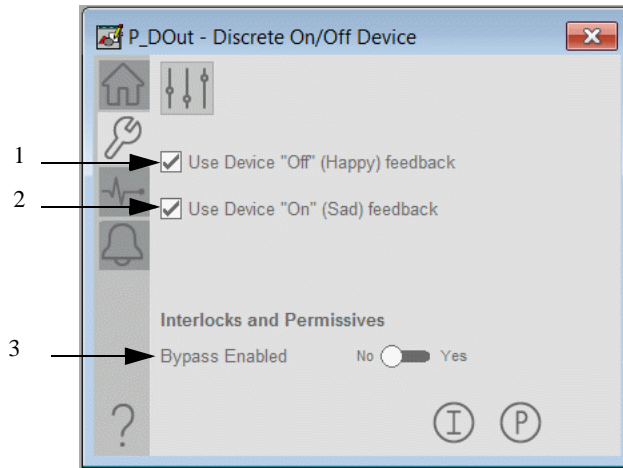


**Table 100 - Operator Tab Description**

Item	Description
1	Feedback Indicator
2	Discrete Output Indicator
3	Output 'Off' Button
4	Single Pulse 'Off' Button
5	Continuous Pulse Button
6	Output 'On' Button
7	Single Pulse 'On' Button

## Maintenance Tab

Maintenance personnel use the information and controls on the Maintenance tab to adjust device parameters, troubleshoot, temporarily work around device problems, and disable the device for routine maintenance.



**Table 101 - Maintenance Tab Description**

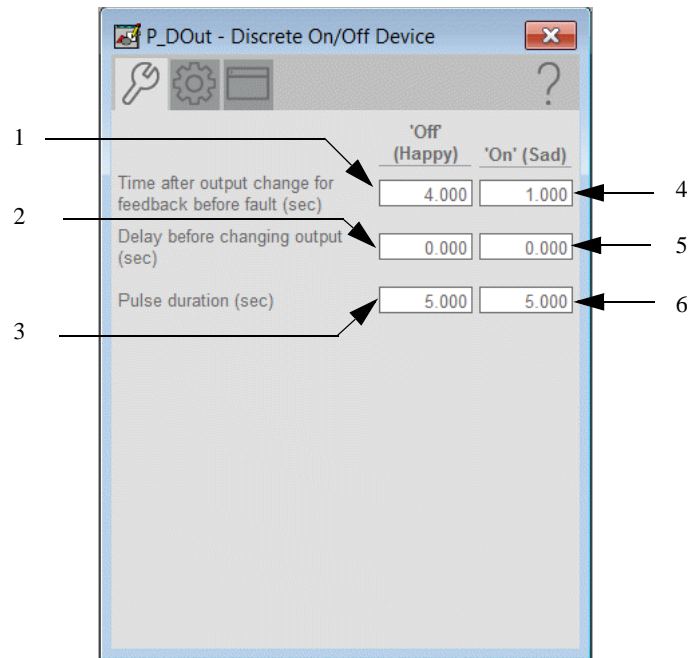
Item	Description
1	Check if the instruction uses the Off device feedback to check for failure.
2	Check if the instruction uses the On device feedback to check for failure.
3	Check if bypassable interlocks and permissives are bypassed in override command source.



## Advanced Properties Display

The Advanced Properties Display provides access to device configuration parameters and ranges, and options for device and I/O setup. The Advanced Maintenance, Engineering, and HMI configuration tabs can be reached from the Advanced Properties Display. This tab is used for initial system commissioning or later system changes.

### Advanced Maintenance Tab

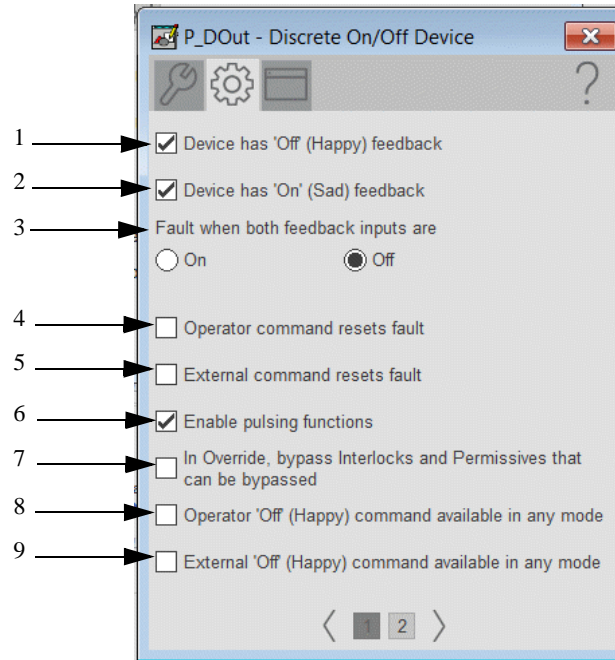


**Table 102 - Advanced Property Tab Description**

Item	Description
1	Type the amount of time to allow for the device to get feedback for the Off setting before setting a fault.
2	Type the amount of time before the output deactivates.
3	Type the amount of time to trigger a pulse when the device deactivates.
4	Type the amount of time to allow for the device to get feedback for the On setting before setting a fault.
5	Type the amount of time before the output activates.
6	Type the amount of time to trigger a pulse when the device deactivates.

### Engineering Tab

The engineering tab provides access to device configuration parameters and ranges, options for device and I/O setup, displayed text, and faceplate-to-faceplate navigation settings. This tab is also used for initial system commissioning or later system changes.



**Table 103 - Engineering Tab Page 1 Description**

Item	Description
1	Check to configure the instruction to use Off feedback signals from the device.
2	Check to configure the instruction to use On feedback signals from the device.
3	Click to Enable fault when both feedback inputs are either ON or OFF.
4	Check to reset a fault upon an operator command. Clear this checkbox to reset faults by using only the reset code.
5	Check to reset a fault upon an external command. Clear this checkbox to reset faults by using only the reset code.
6	Check to enable the pulsing functions.
7	Check if bypassable interlocks and permissives are bypassed in override command source.
8	Check to make the Operator Off command available in any command source. Clear this checkbox to make the Operator Off command available only in Operator or Maintenance command source.
9	Check to make the External Off command available in any command source. Clear this checkbox to make the External Off command available only in Operator or Maintenance command source.

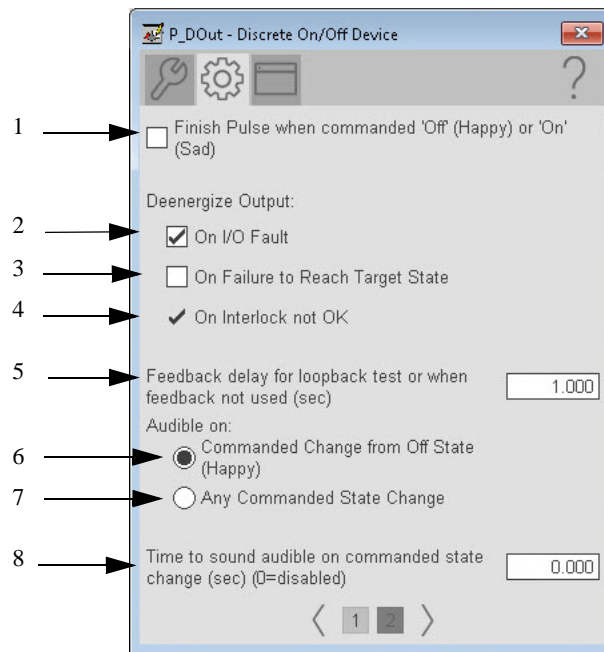
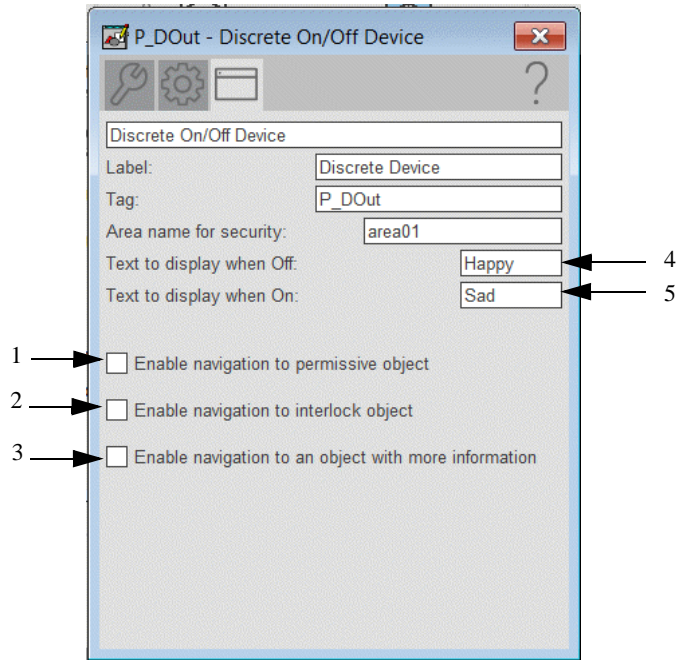


Table 104 - Engineering Tab Page 2 Description

Item	Description
1	Check to finish pulse when commanded ON or OFF.
2	Check to de-energize the output to the device and return the device to its fail position, when an I/O Fault condition occurs. Clear this checkbox to keep the output to the device in its current stat on an I/O Fault condition. <b>IMPORTANT:</b> If a condition is configured to shed the device to the Off state on a fault, a reset is required to clear the shed fault. This reset commands the device to a state other than Off.
3	Check to de-energize the output to the device, return it to its fail position, when a Position Fail condition occurs. Clear this checkbox to keep the output to the device in its current state (keep trying) on a Position Fail condition. <b>IMPORTANT:</b> If a condition is configured to shed the device to the Off state on a fault, a reset is required to clear the shed fault. This reset commands the device to a state other than Off.
4	The device outputs are always de-energized on an Interlock not OK. This item cannot be unchecked. It is displayed as a reminder that the Interlock not OK function always de-energizes the device.
5	Sets the time delay (in seconds) for the On or Off status to be echoed back when Simulation is enabled or when On and Off feedbacks are not used.
6	Click to sound an audible on a commanded stage from the OFF State.
7	Click to sound an audible on a commanded stage from any State.
8	Type the time (in seconds) that the audible sounds when there is a commanded State change.

### HMI Configuration Tab

Configure the description, label, tag, and security area for the device. See [Basic Faceplate Attributes on page 32](#) for the description of the common attributes.



**Table 105 - HMI Configuration Descriptions**

Item	Description
1	Check if a permissive instruction is used with this device. This check changes the Permissive indicator to a clickable button to open the Permissive faceplate. <b>IMPORTANT:</b> The name of the Permissive object in the controller must be the name of the object with the suffix '_Perm'. For example, if your P_DOut object has the name 'DOut123', then its Permissive object must be named 'DOut123_Perm'.
2	Check if an interlock instruction is used with this device. This check changes the Interlock indicator to a clickable button to open the Interlock faceplate. <b>IMPORTANT:</b> The name of the interlock object in the controller must be the name of the object with the suffix '_Intlk'. For example, if your P_DOut object has the name 'DOut123', then its interlock object must be named 'DOut123_Intlk'.
3	Check to enable navigation to an object with more information (Cfg_HasMoreObj is set to true.) This can be configured to navigate to an AOI backing tag or a UDT tag that has HMI_Type and HMI_Lib defined. For example, there is a motor with the tag name P_101 and there is a need to have the more information button navigate to the parent P_LLS object. A tag is created for the P_LLS object that is given the alias P101_More. When the more information button is pressed on the motor, it links to P101_More. This will open the faceplate for the LLS object.
4	Type text to display when device is in Off (0) state.
5	Type text to display when device is in On (1) state.

## Diagnostics Tab

The Diagnostic tab provides indications that are helpful to diagnose or help prevent device problems. The device problems can include specific reasons a device is 'Not Ready', device warnings and faults, warning and fault history, and predictive/preventive maintenance data.

The Diagnostics tab displays possible reasons for the device not being ready. See [Diagnostics Tab on page 36](#)

## Alarms Tab

The Alarms tab displays each configured alarm. The icon on the tab for the alarms page changes color to show the current active alarm status. A blinking alarm icon indicates that one or more alarms must be acknowledged or the device must be reset. See [Common Alarm Block \(P\\_Alarm\) on page 66](#) for more information.

# Analog Output (P\_AOut)

The P\_AOut (Analog Output) Add-On Instruction is used to manipulate an analog output to control a field device, such as a control valve or a motorized gate positioner. The output responds to an Operator (manual) or Program setting of the Controlled Variable (CV) signal.






The P\_AOut instruction controls the analog output in various command sources (Operator, Program, Override, Maintenance, Hand), monitoring for fault conditions.

This document is for the visualization files, display elements, global objects, and HMI information. The operation of the Add-on Instructions and controller code is contained in publication [PROCES-RM013](#).

## Display Elements

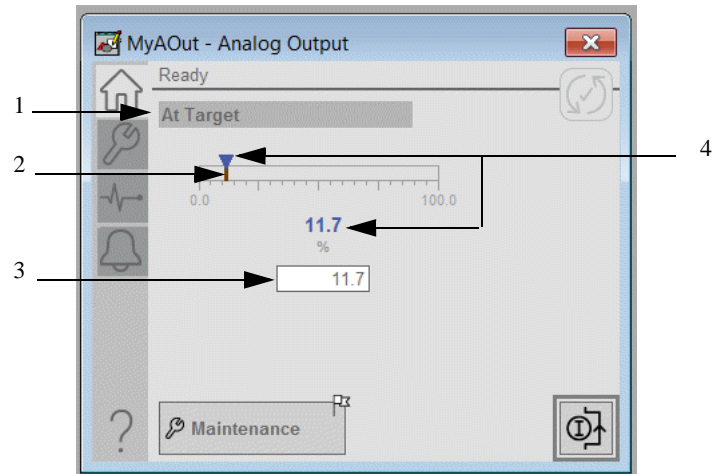
A display element (global object) is created once and can be referenced multiple times on multiple displays in an application. When changes are made to the original (base) object, the instantiated copies (reference objects) are automatically updated. Use of global objects, with tag structures in the ControlLogix system, aid consistency and save engineering time.

**Table 106 - P\_AOut Display Elements Description**

Display Element Name	Display Element	Description
GO_P_AOut		Standard analog-output global object.
GO_ProcessControlValve		Normal controlled valve symbol for horizontal pipe.
GO_ProcessControlValve1		Inverted controlled valve symbol for horizontal pipe.
GO_ProcessControlValve2		Controlled valve symbol for vertical pipe (pipe to the left).
GO_ProcessControlValve3		Controlled valve symbol for vertical pipe (pipe to the right).

## Operator Tab

The Faceplate initially opens to the Operator (Home) tab. From here, an operator can monitor the device status and manually operate the device when it is in Operator command source.

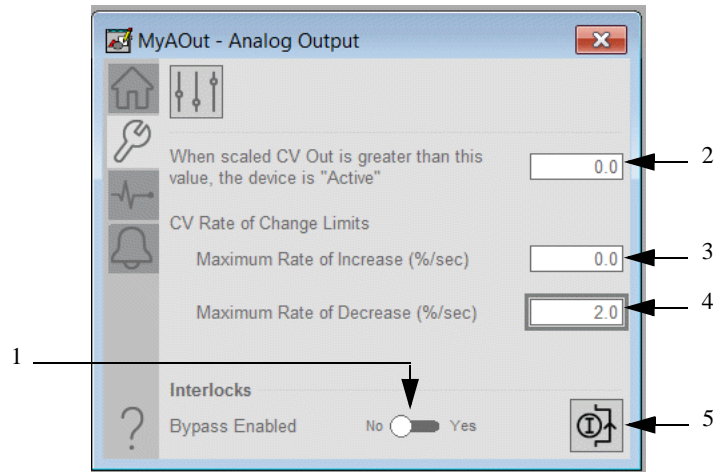


**Table 107 - Operator Tab Description**

Item	Description
1	Analog Output State (At Target, Ramping Down, Ramping Up, Clamped at Min, Clamped at Max, or Disabled).
2	Control Variable target.
3	Type to change the Controlled Variable output value.
4	Control Variable.

## Maintenance Tab

Maintenance personnel use the information and controls on the Maintenance tab to adjust device parameters, troubleshoot and temporarily work around device problems, and disable the device for routine maintenance.



**Table 108 - Maintenance Tab Description**

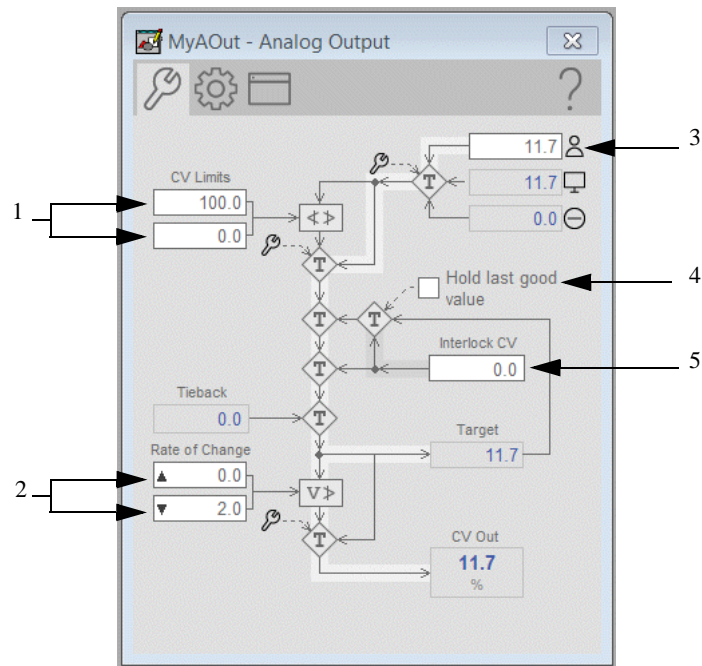
Item	Description
1	Click YES to bypass checking of bypassable interlocks and permissives.
2	Type the CV value above which the device shows as 'Active'. When Val_CVOut is greater than this value, Sts_Active is set to 1, and the HMI shows the graphic symbol in the active state (for example, control valve shown as Open). When Val_CVOut is less than or equal to this value, Sts_Active is set to 0, and the HMI shows the graphic symbol in the inactive state (for example, control valve shown as Closed).
3	Type the Rate of Change Limit for increasing the Control Variable.
4	Type the Rate of Change Limit for decreasing the Control Variable.
5	Displays the interlocks faceplate P_Intlk.



## Advanced Properties Display

The Advanced Properties Display provides access to device configuration parameters and ranges, and options for device and I/O setup. The advanced maintenance, engineering tab, and the HMI configuration tab can be reached from the Advanced Properties Display. This tab is used for initial system commissioning or later system changes.

### Advanced Maintenance Tab

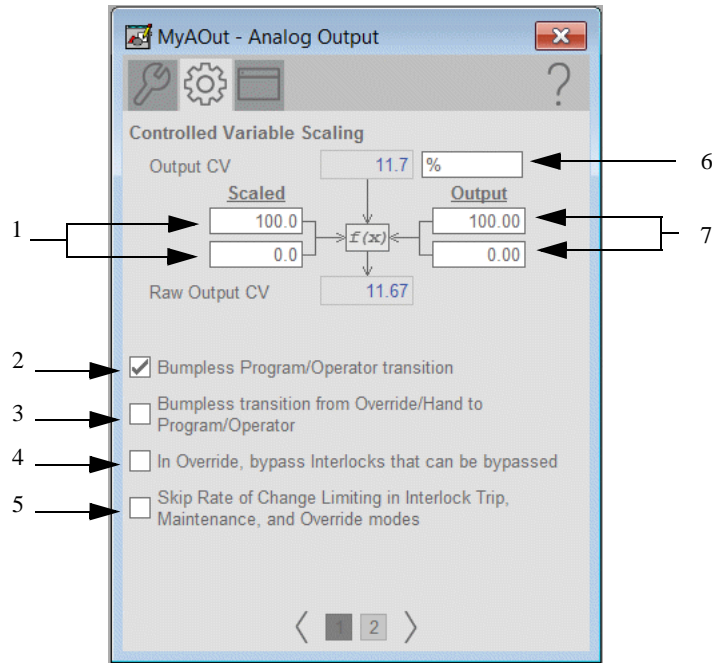


**Table 109 - Advanced Properties Display Description**

Item	Description
1	Controlled Variable clamp limits. Type the clamping limits for the Controlled Variable in engineering units. Clamp limits are enforced in Operator and Program command sources only.
2	Type the maximum allowed value for the Rate of Change Limit in engineering units per second. A value of zero allows any rate of change to be input by the Program or Operator.
3	Type the Operator command source Controlled Variable Target in engineering units. This entry is available in Operator command source and Maintenance command source.
4	Check and the Controlled Variable holds at the last good value when an Interlock trips or an I/O Fault occurs. Clear this checkbox and the Controlled Variable goes to the Interlock Controlled Variable value when an Interlock trips or an I/O Fault occurs.
5	Type the interlock target Controlled Variable in engineering units. This value is used for the Controlled Variable when interlocked or on an I/O Fault, but only if Hold Last Good Value is not selected.

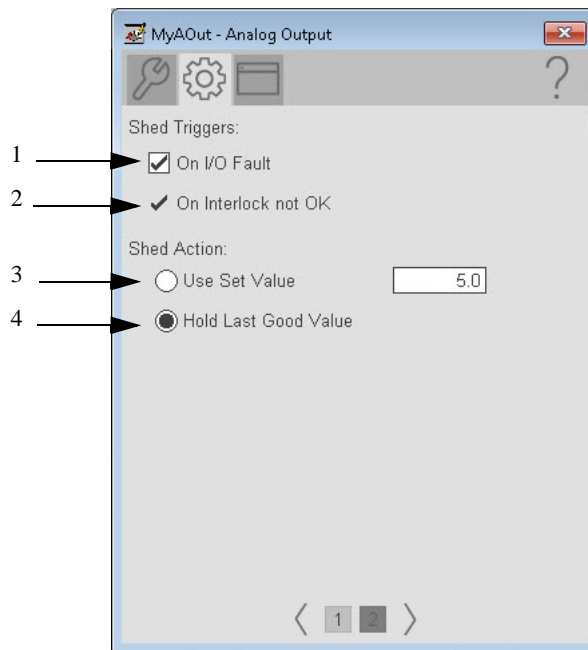
### Engineering Tab

The engineering tab provides access to device configuration parameters and ranges, options for device and I/O setup, displayed text, and faceplate-to-faceplate navigation settings. This tab is also used for initial system commissioning or later system changes.



**Table 110 - Engineering Tab Page 1 Description**

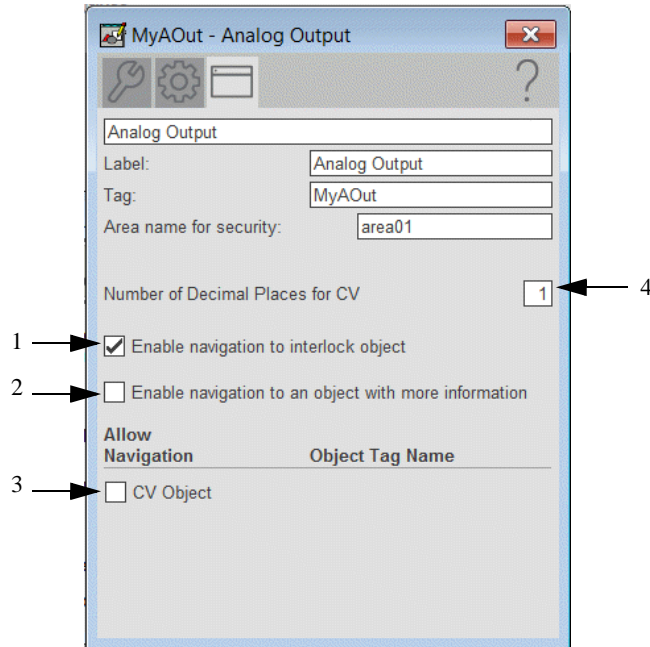
Item	Description
1	Type values for the maximum and minimum scaled (engineering units) scaling ranges.
2	When checked, the operator settings track the program settings when the command source is Program, and program settings track the operator settings when the command source is Operator. Transition between command sources is bumpless. When not checked, the operator settings and program settings retain their values regardless of command source. When the command source is changed, the value of a limit can change, such as from the Program-set value to the Operator-set value.
3	When checked, the Program and Operator Settings of the CV track the output CV when the command source is Hand or Override.
4	Check while in Override command source to bypass Interlocks that can be bypassed.
5	Check to have the CV immediately go to its target value or configured Interlock CV value when an Interlock trips or the instruction is placed in Maintenance or Override command source. Clear this checkbox to have the CV always use rate of change limiting (ramping) of the CV output.
6	Engineering Units label.
7	Type values for the maximum and minimum output (Raw) scaling ranges.

**Table 111 - Engineering Tab Page 2 Description**

Item	Description
1	Check so that an I/O Fault triggers a shed of the output, to the configured shed set value or to hold last good output. The shed condition is latched internal to the Add-On Instruction. When the I/O Fault condition clears, a Reset command is required to return to normal operation. Clear this checkbox so that the I/O Fault condition does not affect operation (but can still generate an alarm).
2	This selection cannot be changed. The configured shed action always takes place on an interlock not ok.
3	Choose this option to set the analog output to the configured shed set value when a condition configured as a shed trigger occurs.
4	Choose this option to hold the analog output at its last good value when a condition configured as a shed trigger occurs.

### HMI Configuration Tab

Configure the description, label, tag, and security area for the device. See [Basic Faceplate Attributes on page 32](#) for the description of the common attributes.



**Table 112 - HMI Configuration Description**

Item	Description
1	Check if an interlock object is connected to Inp_IntlkOK. The Interlock indicator becomes a button that opens the P_Intlk faceplate. <b>IMPORTANT:</b> The name of the Interlock object in the controller must be the name of the object with the suffix ‘_Intlk’. For example, if your P_AOut object has the name ‘AOut123’, then its Interlock object must be named ‘AOut123_Intlk.
2	Check to enable navigation to an object with more information (Cfg_HasMoreObj is set to true.) This can be configured to navigate to an AOI backing tag or a UDT tag that has HMI_Type and HMI_Lib defined. For example, there is a motor with the tag name P_101 and there is a need to have the more information button navigate to the parent P_LLS object. A tag is created for the P_LLS object that is given the alias P101_More. When the more information button is pressed on the motor, it links to P101_More. This will open the faceplate for the LLS object.
3	Check to enable navigation to the faceplate for the PlantPax® object that is providing the CV for this object (PSet_CV).
4	Set the number of decimal places for the Control Variable.

## **Diagnostics Tab**

The Diagnostic tab provides indications that are helpful to diagnose or help prevent device problems. The device problems can include specific reasons a device is 'Not Ready', device warnings and faults, warning and fault history, and predictive/preventive maintenance data.

The Diagnostics tab displays possible reasons for the device not being ready. See [Diagnostics Tab on page 36](#)

## **Alarms Tab**

The Alarms tab displays each configured alarm. The icon on the tab for the alarms page changes color to show the current active alarm status. A blinking alarm icon indicates that one or more alarms must be acknowledged or the device must be reset. See [Common Alarm Block \(P\\_Alarm\) on page 66](#) for more information.

## **Pressure/Temperature Compensated Flow (P\_PTComp)**

The Pressure/Temperature Compensated Flow (P\_PTComp) Add-On Instruction is used to calculate a flow at standard temperature and pressure. This Add-On Instruction essentially calculates a mass flow rate when given a volumetric flow rate or differential pressure measurement. This instruction also requires measurements of the actual temperature and pressure of the flowing gas. There is no graphical HMI for this instruction. More details on this instruction can be found in PROCES-RM003.

This document is for the visualization files, display elements, global objects, and HMI information. The operation of the Add-on Instructions and controller code is contained in publication [PROCES-RM013](#).

## **Tank Strapping Table (P\_StrapTbl)**

The P\_StrapTbl (Tank Strapping Table) Add-On Instruction calculates the volume of product in an upright cylindrical tank when given the level of the product and the tank calibration table. This instruction can optionally compensate for free water at the bottom of the tank (given a product/water interface level). This instruction can also compensate for thermal expansion of the tank shell (given the coefficient of linear expansion of the shell material and product and ambient temperatures). There is no graphical HMI for this instruction. More details on this instruction can be found in PROCES-RM003.

This document is for the visualization files, display elements, global objects, and HMI information. The operation of the Add-on Instructions and controller code is contained in publication [PROCES-RM013](#).

## Regulatory and Procedural Control Family

Library objects in this section comprise two groups of Advanced Process Control: regulatory and procedural.

- Regulatory control focuses on the process variables (levels, flows, temperatures, pressures, and so on). The control is designed to improve loops that perform poorly and automate loops that are typically run in manual by the operator. These loops include techniques such as ratio, feed-forward, cascade, and decoupling control. Regulatory control variables include:
  - Proportional + Integral + Derivative Enhanced (P\_PIDE)
  - Analog Fanout (P\_Fanout)
  - High or Low Selector (P\_HiLoSel)
  - Deadband Controller (P\_DBC)
- Procedural control focuses on the product being manufactured (cement, polyethylene, ethanol, paper, and so on). The objects control the various product specifications and parameters via a series of discrete sequential actions. Procedural control variables include:
  - Sequencer Object (P\_Seq)
  - Flowmeter Dosing / Weigh Scale Dosing (P\_Dose)
  - Lead/Lag/Standby Motor Group (P\_LLS)

This document is for the visualization files, display elements, global objects, and HMI information. The operation of the Add-on Instructions and controller code is contained in publication [PROCES-RM013](#).

## Proportional + Integral + Derivative Enhanced (P\_PIDE)





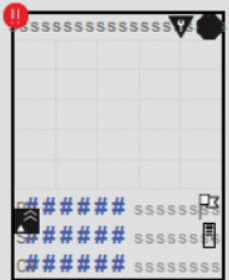
The P\_PIDE (Proportional + Integral + Derivative Enhanced) Add-On Instruction provides the functionality of the Studio 5000 Logix Designer® PIDE function block. This Add-On Instruction provides a user experience consistent with the rest of the Rockwell Automation Library of Process Objects.

This document is for the visualization files, display elements, global objects, and HMI information. The operation of the Add-on Instructions and controller code is contained in publication [PROCES-RM013](#).

### Display Elements

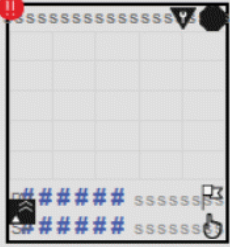
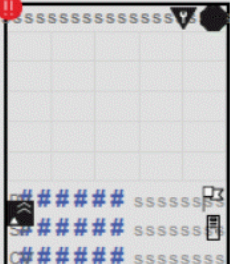
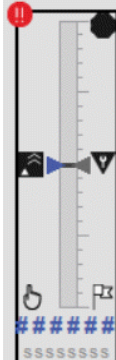




A display element (global object) is created once and can be referenced multiple times on multiple displays in an application. When changes are made to the original (base) object, the instantiated copies (reference objects) are automatically updated. Use of global objects, with tag structures in the ControlLogix® system, aid consistency, and save engineering time.

**Table 113 - P\_PIDE Display Elements Description**

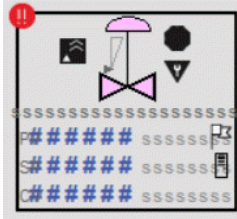
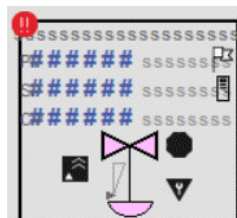

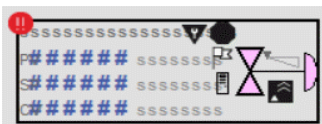

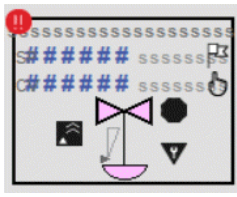


Display Element Name	Display Element	Description
GO_P_PID		Display element with PV and CV numeric displays.
GO_P_PID1		Display element with PV, SP, and CV numeric displays.
GO_P_PID2		Display element with SP and CV numeric displays.
GO_P_PID_Trend		Display Element with PV and CV numeric displays and a trend display that plots SP, PV, High, and Low Deviations. The trend is scaled to PV EU Min and Max.
GO_P_PID_Trend1		Display Element with PV, SP, and CV numeric displays and a trend display that plots SP, PV, High, and Low Deviations. The trend is scaled to PV EU Min and Max.



**Table 113 - P\_PIDE Display Elements Description**

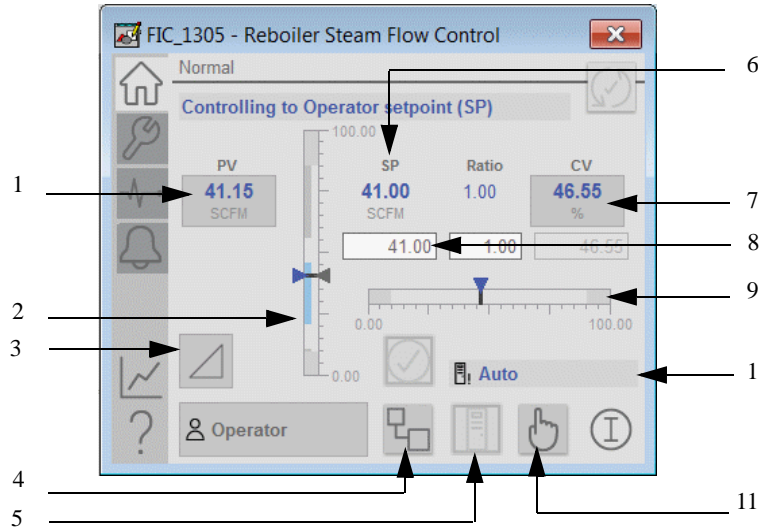
Display Element Name	Display Element	Description
GO_P_PID_TrendWTarget		Display Element with PV and CV numeric displays and a trend display that plots SP, PV, High, and Low Deviations. The trend is scaled by using the High and Low Deviations.
GO_P_PID_TrendWTarget 1		Display Element with PV, SP, and CV numeric displays and a trend display that plots SP, PV, High, and Low Deviations. The trend is scaled by using the High and Low Deviations.
GO_P_PID_Indicator		Bar graph with SP on the left and PV on the right that is scaled by PV EU minimum and maximum.
GO_P_PID_Valve		Proportional Valve display element with PV and CV numeric displays.
GO_P_PID_Valve1		
GO_P_PID_Valve2		
GO_P_PID_Valve3		

**Table 113 - P\_PIDE Display Elements Description**

Display Element Name	Display Element	Description
GO_P_PID_Valve4		Proportional Valve display element with PV, CV, and Setpoint numeric displays.
GO_P_PID_Valve5		
GO_P_PID_Valve6		
GO_P_PID_Valve7		
GO_P_PID_Valve8		Proportional Valve display element with SP, CV, and Setpoint numeric displays.
GO_P_PID_Valve9		
GO_P_PID_Valve10		
GO_P_PID_Valve11		

## Operator (Home) Tab

The Faceplate initially opens to the Operator (Home) tab. From here, an operator can monitor the device status and manually operate the device when it is in Operator command source. Several features are common to all Add-On Instructions faceplates. See [Basic Faceplate Attributes on page 32](#).



**Table 114 - Operator Tab Description**

Item	Description
1	Current Process Variable (PV).
2	Bar graph for the current Process Variable.
3	Click to open the ramp wizard display. See <a href="#">Ramp Wizard Display on page 172</a> .
4	Cascade loop mode.
5	Auto loop mode.
6	Current Setpoint (SP).
7	Current Control Variable (CV).
8	Type a value for the loop setpoint. <b>IMPORTANT:</b> This value can be entered only when the instruction command source is Operator and the Loop mode is Automatic or Manual.
9	Bar graph for the current Control Variable.
10	Loop mode indicator.
11	Cascade loop mode.

Figure 14 - Ramp Wizard Display

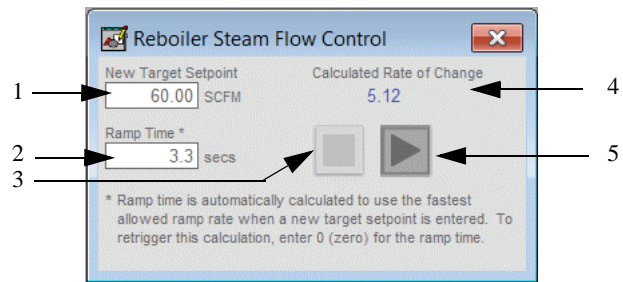
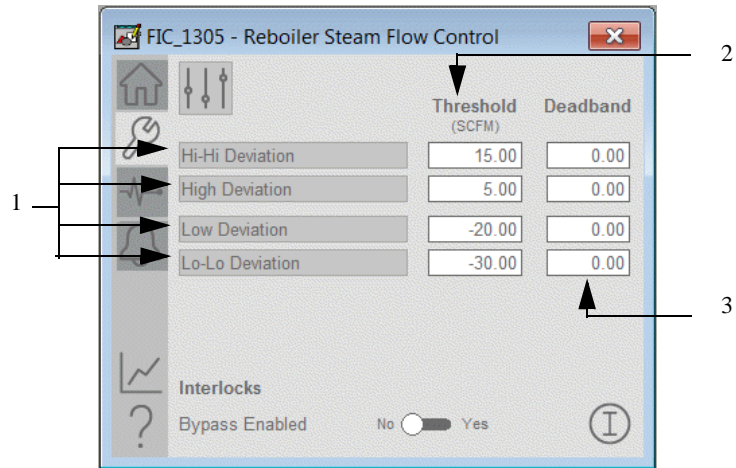


Table 115 - Ramp Wizard Display Description

Item	Description
1	Type new target setpoint.
2	Ramp Time.
3	Stop setpoint ramping.
4	Calculated rate of change.
5	Start setpoint ramping.

## Maintenance Tab

Maintenance personnel use the information and controls on the Maintenance tab to adjust device parameters, troubleshoot, temporarily work around device problems, and disable the device for routine maintenance. Several features are common to all Add-On Instructions faceplates. See [Basic Faceplate Attributes on page 32](#)



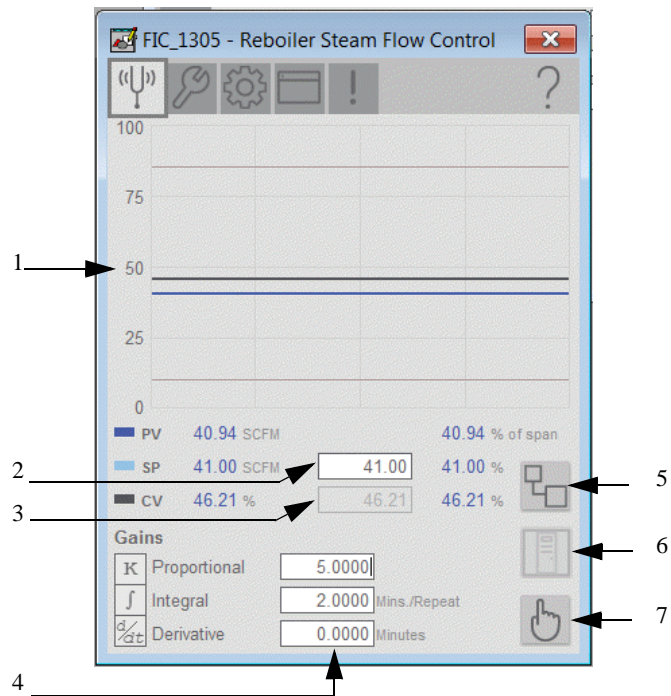
**Table 116 - Maintenance Tab Description**

Item	Description
1	Threshold Name: Click a threshold name to open the associated P_Gate faceplate.
2	Type the threshold (trip point) for analog input alarms.
3	Type the deadband (hysteresis) that applies to each alarm limit. Deadband helps prevent a noisy signal from generating numerous spurious alarms. Example: If the High alarm limit is 90.0 and the High alarm deadband is 5, once the signal rises above 90.0 and generates a High alarm. The signal must fall below 85.0 (90.0 minus 5.0) for the alarm to clear.

## Advanced Properties

Click the advanced properties graphic. The tuning, advanced maintenance, engineering, HMI configuration, and faults settings are available.

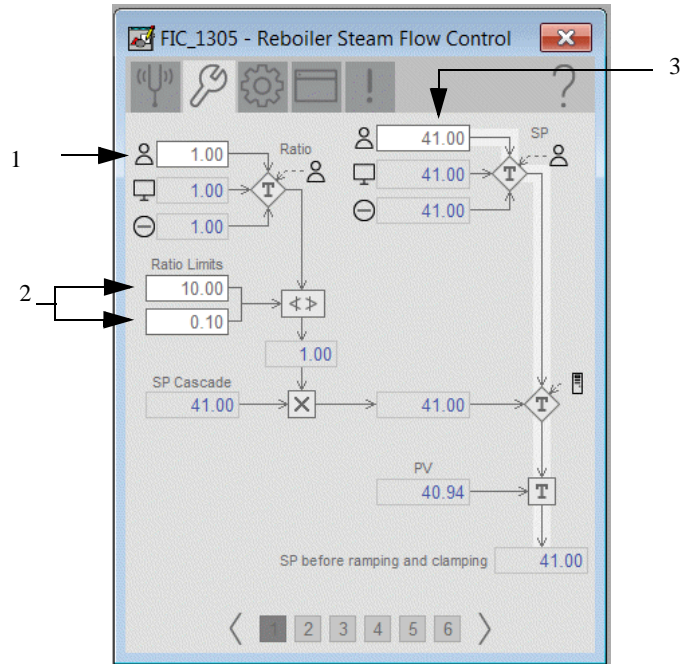
### Tuning



**Table 117 - Tuning Tab Description**

Item	Description
1	Trend display for Process Variable, Setpoint, and Controlled Variable.
2	Setpoint data entry.
3	Process variable data entry.
4	Tuning constant entries.
5	Cascade loop mode.
6	Auto loop mode.
7	Manual loop mode.

*Advanced Maintenance Tab Page 1*



**Table 118 - Advanced Maintenance Tab 1 Description**

Item	Description
1	Type the Operator ratio.
2	Type the maximum and minimum limits for the ratio.
3	Type the Operator Setpoint for the Operator Loop mode.

Advanced Maintenance Tab Page 2

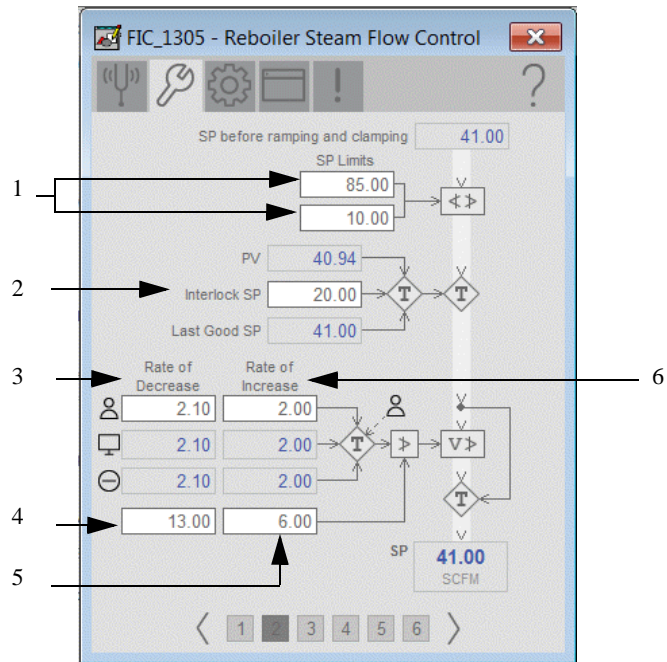


Table 119 - Advanced Maintenance Tab Page 2 Description

Item	Description
1	Type the maximum and minimum limits for the setpoint.
2	Type the interlock setpoint.
3	Type the operator setpoint rate of decrease limit.
4	Type the maximum setpoint rate of decrease.
5	Type the maximum setpoint rate of increase.
6	Type the operator setpoint rate of increase limit.



## Advanced Maintenance Tab Page 3

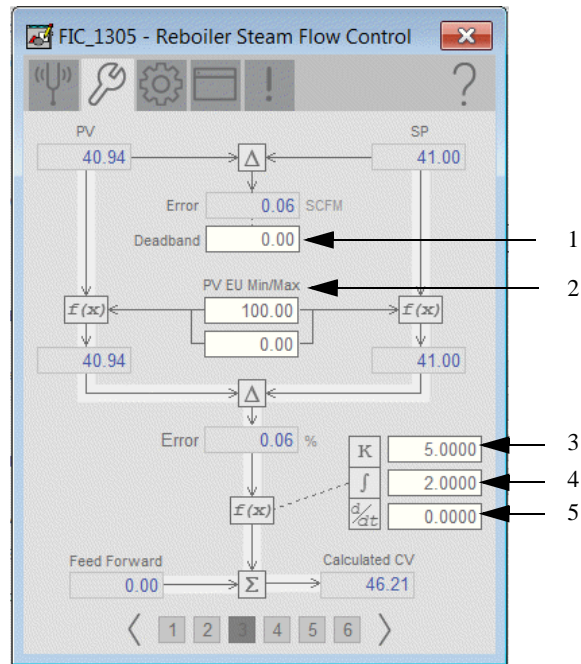


Table 120 - Advanced Maintenance Tab 3 Description

Item	Description
1	Type the value for the zero-crossing deadband (in PV engineering units). When the loop error is less than the zero-crossing deadband, the loop output does not change. <b>IMPORTANT:</b> See the PIDE built-in instruction online help for more information.
2	Type the maximum and minimum values of the PV range (span) (in PV engineering units). The maximum value must be greater than the minimum.
3	Gains: Proportional  This value depends on the setting of Cfg_Depend. If Cfg_Depend = 1 (dependent gains, the default), type the Controller Gain (unitless). This gain is applied to the Proportional, Integral, and Derivative terms. If Cfg_Depend = 0 (independent gains), type the Proportional Gain (unitless). This gain is applied to the Proportional term only. A value of zero in either case disables the Proportional term of the controller. Negative values are not valid.
4	Gains: Integral  This value depends on the setting of Cfg_Depend. If Cfg_Depend = 1 (dependent gains, the default), type the Integral Time Constant (minutes pre-repeat). If Cfg_Depend = 0 (independent gains), type the Integral Gain (1/minutes). A value of zero in either case disables the Integral term of the controller. Negative values are not valid.

Item	Description
5	<p>Gains: Derivative</p> <p>This value depends on the setting of Cfg_Depend.                      If Cfg_Depend = 1 (dependent gains, the default), type the Derivative Time Constant (minutes).                      If Cfg_Depend = 0 (independent gains), type the Derivative Gain (minutes).                      A value of zero in either case disables the Derivative term of the controller.                      Negative values are not valid.</p>

Advanced Maintenance Tab Page 4

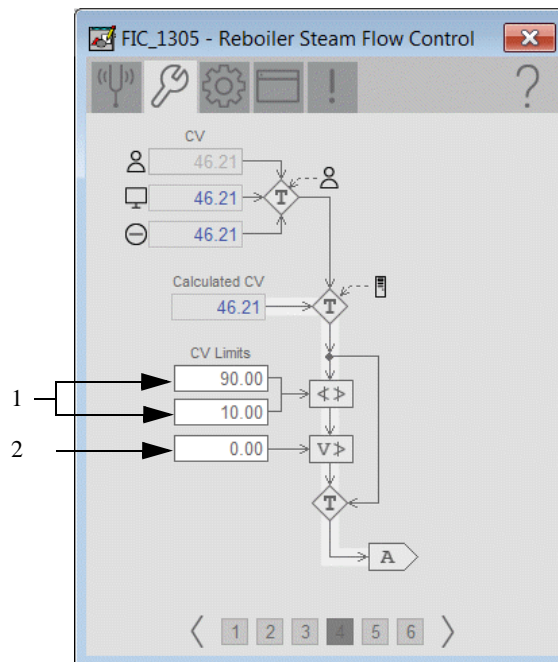


Table 121 - Advanced Maintenance Tab 4 Description

Item	Description
1	<p>Type the maximum allowed value of the CV in percent. The CV output is clamped not to exceed the entered value. This value must be less than or equal to 100.0 and greater than the CV Low Limit.</p> <p>Type the minimum allowed value of the CV in percent. The CV output is clamped not to go below the entered value. This value must be greater than or equal to 0.0 and less than the CV High Limit.</p>
2	<p>Type the maximum allowed CV rate of change in percent per second. A value of zero disables rate limiting. Negative values are not valid.</p>

## Advanced Maintenance Tab Page 5

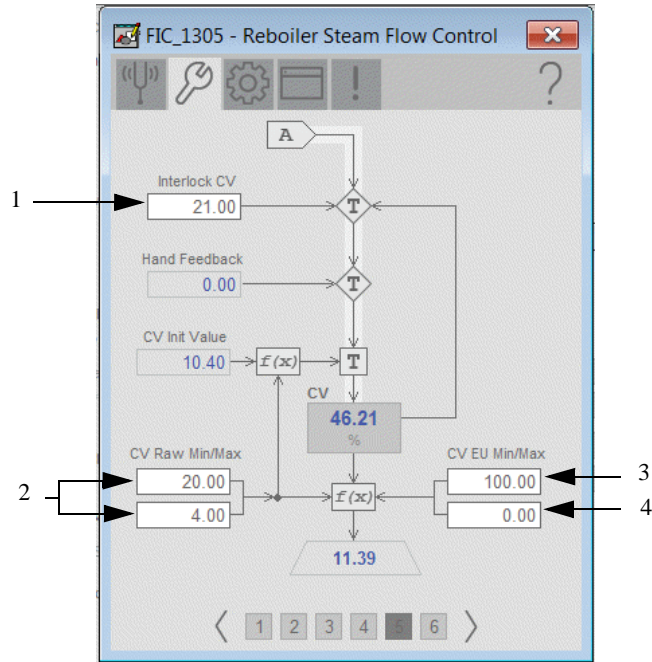
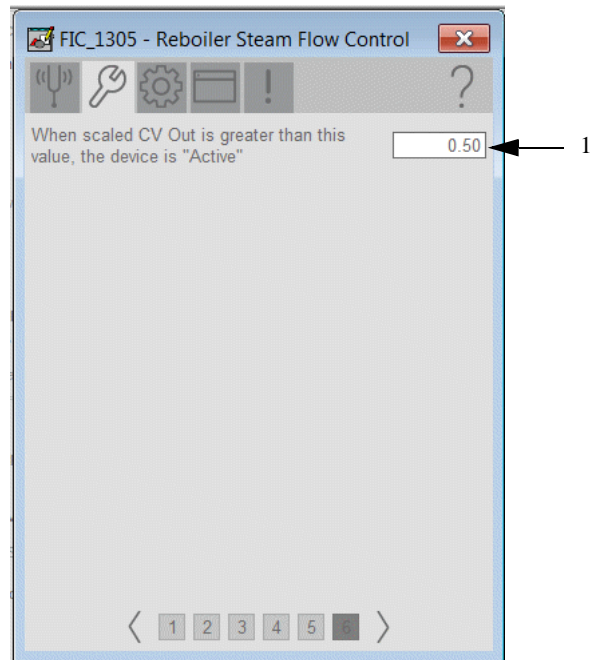


Table 122 - Advanced Maintenance Tab 5 Description

Item	Description
1	Type the value in percent to output as the CV when an Interlock input is not OK. The CV is held at this value until the interlock inputs are OK (subject to interlock bypassing).
2	Type the minimum/maximum value for the controlled variable limits.
3	Type the value of the output (in CV engineering units) that correspond to a CV of 100.0%. This value cannot equal the CV EU minimum.
4	Type the value of the output (in CV engineering units) that correspond to a CV of 0.0%.



**Table 123 - Advanced Maintenance Tab Page 6 Description**

Item	Description
1	Type the CV value. When Val_CVOut is greater than this value, Sts_Active is set to 1, and the HMI shows the graphic symbol in the active state (for example, control valve shown as Open). When Val_CVOut is less than or equal to this value, Sts_Active is set to 0, and the HMI shows the graphic symbol in the inactive state (for example, control valve shown as Closed).

## Engineering Tab Page 1

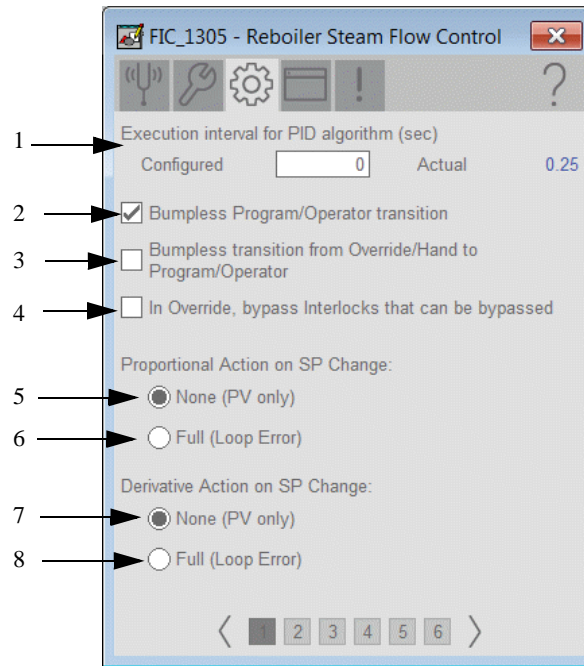


Table 124 - Engineering Tab Page 1 Description

Item	Description
1	Type the interval (in seconds) to execute the PID algorithm.
2	Check so that when this parameter is: <ul style="list-style-type: none"> <li>On, the operator settings track the program settings when command source is Program, and program settings track the operator settings when the command source is Operator. Transition between command sources is bumpless.</li> <li>Off, the operator settings and program settings retain their values regardless of command source. When the command source is changed, the value of a limit can change, such as from the Program-set value to the Operator-set value.</li> </ul>
3	Check so that Program and operator settings track when the command source is Hand or Override.
4	Check to bypass Interlocks that can be bypassed while in Override command source.
5	Click to have the Proportional action of the PID algorithm apply only to changes in the PV and ignore changes in setpoint.
6	Click to have the Proportional action of the PID algorithm apply to changes to the PV and to the setpoint.
7	Click to have the Derivative action of the PID algorithm apply only to the rate of change of the PV and ignore changes in setpoint.
8	Click to have the Derivative action of the PID algorithm apply to the rate of change of the PV and to the setpoint.

Engineering Tab 2

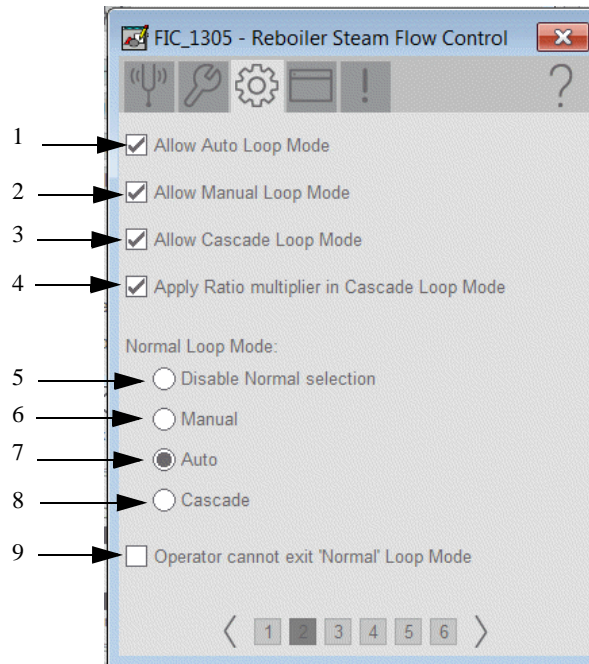
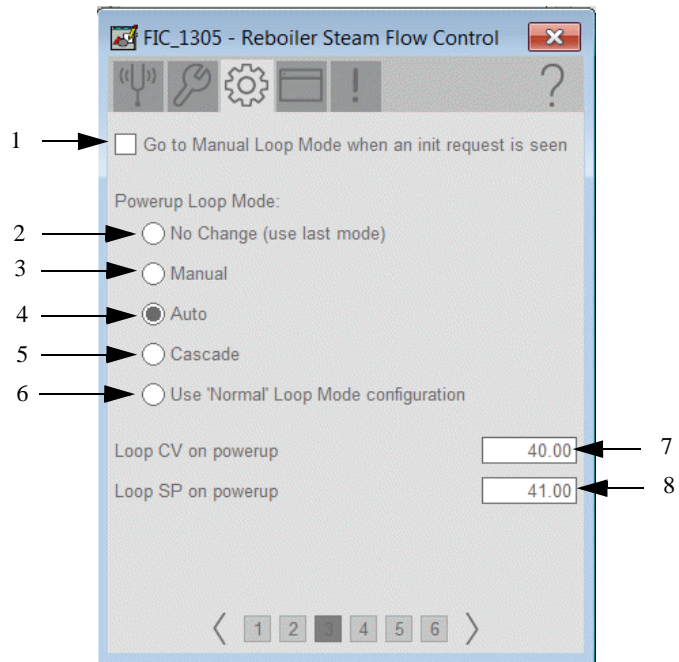


Table 125 - Engineering Tab Page 2 Description

Item	Description
1	Check to enable Auto Loop mode.
2	Check to enable Manual Loop mode.
3	Check to enable Cascade Loop mode.
4	Check to multiply the Cascade SP input by the ratio value to get the loop setpoint. Clear the checkbox to use the Cascade SP input as the loop setpoint directly.
5	Click to disable normal loop mode selection
6	Click to choose manual as the normal loop mode
7	Click to choose auto as the normal loop mode
8	Click to choose cascade as the normal loop mode
9	Check to allow the operator to select only the defined normal loop mode.

*Engineering Tab Page 3***Table 126 - Engineering Tab Page 3 Description**

Item	Description
1	Check to set the Loop mode to Manual when the Use CVInit Value input is true. The loop is left in manual with the CV at the initialization value when the initialization request clears. Clear this checkbox to leave the loop in its current mode on an initialization request. When the initialization request clears, the loop resumes controlling in its previous mode.
2	Click to keep the Loop mode what it was at powerdown.
3	Click to set the Loop mode to Manual on powerup.
4	Click to set the Loop mode to Auto on powerup.
5	Click to set the Loop mode to Cascade on powerup.
6	Click to keep the Loop mode what it was at powerdown.
7	Type a value to apply to the loop CV (in percent) on controller powerup. The CV is set to this value on controller powerup in Run mode and on controller transition from Program mode to Run mode.
8	Type a value to apply to the loop setpoint (in PV engineering units) on controller powerup. The setpoint is set to this value on controller powerup in Run mode and on controller transition from Program mode to Run mode.

Engineering Tab Page 4

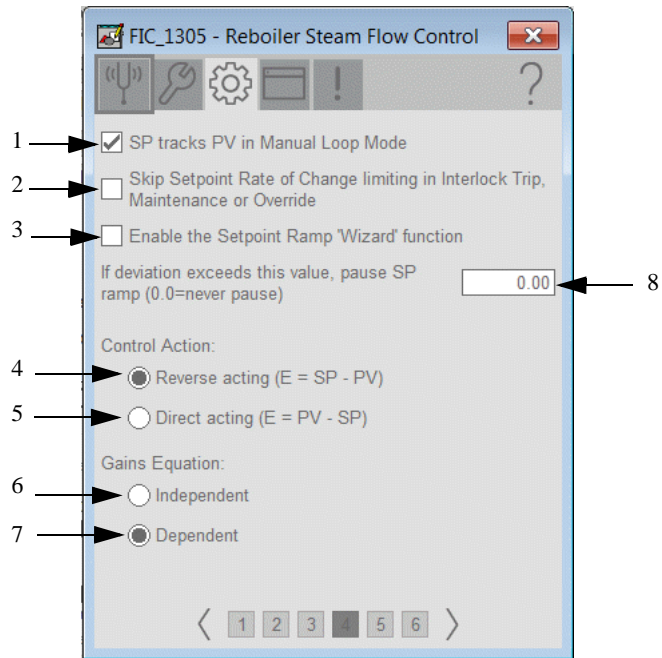


Table 127 - Engineering Tab Page 4 Description

Item	Description
1	Check to have the current PV copied to the SP (track) whenever the loop is in Manual mode.
2	Check to skip the setpoint rate of change limiting in Interlock Trip, Maintenance, or Override.
3	Check to allow navigation to the setpoint Ramp Wizard Display from the Operator tab. See <a href="#">Operator (Home) Tab on page 171</a> .
4	Click for reverse-acting loop response (default). When the PV increases, the CV (output) decreases.
5	Click for direct-acting loop response. When the PV increases, the CV (output) increases.
6	Click to use the Independent Gains form of the PID algorithm. Changes to the proportional gain do not affect integral or derivative response.
7	Click to use the Dependent Gains form of the PID algorithm (default). Changes to Cfg_PGain are applied as loop gain changes and affect proportional, integral, and derivative responses.
8	Type a value for maximum deviation between SP and PV. If the deviation exceeds this value, the SP ramp pauses until the PV returns to a value within the set deviation.



## Engineering Tab Page 5

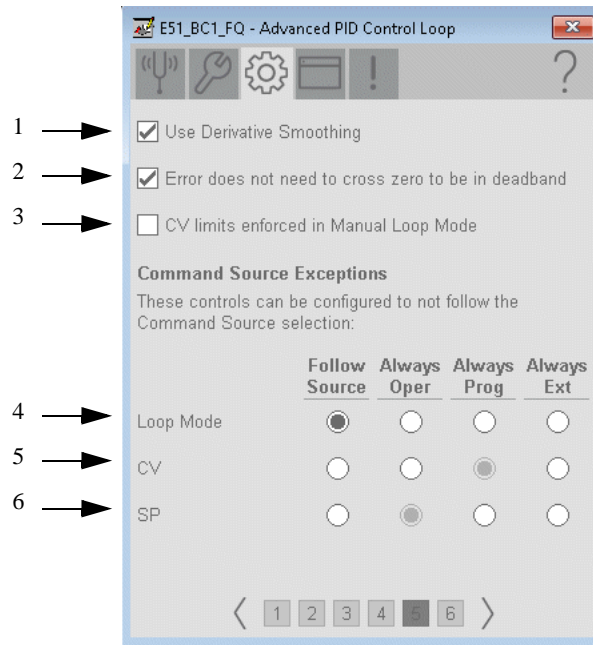


Table 128 - Engineering Tab Page 5 Description

Item	Description
1	Check to enable derivative smoothing. Derivative smoothing can help reduce output jitter due to noise on the PV signal. Clear this checkbox to disable derivative smoothing. When derivative smoothing is disabled, it can result in quicker loop response at high derivative gain.
2	Check to disable the zero-crossing function. Once the error is within the deadband, the output does not change, even if the sign of the error has not changed (error has not crossed zero).  Clear this checkbox to use the zero-crossing deadband. The error must change signs (cross zero) for the deadband function to be activated and stop changes to loop output.
3	Check to limit the CV to the range specified by Cfg_MinCV and Cfg_MaxCV when the Loop mode is Manual. Clear this checkbox to allow CV values anywhere in the 0.0%...100.0% range in Manual Loop mode.
4	Check to keep control of loop mode commands with the Operator, Program, External, or Follow the Source even if the instruction is in Program mode.
5	Check to keep control of the controlled variable quantity setting with the Operator, Program, External, or Follow the Source even if the instruction is in Program mode.
6	Check to keep control of the setpoint settings with the Operator, Program, External, or Follow the Source even if the instruction is in Program mode.
7	Check to keep control of the ratio settings with the Operator, Program, External, or Follow the Source even if the instruction is in Program mode.

Engineering Tab Page 6

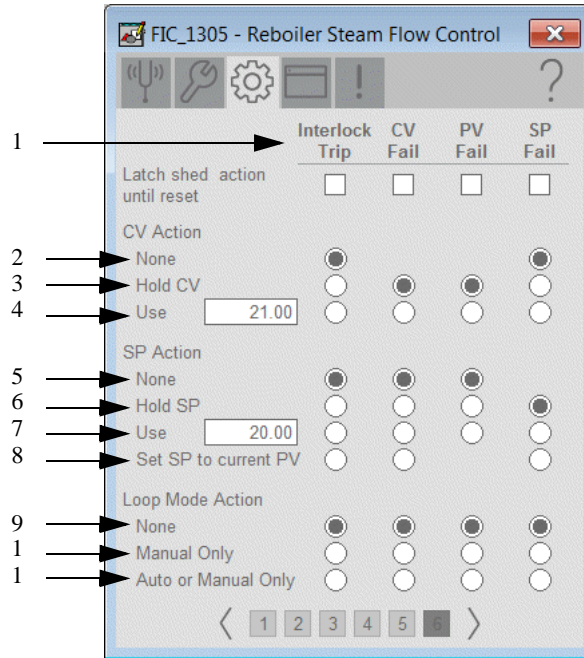


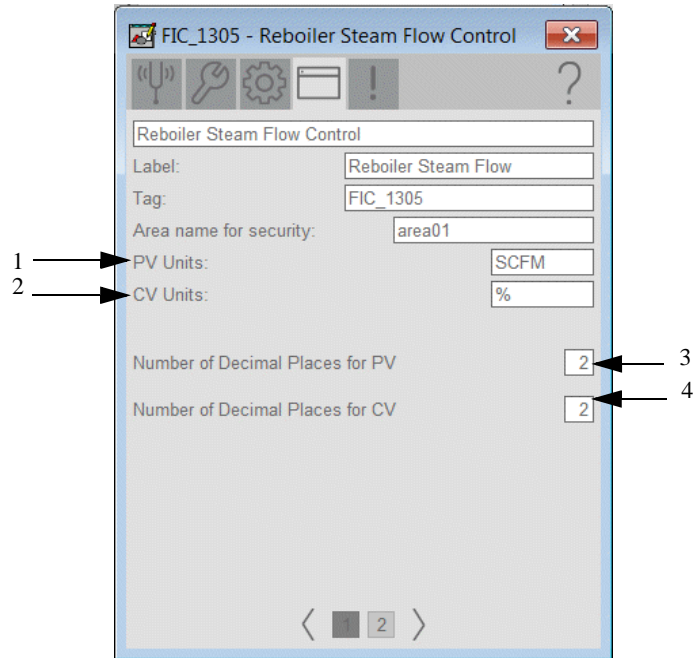
Table 129 - Engineering Tab Page 6 Description

Item	Description
1	Possible Failures
2	For the given failure, do not change the CV operation, keep controlling.
3	For the given failure, hold the CV at the current value.
4	For the given failure, set the CV to the configured value.
5	For the given failure, do not change the SP operation.
6	For the given failure, hold the SP at the current value.
7	For the given failure, set the SP to the configured value.
8	For the given failure, have SP track the current PV value.
9	For the given failure, keep current loop mode.
10	For the given failure, set the loop mode to manual.
11	For the given failure, If loop made is cascade set to auto.

**TIP** To have the loop mode return to the previous control operation when the failure clears, set Loop Mode Action to None.

*HMI Configuration Tab 1*

The HMI configuration tab provides access to displayed text, and faceplate-to-faceplate navigation settings. Configure the description, label, tag, and security area for the device. See [Basic Faceplate Attributes on page 32](#) for the description of the common attributes.

**Table 130 - HMI Configuration Tab 1 Description**

Item	Description
1	Type the PV engineering units for display on the HMI.
2	Type the CV engineering units for display on the HMI. Percent (%) is the default.
3	Type in the number of decimal places that are displayed for the Process Variable
4	Type in the number of decimal places that are displayed for the Control Variable

HMI Configuration Tab 2

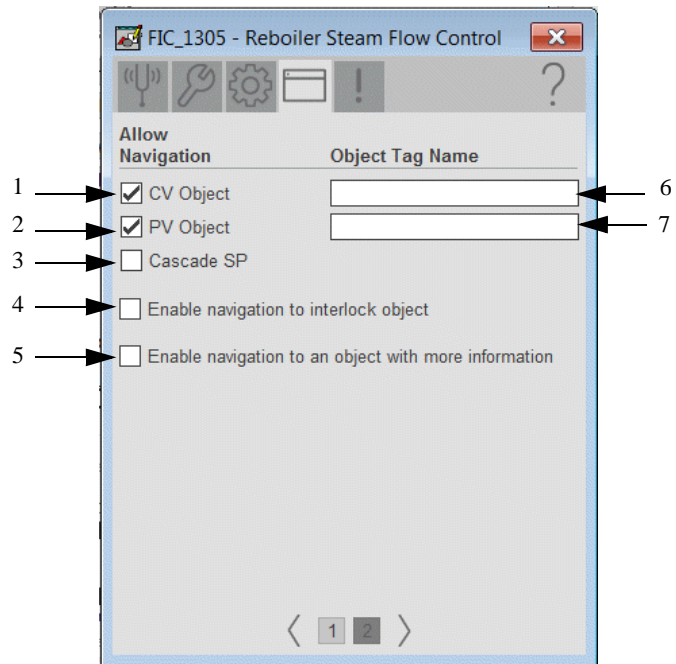
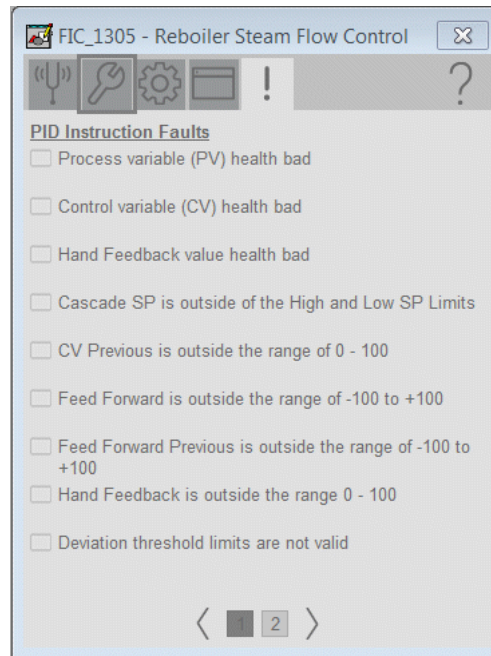


Table 131 - HMI Configuration Tab 2 Description

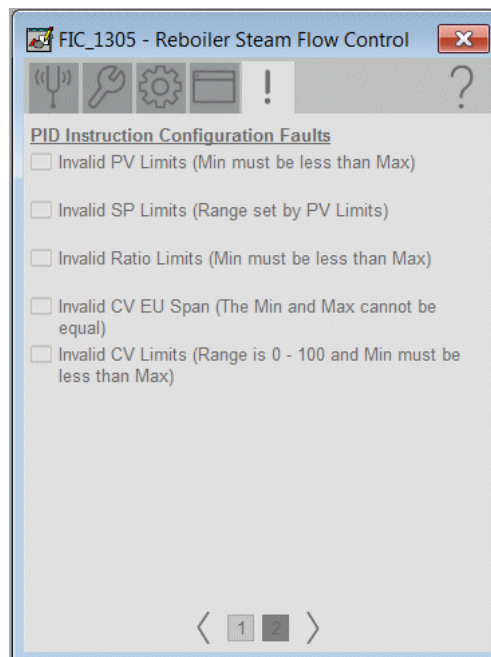
Item	Description
1	Check to enable navigation to the CV object.
2	Check to enable navigation to the PV object.
3	Check to enable navigation to Cascade SP object.
4	Check to enable navigation to the Interlock object.
5	Check to enable navigation to an object with more information (Cfg_HasMoreObj is set to true.) This can be configured to navigate to an AOI backing tag or a UDT tag that has HMI_Type and HMI_Lib defined. For example, there is a motor with the tag name P_101 and there is a need to have the more information button navigate to the parent P_LLS object. A tag is created for the P_LLS object that is given the alias P101_More. When the more information button is pressed on the motor, it links to P101_More. This will open the faceplate for the LLS object.
6	Type the name of the CV Object to navigate to.
7	Type the name of the PV Object to navigate to.

*Faults Tabs*

Page 1 of the Diagnostics tab displays PID Instruction faults.



Page 2 of the Diagnostics tab displays PID Instruction Configuration Faults.



## Diagnostics Tab

The Diagnostic tab provides indications that are helpful to diagnose or help prevent device problems. The device problems can include specific reasons a device is 'Not Ready', device warnings and faults, warning and fault history, and predictive/preventive maintenance data.

The Diagnostics tab displays possible reasons for the device not being ready. See [Diagnostics Tab on page 36](#)

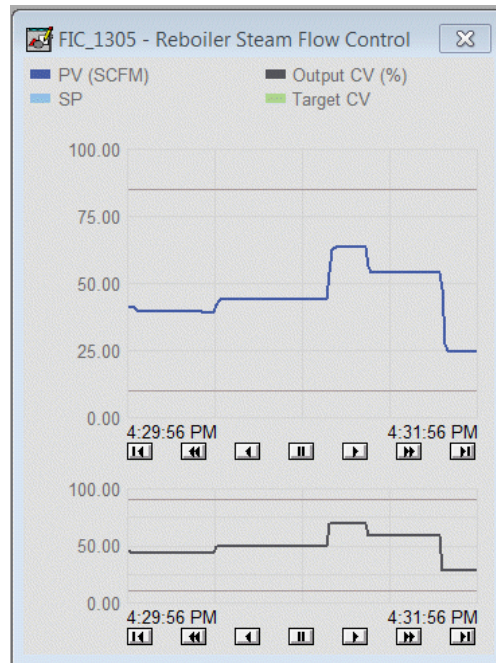
## Alarms Tab

The Alarms tab displays each configured alarm. The icon on the tab for the alarms page changes color to show the current active alarm status. A blinking alarm icon indicates that one or more alarms must be acknowledged or the device must be reset. See [Common Alarm Block \(P\\_Alarm\) on page 66](#) for more information.

## Trends

On the upper part of the Trends tab, you can view the SP (blue line) and PV (green line).

On the lower part of the Trends tab, you can view the Output CV (black line) and the Target CV (orange line).



## Analog Fanout (P\_Fanout)

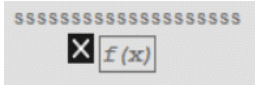
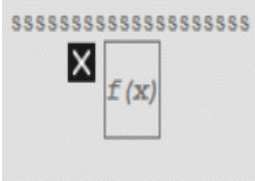
The Analog Fanout (P\_Fanout) Add-On Instruction fans one 'primary' analog output signal out to multiple 'secondary' users or devices. Each secondary output has configurable gain, offset, and clamping limits.

This document is for the visualization files, display elements, global objects, and HMI information. The operation of the Add-on Instructions and controller code is contained in publication [PROCES-RM013](#).

### Display Elements

A display element (global object) is created once and can be referenced multiple times on multiple displays in an application. When changes are made to the original (base) object, the instantiated copies (reference objects) are automatically updated. Use of global objects, with tag structures in the ControlLogix system, aid consistency and save engineering time.

**Table 132 - P\_Fanout Display Element Description**

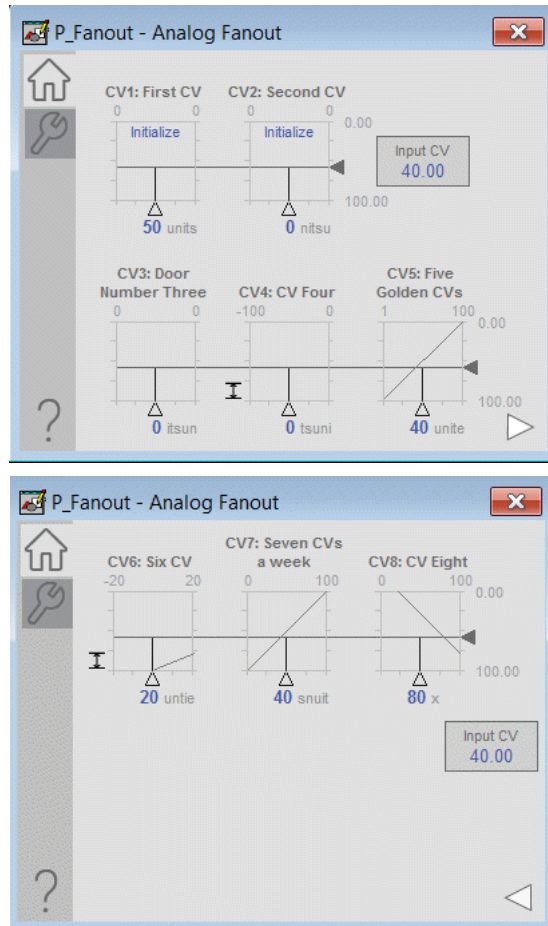
Display Element Name	Display Element	Description
GO_P_Fanout		P_Fanout global object (horizontal layout).
GO_P_Fanout1		P_Fanout global object (vertical layout).



## Operator Tab

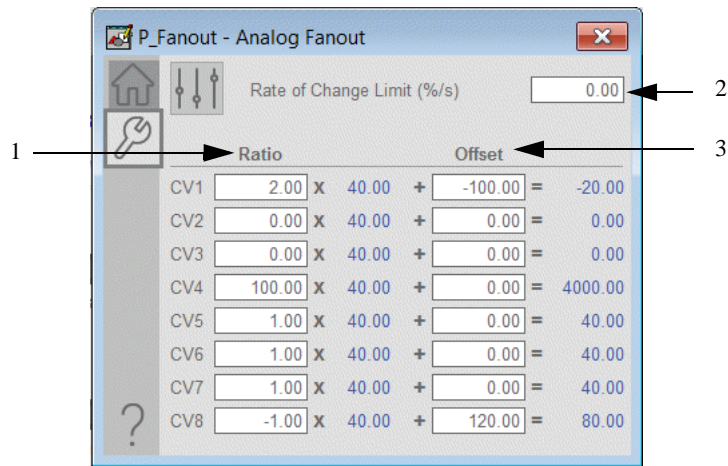
The Faceplate initially opens to the Operator (Home) tab. From here, an operator can monitor the device status and manually operate the device when it is in Operator mode. Several features are common to all Add-On Instructions faceplates. See [Basic Faceplate Attributes on page 32](#).

If outputs 6, 7, and 8 are used by the instruction (in other words, if Cfg\_HasCV6... Cfg\_HasCV8 are 1), the global object has a second page of the faceplate that displays the information.



## Maintenance Tab

Maintenance personnel use the information and controls on the Maintenance tab to adjust device parameters, troubleshoot, temporarily work around device problems, and disable the device for routine maintenance. Several features are common to all Add-On Instructions faceplates. See [Basic Faceplate Attributes on page 32](#)



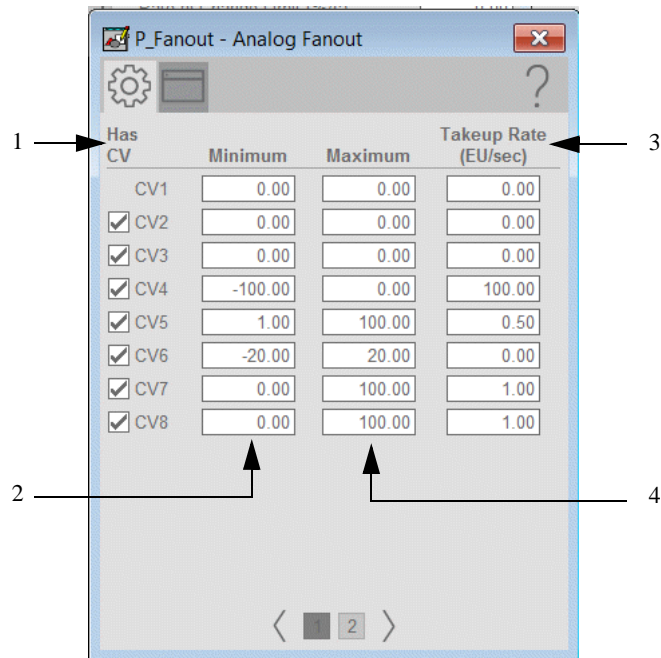
**Table 133 - Maintenance Tab Description**

Item	Description
1	Type a value that sets the ratio to calculate each individual output. This value either sets the operator ratio (for example, OSet_CV1Ratio) or the configuration ratio (for example, Cfg_CV1Ratio) depending on the ratio source selection.
2	Type a value that sets the offset to calculate each individual output. This value either sets the operator offset (for example, OSet_CV1Offset) or the configuration offset (for example, Cfg_CV1Offset) depending on the ratio source selection.
3	Operator setting for the Input CV rate of change limit (increasing or decreasing). If Cfg_MaxCVRoC = 0.0, then this parameter can be set to zero, which means the rate of change is not limited.

## Advanced Properties Display

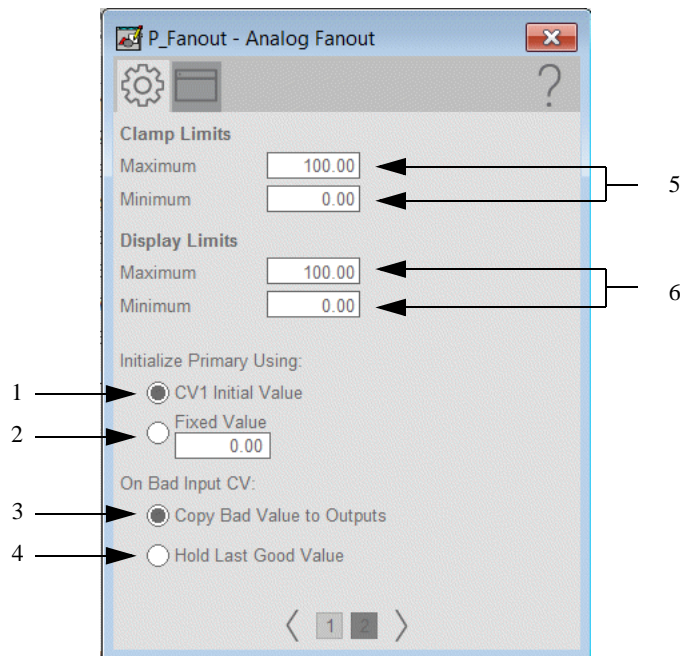
The Advanced Properties Display opens to the engineering settings. The Advanced Properties Display provides access to device configuration parameters and ranges, and options for device and I/O setup. This tab is used for initial system commissioning or later system changes.

### Engineering Tab



**Table 134 - Engineering Tab Page 1 Description**

Item	Description
1	Check to enable use of the corresponding output.
2	Type a value for the minimum value to be used to clamp CV (in engineering units).
3	Type a rate the CV is to change to a calculated value after initialization to provide bumpless transfer from initialization.
4	Type a value for the maximum value to be used to clamp CV (in engineering units).

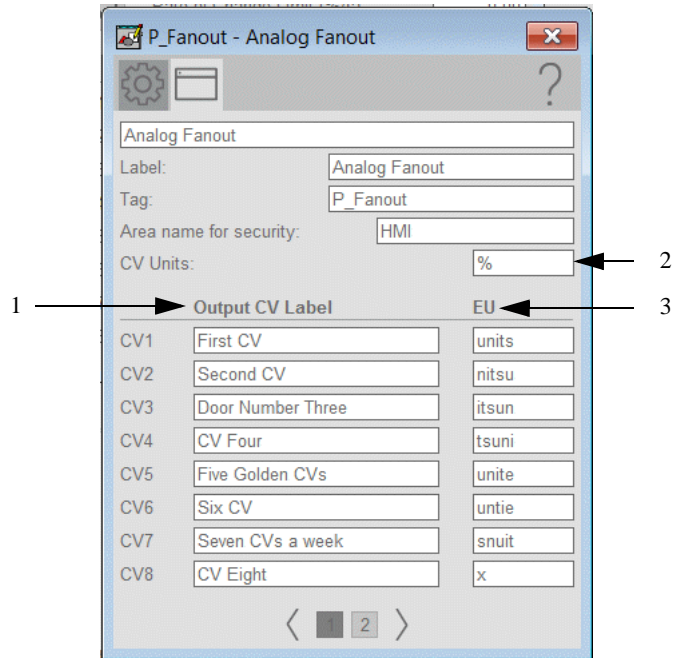


**Table 135 - Engineering Tab Page 2 Description**

Item	Description
1	Click to use the CV1 initialization value (Inp_CV1InitVal) to set the initialization output (Out_CV_InitVal) when initialization is requested.
2	Click to use a fixed value (Cfg_FixedInitVal) to set the initialization output (Out_CV_InitVal) when initialization is requested. Type a value to set the initialization value (Out_CVInitVal) if initialization is requested and a fixed value option is selected.
3	Click to hold last good value.
4	Click to pass through the bad value.
5	Type values to set the limits to use to clamp the CV.
6	Type values to set the limits to display for the CV.

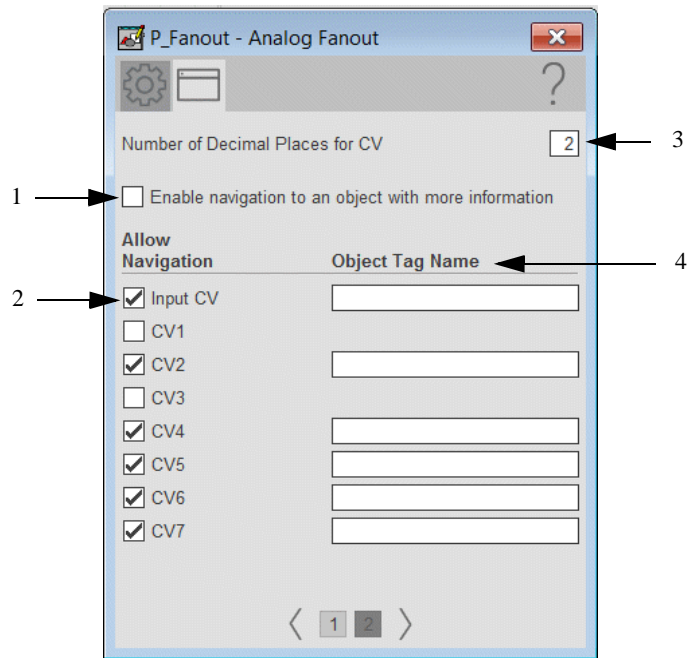
### HMI Configuration Tab

The HMI configuration tab provides access to displayed text, and faceplate-to-faceplate navigation settings. Configure the description, label, tag, and security area for the device. See [Basic Faceplate Attributes on page 32](#) for the description of the common attributes.



**Table 136 - HMI Configuration Tab Page 1 Description**

Item	Description
1	Type the description of the output name.
2	Type the units that are used with the CV.
3	Sets the CV engineering units to use for display.



**Table 137 - HMI Configuration Tab Page 2 Description**

Item	Description
1	<p>Check to enable navigation to an object with more information (Cfg_HasMoreObj is set to true.)</p> <p>This can be configured to navigate to an AOI backing tag or a UDT tag that has HMI_Type and HMI_Lib defined.</p> <p>For example, there is a motor with the tag name P_101 and there is a need to have the more information button navigate to the parent P_LLS object. A tag is created for the P_LLS object that is given the alias P101_More. When the more information button is pressed on the motor, it links to P101_More. This will open the faceplate for the LLS object.</p>
2	<p>Check to permit navigation to a faceplate for which you typed a tag name. For example, 'MyCVObject'.</p>
3	<p>Type the number of decimal places to be shown for CV.</p>
4	<p>Type the text that is displayed on the HMI.</p>

## **Diagnostics Tab**

The Diagnostic tab provides indications that are helpful to diagnose or help prevent device problems. The device problems can include specific reasons a device is 'Not Ready', device warnings and faults, warning and fault history, and predictive/preventive maintenance data.

The Diagnostics tab displays possible reasons for the device not being ready. See [Diagnostics Tab on page 36](#)

## **Alarms Tab**

The Alarms tab displays each configured alarm. The icon on the tab for the alarms page changes color to show the current active alarm status. A blinking alarm icon indicates that one or more alarms must be acknowledged or the device must be reset. See [Common Alarm Block \(P\\_Alarm\) on page 66](#) for more information.

## High or Low Selector (P\_HiLoSel)

The P\_HiLoSel (High or Low Selector Add-On Instruction) selects the lowest of the (up to six) incoming CVs (if Cfg\_HiLoSel = 0), or the highest of the incoming CVs (if Cfg\_HiLoSel = 1) and outputs it (Out\_CV).

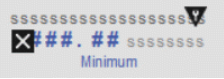
The unselected CVs are flagged to track the selected CV.

This document is for the visualization files, display elements, global objects, and HMI information. The operation of the Add-on Instructions and controller code is contained in publication [PROCES-RM013](#).

### Display Elements

A display element (global object) is created once and can be referenced multiple times on multiple displays in an application. When changes are made to the original (base) object, the instantiated copies (reference objects) are automatically updated. Use of global objects, with tag structures in the ControlLogix system, aid consistency and save engineering time.

**Table 138 - P\_HiLoSel Display Elements Description**

Display Element Name	Display Element	Description
P_HiLoSel		Standard High or Low Selector global object.

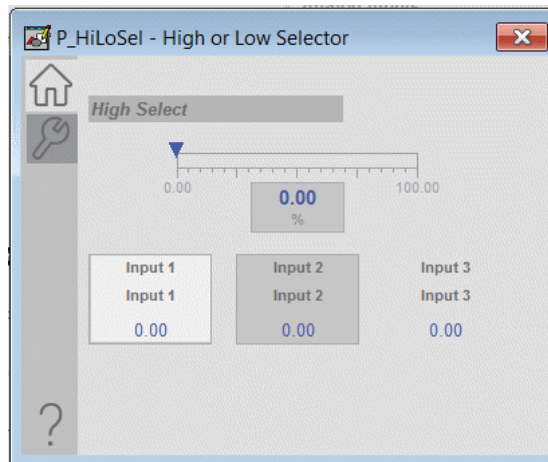


## Operator Tab

The Faceplate initially opens to the Operator (Home) tab. From here, an operator can monitor the device status and manually operate the device when it is in Operator mode. Several features are common to all Add-On Instructions faceplates. See [Basic Faceplate Attributes on page 32](#).

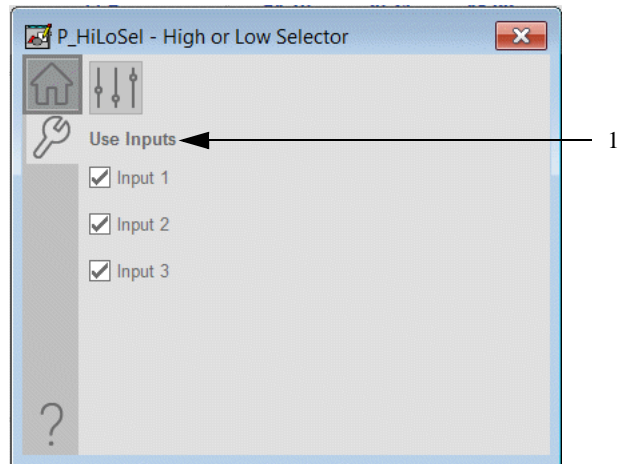
The Operator tab shows the following information:

- Current operation (High or Low Select)
- Currently selected input (white highlight)
- Bar graph for clamp limits from minimum to maximum plus Output CV indicator
- Input CV values and Output CV value



## Maintenance Tab

Maintenance personnel use the information and controls on the Maintenance tab to adjust device parameters, troubleshoot, temporarily work around device problems, and disable the device for routine maintenance. Several features are common to all Add-On Instructions faceplates. See [Basic Faceplate Attributes on page 32](#)



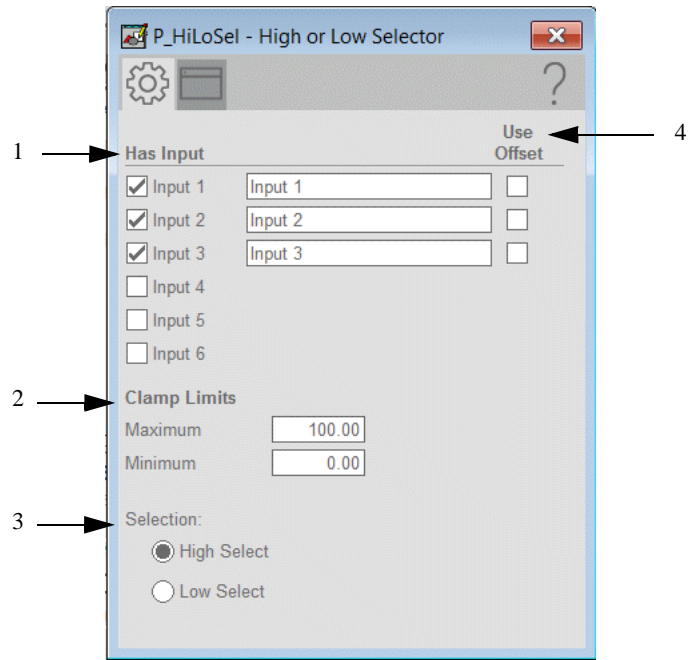
**Table 139 - Maintenance Tab Description**

Item	Description
1	Check to use a CV input. Clear a checkbox not to use the input and put the instruction in Maintenance Bypass.

## Advanced Properties Display

The Advanced Properties Display opens to the engineering settings. The Advanced Properties Display provides access to device configuration parameters and ranges, and options for device and I/O setup. This tab is used for initial system commissioning or later system changes.

### Engineering Tab

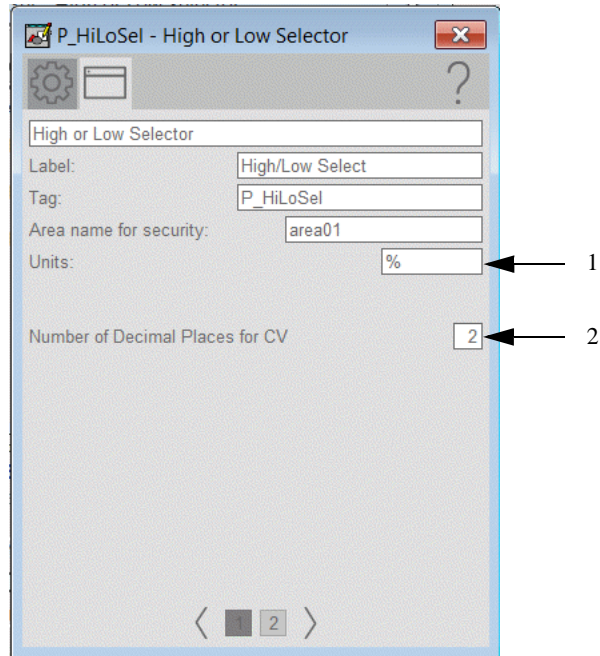


**Table 140 - Engineering Tab Description**

Item	Description
1	Check 'Has Input' (CV1...CV6) where an input is connected.
2	Type in the minimum and maximum to set the range for the selected input CV. If the selected input CV is below the minimum, it is clamped to the minimum value. If the selected input CV is above the maximum, it is clamped to the maximum value.
3	Click High Select to select the highest input CV value to pass to the output. Click Low Select to select the lowest input CV value to pass to the output.
4	Check a 'Use Offset' (CV1...CV6) to include the $K_p * E$ offset in initialization calculation.

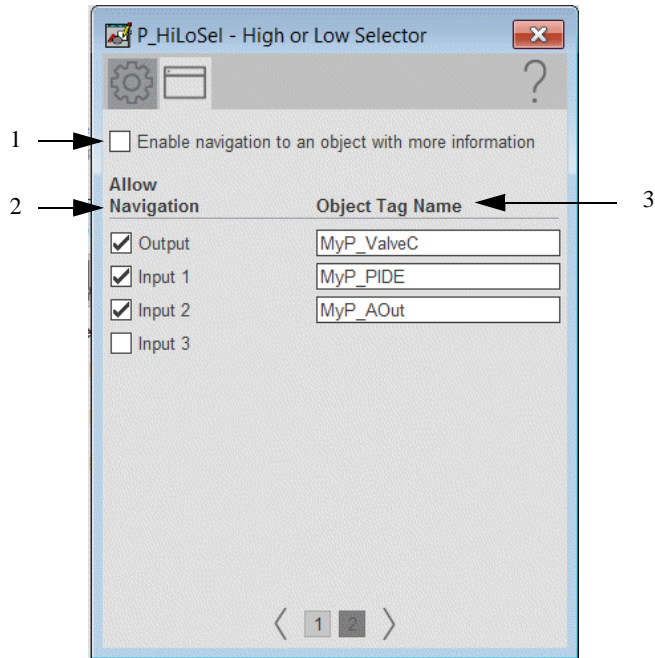
### HMI Configuration Tab

The HMI configuration tab provides access to displayed text, and faceplate-to-faceplate navigation settings. Configure the description, label, tag, and security area for the device. See [Basic Faceplate Attributes on page 32](#) for the description of the common attributes.



**Table 141 - HMI Configuration Tab Page 1 Description**

Item	Description
1	Type the engineering units for display on the HMI. Percent (%) is the default.
2	Type in the number of decimal places that are displayed for the CV.

**Table 142 - HMI Configuration Tab Page 2 Description**

Item	Description
1	<p>Check to enable navigation to an object with more information (Cfg_HasMoreObj is set to true.)</p> <p>This can be configured to navigate to an AOI backing tag or a UDT tag that has HMI_Type and HMI_Lib defined.</p> <p>For example, there is a motor with the tag name P_101 and there is a need to have the more information button navigate to the parent P_LLS object. A tag is created for the P_LLS object that is given the alias P101_More. When the more information button is pressed on the motor, it links to P101_More. This will open the faceplate for the LLS object.</p>
2	<p>Check an input (CV1...CV6) or the Output CV to allow navigation to a specified object.</p>
3	<p>Type the tag name for the corresponding input (CV1...CV6) or Output CV.</p>

## Diagnostics Tab

The Diagnostic tab provides indications that are helpful to diagnose or help prevent device problems. The device problems can include specific reasons a device is 'Not Ready', device warnings and faults, warning and fault history, and predictive/preventive maintenance data.

The Diagnostics tab displays possible reasons for the device not being ready. See [Diagnostics Tab on page 36](#)

## Alarms Tab

The Alarms tab displays each configured alarm. The icon on the tab for the alarms page changes color to show the current active alarm status. A blinking alarm icon indicates that one or more alarms must be acknowledged or the device must be reset. See [Common Alarm Block \(P\\_Alarm\) on page 66](#) for more information.

## Deadband Controller (P\_DBC)


The P\_DBC (Deadband Controller) Add-On Instruction provides control of a process variable within limits by using one or two discrete outputs. A deadband controller is also known as a 'bang-bang' or 'on-off' controller.

This document is for the visualization files, display elements, global objects, and HMI information. The operation of the Add-on Instructions and controller code is contained in publication [PROCES-RM013](#).

### Display Elements

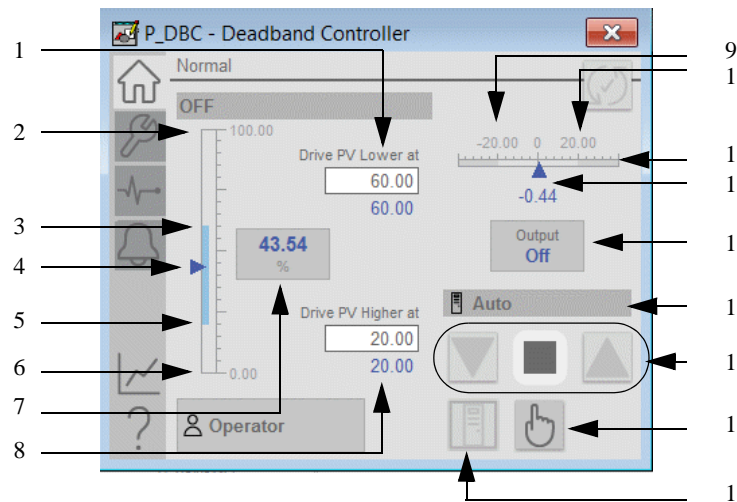
A display element (global object) is created once and can be referenced multiple times on multiple displays in an application. When changes are made to the original (base) object, the instantiated copies (reference objects) are automatically updated. Use of global objects, with tag structures in the ControlLogix system, aids consistency and saves engineering time.

**Table 143 - P\_DBC Global Object Loop Symbol**

Global Object Name	Global Object	Description
GO_P_DBC		Standard deadband controller global object.

## Operator Tab

The Faceplate initially opens to the Operator (Home) tab. From here, an operator can monitor the device status and manually operate the device when it is in Operator mode. Several features are common to all Add-On Instructions faceplates. See [Basic Faceplate Attributes on page 32](#).



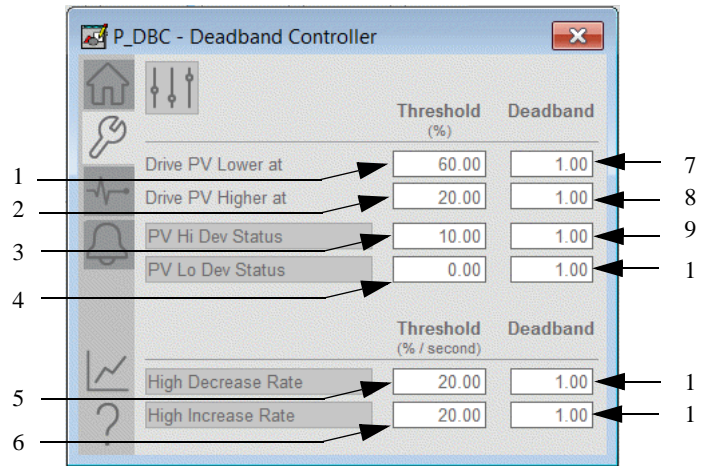
**Table 144 - Operator Tab Description**

Item	Description
1	Drive PV Lower Limit
2	PV EU maximum
3	Drive PV Lower Value
4	Current PV Value
5	Drive PV Higher Value
6	PV EU minimum
7	Current PV Value
8	Drive PV Higher Limit
9	High Rate of Change Decreasing Limit
10	High Rate of Change Increasing Limit
11	Rate of Change Indicator
12	Current Rate of Change
13	Controlled Variable Indicator
14	Auto/Manual Mode Indicator
15	Drive PV buttons. From left to right: drive PV lower, don't drive PV, drive PV higher
16	Manual Mode Command Button
17	Auto Mode Command Button



## Maintenance Tab

Maintenance personnel use the information and controls on the Maintenance tab to adjust device parameters, troubleshoot, temporarily work around device problems, and disable the device for routine maintenance. Several features are common to all Add-On Instructions faceplates. See [Basic Faceplate Attributes on page 32](#)



**Table 145 - Maintenance Tab Description**

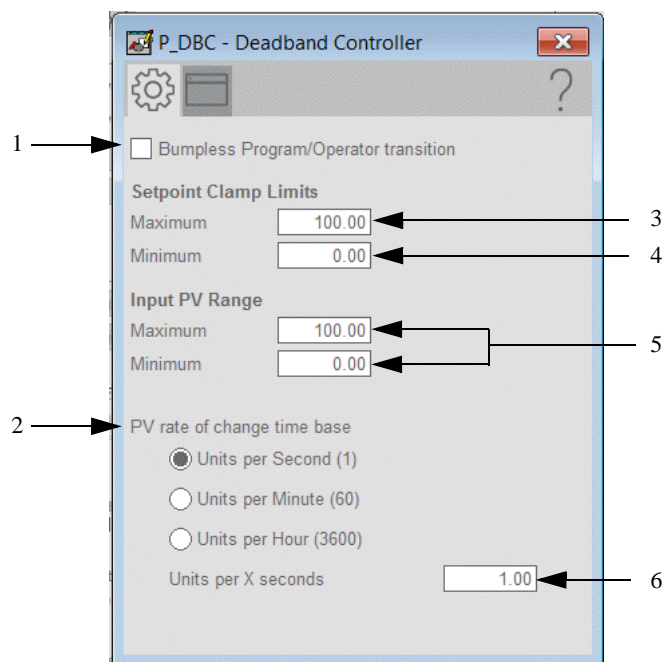
Item	Description
1	Enter the value of the PV at which the output turns off and PV starts to decrease.
2	Enter the value of the PV at which the output turns on and PV starts to increase.
3	Type the number that is used to establish the high deviation limit. When the PV reaches this limit, a High Deviation alarm is generated. <b>EXAMPLE:</b> In the examples, the Lower setpoint is 67 and the PV Hi Dev Status is 5. We add 67 and 5 to get the high deviation limit of 72.
4	Type the number that is used to establish the low deviation limit. When the PV reaches this limit, a Low Deviation alarm is generated. <b>EXAMPLE:</b> In the examples, the Raise setpoint is 30 and the PV Lo Dev Status is -5. We add 30 and -5 to get the low deviation limit of 25.
5	Type the number to set the high Rate of Change (decrease) limit (83 in the example). When the Rate of Change reaches this level, a Hi Rate of Decrease alarm is generated.
6	Type the number to set the high Rate of Change (increase) limit (17 in the example). When the Rate of Change reaches this level, a Hi Rate of Increase alarm is generated.
7	Type a number that is the size of the deadband for the Lower output (below Lower limit)
8	Type a number that is the size of the deadband for the Raise output (above Raise limit)

Item	Description
9	Type the number that PV must decrease to reset a High Deviation alarm. <b>EXAMPLE:</b> The high deviation limit is 72 and the deadband is 1. The PV must decrease 1 unit to 71 to reset the High Deviation alarm. <b>IMPORTANT:</b> The deadband can be set so that the PV must decrease below the Lower setpoint before the High Deviation alarm is reset. For example, the deadband can be set to 10 so that the PV must decrease to 62 to reset the alarm.
10	Type the number that PV must increase to reset a Low Deviation alarm. <b>EXAMPLE:</b> The low deviation limit is 30 and the deadband is 1. The PV must increase 1 unit to 26 to reset the Low Deviation alarm. <b>IMPORTANT:</b> The deadband can be set so that the PV must increase above the Raise setpoint before the Low Deviation alarm is reset. For example, the deadband can be set to 10 so that the PV must decrease to 35 to reset the alarm.
11	Type the number that the Rate of Change must decrease to reset a Hi Rate of Decrease alarm.
12	Type the number that the Rate of Change must increase to reset a Hi Rate of Increase alarm.

## Advanced Properties Display

The Advanced Properties Display opens to the engineering settings. The Advanced Properties Display provides access to device configuration parameters and ranges, and options for device and I/O setup. This tab is used for initial system commissioning or later system changes.

### Engineering Tab

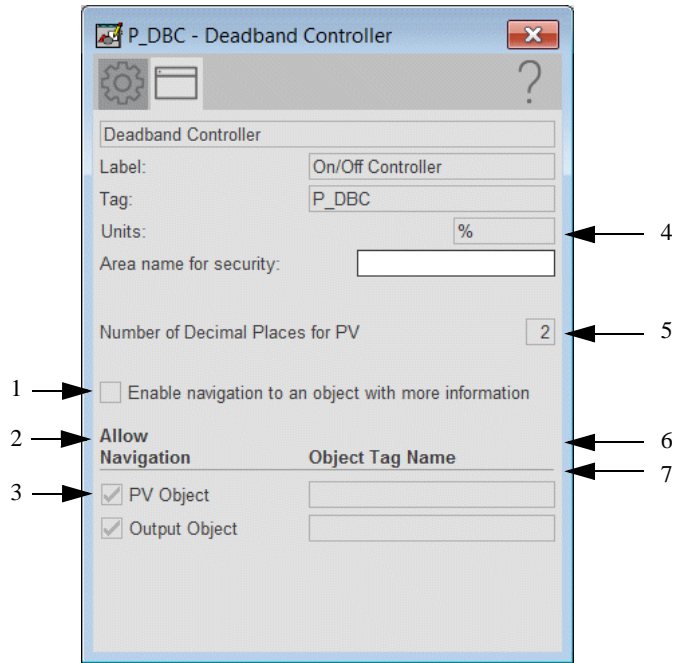


**Table 146 - Engineering Tab Description**

Item	Description
1	<p>Check, the operator settings track the program settings when mode is Program, and program settings track the operator settings when the mode is Operator. Transition between modes is bumpless.</p> <p>Clear the checkbox, this instruction does not modify the operator settings and program settings. The operator settings and program settings retain their values regardless of mode. When the mode is changed, the value of a limit can change, such as from the Program-set value to the Operator-set value.</p>
2	Click the PV rate of change time base used.
3	Type the lower limit for the Loop PV Higher point.
4	Type the upper limit for the loop PV Lower point.
5	<p>Minimum and maximum values for PV input.</p> <p>These values are reflected on the PV bar graph on the Operator tab and the graph on the Trends tab.</p>
6	Type the number of units per x seconds, where x equals the number of seconds selected for the PV rate of change time base.

### HMI Configuration Tab

The HMI configuration tab provides access to displayed text, and faceplate-to-faceplate navigation settings. Configure the description, label, tag, and security area for the device. See [Basic Faceplate Attributes on page 32](#) for the description of the common attributes.



**Table 147 - HMI Configuration Tab Description**

Item	Description
1	Check to enable navigation to an object with more information (Cfg_HasMoreObj is set to true.) This can be configured to navigate to an AOI backing tag or a UDT tag that has HMI_Type and HMI_Lib defined. For example, there is a motor with the tag name P_101 and there is a need to have the more information button navigate to the parent P_LLS object. A tag is created for the P_LLS object that is given the alias P101_More. When the more information button is pressed on the motor, it links to P101_More. This will open the faceplate for the LLS object.
2	Check to enable navigation to the PV object.
3	Check to enable navigation to the Output object.
4	Type the text of the engineering units for the PV.
5	Type the number of decimal places that are used for the PV.
6	Type the name of the PV object to navigate to.
7	Type the name of the Output object to navigate to.

## **Diagnostics Tab**

The Diagnostic tab provides indications that are helpful to diagnose or help prevent device problems. The device problems can include specific reasons a device is 'Not Ready', device warnings and faults, warning and fault history, and predictive/preventive maintenance data.

The Diagnostics tab displays possible reasons for the device not being ready. See [Diagnostics Tab on page 36](#)

## **Alarms Tab**

The Alarms tab displays each configured alarm. The icon on the tab for the alarms page changes color to show the current active alarm status. A blinking alarm icon indicates that one or more alarms must be acknowledged or the device must be reset. See [Common Alarm Block \(P\\_Alarm\) on page 66](#) for more information.

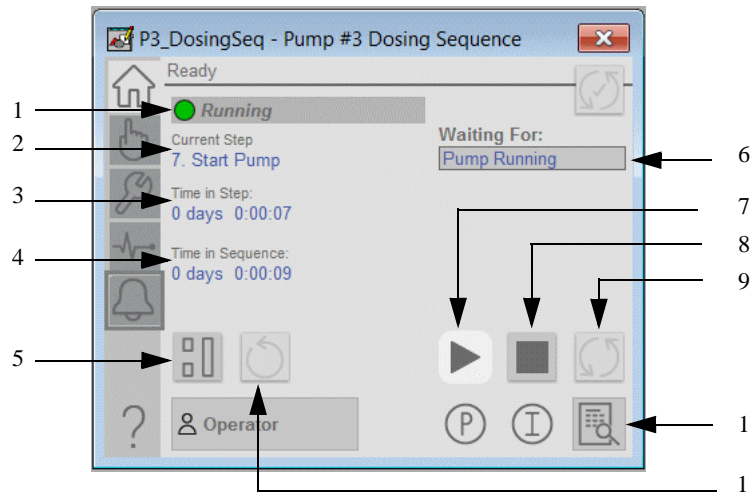
## Rockwell Automation Sequencer Object (P\_Seq)

The Rockwell Automation® Sequencer Object (P\_Seq) provides a flexible controller-based step sequencing solution that reduces engineering time by automating common operator procedures. The step-by-step configuration makes it easy to adjust procedures directly from the HMI displays without having to create or modify custom code in the controller. The Sequencer can be employed in simple and complex sequences without costly tests and re-engineering. You add, delete, or modify steps that are required accomplish the objective of the sequence.

This document is for the visualization files, display elements, global objects, and HMI information. The operation of the Add-on Instructions and controller code is contained in publication [PROCES-RM013](#).

### Operator Tab

The Faceplate initially opens to the Operator (Home) tab. From here, an operator can monitor the device status and manually operate the device when it is in Operator mode. Several features are common to all Add-On Instructions faceplates. See [Basic Faceplate Attributes on page 32](#).



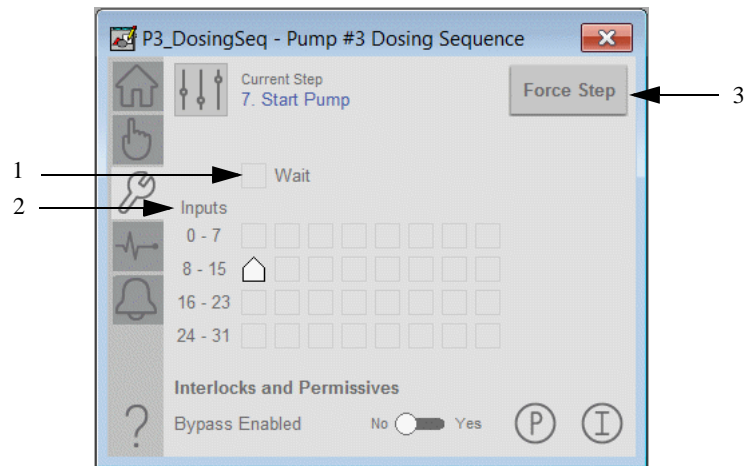
**Table 148 - Operator Tab Description**

Item	Description
1	Displays the current sequence state.
2	Displays the current step.
3	Displays the time in current step.
4	Displays the time in current sequence.
5	Click to hold the sequence.
6	Displays the step number, name, time, and the conditions that the sequence is waiting to qualify.
7	Click to start a sequence.

Item	Description
8	Click to stop a sequence.
9	Click to reset a sequence.
10	Click to display the runtime sequence window.
11	Click to restart a sequence.

## Maintenance Tab

Maintenance personnel use the information and controls on the Maintenance tab to adjust device parameters, troubleshoot, temporarily work around device problems, and disable the device for routine maintenance. Several features are common to all Add-On Instructions faceplates. See [Basic Faceplate Attributes on page 32](#)



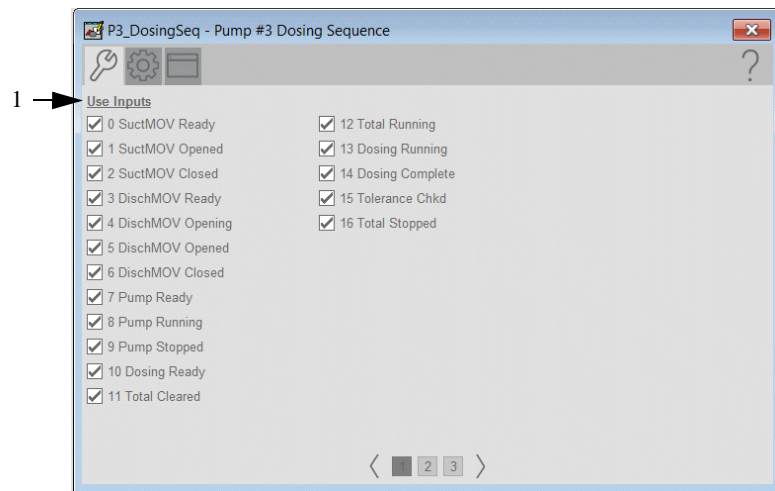
**Table 149 - Maintenance Tab Description**

Item	Description
1	Displays an indicator if there is an active wait in the current step.
2	Displays the inputs per the current step of the sequence. Inputs 0...31.
3	Click to force step complete.

## Advanced Properties Display

The Advanced Properties Display opens to the Advanced Maintenance settings. The Advanced Properties Display provides access to device configuration parameters and ranges, and options for device and I/O setup. This tab is used for initial system commissioning or later system changes.

### Advanced Maintenance Tab



**Table 150 - Advanced Maintenance Tab Page 1 Description**

Item	Description
1	All inputs are available for use and are checked. Each input is qualified as part of the step. Clear an input if there is a maintenance issue with the input. All steps then ignore the input and it is not used for qualification. The Sequencer goes into Maintenance Bypass.



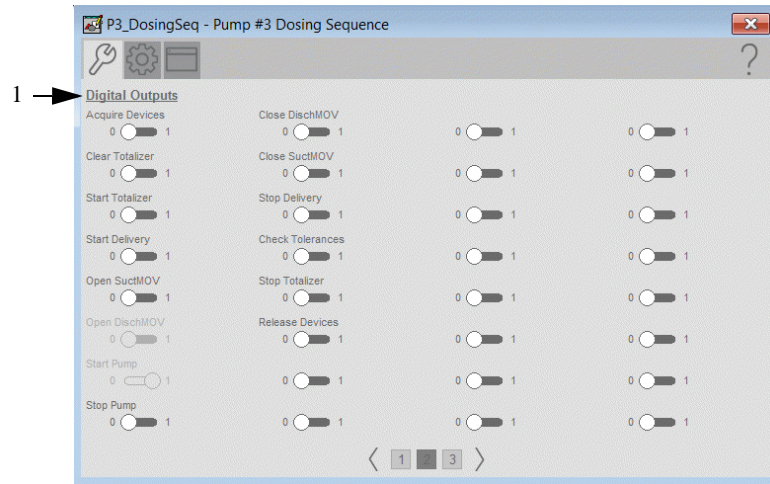
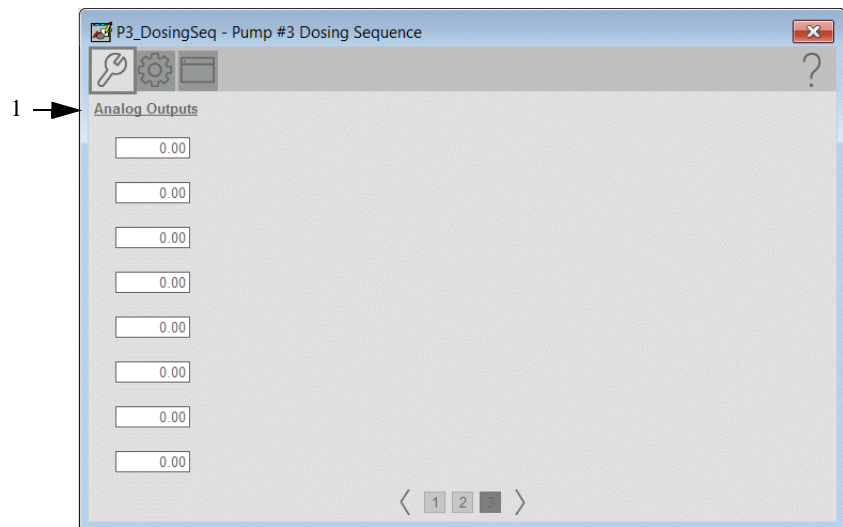


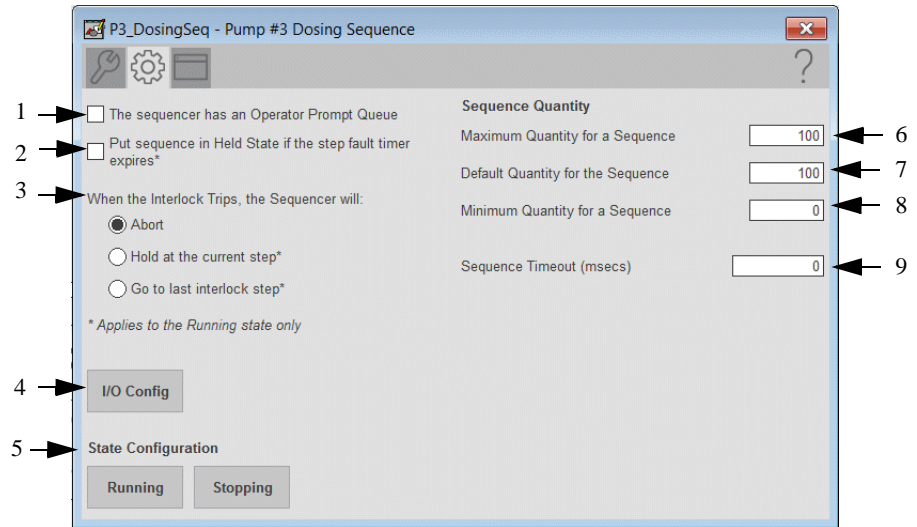
Table 151 - Advanced Maintenance Tab Page 2 Description

Item	Description
1	<p>Click to toggle the given output.</p> <p>An output cannot be toggled if:</p> <ul style="list-style-type: none"> <li>• It's actively driven by the sequence</li> <li>• Track Input is enabled for that input (black numbers)</li> </ul> <p>A dark gray slider is an indication of the 'Off' state (0).  A white slider is an indication of the 'On' state (1).</p> <p><b>IMPORTANT:</b> Maintenance personnel can manipulate the output directly from this tab if 'Track Input' on the Discrete Output Configuration page is turned off for a particular output AND (the current Sequencer step is not using a particular output OR the sequence is in a Held state).</p>



**Table 152 - Advanced Maintenance Tab Page 3 Description**

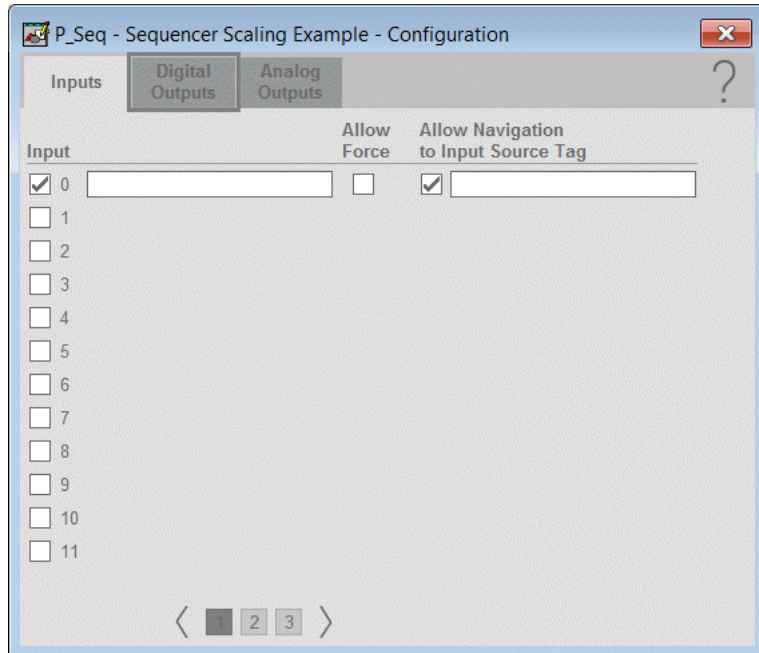
Item	Description
1	Type a setpoint or value for the analog outputs that are configured for the Sequencer. Outputs that are being actively driven by the sequence cannot be written. These outputs are unavailable. <b>IMPORTANT:</b> An output can be written only if 'Track Input' on the Analog Output Configuration page for that particular output is turn off.

*Engineering Tab***Table 153 - Engineering Tab Description**

Item	Description
1	Check to enable the manual prompt queue.
2	Check to put the sequence in a Held State if the step timer expires.
3	Check the box to indicate the Sequencer action when an interlock trips.
4	Click the Display Sequence Configuration Window button to access the Discrete Inputs, Discrete Outputs, and Analog Outputs configuration dialog boxes.
5	Click to configure either the Running State or the Stopping State.
6	Type a maximum value for a quantity.
7	Type a default quantity for a sequence.
8	Type a minimum value for a quantity.
9	Type a time in milliseconds that the sequence must be complete or a timeout occurs.

There are faceplates that open from the engineering tab that enable input and output configuration and configuration of both individual and multiple steps. The following figures show examples of those configuration faceplates.

**Figure 15 - I/O Configuration Inputs**



**Figure 16 - I/O Configuration Digital Outputs**

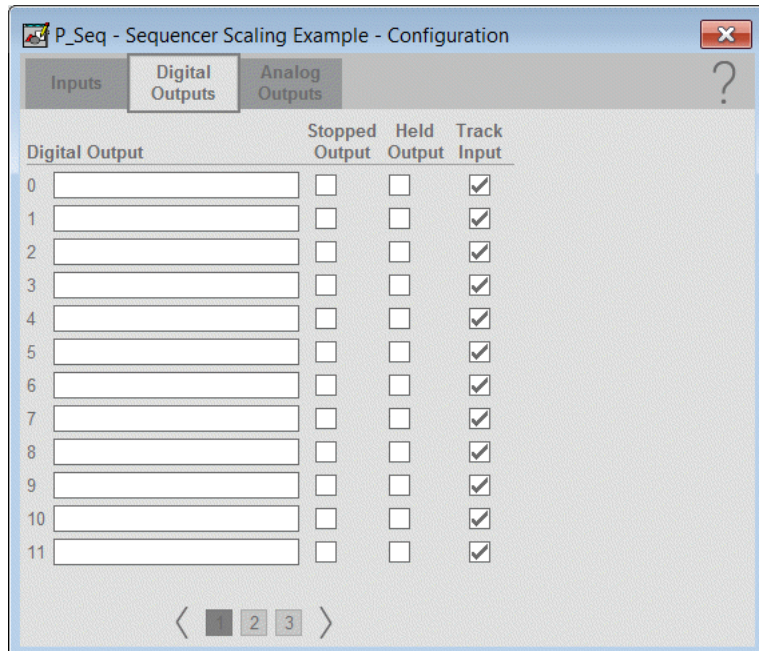


Figure 17 - I/O Configuration Analog Outputs

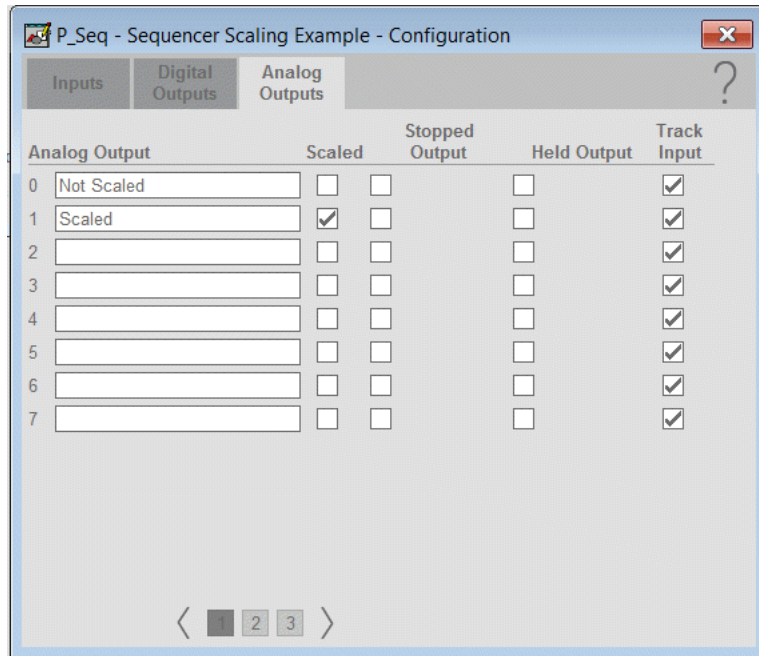


Figure 18 - State Configuration

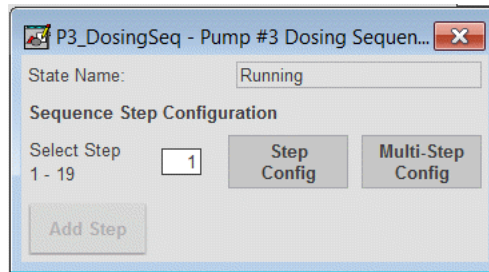
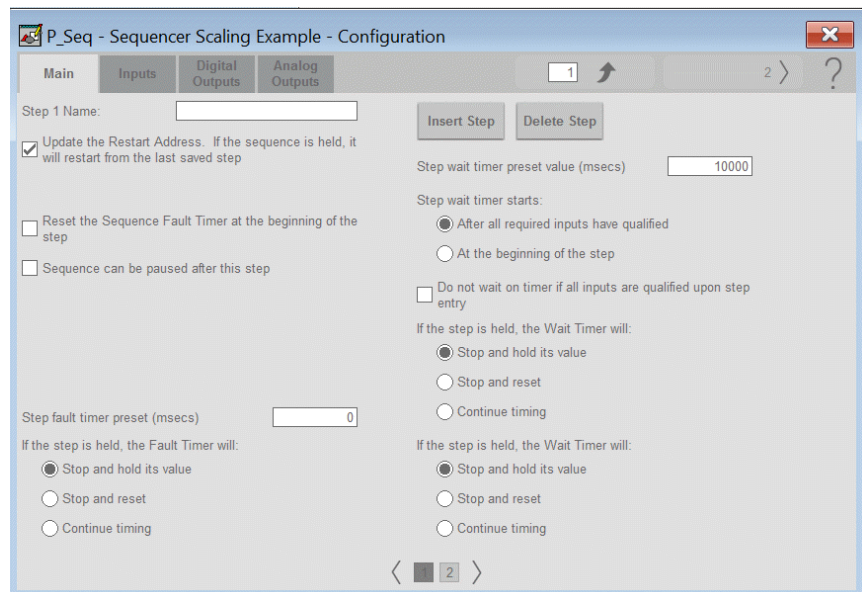
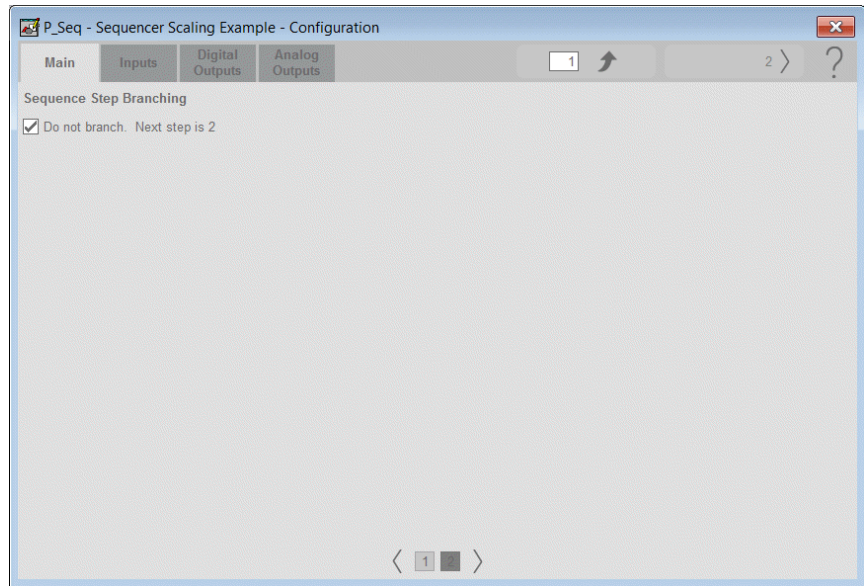


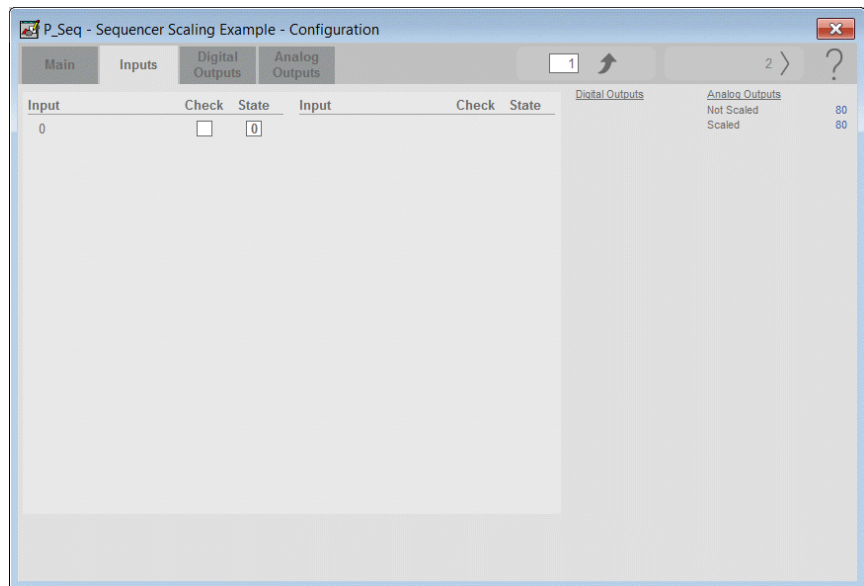
Figure 19 - Single Step Configuration Page 1



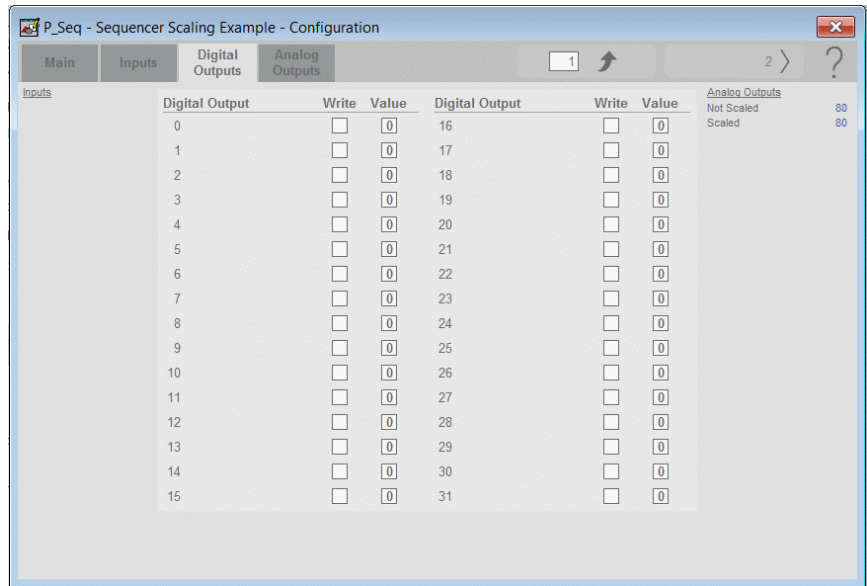
**Figure 20 - Single Step Configuration Page 2**



**Figure 21 - Single Step Configuration Inputs**



**Figure 22 - Single Step Configurations Digital Outputs**



**Figure 23 - Single Step Configurations Analog Outputs**

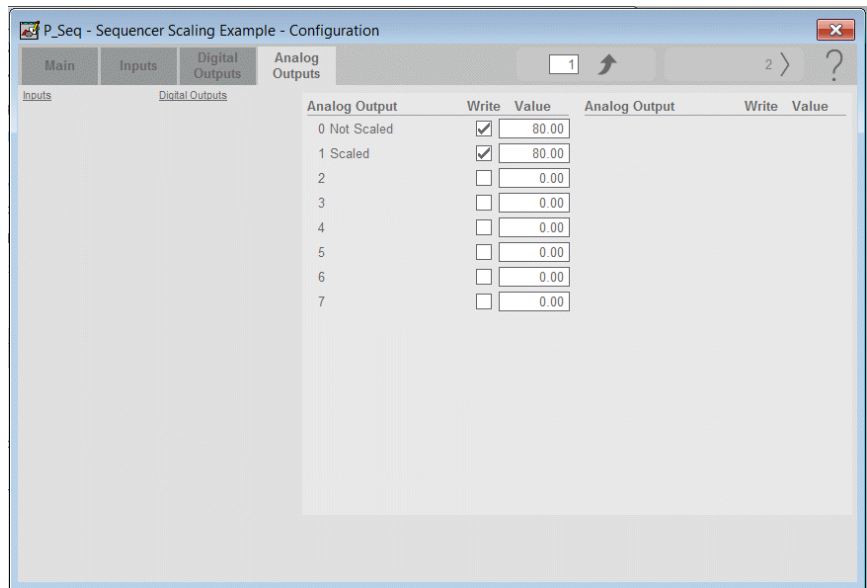


Figure 24 - Multiple Step Configuration

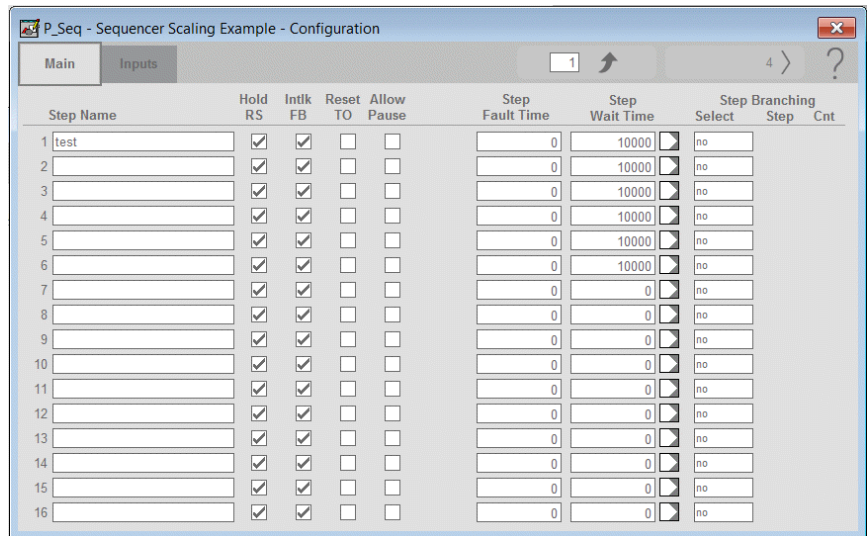
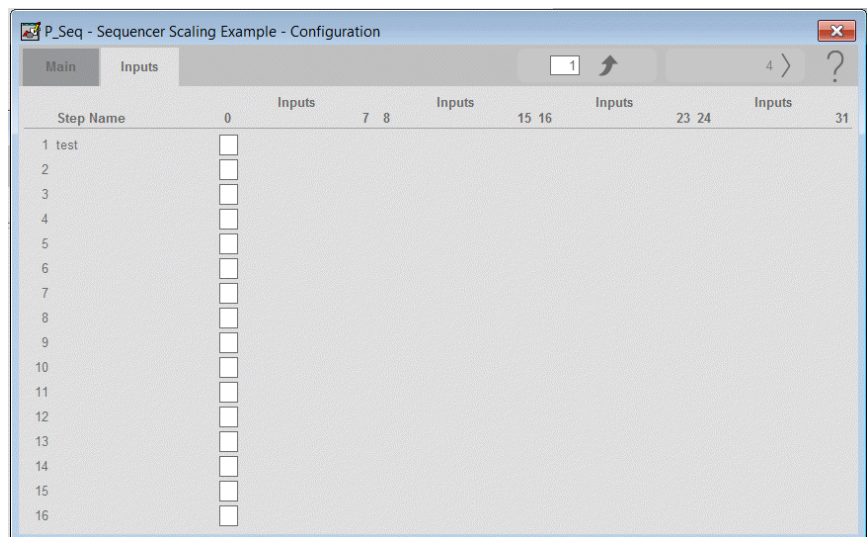


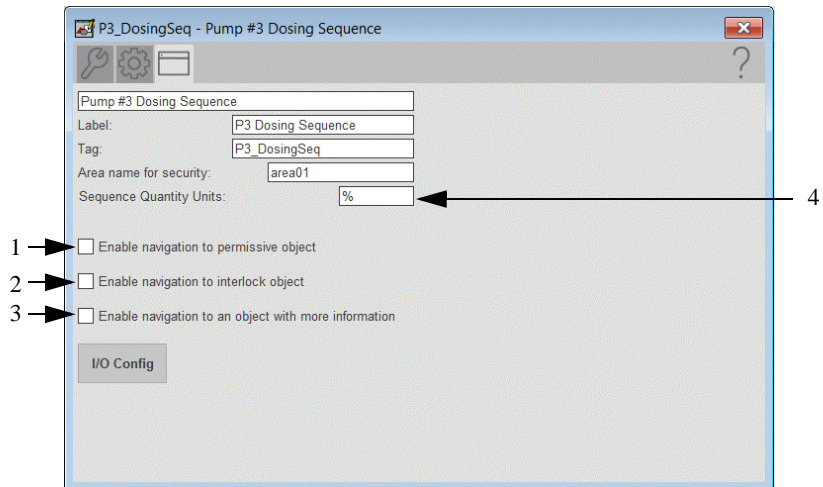
Figure 25 - Multiple Step Configuration Inputs





*HMI Configuration Tab*

The HMI configuration tab provides access to displayed text, and faceplate-to-faceplate navigation settings. Configure the description, label, tag, and security area for the device. See [Basic Faceplate Attributes on page 32](#) for the description of the common attributes.

**Table 154 - HMI Configuration Tab Description**

Item	Description
1	Check if a Permissive object is used with this motor. This check changes the Permissive indicator to a clickable button to open the Permissive faceplate. <b>IMPORTANT:</b> The name of the Permissive object in the controller must be the name of the object with the suffix ‘_Perm’. For example, if your P_Seq object has the name ‘Seq123’, then its Permissive object must be named ‘Seq123_Perm’.
2	Check if an Interlock object is used with this motor. This check changes the Interlock indicator to a clickable button to open the Interlock faceplate. <b>IMPORTANT:</b> The name of the Interlock object in the controller must be the name of the object with the suffix ‘_Intlk’. For example, if your P_Seq object has the name ‘Seq123’, then its Interlock object must be named ‘Seq123_Intlk’.
3	Check to enable navigation to an object with more information (Cfg_HasMoreObj is set to true.) This can be configured to navigate to an AOI backing tag or a UDT tag that has HMI_Type and HMI_Lib defined. For example, there is a motor with the tag name P_101 and there is a need to have the more information button navigate to the parent P_LLS object. A tag is created for the P_LLS object that is given the alias P101_More. When the more information button is pressed on the motor, it links to P101_More. This will open the faceplate for the LLS object.
4	Type the engineering units for the quantity.

## Diagnostics Tab

The Diagnostic tab provides indications that are helpful to diagnose or help prevent device problems. The device problems can include specific reasons a device is 'Not Ready', device warnings and faults, warning and fault history, and predictive/preventive maintenance data.

The Diagnostics tab displays possible reasons for the device not being ready. See [Diagnostics Tab on page 36](#)

## Alarms Tab

The Alarms tab displays each configured alarm. The icon on the tab for the alarms page changes color to show the current active alarm status. A blinking alarm icon indicates that one or more alarms must be acknowledged or the device must be reset. See [Common Alarm Block \(P Alarm\) on page 66](#) for more information.

## Dosing (P\_Dose)

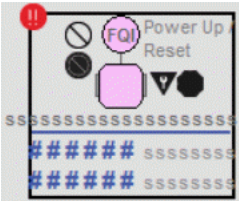
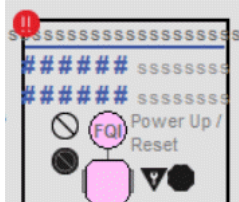
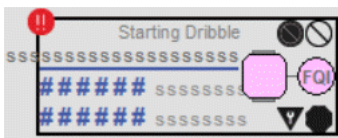

The P\_Dose Add-On Instruction controls ingredient addition to measure the quantity of ingredient that is being added. The instruction can be used for a flowmeter or weigh scale.

This document is for the visualization files, display elements, global objects, and HMI information. The operation of the Add-on Instructions and controller code is contained in publication [PROCES-RM013](#).


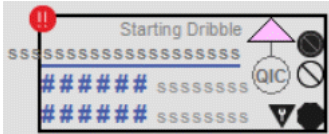

### Display Elements

A display element (global object) is created once and can be referenced multiple times on multiple displays in an application. When changes are made to the original (base) object, the instantiated copies (reference objects) are automatically updated. Use of global objects, with tag structures in the ControlLogix system, aid consistency and save engineering time.

**Table 155 - P\_Dose Display Elements Description**

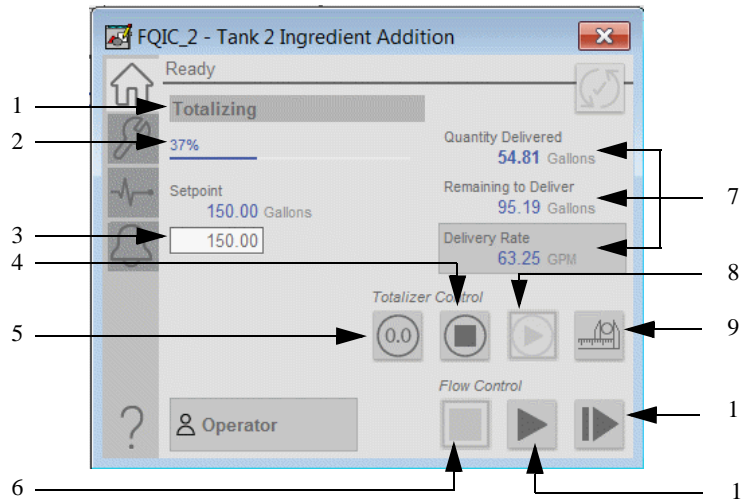
Display Element Name	Display Element	Description
GO_P_DoseFM		Vertical Orientation Top
GO_P_DoseFM1		Vertical Orientation Bottom
GO_P_DoseFM2		Horizontal Orientation Right
GO_P_DoseFM3		Horizontal Orientation Left

**Table 155 - P\_Dose Display Elements Description**

Display Element Name	Display Element	Description
GO_P_DoseWS		Vertical orientation up.
GO_P_DoseWS1		Horizontal orientation right.
GO_P_DoseWS2		Horizontal orientation left.

## Operator Tab

The Faceplate initially opens to the Operator (Home) tab. From here, an operator can monitor the device status and manually operate the device when it is in Operator command source. Several features are common to all Add-On Instructions faceplates. See [Basic Faceplate Attributes on page 32](#).

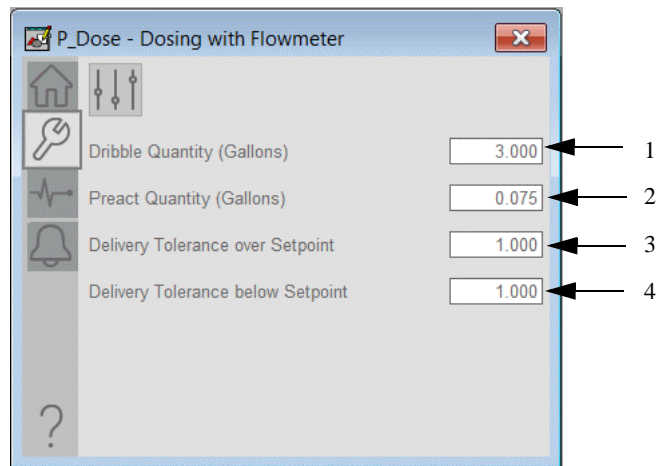


**Table 156 - Operator Tab Description**

Item	Description
1	Dosing Equipment Commanded State.
2	Delivery Progress Bar.
3	Configure the quantity to deliver.
4	Click to stop the Totalizer.
5	Click to clear the totalized quantity.
6	Click to stop the Totalizer flow.
7	Delivery progress.
8	Click to start the Totalizer.
9	Click to check tolerances.
10	Click to bump the Totalizer flow.
11	Click to start the Totalizer flow.

## Maintenance Tab

Maintenance personnel use the information and controls on the Maintenance tab to adjust device parameters, troubleshoot, temporarily work around device problems, and disable the device for routine maintenance. Several features are common to all Add-On Instructions faceplates. See [Basic Faceplate Attributes on page 32](#)



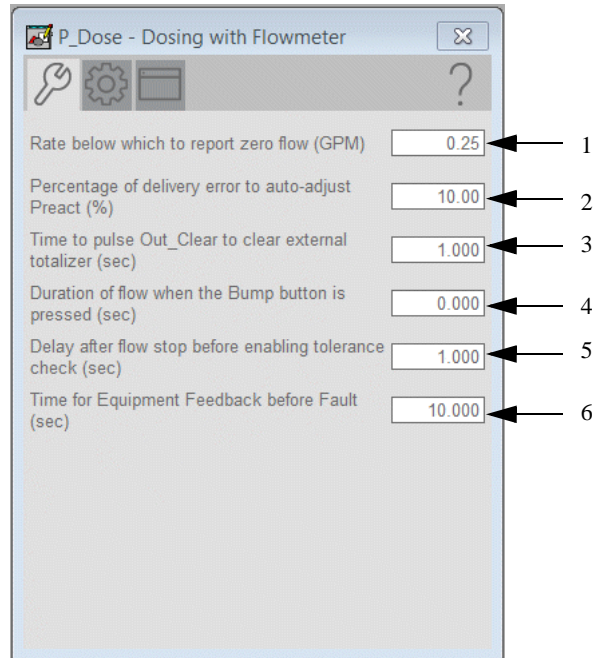
**Table 157 - Maintenance Tab Description**

Item	Description
1	Configure the quantity before the end of delivery, when a switch to a reduced flow rate (dribble) for finer control of the final quantity is made.
2	Configure the quantity before reaching the Setpoint Quantity when a command the delivery equipment to stop to allow equipment to react. The preact quantity helps prevent overshooting the delivery Setpoint.
3	Type the quantity by which delivery can exceed the setpoint. If the delivered quantity is more than the setpoint plus this value, a tolerance check shows over tolerance.
4	Type the quantity by which delivery can fall short of the setpoint. If the delivered quantity is less than the setpoint minus this value, a tolerance check shows under tolerance.

## Advanced Properties Display

The Advanced Properties Display opens to the Advanced Maintenance settings. The Advanced Properties Display provides access to device configuration parameters and ranges, and options for device and I/O setup. This tab is used for initial system commissioning or later system changes.

### Advanced Maintenance Tab



**Table 158 - Advanced Maintenance Tab Description**

Item	Description
1	Type a value so that when the flow rate is less than this value, it is treated as zero. This value helps prevent totalizing the transmitter error when flow is stopped.
2	Type the percentage of delivery error. When the delivery tolerance is checked, if no bump has occurred and if the delivery is in tolerance, the error (difference between delivery setpoint and actual delivery) is multiplied by this percentage and applied to the preact. The preact self tunes and learns the correct value of the preact over time.
3	Configure the Time (in seconds) to Pulse the Clear Output to clear an external totalizer, such as one in an intelligent flowmeter.
4	Type the amount of time to command the controlled equipment to run flow when the bump command button is pressed. If this value is set to zero, Bump is treated like a Jog: flow starts when the button is pressed and stops when the button is released. If this value is greater than zero, flow is bumped for the configured time.
5	Type the amount of time in seconds after flow is stopped for the scale reading to settle before a tolerance check can be commanded.
6	Type the maximum allowed feedback time. If equipment feedback is being used, the instruction allows this much time after commanding the equipment for feedback to show the equipment in the commanded state before raising a fault status.

Engineering Tab

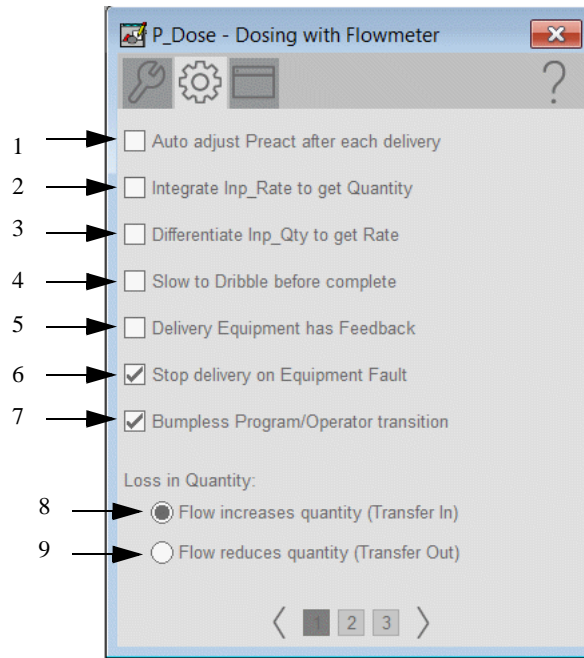
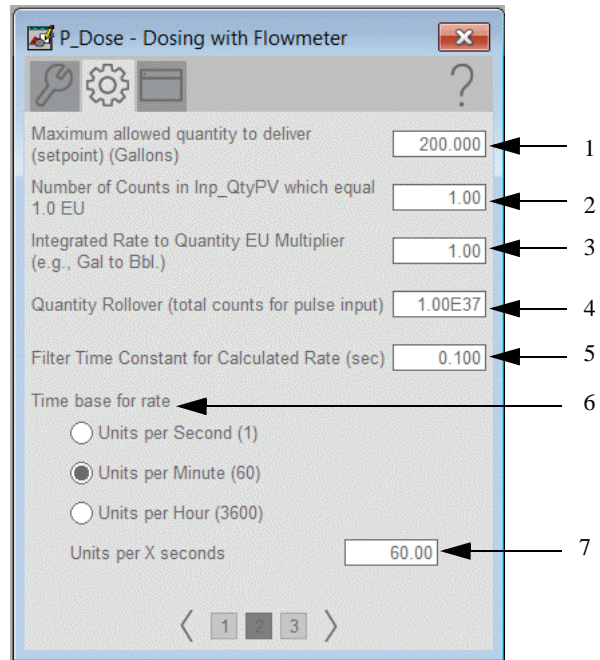


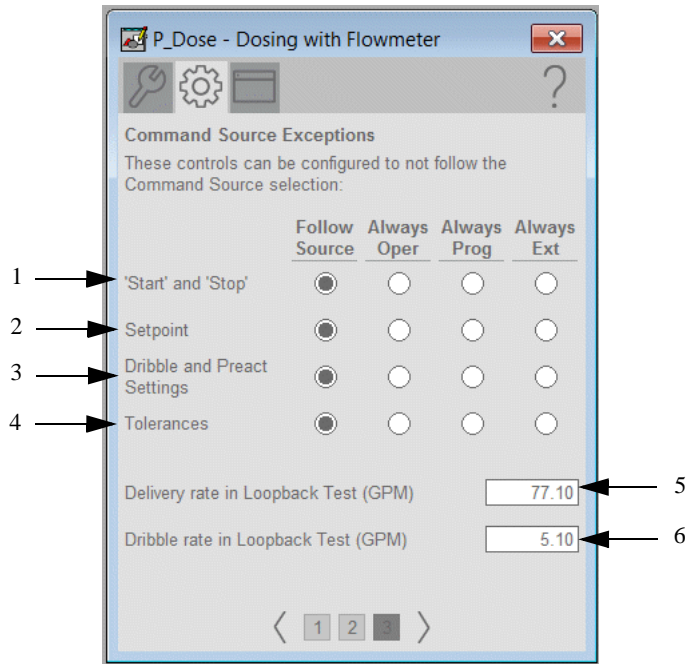
Table 159 - Engineering Page 1 Description

Item	Description
1	Check to adjust the Preact automatically based on the actual versus setpoint Quantity after each successful delivery. Clear this checkbox to leave the Preact as entered.
2	Check if the flowmeter provides a Rate input but no Quantity input. The Rate is totalized (integrated) to calculate Quantity.
3	Check if the flowmeter provides a Quantity input but no Rate input. The rate of change in the Quantity is used as the Rate.
4	Check to command the equipment to a slower Dribble rate as delivery nears completion to improve the accuracy of Quantity delivered.
5	Check if the controlled equipment provides feedback of its running, dribbling, and stopped status to this instruction. This instruction checks that the equipment is performing the commanded function and provides a status (and optional alarm) if the equipment fails to respond as commanded within a configurable time. <b>IMPORTANT:</b> The feedback fault time is configured on the Advanced Maintenance tab. Clear this checkbox if the controlled equipment does not provide feedback of its status. The instruction assumes that the equipment is performing the commanded function and no equipment failure-to-respond checks occur.
6	Check if you want the dosing instruction to attempt to stop the controlled equipment if an equipment fault is reported (Inp_CtrldEquipFault) or detected (via feedbacks). Clear this checkbox if you want the dosing instruction to keep performing its current function, even if an equipment fault occurs.
7	Check to enable bumpless Program/Operator transition of Quantity Setpoint, Dribble Quantity, Preact, and Tolerance Threshold settings (tracking).
8	Check to designate as a Transfer In instance.
9	Check to designate as a Transfer Out instance.



**Table 160 - Engineering Tab Page 2 Description**

Item	Description
1	Type the maximum allowed quantity to deliver. The quantity setpoint is clamped not to exceed this value.
2	Type the number of counts in Inp_QtyPV that equal one engineering unit of quantity delivered. This value is used with pulse output flowmeters and a pulse input I/O card.
3	Type the rate to quantity engineering units multiplier. This value is used if the input is in one unit of measure, such as gallons per minute, and the total is in another that requires conversion above and beyond time units, such as barrels.
4	Type the quantity rollover. This value is used when a quantity or pulse count input rolls over to zero at some value, such as 999,999 counts.
5	Type the filter time constant for calculated rate.
6	Click to set the time base for rate.
7	Type the number of units per x seconds, where x equals the number of seconds selected for the time base for rate.

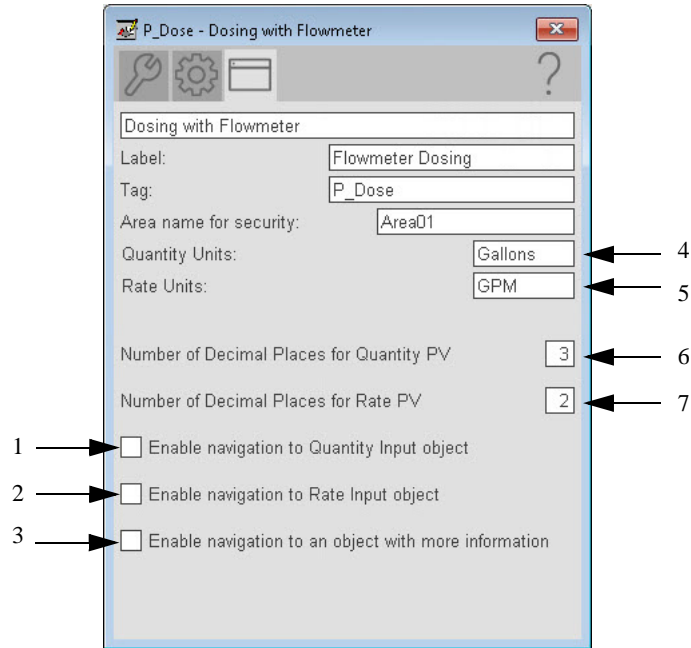


**Table 161 - Engineering Tab Page 3 Description**

Item	Description
1	Check to keep control of dosing Start and Stop commands with the Operator, Program, External, or Follow the Source even if the instruction is in Program command source.
2	Check to keep control of the Setpoint quantity setting with the Operator, Program, External, or Follow the Source even if the instruction is in Program command source.
3	Check to keep control of the Dribble and Preact quantity settings with the Operator, Program, External, or Follow the Source even if the instruction is in Program command source.
4	Check to keep control of the high and low Tolerance settings with the Operator, Program, External, or Follow the Source even if the instruction is in Program command source.
5	Type the normal running delivery rate that is used when the P_Dose instruction is in simulation (Inp_Sim = 1).
6	Type the dribble (slow) delivery rate that is used when the P_Dose instruction is in simulation (Inp_Sim = 1).

## HMI Configuration Tab

The HMI configuration tab provides access to displayed text, and faceplate-to-faceplate navigation settings. Configure the description, label, tag, and security area for the device. See [Basic Faceplate Attributes on page 32](#) for the description of the common attributes.



**Table 162 - HMI Configuration Tab Description**

Item	Description
1	Check to enable navigation to the Quantity Input object faceplate. <b>IMPORTANT:</b> The name of the Channel Quantity object in the controller must be the name of the object with the suffix ‘_ChanQty’. For example, if your P_Dose object has the name ‘DoseFM123’, then its Channel Quantity object must be named ‘DoseFM123_ChanQty’.
2	Check to enable navigation to the Rate Input object faceplate. <b>IMPORTANT:</b> The name of the Channel Rate object in the controller must be the name of the object with the suffix ‘_ChanRate’. For example, if your P_Dose object has the name ‘DoseFM123’, then its Channel Rate object must be named ‘DoseFM123_ChanRate’.
3	Check to enable navigation to an object with more information (Cfg_HasMoreObj is set to true.) This can be configured to navigate to an AOI backing tag or a UDT tag that has HMI_Type and HMI_Lib defined. For example, there is a motor with the tag name P_101 and there is a need to have the more information button navigate to the parent P_LLS object. A tag is created for the P_LLS object that is given the alias P101_More. When the more information button is pressed on the motor, it links to P101_More. This will open the faceplate for the LLS object.
4	Type the units of measure descriptor for the Quantity delivered.

<b>Item</b>	<b>Description</b>
5	Type the units of measure descriptor for the Rate of delivery.
6	Type in the number of decimal places that are displayed for the Quantity Process Variable
7	Type in the number of decimal places that are displayed for the Rate Process Variable

## **Diagnostics Tab**

The Diagnostic tab provides indications that are helpful to diagnose or help prevent device problems. The device problems can include specific reasons a device is 'Not Ready', device warnings and faults, warning and fault history, and predictive/preventive maintenance data.

The Diagnostics tab displays possible reasons for the device not being ready. See [Diagnostics Tab on page 36](#)

## **Alarms Tab**

The Alarms tab displays each configured alarm. The icon on the tab for the alarms page changes color to show the current active alarm status. A blinking alarm icon indicates that one or more alarms must be acknowledged or the device must be reset. See [Common Alarm Block \(P\\_Alarm\) on page 66](#) for more information.

## Lead/Lag/Standby Motor Group (P\_LLS)

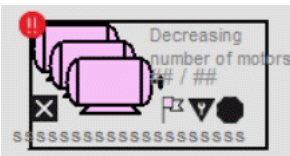
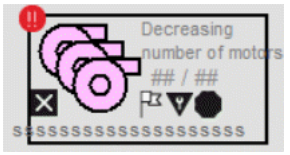
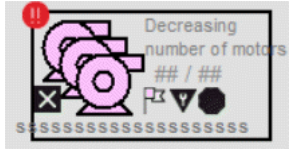
The P\_LLS (Lead/Lag/Standby motor group) Add-On Instruction provides control of a parallel group of motors. Such groups are commonly used for a group of pumps that maintain pressure on a header despite wide changes in demand, such as in municipal-scale or plant-scale water distribution.

This document is for the visualization files, display elements, global objects, and HMI information. The operation of the Add-on Instructions and controller code is contained in publication [PROCES-RM013](#).

### Display Elements

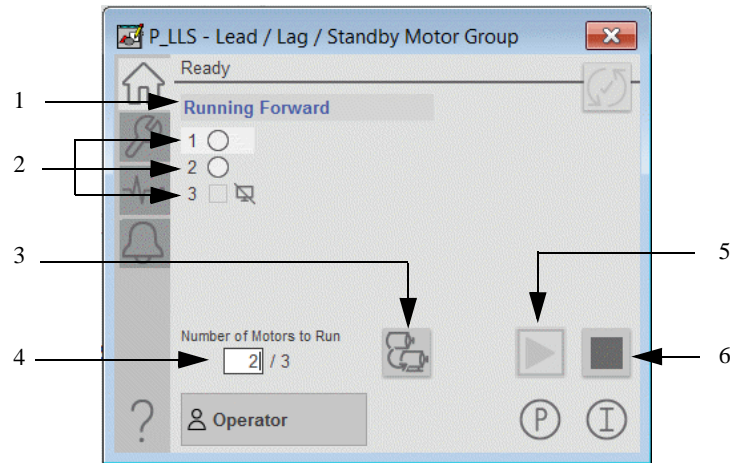
A display element (global object) is created once and can be referenced multiple times on multiple displays in an application. When changes are made to the original (base) object, the instantiated copies (reference objects) are automatically updated. Use of global objects, with tag structures in the ControlLogix system, aid consistency and save engineering time.

**Table 163 - P\_LLS Display Elements**

Display Element Name	Display Element	Description
GO_P_LLS_Motors		A group of motors.
GO_P_LLS_Blowers		A group of blowers.
GO_P_LLS_Pumps		A group of pumps.

## Operator Tab

The Faceplate initially opens to the Operator (Home) tab. From here, an operator can monitor the device status and manually operate the device when it is in Operator command source. Several features are common to all Add-On Instructions faceplates. See [Basic Faceplate Attributes on page 32](#).

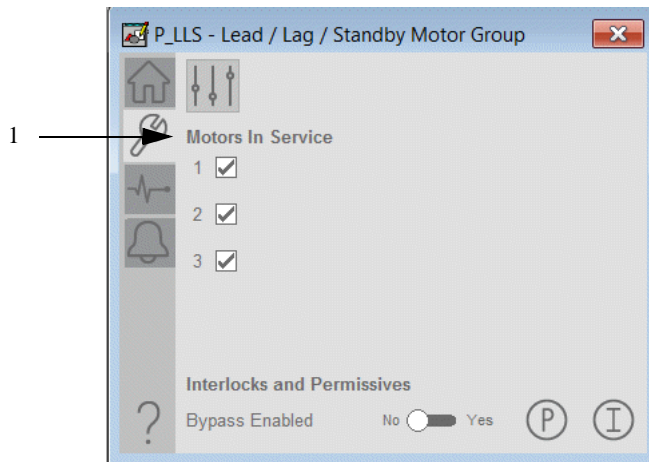


**Table 164 - Operator Tab Description**

Item	Description
1	Motor state indicator.
2	Individual motor state indicators.
3	Click to rotate motor assignments. The lead motor is demoted to the end of the list. Motors are started or stopped to satisfy Number of Motors to Run.
4	Type a number between 0 and the maximum demand to indicate the number of motors to run.
5	Click to start group.
6	Click to stop group. <b>IMPORTANT:</b> Motors stop in reverse order of starting unless First Started is First Stopped on the engineering tab is checked.

## Maintenance Tab

Maintenance personnel use the information and controls on the Maintenance tab to adjust device parameters, troubleshoot, temporarily work around device problems, and disable the device for routine maintenance. Several features are common to all Add-On Instructions faceplates. See [Basic Faceplate Attributes on page 32](#)



**Table 165 - Maintenance Tab Description**

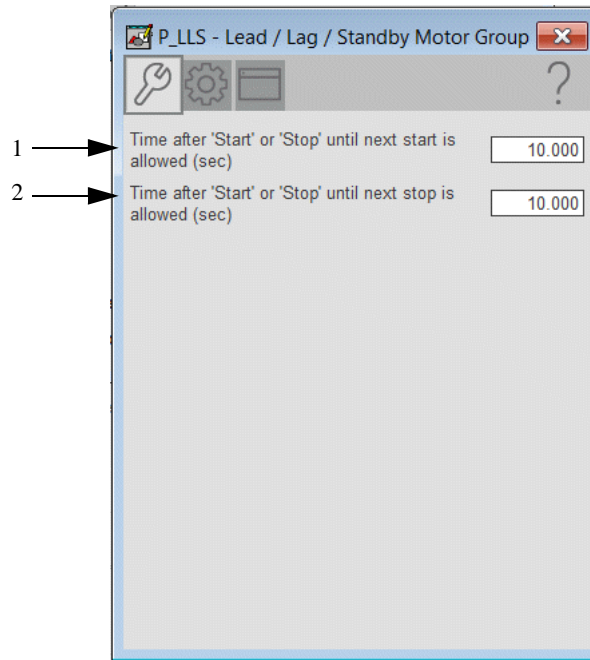
Item	Description
1	Check to place a motor in service (not in maintenance bypass). Clear the checkbox to place a motor out of service (maintenance bypass)



## Advanced Properties Display

The Advanced Properties Display opens to the engineering settings. The Advanced Properties Display provides access to device configuration parameters and ranges, and options for device and I/O setup. This tab is used for initial system commissioning or later system changes.

### *Maintenance Tab*



**Table 166 - Advanced Maintenance Tab Description**

Item	Description
1	Type the number of seconds after a start or stop that the next start is allowed.
2	Type the number of seconds after a start or stop that the next stop is allowed.

Engineering Tab

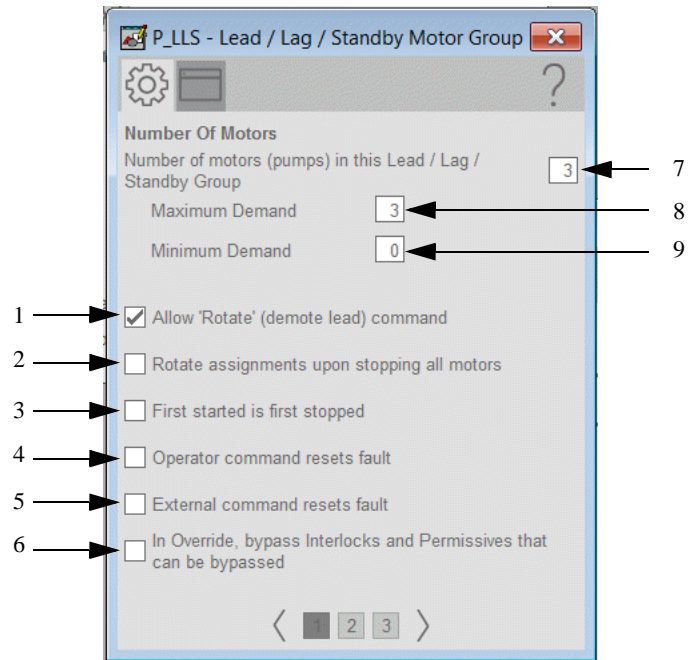


Table 167 - Engineering Tab Page 1 Description

Item	Description
1	Check to allow the Rotate command to rotate motor assignments.
2	Check to rotate the lead motor to the end of list upon stopping all motors.
3	Check so that the first motor that is started is the first motor that is stopped.
4	Check to allow the Operator Start or Stop command to reset any previous faults (Interlock Trip), then start or stop the group. Clear this checkbox to reset faults by using only the reset commands.
5	Check to allow the External Start or Stop command to reset any previous faults (Interlock Trip), then start or stop the group. Clear this checkbox to reset faults by using only the reset commands.
6	Check to bypass interlocks and permissives that are bypassable when in Override command source.
7	Type the number of motors (2...30) in the group.
8	Type the highest number of motors that can be running.
9	Type the lowest number of motors that can be running.

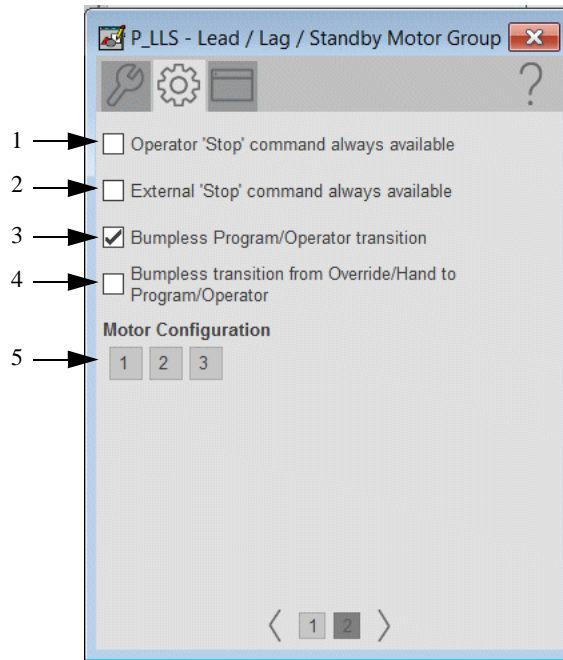
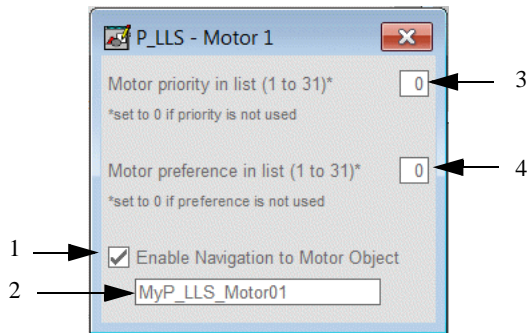


Table 168 - Engineering Tab Page 2 Description

Item	Description
1	Check (= 1) so that the OCmd_Stop has priority and is accepted at any time. If the Command Source is not Operator or Maintenance, the motor or drive requires a reset. Clear this checkbox (= 0) so that the OCmd_Stop works only in Operator or Maintenance command source.
2	Check (= 1) so that the XCmd_Stop has priority and is accepted at any time. If the Command Source is not External, the motor or drive requires a reset. Clear this checkbox (= 0) so that the XCmd_Stop only works when the command source is External.
3	Check to have Program settings (such as Speed Reference) track Operator settings in Operator command source, and have Operator settings track Program settings in Program command source.
4	Check to have Program and Operator Speed Reference track the Override Speed Reference in Override command source or the actual speed in Hand command source.
5	Click a number to open the corresponding Motor Configuration dialog box.

*Motor Configuration Dialog Box*

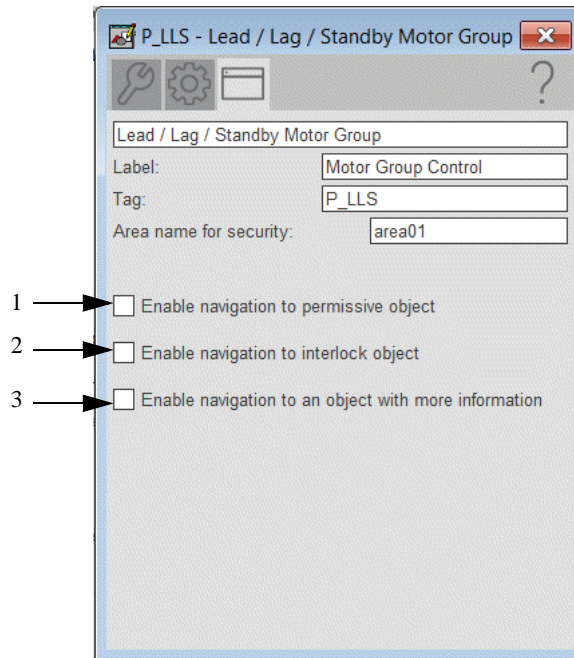


**Table 169 - Motor Configuration Dialog Box Description**

Item	Description
1	Check to enable navigation to a motor object.
2	Type the name of the motor object to navigate to. <b>IMPORTANT:</b> This field is only visible when Enable Navigation to Motor Object is checked.
3	Type the start priority within the list of the motors selected. Motors start in order of priority (0...31) and the higher numbers start first.
4	Type the starting preference of the motor selected. When two or more motors have the same priority, these motors start in the order of preference (0...31) and the higher numbers start first.

## HMI Configuration Tab

The HMI configuration tab provides access to displayed text, and faceplate-to-faceplate navigation settings. Configure the description, label, tag, and security area for the device. See [Basic Faceplate Attributes on page 32](#) for the description of the common attributes.



**Table 170 - HMI Configuration Tab Description**

Item	Description
1	Check if a Permissive object is used with this motor. This check changes the Permissive indicator to a clickable button to open the Permissive faceplate. <b>IMPORTANT:</b> The name of the Permissive object in the controller must be the name of the object with the suffix '_Perm'. For example, if your P_LLS object has the name 'LLS123', then its Permissive object must be named 'LLS123_Perm'.
2	Check if an Interlock object is used with this group. Checking this box changes the Interlock indicator to a clickable button to open the Interlock faceplate. <b>IMPORTANT:</b> The name of the Interlock object in the controller must be the object name with the suffix '_Intlk'. For example, if your P_LLS object has the name 'LLS123', then its Interlock object must be named 'LLS123_Intlk'.
3	Check to enable navigation to an object with more information (Cfg_HasMoreObj is set to true.) This can be configured to navigate to an AOI backing tag or a UDT tag that has HMI_Type and HMI_Lib defined. For example, there is a motor with the tag name P_101 and there is a need to have the more information button navigate to the parent P_LLS object. A tag is created for the P_LLS object that is given the alias P101_More. When the more information button is pressed on the motor, it links to P101_More. This will open the faceplate for the LLS object.

## Diagnostics Tab

The Diagnostic tab provides indications that are helpful to diagnose or help prevent device problems. The device problems can include specific reasons a device is 'Not Ready', device warnings and faults, warning and fault history, and predictive/preventive maintenance data.

The Diagnostics tab displays possible reasons for the device not being ready. See [Diagnostics Tab on page 36](#)

## Alarms Tab

The Alarms tab displays each configured alarm. The icon on the tab for the alarms page changes color to show the current active alarm status. A blinking alarm icon indicates that one or more alarms must be acknowledged or the device must be reset. See [Common Alarm Block \(P\\_Alarm\) on page 66](#) for more information.

**Notes:**





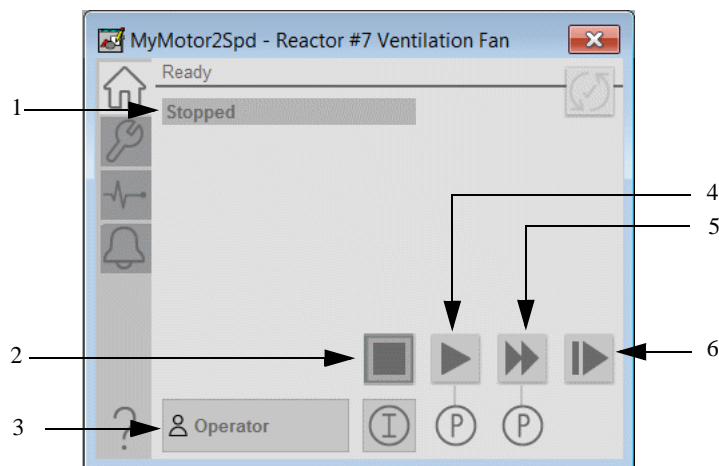
## Motors Family

The Process Objects in this group provide control and monitoring for smart motor controllers, drives, and overload relays. This document is for the visualization files, display elements, global objects, and HMI information. The operation of the Add-on Instructions and controller code is contained in publication [PROCES-RM013](#).

### Common Motors Faceplates

Faceplate attributes are common to several Add-On Instructions in the motors family. Attributes specific to a motor are detailed in the individual sections. If a functionality is not enabled, the buttons are not visible. Common attributes for motors are detailed in this section. Basic attributes are described in the overview. See [Basic Faceplate Attributes on page 32](#)

#### Common Operator Tab - Motors

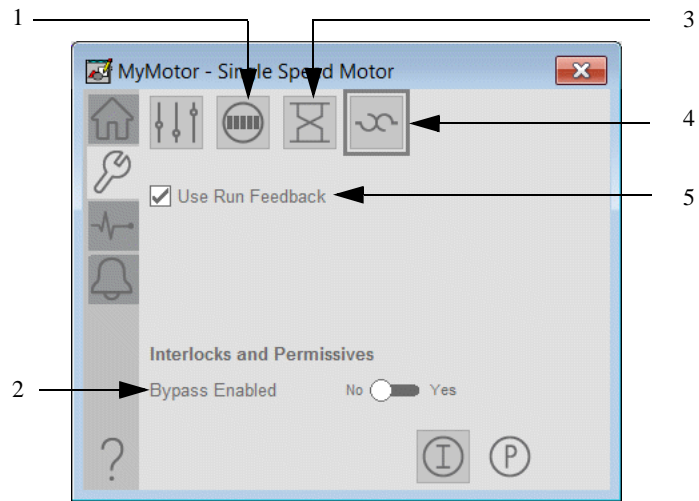


**Table 171 - Common Operator Tab Attributes**

Item	Description
1	Motor state (stopping, stopped, starting, or running)
2	Motor stop
3	Current command source (Program, Operator, Override, Maintenance, or Hand)

Item	Description
4	Click to start motor slow (motor run for single speed motors)
5	Click to start motor fast
6	Click to jog Motor

*Common Maintenance Tab - Motors*

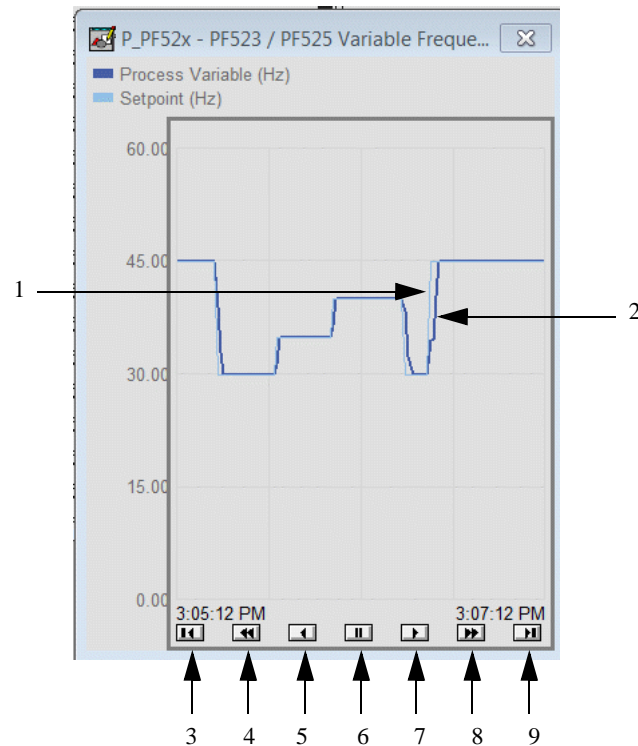


**Table 172 - Common Maintenance Tab Attributes**

Item	Description
1	Click to open the runtime faceplate. <b>IMPORTANT:</b> This option is only available if 'Enable navigation to run time object' on the HMI Configuration tab is checked. See <a href="#">Run Time and Start Counter (P RunTime) on page 406</a>
2	Click Yes to bypass checking of bypassable interlocks and permissives. Click No to enable checking of all interlocks and permissives.
3	Click to open the Restart Inhibit faceplate. <b>IMPORTANT:</b> This option is only available if 'Enable navigation to restart inhibit object' on the HMI Configuration tab is checked. See <a href="#">Restart Inhibit for Large Motor (P ResInh) on page 408</a>
4	Click to open the Overload faceplate. <b>IMPORTANT:</b> This option is only available if 'Enable navigation to overload object' on the HMI Configuration tab is checked.
5	Check to have this instruction use run feedback to check for motor Fail to Start or fail to Stop. <b>IMPORTANT:</b> This option is only available if 'Motor has Run Feedback' on page 1 of the Engineering tab is checked.

### Common Trends Tab - Motors

The Trends tab shows trend charts of key device data over time. These faceplate trends provide a quick view of current device performance to supplement, but not replace, dedicated historical or live trend displays. The trends displays are common across all Motors Family Add-On Instructions



**Table 173 - Common Trends Tab Description**

Item	Description
1	Setpoint
2	Process Variable
3	Click to view the oldest data available.
4	Click to move trend data back 2 minutes.
5	Click to move trend data back 1 minute.
6	Click to scroll new data.
7	Click to move trend data forward 1 minute.
8	Click to move trend data forward 2 minutes.
9	Click to move to the most current trend data.

# Single-speed Motor (P\_Motor)

The P\_Motor (Single-speed Motor) Add-On Instruction controls a non-reversing, single-speed motor in various command sources and monitors for fault conditions.

This document is for the visualization files, display elements, global objects, and HMI information. The operation of the Add-on Instructions and controller code is contained in publication [PROCES-RM013](#).



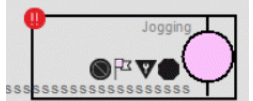
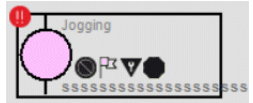

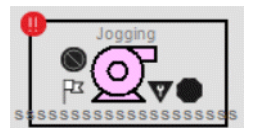




## Display Elements (P\_Motor)

A display element (global object) is created once and can be referenced multiple times on multiple displays in an application. When changes are made to the original (base) object, the instantiated copies (reference objects) are automatically updated. Use of global objects, with tag structures in the ControlLogix® system, aid consistency and save engineering time.

**Table 174 - P\_Motor Display Elements**

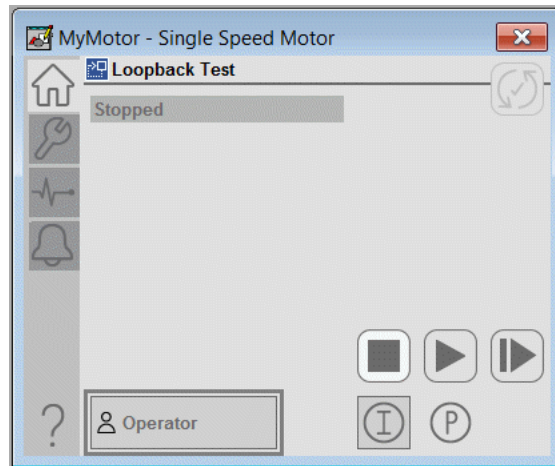
Display Element Name	Display Element	Description
GO_P_Motor_R GO_P_Motor_U GO_P_Motor_D	<p>The image shows three motor display element icons. The top icon is labeled 'Jogging' and shows a motor with a right-pointing arrow. The middle icon is labeled 'Stopping' and shows a motor with a right-pointing arrow. The bottom icon is labeled 'Stopping' and shows a motor with a right-pointing arrow. Each icon includes a red '!!' symbol in the top left corner, a 'Pz' symbol, and a 'V' symbol.</p>	Motors operate in different positions: right, up, and down.
GO_P_Motor_Blower_R GO_P_Motor_Blower_L GO_P_Motor_Blower_U GO_P_Motor_Blower_D	<p>The image shows four blower display element icons. The top icon is labeled 'Jogging' and shows a blower with a right-pointing arrow. The second icon is labeled 'Jogging' and shows a blower with a left-pointing arrow. The third icon is labeled 'Stopping' and shows a blower with a right-pointing arrow. The bottom icon is labeled 'Stopping' and shows a blower with a left-pointing arrow. Each icon includes a red '!!' symbol in the top left corner, a 'Pz' symbol, and a 'V' symbol.</p>	Blowers operate in different positions: right, left, up, and down.

**Table 174 - P\_Motor Display Elements**

Display Element Name	Display Element	Description
GO_P_Motor_Conveyer_R		Conveyor that is shown as a display element.
GO_P_Motor_Inline_U		Inline motors operate in several positions: up, right, left, and down.
GO_P_Motor_Inline_R		
GO_P_Motor_Inline_L		
GO_P_Motor_Inline_D		
GO_P_Motor_Pump_R		Pumps operate in several positions: right, left, and up.
GO_P_Motor_Pump_L		
GO_P_Motor_Pump_U		
GO_P_Motor_Agitator_D		Agitator that is shown as a display element.
GO_P_Motor_Mixer_U		Mixer that is shown as a display element.
GO_P_Motor_RPump_U		Rotary gear pump that is shown as a display element.
GO_P_Motor_Fan_D		Fan that is shown as a display element.

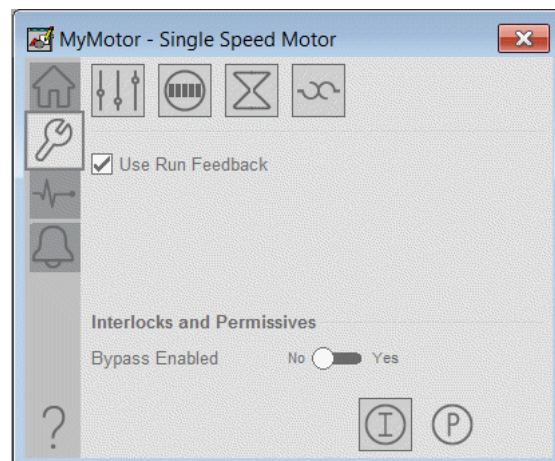
## Operator Tab

The Faceplate initially opens to the Operator (Home) tab. From here, an operator can monitor the device status and manually operate the device when it is in Operator command source. Several features are common to all Add-On Instructions faceplates for the motors family. See [Common Operator Tab - Motors on page 247](#)



## Maintenance Tab

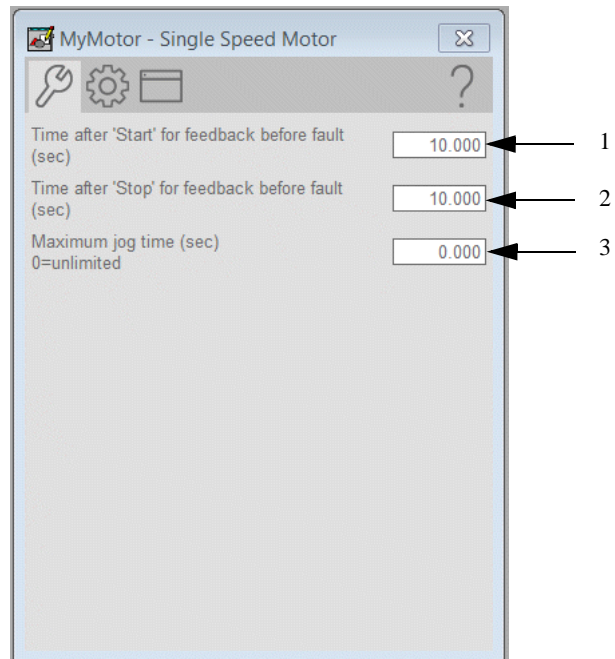
Maintenance personnel use the information and controls on the Maintenance tab to adjust device parameters, troubleshoot, temporarily work around device problems, and disable the device for routine maintenance. Several features are common to all Add-On Instructions faceplates for the motors family. See [Common Maintenance Tab - Motors on page 248](#)



## Advanced Properties Display

The Advanced Properties Display opens to the advanced maintenance settings. The Advanced Properties Display provides access to device configuration parameters and ranges, and options for device and I/O setup. This tab is used for initial system commissioning or later system changes.

### *Advanced Maintenance Tab*



**Table 175 - Advanced Maintenance Tab Description**

Item	Description
1	Type the time, in seconds, to allow the run feedback to show that the motor has started before raising a fail to start alarm.
2	Type the time, in seconds, to allow the run feedback to show that the motor has stopped before raising a fail to stop alarm.
3	Type the time, in seconds, for the maximum jog time for the motor.

Engineering Tab

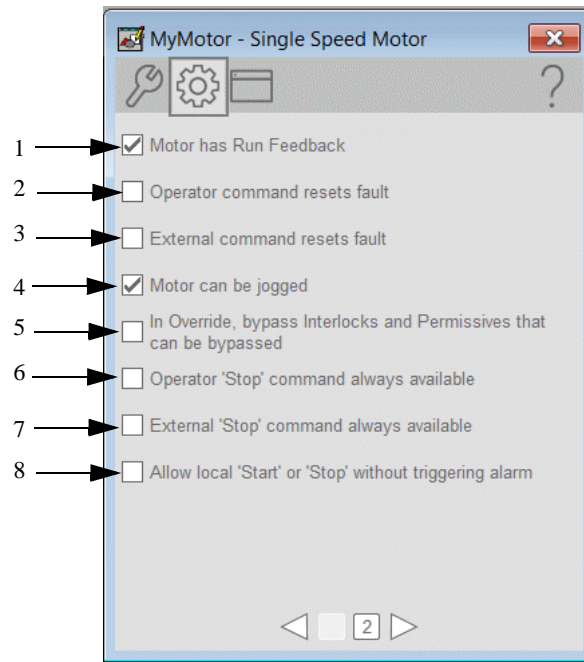
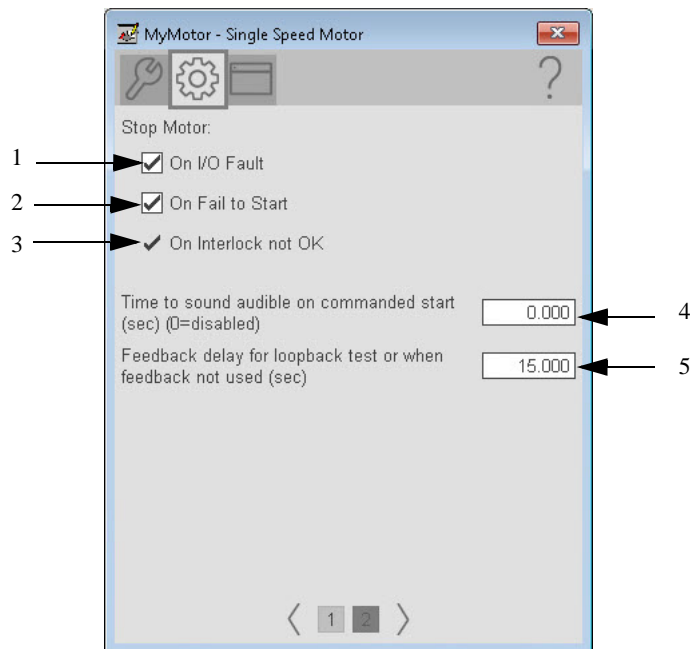


Table 176 - Engineering Tab Page 1 Description

Item	Description
1	Check if the motor provides a run feedback to Inp_RunFdbk. Clear this checkbox if there is no run feedback. <b>IMPORTANT:</b> This check places the device in Maintenance Bypass unless 'Use Run Feedback' on the Maintenance tab is checked.
2	Check to allow the Operator Start or Stop command to reset any previous faults (I/O fault, Fail to Start, Fail to Stop, or Interlock Trip), then start or stop motor. Clear this checkbox to reset faults by using only the reset commands.
3	Check to allow the External Start or Stop command to reset any previous faults (I/O fault, Fail to Start, Fail to Stop, or Interlock Trip), then start or stop motor. Clear this checkbox to reset faults by using only the reset commands.
4	Check to enable the jog feature of the motor.
5	Check to allow the Operator Start or Stop command to reset any previous faults (I/O fault, Fail to Start, Fail to Stop, or Interlock Trip), then start or stop motor. Clear this checkbox to reset faults by using only the reset commands.
6	Check to have the Operator Stop command available in any command source. Clear this checkbox to have the Operator Stop command available only in the Operator and Maintenance command sources.
7	Check to have the External Stop command available in any command source. Clear this checkbox to have the External Stop command available only in the Operator and Maintenance command sources.
8	Check to allow local Start/Stop without alarm. Clear this checkbox to allow start/stop by using only Program or Operator commands or Override Logic.



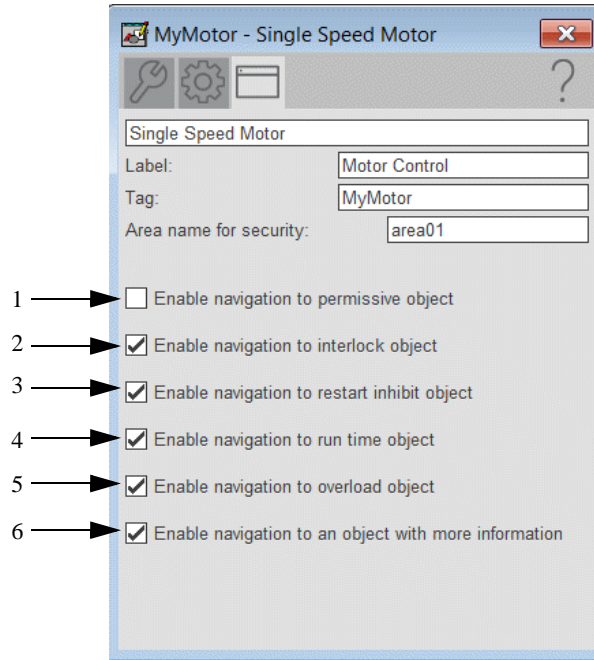


**Table 177 - Engineering Tab Page 2 Description**

Item	Description
1	Check to stop the motor if an I/O fault is detected. Clear this checkbox to show only the I/O fault status/alarm and not stop the motor if an I/O fault is detected.
2	Check to stop the motor if a fail to Start fault is detected. Clear this checkbox to show only the Fail to Start status/alarm and not stop the motor if a fail to Start fault is detected.
3	The motor always stops on an interlock not ok. This item cannot be unchecked. It is displayed as a reminder that the Interlock not OK function always trips the motor.
4	Type the time (in seconds) the audible alarm sounds on a commanded start.
5	Set the time delay (in seconds) for running or stopped status to be echoed back when the simulation is enabled or when run feedback is not used.

### HMI Configuration Tab

The HMI configuration tab provides access to displayed text, and faceplate-to-faceplate navigation settings. Configure the description, label, tag, and security area for the device. See [Basic Faceplate Attributes on page 32](#) for the description of the common attributes.



**Table 178 - HMI Configuration Description**

Item	Description
1	Check if a Permissive object is used with this motor. This check changes the Permissive indicator to a clickable button to open the Permissive faceplate. <b>IMPORTANT:</b> The name of the Permissive object in the controller must be the name of the object with the suffix ‘_Perm’. For example, if your P_Motor object has the name ‘Motor123’, then its Permissive object must be named ‘Motor123_Perm’.
2	Check if an Interlock object is used with this motor. This check changes the Interlock indicator to a clickable button to open the Interlock faceplate. <b>IMPORTANT:</b> The name of the Interlock object in the controller must be the name of the object with the suffix ‘_Intlk’. For example, if your P_Motor object has the name ‘Motor123’, then its Interlock object must be named ‘Motor123_Intlk’.
3	Check if a Restart Inhibit object is used with this motor. This check makes the Restart Inhibit button visible. <b>IMPORTANT:</b> The name of the Restart Inhibit object in the controller must be the name of the object with the suffix ‘_ResInh’. For example, if your P_Motor object has the name ‘Motor123’, then its Restart Inhibit object must be named ‘Motor123_ResInh’.
4	Check if a Run Time object is used with this motor. This check makes the Run Time button visible. <b>IMPORTANT:</b> The name of the Run Time object in the controller must be the name of the object with the suffix ‘_RunTime’. For example, if your P_Motor object has the name ‘Motor123’, then its Run Time object must be named ‘Motor123_RunTime’.

Item	Description
5	<p>Check if an Overload object is used with this motor. This check makes the Overload button visible.</p> <p><b>IMPORTANT:</b> The name of the Overload object in the controller must be the name of the object with the suffix '_Ovld'. For example, if your P_Motor object has the name 'Motor123', then its Overload object must be named 'Motor123_Ovld'</p>
6	<p>Check to enable navigation to an object with more information (Cfg_HasMoreObj is set to true.)</p> <p>This can be configured to navigate to an AOI backing tag or a UDT tag that has HMI_Type and HMI_Lib defined.</p> <p>For example, there is a motor with the tag name P_101 and there is a need to have the more information button navigate to the parent P_LLS object. A tag is created for the P_LLS object that is given the alias P101_More. When the more information button is pressed on the motor, it links to P101_More. This will open the faceplate for the LLS object.</p>

## Diagnostics Tab

The Diagnostic tab provides indications that are helpful to diagnose or help prevent device problems. The device problems can include specific reasons a device is 'Not Ready', device warnings and faults, warning and fault history, and predictive/preventive maintenance data.

The Diagnostics tab displays possible reasons for the device not being ready. See [Diagnostics Tab on page 36](#)

## Alarms Tab

The Alarms tab displays each configured alarm. The icon on the tab for the alarms page changes color to show the current active alarm status. A blinking alarm icon indicates that one or more alarms must be acknowledged or the device must be reset. See [Common Alarm Block \(P\\_Alarm\) on page 66](#) for more information.

## Two-speed Motor (P\_Motor2Spd)

The P\_Motor2Spd (Two-speed Motor) Add-On Instruction controls a non-reversing, two-speed motor (fast/slow/stopped) in various command sources and monitors for fault conditions.

This document is for the visualization files, display elements, global objects, and HMI information. The operation of the Add-on Instructions and controller code is contained in publication [PROCES-RM013](#).

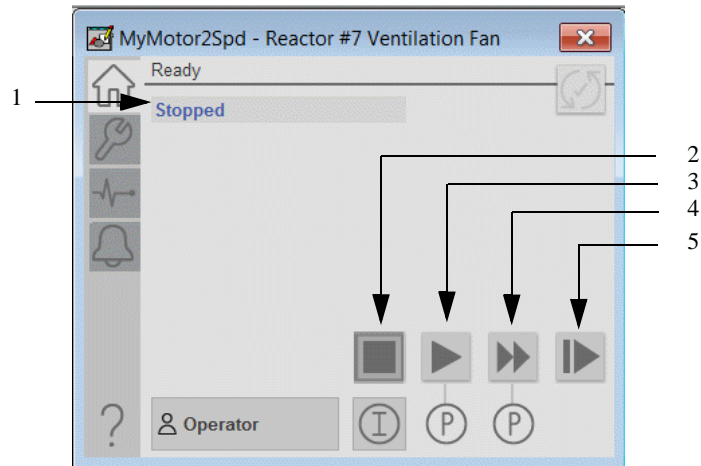
### Display Elements (P\_Motor2Spd)

A display element (global object) is created once and can be referenced multiple times on multiple displays in an application. When changes are made to the original (base) object, the instantiated copies (reference objects) are automatically updated. Use of global objects, with tag structures in the ControlLogix system, aid consistency and save engineering time.

P\_Motor2Spd uses the same Display Elements as P\_Motor. See [Display Elements \(P\\_Motor\) on page 250](#)

## Operator Tab

The Faceplate initially opens to the Operator (Home) tab. From here, an operator can monitor the device status and manually operate the device when it is in Operator command source.

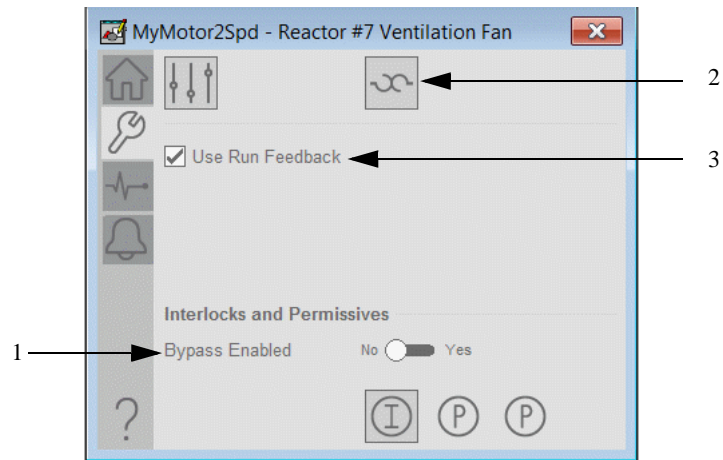


**Table 179 - Operator Tab Description**

Item	Description
1	Motor state indicator.
2	Click to stop motor.
3	Click to start motor slow.
4	Click to start motor fast.
5	Click to jog motor.

## Maintenance Tab

Maintenance personnel use the information and controls on the Maintenance tab to adjust device parameters, troubleshoot and temporarily work around device problems, and disable the device for routine maintenance.

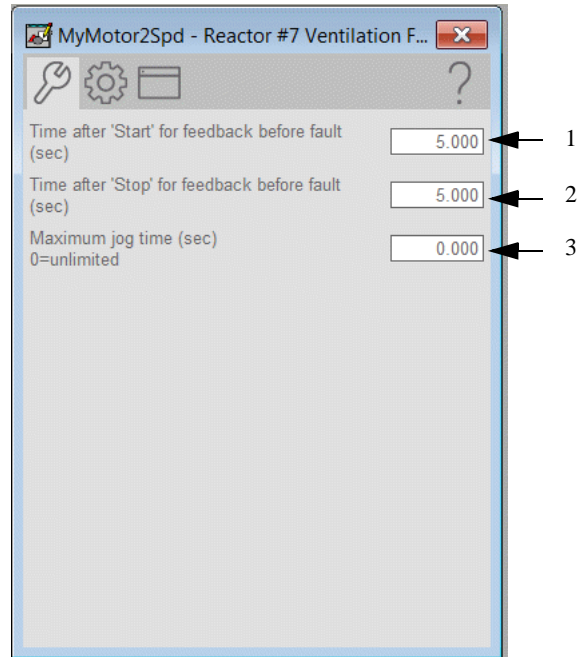


**Table 180 - Maintenance Tab Description**

Item	Description
1	Click Yes to bypass checking of bypassable interlocks and permissives. Click No to enable checking of all interlocks and permissives.
2	Click to open the Overload faceplate. <b>IMPORTANT:</b> This option is only available if 'Enable navigation to overload object' on the HMI Configuration tab is checked.
3	Check to have this instruction use run feedback to check for motor Fail to Start or fail to Stop. <b>IMPORTANT:</b> This option is only available if 'Motor has Run Feedback' on page 1 of the Engineering tab is checked.

## Advanced Properties Display

### Advanced Maintenance Tab



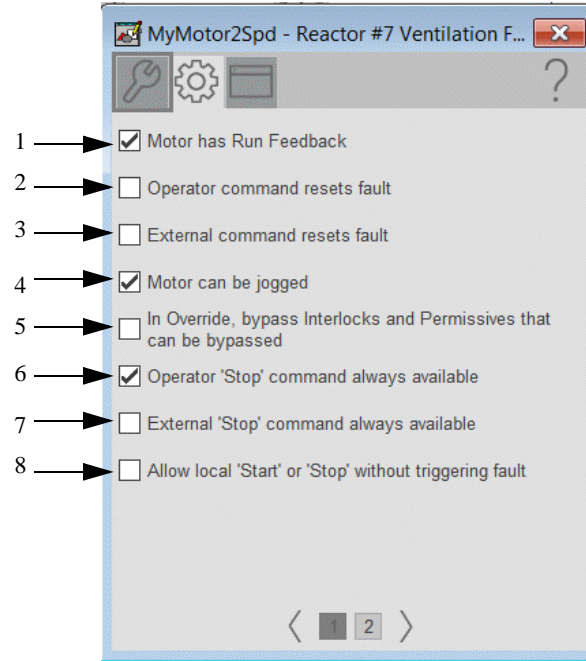
**Table 181 - Advanced Maintenance Tab Description**

Item	Description
1	Type the time to allow the run feedback to show that the motor has started before raising a fail to start alarm.
2	Type the time to allow the run feedback to show that the motor has stopped before raising a Fail to Stop alarm.
3	Type the time to allow the motor to jog.

### Engineering Tab

The Engineering tab is divided into two pages.

#### Engineering Tab Page 1



**Table 182 - Engineering Page 1 Description**

Item	Description
1	Check if the motor provides run feedback to Inp_SlowRunFdbk and Inp_FastRunFdbk. Clear this checkbox if there is no run feedback. <b>IMPORTANT:</b> This check places the device in Maintenance Bypass unless 'Use Run Feedback' on the Maintenance tab is checked.
2	Check to allow the Operator commands for Start Slow, Start Fast, or Stop to reset any previous faults (I/O fault, Fail to Start, Fail to Stop, Interlock Trip). Then start or stop motor. Clear this checkbox to reset faults only using the reset code.
3	Check to allow the External commands for Start Slow, Start Fast, or Stop to reset any previous faults (I/O fault, Fail to Start, Fail to Stop, Interlock Trip). Then start or stop motor. Clear this checkbox to reset faults only using the reset code.
4	Check to allow motor to be jogged.
5	Check to bypass bypassable interlocks and permissives in Override command source.
6	Check to have the Operator Stop command available in any command source. Clear this checkbox to have the Operator Stop command available only in the Operator and Maintenance command sources.
7	Check to have the External Stop command available in any command source. Clear this checkbox to have the External Stop command available only in the Operator and Maintenance command sources.
8	Check to allow local Start/Stop without alarm. Clear this checkbox to allow start/stop only using Program or Operator commands or Override Logic.



## Engineering Tab Page 2

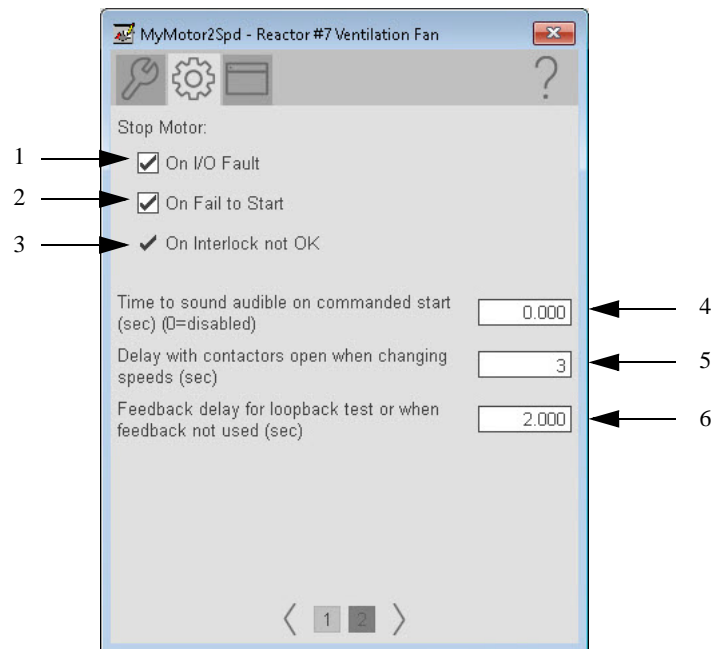
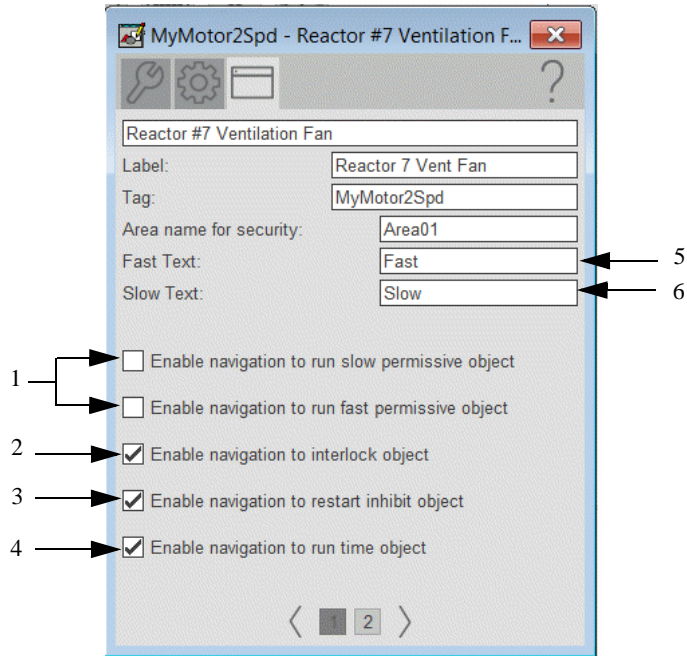


Table 183 - Engineering Page 2 Description

Item	Description
1	Check to stop the motor if an I/O fault is detected. Clear this checkbox to show only the I/O fault status/alarm and not stop the motor if an I/O fault is detected.
2	Check to stop the motor if a fail to Start fault is detected. Clear this checkbox to show only the Fail to Start status/alarm and not stop the motor if a fail to Start fault is detected.
3	The motor always stops on an interlock not ok. This item cannot be cleared. It is displayed as a reminder that the Interlock not OK function always trips the motor.
4	Type the amount of time to sound the audible alarm when the motor starts.
5	Type the time delay between when the run output has turned off for one speed and when it is turned on for the other speed.
6	Type the time delay (in seconds) for the running or stopped status to be echoed back when the simulation is enabled or when run feedback is not used.

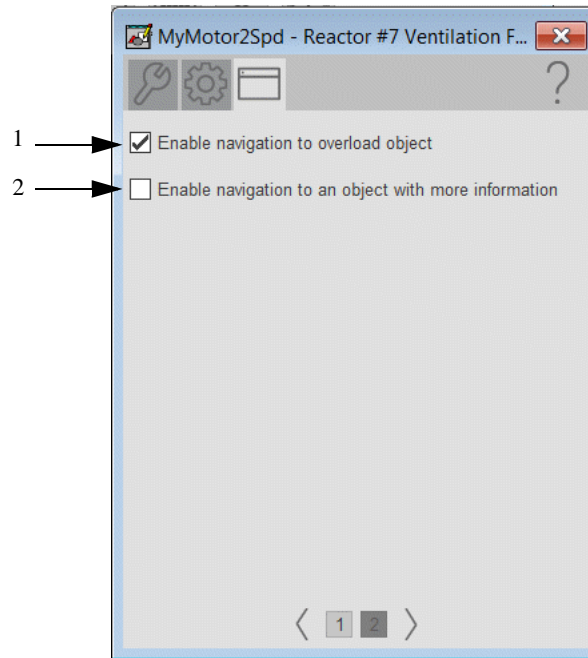
### HMI Configuration Tab

The HMI configuration tab provides access to displayed text, and faceplate-to-faceplate navigation settings. Configure the description, label, tag, and security area for the device. See [Basic Faceplate Attributes on page 32](#) for the description of the common attributes.



**Table 184 - HMI Configuration Page 1 Description**

Item	Description
1	Check if a run slow or run fast permissive object is used with this motor. <b>IMPORTANT:</b> The name of the Slow or Fast Permissive object in the controller must be the name of the object with the suffix ‘_FastPerm’ or ‘_SlowPerm’. For example, if your P_Motor2Spd object has the name ‘Motor123’, then its Slow Permissive object must be named ‘Motor123_SlowPerm’ or its Fast Permissive object must be named ‘Motor123_FastPerm’.
2	Check if an interlock object is used with this motor. <b>IMPORTANT:</b> The name of the Interlock object in the controller must be the name of the object with the suffix ‘_Intlk’. For example, if your P_Motor2Spd object has the name ‘Motor123’, then its Interlock object must be named ‘Motor123_Intlk’.
3	Check if a restart inhibit object is used with this motor. <b>IMPORTANT:</b> The name of the Restart Inhibit object in the controller must be the name of the object with the suffix ‘_ResInh’. For example, if your P_Motor2Spd object has the name ‘Motor123’, then its Restart Inhibit object must be named ‘Motor123_ResInh’.
4	Check if a run time object is used with this motor. <b>IMPORTANT:</b> The name of the Run Time object in the controller must be the name of the object with the suffix ‘_RunTime’. For example, if your P_Motor2Spd object has the name ‘Motor123’, then its Run Time object must be named ‘Motor123_RunTime’.
5	Type the text to display when the motor is running fast.
6	Type the text to display when the motor is running slow.



### HMI Configuration Page 2 Description

Item	Description
1	<p>Check if an overload object is used with this motor.</p> <p><b>IMPORTANT:</b> The name of the Overload object in the controller must be the name of the object with the suffix ‘_Ovld’. For example, if your P_Motor2Spd object has the name ‘Motor123’, then its Overload object must be named ‘Motor123_Ovld’.</p>
2	<p>Check to enable navigation to an object with more information (Cfg_HasMoreObj is set to true.)</p> <p>This can be configured to navigate to an AOI backing tag or a UDT tag that has HMI_Type and HMI_Lib defined.</p> <p>For example, there is a motor with the tag name P_101 and there is a need to have the more information button navigate to the parent P_LLS object. A tag is created for the P_LLS object that is given the alias P101_More. When the more information button is pressed on the motor, it links to P101_More. This will open the faceplate for the LLS object.</p>

## Diagnostics Tab

The Diagnostic tab provides indications that are helpful to diagnose or help prevent device problems. The device problems can include specific reasons a device is 'Not Ready', device warnings and faults, warning and fault history, and predictive/preventive maintenance data.

The Diagnostics tab displays possible reasons for the device not being ready. See [Diagnostics Tab on page 36](#)

## Alarms Tab

The Alarms tab displays each configured alarm. The icon on the tab for the alarms page changes color to show the current active alarm status. A blinking alarm icon indicates that one or more alarms must be acknowledged or the device must be reset. See [Common Alarm Block \(P\\_Alarm\) on page 66](#) for more information.

## **Reversing Motor (P\_MotorRev)**

The P\_MotorRev (Reversing Motor) Add-On Instruction controls a reversing motor (forward/reverse/stopped) in various command sources and monitors for fault conditions.

This document is for the visualization files, display elements, global objects, and HMI information. The operation of the Add-on Instructions and controller code is contained in publication [PROCES-RM013](#).

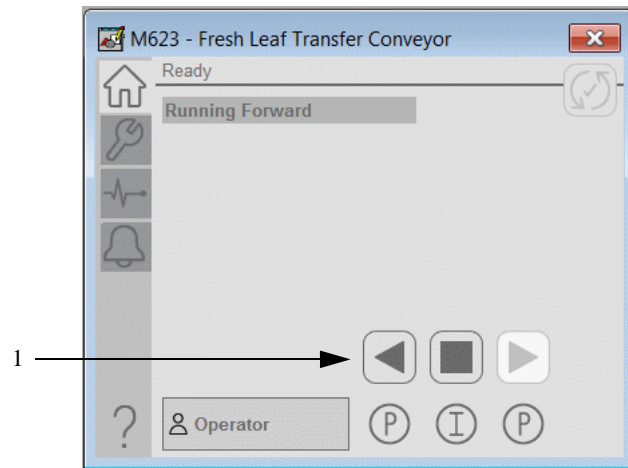
### **Display Elements (P\_MotorRev)**

A display element (global object) is created once and can be referenced multiple times on multiple displays in an application. When changes are made to the original (base) object, the instantiated copies (reference objects) are automatically updated. Use of global objects, with tag structures in the ControlLogix system, aid consistency and save engineering time. P\_MotorRev uses the same Display Elements as P\_Motor. See [Display Elements \(P\\_Motor\) on page 250](#)

## Operator Tab

The Faceplate initially opens to the Operator (Home) tab. From here, an operator can monitor the device status and manually operate the device when it is in Operator command source. Several features are common to all Add-On Instructions faceplates for the motors family. See [Common Operator Tab - Motors on page 247](#).

This instruction also includes a reverse button.



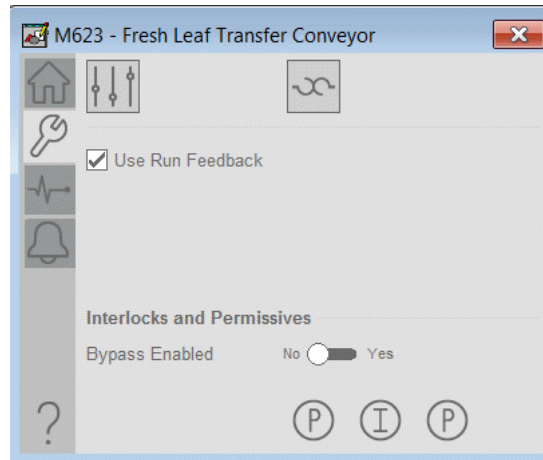
**Table 185 - Operator Tab Description**

Item	Description
1	Click to start motor in reverse direction.

## Maintenance Tab

Maintenance personnel use the information and controls on the Maintenance tab to adjust device parameters, troubleshoot, temporarily work around device problems, and disable the device for routine maintenance. Several features are common to all Add-On Instructions faceplates for the motors family.

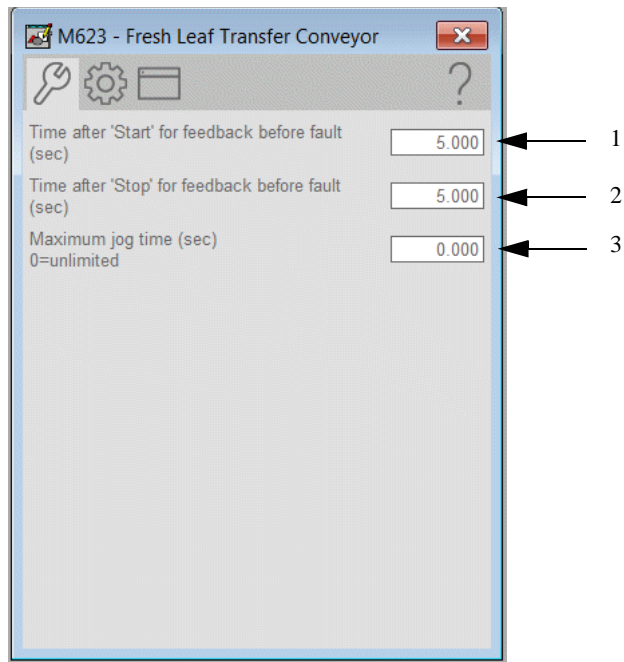
See [Common Maintenance Tab - Motors on page 248](#)



## Advanced Properties Display

The Advanced Properties Display opens to the advanced maintenance settings. The Advanced Properties Display provides access to device configuration parameters and ranges, and options for device and I/O setup. This tab is used for initial system commissioning or later system changes.

### Advanced Maintenance Tab



**Table 186 - Advanced Maintenance Tab Description**

Item	Description
1	Type the time, in seconds, to allow the run feedback to show that the motor has started before raising a fail to start alarm.
2	Type the time, in seconds, to allow the run feedback to show that the motor has stopped before raising a fail to stop alarm.
3	Type the time, in seconds, for the maximum jog time for the motor.



## Engineering Tab

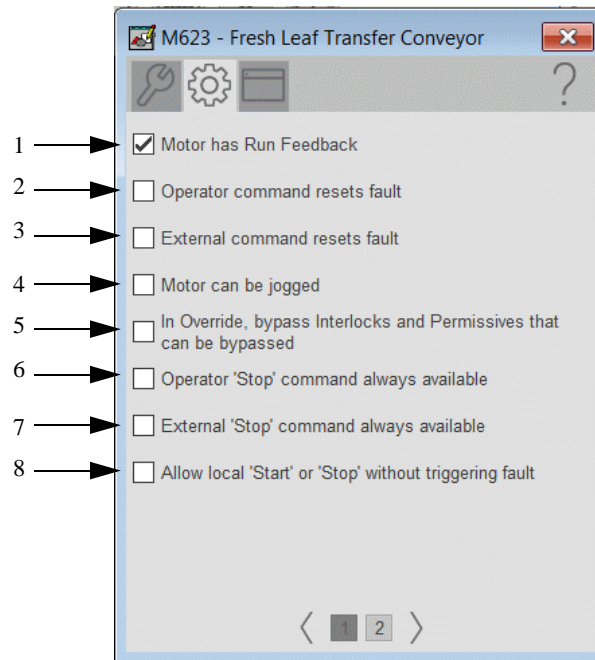
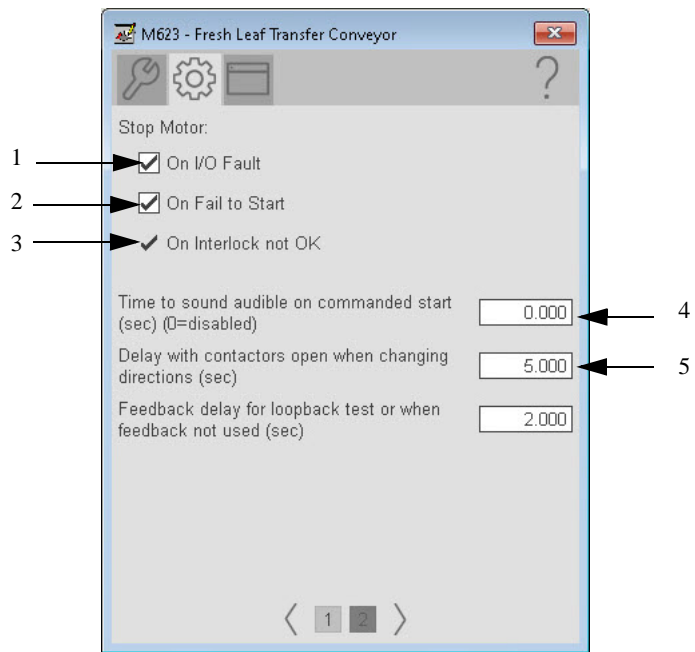


Table 187 - Engineering Page 1 Description

Item	Description
1	Check if the motor provides run feedback to Inp_SlowRunFdbk and Inp_FastRunFdbk. Clear this checkbox if there is no run feedback. <b>IMPORTANT:</b> This check places the device in Maintenance Bypass unless 'Use Run Feedback' on the Maintenance tab is checked.
2	Check to allow the Operator commands for Start Slow, Start Fast, or Stop, to reset any previous faults (I/O fault, Fail to Start, Fail to Stop, Interlock Trip). Then start or stop motor. Clear this checkbox to reset faults only using the reset code.
3	Check to allow the External commands for Start Slow, Start Fast, or Stop, to reset any previous faults (I/O fault, Fail to Start, Fail to Stop, Interlock Trip). Then start or stop motor. Clear this checkbox to reset faults only using the reset code.
4	Check to allow motor to be jogged.
5	Check to bypass bypassable interlocks and permissives in Override command source.
6	Check to have the Operator Stop command available in any command source. Clear this checkbox to have the Operator Stop command available only in the Operator and Maintenance command sources.
7	Check to have the External Stop command available in any command source. Clear this checkbox to have the External Stop command available only in the Operator and Maintenance command sources.
8	Check to allow local Start/Stop without alarm. Clear this checkbox to allow start/stop only using Program or Operator commands or Override Logic.

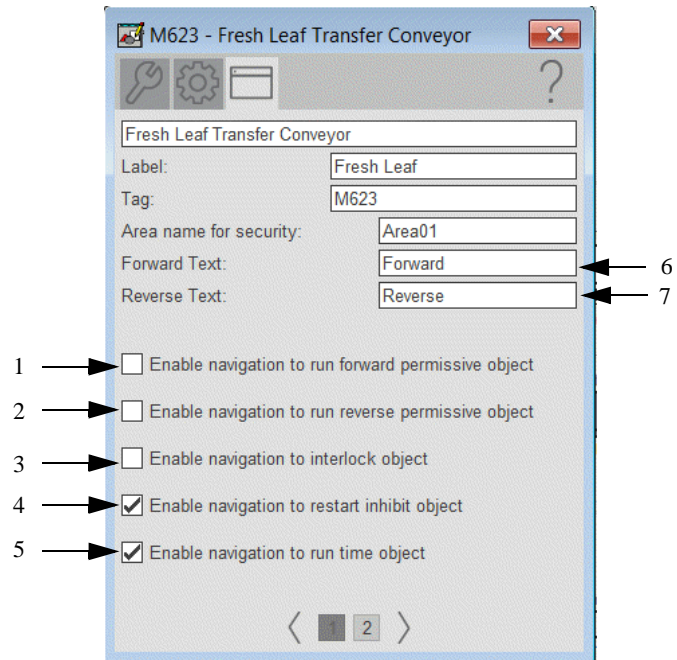


**Table 188 - Engineering Page 2 Description**

Item	Description
1	Check to stop the motor if an I/O fault is detected. Clear this checkbox to show only the I/O fault status/alarm and not stop the motor if an I/O fault is detected.
2	Check to stop the motor if a fail to Start fault is detected. Clear this checkbox to show only the Fail to Start status/alarm and not stop the motor if a fail to Start fault is detected.
3	The motor always stops on an interlock not ok. This item cannot be unchecked. It is displayed as a reminder that the Interlock not OK function always trips the motor.
4	Type the time (in seconds) the audible alarm sounds on a commanded start.
5	Set the time delay (in seconds) for running or stopped status to be echoed back when the simulation is enabled or when run feedback is not used.

## HMI Configuration Tab

The HMI configuration tab provides access to displayed text, and faceplate-to-faceplate navigation settings. Configure the description, label, tag, and security area for the device. See [Basic Faceplate Attributes on page 32](#) for the description of the common attributes.

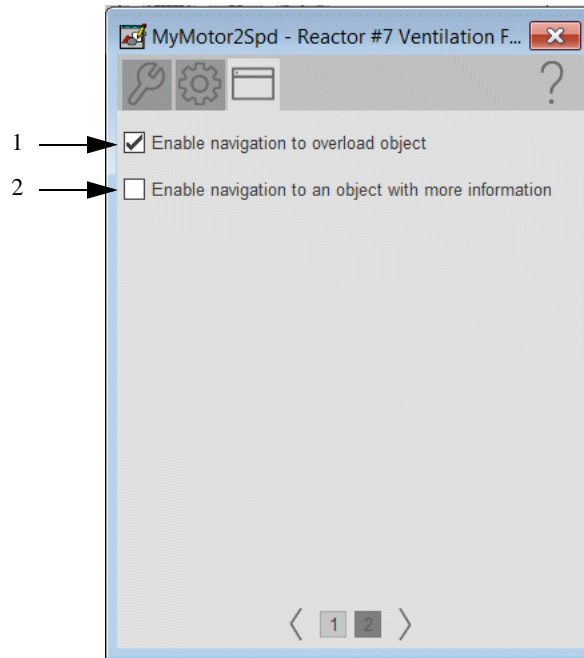


**Table 189 - HMI Configuration Page 1 Description**

Item	Description
1	<p>Check if a run forward permissive object is used with this motor. This check changes the Permissive indicator to a clickable button to open the Permissive faceplate.</p> <p><b>IMPORTANT:</b> The name of the Permissive object in the controller must be the name of the object with the suffix '_Perm'. For example, if your P_Motor object has the name 'Motor123', then its Permissive object must be named 'Motor123_Perm'.</p>
2	<p>Check if a run reverse Permissive object is used with this motor. This check changes the Permissive indicator to a clickable button to open the Permissive faceplate.</p> <p><b>IMPORTANT:</b> The name of the Permissive object in the controller must be the name of the object with the suffix '_Perm'. For example, if your P_Motor object has the name 'Motor123', then its Permissive object must be named 'Motor123_Perm'.</p>
3	<p>Check if an Interlock object is used with this motor. This check changes the Interlock indicator to a clickable button to open the Interlock faceplate.</p> <p><b>IMPORTANT:</b> The name of the Interlock object in the controller must be the name of the object with the suffix '_Intlk'. For example, if your P_Motor object has the name 'Motor123', then its Interlock object must be named 'Motor123_Intlk'.</p>
4	<p>Check if a Restart Inhibit object is used with this motor. This check makes the Restart Inhibit button visible.</p> <p><b>IMPORTANT:</b> The name of the Restart Inhibit object in the controller must be the name of the object with the suffix '_ResInh'. For example, if your P_Motor object has the name 'Motor123', then its Restart Inhibit object must be named 'Motor123_ResInh'.</p>

**Table 189 - HMI Configuration Page 1 Description**

Item	Description
5	Check if a RunTime object is used with this motor. This check makes the Run Time button visible. <b>IMPORTANT:</b> The name of the RunTime object in the controller must be the name of the object with the suffix '_RunTime'. For example, if your P_Motor object has the name 'Motor123', then its Run Time object must be named 'Motor123_RunTime'.
6	Type the text to display when the motor is running forward.
7	Type the text to display when the motor is running reverse.



**Table 190 - HMI Configuration Page 2 Description**

Item	Description
1	Check if an Overload object is used with this motor. This check makes the Overload button visible. <b>IMPORTANT:</b> The name of the Overload object in the controller must be the name of the object with the suffix '_Ovld'. For example, if your P_Motor object has the name 'Motor123', then its Overload object must be named 'Motor123_Ovld'
2	Check to enable navigation to an object with more information (Cfg_HasMoreObj is set to true.) This can be configured to navigate to an AOI backing tag or a UDT tag that has HMI_Type and HMI_Lib defined. For example, there is a motor with the tag name P_101 and there is a need to have the more information button navigate to the parent P_LLS object. A tag is created for the P_LLS object that is given the alias P101_More. When the more information button is pressed on the motor, it links to P101_More. This will open the faceplate for the LLS object.

## **Diagnostics Tab**

The Diagnostic tab provides indications that are helpful to diagnose or help prevent device problems. The device problems can include specific reasons a device is 'Not Ready', device warnings and faults, warning and fault history, and predictive/preventive maintenance data.

The Diagnostics tab displays possible reasons for the device not being ready. See [Diagnostics Tab on page 36](#)

## **Alarms Tab**

The Alarms tab displays each configured alarm. The icon on the tab for the alarms page changes color to show the current active alarm status. A blinking alarm icon indicates that one or more alarms must be acknowledged or the device must be reset. See [Common Alarm Block \(P\\_Alarm\) on page 66](#) for more information.

## **Hand-operated Motor (P\_MotorHO)**

The P\_MotorHO (Hand-operated Motor) Add-On Instruction monitors a locally controlled (hand-operated) motor.

This document is for the visualization files, display elements, global objects, and HMI information. The operation of the Add-on Instructions and controller code is contained in publication [PROCES-RM013](#).

### **Display Elements (P\_MotorHO)**

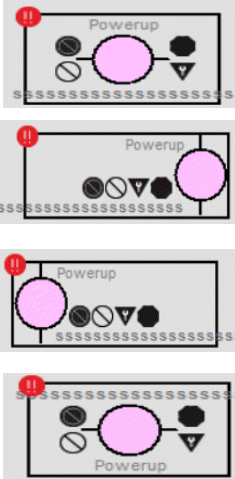
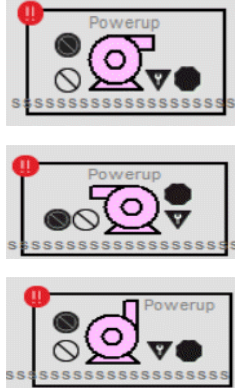


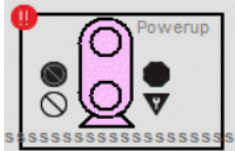

A display element (global object) is created once and can be referenced multiple times on multiple displays in an application. When changes are made to the original (base) object, the instantiated copies (reference objects) are automatically updated. Use of global objects, with tag structures in the ControlLogix system, aid consistency and save engineering time.

The P\_MotorHO instruction has graphic symbols for motors, blowers, agitators, and pumps for use on process graphic displays.

Table 191 - P\_MotorHO Display Elements

Display Element Name	Display Element	Description
GO_P_MotorHO_R GO_P_MotorHO_U GO_P_MotorHO_D		Motors operating in different positions.
GO_P_MotorHO_Blower_R GO_P_MotorHO_Blower_L GO_P_MotorHO_Blower_U GO_P_MotorHO_Blower_D		Blowers operating in different positions.
GO_P_MotorHO_Conveyor_R		Conveyor shown as a display element.

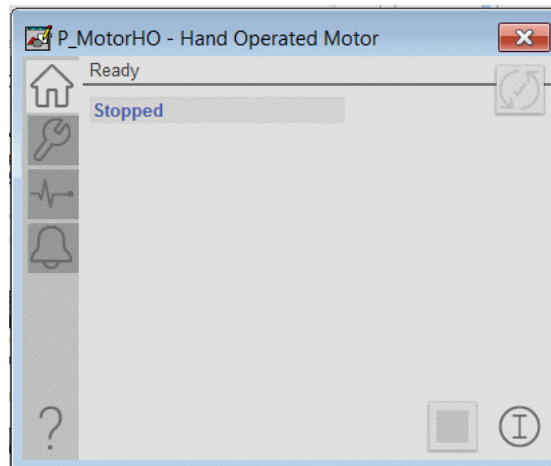
**Table 191 - P\_MotorHO Display Elements**

Display Element Name	Display Element	Description
GO_P_MotorHO_Inline_U GO_P_MotorHO_Inline_R GO_P_MotorHO_Inline_L GO_P_MotorHO_Inline_D		Inline motors operating in different positions.
GO_P_MotorHO_Pump_R GO_P_MotorHO_Pump_L GO_P_MotorHO_Pump_U		Pumps operating in different positions.
GO_P_MotorHO_Agitator_D		Agitator shown as a display element.
GO_P_MotorHO_Mixer_U		Mixer shown as a display element.
GO_P_MotorHO_RPump_U		Rotary gear pump shown as a display element.
GO_P_MotorHO_Fan_D		Fan shown as a display element.



## Operator Tab

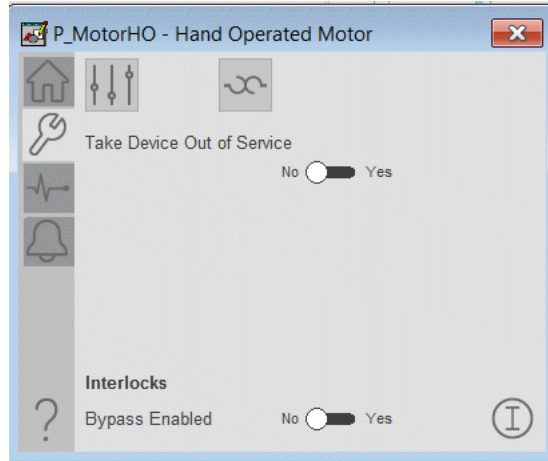
The Faceplate initially opens to the Operator (Home) tab. From here, an operator can monitor the device status and manually operate the device when it is in Operator command source. Several features are common to all Add-On Instructions faceplates for the motors family. See [Common Operator Tab - Motors on page 247](#).



## Maintenance Tab

Maintenance personnel use the information and controls on the Maintenance tab to adjust device parameters, troubleshoot, temporarily work around device problems, and disable the device for routine maintenance. Several features are common to all Add-On Instruction faceplates for the motors family.

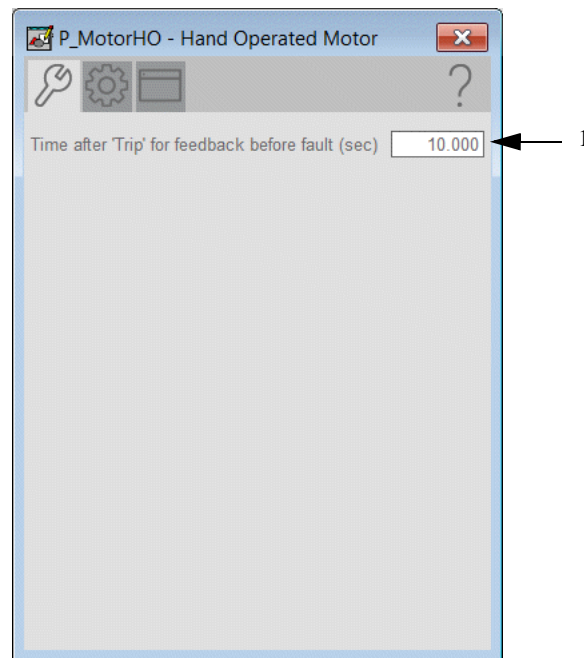
See [Common Maintenance Tab - Motors on page 248](#)



## Advanced Properties Display

The Advanced Properties Display opens to the advanced maintenance settings. The Advanced Properties Display provides access to device configuration parameters and ranges, and options for device and I/O setup. This tab is used for initial system commissioning or later system changes.

### *Advanced Maintenance Tab*



**Table 192 - Advanced Maintenance Tab Description**

Item	Description
1	Enter the amount of time to allow motor run feedback to show that the motor stopped after a trip is commanded. If the motor does not show stopped in the allowed time, a Trip Fail alarm is raised.

Engineering Tab

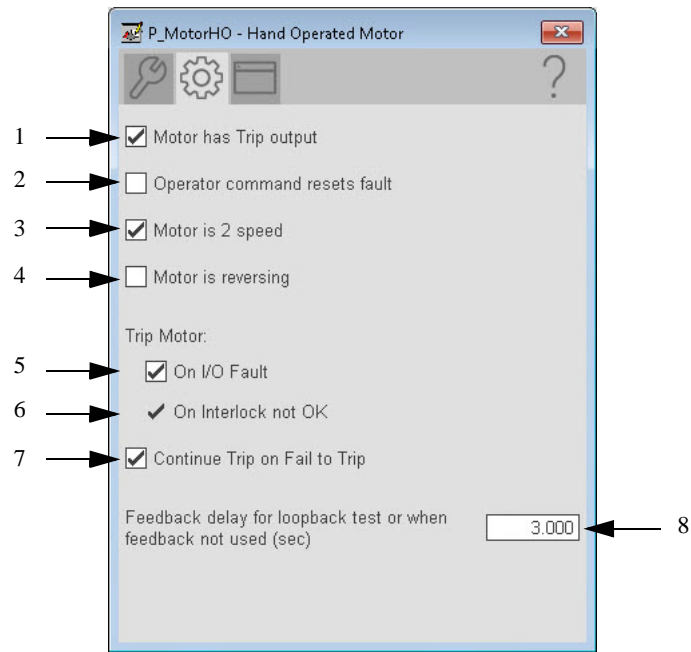
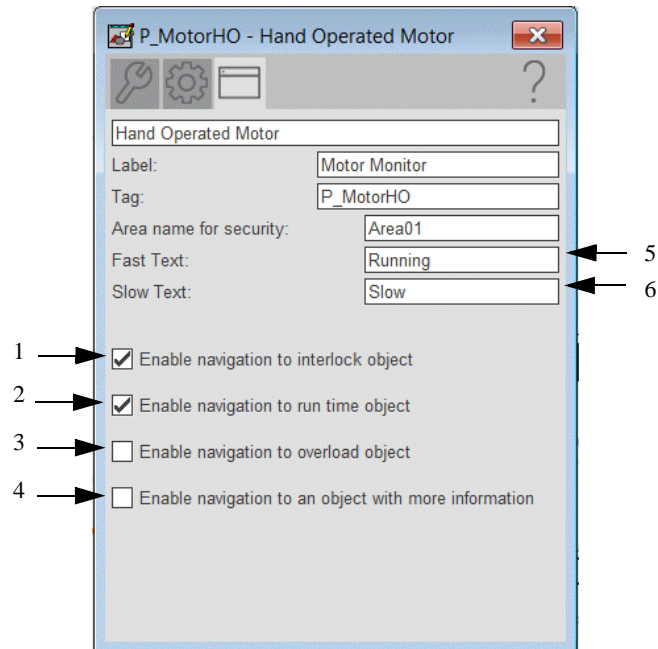


Table 193 - Engineering Tab Description

Item	Description
1	Check if a trip output is connected to the P_MotorHO instruction to stop the motor on an interlock or trip command. This check makes the trip (stop) command button visible on the Operator tab.
2	Check to allow the operator trip command to reset any previous faults (I/O fault, fail to trip, interlock trip) then trip motor. Clear this checkbox to reset faults by using only the reset command.
3	Check for a two speed (fast/slow) motor. <b>IMPORTANT:</b> This option is unavailable if 'Motor is reversing' is checked. Clear this checkbox for a reversing motor or a single-speed motor.
4	Check for a reversing (forward/reverse) motor. <b>IMPORTANT:</b> This option is unavailable if 'Motor is 2 speed' is checked. Clear this checkbox for a two-speed motor or a single-speed motor.
5	Check to send the trip output to the motor if an I/O fault is detected. Clear this checkbox to show only the I/O fault status/alarm and not trip the motor if an I/O fault is detected.
6	The motor always trips on an Interlock not OK. This item cannot be unchecked. It is displayed as a reminder that the interlock not OK function always trips the motor.
7	Check to keep sending the trip output to the motor on a trip, even if position feedback does not confirm the motor stopped. Clear this checkbox to stop sending the trip output to the motor when the motor trip times out and the fail to trip status is set.
8	Type the amount of time (in seconds) the motor status shows tripping before showing a stopped or running status when the motor is tripped and the I/O are being simulated (Inp_Sim = 1).

## HMI Configuration Tab

The HMI configuration tab provides access to displayed text, and faceplate-to-faceplate navigation settings. Configure the description, label, tag, and security area for the device. See [Basic Faceplate Attributes on page 32](#) for the description of the common attributes.



**Table 194 - HMI Configuration Tab Description**

Item	Description
1	Check if an interlock object is connected to Inp_Intlk. This check changes the interlock indicator on the Operator tab to a button that opens the interlocks faceplate. <b>IMPORTANT:</b> The name of the Interlock object in the controller must be the name of the object with the suffix '_Intlk'. For example, if your P_MotorHO object has the name 'MotorHO123', then its Interlock object must be named 'MotorHO123_Intlk'.
2	Check if a Run Time instruction is connected to the status of this instruction for accumulating total motor run time and number of starts. This check displays the 'hour meter' button, which opens the run time faceplate, visible on the Operator tab. <b>IMPORTANT:</b> The name of the Run Time object in the controller must be the name of the object with the suffix '_RunTime'. For example, if your P_MotorHO object has the name 'MotorHO123', then its Run Time object must be named 'MotorHO123_RunTime'.
3	Check if an Overload object is connected. This check displays the button, which opens the Overload faceplate, visible on the Operator tab. <b>IMPORTANT:</b> The name of the Overload object in the controller must be the name of the object with the suffix '_Ovld'. For example, if your P_MotorHO object has the name 'MotorHO123', then its Overload object must be named 'MotorHO123_Ovld'.

Item	Description
4	<p>Check to enable navigation to an object with more information (Cfg_HasMoreObj is set to true.)</p> <p>This can be configured to navigate to an AOI backing tag or a UDT tag that has HMI_Type and HMI_Lib defined.</p> <p>For example, there is a motor with the tag name P_101 and there is a need to have the more information button navigate to the parent P_LLS object. A tag is created for the P_LLS object that is given the alias P101_More. When the more information button is pressed on the motor, it links to P101_More. This will open the faceplate for the LLS object.</p>
5	Type the text to show after 'running' when a 2-speed motor is running fast.
6	Type the text to show after 'running' when a 2-speed motor is running slow.

## **Diagnostics Tab**

The Diagnostic tab provides indications that are helpful to diagnose or help prevent device problems. The device problems can include specific reasons a device is 'Not Ready', device warnings and faults, warning and fault history, and predictive/preventive maintenance data.

The Diagnostics tab displays possible reasons for the device not being ready. See [Diagnostics Tab on page 36](#)

## **Alarms Tab**

The Alarms tab displays each configured alarm. The icon on the tab for the alarms page changes color to show the current active alarm status. A blinking alarm icon indicates that one or more alarms must be acknowledged or the device must be reset. See [Common Alarm Block \(P\\_Alarm\) on page 66](#) for more information.

## Discrete 2-, 3-, 4-state Device (P\_D4SD)

The P\_D4SD (Discrete 2-, 3-, 4-state Device) Add-On Instruction controls and monitors feedback from a discrete 2-state, 3-state, or 4-state device in various command sources, monitoring for fault conditions. These devices include multiple-speed motors or multiple-position valves.

This document is for the visualization files, display elements, global objects, and HMI information. The operation of the Add-on Instructions and controller code is contained in publication [PROCES-RM013](#).

### Display Elements (P\_D4SD)

A display element (global object) is created once and can be referenced multiple times on multiple displays in an application. When changes are made to the original (base) object, the instantiated copies (reference objects) are automatically updated. Use of global objects, with tag structures in the ControlLogix system, aid consistency and save engineering time.

**Table 195 - P\_D4SD Display Elements Description**

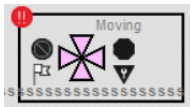

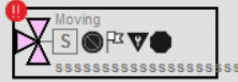
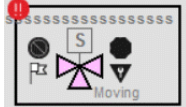

Display Element Name	Display Element	Description
GO_P_D4SD_4Way		<p>Three/Four-Way Valve.</p> <p>The Three/Four-way Valve parameters define the inlet and output ports of the valve:</p> <ul style="list-style-type: none"> <li>No. 110 - Top port open state</li> <li>No. 111 - Right port open state</li> <li>No. 112 - Bottom port open state</li> <li>No. 113 - Left port open state</li> </ul> <ul style="list-style-type: none"> <li>0 = Inlet (always shown as open)</li> <li>1 = Open when Val_Sts = 1 (state 0)</li> <li>2 = Open when Val_Sts = 2 (state 1)</li> <li>3 = Open when Val_Sts = 3 (state 2)</li> <li>4 = Open when Val_Sts = 4 (state 3)</li> </ul>
GO_P_D4SD_3Way_SO Rt		<p>Two-Way Solenoid-operated Diverter Valve in different positions: right, left, bottom, and top.</p> <p>Parameters define the inlet and output ports of the Two-way Solenoid-operated Diverter Valve.</p>
GO_P_D4SD_3Way_SO Lt		
GO_P_D4SD_3Way_SO Btm		
GO_P_D4SD_3Way_SO Top		



Table 195 - P\_D4SD Display Elements Description

Display Element Name	Display Element	Description
GO_P_D4SD_Diverter		Two Way Diverter Valve in open top-left and open top-right positions.
GO_P_D4SD_Diverter1		The Two-way Diverter Valve parameters define the state of the valve: <ul style="list-style-type: none"> <li>• State 0: Open top-left</li> <li>• State 1: Open top-right</li> <li>• State 2: —</li> <li>• State 3: —</li> </ul>
GO_P_D4SD_3WayMO_Rt		Two-Way Motor-operated Diverter Valve in different positions: right, left, bottom, and top.
GO_P_D4SD_3WayMO_Lt		Parameters define the inlet and output ports of the Two-way Motor-operated Diverter Valve.
GO_P_D4SD_3WayMO_Btm		
GO_P_D4SD_3WayMO_Top		
GO_P_D4SD_R		Motors in different positions: right, up, and down.
GO_P_D4SD_U		
GO_P_D4SD_D		

**Table 195 - P\_D4SD Display Elements Description**




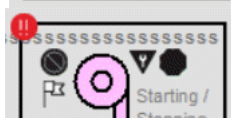
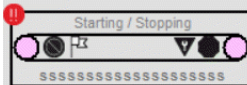

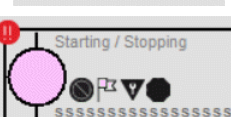

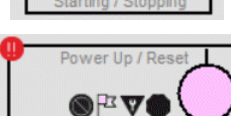
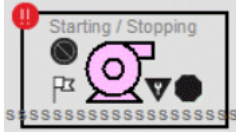
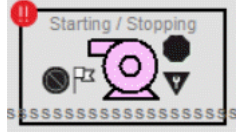
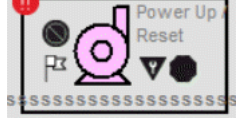


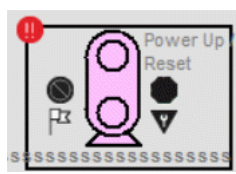
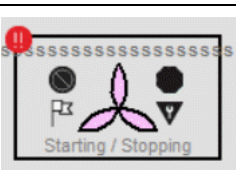
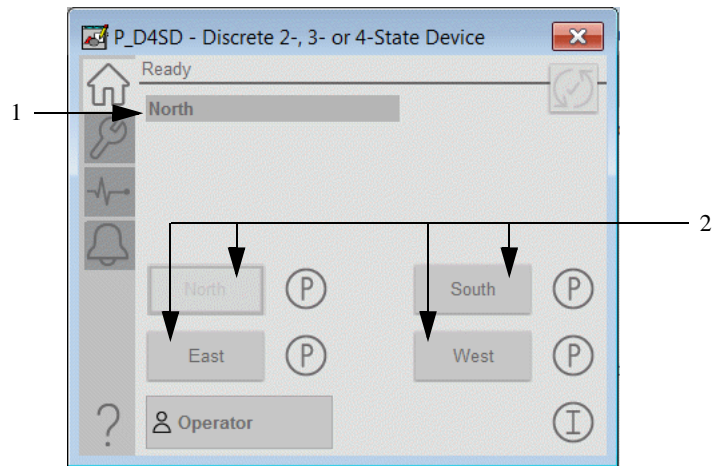
Display Element Name	Display Element	Description
GO_P_D4SD_Blower_R		Blowers in different positions: right, left, up, and down.
GO_P_D4SD_Blower_L		
GO_P_D4SD_Blower_U		
GO_P_D4SD_Blower_D		
GO_P_D4SD_Conveyor-R		Conveyor
GO_P_D4SD_Inline_U		Inline Motors in different positions: up, left, down, and right.
GO_P_D4SD_Inline_L		
GO_P_D4SD_Inline_D		
GO_P_D4SD_Inline_R		

Table 195 - P\_D4SD Display Elements Description

Display Element Name	Display Element	Description
GO_P_D4SD_Pump_R		Pumps in different positions: right, left, and up.
GO_P_D4SD_Pump_L		
GO_P_D4SD_Pump_U		
GO_P_D4SD_Agitator_D		Agitator in down position.
GO_P_D4SD_Mixer_U		Mixer in up position.
GO_P_D4SD_RPump_U		Rotary Gear Pump in up position.
GO_P_D4SD_Fan_D		Fan in down position.

## Operator Tab

The Faceplate initially opens to the Operator (Home) tab. From here, an operator can monitor the device status and manually operate the device when it is in Operator command source. Several features are common to all Add-On Instructions faceplates for the motors family. See [Common Operator Tab - Motors on page 247](#).



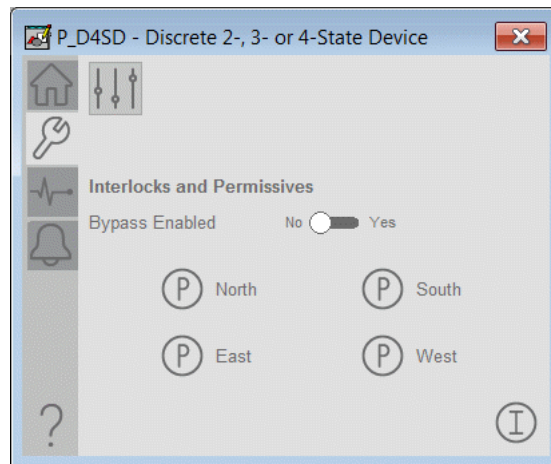
**Table 196 - Operator Tab Description**

Item	Description
1	Device state indicator
2	Move to state command buttons

## Maintenance Tab

Maintenance personnel use the information and controls on the Maintenance tab to adjust device parameters, troubleshoot, temporarily work around device problems, and disable the device for routine maintenance. Several features are common to all Add-On Instructions faceplates for the motors family.

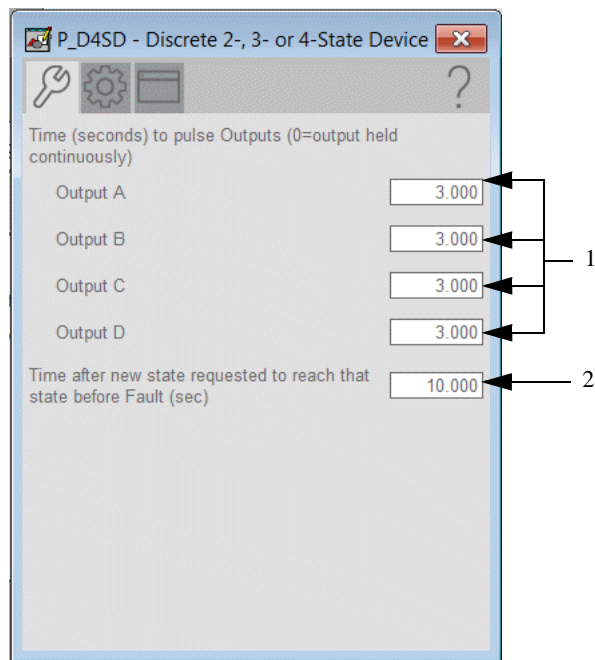
See [Common Maintenance Tab - Motors on page 248](#)



## Advanced Properties Display

The Advanced Properties Display opens to the advanced maintenance settings. The Advanced Properties Display provides access to device configuration parameters and ranges, and options for device and I/O setup. This tab is used for initial system commissioning or later system changes.

### Advanced Maintenance Tab

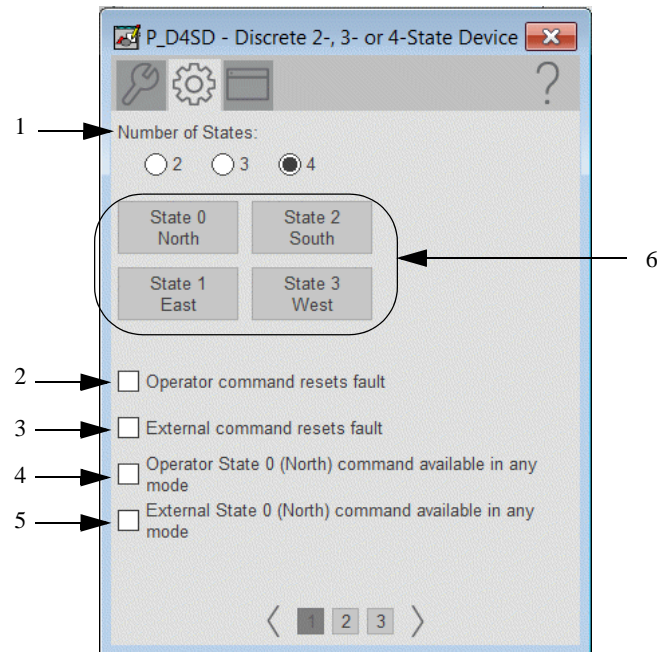


**Table 197 - Advanced Maintenance Tab Description**

Item	Description
1	Type a value (0...2,147,483.647) to indicate the time (seconds) to energize outputs to the device to be sure that they are latched in. (0 = output held continuously)
2	Type a value (0...2,147,483.647) to indicate the time (seconds) to allow the device to reach the commanded state before issuing a fault.

## Engineering Tab

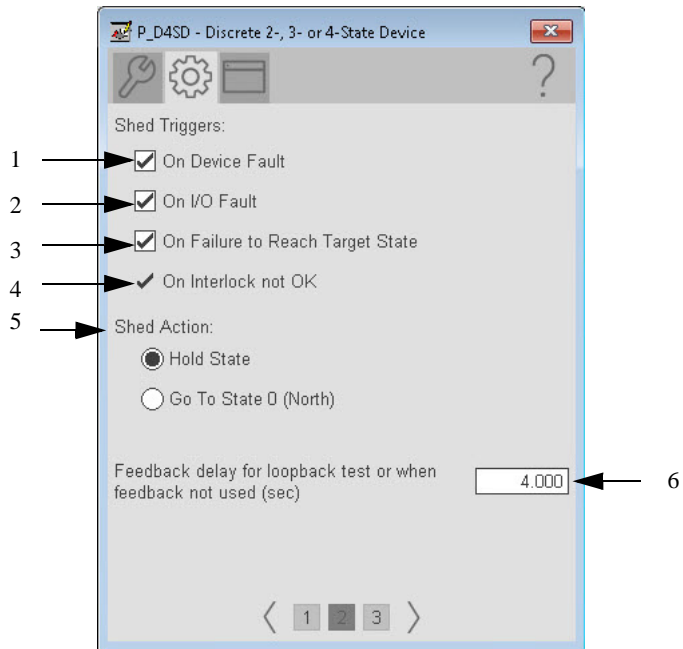
The engineering tab is divided into three pages.



**Table 198 - Engineering Page 1 Description**

Item	Description
1	Click to select the number of states.
2	Check to reset a fault upon a new operator command.
3	Check to reset a fault upon a new external command.

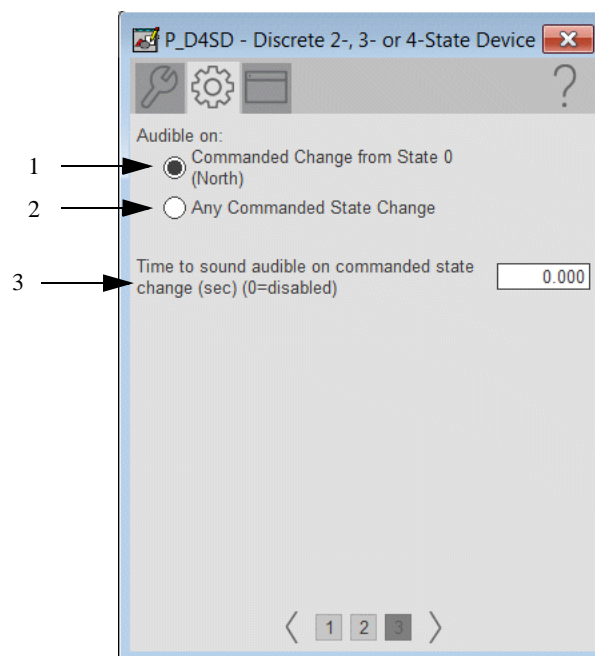
Item	Description																								
4	<p>Check (= 1) to make Operator State 0 (OCmd_St0) available in any command source.</p> <p>Clear this checkbox (= 0) to make Operator State 0 (OCmd_St0) available only in Operator or Maintenance command source.</p>																								
5	<p>Check (= 1) to make External State 0 (XCmd_St0) available in any command source.</p> <p>Clear this checkbox (= 0) to make External State 0 (XCmd_St0) available only in Operator or Maintenance command source.</p>																								
6	<p>Click a state to open the P_D4SD State Configuration display for that state.</p> <div data-bbox="867 550 1273 806" data-label="Image"> <table border="1"> <thead> <tr> <th colspan="2">Output</th> <th colspan="2">Feedback</th> </tr> <tr> <th>Write</th> <th>Value</th> <th>Reqd</th> <th>State</th> </tr> </thead> <tbody> <tr> <td><input checked="" type="checkbox"/></td> <td>1</td> <td><input checked="" type="checkbox"/></td> <td>1</td> </tr> <tr> <td><input checked="" type="checkbox"/></td> <td>0</td> <td><input checked="" type="checkbox"/></td> <td>0</td> </tr> <tr> <td><input checked="" type="checkbox"/></td> <td>0</td> <td><input checked="" type="checkbox"/></td> <td>0</td> </tr> <tr> <td><input checked="" type="checkbox"/></td> <td>0</td> <td><input checked="" type="checkbox"/></td> <td>0</td> </tr> </tbody> </table> </div> <p>This display directs how the P_D4SD instruction commands the device state via outputs and determines the actual device state via feedback inputs. The first two columns for output set parameters, Cfg_OutSt[x]Write, and Cfg_OutSt[x]Value, determine how outputs are written to command to a state. The second two columns for feedback set parameters, Cfg_FdbkSt[x]Check, and Cfg_FdbkSt[x]State, determine how the state is interpreted from the input values.</p>	Output		Feedback		Write	Value	Reqd	State	<input checked="" type="checkbox"/>	1	<input checked="" type="checkbox"/>	1	<input checked="" type="checkbox"/>	0	<input checked="" type="checkbox"/>	0	<input checked="" type="checkbox"/>	0	<input checked="" type="checkbox"/>	0	<input checked="" type="checkbox"/>	0	<input checked="" type="checkbox"/>	0
Output		Feedback																							
Write	Value	Reqd	State																						
<input checked="" type="checkbox"/>	1	<input checked="" type="checkbox"/>	1																						
<input checked="" type="checkbox"/>	0	<input checked="" type="checkbox"/>	0																						
<input checked="" type="checkbox"/>	0	<input checked="" type="checkbox"/>	0																						
<input checked="" type="checkbox"/>	0	<input checked="" type="checkbox"/>	0																						





**Table 199 - Engineering Page 2 Description**

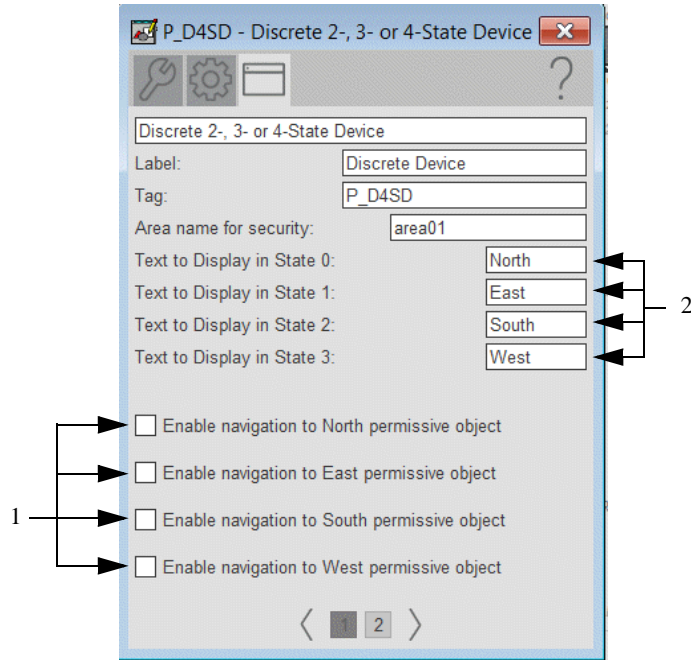
Item	Description
1	Check to shed if a Device Fault is detected.
2	Check to shed if an I/O Fault is detected.
3	Check to shed if target state is not reached.
4	The device always sheds an Interlock not OK. This item cannot be unchecked. It is displayed as a reminder that the Interlock not OK function always triggers a shed.
5	Click to determine whether you hold position or go to state 0 upon a shed condition.
6	Type a value (seconds) to indicate the delay to echo back reaching the state when in simulation.

**Table 200 - Engineering Page 3 Description**

Item	Description
1	Click to sound an audible on a commanded stage from State 0.
2	Click to sound an audible on a commanded stage from any State.
3	Type the time (in seconds) that the audible sounds when there is a commanded State change.

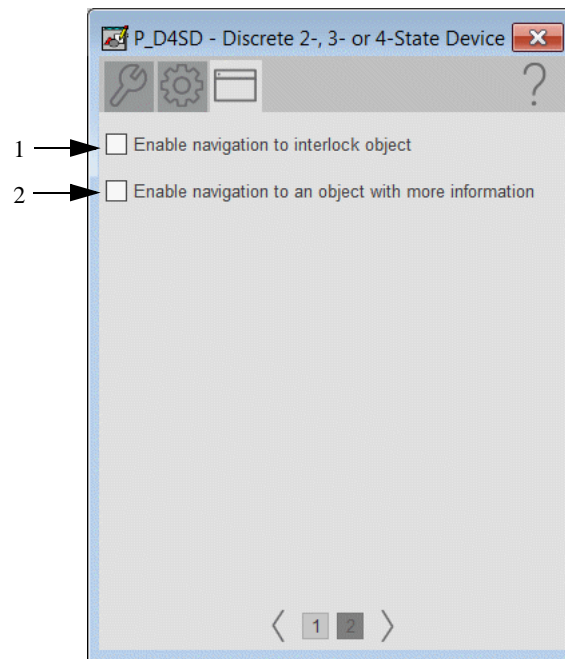
### HMI Configuration Tab

The HMI configuration tab provides access to displayed text, and faceplate-to-faceplate navigation settings. Configure the description, label, tag, and security area for the device. See [Basic Faceplate Attributes on page 32](#) for the description of the common attributes.



**Table 201 - HMI Configuration Page 1 Description**

Item	Description
1	Check if the corresponding north, south, east, or west Permissive object is used with this device. This check changes the Permissive Indicator to a button that accesses the Permissive faceplate. <b>IMPORTANT:</b> The name of the Permissives object in the controller must be the name of the object with the suffix ‘_Perm#’, where ‘#’ is the permissive number (0...3) For example, if your P_D4SD object has the name ‘D4SD123’, then its Permissives object must be named ‘D4SD123_Perm0’.
2	Type text to describe the state.



**Table 202 - HMI Configuration Page 2 Description**

Item	Description
1	<p>Check if an interlock object is connected to Inp_Intlk. This check changes the interlock indicator on the Operator tab to a button that opens the interlocks faceplate.</p> <p><b>IMPORTANT:</b> The name of the Interlock object in the controller must be the name of the object with the suffix '_Intlk'. For example, if your P_D4SD object has the name 'D4SD123', then its Interlock object must be named 'D4SD123_Intlk'.</p>
2	<p>Check to enable navigation to an object with more information (Cfg_HasMoreObj is set to true.)</p> <p>This can be configured to navigate to an AOI backing tag or a UDT tag that has HMI_Type and HMI_Lib defined.</p> <p>For example, there is a motor with the tag name P_101 and there is a need to have the more information button navigate to the parent P_LLS object. A tag is created for the P_LLS object that is given the alias P101_More. When the more information button is pressed on the motor, it links to P101_More. This will open the faceplate for the LLS object.</p>

## Diagnostics Tab

The Diagnostic tab provides indications that are helpful to diagnose or help prevent device problems. The device problems can include specific reasons a device is 'Not Ready', device warnings and faults, warning and fault history, and predictive/preventive maintenance data.

The Diagnostics tab displays possible reasons for the device not being ready. See [Diagnostics Tab on page 36](#)

## Alarms Tab

The Alarms tab displays each configured alarm. The icon on the tab for the alarms page changes color to show the current active alarm status. A blinking alarm icon indicates that one or more alarms must be acknowledged or the device must be reset. See [Common Alarm Block \(P\\_Alarm\) on page 66](#) for more information.

## Variable Speed Drive (P\_VSD)

The P\_VSD (Variable Speed Drive) Add-On Instruction is used to operate one variable speed motor by using a drive (AC variable frequency or DC) in various command sources, monitoring for fault conditions.

This document is for the visualization files, display elements, global objects, and HMI information. The operation of the Add-on Instructions and controller code is contained in publication [PROCES-RM013](#).

### Display Elements (P\_VSD)

A display element (global object) is created once and can be referenced multiple times on multiple displays in an application. When changes are made to the original (base) object, the instantiated copies (reference objects) are automatically updated. Use of global objects, with tag structures in the ControlLogix system, aid consistency and save engineering time.

**Table 203 - P\_VSD Display Elements Description**



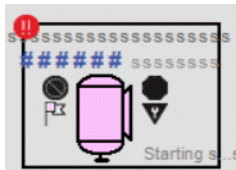
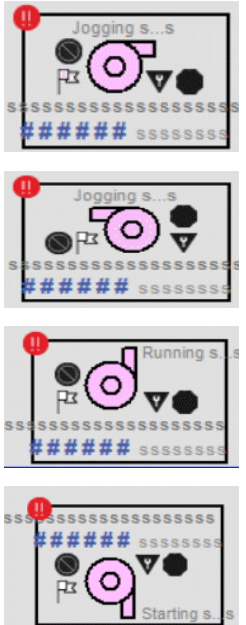


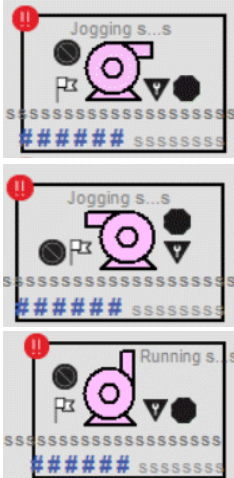

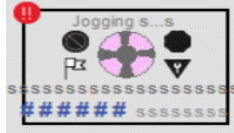


Display Element Name	Display Element	Description
GO_P_VSD		Motors operate in different positions: right, up, and down.
GO_P_VSD_1		
GO_P_VSD_4		

Table 203 - P\_VSD Display Elements Description

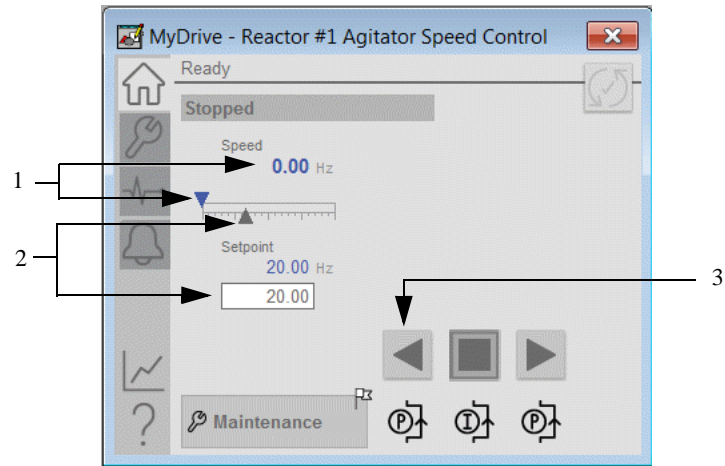
Display Element Name	Display Element	Description
<p>GO_P_VSD_Blower_1</p> <p>GO_P_VSD_Blower_2</p> <p>GO_P_VSD_Blower_3</p> <p>GO_P_VSD_Blower_4</p>		<p>Blowers operate in different positions: right, left, up, and down.</p>
<p>GO_P_VSD_Conveyer_Lt2Rt</p>		<p>Conveyor shown as a display element.</p>
<p>GO_P_VSD_Inline_1</p> <p>GO_P_VSD_Inline_2</p> <p>GO_P_VSD_Inline_3</p> <p>GO_P_VSD_Inline_4</p>		<p>Inline Motors operate in several positions: up, right, left, and down.</p>

**Table 203 - P\_VSD Display Elements Description**

Display Element Name	Display Element	Description
GO_P_VSD_Pump_1 GO_P_VSD_Pump_2 GO_P_VSD_Pump_3	 <p>The image shows three separate display elements for pumps. Each element is a square panel with a red '!!' icon in the top-left corner. The top two elements are labeled 'Jogging s...s' and show a pink pump icon with a horizontal shaft. The bottom element is labeled 'Running s...s' and shows a pink pump icon with a vertical shaft. Each panel contains various status indicators like 'Fz', a downward arrow, and a circle, along with decorative 's' and '#' characters.</p>	Pumps operate in several positions: right, left, and up.
GO_P_VSD_Agitator	 <p>The image shows a single display element for an agitator. It is a square panel with a red '!!' icon in the top-left corner. The central icon is a pink agitator with a vertical shaft. The text 'Jogging s...s' is at the bottom. The panel includes status indicators like 'Fz', a downward arrow, and a circle, along with decorative 's' and '#' characters.</p>	Agitator shown as a display element.
GO_P_VSD_Mixer	 <p>The image shows a single display element for a mixer. It is a square panel with a red '!!' icon in the top-left corner. The central icon is a pink mixer with a four-lobed impeller. The text 'Jogging s...s' is at the top. The panel includes status indicators like 'Fz', a downward arrow, and a circle, along with decorative 's' and '#' characters.</p>	Mixer shown as a display element.
GO_P_VSD_RotPump	 <p>The image shows a single display element for a rotary gear pump. It is a square panel with a red '!!' icon in the top-left corner. The central icon is a pink rotary gear pump. The text 'Running s...s' is at the top. The panel includes status indicators like 'Fz', a downward arrow, and a circle, along with decorative 's' and '#' characters.</p>	Rotary Gear Pump shown as a display element.
GO_P_VSD_Fan	 <p>The image shows a single display element for a fan. It is a square panel with a red '!!' icon in the top-left corner. The central icon is a pink fan with three blades. The text 'Jogging s...s' is at the top. The panel includes status indicators like 'Fz', a downward arrow, and a circle, along with decorative 's' and '#' characters.</p>	Fan shown as a display element.

## Operator Tab

The Faceplate initially opens to the Operator (Home) tab. From here, an operator can monitor the device status and manually operate the device when it is in Operator command source. Several features are common to all Add-On Instructions faceplates for the motors family. See [Common Operator Tab - Motors on page 247](#).



**Table 204 - Operator Tab Description**

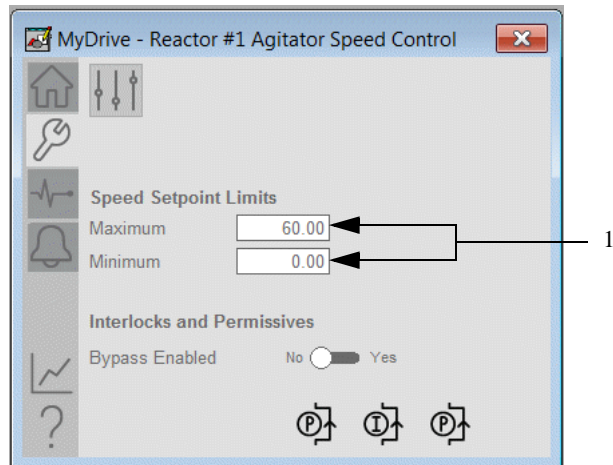
Item	Description
1	Current speed of drive
2	Setpoint for the speed of the drive
3	Start motor in reverse



## Maintenance Tab

Maintenance personnel use the information and controls on the Maintenance tab to adjust device parameters, troubleshoot, temporarily work around device problems, and disable the device for routine maintenance. Several features are common to all Add-On Instructions faceplates for the motors family.

See [Common Maintenance Tab - Motors on page 248](#)



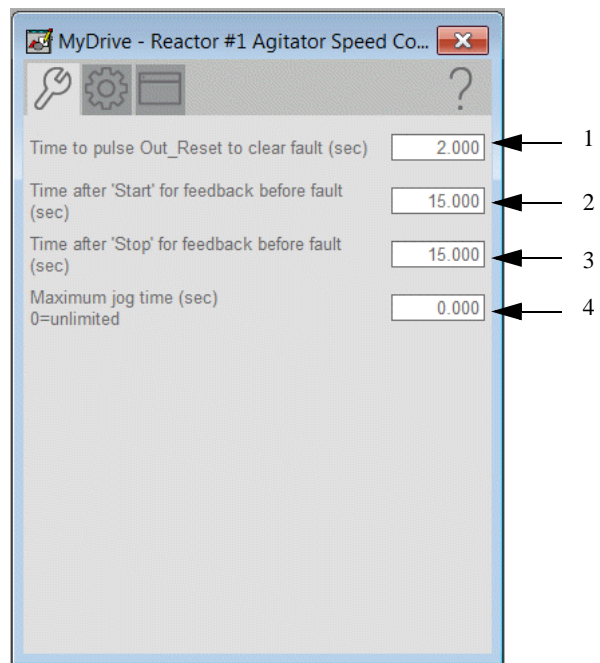
**Table 205 - Maintenance Tab Description**

Item	Description
1	Type the clamping limits for the speed setpoint. If a speed setpoint outside this range is entered, the speed is clamped at these limits and Sts_SpeedLimited is asserted.

## Advanced Properties Display

The Advanced Properties Display opens to the advanced maintenance settings. The Advanced Properties Display provides access to device configuration parameters and ranges, and options for device and I/O setup. This tab is used for initial system commissioning or later system changes.

### Advanced Maintenance Tab

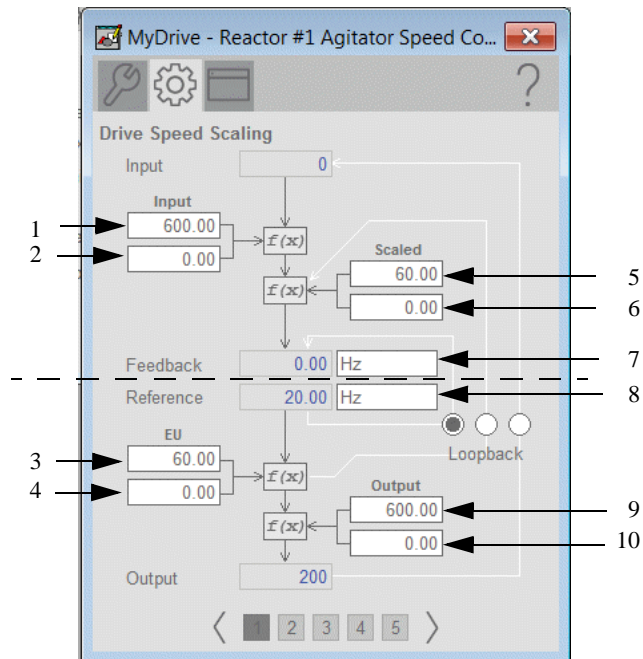


**Table 206 - Advanced Maintenance Tab Description**

Item	Description
1	Type the amount of time to hold Out_Reset true to reset a drive fault when a reset command is received.
2	Type the amount of time to allow for the run feedback on the drive to confirm that the drive has started before raising a Fail to Start alarm.
3	Type the amount of time to allow for the run feedback on the drive to confirm that the drive has stopped before raising a Fail to Stop alarm. <b>TIP:</b> Allow extra time for the drive to decelerate or coast to zero speed before it returns a confirmed Stopped status.
4	Type the maximum amount of time allowed to jog the motor.

## Engineering Tab

The engineering tab has five pages.

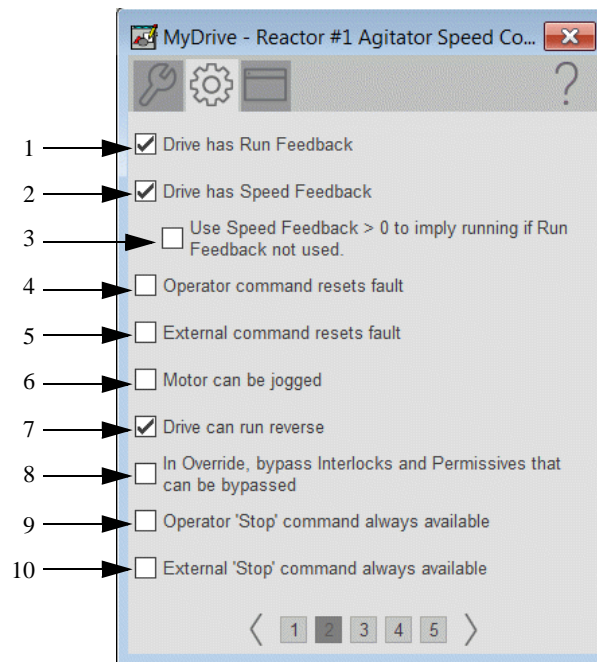


If Speed Feedback is disabled on page 2 of the Engineering tab, the Speed Feedback part (above dashed line) of the preceding image is not displayed and the loopback options are not available.

**Table 207 - Engineering Tab Page 1 Description**

Item	Description
1	Enter the raw input count that corresponds to the maximum speed feedback from the drive
2	Enter the raw input count that corresponds to the minimum speed feedback from the drive. (This value is usually zero.)
3	Enter the engineering unit value for the maximum speed reference sent to the drive.
4	Enter the engineering unit value for the minimum speed reference sent to the drive. (This value is usually zero. Do not enter a negative value for reversing drives. Reversing is handled separately.)
5	Enter the engineering unit value for the maximum speed feedback from the drive.
6	Enter the engineering unit value for the minimum speed feedback from the drive. (This value is usually zero. Do not enter a negative value for reversing drives. Reversing is handled separately.)
7	Enter the text of the units of measure of the scaled speed feedback. (Units of measure are often Hz, RPM, or Percent.)

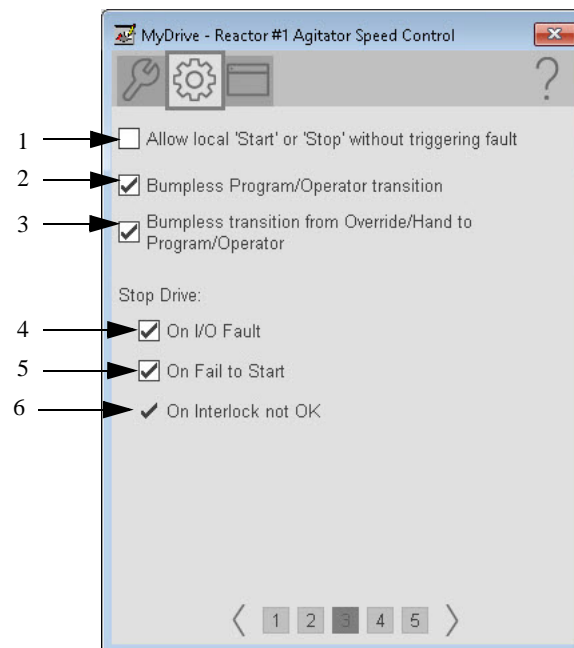
Item	Description
8	Enter the text of the units of measure of the scaled speed reference. (Units of measure are often Hz, RPM, or Percent.)
9	Enter the raw output count that corresponds to the maximum speed reference sent to the drive.
10	Enter the raw output count that corresponds to the minimum speed reference sent to the drive. (This value is usually zero.)



**Table 208 - Engineering Tab Page 2 Description**

Item	Description
1	Check if the drive provides a run feedback signal. This check enables feedback checking for Fail to Start and Fail to Stop. Clear this checkbox if there is no run feedback.
2	Check if the drive provides speed feedback on Inp_SpeedFdbk.
3	Check if Speed feedback greater than zero is used to signify the drive is running. <b>IMPORTANT:</b> This configuration setting is available only if the previous configuration setting is checked.
4	Check to reset the faults when a new operator command is issued. Clear this checkbox for 'reset required' to clear fault.
5	Check to reset the faults when a new External command is issued. Clear this checkbox for 'reset required' to clear fault.
6	Check to make the Jog command button visible on the Operator tab and enable the drive to be jogged from the faceplate.
7	Check to make the forward and reverse direction command buttons visible on the Operator tab and enable the drive to run forward or reverse.

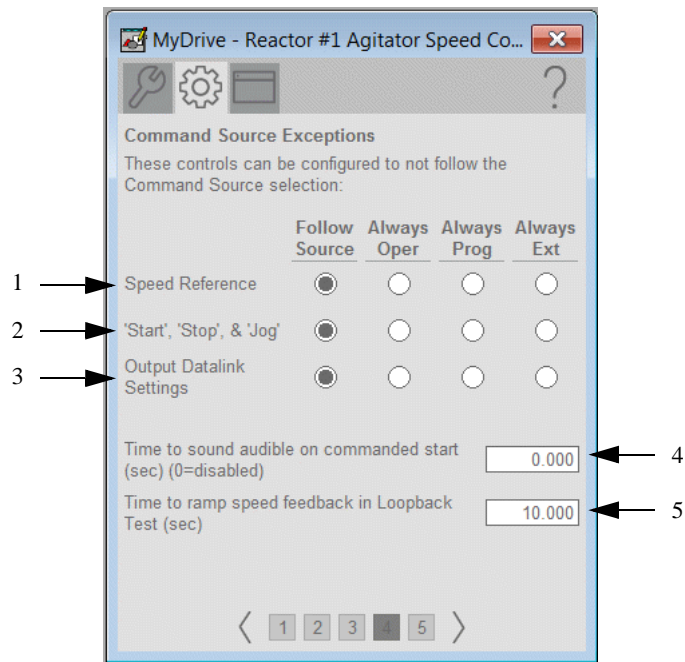
Item	Description
8	Check to have the interlocks and permissives that can be bypassed, bypassed in Override command source.
9	Check (= 1) so that the OCmd_Stop has priority and is accepted at any time. If the Command Source is not Operator or Maintenance, the motor or drive requires a reset. Clear this checkbox (= 0) so that the OCmd_Stop works only in Operator or Maintenance command source.
10	Check (= 1) so that the XCmd_Stop has priority and is accepted at any time. If the Command Source is not External, the motor or drive requires a reset. Clear this checkbox (= 0) so that the XCmd_Stop only works when the command source is External.



**Table 209 - Engineering Tab Page 3 Description**

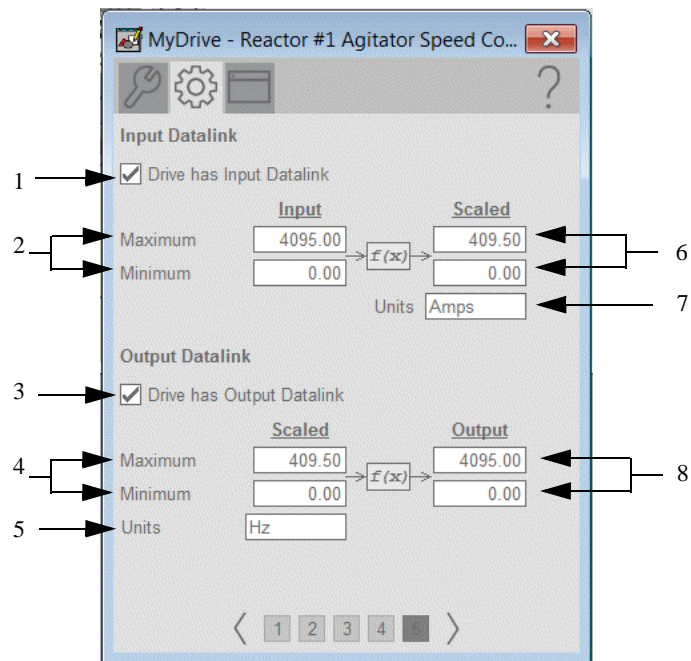
Item	Description
1	Check to allow for local command source start and stop without triggering a fault.
2	Check to have Program settings, such as Speed Reference, track Operator settings in Operator command source, and have Operator settings track Program settings in Program command source.
3	Check to have Program and Operator Speed Reference track the Override Speed Reference in Override command source or the actual speed in Hand command source.

Item	Description
4	Check to stop the drive if an I/O Fault is detected. Clear this checkbox show the I/O Fault Status/Alarm only and not stop the drive if an I/O Fault is detected.
5	When the bit is <b>on</b> and a motor Fail to Start is detected, the drive is stopped. A reset is required before another start can be attempted. If the bit is <b>off</b> and a drive Fail to Start is detected, the instruction sets only the Sts_FailToStart status (and the Alm_FailToStart alarm, if so configured). The outputs are not changed, so the instruction continues to start the drive.
6	The drive always stops on an Interlock not OK. This item cannot be unchecked. It is displayed as a reminder that the Interlock not OK function always stops the drive.



**Table 210 - Engineering Tab Page 4 Description**

Item	Description
1	Check to keep control of the drive Speed Reference with the Operator, Program, External, or Follow the Source even if the instruction is in Program command source.
2	Check to keep control of the drive Start, Stop, and Jog commands with the Operator, Program, External, or Follow the Source, even if the instruction is in Operator command source. <b>IMPORTANT:</b> The Program cannot Jog the drive, even if Jogging is enabled.
3	Check to keep control of the Output Datalink Setting (if used) with the Operator, Program, External, or Follow the Source even if the instruction is in Program command source.
4	Type the time (in seconds) the audible alarm sounds on a commanded start.
5	Enter the time, in seconds, to ramp speed feedback when in Simulation.

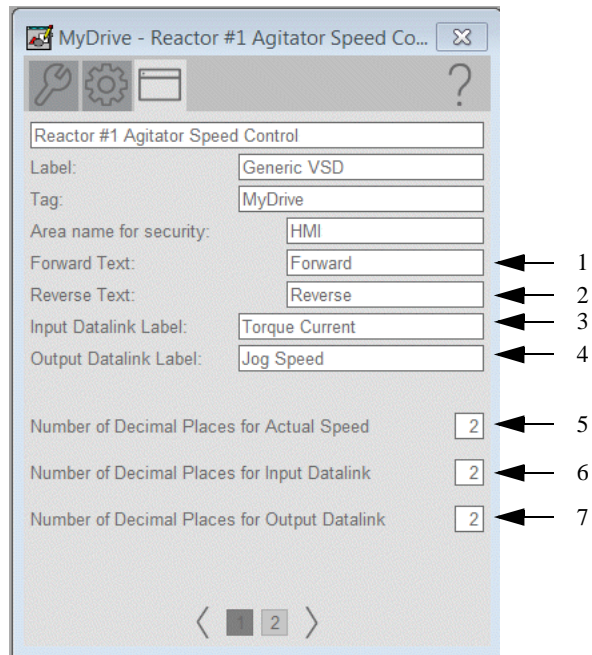


### Engineering Tab Page 5 Description

Item	Description
1	Check if Inp_Datalink is used. This check makes the Input Datalink configuration and operation functions visible.
2	Configure the minimum and maximum raw (from the drive) units for the Input Datalink.
3	Check if Out_Datalink is used. This check makes the Output Datalink configuration and operation functions visible.
4	Configure the minimum and maximum scaled values for the Output Datalink in Engineering Units.
5	Enter the text to display the units of measure for the Output Datalink.
6	Configure the minimum and maximum scaled values for the Input Datalink in Engineering Units.
7	Type the text to display the units of measure for the Input Datalink.
8	Configure the minimum and maximum scaled values for the Output Datalink in Raw (to the drive) Units. Enter the text to display for the label and units of measure of the Output Datalink.

### HMI Configuration Tab

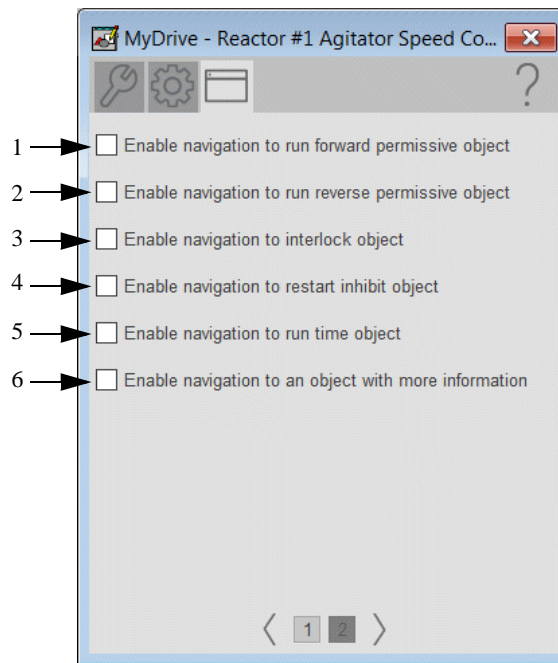
The HMI configuration tab provides access to displayed text, and faceplate-to-faceplate navigation settings. Configure the description, label, tag, and security area for the device. See [Basic Faceplate Attributes on page 32](#) for the description of the common attributes.



**Table 211 - HMI Configuration Page 1 Description**

Item	Description
1	Type a name for forward direction.
2	Type a name for reverse direction.
3	Type the text to display for the label of the Input Datalink.
4	Type the text to display for the label of the Output Datalink.
5	Type the number of decimal places to be shown for actual speed.
6	Type the number of decimal places to be shown for input datalink.
7	Type the number of decimal places to be shown for output datalink.





**Table 212 - HMI Configuration Page 2 Description**

Item	Description
1	Check if a permissive object is connected to Inp_FwdPermOK. The Permissive indicator becomes a button that opens the permissive faceplate. <b>IMPORTANT:</b> The name of the Forward Permissive object in the controller must be the name of the object with the suffix '_FwdPerm'. For example, if your P_PF52x object has the name 'Drive123', then its Forward Permissive object must be named 'Drive123_FwdPerm'.
2	Check if a permissive object is connected to Inp_RevPermOK. The Permissive indicator becomes a button that opens the permissive faceplate. <b>IMPORTANT:</b> The name of the Reverse Permissive object in the controller must be the name of the object with the suffix '_RevPerm'. For example, if your P_PF52x object has the name 'Drive123', then its Reverse Permissive object must be named 'Drive123_RevPerm'.
3	Check if an interlock object is connected to Inp_IntlkOK. The Interlock indicator becomes a button that opens the interlock faceplate. <b>IMPORTANT:</b> The name of the Interlock object in the controller must be the name of the object with the suffix '_Intlk'. For example, if your P_PF52x object has the name 'Drive123', then its Interlock object must be named 'Drive123_Intlk'.

Item	Description
4	<p>Check if a restart inhibit object is connected. The button that opens the Restart Inhibit faceplate appears.</p> <p><b>IMPORTANT:</b> The name of the Restart Inhibit object in the controller must be the name of the object with the suffix ‘_ResInh’. For example, if your P_PF52x object has the name ‘Drive123’, then its Restart Inhibit object must be named ‘Drive123_ResInh’.</p>
5	<p>Check if a runtime object is connected. The button that opens the runtime faceplate appears.</p> <p><b>IMPORTANT:</b> The name of the runtime object in the controller must be the name of the object with the suffix ‘_RunTime’. For example, if your P_PF52x object has the name ‘Drive123’, then its runtime object must be named ‘Drive123_RunTime’.</p>
6	<p>Check to enable navigation to an object with more information (Cfg_HasMoreObj is set to true.)</p> <p>This can be configured to navigate to an AOI backing tag or a UDT tag that has HMI_Type and HMI_Lib defined.</p> <p>For example, there is a motor with the tag name P_101 and there is a need to have the more information button navigate to the parent P_LLS object. A tag is created for the P_LLS object that is given the alias P101_More. When the more information button is pressed on the motor, it links to P101_More. This will open the faceplate for the LLS object.</p>

## Diagnostics Tab

The Diagnostic tab provides indications that are helpful to diagnose or help prevent device problems. The device problems can include specific reasons a device is 'Not Ready', device warnings and faults, warning and fault history, and predictive/preventive maintenance data.

The Diagnostics tab displays possible reasons for the device not being ready. See [Diagnostics Tab on page 36](#)

## Alarms Tab

The Alarms tab displays each configured alarm. The icon on the tab for the alarms page changes color to show the current active alarm status. A blinking alarm icon indicates that one or more alarms must be acknowledged or the device must be reset. See [Common Alarm Block \(P\\_Alarm\) on page 66](#) for more information.

## **PowerFlex 523/525 Variable Frequency Drives (P\_PF52x)**

The P\_PF52x (PowerFlex® 523/525 Variable Frequency Drives) object is used to control and monitor a PowerFlex 523 variable-frequency drive with optional EtherNet/IP Interface. The P\_PF52x can also control and monitor a PowerFlex 525 variable-frequency drive with embedded or optional add-on EtherNet/IP Interface.

This document is for the visualization files, display elements, global objects, and HMI information. The operation of the Add-on Instructions and controller code is contained in publication [PROCES-RM013](#).

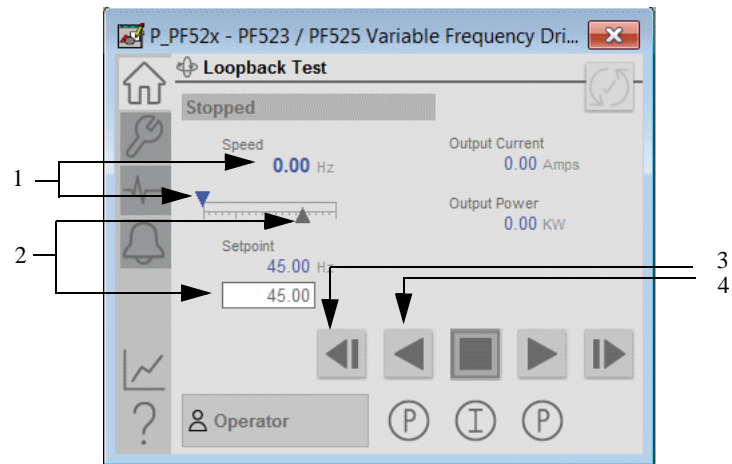
### **Display Elements (P\_PF52x)**

A display element (global object) is created once and can be referenced multiple times on multiple displays in an application. When changes are made to the original (base) object, the instantiated copies (reference objects) are automatically updated. Use of global objects, with tag structures in the ControlLogix system, aid consistency and save engineering time.

The P\_PF52x instruction uses the same HMI display elements that are used for the Variable Speed Drive (P\_VSD) instruction. See [Display Elements \(P\\_VSD\) on page 299](#)

## Operator Tab

The Faceplate initially opens to the Operator (Home) tab. From here, an operator can monitor the device status and manually operate the device when it is in Operator command source. Several features are common to all Add-On Instructions faceplates for the motors family. See [Common Operator Tab - Motors on page 247](#).



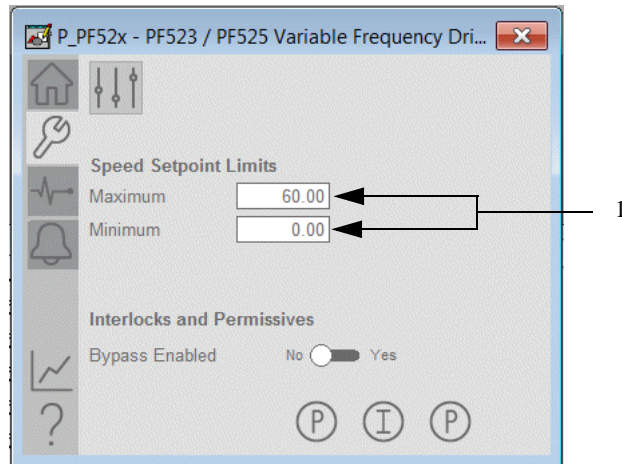
**Table 213 - Operator Tab Description**

Item	Description
1	Current speed of drive.
2	Setpoint for the speed of the drive.
3	Jog drive in reverse.
4	start drive in reverse.

## Maintenance Tab

Maintenance personnel use the information and controls on the Maintenance tab to adjust device parameters, troubleshoot, temporarily work around device problems, and disable the device for routine maintenance. Several features are common to all Add-On Instructions faceplates for the motors family.

See [Common Maintenance Tab - Motors on page 248](#)



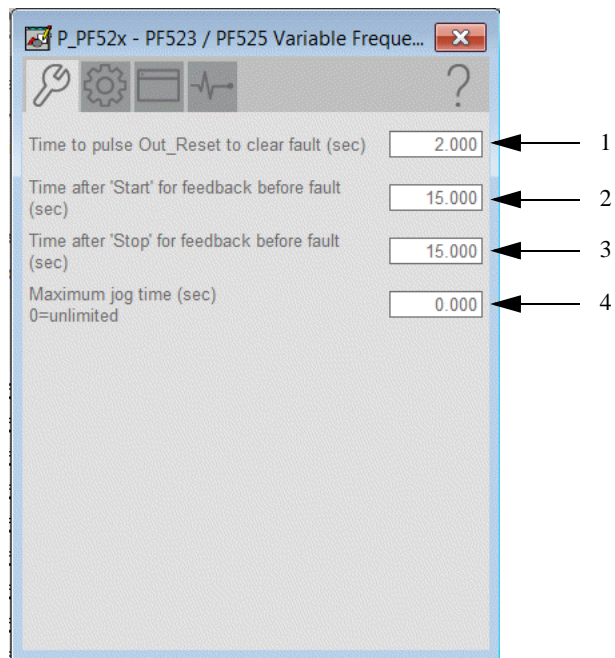
**Table 214 - Maintenance Tab Description**

Item	Description
1	Type the clamping limits for the speed setpoint. If a speed setpoint outside this range is entered, the speed is clamped at these limits and Sts_SpeedLimited is asserted.

## Advanced Properties Display

The Advanced Properties Display opens to the advanced maintenance settings. The Advanced Properties Display provides access to device configuration parameters and ranges, and options for device and I/O setup. This tab is used for initial system commissioning or later system changes.

### Advanced Maintenance Tab

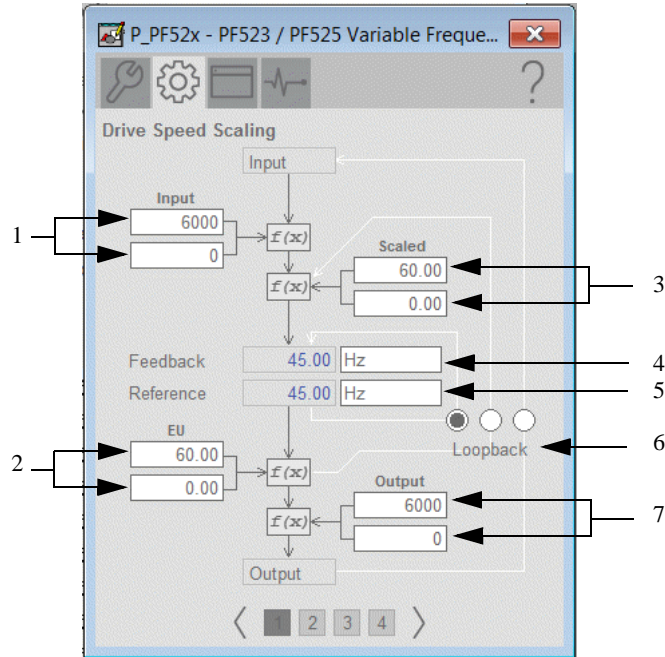


**Table 215 - Advanced Maintenance Tab Description**

Item	Description
1	Type the amount of time to hold Out_Reset true to reset a drive fault when a reset command is received.
2	Type the amount of time for the run feedback of the drive to confirm that the drive has started before raising a Fail to Start alarm.
3	Type the amount of time for the run feedback of the drive to confirm that the drive has stopped before raising a Fail to Stop alarm.
4	Type the maximum amount of time allowed to jog the motor.

### Engineering Tab

The Engineering tab has four pages.

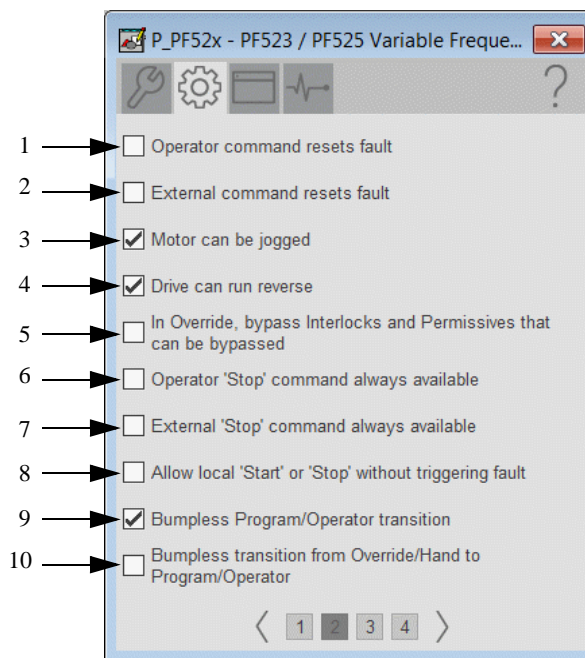


**Table 216 - Engineering Tab Page 1 Description**

Item	Description
1	Type the raw input count that corresponds to the maximum and minimum (This value is typically zero.) speed feedback from the drive
2	Type the engineering unit value for the maximum and minimum (typically zero) speed reference sent to the drive. Do not enter a negative value for reversing drives. Reversing is handled separately.
3	Type the engineering unit value for the maximum and minimum (typically zero) speed feedback from the drive. Do not enter a negative value for reversing drives. Reversing is handled separately.
4	Type the text of the units of measure of the scaled speed feedback. (typically Hz, RPM, or Percent.)



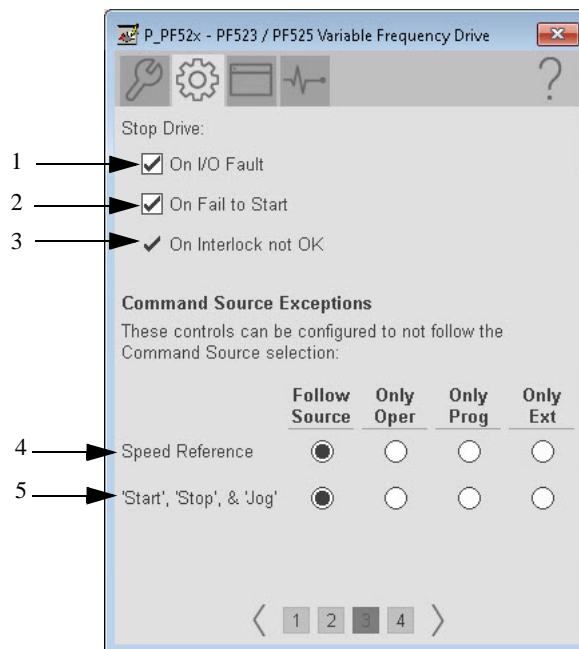
Item	Description
5	Type the text of the units of measure of the scaled speed reference. (typically Hz, RPM, or Percent.)
6	<p>Click the Simulation option (left, middle, or right) that corresponds to how the speed feedback for the drive is to be determined from the speed reference when the drive is being simulated (Inp_Sim = 1).</p> <p>Click the left option to copy the speed reference in engineering units to the speed feedback. (The simulated feedback is ramped to act like a drive that is accelerating or decelerating.) Use this option if the speed reference and speed feedback use the same scaling parameters</p> <p>Click the middle option to scale the simulated feedback from the speed-reference engineering unit range to the speed-feedback engineering unit range. Use this setting if the speed reference and speed feedback have different engineering ranges. For example, percent for reference and Hz for feedback), but the maximum reference (for example, 100%) corresponds to the maximum feedback (for example, 3600 RPM.</p> <p>Click the right option to scale the speed reference to raw units, copy the speed reference in raw units to speed feedback raw units, and scale to speed feedback engineering units. Use this setting if the reference and feedback ranges do not correspond.</p>
7	Type the raw output count that corresponds to the maximum and minimum (This value is typically zero.) speed reference sent to the drive.



**Table 217 - Engineering Tab Page 2 Description**

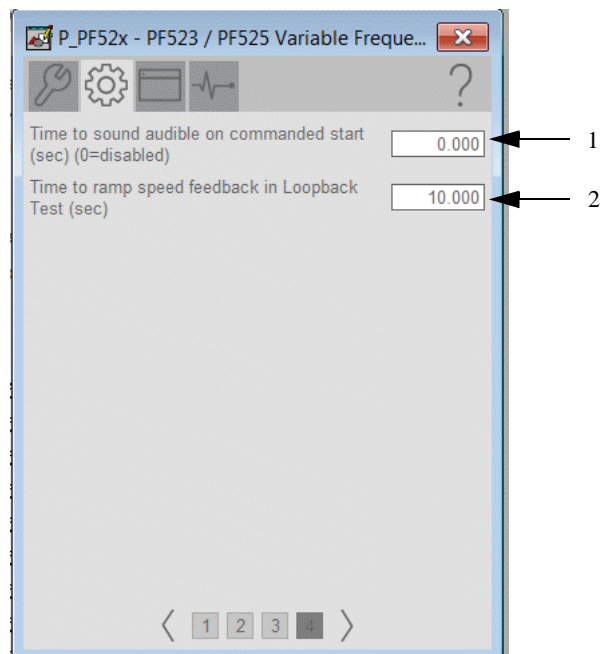
Item	Description
1	Check to reset faults on a new Operator command. Clear this checkbox if a reset is required to clear faults.
2	Check to reset faults on a new External command. Clear this checkbox if a reset is required to clear faults.
3	Check to make the Jog command button visible on the Operator tab and enable the drive to be jogged from the faceplate.
4	Check to make the forward and reverse direction command buttons visible on the Operator tab and enable the drive to run forward or reverse.

Item	Description
5	Check to have the interlocks and permissives that can be bypassed, bypassed in Override command source.
6	Check (= 1) so that the OCmd_Stop has priority and is accepted at any time. If the Command Source is not Operator or Maintenance, the motor or drive requires a reset. Clear this checkbox (= 0) so that the OCmd_Stop works only in Operator or Maintenance command source.
7	Check (= 1) so that the XCmd_Stop has priority and is accepted at any time. If the Command Source is not External, the motor or drive requires a reset. Clear this checkbox (= 0) so that the XCmd_Stop only works when the command source is External.
8	Check (= 1) to let local circuits start/stop the drive without an alarm. Clear this checkbox (= 0) to start/stop the drive from the HMI or program only.
9	Check to have program settings, such as Speed Reference, track operator settings in Operator command source, and have operator settings track Program Settings in Program command source.
10	Check to have the Program and Operator Speed Reference track the Override Speed Reference in Override command source or the actual speed in Hand command source.



**Table 218 - Engineering Tab Page 3 Description**

Item	Description
1	Check to stop the drive if an I/O Fault is detected. After the I/O Fault clears, a reset is required before the drive can be started. Clear this checkbox to show only the I/O Fault Status/Alarm and not stop the drive if an I/O Fault is detected.
2	Check to stop the drive on a failure to start. A reset is required before another start can be attempted. Clear this checkbox to show only the Fail to Start status and alarm on a failure to start. The outputs are not changed, so the instruction continues to attempt to start the motor.
3	The drive always stops on an Interlock not OK. This item cannot be cleared. It is displayed as a reminder that the Interlock not OK function always stops the drive.
4	Check to keep control of the drive Speed Reference with the Operator, Program, External, or Follow the Source even if the instruction is in Program command source. Clear this checkbox to have control of the drive Speed Reference follow the Instruction command source.
5	Check to keep control of the drive Start and Stop commands with the Operator, Program, External, or Follow the Source, even if the instruction is in Operator command source. <b>IMPORTANT:</b> The Program cannot Jog the drive, even if Jogging is enabled. Clear this checkbox to have control of the drive Start, Stop, and Jog follow Instruction command source.

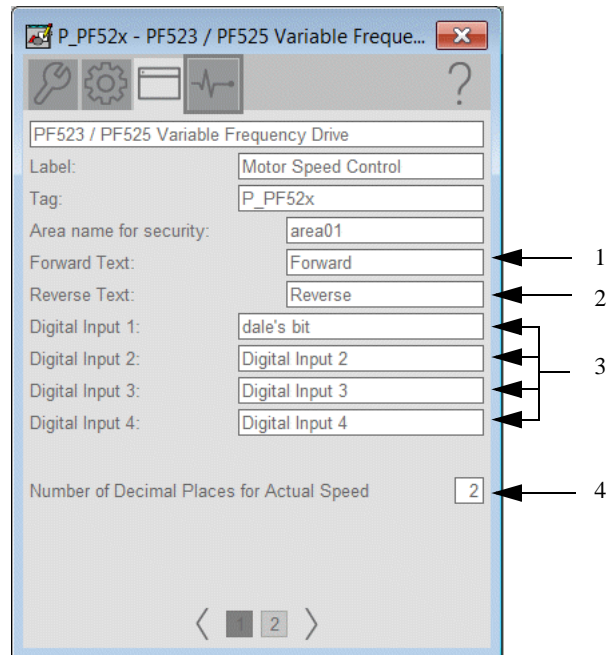
**Table 219 - Engineering Tab Page 4 Description**

Item	Description
1	Type the time (in seconds) the audible alarm sounds on a commanded start.
2	Type the time, in seconds, to ramp speed feedback when in Simulation.

### HMI Configuration Tab

The HMI configuration tab provides access to displayed text, and faceplate-to-faceplate navigation settings. Configure the description, label, tag, and security area for the device. See [Basic Faceplate Attributes on page 32](#) for the description of the common attributes.

The HMI configuration tab has two pages.



**Table 220 - HMI Configuration Tab Page 1 Description**

Item	Description
1	Type a name for forward direction.
2	Type a name for reverse direction.
3	Type names for the digital inputs.
4	Type the number of decimal places to be shown for actual speed.

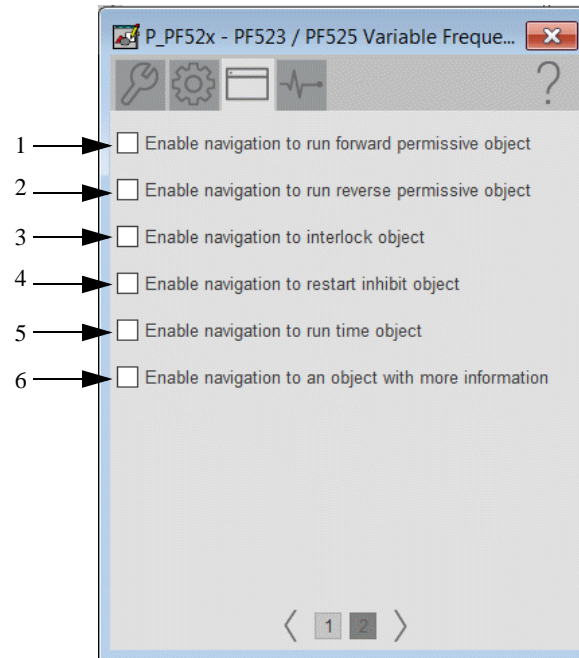


Table 221 - HMI Configuration Tab Page 2 Description

Item	Description
1	Check if a permissive object is connected to Inp_FwdPermOK. The Permissive indicator becomes a button that opens the permissive faceplate. <b>IMPORTANT:</b> The name of the Forward Permissive object in the controller must be the name of the object with the suffix '_FwdPerm'. For example, if your P_PF52x object has the name 'Drive123', then its Forward Permissive object must be named 'Drive123_FwdPerm'.
2	Check if a permissive object is connected to Inp_RevPermOK. The Permissive indicator becomes a button that opens the permissive faceplate. <b>IMPORTANT:</b> The name of the Reverse Permissive object in the controller must be the name of the object with the suffix '_RevPerm'. For example, if your P_PF52x object has the name 'Drive123', then its Reverse Permissive object must be named 'Drive123_RevPerm'.
3	Check if an interlock object is connected to Inp_IntlkOK. The Interlock indicator becomes a button that opens the interlock faceplate. <b>IMPORTANT:</b> The name of the Interlock object in the controller must be the name of the object with the suffix '_Intlk'. For example, if your P_PF52x object has the name 'Drive123', then its Interlock object must be named 'Drive123_Intlk'.

Item	Description
4	<p>Check if a restart inhibit object is connected. The button that opens the Restart Inhibit faceplate appears.</p> <p><b>IMPORTANT:</b> The name of the Restart Inhibit object in the controller must be the name of the object with the suffix ‘_ResInh’. For example, if your P_PF52x object has the name ‘Drive123’, then its Restart Inhibit object must be named ‘Drive123_ResInh’.</p>
5	<p>Check if a runtime object is connected. The button that opens the runtime faceplate appears.</p> <p><b>IMPORTANT:</b> The name of the runtime object in the controller must be the name of the object with the suffix ‘_RunTime’. For example, if your P_PF52x object has the name ‘Drive123’, then its runtime object must be named ‘Drive123_RunTime’.</p>
6	<p>Check to enable navigation to an object with more information (Cfg_HasMoreObj is set to true.)</p> <p>This can be configured to navigate to an AOI backing tag or a UDT tag that has HMI_Type and HMI_Lib defined.</p> <p>For example, there is a motor with the tag name P_101 and there is a need to have the more information button navigate to the parent P_LLS object. A tag is created for the P_LLS object that is given the alias P101_More. When the more information button is pressed on the motor, it links to P101_More. This will open the faceplate for the LLS object.</p>

## Trends Tab

The Trends tab shows trend charts of key device data over time. These faceplate trends provide a quick view of current device performance to supplement, but not replace, dedicated historical or live trend displays. The trends displays are common across all Motors Family Add-On Instructions. See [Common Trends Tab - Motors on page 249](#)

## Alarms Tab

The Alarms tab displays each configured alarm. The icon on the tab for the alarms page changes color to show the current active alarm status. A blinking alarm icon indicates that one or more alarms must be acknowledged or the device must be reset. See [Common Alarm Block \(P\\_Alarm\) on page 66](#) for more information.

## **PowerFlex 753 Drive (P\_PF753)**

The P\_PF753 (PowerFlex 753 Drive) object is used to operate one variable-speed motor by using a PowerFlex 753 AC variable frequency drive in various command sources, and monitoring for fault conditions.

This document is for the visualization files, display elements, global objects, and HMI information. The operation of the Add-on Instructions and controller code is contained in publication [PROCES-RM013](#).

### **Display Elements (P\_PF753)**

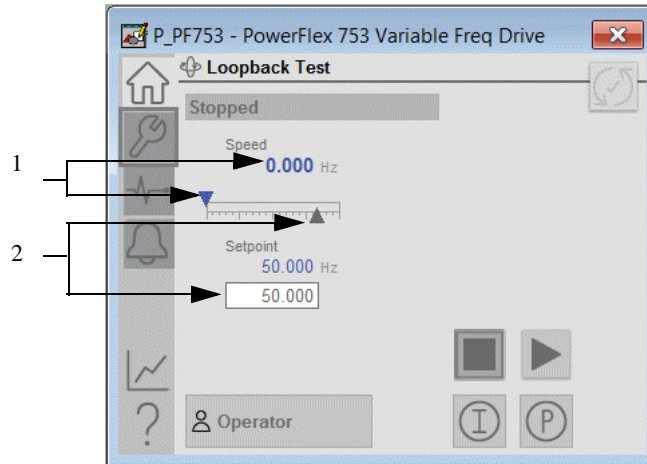
A display element (global object) is created once and can be referenced multiple times on multiple displays in an application. When changes are made to the original (base) object, the instantiated copies (reference objects) are automatically updated. Use of global objects, with tag structures in the ControlLogix system, aid consistency and save engineering time.

The P\_PF753 instruction uses the same HMI display elements that are used for the Variable Speed Drive (P\_VSD) instruction. See [Display Elements \(P\\_VSD\) on page 299](#)



## Operator Tab

The Faceplate initially opens to the Operator (Home) tab. From here, an operator can monitor the device status and manually operate the device when it is in Operator command source. Several features are common to all Add-On Instructions faceplates for the motors family. See [Common Operator Tab - Motors on page 247](#).



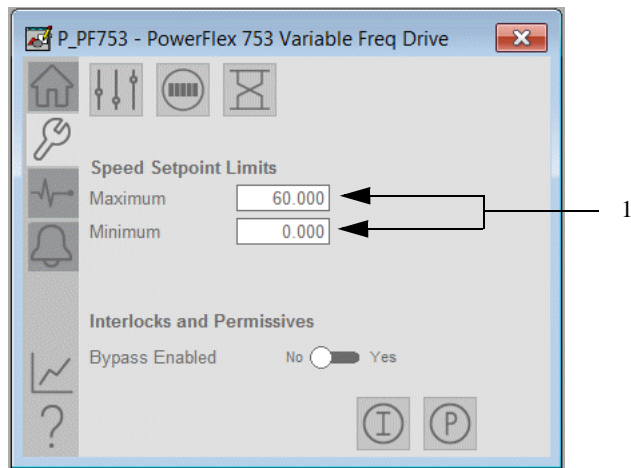
**Table 222 - Operator Tab Description**

Item	Description
1	Current speed of drive
2	Setpoint for the speed of the drive

## Maintenance Tab

Maintenance personnel use the information and controls on the Maintenance tab to adjust device parameters, troubleshoot, temporarily work around device problems, and disable the device for routine maintenance. Several features are common to all Add-On Instructions faceplates for the motors family.

See [Common Maintenance Tab - Motors on page 248](#)



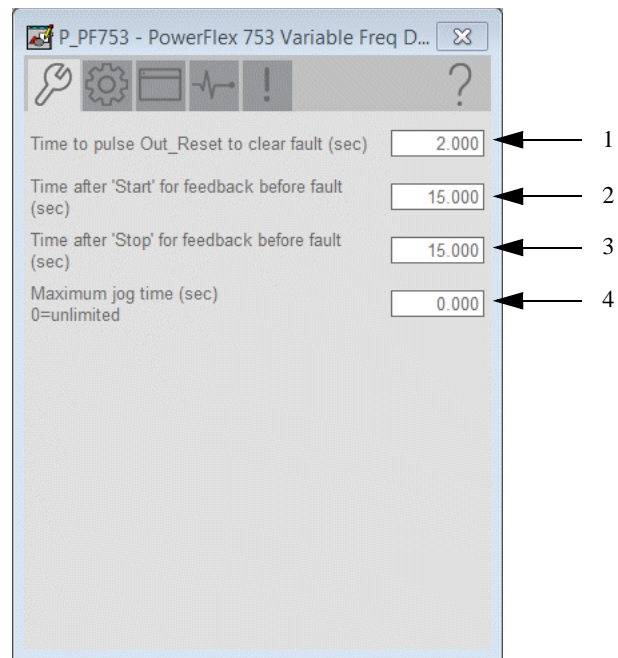
**Table 223 - Maintenance Tab Description**

Item	Description
1	Type the clamping limits for the speed setpoint. If a speed setpoint outside this range is entered, the speed is clamped at these limits and Sts_SpeedLimited is asserted.

## Advanced Properties Display

The Advanced Properties Display opens to the advanced maintenance settings. The Advanced Properties Display provides access to device configuration parameters and ranges, and options for device and I/O setup. This tab is used for initial system commissioning or later system changes.

### Advanced Maintenance Tab

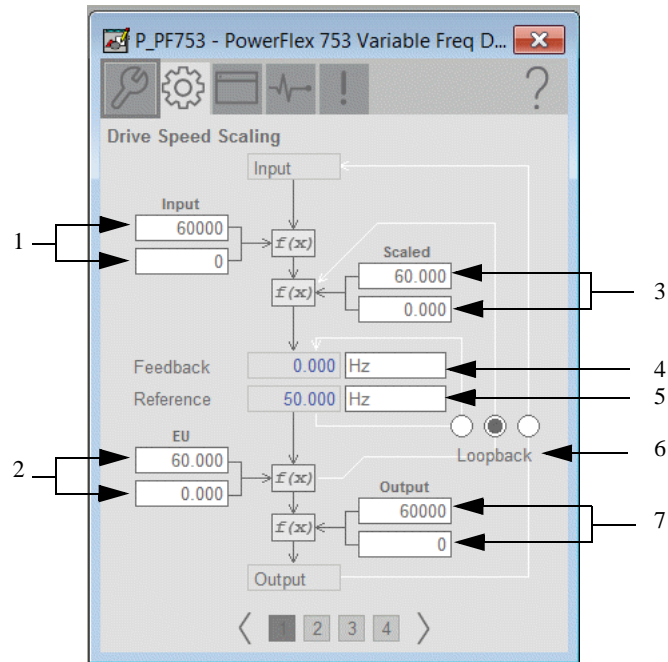


**Table 224 - Advanced Maintenance Tab Description**

Item	Description
1	Type the amount of time to hold Out_Reset true to reset a drive fault when a reset command is received.
2	Type the amount of time for the run feedback of the drive to confirm that the drive has started before raising a Fail to Start alarm.
3	Type the amount of time for the run feedback of the drive to confirm that the drive has stopped before raising a Fail to Stop alarm.
4	Type the maximum amount of time allowed to jog the motor.

### Engineering Tab

The engineering tab has four pages.



**Table 225 - Engineering Page 1 Description**

Item	Description
1	Type the raw input count that corresponds to the maximum and minimum (This value is usually zero.) speed feedback from the drive
2	Type the engineering unit value for the maximum and minimum (usually zero) speed reference sent to the drive. Do not enter a negative value for reversing drives. Reversing is handled separately.
3	Type the engineering unit value for the maximum and minimum (usually zero) speed feedback from the drive. Do not enter a negative value for reversing drives. Reversing is handled separately.
4	Type the text of the units of measure of the scaled speed feedback. (Often Hz, RPM, or Percent.)

Item	Description
5	Type the text of the units of measure of the scaled speed reference. (Often Hz, RPM, or Percent.)
6	<p>Click the Simulation option (left, middle, or right) that corresponds to how the speed feedback for the drive is to be determined from the speed reference when the drive is being simulated (Inp_Sim = 1).</p> <p>Click the left option to copy the speed reference in engineering units to the speed feedback. (The simulated feedback is ramped to act like a drive that is accelerating or decelerating.) Use this option if the speed reference and speed feedback use the same scaling parameters</p> <p>Click the middle option to scale the simulated feedback from the speed-reference engineering unit range to the speed-feedback engineering unit range. Use this setting if the speed reference and speed feedback have different engineering ranges. For example, percent for reference and Hz for feedback), but the maximum reference (for example, 100%) corresponds to the maximum feedback (for example, 3600 RPM.</p> <p>Click the right option to scale the speed reference to raw units, copy the speed reference in raw units to speed feedback raw units, and scale to speed feedback engineering units. Use this setting if the reference and feedback ranges do not correspond.</p>
7	Type the raw output count that corresponds to the maximum and minimum (This value is usually zero.) speed reference sent to the drive.

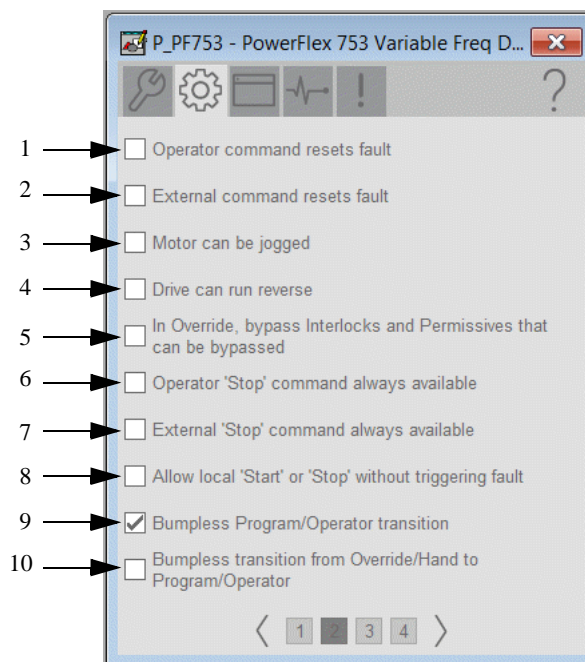


Table 226 - Engineering Page 2 Description

Item	Description
1	Check to reset faults on a new Operator command. Clear this checkbox if a reset is required to clear faults.
2	Check to reset faults on a new External command. Clear this checkbox if a reset is required to clear faults.
3	Check to make the Jog command button visible on the Operator tab and enable the drive to be jogged from the faceplate
4	Check to make the forward and reverse direction command buttons visible on the Operator tab and enable the drive to run forward or reverse.

Item	Description
5	Check to have the interlocks and permissives that can be bypassed, bypassed in Override command source.
6	Check (= 1) so that the OCmd_Stop has priority and is accepted at any time. If the Command Source is not Operator or Maintenance, the motor or drive requires a reset. Clear this checkbox (= 0) so that the OCmd_Stop works only in Operator or Maintenance command source.
7	Check (= 1) so that the XCmd_Stop has priority and is accepted at any time. If the Command Source is not External, the motor or drive requires a reset. Clear this checkbox (= 0) so that the XCmd_Stop only works when the command source is External.
8	Check (= 1) to let local circuits start/stop the drive without an alarm. Clear this checkbox (= 0) to start/stop the drive from the HMI or program only.
9	Check to have program settings, such as Speed Reference, track operator settings in Operator command source, and have operator settings track Program Settings in Program command source.
10	Check to have the Program and Operator Speed Reference track the Override Speed Reference in Override command source or the actual speed in Hand command source.

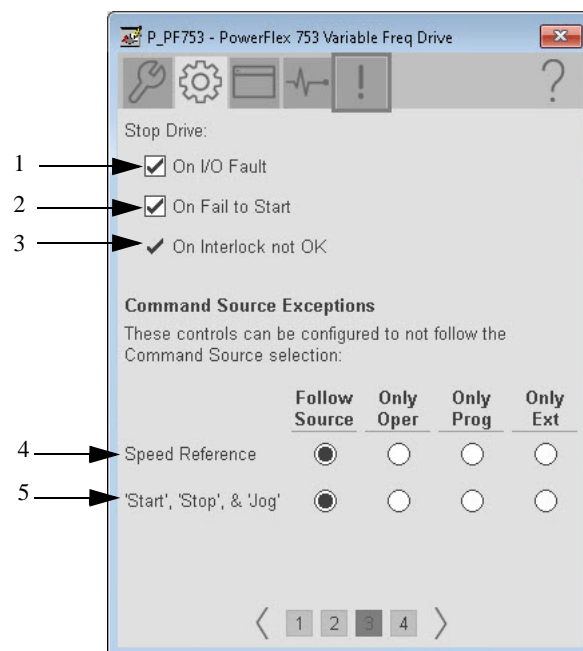
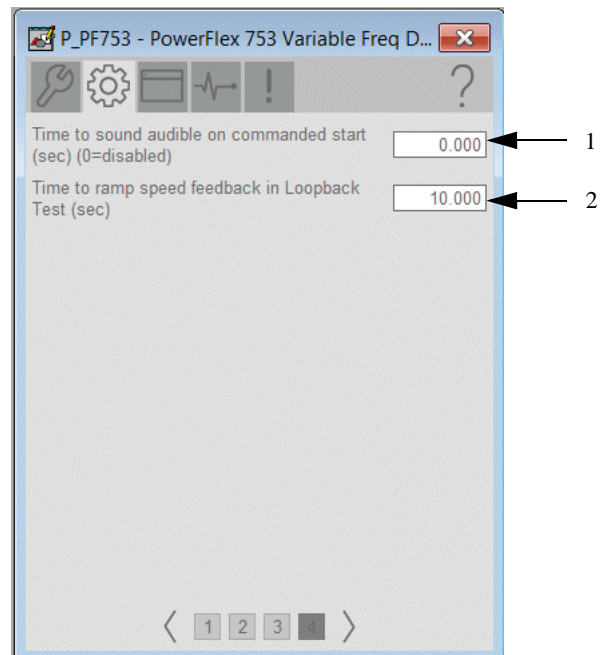


Table 227 - Engineering Page 3 Description

Item	Description
1	Check to stop the drive if an I/O Fault is detected. After the I/O Fault clears, a reset is required before the drive can be started. Clear this checkbox to show only the I/O Fault Status/Alarm and not stop the drive if an I/O Fault is detected.
2	Check to stop the drive on a failure to start. A reset is required before another start can be attempted. Clear this checkbox to show only the Fail to Start status and alarm on a failure to start. The outputs are not changed, so the instruction continues to attempt to start the motor.
3	The drive always stops on an Interlock not OK. This item cannot be cleared. It is displayed as a reminder that the Interlock not OK function always stops the drive.
4	Check to keep control of the drive Speed Reference with the Operator, Program, External, or Follow the Source even if the instruction is in Program command source. Clear this checkbox to have control of the drive Speed Reference follow the Instruction command source.
5	Check to keep control of the drive Start and Stop commands with the Operator, Program, External, or Follow the Source, even if the instruction is in Operator command source. <b>IMPORTANT:</b> The Program cannot Jog the drive, even if Jogging is enabled. Clear this checkbox to have control of the drive Start, Stop, and Jog follow Instruction command source.



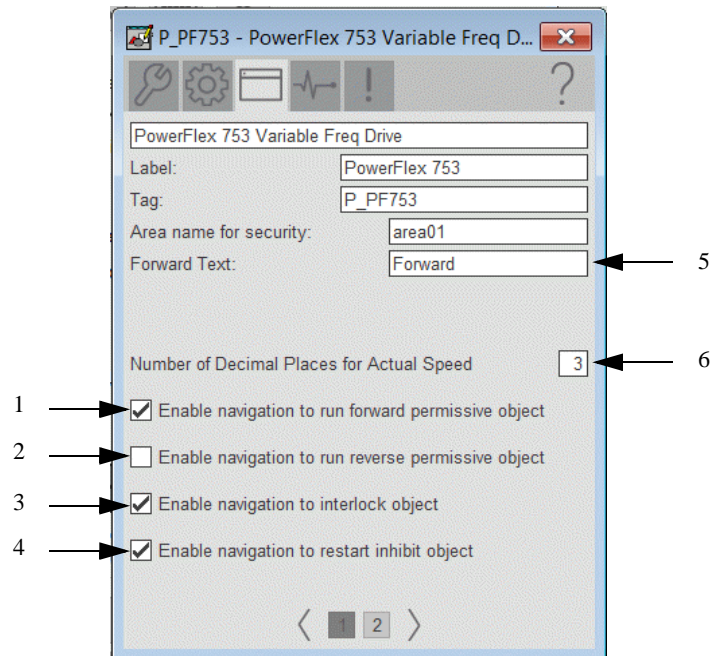
**Table 228 - Engineering Tab Page 4 Description**

<b>Item</b>	<b>Description</b>
1	Type the time (in seconds) the audible alarm sounds on a commanded start.
2	Type the time, in seconds, to ramp speed feedback when in Simulation.



## HMI Configuration Tab

The HMI configuration tab provides access to displayed text, and faceplate-to-faceplate navigation settings. Configure the description, label, tag, and security area for the device. See [Basic Faceplate Attributes on page 32](#) for the description of the common attributes.

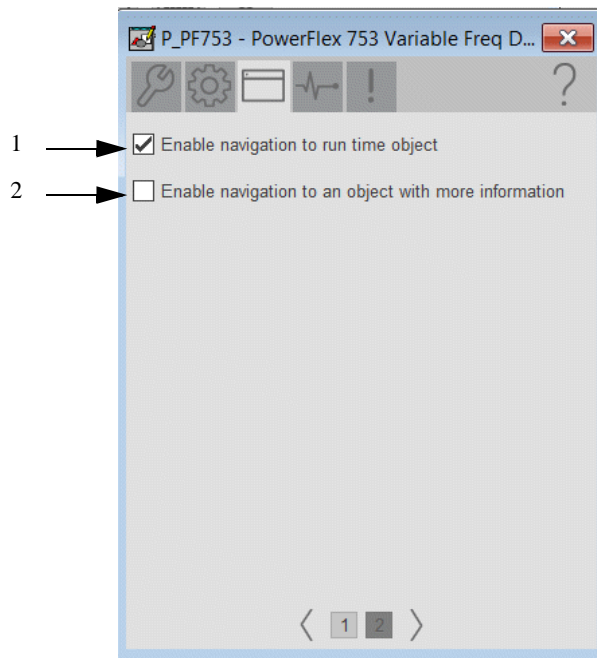


**Table 229 - HMI Configuration Page 1 Description**

Item	Description
1	Check if a permissive object is connected to Inp_FwdPermOK. The Permissive indicator becomes a button that opens the permissive faceplate. <b>IMPORTANT:</b> The name of the Forward Permissive object in the controller must be the name of the object with the suffix '_FwdPerm'. For example, if your P_PF52x object has the name 'Drive123', then its Forward Permissive object must be named 'Drive123_FwdPerm'.
2	Check if a permissive object is connected to Inp_RevPermOK. The Permissive indicator becomes a button that opens the permissive faceplate. <b>IMPORTANT:</b> The name of the Reverse Permissive object in the controller must be the name of the object with the suffix '_RevPerm'. For example, if your P_PF52x object has the name 'Drive123', then its Reverse Permissive object must be named 'Drive123_RevPerm'.
3	Check if an Interlock object is used with this motor. This check changes the Interlock indicator to a clickable button to open the Interlock faceplate. <b>IMPORTANT:</b> The name of the Interlock object in the controller must be the name of the object with the suffix '_Intlk'. For example, if your P_Motor object has the name 'Motor123', then its Interlock object must be named 'Motor123_Intlk'.

**Table 229 - HMI Configuration Page 1 Description**

Item	Description
4	Check if a Restart Inhibit object is used with this motor. This check makes the Restart Inhibit button visible. <b>IMPORTANT:</b> The name of the Restart Inhibit object in the controller must be the name of the object with the suffix ‘_ResInh’. For example, if your P_Motor object has the name ‘Motor123’, then its Restart Inhibit object must be named ‘Motor123_ResInh’.
5	Type the text to display when the motor is running forward.
6	Type the number of decimal places to be shown for actual speed.



**Table 230 - HMI Configuration Page 2 Description**

Item	Description
1	Check if a Run Time object is used with this motor. This check makes the Run Time button visible. <b>IMPORTANT:</b> The name of the Run Time object in the controller must be the name of the object with the suffix ‘_RunTime’. For example, if your P_Motor object has the name ‘Motor123’, then its Run Time object must be named ‘Motor123_RunTime’.
2	Check to enable navigation to an object with more information (Cfg_HasMoreObj is set to true.) This can be configured to navigate to an AOI backing tag or a UDT tag that has HMI_Type and HMI_Lib defined. For example, there is a motor with the tag name P_101 and there is a need to have the more information button navigate to the parent P_LLS object. A tag is created for the P_LLS object that is given the alias P101_More. When the more information button is pressed on the motor, it links to P101_More. This will open the faceplate for the LLS object.

## Diagnostics Tab

The Diagnostic tab provides indications that are helpful to diagnose or help prevent device problems. The device problems can include specific reasons a device is 'Not Ready', device warnings and faults, warning and fault history, and predictive/preventive maintenance data.

The Diagnostics tab displays possible reasons for the device not being ready. See [Diagnostics Tab on page 36](#)

## Alarms Tab

The Alarms tab displays each configured alarm. The icon on the tab for the alarms page changes color to show the current active alarm status. A blinking alarm icon indicates that one or more alarms must be acknowledged or the device must be reset. See [Common Alarm Block \(P\\_Alarm\) on page 66](#) for more information.

## Trends Tab

The Trends tab shows trend charts of key device data over time. These faceplate trends provide a quick view of current device performance to supplement, but not replace, dedicated historical or live trend displays. The trends displays are common across all Motors Family Add-On Instructions. See [Common Trends Tab - Motors on page 249](#)

## PowerFlex 755 Drive (P\_PF755)

The P\_PF755 (PowerFlex 755 drive) object is used to operate one variable-speed motor by using a PowerFlex 755 AC variable frequency drive in various command sources and monitoring for fault conditions.

This document is for the visualization files, display elements, global objects, and HMI information. The operation of the Add-on Instructions and controller code is contained in publication [PROCES-RM013](#).

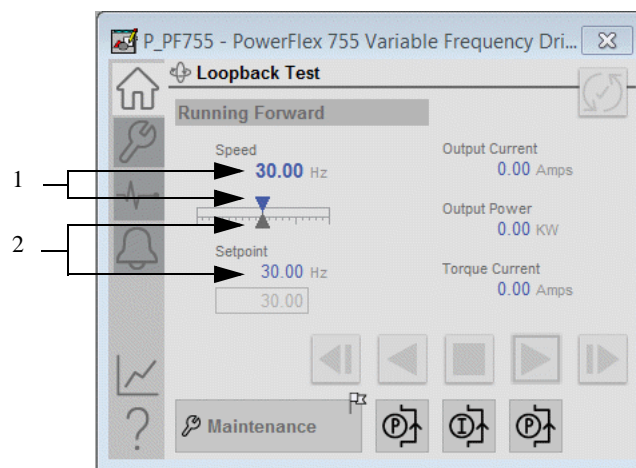
### Display Elements (P\_PF755)

A display element (global object) is created once and can be referenced multiple times on multiple displays in an application. When changes are made to the original (base) object, the instantiated copies (reference objects) are automatically updated. Use of global objects, with tag structures in the ControlLogix system, aid consistency and save engineering time.

The P\_PF753 instruction uses the same HMI display elements that are used for the Variable Speed Drive (P\_VSD) instruction. See [Display Elements \(P\\_VSD\) on page 299](#)

### Operator Tab

The Faceplate initially opens to the Operator (Home) tab. From here, an operator can monitor the device status and manually operate the device when it is in Operator command source. Several features are common to all Add-On Instructions faceplates for the motors family. See [Common Operator Tab - Motors on page 247](#).



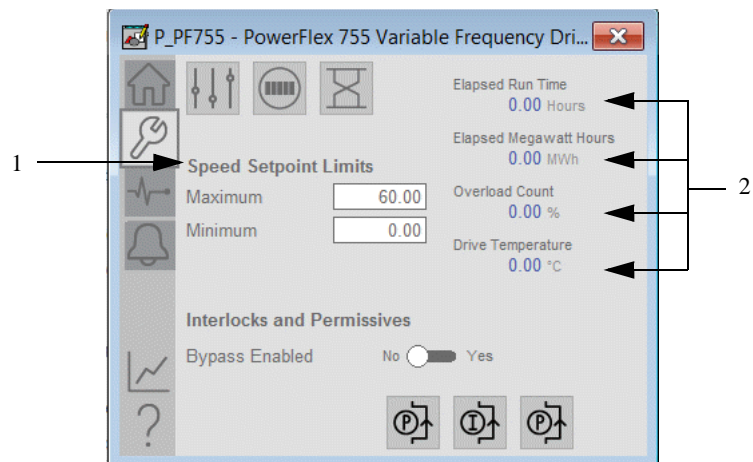
**Table 231 - Operator Tab Description**

Item	Description
1	Current speed of drive
2	Setpoint for the speed of the drive

## Maintenance Tab

Maintenance personnel use the information and controls on the Maintenance tab to adjust device parameters, troubleshoot, temporarily work around device problems, and disable the device for routine maintenance. Several features are common to all Add-On Instructions faceplates for the motors family.

See [Common Maintenance Tab - Motors on page 248](#)

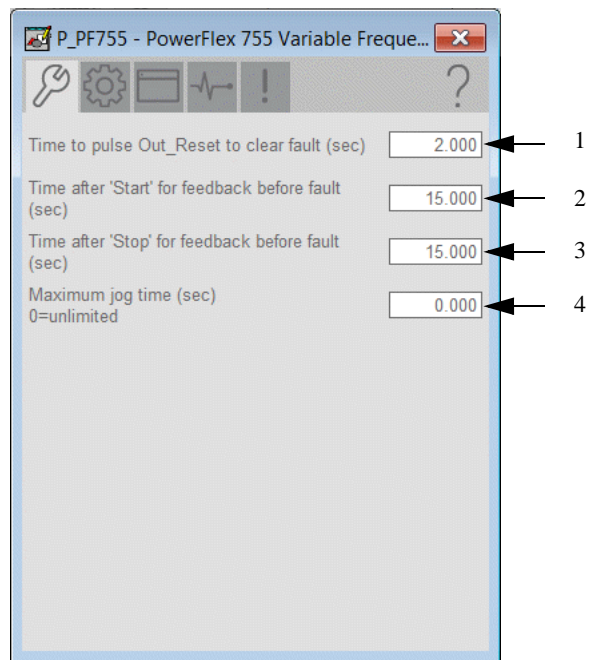
**Table 232 - Maintenance Tab Description**

Item	Description
1	Type the clamping limits for the speed setpoint. If a speed setpoint outside this range is entered, the speed is clamped at these limits and Sts_SpeedLimited is asserted.
2	Drive maintenance data.

## Advanced Properties Display

The Advanced Properties Display opens to the advanced maintenance settings. The Advanced Properties Display provides access to device configuration parameters and ranges, and options for device and I/O setup. This tab is used for initial system commissioning or later system changes.

### Advanced Maintenance Tab

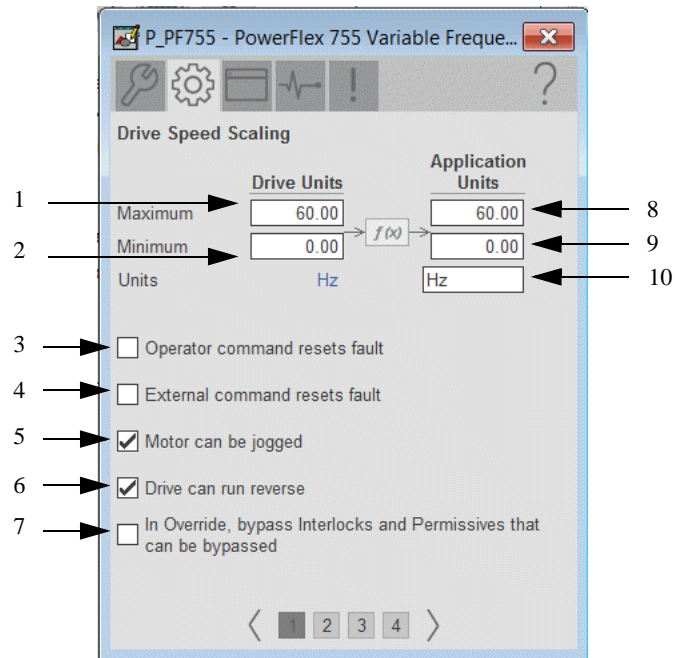


**Table 233 - Advanced Maintenance Tab Description**

Item	Description
1	Type the amount of time to hold Out_Reset true to reset a drive fault when a reset command is received.
2	Type the amount of time to allow for the run feedback of the drive to confirm that the drive has started before raising a Fail to Start alarm.
3	Type the amount of time to allow for the run feedback of the drive to confirm that the drive has stopped before raising a Fail to Stop alarm.
4	Type the maximum time (in seconds) that the drive can be jogged by using OCmd_Jog.  <b>IMPORTANT:</b> This value stops drive jogging if HMI communication is lost during a jog.

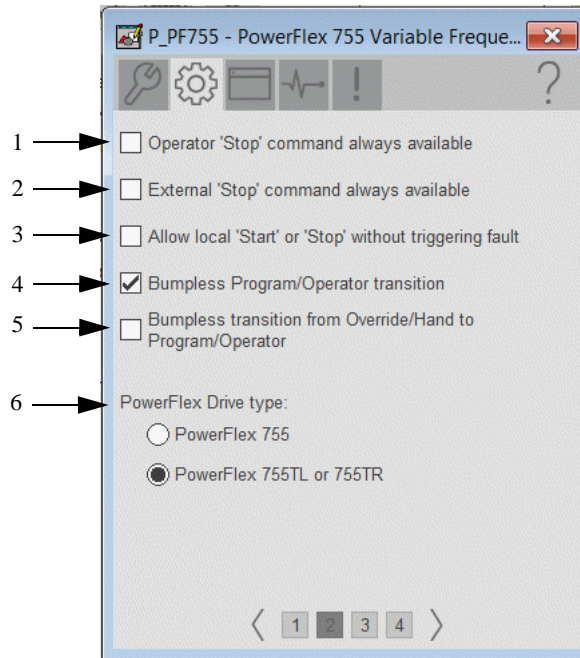
## Engineering Tab

The Engineering Tab consists of four pages.



**Table 234 - Engineering Tab Page 1 Description**

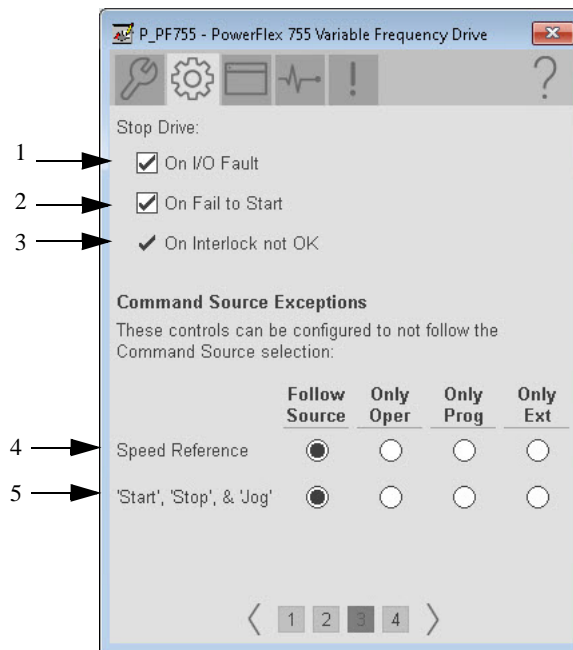
Item	Description
1	Type the engineering unit value for the maximum speed feedback from the drive.
2	Type the engineering unit value for the minimum speed feedback from the drive. (This value is usually zero. Do not enter a negative value for reversing drives. Reversing is handled separately.)
3	Check to permit the Operator Start or Stop command to reset any previous faults (I/O Fault, Fail to Start, Fail to Stop, Interlock Trip), then start or stop the motor. Clear this checkbox if a reset is required to clear faults.
4	Check to permit the External Start or Stop command to reset any previous faults (I/O Fault, Fail to Start, Fail to Stop, Interlock Trip), then start or stop the motor. Clear this checkbox if a reset is required to clear faults.
5	Check to enable Jog on the Operator tab so that the drive can be jogged from the faceplate.
6	Check to enable Forward and Reverse directions on the Operator tab so that the drive can be commanded to run forward or reverse.
7	Check to have the bypassable interlocks and permissives bypassed in Override command source.
8	Type the engineering unit value for the maximum speed reference sent to the drive.
9	Type the engineering unit value for the minimum speed reference sent to the drive. (This value is usually zero. Do not enter a negative value for reversing drives. Reversing is handled separately.)
10	Type the text of the units of measure Engineering Units of the scaled speed feedback. (Units of measure are often 'Hz', 'RPM' or 'Percent'.)



**Table 235 - Engineering Tab Page 2 Description**

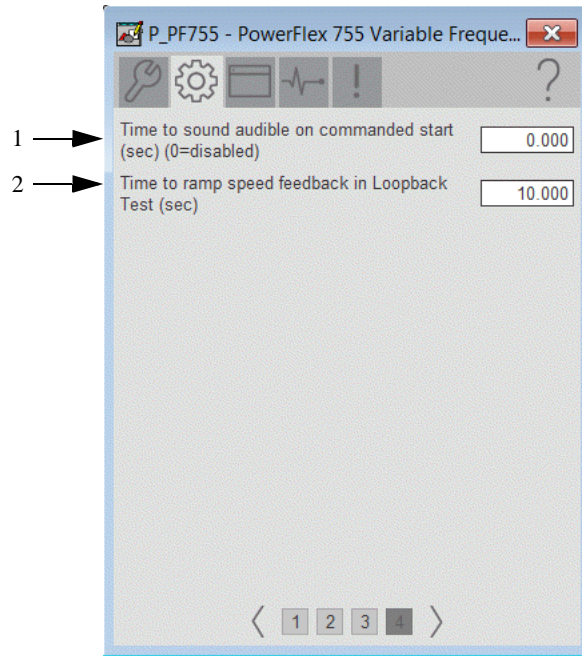
Item	Description
1	Check (= 1) so that the OCmd_Stop has priority and is accepted at any time. Clear this checkbox (= 0) so that the OCmd_Stop works only in Operator or Maintenance command source.
2	Check (= 1) so that the XCmd_Stop has priority and is accepted at any time. If the Command Source is not External, the motor or drive requires a reset. Clear this checkbox (= 0) so that the XCmd_Stop only works when the command source is External.
3	Check (= 1) to allow local start/stop without an alarm. Clear this checkbox (= 0) to start/stop from the HMI or program only.
4	Check to have program settings, such as Speed Reference, track operator settings in Operator command source, and have operator settings track Program Settings in Program command source.
5	Check to have the Program and Operator Speed Reference track the Override Speed Reference in Override command source or the actual speed in Hand command source.
6	Select the PowerFlex Drive type.





**Table 236 - Engineering Tab Page 3 Description**

Item	Description
1	Check to stop the drive if an I/O Fault is detected. Clear the checkbox to show only the I/O Fault Status/Alarm and not stop the drive if an I/O Fault is detected.
2	Check so that if a motor fail to start is detected, the motor is stopped. A reset is required before another start can be attempted.  Clear the checkbox and if a motor fail to start is detected, the instruction sets only the Sts_FailToStart status (and the Alm_FailToStart alarm, if so configured). The outputs are not changed, so the instruction continues to start the motor.
3	The motor always stops on an interlock not OK. This item cannot be unchecked. It is displayed as a reminder that the Interlock not OK function always trips the motor.
4	Check to keep control of the drive Speed Reference with the Operator, Program, External, or Follow the Source even if the instruction is in Program command source.
5	Check to keep control of the drive Start, Stop, and Jog commands with the Operator, Program, External, or Follow the Source, even if the instruction is in Operator command source. <b>IMPORTANT:</b> The Program cannot Jog the drive, even if Jogging is enabled.



**Table 237 - Engineering Tab Page 4 Description**

Item	Description
1	Type the time (in seconds) the audible alarm sounds on a commanded start.
2	Enter the time, in seconds, to ramp speed feedback when in Simulation.

## HMI Configuration Tab

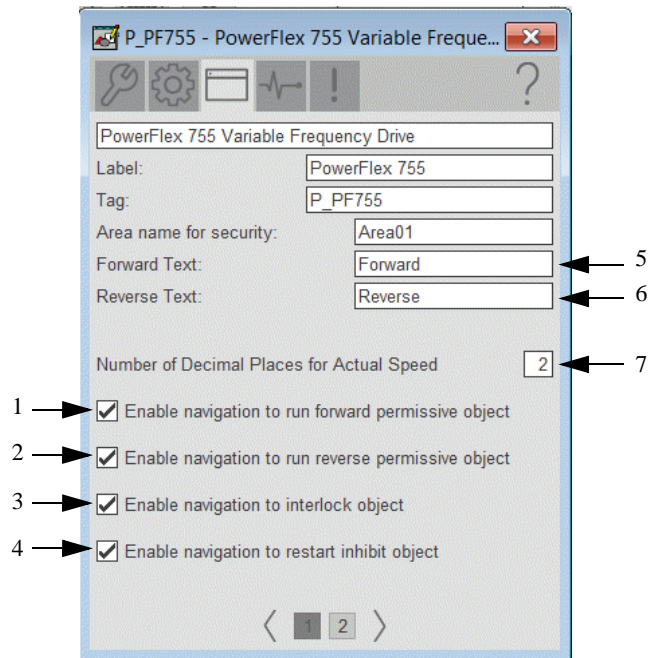
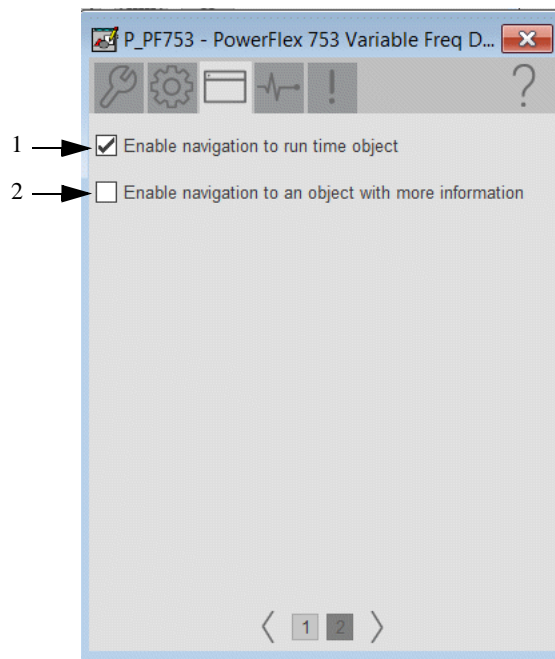


Table 238 - HMI Configuration Page 1 Description

Item	Description
1	Check if a permissive object is connected to Inp_FwdPermOK. The Permissive indicator becomes a button that opens the permissive faceplate. <b>IMPORTANT:</b> The name of the Forward Permissive object in the controller must be the name of the object with the suffix '_FwdPerm'. For example, if your P_PF52x object has the name 'Drive123', then its Forward Permissive object must be named 'Drive123_FwdPerm'.
2	Check if a permissive object is connected to Inp_RevPermOK. The Permissive indicator becomes a button that opens the permissive faceplate. <b>IMPORTANT:</b> The name of the Reverse Permissive object in the controller must be the name of the object with the suffix '_RevPerm'. For example, if your P_PF52x object has the name 'Drive123', then its Reverse Permissive object must be named 'Drive123_RevPerm'.
3	Check if an Interlock object is used with this motor. This check changes the Interlock indicator to a clickable button to open the Interlock faceplate. <b>IMPORTANT:</b> The name of the Interlock object in the controller must be the name of the object with the suffix '_Intlk'. For example, if your P_Motor object has the name 'Motor123', then its Interlock object must be named 'Motor123_Intlk'.
4	Check if a Restart Inhibit object is used with this motor. This check makes the Restart Inhibit button visible. <b>IMPORTANT:</b> The name of the Restart Inhibit object in the controller must be the name of the object with the suffix '_ResInh'. For example, if your P_Motor object has the name 'Motor123', then its Restart Inhibit object must be named 'Motor123_ResInh'.
5	Type a name for forward direction.
6	Type a name for reverse direction.
7	Type the number of decimal places to be shown for actual speed.



**Table 239 - HMI Configuration Page 2 Description**

Item	Description
1	<p>Check if a Run Time object is used with this motor. This check makes the Run Time button visible.</p> <p><b>IMPORTANT:</b> The name of the Run Time object in the controller must be the name of the object with the suffix ‘_RunTime’. For example, if your P_Motor object has the name ‘Motor123’, then its Run Time object must be named ‘Motor123_RunTime’.</p>
2	<p>Check to enable navigation to an object with more information (Cfg_HasMoreObj is set to true.)</p> <p>This can be configured to navigate to an AOI backing tag or a UDT tag that has HMI_Type and HMI_Lib defined.</p> <p>For example, there is a motor with the tag name P_101 and there is a need to have the more information button navigate to the parent P_LLS object. A tag is created for the P_LLS object that is given the alias P101_More. When the more information button is pressed on the motor, it links to P101_More. This will open the faceplate for the LLS object.</p>

## Diagnostics Tab

The Diagnostic tab provides indications that are helpful to diagnose or help prevent device problems. The device problems can include specific reasons a device is 'Not Ready', device warnings and faults, warning and fault history, and predictive/preventive maintenance data.

The Diagnostics tab displays possible reasons for the device not being ready. See [Diagnostics Tab on page 36](#)

## Alarms Tab

The Alarms tab displays each configured alarm. The icon on the tab for the alarms page changes color to show the current active alarm status. A blinking alarm icon indicates that one or more alarms must be acknowledged or the device must be reset. See [Common Alarm Block \(P\\_Alarm\) on page 66](#) for more information.

## Trends Tab

The Trends tab shows trend charts of key device data over time. These faceplate trends provide a quick view of current device performance to supplement, but not replace, dedicated historical or live trend displays. The trends displays are common across all Motors Family Add-On Instructions. See [Common Trends Tab - Motors on page 249](#)

## PowerFlex 6000 Drive (P\_PF6000)

The P\_PF6000 (PowerFlex 6000 drive) object is used to operate one PowerFlex 6000 Medium Voltage Variable Frequency Drive in various command sources and monitoring for fault conditions.

This document is for the visualization files, display elements, global objects, and HMI information. The operation of the Add-on Instructions and controller code is contained in publication [PROCES-RM013](#).

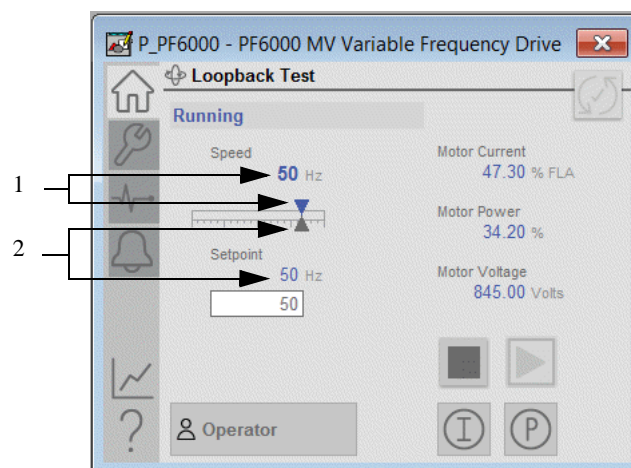
### Display Elements (P\_PF6000)

A display element (global object) is created once and can be referenced multiple times on multiple displays in an application. When changes are made to the original (base) object, the instantiated copies (reference objects) are automatically updated. Use of global objects, with tag structures in the ControlLogix system, aid consistency and save engineering time.

The P\_PF6000 instruction uses the same HMI display elements that are used for the Variable Speed Drive (P\_VSD) instruction. See [Display Elements \(P\\_VSD\) on page 299](#)

### Operator Tab

The Faceplate initially opens to the Operator (Home) tab. From here, an operator can monitor the device status and manually operate the device when it is in Operator command source. Several features are common to all Add-On Instructions faceplates for the motors family. See [Common Operator Tab - Motors on page 247](#).



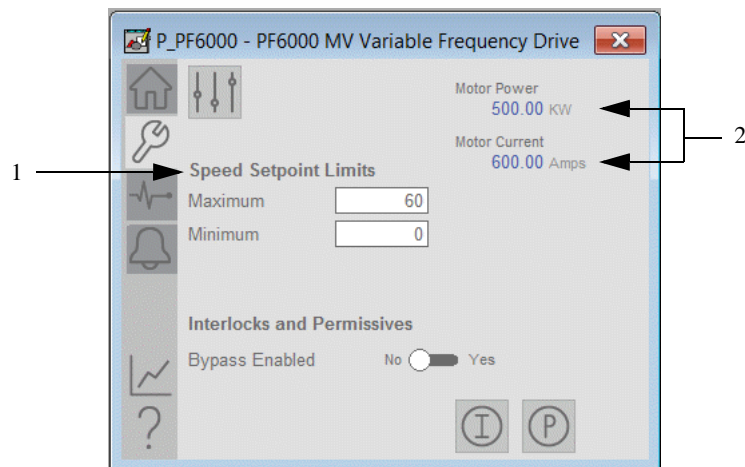
**Table 240 - Operator Tab Description**

Item	Description
1	Current speed of drive
2	Setpoint for the speed of the drive

## Maintenance Tab

Maintenance personnel use the information and controls on the Maintenance tab to adjust device parameters, troubleshoot, temporarily work around device problems, and disable the device for routine maintenance. Several features are common to all Add-On Instructions faceplates for the motors family.

See [Common Maintenance Tab - Motors on page 248](#)

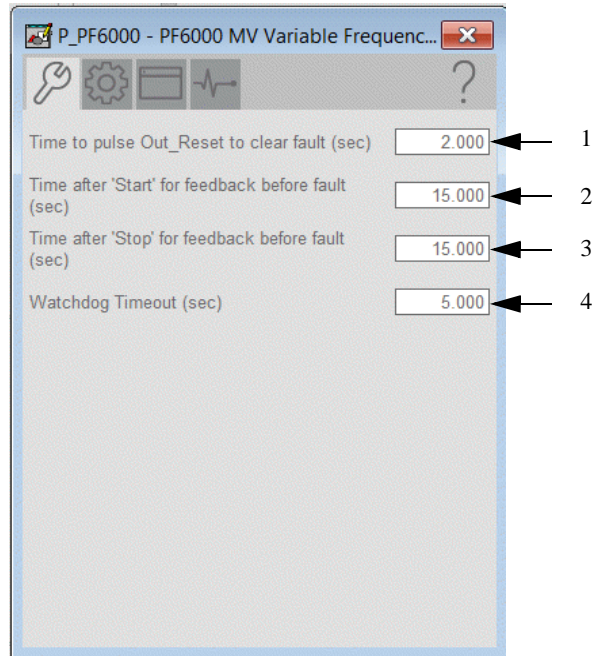
**Table 241 - Maintenance Tab Description**

Item	Description
1	Type the clamping limits for the speed setpoint. If a speed setpoint outside this range is entered, the speed is clamped at these limits and Sts_SpeedLimited is asserted.
2	Drive maintenance data.

## Advanced Properties Display

The Advanced Properties Display opens to the advanced maintenance settings. The Advanced Properties Display provides access to device configuration parameters and ranges, and options for device and I/O setup. This tab is used for initial system commissioning or later system changes.

*Advanced Maintenance Tab*



**Table 242 - Advanced Maintenance Tab Description**

Item	Description
1	Type the amount of time to hold Out_Reset true to reset a drive fault when a reset command is received.
2	Type the amount of time to allow for the run feedback of the drive to confirm that the drive has started before raising a Fail to Start alarm.
3	Type the amount of time to allow for the run feedback of the drive to confirm that the drive has stopped before raising a Fail to Stop alarm.
4	Type the maximum time allowed (in seconds) for the I/O communication to the drive to complete a read/write cycle before declaring a communication failure.



## Engineering Tab

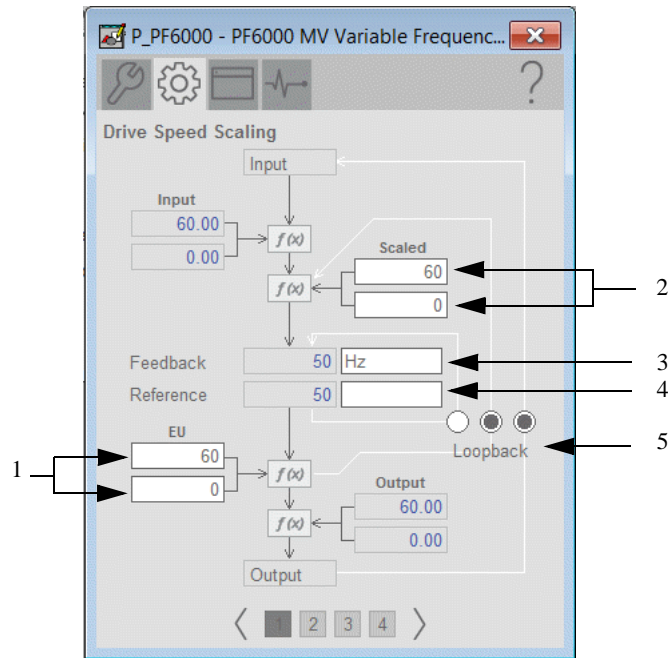
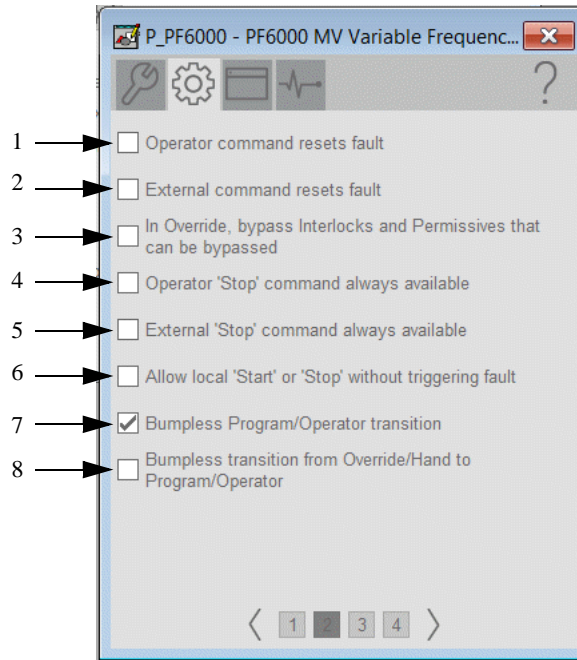


Table 243 - Engineering Tab Page 1 Description

Item	Description
1	Type the engineering unit value for the maximum and minimum (usually zero) speed reference sent to the drive. Do not enter a negative value for reversing drives. Reversing is handled separately.
2	Type the engineering unit value for the maximum and minimum (usually zero) speed feedback from the drive. Do not enter a negative value for reversing drives. Reversing is handled separately.
3	Type the text of the units of measure of the scaled speed feedback. (Often Hz, RPM, or Percent.)
4	Type the text of the units of measure of the scaled speed reference. (Often Hz, RPM, or Percent.)
5	Click the Simulation option (left, middle, or right) that corresponds to how the speed feedback for the drive is to be determined from the speed reference when the drive is being simulated (Inp_Sim = 1). Click the left option to copy the speed reference in engineering units to the speed feedback. (The simulated feedback is ramped to act like a drive that is accelerating or decelerating.) Use this option if the speed reference and speed feedback use the same scaling parameters Click the middle option to scale the simulated feedback from the speed-reference engineering unit range to the speed-feedback engineering unit range. Use this setting if the speed reference and speed feedback have different engineering ranges. For example, percent for reference and Hz for feedback), but the maximum reference (for example, 100%) corresponds to the maximum feedback (for example, 3600 RPM). Click the right option to scale the speed reference to raw units, copy the speed reference in raw units to speed feedback raw units, and scale to speed feedback engineering units. Use this setting if the reference and feedback ranges do not correspond.



**Table 244 - Engineering Tab Page 2 Description**

Item	Description
1	Check to reset faults on a new Operator command. Clear this checkbox if a reset is required to clear faults.
2	Check to reset faults on a new External command. Clear this checkbox if a reset is required to clear faults.
3	Check to have the interlocks and permissives that can be bypassed, bypassed in Override command source.
4	Check (= 1) so that the OCmd_Stop has priority and is accepted at any time. If the Command Source is not Operator or Maintenance, the motor or drive requires a reset. Clear this checkbox (= 0) so that the OCmd_Stop works only in Operator or Maintenance command source.
5	Check (= 1) so that the XCmd_Stop has priority and is accepted at any time. If the Command Source is not External, the motor or drive requires a reset. Clear this checkbox (= 0) so that the XCmd_Stop only works when the command source is External.
6	Check (= 1) to let local circuits start/stop the drive without an alarm. Clear this checkbox (= 0) to start/stop the drive from the HMI or program only.
7	Check to have program settings, such as Speed Reference, track operator settings in Operator command source, and have operator settings track Program Settings in Program command source.
8	Check to have the Program and Operator Speed Reference track the Override Speed Reference in Override command source or the actual speed in Hand command source.

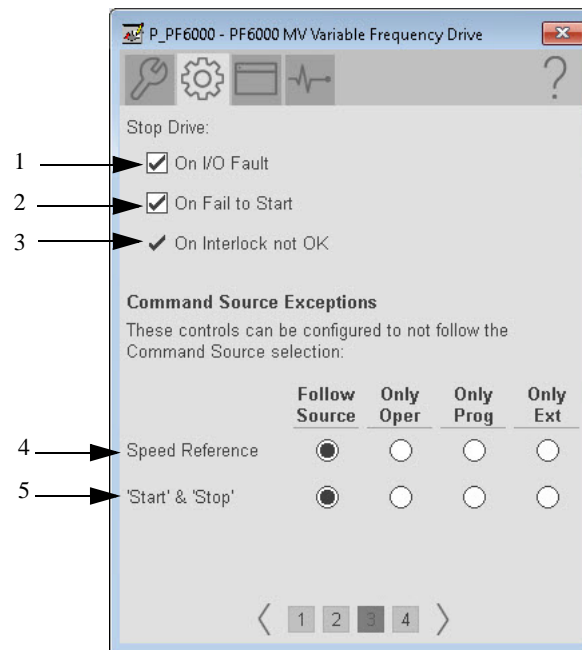
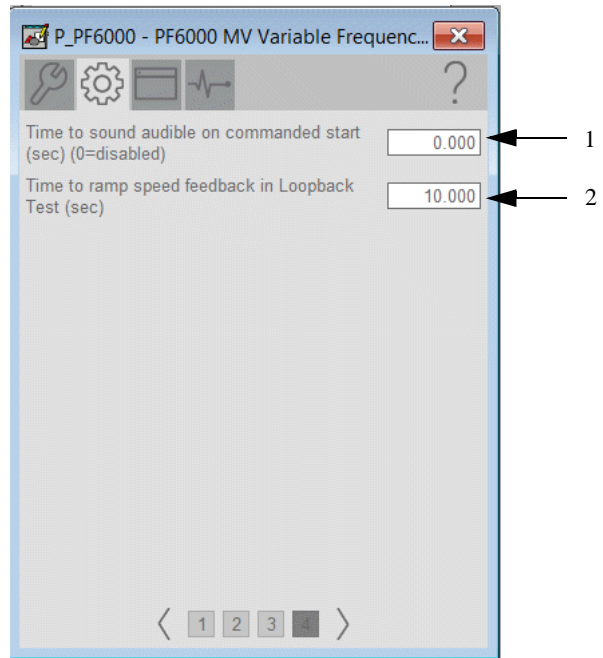


Table 245 - Engineering Tab Page 3 Description

Item	Description
1	Check to stop the drive if an I/O Fault is detected. After the I/O Fault clears, a reset is required before the drive can be started. Clear this checkbox to show only the I/O Fault Status/Alarm and not stop the drive if an I/O Fault is detected.
2	Check to stop the drive on a failure to start. A reset is required before another start can be attempted. Clear this checkbox to show only the Fail to Start status and alarm on a failure to start. The outputs are not changed, so the instruction continues to attempt to start the motor.
3	The drive always stops on an Interlock not OK. This item cannot be cleared. It is displayed as a reminder that the Interlock not OK function always stops the drive.
4	Check to keep control of the drive Speed Reference with the Operator, Program, External, or Follow the Source even if the instruction is in Program command source. Clear this checkbox to have control of the drive Speed Reference follow the Instruction command source.
5	Check to keep control of the drive Start and Stop commands with the Operator, Program, External, or Follow the Source, even if the instruction is in Operator command source. <b>IMPORTANT:</b> The Program cannot Jog the drive, even if Jogging is enabled. Clear this checkbox to have control of the drive Start, Stop, and Jog follow Instruction command source.

Table 246 - Engineering Tab Page 3 Description



**Table 247 - Engineering Tab Page 4 Description**

Item	Description
1	Type the time (in seconds) the audible alarm sounds on a commanded start.
2	Type the time, in seconds, to ramp speed feedback when in Simulation.

## HMI Configuration Tab

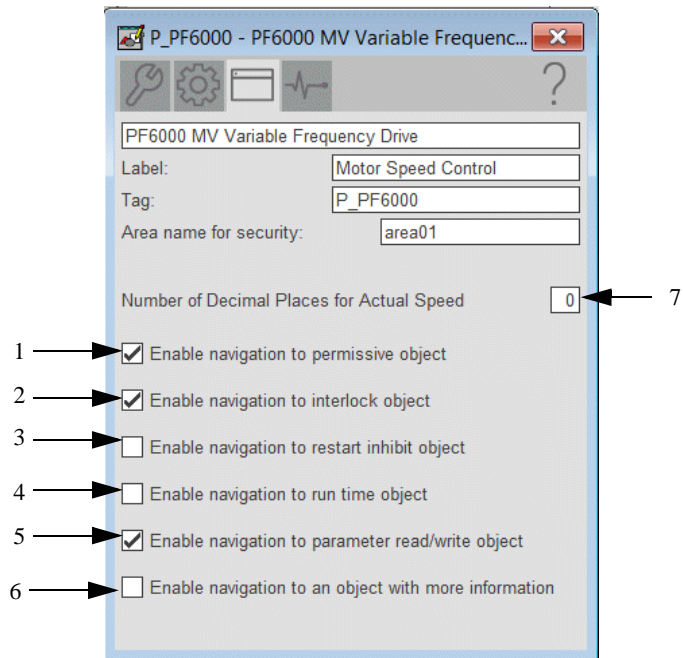


Table 248 - HMI Configuration Description

Item	Description
1	Check if a Permissive object is used with this motor. This check changes the Permissive indicator to a clickable button to open the Permissive faceplate. <b>IMPORTANT:</b> The name of the Permissive object in the controller must be the name of the object with the suffix '_Perm'. For example, if your P_Motor object has the name 'Motor123', then its Permissive object must be named 'Motor123_Perm'.
2	Check if an Interlock object is used with this motor. This check changes the Interlock indicator to a clickable button to open the Interlock faceplate. <b>IMPORTANT:</b> The name of the Interlock object in the controller must be the name of the object with the suffix '_Intlk'. For example, if your P_Motor object has the name 'Motor123', then its Interlock object must be named 'Motor123_Intlk'.
3	Check if a Restart Inhibit object is used with this motor. This check makes the Restart Inhibit button visible. <b>IMPORTANT:</b> The name of the Restart Inhibit object in the controller must be the name of the object with the suffix '_ResInh'. For example, if your P_Motor object has the name 'Motor123', then its Restart Inhibit object must be named 'Motor123_ResInh'.
4	Check if a Run Time object is used with this motor. This check makes the Run Time button visible. <b>IMPORTANT:</b> The name of the Run Time object in the controller must be the name of the object with the suffix '_RunTime'. For example, if your P_Motor object has the name 'Motor123', then its Run Time object must be named 'Motor123_RunTime'.
5	Check to enable navigation to the Parameter Read/Write object. This check makes the Parameter Read/Write object visible.

Item	Description
6	<p>Check to enable navigation to an object with more information (Cfg_HasMoreObj is set to true.)</p> <p>This can be configured to navigate to an AOI backing tag or a UDT tag that has HMI_Type and HMI_Lib defined.</p> <p>For example, there is a motor with the tag name P_101 and there is a need to have the more information button navigate to the parent P_LLS object. A tag is created for the P_LLS object that is given the alias P101_More. When the more information button is pressed on the motor, it links to P101_More. This will open the faceplate for the LLS object.</p>
7	Type the number of decimal places to be shown for actual speed.

## Diagnostics Tab

The Diagnostic tab provides indications that are helpful to diagnose or help prevent device problems. The device problems can include specific reasons a device is 'Not Ready', device warnings and faults, warning and fault history, and predictive/preventive maintenance data.

The Diagnostics tab displays possible reasons for the device not being ready. See [Diagnostics Tab on page 36](#)

## Alarms Tab

The Alarms tab displays each configured alarm. The icon on the tab for the alarms page changes color to show the current active alarm status. A blinking alarm icon indicates that one or more alarms must be acknowledged or the device must be reset. See [Common Alarm Block \(P\\_Alarm\) on page 66](#) for more information.

## Trends Tab

The Trends tab shows trend charts of key device data over time. These faceplate trends provide a quick view of current device performance to supplement, but not replace, dedicated historical or live trend displays. The trends displays are common across all Motors Family Add-On Instructions. See [Common Trends Tab - Motors on page 249](#)

## PowerFlex 7000 Drive (P\_PF7000)

The P\_PF7000 (PowerFlex 7000 drive) object is used to operate one PowerFlex 7000 Medium Voltage AC Drive in various command sources and monitoring for fault conditions.

This document is for the visualization files, display elements, global objects, and HMI information. The operation of the Add-on Instructions and controller code is contained in publication [PROCES-RM013](#).

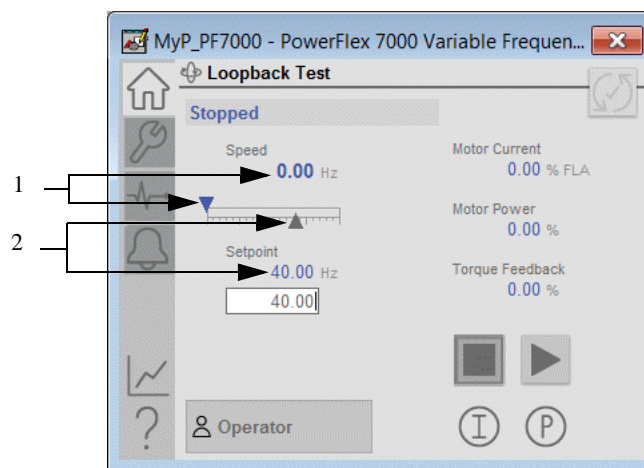
### Display Elements (P\_PF7000)

A display element (global object) is created once and can be referenced multiple times on multiple displays in an application. When changes are made to the original (base) object, the instantiated copies (reference objects) are automatically updated. Use of global objects, with tag structures in the ControlLogix system, aid consistency and save engineering time.

The P\_PF7000 instruction uses the same HMI display elements that are used for the Variable Speed Drive (P\_VSD) instruction. See [Display Elements \(P\\_VSD\) on page 299](#)

### Operator Tab

The Faceplate initially opens to the Operator (Home) tab. From here, an operator can monitor the device status and manually operate the device when it is in Operator command source. Several features are common to all Add-On Instructions faceplates for the motors family. See [Common Operator Tab - Motors on page 247](#).



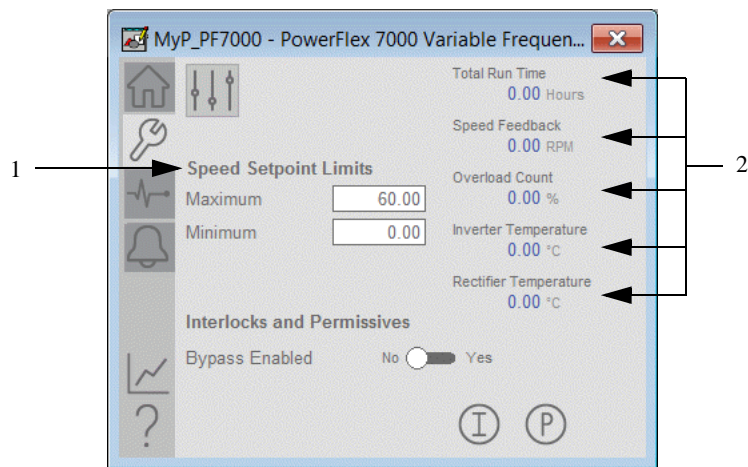
**Table 249 - Operator Tab Description**

Item	Description
1	Current speed of drive
2	Setpoint for the speed of the drive

## Maintenance Tab

Maintenance personnel use the information and controls on the Maintenance tab to adjust device parameters, troubleshoot, temporarily work around device problems, and disable the device for routine maintenance. Several features are common to all Add-On Instructions faceplates for the motors family.

See [Common Maintenance Tab - Motors on page 248](#)



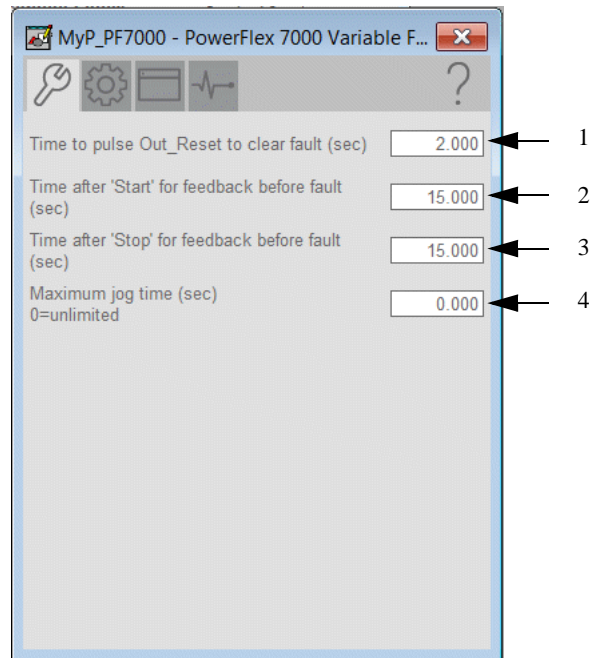
**Table 250 - Maintenance Tab Description**

Item	Description
1	Type the clamping limits for the speed setpoint. If a speed setpoint outside this range is entered, the speed is clamped at these limits and Sts_SpeedLimited is asserted.
2	Drive maintenance data.

## Advanced Properties Display

The Advanced Properties Display opens to the advanced maintenance settings. The Advanced Properties Display provides access to device configuration parameters and ranges, and options for device and I/O setup. This tab is used for initial system commissioning or later system changes.



*Advanced Maintenance Tab***Table 251 - Advanced Maintenance Tab Description**

Item	Description
1	Type the amount of time to hold Out_Reset true to reset a drive fault when a reset command is received.
2	Type the amount of time to allow for the run feedback of the drive to confirm that the drive has started before raising a Fail to Start alarm.
3	Type the amount of time to allow for the run feedback of the drive to confirm that the drive has stopped before raising a Fail to Stop alarm.
4	Type the maximum time (in seconds) that the drive can be jogged by using OCmd_Jog. <b>IMPORTANT:</b> This value stops drive jogging if HMI communication is lost during a jog.

Engineering Tab

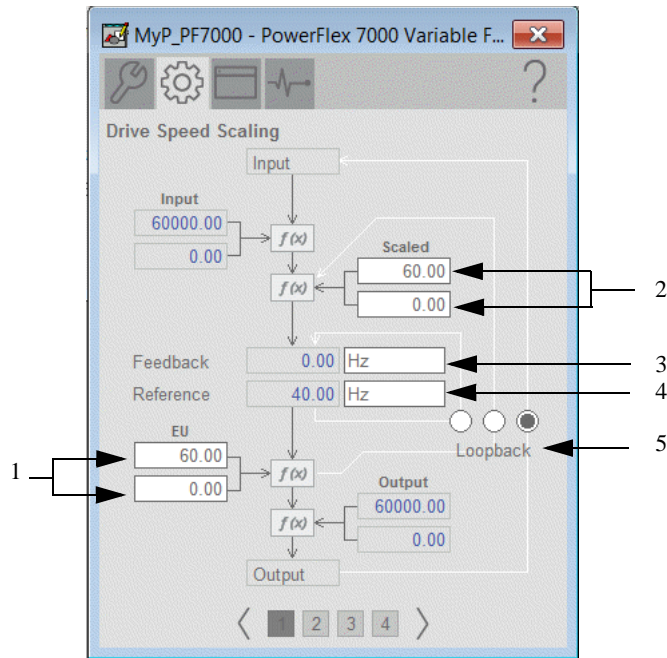
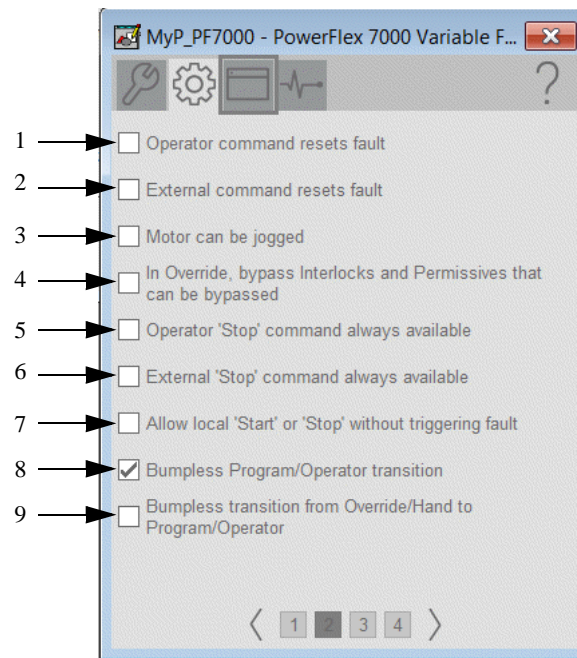
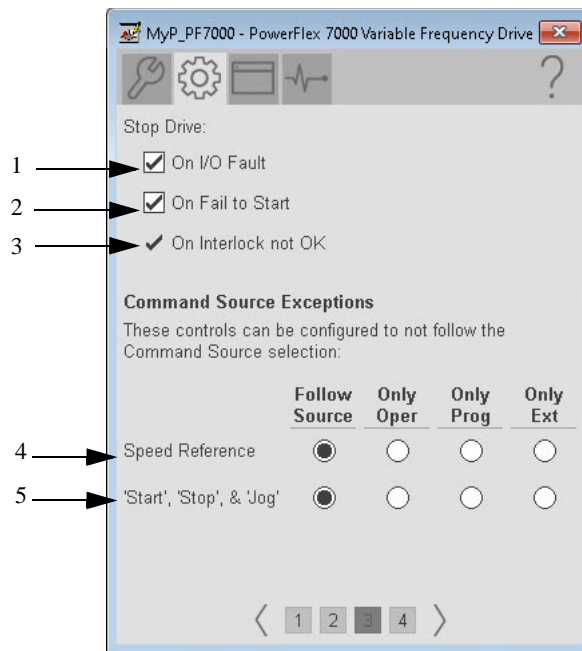


Table 252 - Engineering Tab Page 1 Description

Item	Description
1	Type the engineering unit value for the maximum and minimum (usually zero) speed reference sent to the drive. Do not enter a negative value for reversing drives. Reversing is handled separately.
2	Type the engineering unit value for the maximum and minimum (usually zero) speed feedback from the drive. Do not enter a negative value for reversing drives. Reversing is handled separately.
3	Type the text of the units of measure of the scaled speed feedback. (Often Hz, RPM, or Percent.)
4	Type the text of the units of measure of the scaled speed reference. (Often Hz, RPM, or Percent.)
5	Click the Simulation option (left, middle, or right) that corresponds to how the speed feedback for the drive is to be determined from the speed reference when the drive is being simulated (Inp_Sim = 1). Click the left option to copy the speed reference in engineering units to the speed feedback. (The simulated feedback is ramped to act like a drive that is accelerating or decelerating.) Use this option if the speed reference and speed feedback use the same scaling parameters Click the middle option to scale the simulated feedback from the speed-reference engineering unit range to the speed-feedback engineering unit range. Use this setting if the speed reference and speed feedback have different engineering ranges. For example, percent for reference and Hz for feedback), but the maximum reference (for example, 100%) corresponds to the maximum feedback (for example, 3600 RPM). Click the right option to scale the speed reference to raw units, copy the speed reference in raw units to speed feedback raw units, and scale to speed feedback engineering units. Use this setting if the reference and feedback ranges do not correspond.

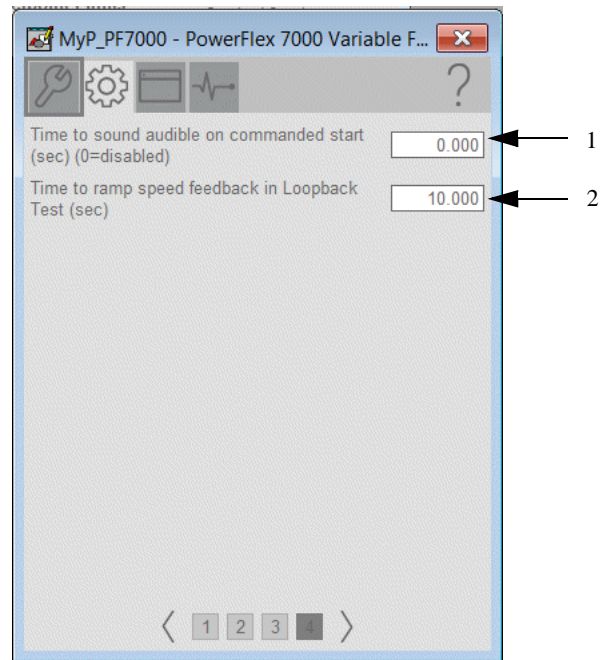
**Table 253 - Engineering Tab Page 2 Description**

Item	Description
1	Check to reset faults on a new Operator command. Clear this checkbox if a reset is required to clear faults.
2	Check to reset faults on a new External command. Clear this checkbox if a reset is required to clear faults.
3	Check to make the Jog command button visible on the Operator tab and enable the drive to be jogged from the faceplate
4	Check to have the interlocks and permissives that can be bypassed, bypassed in Override command source.
5	Check (= 1) so that the OCmd_Stop has priority and is accepted at any time. If the Command Source is not Operator or Maintenance, the motor or drive requires a reset. Clear this checkbox (= 0) so that the OCmd_Stop works only in Operator or Maintenance command source.
6	Check (= 1) so that the XCmd_Stop has priority and is accepted at any time. If the Command Source is not External, the motor or drive requires a reset. Clear this checkbox (= 0) so that the XCmd_Stop only works when the command source is External.
7	Check (= 1) to let local circuits start/stop the drive without an alarm. Clear this checkbox (= 0) to start/stop the drive from the HMI or program only.
8	Check to have program settings, such as Speed Reference, track operator settings in Operator command source, and have operator settings track Program Settings in Program command source.
9	Check to have the Program and Operator Speed Reference track the Override Speed Reference in Override command source or the actual speed in Hand command source.



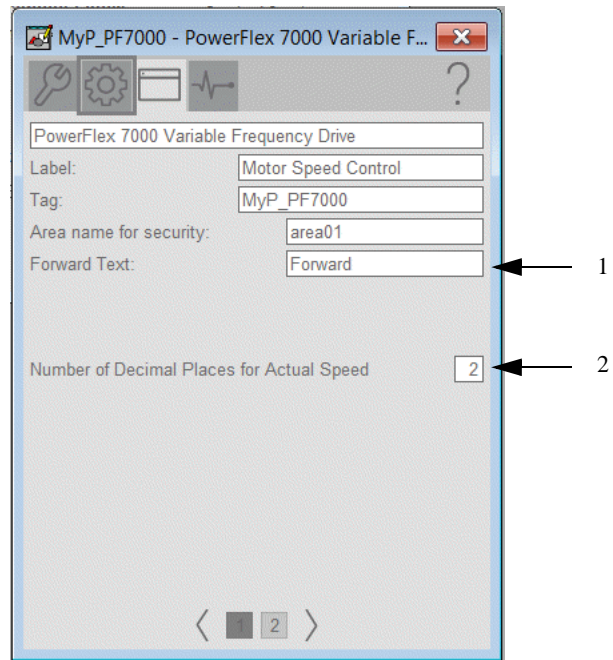
**Table 254 - Engineering Tab Page 3 Description**

Item	Description
1	Check to stop the drive if an I/O Fault is detected. After the I/O Fault clears, a reset is required before the drive can be started. Clear this checkbox to show only the I/O Fault Status/Alarm and not stop the drive if an I/O Fault is detected.
2	Check to stop the drive on a failure to start. A reset is required before another start can be attempted. Clear this checkbox to show only the Fail to Start status and alarm on a failure to start. The outputs are not changed, so the instruction continues to attempt to start the motor.
3	The drive always stops on an Interlock not OK. This item cannot be cleared. It is displayed as a reminder that the Interlock not OK function always stops the drive.
4	Check to keep control of the drive Speed Reference with the Operator, Program, External, or Follow the Source even if the instruction is in Program command source. Clear this checkbox to have control of the drive Speed Reference follow the Instruction command source.
5	Check to keep control of the drive Start and Stop commands with the Operator, Program, External, or Follow the Source, even if the instruction is in Operator command source. <b>IMPORTANT:</b> The Program cannot Jog the drive, even if Jogging is enabled. Clear this checkbox to have control of the drive Start, Stop, and Jog follow Instruction command source.

**Table 255 - Engineering Tab Page 4 Description**

Item	Description
1	Type the time (in seconds) the audible alarm sounds on a commanded start.
2	Type the time, in seconds, to ramp speed feedback when in Simulation.

*HMI Configuration Tab*



**Table 256 - HMI Configuration Tab Page 1 Description**

Item	Description
1	Type the text to display when the motor is running forward.
2	Type the number of decimal places to be shown for actual speed.

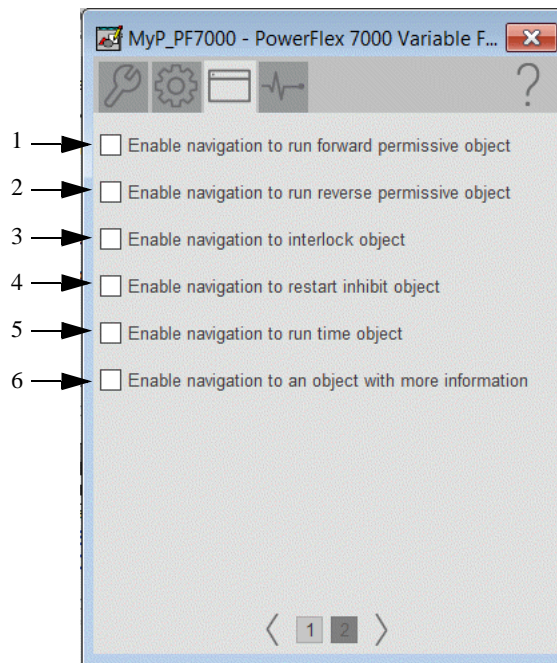


Table 257 - HMI Configuration Tab Page 2 Description

Item	Description
1	Check if a permissive object is connected to Inp_FwdPermOK. The Permissive indicator becomes a button that opens the permissive faceplate. <b>IMPORTANT:</b> The name of the Forward Permissive object in the controller must be the name of the object with the suffix '_FwdPerm'. For example, if your P_PF52x object has the name 'Drive123', then its Forward Permissive object must be named 'Drive123_FwdPerm'.
2	Check if a permissive object is connected to Inp_RevPermOK. The Permissive indicator becomes a button that opens the permissive faceplate. <b>IMPORTANT:</b> The name of the Reverse Permissive object in the controller must be the name of the object with the suffix '_RevPerm'. For example, if your P_PF52x object has the name 'Drive123', then its Reverse Permissive object must be named 'Drive123_RevPerm'.
3	Check if an Interlock object is used with this motor. This check changes the Interlock indicator to a clickable button to open the Interlock faceplate. <b>IMPORTANT:</b> The name of the Interlock object in the controller must be the name of the object with the suffix '_Intlk'. For example, if your P_Motor object has the name 'Motor123', then its Interlock object must be named 'Motor123_Intlk'.

Item	Description
4	<p>Check if a Restart Inhibit object is used with this motor. This check makes the Restart Inhibit button visible.</p> <p><b>IMPORTANT:</b> The name of the Restart Inhibit object in the controller must be the name of the object with the suffix ‘_ResInh’. For example, if your P_Motor object has the name ‘Motor123’, then its Restart Inhibit object must be named ‘Motor123_ResInh’.</p>
5	<p>Check if a Run Time object is used with this motor. This check makes the Run Time button visible.</p> <p><b>IMPORTANT:</b> The name of the Run Time object in the controller must be the name of the object with the suffix ‘_RunTime’. For example, if your P_Motor object has the name ‘Motor123’, then its Run Time object must be named ‘Motor123_RunTime’.</p>
6	<p>Check to enable navigation to an object with more information (Cfg_HasMoreObj is set to true.)</p> <p>This can be configured to navigate to an AOI backing tag or a UDT tag that has HMI_Type and HMI_Lib defined.</p> <p>For example, there is a motor with the tag name P_101 and there is a need to have the more information button navigate to the parent P_LLS object. A tag is created for the P_LLS object that is given the alias P101_More. When the more information button is pressed on the motor, it links to P101_More. This will open the faceplate for the LLS object.</p>

## Diagnostics Tab

The Diagnostic tab provides indications that are helpful to diagnose or help prevent device problems. The device problems can include specific reasons a device is ‘Not Ready’, device warnings and faults, warning and fault history, and predictive/preventive maintenance data.

The Diagnostics tab displays possible reasons for the device not being ready. See [Diagnostics Tab on page 36](#)

## Alarms Tab

The Alarms tab displays each configured alarm. The icon on the tab for the alarms page changes color to show the current active alarm status. A blinking alarm icon indicates that one or more alarms must be acknowledged or the device must be reset. See [Common Alarm Block \(P\\_Alarm\) on page 66](#) for more information.

## Trends Tab

The Trends tab shows trend charts of key device data over time. These faceplate trends provide a quick view of current device performance to supplement, but not replace, dedicated historical or live trend displays. The trends displays are common across all Motors Family Add-On Instructions. See [Common Trends Tab - Motors on page 249](#)



## SMC-50 Smart Motor Controller (P\_SMC50)


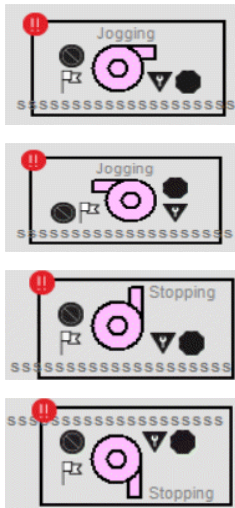

The P\_SMC50 (SMC™-50 Smart Motor Controller) Add-On Instruction controls and monitors a motor via an SMC-50 Smart Starter.

This document is for the visualization files, display elements, global objects, and HMI information. The operation of the Add-on Instructions and controller code is contained in publication [PROCES-RM013](#).

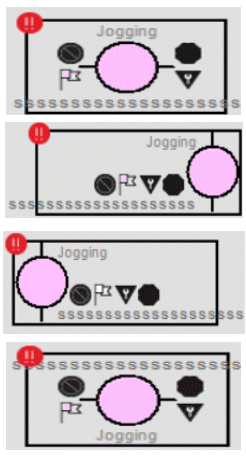
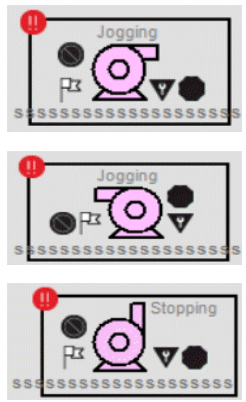

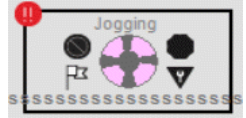
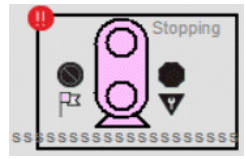

### Display Elements (P\_SMC50)

A display element (global object) is created once and can be referenced multiple times on multiple displays in an application. When changes are made to the original (base) object, the instantiated copies (reference objects) are automatically updated. Use of global objects, with tag structures in the ControlLogix system, aid consistency and save engineering time.

**Table 258 - P\_SMC50 Display Elements**

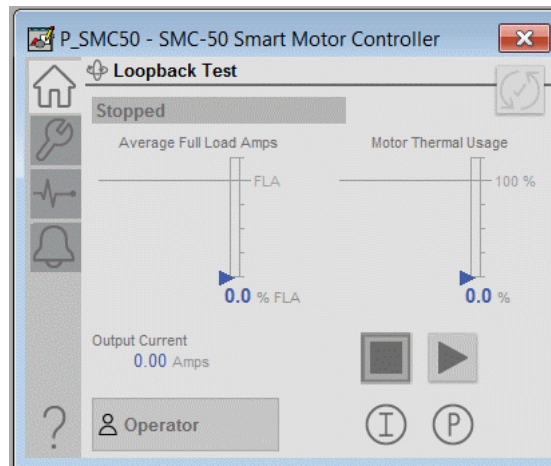
Display Element Name	Display Element	Description
GO_P_SMC_R GO_P_SMC_U GO_P_SMC_D		Motors operate in the right, up, and down positions.
GO_P_SMC_Blower_R GO_P_SMC_Blower_L GO_P_SMC_Blower_U GO_P_SMC_Blower_D		Blowers operate in the right, left, up, and down positions.
GO_P_SMC_Conveyer_U		Conveyer in the up position is shown as a display element.

**Table 258 - P\_SMC50 Display Elements**

Display Element Name	Display Element	Description
GO_P_SMC_Inline_U GO_P_SMC_Inline_R GO_P_SMC_Inline_L GO_P_SMC_Inline_D		Inline motors operate the up, right, left, and down positions.
GO_P_SMC_Pump_R GO_P_SMC_Pump_L GO_P_SMC_Pump_U		Pumps operate in the right, left, and up positions.
GO_P_SMC_Agitator_D		Agitator in the down position shown as a display element.
GO_P_SMC_Mixer_U		Mixer in the up position shown as a display element.
GO_P_SMC_RPump_U		Rotary gear pump in the up position shown as a display element.
GO_P_SMC_Fan_D		Fan in the down position shown as a display element.

## Operator Tab

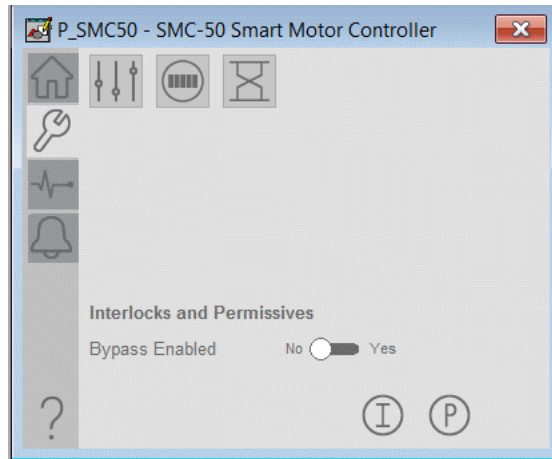
The Faceplate initially opens to the Operator (Home) tab. From here, an operator can monitor the device status and manually operate the device when it is in Operator command source. Several features are common to all Add-On Instructions faceplates for the motors family. See [Common Operator Tab - Motors on page 247](#).



## Maintenance Tab

Maintenance personnel use the information and controls on the Maintenance tab to adjust device parameters, troubleshoot, temporarily work around device problems, and disable the device for routine maintenance. Several features are common to all Add-On Instructions faceplates for the motors family.

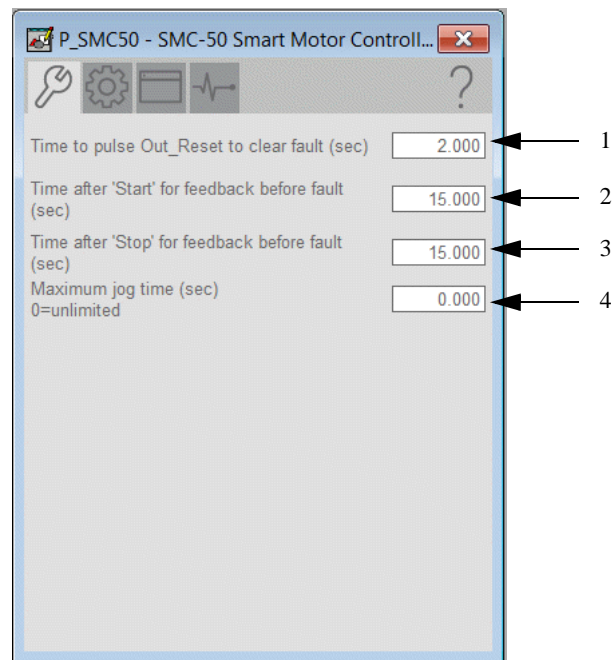
See [Common Maintenance Tab - Motors on page 248](#)



## Advanced Properties Display

The Advanced Properties Display opens to the advanced maintenance settings. The Advanced Properties Display provides access to device configuration parameters and ranges, and options for device and I/O setup. This tab is used for initial system commissioning or later system changes.

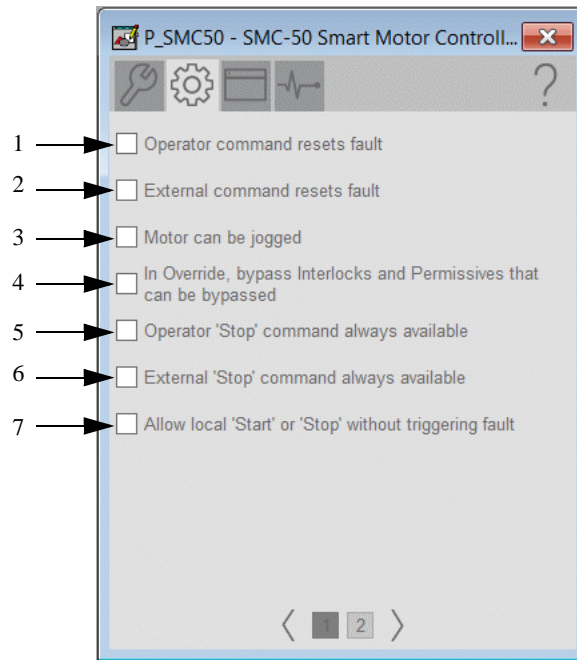
### Advanced Maintenance Tab



**Table 259 - Advanced Maintenance Tab Description**

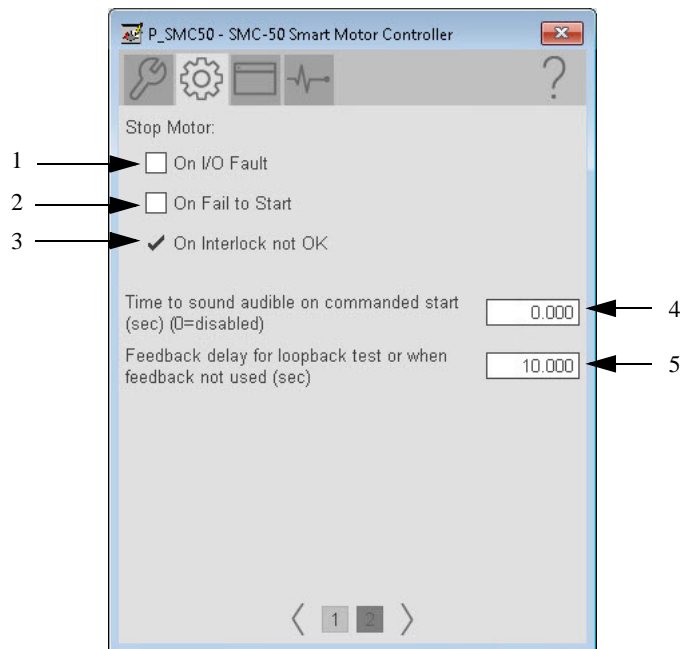
Item	Description
1	Type the amount of time to hold Out_Reset true to reset a drive fault when a reset command is received.
2	Type the amount of time for the run feedback of the drive to confirm that the drive has started before raising a Fail to Start alarm.
3	Type the amount of time for the run feedback of the drive to confirm that the drive has stopped before raising a Fail to Stop alarm.
4	Type the maximum amount of time allowed to jog the motor.

Engineering Tab



**Table 260 - Engineering Tab Page 1 Description**

Item	Description
1	Check to reset faults on a new Operator command. Clear this checkbox if a reset is required to clear faults.
2	Check to reset faults on a new External command. Clear this checkbox if a reset is required to clear faults.
3	Check to make the Jog command button visible on the Operator tab and enable the drive to be jogged from the faceplate
4	Check to have the interlocks and permissives that can be bypassed, bypassed in Override command source.
5	Check (= 1) so that the OCmd_Stop has priority and is accepted at any time. If the Command Source is not Operator or Maintenance, the motor or drive requires a reset. Clear this checkbox (= 0) so that the OCmd_Stop works only in Operator or Maintenance command source.
6	Check (= 1) so that the XCmd_Stop has priority and is accepted at any time. If the Command Source is not External, the motor or drive requires a reset. Clear this checkbox (= 0) so that the XCmd_Stop only works when the command source is External.
7	Check (= 1) to let local circuits start/stop the drive without an alarm. Clear this checkbox (= 0) to start/stop the drive from the HMI or program only.

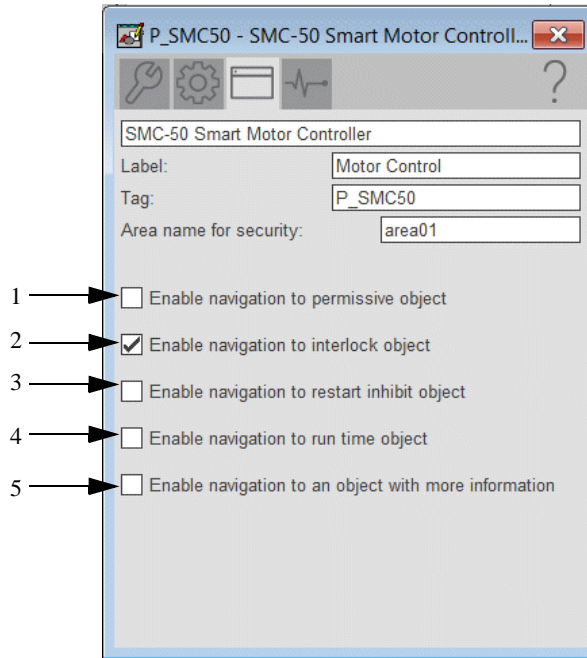


**Table 261 - Engineering Tab Page 2 Description**

Item	Description
1	Check to stop the drive if an I/O Fault is detected. After the I/O Fault clears, a reset is required before the drive can be started. Clear this checkbox to show only the I/O Fault Status/Alarm and not stop the drive if an I/O Fault is detected.
2	Check to stop the drive on a failure to start. A reset is required before another start can be attempted. Clear this checkbox to show only the Fail to Start status and alarm on a failure to start. The outputs are not changed, so the instruction continues to attempt to start the motor.
3	The drive always stops on an Interlock not OK. This item cannot be cleared. It is displayed as a reminder that the Interlock not OK function always stops the drive.
4	Type the time (in seconds) the audible alarm sounds on a commanded start.
5	Set the time delay (in seconds) for running or stopped status to be echoed back when the simulation is enabled or when run feedback is not used.

### HMI Configuration Tab

The HMI configuration tab provides access to displayed text, and faceplate-to-faceplate navigation settings. Configure the description, label, tag, and security area for the device. See [Basic Faceplate Attributes on page 32](#) for the description of the common attributes.



**Table 262 - HMI Configuration Tab Description**

Item	Description
1	Check if a Permissive object is used with this motor. This check changes the Permissive indicator to a clickable button to open the Permissive faceplate. <b>IMPORTANT:</b> The name of the Permissive object in the controller must be the name of the object with the suffix ‘_Perm’. For example, if your P_SMC50 object has the name ‘Motor123’, then its Permissive object must be named ‘Motor123_Perm’.
2	Check if an Interlock object is used with this motor. This check changes the Interlock indicator to a clickable button to open the Interlock faceplate. <b>IMPORTANT:</b> The name of the Interlock object in the controller must be the name of the object with the suffix ‘_Intlk’. For example, if your P_SMC50 object has the name ‘Motor123’, then its Interlock object must be named ‘Motor123_Intlk’.
3	Check if a Restart Inhibit object is used with this motor. This check makes the Restart Inhibit button visible. <b>IMPORTANT:</b> The name of the Restart Inhibit object in the controller must be the name of the object with the suffix ‘_ResInh’. For example, if your P_SMC50 object has the name ‘Motor123’, then its Restart Inhibit object must be named ‘Motor123_ResInh’.
4	Check if a Run Time object is used with this motor. This check makes the Run Time button visible. <b>IMPORTANT:</b> The name of the Run Time object in the controller must be the name of the object with the suffix ‘_RunTime’. For example, if your P_SMC50 object has the name ‘Motor123’, then its Run Time object must be named ‘Motor123_RunTime’.



---

<b>Item</b>	<b>Description</b>
5	<p>Check to enable navigation to an object with more information (Cfg_HasMoreObj is set to true.)</p> <p>This can be configured to navigate to an AOI backing tag or a UDT tag that has HMI_Type and HMI_Lib defined.</p> <p>For example, there is a motor with the tag name P_101 and there is a need to have the more information button navigate to the parent P_LLS object. A tag is created for the P_LLS object that is given the alias P101_More. When the more information button is pressed on the motor, it links to P101_More. This will open the faceplate for the LLS object.</p>

---

## Diagnostics Tab

The Diagnostic tab provides indications that are helpful to diagnose or help prevent device problems. The device problems can include specific reasons a device is 'Not Ready', device warnings and faults, warning and fault history, and predictive/preventive maintenance data.

The Diagnostics tab displays possible reasons for the device not being ready. See [Diagnostics Tab on page 36](#)

## Alarms Tab

The Alarms tab displays each configured alarm. The icon on the tab for the alarms page changes color to show the current active alarm status. A blinking alarm icon indicates that one or more alarms must be acknowledged or the device must be reset. See [Common Alarm Block \(P\\_Alarm\) on page 66](#) for more information.

## SMC Flex Smart Motor Controller (P\_SMCFlex)

This instruction controls and monitors a motor via an SMC Flex Smart Starter.

This document is for the visualization files, display elements, global objects, and HMI information. The operation of the Add-on Instructions and controller code is contained in publication [PROCES-RM013](#).

### Display Elements

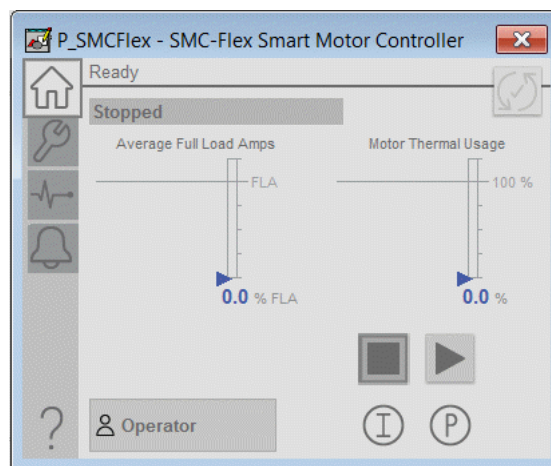
A display element (global object) is created once and can be referenced multiple times on multiple displays in an application. When changes are made to the original (base) object, the instantiated copies (reference objects) are automatically updated. Use of global objects, with tag structures in the ControlLogix system, aid consistency and save engineering time.

The P\_SMCFlex instruction uses the same HMI display elements that are used for the SMC-50 Smart Motor Controller (P\_SMC50) instruction. See [Display Elements \(P\\_SMC50\) on page 367](#)

### Operator Tab

The Faceplate initially opens to the Operator (Home) tab. From here, an operator can monitor the device status and manually operate the device when it is in Operator command source. Several features are common to all Add-On Instructions faceplates for the motors family. See [Common Operator Tab - Motors on page 247](#).

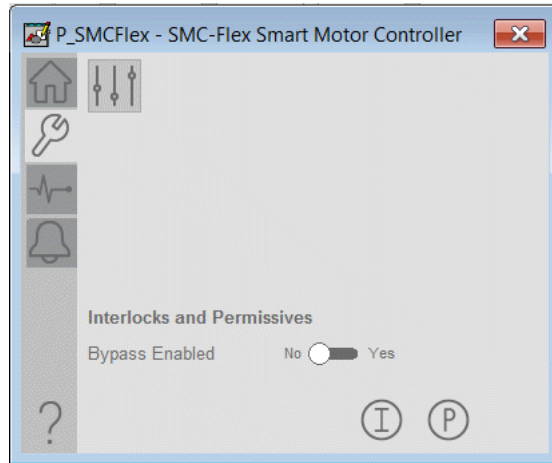
The operator tab for the P\_SMCFlex instruction also shows the average full load amps and the motor thermal usage.



## Maintenance Tab

Maintenance personnel use the information and controls on the Maintenance tab to adjust device parameters, troubleshoot, temporarily work around device problems, and disable the device for routine maintenance. Several features are common to all Add-On Instructions faceplates for the motors family.

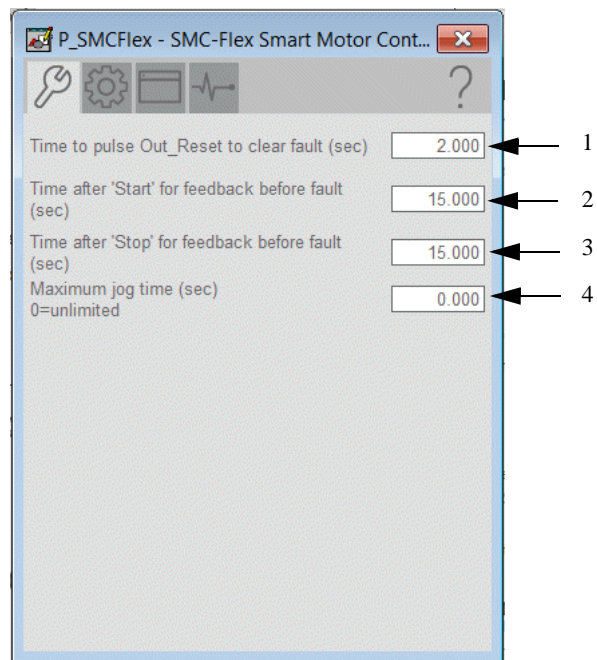
See [Common Maintenance Tab - Motors on page 248](#)



## Advanced Properties Display

The Advanced Properties Display opens to the advanced maintenance settings. The Advanced Properties Display provides access to device configuration parameters and ranges, and options for device and I/O setup. This tab is used for initial system commissioning or later system changes.

### Advanced Maintenance Tab



**Table 263 - Advanced Maintenance Tab Description**

Item	Description
1	Type the number of seconds the starter fault reset is pulsed to clear motor fault.
2	Type the time, in seconds to allow run feedback to show that the motor has started before raising a fail to start alarm.
3	Type the time, in seconds to allow run feedback to show that the motor has stopped before raising a fail to stop alarm.
4	Type the time, in seconds for the maximum amount of time to jog the motor.

Engineering Tab

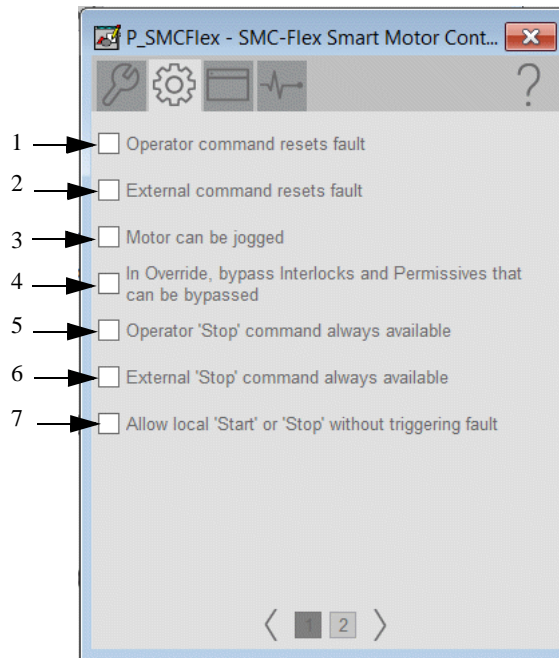
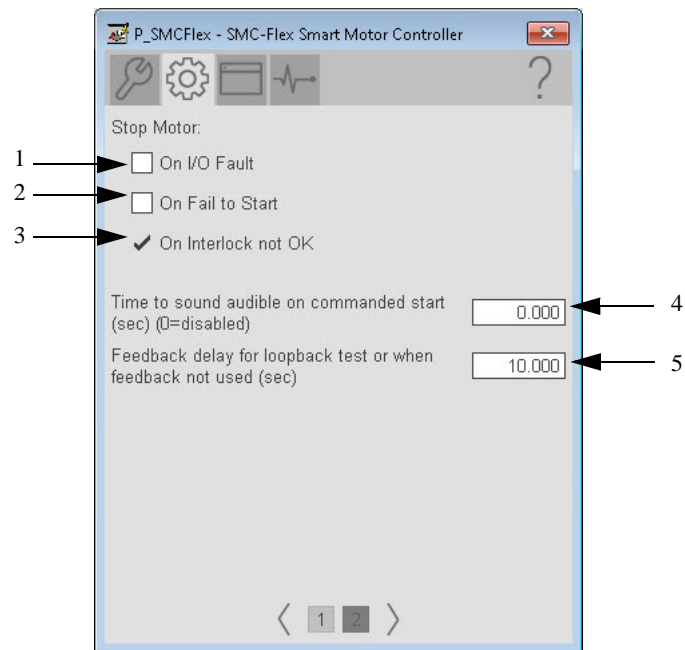


Table 264 - Engineering Tab Page 1 Description

Item	Description
1	Check to reset faults on a new Operator command. Clear this checkbox for 'reset required' to clear fault.
2	Check to reset faults on a new External command. Clear this checkbox for 'reset required' to clear fault.
3	Check to make the Jog command button visible on the Operator tab and enable the drive to be jogged from the faceplate.
4	Check to have the interlocks and permissives that can be bypassed, bypassed in Override command source.
5	Check (= 1) so that the OCmd_Stop has priority and is accepted at any time. If the Command Source is not Operator or Maintenance, the motor or drive requires a reset. Clear this checkbox (= 0) so that the OCmd_Stop works only in Operator or Maintenance command source.
6	Check (= 1) so that the XCmd_Stop has priority and is accepted at any time. If the Command Source is not External, the motor or drive requires a reset. Clear this checkbox (= 0) so that the XCmd_Stop only works when the command source is External.
7	Check to allow local Start/Stop without alarm. Clear this checkbox to allow start/stop by using only Program or Operator commands or Override Logic.

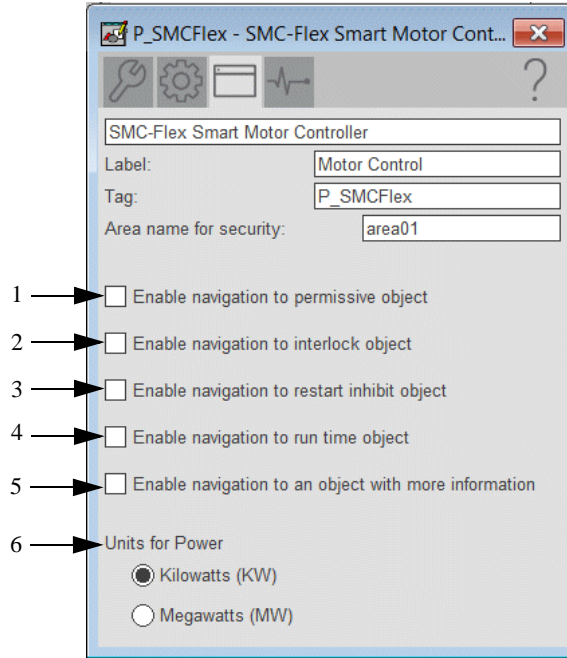


**Table 265 - Engineering Tab Page 2 Description**

Item	Description
1	Check to stop the drive if an I/O Fault is detected. After the I/O Fault clears, a reset is required before the drive can be started. Clear this checkbox to show only the I/O Fault Status/Alarm and not stop the drive if an I/O Fault is detected.
2	Check to stop the drive on a failure to start. A reset is required before another start can be attempted. Clear this checkbox to show only the Fail to Start status and alarm on a failure to start. The outputs are not changed, so the instruction continues to attempt to start the motor.
3	The drive always stops on an Interlock not OK. This item cannot be cleared. It is displayed as a reminder that the Interlock not OK function always stops the drive.
4	Type the time (in seconds) the audible alarm sounds on a commanded start.
5	Set the time delay (in seconds) for running or stopped status to be echoed back when the simulation is enabled or when run feedback is not used.

### HMI Configuration Tab

The HMI configuration tab provides access to displayed text, and faceplate-to-faceplate navigation settings. Configure the description, label, tag, and security area for the device. See [Basic Faceplate Attributes on page 32](#) for the description of the common attributes.



**Table 266 - HMI Configuration Tab Description**

Item	Description
1	Check if a Permissive object is used with this motor. This check changes the Permissive indicator to a clickable button to open the Permissive faceplate. <b>IMPORTANT:</b> The name of the Permissive object in the controller must be the name of the object with the suffix ‘_Perm’. For example, if your P_SMCFlex object has the name ‘Motor123’, then its Permissive object must be named ‘Motor123_Perm’.
2	Check if an Interlock object is used with this motor. This check changes the Interlock indicator to a clickable button to open the Interlock faceplate. <b>IMPORTANT:</b> The name of the Interlock object in the controller must be the name of the object with the suffix ‘_Intlk’. For example, if your P_SMCFlex object has the name ‘Motor123’, then its Interlock object must be named ‘Motor123_Intlk’.
3	Check if a Restart Inhibit object is used with this motor. This check makes the Restart Inhibit button visible. <b>IMPORTANT:</b> The name of the Restart Inhibit object in the controller must be the name of the object with the suffix ‘_ResInh’. For example, if your P_SMCFlex object has the name ‘Motor123’, then its Restart Inhibit object must be named ‘Motor123_ResInh’.



Item	Description
4	<p>Check if a Run Time object is used with this motor. This check makes the Run Time button visible.</p> <p><b>IMPORTANT:</b> The name of the Run Time object in the controller must be the name of the object with the suffix ‘_RunTime’. For example, if your P_SMCFlex object has the name ‘Motor123’, then its Run Time object must be named ‘Motor123_RunTime’.</p>
5	<p>Check to enable navigation to an object with more information (Cfg_HasMoreObj is set to true.)</p> <p>This can be configured to navigate to an AOI backing tag or a UDT tag that has HMI_Type and HMI_Lib defined.</p> <p>For example, there is a motor with the tag name P_101 and there is a need to have the more information button navigate to the parent P_LLS object. A tag is created for the P_LLS object that is given the alias P101_More. When the more information button is pressed on the motor, it links to P101_More. This will open the faceplate for the LLS object.</p>
6	Select the units, megawatts, or kilowatts, to be used for power.

## Diagnostics Tab

The Diagnostic tab provides indications that are helpful to diagnose or help prevent device problems. The device problems can include specific reasons a device is 'Not Ready', device warnings and faults, warning and fault history, and predictive/preventive maintenance data.

The Diagnostics tab displays possible reasons for the device not being ready. See [Diagnostics Tab on page 36](#)

## Alarms Tab

The Alarms tab displays each configured alarm. The icon on the tab for the alarms page changes color to show the current active alarm status. A blinking alarm icon indicates that one or more alarms must be acknowledged or the device must be reset. See [Common Alarm Block \(P\\_Alarm\) on page 66](#) for more information.

# E1 Plus Electronic Overload Relay (EtherNet/IP) (P\_E1PlusE)


The P\_E1PlusE (E1 Plus™ Electronic Overload Relay (EtherNet/IP)) Add-On Instruction controls and monitors an E1 Plus Electronic Overload Relay by using the 193-ETN EtherNet/IP interface module.

This document is for the visualization files, display elements, global objects, and HMI information. The operation of the Add-on Instructions and controller code is contained in publication [PROCES-RM013](#).

## Display Elements (EtherNet/IP) (P\_E1PlusE)

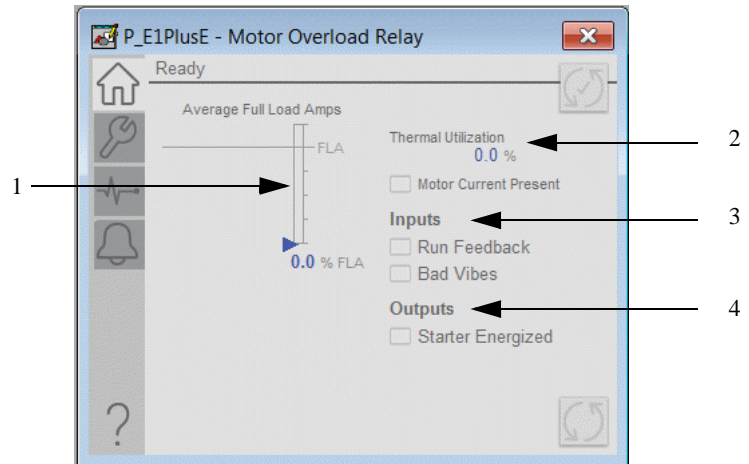
A display element (global object) is created once and can be referenced multiple times on multiple displays in an application. When changes are made to the original (base) object, the instantiated copies (reference objects) are automatically updated. Use of global objects, with tag structures in the ControlLogix system, aid consistency and save engineering time.

**Table 267 - P\_E1PlusE Display Element Description**

Display Element Name	Display Element	Description
GO_P_Ovld GO_P_Ovld1		Standard E1 Plus Electronic Overload Relay (EtherNet/IP) global objects.

## Operator Tab

The Faceplate initially opens to the Operator (Home) tab. From here, an operator can monitor the device status and manually operate the device when it is in Operator command source. Several features are common to all Add-On Instructions faceplates for the motors family. See [Common Operator Tab - Motors on page 247](#).



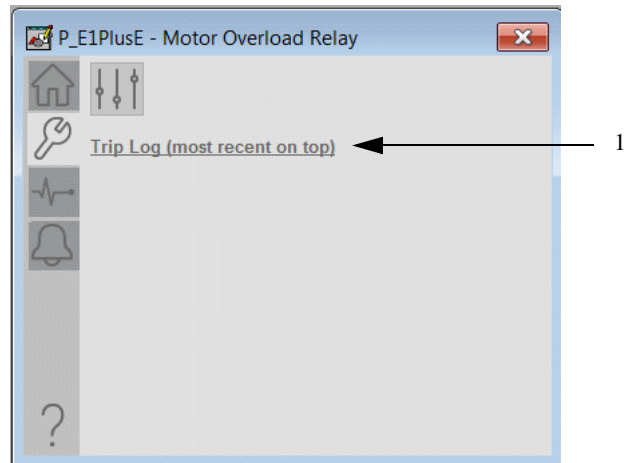
**Table 268 - Operator Tab Description**

Item	Description
1	Full load amps numeric display and sparkline
2	Thermal utilization
3	Input indicator
4	Output indicator

## Maintenance Tab

Maintenance personnel use the information and controls on the Maintenance tab to adjust device parameters, troubleshoot, temporarily work around device problems, and disable the device for routine maintenance. Several features are common to all Add-On Instructions faceplates for the motors family.

See [Common Maintenance Tab - Motors on page 248](#)



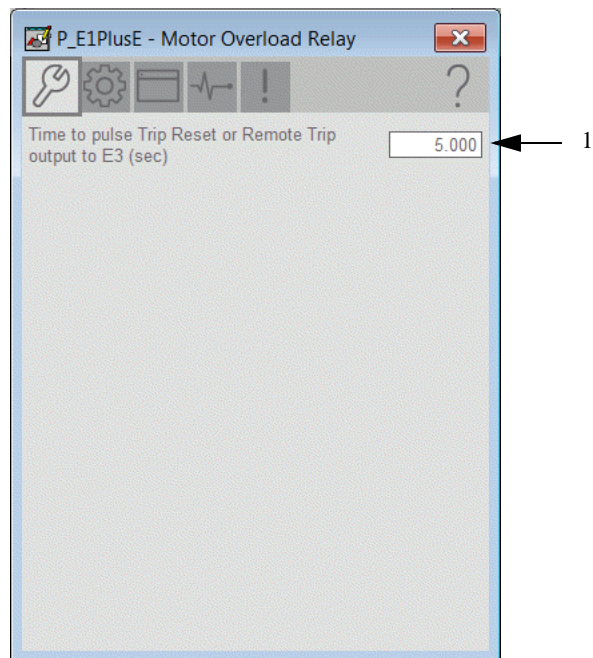
**Table 269 - Maintenance Tab Description**

Item	Description
1	Trip log

## Advanced Properties Display

The Advanced Properties Display opens to the advanced maintenance settings. The Advanced Properties Display provides access to device configuration parameters and ranges, and options for device and I/O setup. This tab is used for initial system commissioning or later system changes.

### *Advanced Maintenance Tab*



**Table 270 - Advanced Maintenance Tab Description**

Item	Description
1	Type the number of seconds (0...2,147,483) to pulse.

Engineering Tab

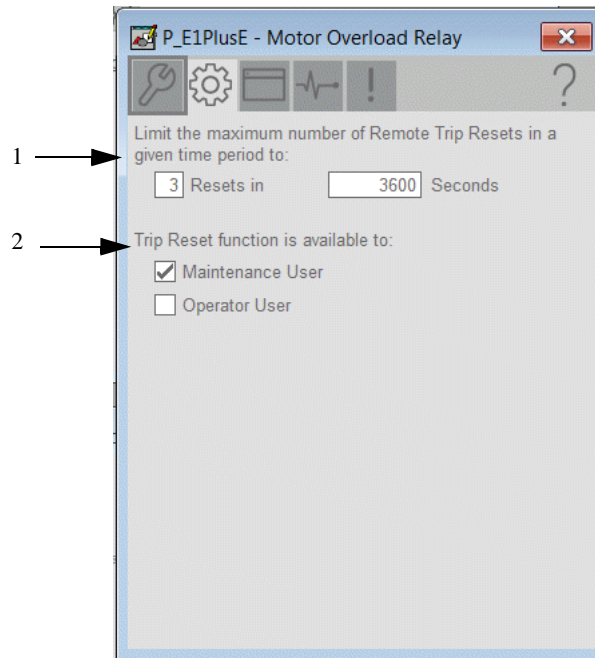
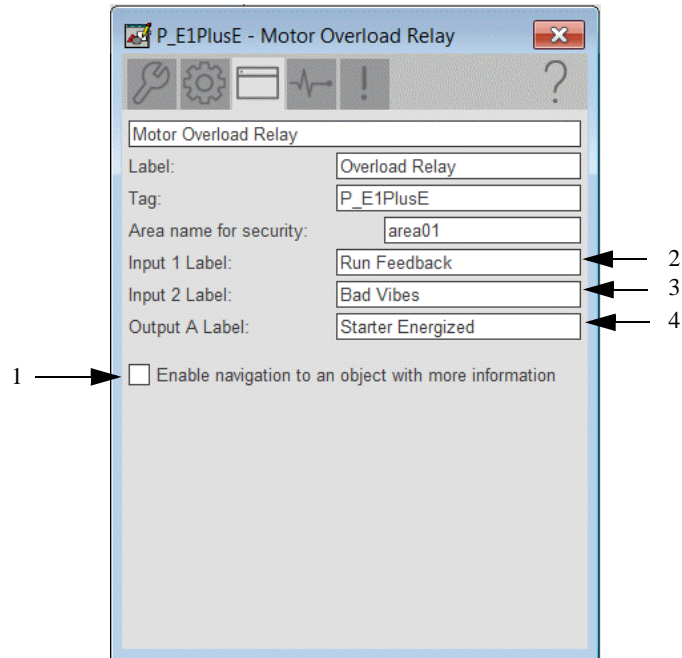


Table 271 - Engineering Tab Description

Item	Description
1	Type the number of seconds (0...2,147,483) to pulse.
2	Type the maximum number of resets (1...3) in a given number of seconds (0...2,147,483). <b>IMPORTANT:</b> Setting the time to approximately 10 seconds or less allows unlimited Remote Trip resets

## HMI Configuration Tab

The HMI configuration tab provides access to displayed text, and faceplate-to-faceplate navigation settings. Configure the description, label, tag, and security area for the device. See [Basic Faceplate Attributes on page 32](#) for the description of the common attributes.



**Table 272 - HMI Configuration Tab Description**

Item	Description
1	Check to enable navigation to an object with more information (Cfg_HasMoreObj is set to true.) This can be configured to navigate to an AOI backing tag or a UDT tag that has HMI_Type and HMI_Lib defined. For example, there is a motor with the tag name P_101 and there is a need to have the more information button navigate to the parent P_LLS object. A tag is created for the P_LLS object that is given the alias P101_More. When the more information button is pressed on the motor, it links to P101_More. This will open the faceplate for the LLS object.
2	Type the names for input 1
3	Type the names for input 2
4	Type the names for output A.

## Diagnostics Tab

The Diagnostic tab provides indications that are helpful to diagnose or help prevent device problems. The device problems can include specific reasons a device is 'Not Ready', device warnings and faults, warning and fault history, and predictive/preventive maintenance data.

The Diagnostics tab displays possible reasons for the device not being ready. See [Diagnostics Tab on page 36](#)

## Alarms Tab

The Alarms tab displays each configured alarm. The icon on the tab for the alarms page changes color to show the current active alarm status. A blinking alarm icon indicates that one or more alarms must be acknowledged or the device must be reset. See [Common Alarm Block \(P\\_Alarm\) on page 66](#) for more information.



## E3/E3 Plus Overload Relay (P\_E3Ovld)

The P\_E3Ovld Add-On Instruction controls and monitors a 193/592-EC1, -EC2, -EC3, or -EC5 overload relay.

This document is for the visualization files, display elements, global objects, and HMI information. The operation of the Add-on Instructions and controller code is contained in publication [PROCES-RM013](#).

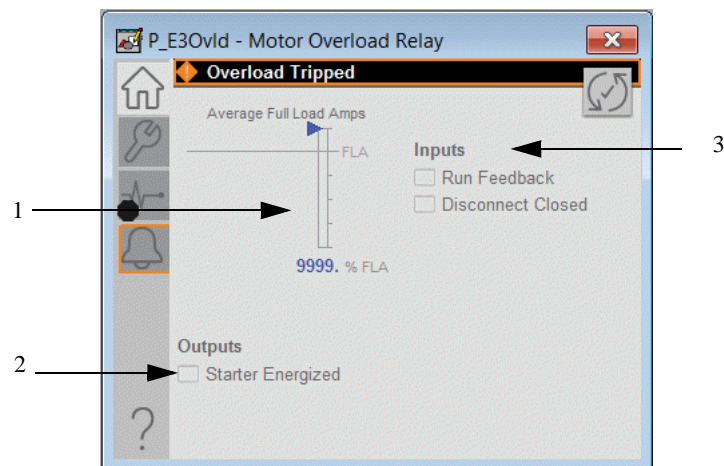
### Display Elements

A display element (global object) is created once and can be referenced multiple times on multiple displays in an application. When changes are made to the original (base) object, the instantiated copies (reference objects) are automatically updated. Use of global objects, with tag structures in the ControlLogix system, aid consistency and save engineering time.

The P\_E3Ovld instruction uses the same HMI display elements that are used for the E1 Plus Overload Relay (EtherNet/IP) (P\_E1PlusE) instruction. See [Display Elements \(EtherNet/IP\) \(P\\_E1PlusE\) on page 384](#)

### Operator Tab

The Faceplate initially opens to the Operator (Home) tab. From here, an operator can monitor the device status and manually operate the device when it is in Operator command source. Several features are common to all Add-On Instructions faceplates for the motors family.



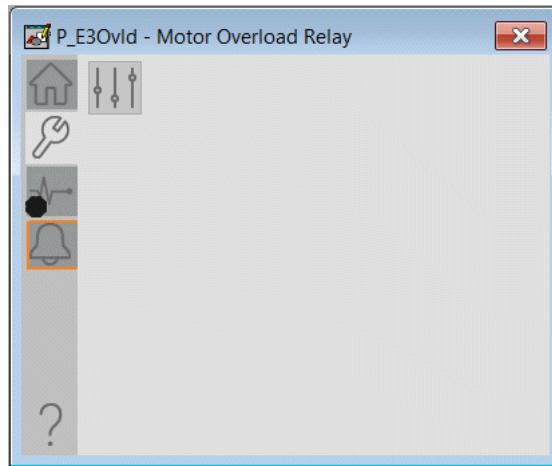
**Table 273 - Operator Tab Description**

Item	Description
1	Overload status indicator.
2	Outputs (up to 2).
3	Inputs (up to 4).

## Maintenance Tab

Maintenance personnel use the information and controls on the Maintenance tab to adjust device parameters, troubleshoot, temporarily work around device problems, and disable the device for routine maintenance. Several features are common to all Add-On Instructions faceplates for the motors family.

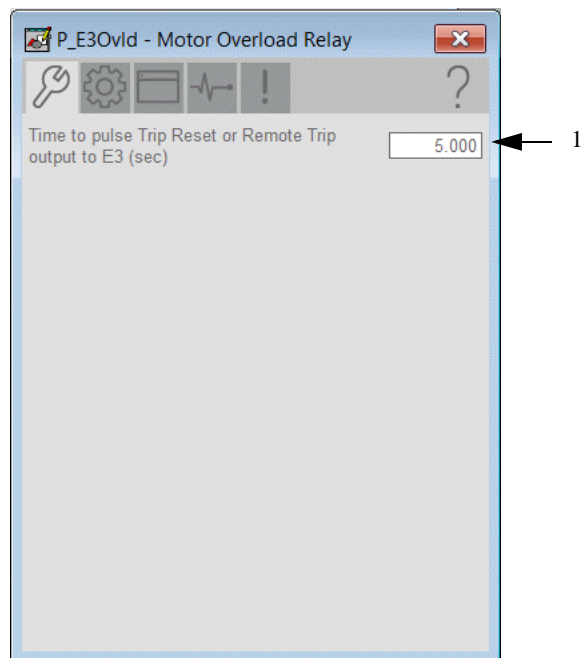
See [Common Maintenance Tab - Motors on page 248](#)



## Advanced Properties Display

The Advanced Properties Display opens to the advanced maintenance settings. The Advanced Properties Display provides access to device configuration parameters and ranges, and options for device and I/O setup. This tab is used for initial system commissioning or later system changes.

### *Advanced Maintenance Tab*



**Table 274 - Advanced Maintenance Tab Description**

Item	Description
1	Type the number of seconds (0...2,147,483) to pulse.

Engineering Tab

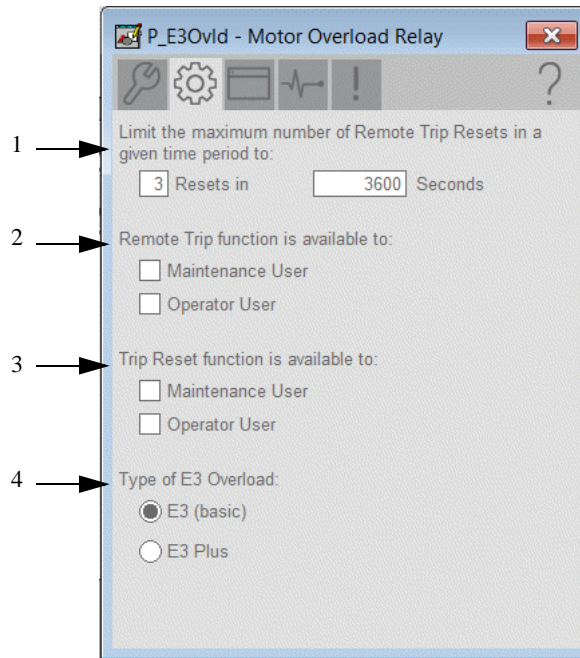
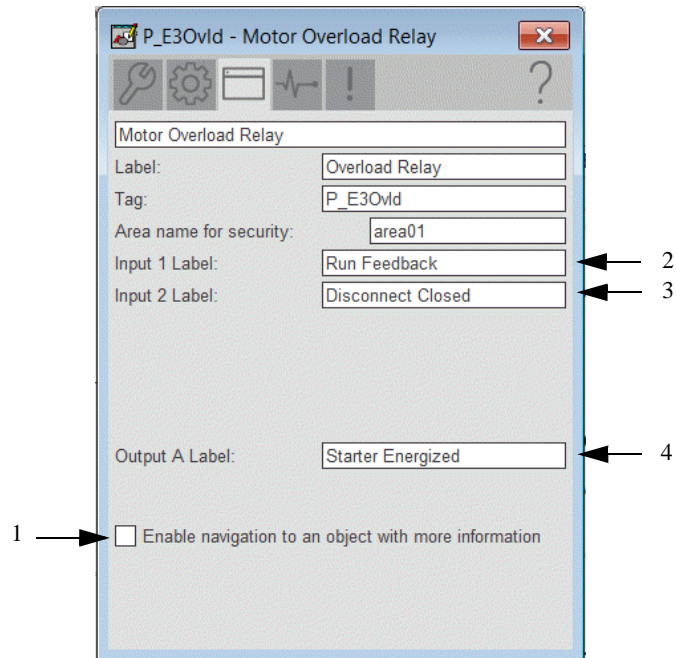


Table 275 - Engineering Tab Description

Item	Description
1	Type the maximum number of resets (1...3) in a given number of seconds (0...2,147,483). <b>IMPORTANT:</b> Setting the time to approximately 10 seconds or less allows unlimited Remote Trip resets
2	Check to let the Maintenance and/or Operator User use the Remote Trip function.
3	Check to let the Maintenance and/or Operator User use the Trip Reset function.
4	Click to select the type of E3 Overload used. <b>IMPORTANT:</b> E3 Plus has two additional inputs and one additional output.

## HMI Configuration Tab

The HMI configuration tab provides access to displayed text, and faceplate-to-faceplate navigation settings. Configure the description, label, tag, and security area for the device. See [Basic Faceplate Attributes on page 32](#) for the description of the common attributes.



**Table 276 - HMI Tab Description**

Item	Description
1	<p>Check to enable navigation to an object with more information (Cfg_HasMoreObj is set to true.)</p> <p>This can be configured to navigate to an AOI backing tag or a UDT tag that has HMI_Type and HMI_Lib defined.</p> <p>For example, there is a motor with the tag name P_101 and there is a need to have the more information button navigate to the parent P_LLS object. A tag is created for the P_LLS object that is given the alias P101_More. When the more information button is pressed on the motor, it links to P101_More. This will open the faceplate for the LLS object.</p>
2	Type the names for input 1
3	Type the names for input 2
4	Type the names for output A.

## Diagnostics Tab

The Diagnostic tab provides indications that are helpful to diagnose or help prevent device problems. The device problems can include specific reasons a device is 'Not Ready', device warnings and faults, warning and fault history, and predictive/preventive maintenance data.

The Diagnostics tab displays possible reasons for the device not being ready. See [Diagnostics Tab on page 36](#)

## Alarms Tab

The Alarms tab displays each configured alarm. The icon on the tab for the alarms page changes color to show the current active alarm status. A blinking alarm icon indicates that one or more alarms must be acknowledged or the device must be reset. See [Common Alarm Block \(P\\_Alarm\) on page 66](#) for more information.

## E300 Electronic Overload Relay (EtherNet/IP) (P\_E300Ovld)

The P\_E300Ovld (E300™ Electronic Overload Relay) Add-On Instruction controls and monitors a 193-ECM-ETR (E300 on EtherNet/IP) overload relay.

This document is for the visualization files, display elements, global objects, and HMI information. The operation of the Add-on Instructions and controller code is contained in publication [PROCES-RM013](#).

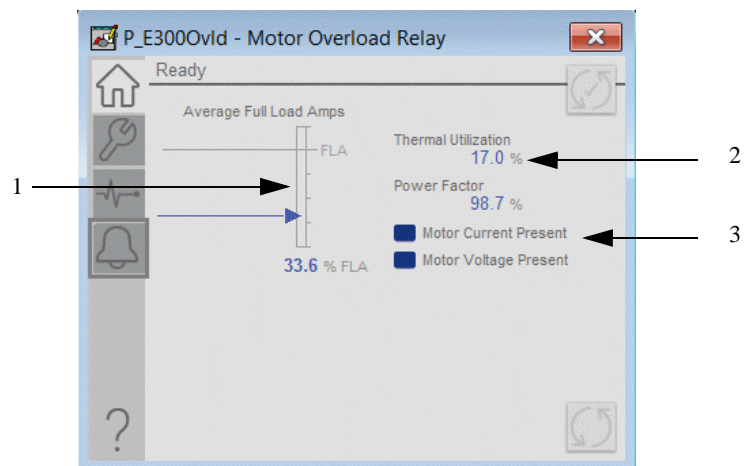
### Display Elements

A display element (global object) is created once and can be referenced multiple times on multiple displays in an application. When changes are made to the original (base) object, the instantiated copies (reference objects) are automatically updated. Use of global objects, with tag structures in the ControlLogix system, aid consistency and save engineering time.

The (EtherNet/IP) (P\_E300Ovld) instruction uses the same HMI display elements that are used for the E1 Plus Overload Relay (EtherNet/IP) (P\_E1PlusE) instruction. See [Display Elements \(EtherNet/IP\) \(P\\_E1PlusE\) on page 384](#)

### Operator Tab

The Faceplate initially opens to the Operator (Home) tab. From here, an operator can monitor the device status and manually operate the device when it is in Operator command source. Several features are common to all Add-On Instructions faceplates for the motors family. See [Common Operator Tab - Motors on page 247](#).



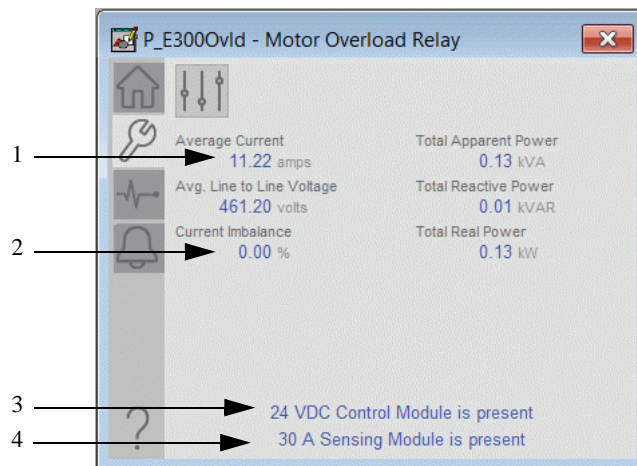
**Table 277 - Operator Tab Description**

Item	Description
1	Overload status indicator.
2	Thermal utilization.
3	Motor current indicator.

## Maintenance Tab

Maintenance personnel use the information and controls on the Maintenance tab to adjust device parameters, troubleshoot, temporarily work around device problems, and disable the device for routine maintenance. Several features are common to all Add-On Instructions faceplates for the motors family.

See [Common Maintenance Tab - Motors on page 248](#)



**Table 278 - Maintenance Tab Description**

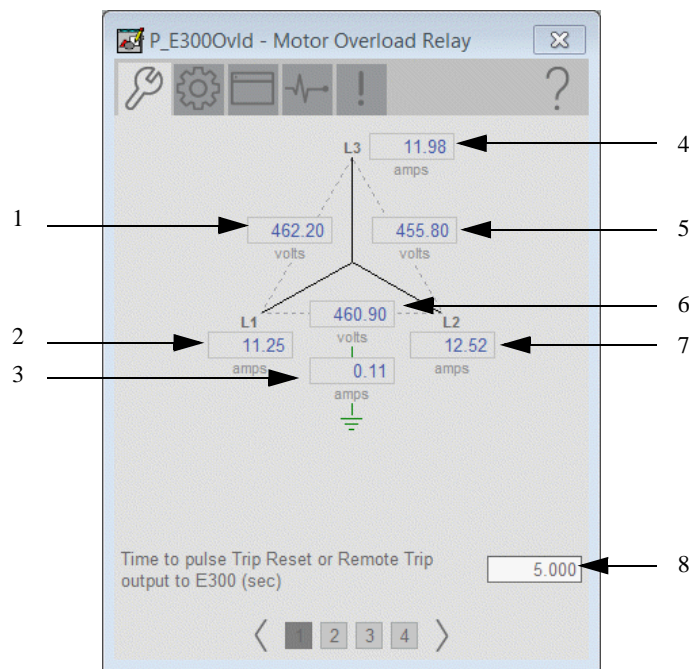
Item	Description
1	Average current.
2	Current imbalance.
3	Control module status.
4	Sensing module status.



## Advanced Properties Display

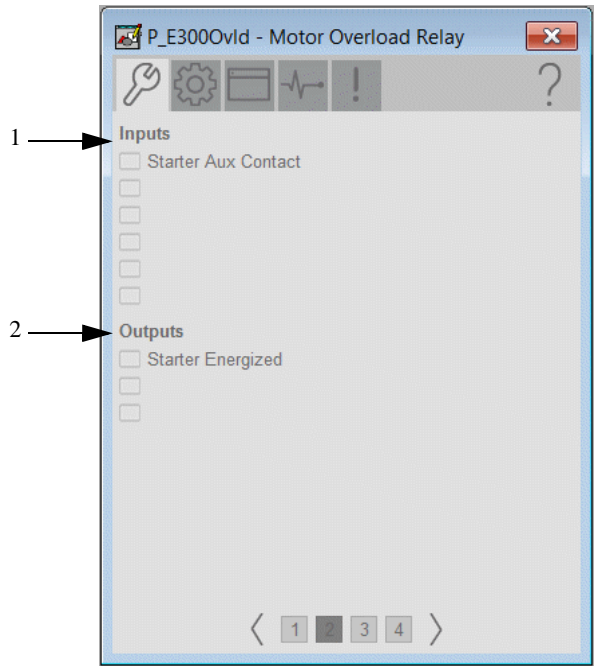
The Advanced Properties Display opens to the advanced maintenance settings. The Advanced Properties Display provides access to device configuration parameters and ranges, and options for device and I/O setup. This tab is used for initial system commissioning or later system changes.

### Advanced Maintenance Tab



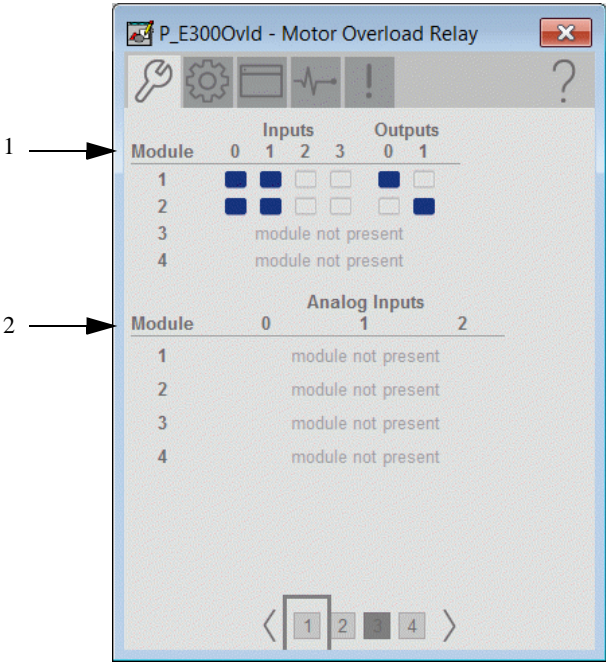
**Table 279 - Advanced Maintenance Tab Page 1 Description**

Item	Description
1	L3-L1 phase voltage.
2	L1 current.
3	Current to ground.
4	L3 current.
5	L3-L2 phase voltage.
6	L2-L1 phase voltage.
7	L2 current.
8	Type the number of seconds (0...2,147,483) to pulse.



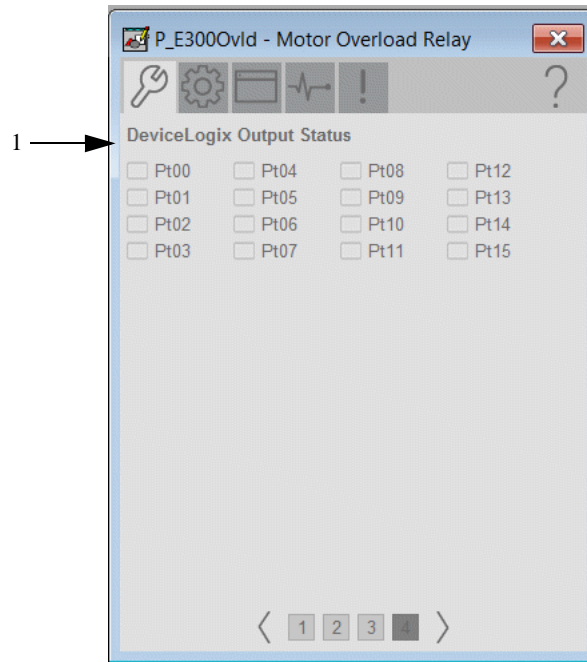
**Table 280 - Advanced Maintenance Tab Page 2 Description**

Item	Description
1	Up to six inputs.
2	Up to three outputs.



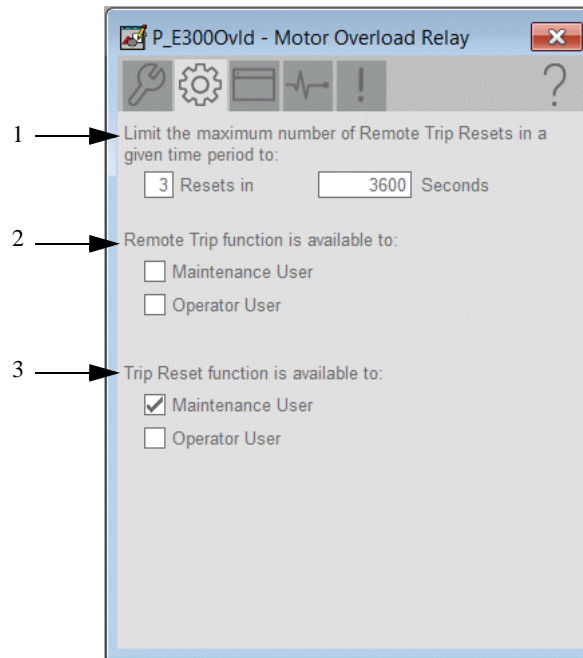
**Table 281 - Advanced Maintenance Tab Page 3 Description**

Item	Description
1	Status of up to four digital I/O modules. Indicators for up to four discrete inputs and up to two discrete outputs.
2	Status of up to four analog input modules. Indicators for the three analog inputs.



**Table 282 - Advanced Maintenance Tab Page 4 Description**

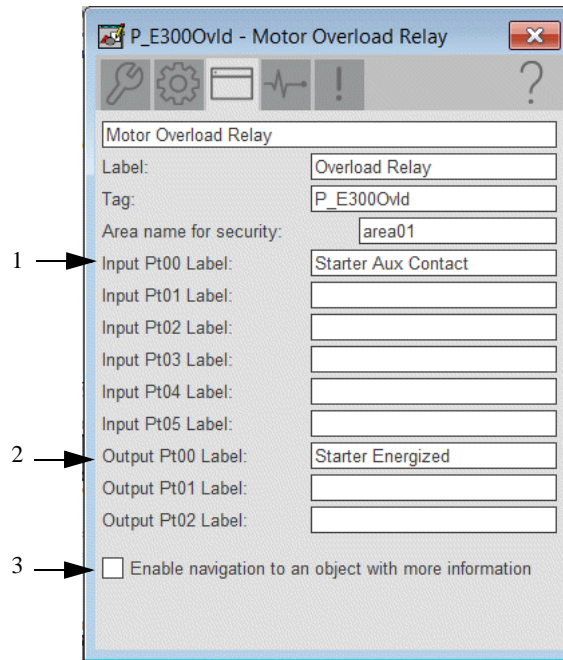
Item	Description
1	Indicators for the DeviceLogix™ output status.

*Engineering Tab***Table 283 - Engineering Tab Description**

Item	Description
1	Type the maximum number of resets (1...3) in a given number of seconds (0...2,147,483). <b>IMPORTANT:</b> Set the time to approximately 10 seconds or less to allow unlimited Remote Trip resets.
2	Check to let the Maintenance and/or Operator User use the Remote Trip function.
3	Check to let the Maintenance and/or Operator User use the Trip Reset function.

### HMI Configuration Tab

The HMI configuration tab provides access to displayed text, and faceplate-to-faceplate navigation settings. Configure the description, label, tag, and security area for the device. See [Basic Faceplate Attributes on page 32](#) for the description of the common attributes.



**Table 284 - HMI Configuration Tab Description**

Item	Description
1	Type the names for inputs Pt00...Pt05.
2	Type the names for outputs 1 and 2.
3	Check to enable navigation to an object with more information (Cfg_HasMoreObj is set to true.) This can be configured to navigate to an AOI backing tag or a UDT tag that has HMI_Type and HMI_Lib defined. For example, there is a motor with the tag name P_101 and there is a need to have the more information button navigate to the parent P_LLS object. A tag is created for the P_LLS object that is given the alias P101_More. When the more information button is pressed on the motor, it links to P101_More. This will open the faceplate for the LLS object.

## **Diagnostics Tab**

The Diagnostic tab provides indications that are helpful to diagnose or help prevent device problems. The device problems can include specific reasons a device is 'Not Ready', device warnings and faults, warning and fault history, and predictive/preventive maintenance data.

The Diagnostics tab displays possible reasons for the device not being ready. See [Diagnostics Tab on page 36](#)

## **Alarms Tab**

The Alarms tab displays each configured alarm. The icon on the tab for the alarms page changes color to show the current active alarm status. A blinking alarm icon indicates that one or more alarms must be acknowledged or the device must be reset. See [Common Alarm Block \(P\\_Alarm\) on page 66](#) for more information.

## Run Time and Start Counter (P\_RunTime)


The P\_RunTime (Run Time and Start Counter) Add-On Instruction is used to accumulate the total run time and count of starts for a motor or other equipment. It is a software implementation of the mechanical hour meter that is often mounted in the door of a Motor Control Center (MCC) cabinet to show total motor run time. The run time and number of starts are variables used by maintenance personnel to determine when to perform maintenance activities on the motor or other equipment.

This document is for the visualization files, display elements, global objects, and HMI information. The operation of the Add-on Instructions and controller code is contained in publication [PROCES-RM013](#).

### Display Elements

A display element (global object) is created once and can be referenced multiple times on multiple displays in an application. When changes are made to the original (base) object, the instantiated copies (reference objects) are automatically updated. Use of global objects, with tag structures in the ControlLogix system, aid consistency and save engineering time.

**Table 285 - P\_RunTime Display Element**

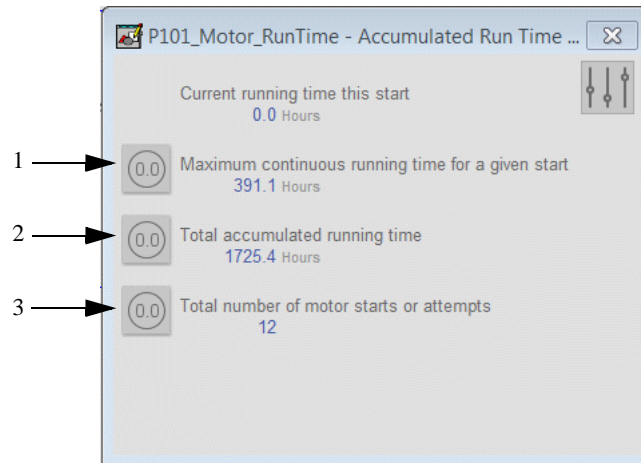
Display Element Name	Display Element	Description
GO_P_RunTime		Standard Run Time Global Object.

The graphic symbol in the preceding table is for use on faceplates and end-user process graphic displays.



## Operator Tab

The Faceplate initially opens to the Operator (Home) tab. From here, an operator can monitor the device status.



The following table lists the functions on the Operator tab.

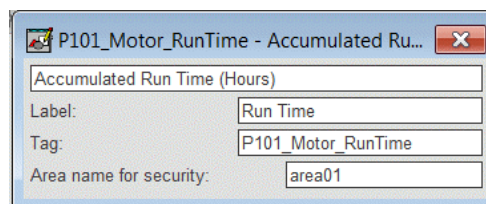
**Table 286 - P\_RunTime Operator Tab Description**

Item	Description
1	Click to clear maximum continuous running time for any given start.
2	Click to clear total running time.
3	Click to clear total number of motor starts or start attempts.

## Advanced Properties Display

### *HMI Configuration Tab*

The HMI configuration tab provides access to displayed text, and faceplate-to-faceplate navigation settings. Configure the description, label, tag, and security area for the device. See [Basic Faceplate Attributes on page 32](#) for the description of the common attributes.



## Restart Inhibit for Large Motor (P\_ResInh)

The P\_ResInh (Restart Inhibit for Large Motor) Add-On Instruction is used to help prevent damage to a large motor through repeated starts. The high starting current for a large motor causes considerable heating. The thermal mass of a large motor is much smaller relative to its horsepower and starting current compared to smaller motors. For this reason, repeated starts (or start attempts) over a short time overheats the motor windings, potentially damaging the motor permanently.


The P\_ResInh instruction provides a rule-based state model for restarts and is not intended to model or monitor the motor heating. It cannot replace sensor-based motor monitoring devices. It can, however, be a simple solution to avoid over stressing a motor without the cost (money or controller resources) of more extensive modeling and monitoring.

This document is for the visualization files, display elements, global objects, and HMI information. The operation of the Add-on Instructions and controller code is contained in publication [PROCES-RM013](#).

### Display Elements

A display element (global object) is created once and can be referenced multiple times on multiple displays in an application. When changes are made to the original (base) object, the instantiated copies (reference objects) are automatically updated. Use of global objects, with tag structures in the ControlLogix system, aid consistency and save engineering time.

**Table 287 - P\_ResInh Display Elements Description**

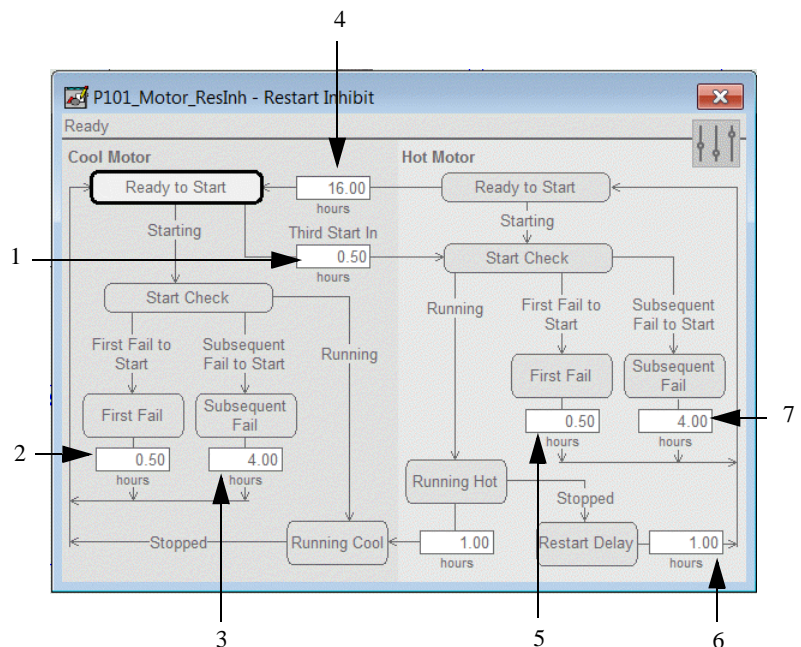
Display Element Name	Display Element	Description
GO_P_ResInh		Standard Restart Inhibit Global Object.

## Operator Tab

The Faceplate initially opens to the Operator (Home) tab. From here, an operator can monitor the device status.

The Operator tab shows the following information:

- A graphical representation of the P\_ResInh instruction State Diagram.
- Indication of the current state.
- The status appears at the top and displays either Ready to Start or Time Until Ready with an animated countdown timer.



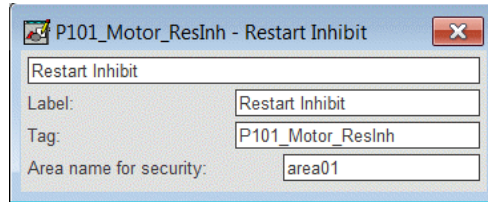
**Table 288 - Operator Tab Description**

Item	Description
1	Type the time, in hours, during which three motor starts turn a cold motor to hot.
2	Type the time, in hours, to wait after failing to start a cold motor the first time.
3	Type the time, in hours, to wait after failing to start a cold motor two or more times.
4	Type the time, in hours, for a stopped hot motor to cool.
5	Type the time, in hours, to wait after failing to start a hot motor the first time.
6	Type the time, in hours, to wait after stopping a running hot motor.
7	Type the time, in hours, to wait after failing to start a hot motor two or more times.

## Advanced Properties Display

### *HMI Configuration Tab*

The HMI configuration tab provides access to displayed text, and faceplate-to-faceplate navigation settings. Configure the description, label, tag, and security area for the device. See [Basic Faceplate Attributes on page 32](#) for the description of the common attributes.



**Notes:**



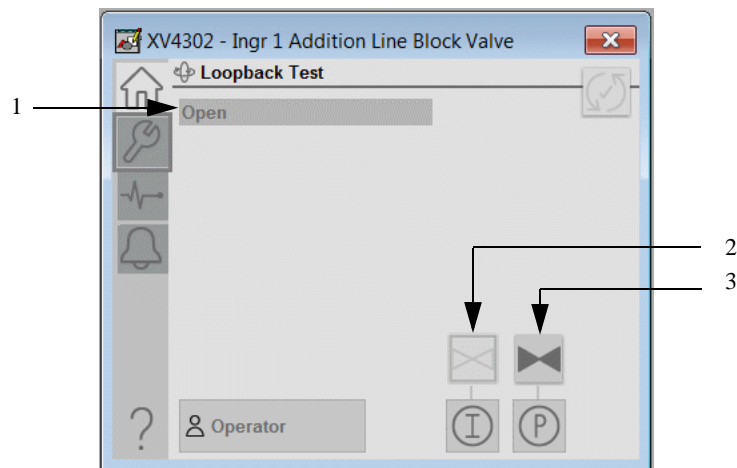
## Valves Family

The Process Objects in this group provide an interface to a wide range of process valve types and valve statistical calculations. This document is for the visualization files, display elements, global objects, and HMI information. The operation of the Add-on Instructions and controller code is contained in publication [PROCES-RM013](#).

### Common Valves Faceplates

Faceplate attributes are common to several Add-On Instructions in the valves family. Attributes specific to a valve are detailed in the individual sections. If a functionality is not enabled, the buttons are not visible. Common attributes for valves are detailed in this section. Basic attributes are described in the overview. See [Basic Faceplate Attributes on page 32](#)

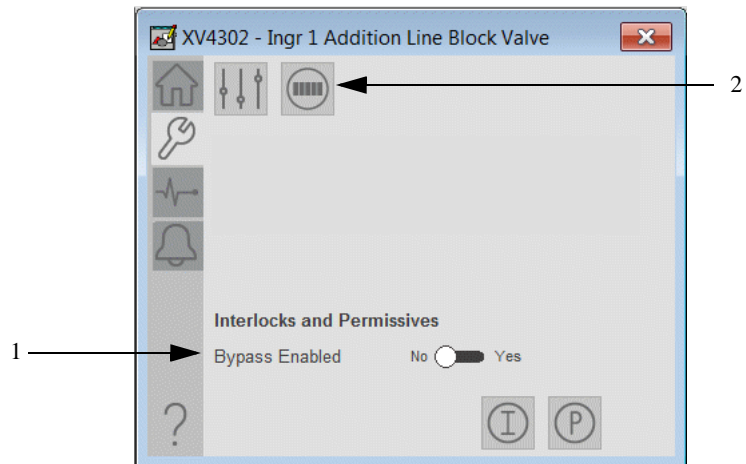
#### Common Operator Tab - Valves



**Table 289 - Common Operator Tab Attributes**

Item	Description
1	Valve state indicator.
2	Click to open valve.
3	Click to close valve.

*Common Maintenance Tab - Valves*



**Table 290 - Common Maintenance Tab Attributes**

Item	Description
1	Click yes to bypass checking of interlocks and permissives that can be bypassed.
2	Click to open Valve Statistics faceplate. See <a href="#">2-state Valve Statistics (P_ValveStats) on page 469</a>



## Analog/Pulsed Control Valve (P\_ValveC)





The P\_ValveC (Analog/Pulsed Control Valve) Add-On Instruction manipulates a control valve by using an analog signal or discrete signals, and monitors the valve by using an analog position feedback.

This document is for the visualization files, display elements, global objects, and HMI information. The operation of the Add-on Instructions and controller code is contained in publication [PROCES-RM013](#).

### Display Elements

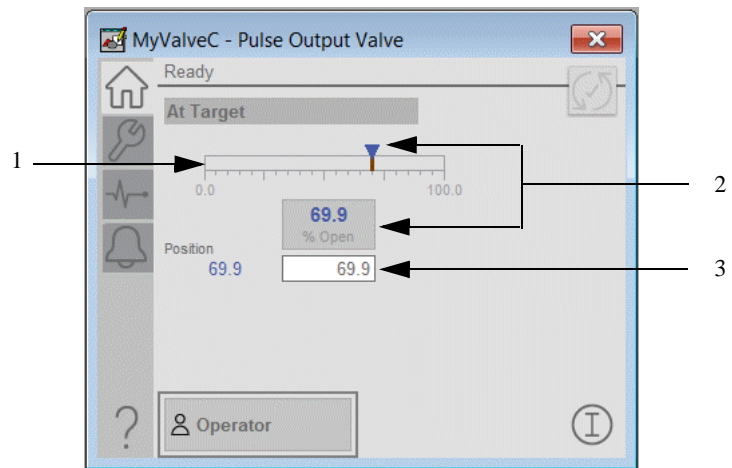
A display element (global object) is created once and can be referenced multiple times on multiple displays in an application. When changes are made to the original (base) object, the instantiated copies (reference objects) are automatically updated. Use of global objects, with tag structures in the ControlLogix® system, aid consistency and save engineering time.

**Table 291 - P\_ValveC Display Elements Description**

Display Element Name	Display Element	Description
GO_ProcessControlValve		Normal controlled valve symbol for horizontal pipe.
GO_ProcessControlValve1		Inverted controlled valve symbol for horizontal pipe.
GO_ProcessControlValve2		Controlled valve symbol for vertical pipe (pipe to the left).
GO_ProcessControlValve3		Controlled valve symbol for vertical pipe (pipe to the right).

## Operator Tab

The Faceplate initially opens to the Operator (Home) tab. From here, an operator can monitor the device status and manually operate the device when it is in Operator command source. Several features are common to all Add-On Instructions faceplates for the valves family. See [Common Valves Faceplates on page 411](#).



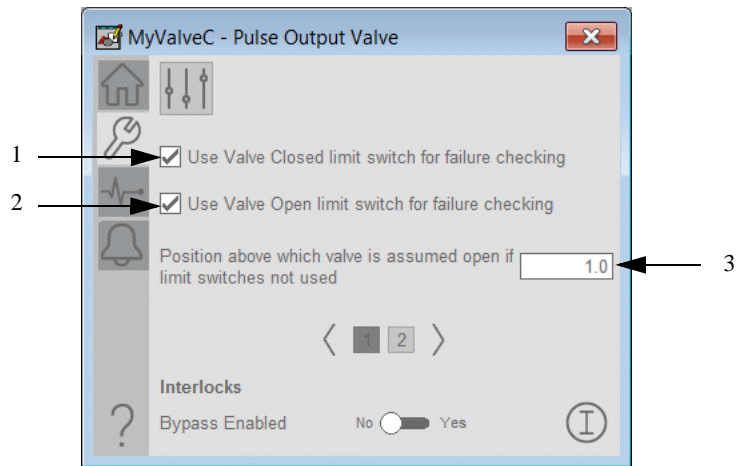
**Table 292 - Operator Tab Description**

Item	Description
1	Controlled Variable bar graph
2	Click to enter the Controlled Variable value.
3	Current Controlled Variable.

## Maintenance Tab

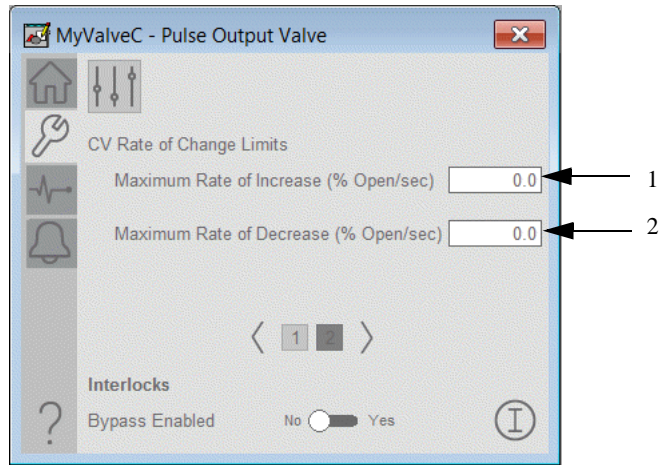
Maintenance personnel use the information and controls on the Maintenance tab to adjust device parameters, troubleshoot, temporarily work around device problems, and disable the device for routine maintenance. Several features are common to all Add-On Instructions faceplates for the valves family.

See [Common Valves Faceplates on page 411](#).



**Table 293 - Maintenance Tab Page 1 Description**

Item	Description
1	Check to enable the Valve Closed limit switch for failure checking.
2	Check to enable the Valve Open limit switch for failure checking.
3	Type a value to indicate the position, that if exceeded, the valve is assumed open if limit switches are not used.



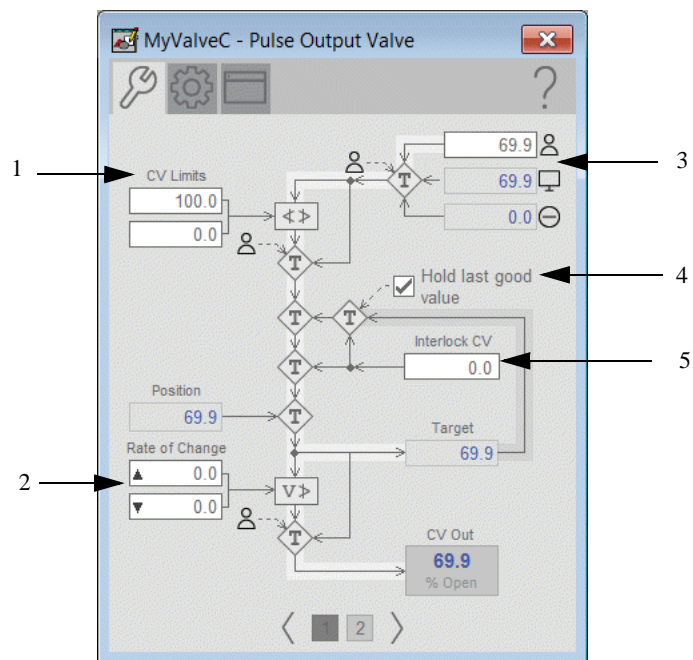
**Table 294 - Maintenance Tab Page 2 Description**

Item	Description
1	Maximum rate of increase (% Open/sec) for the CV rate of change limit. A value of zero indicates unlimited.
2	Maximum rate of decrease (% Open/sec) for the CV rate of change limit. A value of zero indicates unlimited.

## Advanced Properties Display

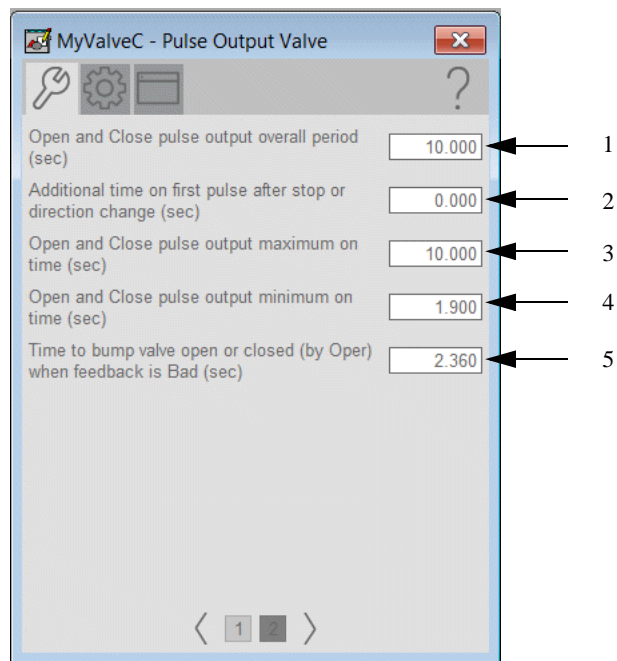
The Advanced Properties Display opens to the advanced maintenance settings. The Advanced Properties Display provides access to device configuration parameters and ranges, and options for device and I/O setup. This tab is used for initial system commissioning or later system changes.

### Advanced Maintenance Tab



**Table 295 - Advanced Maintenance Tab Page 1 Description**

Item	Description
1	Type the clamping limits for the Controlled Variable in engineering units. Clamping limits are enforced in Operator and Program command sources only.
2	Type the CV Rate of Change Limit in engineering units per second. This value determines the rate at which the CV output changes upon a change in CV target. A value of zero disables rate of change limiting.
3	Type the CV in engineering units. This entry is available in Operator command source and Maintenance command source. It is available in other command sources if Bumpless Program/Operator Transition is not selected.
4	When checked, the CV holds at the last good value when an Interlock trips or an I/O Fault occurs. When cleared, the CV is set to the configured Interlock CV value when an Interlock trips or an I/O Fault occurs.
5	Type the interlock target CV in engineering units. This value is used for the CV when interlocked or on an I/O Fault, but only if Hold Last Good Value is not selected.



**Table 296 - Advanced Maintenance Tab Page 2 Description**

Item	Description
1	Type a value to indicate the time (in seconds) for an open and close pulse.
2	Type a value to indicate the additional time (in seconds) on the first pulse after a stop or direction change.
3	Type a value to indicate the maximum pulse output time (in seconds) for opening and closing a value.
4	Type a value to indicate the minimum pulse output time (in seconds) for opening and closing a value.
5	Type a value to indicate the amount of time to bump the valve open or closed when feedback is bad.

## Engineering Tab

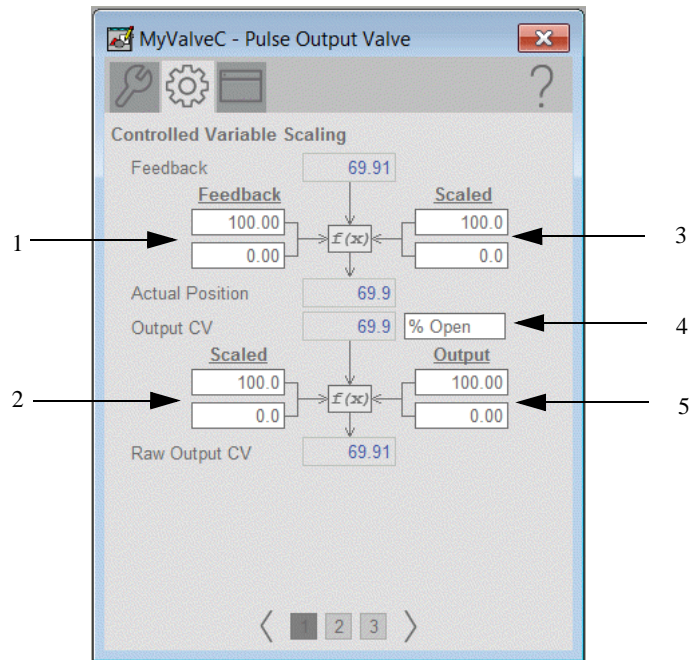
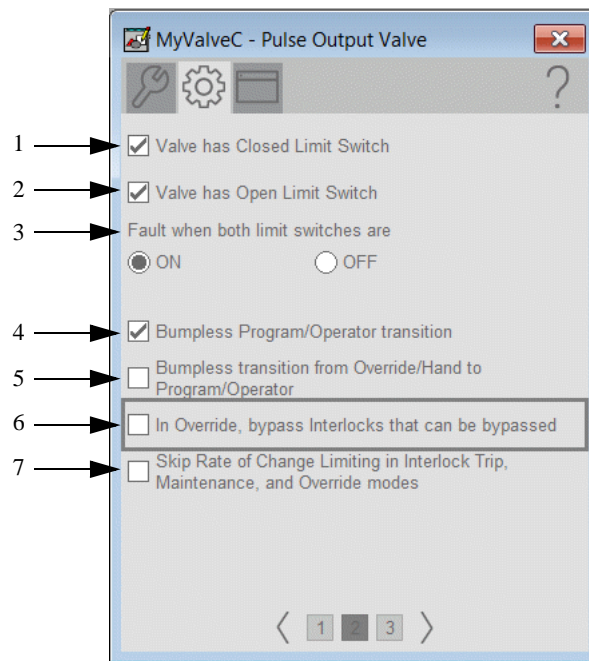


Table 297 - Engineering Tab Page 1 Description

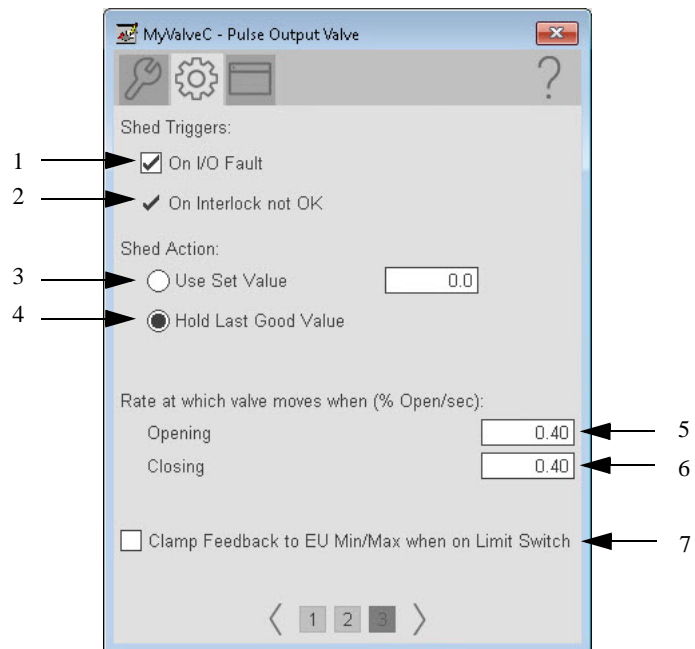
Item	Description
1	Type a maximum and minimum range for the raw feedback signal.
2	Type a maximum and minimum range for the controlled variable in engineering units (for scaling).
3	Type a maximum and minimum range for the controlled variable in engineering units (for scaling).
4	Type an engineering unit for the controlled variable.
5	Type maximum and minimum range (in raw units) to use for output unscaling to I/O.



**Table 298 - Engineering Tab Page 2 Description**

Item	Description
1	Check if the valve provides a closed limit switch signal.
2	Check if the valve provides an open limit switch signal.
3	Click to enable a fault when both limit switches are On, or when both switches are Off.
4	Check so that program settings track operator settings in Operator command source, and operator settings track program settings in Program command source for bumpless transfer.
5	Check so that program and operator settings of the CV track the output CV when the command source is Hand or Override.
6	Check so that bypassable interlocks and permissives are bypassed in Override command source.
7	Check to have the CV immediately go to its target value or configured Interlock CV value when an Interlock trips or the instruction is placed in Maintenance or Override command source. Clear the checkbox to have the CV always use rate of change limiting (ramping) of the CV output.



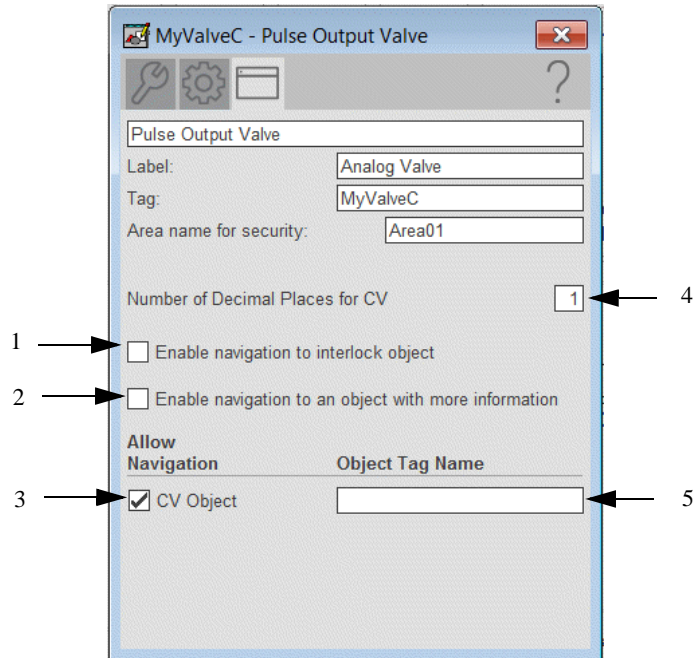


**Table 299 - Engineering Tab Page 3 Description**

Item	Description
1	Check to have the CV perform the configured Shed Action (hold or go to the Interlock CV value) when an I/O Fault occurs. When checked, the Shed Trigger is latched; that is, it is necessary to issue a Reset command to return to normal operation after the I/O Fault condition clears. Clear the checkbox to have an I/O Fault not trigger the configured Shed Action. The output continues to operate normally.
2	The device always performs the shed action on an Interlock not OK. This item cannot be unchecked. It is displayed as a reminder of the Interlock not OK function.
3	Click to have the output go to its configured Interlock CV value when an Interlock trips or an I/O Fault occurs (if configured as a shed trigger). Type a value for the interlock CV value to be used if shed is configured to go to a set value.
4	Click to have the output hold its current value when an Interlock trips or an I/O Fault occurs (if configured as shed trigger).
5	Type a value to indicate the rate that the valve moves when opening.
6	Type a value to indicate the rate that the valve moves when closing.
7	Check to clamp the feedback to the EU Min/Max when using Limit Switch.

### HMI Configuration Tab

The HMI configuration tab provides access to displayed text, and faceplate-to-faceplate navigation settings. Configure the description, label, tag, and security area for the device. See [Basic Faceplate Attributes on page 32](#) for the description of the common attributes.



**Table 300 - HMI Configuration Tab Description**

Item	Description
1	Check if an interlock instruction is used with this output. <b>IMPORTANT:</b> The name of the Interlock object in the controller must be the name of the object with the suffix ‘_Intlk’. For example, if your P_ValveC object has the name ‘ValveC123’, then its Interlock object must be named ‘ValveC123_Intlk’.
2	Check to enable navigation to an object with more information (Cfg_HasMoreObj is set to true.) This can be configured to navigate to an AOI backing tag or a UDT tag that has HMI_Type and HMI_Lib defined. For example, there is a motor with the tag name P_101 and there is a need to have the more information button navigate to the parent P_LLS object. A tag is created for the P_LLS object that is given the alias P101_More. When the more information button is pressed on the motor, it links to P101_More. This will open the faceplate for the LLS object.
3	Check to permit navigation to the faceplate of the object that is the source of the CV for this object.
4	Type the number of decimal places to be shown for the Control Variable.
5	Type the name of the CV object to navigate to when the CV display on the Home tab is clicked.

## **Diagnostics Tab**

The Diagnostic tab provides indications that are helpful to diagnose or help prevent device problems. The device problems can include specific reasons a device is 'Not Ready', device warnings and faults, warning and fault history, and predictive/preventive maintenance data.

The Diagnostics tab displays possible reasons for the device not being ready. See [Diagnostics Tab on page 36](#)

## **Alarms Tab**

The Alarms tab displays each configured alarm. The icon on the tab for the alarms page changes color to show the current active alarm status. A blinking alarm icon indicates that one or more alarms must be acknowledged or the device must be reset. See [Common Alarm Block \(P\\_Alarm\) on page 66](#) for more information.

## Hand-operated Valve (P\_ValveHO)

The P\_ValveHO (Hand-operated Valve) Add-On Instruction monitors a hand (locally) operated valve and displays its current state. The valve can have any type of actuator – handwheel, lever, motor, solenoid, pneumatic, hydraulic – but it is normally operated at the valve. The control system only monitors the valve via open and closed limit switches. The P\_ValveHO instruction cannot control the valve to both open and closed positions, but provides an optional Trip output to command the valve to its default (fail) position. If the trip function is used, the P\_ValveHO instruction checks to make sure that the valve reaches the configured trip position (open or closed) if a trip command is executed.

This document is for the visualization files, display elements, global objects, and HMI information. The operation of the Add-on Instructions and controller code is contained in publication [PROCES-RM013](#).

### Display Elements

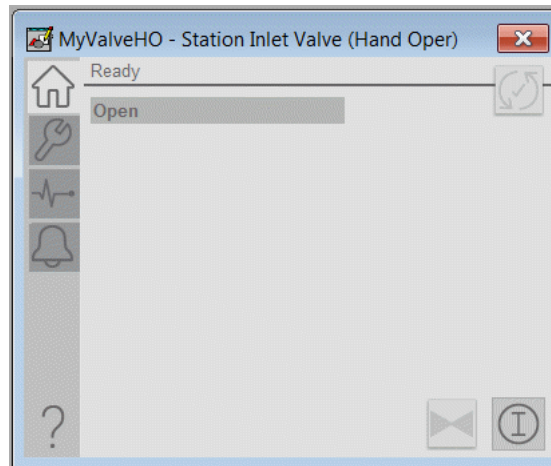
A display element (global object) is created once and can be referenced multiple times on multiple displays in an application. When changes are made to the original (base) object, the instantiated copies (reference objects) are automatically updated. Use of global objects, with tag structures in the ControlLogix system, aid consistency and save engineering time.

**Table 301 - P\_ValveHO Display Element Description**

Display Element Name	Display Element	Description
GO_P_ValveHO GO_P_ValveHO1 GO_P_ValveHO2 GO_P_ValveHO3		Hand-operated Valves that are shown in various orientations.

## Operator Tab

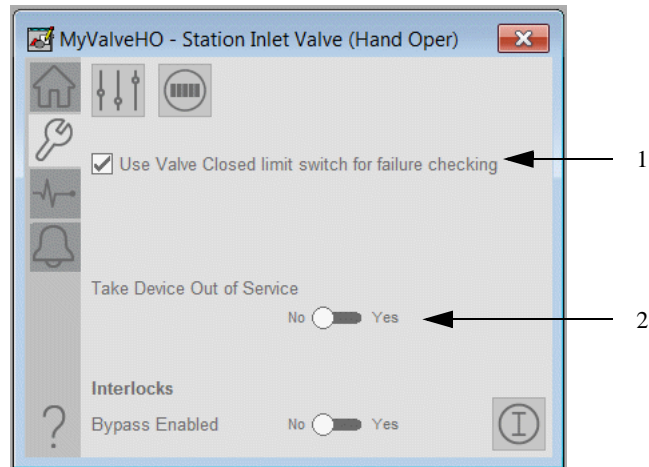
The Faceplate initially opens to the Operator (Home) tab. From here, an operator can monitor the device status and manually operate the device when it is in Operator command source. Several features are common to all Add-On Instructions faceplates for the valves family. See [Common Valves Faceplates on page 411](#).



## Maintenance Tab

Maintenance personnel use the information and controls on the Maintenance tab to adjust device parameters, troubleshoot, temporarily work around device problems, and disable the device for routine maintenance. Several features are common to all Add-On Instructions faceplates for the valves family.

See [Common Valves Faceplates on page 411](#).



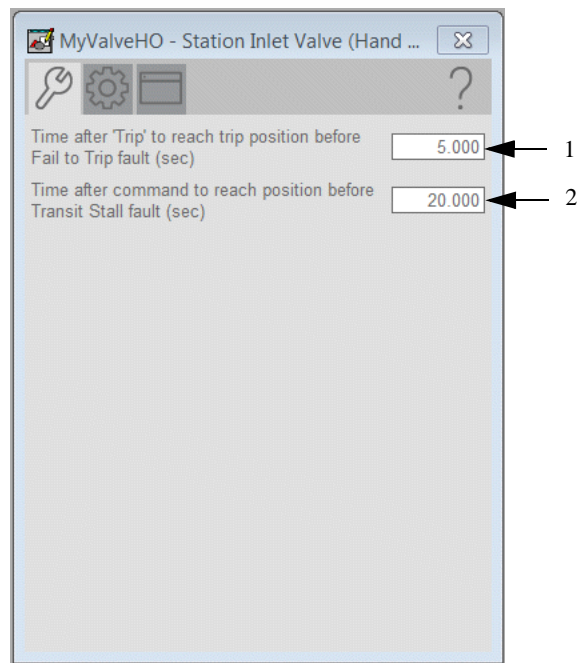
**Table 302 - Maintenance Tab Description**

Item	Description
1	Check to configure the valve to use the closed limit switch. Clear the checkbox to bypass the closed limit switch temporarily.
2	Click to take the device out of service.

## Advanced Properties Display

The Advanced Properties Display opens to the advanced maintenance settings. The Advanced Properties Display provides access to device configuration parameters and ranges, and options for device and I/O setup. This tab is used for initial system commissioning or later system changes.

### *Advanced Maintenance Tab*

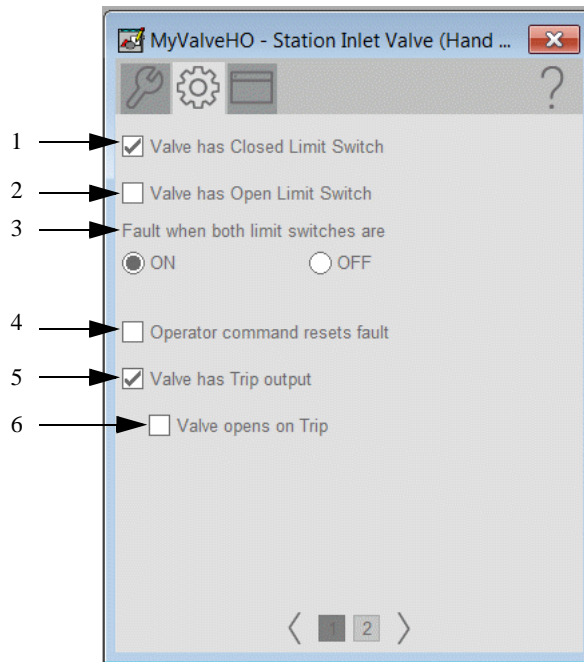


**Table 303 - Advanced Maintenance Tab Description**

Item	Description
1	Type the amount of time to allow the valve to reach its trip position after a trip command is received before raising a trip fail alarm.
2	Type the amount of time (in seconds) that the valve is not confirmed open or closed before a Transit Stall.

### Engineering Tab

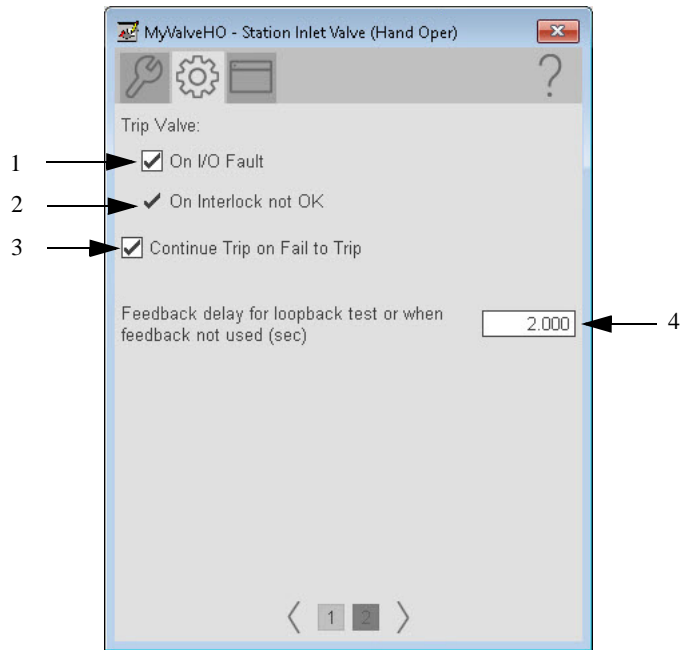
The Engineering tab consists of two pages.



**Table 304 - Engineering Tab Page 1 Description**

Item	Description
1	Check if the valve has a closed limit switch and the switch is wired to Inp_ClosedLS for position monitoring.
2	Check if the valve has an open limit switch and the switch is wired to Inp_OpenLS for position monitoring.
3	Click 'ON' if both limit switches are OFF when the valve is moving in normal operation. Click 'OFF' if both limit switches are ON when the valve is moving in normal operation. This selection determines which limit switch combination indicates abnormal operation.
4	Check to allow the operator trip command to reset any previous faults (I/O fault, fail to trip, interlock trip), then trip the valve. Clear this checkbox to reset faults with only the reset command.
5	Check if a trip output is connected to the P_ValveHO instruction to trip the valve on an interlock or trip command. This check makes the trip command button visible on the operator tab.
6	Check if sending the trip output to the valve causes it to open (fail open valve). Clear this checkbox if sending the Trip output to the valve causes it to close (fail closed valve).



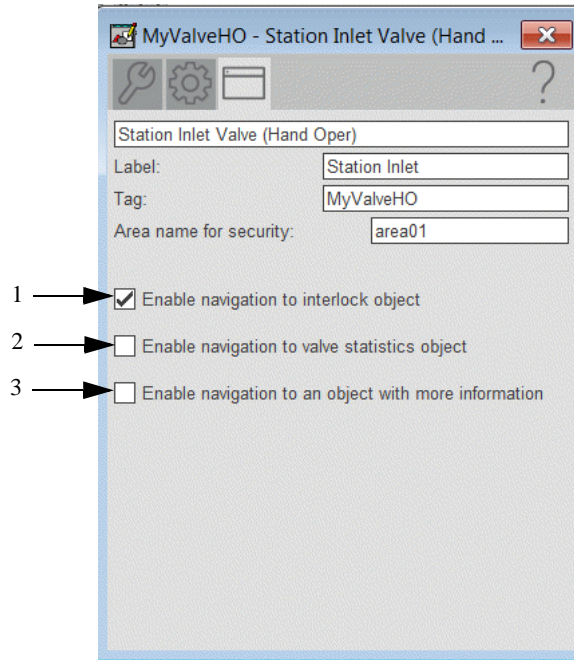


**Table 305 - Engineering Tab Page 2 Description**

Item	Description
1	Check to send the trip output to the valve if an I/O Fault is detected. Clear this checkbox to show only the I/O fault status/alarm and not trip the valve if an I/O fault is detected.
2	The valve always trips on an interlock not OK. This item cannot be unchecked. It is displayed as a reminder that the interlock not OK function always trips the valve.
3	Check to keep sending the trip output to the valve on a trip, even if position feedback does not confirm the valve reached the trip position. Clear this checkbox to stop sending the trip output to the valve when the valve trip times out and the fail to trip status is set.
4	Configure the amount of time the valve status shows 'tripping' before showing an opened or closed status when the valve is tripped and I/O are being simulated (Inp_Sim = 1).

### HMI Configuration Tab

The HMI configuration tab provides access to displayed text, and faceplate-to-faceplate navigation settings. Configure the description, label, tag, and security area for the device. See [Basic Faceplate Attributes on page 32](#) for the description of the common attributes.



**Table 306 - HMI Configuration Tab Description**

Item	Description
1	<p>Check if an interlock object is connected to Inp_Intlk. This check changes the interlock indicator on the operator tab to a button that opens the interlocks faceplate.</p> <p><b>IMPORTANT:</b> The name of the Interlock object in the controller must be the name of the object with the suffix ‘_Intlk’. For example, if your P_ValveHO object has the name ‘ValveHO123’, then its Interlock object must be named ‘ValveHO123_Intlk’.</p>
2	<p>Check if a Valve Stats instruction is used with this valve. This check makes the Valve Statistics button visible; clicking this button opens the valve statistics faceplate for this valve.</p> <p><b>IMPORTANT:</b> The name of the Valve Stats object in the controller must be the name of the object with the suffix ‘_ValveStats’. For example, if your P_ValveHO object has the name ‘ValveHO123’, then its Valve Stats object must be named ‘ValveHO123_ValveStats’.</p>
3	<p>Check to enable navigation to an object with more information (Cfg_HasMoreObj is set to true.)</p> <p>This can be configured to navigate to an AOI backing tag or a UDT tag that has HMI_Type and HMI_Lib defined.</p> <p>For example, there is a motor with the tag name P_101 and there is a need to have the more information button navigate to the parent P_LLS object. A tag is created for the P_LLS object that is given the alias P101_More. When the more information button is pressed on the motor, it links to P101_More. This will open the faceplate for the LLS object.</p>

## **Diagnostics Tab**

The Diagnostic tab provides indications that are helpful to diagnose or help prevent device problems. The device problems can include specific reasons a device is 'Not Ready', device warnings and faults, warning and fault history, and predictive/preventive maintenance data.

The Diagnostics tab displays possible reasons for the device not being ready. See [Diagnostics Tab on page 36](#)

## **Alarms Tab**

The Alarms tab displays each configured alarm. The icon on the tab for the alarms page changes color to show the current active alarm status. A blinking alarm icon indicates that one or more alarms must be acknowledged or the device must be reset. See [Common Alarm Block \(P\\_Alarm\) on page 66](#) for more information.

## Motor-operated Valve (P\_ValveMO)

The P\_ValveMO (Motor-operated Valve) Add-On Instruction is used to operate (open and close) a motor-operated valve in various command sources, monitoring for fault conditions.

This document is for the visualization files, display elements, global objects, and HMI information. The operation of the Add-on Instructions and controller code is contained in publication [PROCES-RM013](#).

### Display Elements

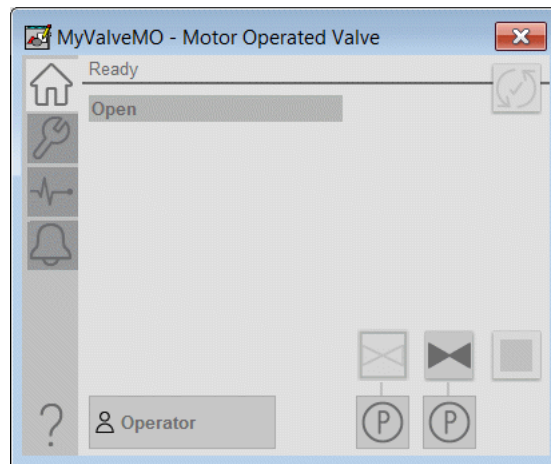
A display element (global object) is created once and can be referenced multiple times on multiple displays in an application. When changes are made to the original (base) object, the instantiated copies (reference objects) are automatically updated. Use of global objects, with tag structures in the ControlLogix system, aid consistency and save engineering time.

**Table 307 - P\_ValveMO Display Elements Description**

Display Element Name	Display Element	Description
GO_P_ValveMO GO_P_ValveMO1 GO_P_ValveMO2 GO_P_ValveMO3		Standard motor-operated valve global objects.

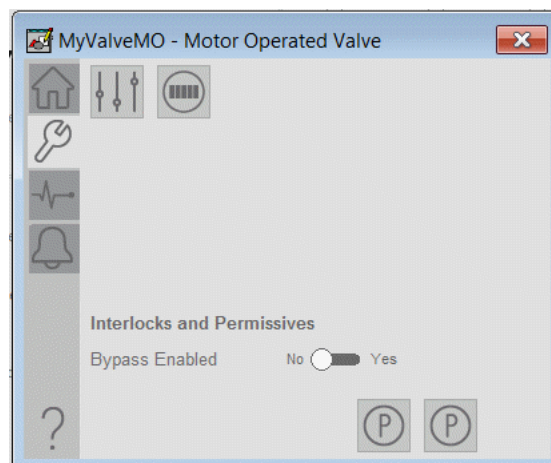
## Operator Tab

The Faceplate initially opens to the Operator (Home) tab. From here, an operator can monitor the device status and manually operate the device when it is in Operator command source. Several features are common to all Add-On Instructions faceplates for the valves family. See [Common Valves Faceplates on page 411](#).



## Maintenance Tab

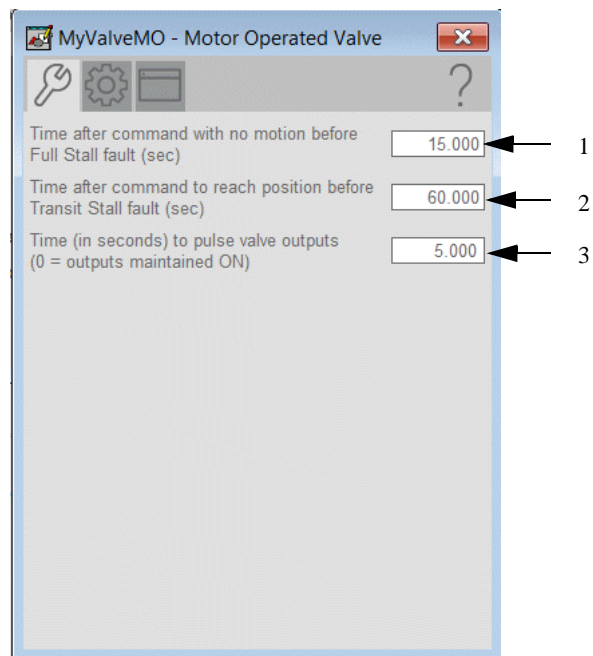
Maintenance personnel use the information and controls on the Maintenance tab to adjust device parameters, troubleshoot, temporarily work around device problems, and disable the device for routine maintenance. Several features are common to all Add-On Instructions faceplates for the valves family. See [Common Valves Faceplates on page 411](#).



## Advanced Properties Display

The Advanced Properties Display opens to the advanced maintenance settings. The Advanced Properties Display provides access to device configuration parameters and ranges, and options for device and I/O setup. This tab is used for initial system commissioning or later system changes.

### Advanced Maintenance Tab



**Table 308 - Advanced Maintenance Tab Description**

Item	Description
1	Type the amount of time (in seconds) with no motion after a command for an alarm to occur.
2	Type the amount of time (in seconds) to reach position after a command before an alarm occurs.
3	Type the amount of time (in seconds) to pulse the valve outputs. 0 means that the outputs are always on.

## Engineering Tab

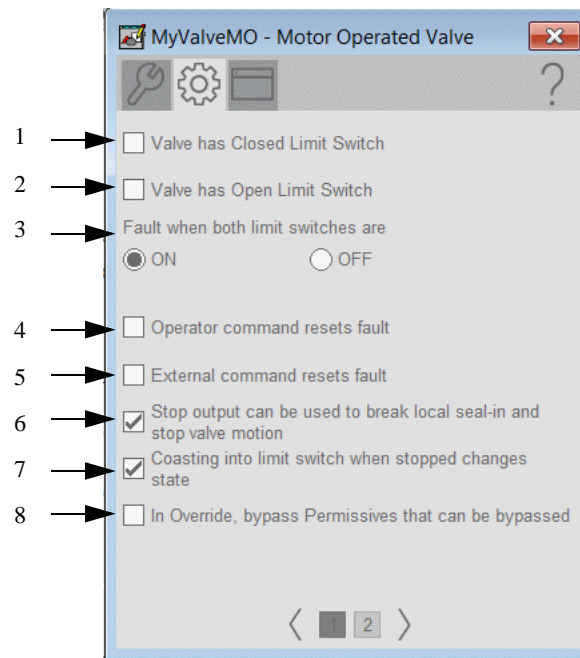
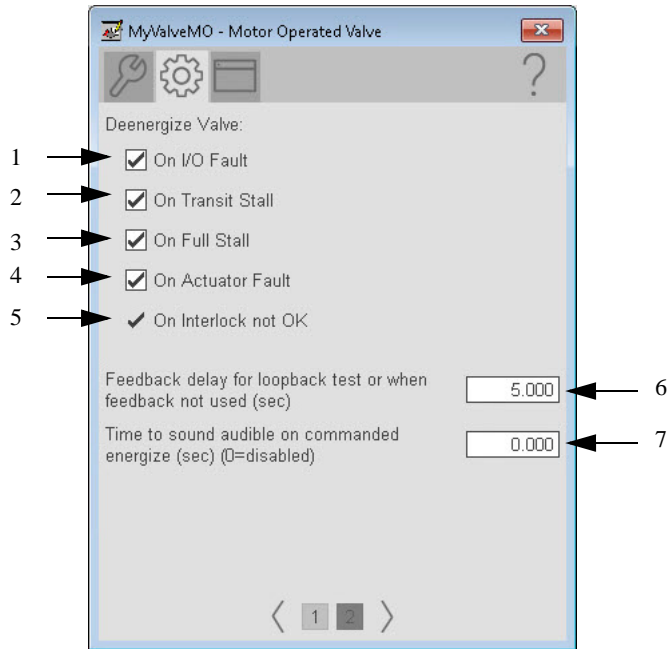


Table 309 - Engineering Tab Page 1 Description

Item	Description
1	Check if the valve has a closed limit switch and the switch is wired to Inp_ClosedLS for position monitoring.
2	Check if the valve has an open limit switch and the switch is wired to Inp_OpenLS for position monitoring.
3	Click 'ON' if both limit switches are off when the valve is moving in normal operation. Click 'OFF' if both limit switches are on when the valve is moving in normal operation. This selection determines which limit switch combination indicates abnormal operation.
4	Check to allow operator commands to reset any previous faults (I/O fault, transit stall, full stall, interlock trip), then move the valve. Clear this checkbox to reset faults by using only the reset command.
5	Check to allow External commands to reset any previous faults (I/O fault, transit stall, full stall, interlock trip), then move the valve. Clear this checkbox to reset faults by using only the reset command.
6	Check if a signal used to stop valve motion is connected to the Out_Stop output of the instruction. This action makes the Stop command button visible on the Operator tab.
7	Check to allow the state to change when coasting into the limit switch. Clear this checkbox keep the state when coasting into the limit switch.
8	Check to bypass permissives that can be bypassed in Override command source.



**Table 310 - Engineering Tab Page 2 Description**

Item	Description
1	<p>Check to send a stop output to the valve and clear the Open and Close outputs when an I/O Fault condition occurs.</p> <p>Clear this checkbox to keep the outputs to the valve in their current state on an I/O Fault condition.</p> <p><b>IMPORTANT:</b> When this checkbox is checked and an I/O Fault condition occurs, a reset is required before the valve can be energized.</p>
2	<p>Check to send a stop output to the valve and clear the Open and Close outputs when a Transit Stall condition occurs.</p> <p>Clear this checkbox to keep the outputs to the valve in their current state (keep trying) on a Transit Stall condition. (A Transit Stall means the valve, when commanded to move, moved off its original position, but did not reach its commanded position before the Transit Stall time expired.)</p> <p><b>IMPORTANT:</b> When this checkbox is checked and a Transit Stall condition occurs, a reset is required before the valve can be energized.</p>
3	<p>Check to send a stop output to the valve and clear the Open and Close outputs when a Full Stall condition occurs.</p> <p>Clear this checkbox to keep the outputs to the valve in their current state (keep trying) on a Full Stall condition. (A Full Stall means the valve, when commanded to move, did not move off its original position before the Full Stall time expired.)</p> <p><b>IMPORTANT:</b> When this checkbox is checked and a Full Stall condition occurs, a reset is required before the valve can be energized.</p>
4	<p>Check to send a stop output to the valve and clear the Open and Close outputs when an Actuator Fault condition occurs.</p> <p>Clear this checkbox to keep the outputs to the valve in their current state on an Actuator Fault condition.</p> <p><b>IMPORTANT:</b> When this checkbox is checked and an Actuator Fault condition occurs, a reset is required before the valve can be energized.</p>



Item	Description
5	The device always de-energizes on an interlock not OK. This item cannot be unchecked. It is displayed as a reminder that the interlock not OK function always causes the valve to de-energize.
6	Type the time delay (in seconds) for the opened or closed status to be echoed back when Simulation is enabled or when limit switch feedback is not used.
7	Type the seconds to sound an audible alarm when the valve energizes.

### *HMI Configuration Tab*

The HMI configuration tab provides access to displayed text, and faceplate-to-faceplate navigation settings. Configure the description, label, tag, and security area for the device. See [Basic Faceplate Attributes on page 32](#) for the description of the common attributes.

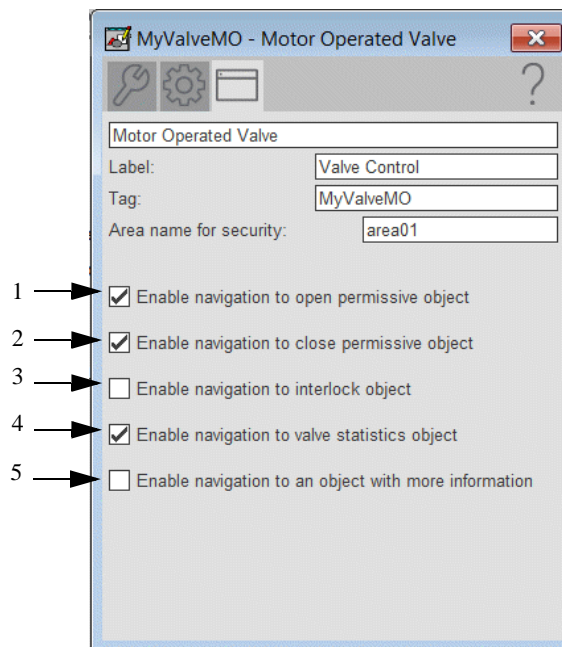


Table 311 - HMI Configuration Tab Description

Item	Description
1	<p>Check if you have a P_Perm instruction that is used with this valve for Open Permissives. This action changes the Permissive indicator to a clickable button to open the Permissive faceplate.</p> <p><b>IMPORTANT:</b> The name of the Permissive object in the controller must be the name of the object with the suffix ‘_OpenPerm’. For example, if your P_ValveMO object has the name ‘ValveMO123’, then its Permissive object must be named ‘ValveMO123_OpenPerm’.</p>
2	<p>Check if you have a P_Perm instruction that is used with this valve for Close Permissives. This action changes the Permissive indicator to a clickable button to open the Permissive faceplate.</p> <p><b>IMPORTANT:</b> The name of the Permissive object in the controller must be the name of the object with the suffix ‘_ClosePerm’. For example, if your P_ValveMO object has the name ‘ValveMO123’, then its Permissive object must be named ‘ValveMO123_ClosePerm’.</p>
3	<p>Check if an interlock instruction is used with this output.</p> <p><b>IMPORTANT:</b> The name of the Interlock object in the controller must be the name of the object with the suffix ‘_Intlk’. For example, if your P_ValveMO object has the name ‘ValveMO123’, then its Interlock object must be named ‘ValveMO123_Intlk’.</p>
4	<p>Check if a Valve Stats object is used with this valve. This action makes the Valve Statistics button visible; click this button to open the Valve Statistics faceplate for this valve.</p> <p><b>IMPORTANT:</b> The name of the ValveStats object in the controller must be the name of the object with the suffix ‘_ValveStats’. For example, if your P_ValveMO object has the name ‘ValveMO123’, then its Valve Stats object must be named ‘ValveMO123_ValveStats’.</p>
5	<p>Check to enable navigation to an object with more information (Cfg_HasMoreObj is set to true.)</p> <p>This can be configured to navigate to an AOI backing tag or a UDT tag that has HMI_Type and HMI_Lib defined.</p> <p>For example, there is a motor with the tag name P_101 and there is a need to have the more information button navigate to the parent P_LLS object. A tag is created for the P_LLS object that is given the alias P101_More. When the more information button is pressed on the motor, it links to P101_More. This will open the faceplate for the LLS object.</p>

## **Diagnostics Tab**

The Diagnostic tab provides indications that are helpful to diagnose or help prevent device problems. The device problems can include specific reasons a device is 'Not Ready', device warnings and faults, warning and fault history, and predictive/preventive maintenance data.

The Diagnostics tab displays possible reasons for the device not being ready. See [Diagnostics Tab on page 36](#)

## **Alarms Tab**

The Alarms tab displays each configured alarm. The icon on the tab for the alarms page changes color to show the current active alarm status. A blinking alarm icon indicates that one or more alarms must be acknowledged or the device must be reset. See [Common Alarm Block \(P\\_Alarm\) on page 66](#) for more information.

## Mix-proof Valve (P\_ValveMP)

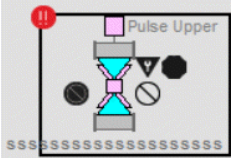
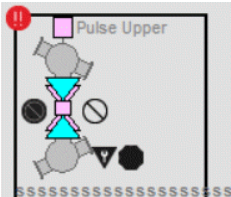
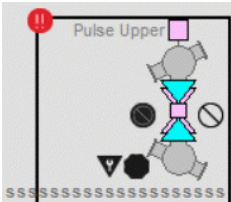
The Mix-proof Valve (P\_ValveMP) Add-On Instruction controls one mix-proof valve in various command sources and states. This valve can also check position feedback inputs to verify that the valve reached the commanded position. An alarm can be provided on failure to reach a target position.

This document is for the visualization files, display elements, global objects, and HMI information. The operation of the Add-on Instructions and controller code is contained in publication [PROCES-RM013](#).

### Display Elements

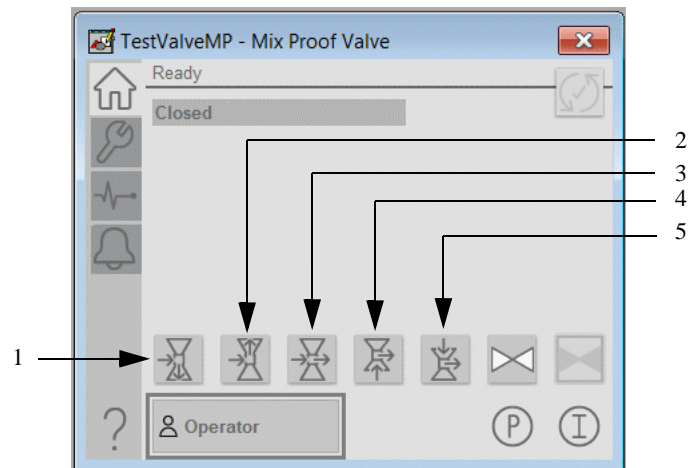
A display element (global object) is created once and can be referenced multiple times on multiple displays in an application. When changes are made to the original (base) object, the instantiated copies (reference objects) are automatically updated. Use of global objects, with tag structures in the ControlLogix system, aid consistency and save engineering time.

**Table 312 - P\_ValveMP Display Element Description**

Display Element Name	Display Element	Description
GO_P_ValveMP2D		This Mix-proof Valve graphic object allows for numerous orientations on displays.
GO_P_ValveMP_Orth		This 3-D orthogonal Mix-proof Valve graphic object provides different valve angle positions on displays.
GO_P_ValveMP_Orth1		This 3-D orthogonal Mix-proof Valve graphic object provides different valve angle positions on displays.

## Operator Tab

The Faceplate initially opens to the Operator (Home) tab. From here, an operator can monitor the device status and manually operate the device when it is in Operator command source. Several features are common to all Add-On Instructions faceplates for the valves family. See [Common Valves Faceplates on page 411](#).



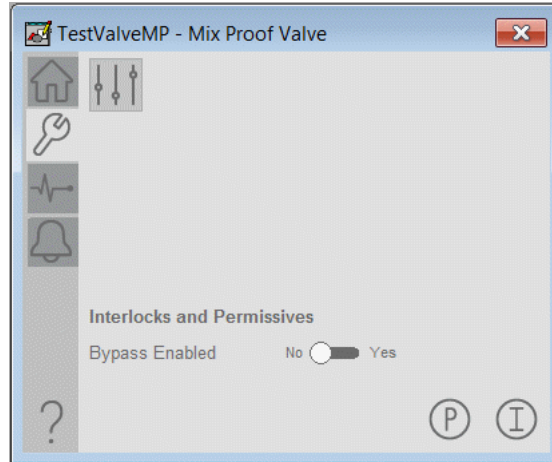
**Table 313 - Operator Tab Description**

Item	Description
1	Click to go to the CIP/SIP Valve Lower Seat state.
2	Click to go to the CIP/SIP Valve Upper Seat state.
3	Click to go to the CIP/SIP Valve Cavity state.
4	Click to go to the Lift Valve Lower Seat state.
5	Click to go to the Lift Valve Upper Seat state.

## Maintenance Tab

Maintenance personnel use the information and controls on the Maintenance tab to adjust device parameters, troubleshoot, temporarily work around device problems, and disable the device for routine maintenance. Several features are common to all Add-On Instructions faceplates for the valves family.

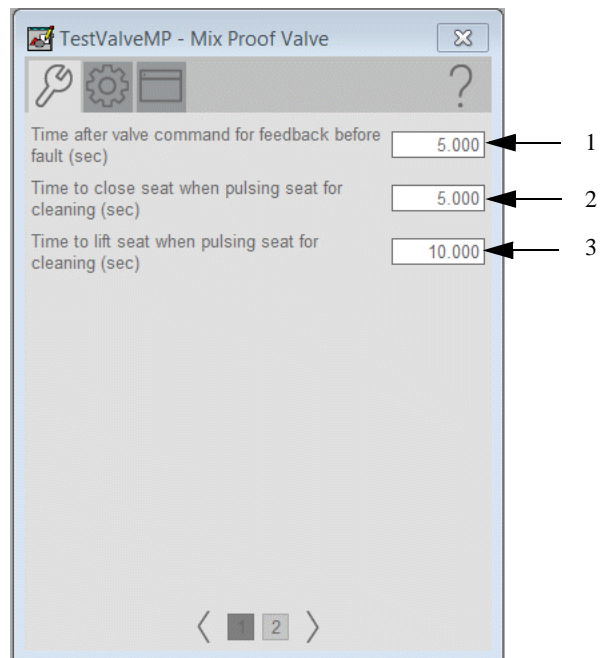
See [Common Valves Faceplates on page 411](#).



## Advanced Properties Display

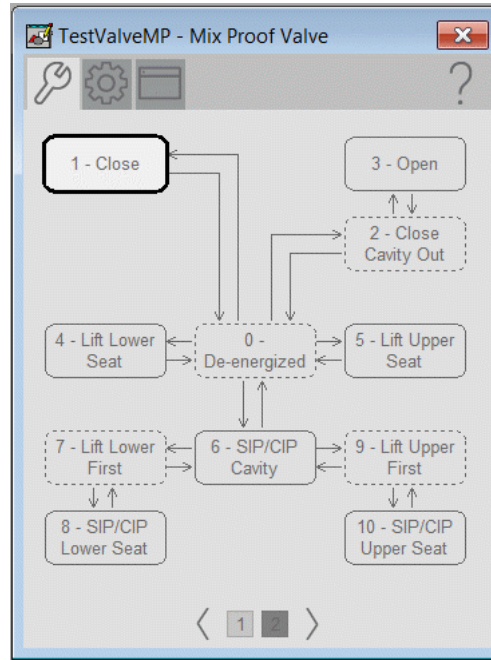
The Advanced Properties Display opens to the advanced maintenance settings. The Advanced Properties Display provides access to device configuration parameters and ranges, and options for device and I/O setup. This tab is used for initial system commissioning or later system changes.

### Advanced Maintenance Tab



**Table 314 - Advanced Maintenance Tab Page 1 Description**

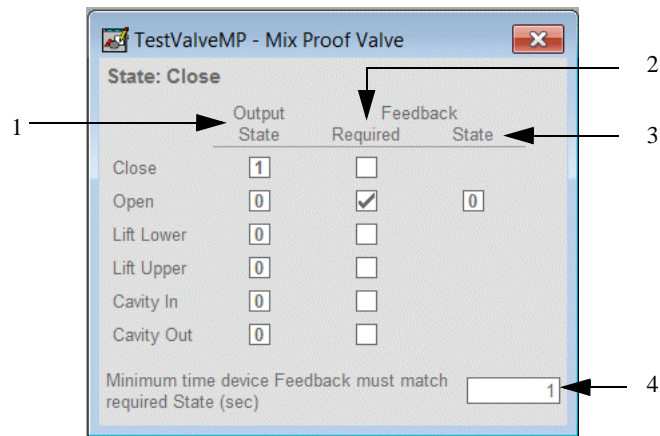
Item	Description
1	Type a value (seconds) that gives the valve time to achieve state before triggering a valve failure fault.
2	Type a value (seconds) that the valve seat is held closed when pulsing for cleaning.
3	Type a value (seconds) that the valve seat is held open when pulsing for cleaning.



**Table 315 - Advanced Maintenance Tab Page 2 Description**

Item	Description
1	Click a state box to open the State Configuration display to access configuration parameters for the valve state

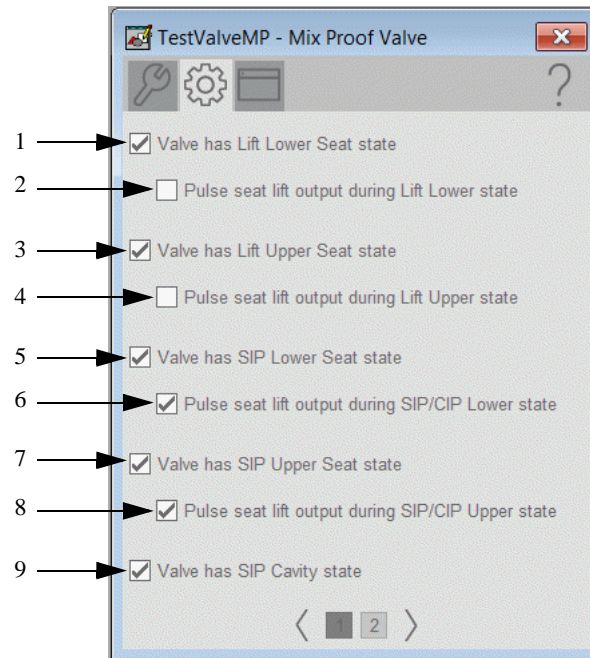
*State Configuration Display*



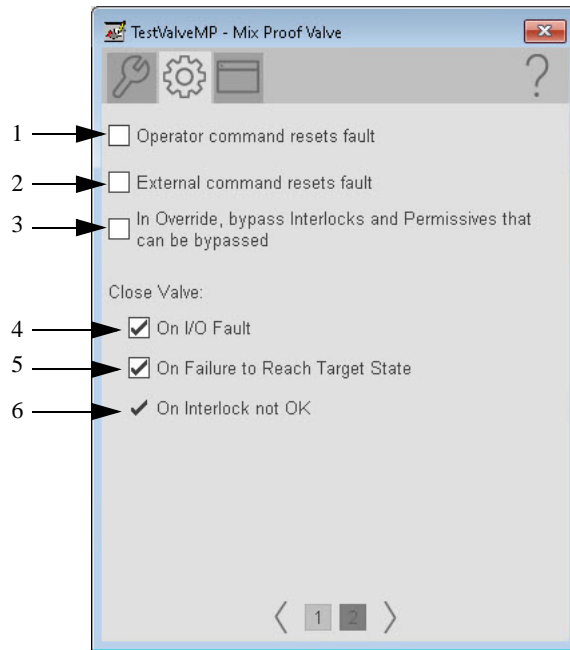
**Table 316 - State Configuration Display Description**

Item	Description
1	Set State of each Output in the selected valve state.
2	Check to require a feedback signals for the selected valve state.
3	Sets the desired value of the feedback signals for the selected valve state.
4	Type a value (seconds) the feedback must match for the valve to achieve the selected state.



*Engineering Tab***Table 317 - Engineering Tab Page 1 Description**

Item	Description
1	Check to enable the lift lower seat state for the valve.
2	Check to enable pulsing in the lift lower state.
3	Check to enable the lift upper seat state for the valve.
4	Check to enable pulsing in the lift upper state.
5	Check to enable the SIP lower seat state for the valve.
6	Check to enable pulsing in the SIP/CIP lower state.
7	Check to enable the SIP upper seat state for the valve.
8	Check to enable pulsing in the SIP/CIP upper state.
9	Check to enable the SIP cavity state for the valve.

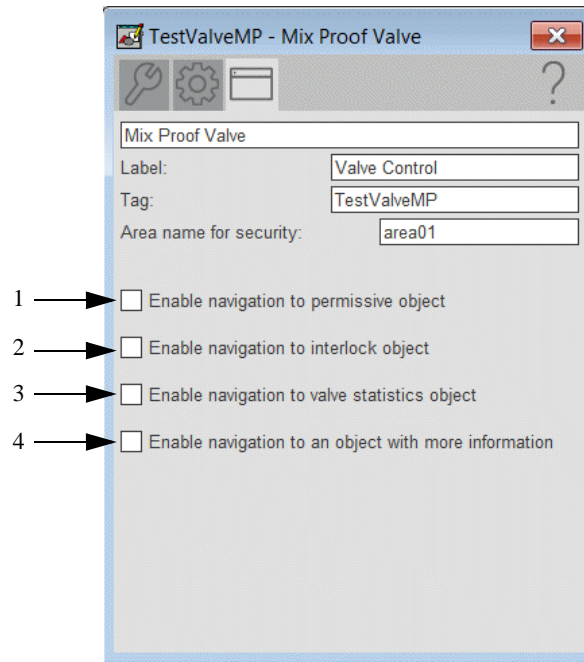


**Table 318 - Engineering Tab Page 2 Description**

Item	Description
1	Check to reset a fault on a new Operator command.
2	Check to reset a fault on a new External command.
3	Check to bypass permissives and interlocks in Override command source.
4	Check to close the valve when an I/O Fault occurs. A reset is required to clear this latched shed condition. Clear this checkbox to show only the I/O fault status/alarm and not trip the valve if an I/O fault is detected.
5	Check to close the valve when a Position Fail occurs. A reset is required to clear this latched shed condition. Clear this checkbox to show only the Position Fail status/alarm and not trip the valve if a Position Fail is detected.
6	The device always sheds (closes) on an interlock not OK. This item cannot be unchecked. It is displayed as a reminder that the interlock not OK function always triggers a shed.

### HMI Configuration Tab

The HMI configuration tab provides access to displayed text, and faceplate-to-faceplate navigation settings. Configure the description, label, tag, and security area for the device. See [Basic Faceplate Attributes on page 32](#) for the description of the common attributes.



**Table 319 - HMI Configuration Tab Description**

Item	Description
1	Check if a Permissive object is used with this valve. This check changes the Permissive indicator to a clickable button to open the Permissive faceplate. <b>IMPORTANT:</b> The name of the Permissive object in the controller must be the name of the object with the suffix '_Perm'. For example, if your P_ValveMP object has the name 'ValveMP123', then its Permissive object must be named 'ValveMP123_Perm'.

Item	Description
2	<p>Check if an Interlock object is used with this valve. This check changes the Interlock indicator to a clickable button to open the Interlock faceplate.</p> <p><b>IMPORTANT:</b> The name of the interlock object in the controller must be the name of the object with the suffix ‘_Intlk’. For example, if your P_ValveMP object has the name ‘ValveMP123’, then its interlock object must be named ‘ValveMP123_Intlk’.</p>
3	<p>Check if the Valve Stats instruction (for example, P_ValveStats) is used with this device. This check adds a button to the faceplate that opens the Valve Stats faceplate.</p> <p><b>IMPORTANT:</b> The name of the Valve Statistics object in the controller must be the name of the object with the suffix ‘_ValveStats’. For example, if your P_ValveMP object has the name ‘ValveMP123’, then its Interlock object must be named ‘ValveMP123_ValveStats’.</p>
4	<p>Check to enable navigation to an object with more information (Cfg_HasMoreObj is set to true.)</p> <p>This can be configured to navigate to an AOI backing tag or a UDT tag that has HMI_Type and HMI_Lib defined.</p> <p>For example, there is a motor with the tag name P_101 and there is a need to have the more information button navigate to the parent P_LLS object. A tag is created for the P_LLS object that is given the alias P101_More. When the more information button is pressed on the motor, it links to P101_More. This will open the faceplate for the LLS object.</p>

## **Diagnostics Tab**

The Diagnostic tab provides indications that are helpful to diagnose or help prevent device problems. The device problems can include specific reasons a device is 'Not Ready', device warnings and faults, warning and fault history, and predictive/preventive maintenance data.

The Diagnostics tab displays possible reasons for the device not being ready. See [Diagnostics Tab on page 36](#)

## **Alarms Tab**

The Alarms tab displays each configured alarm. The icon on the tab for the alarms page changes color to show the current active alarm status. A blinking alarm icon indicates that one or more alarms must be acknowledged or the device must be reset. See [Common Alarm Block \(P\\_Alarm\) on page 66](#) for more information.

## Advanced Mix-proof Valve (P\_ValveMPAdv)

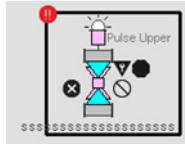
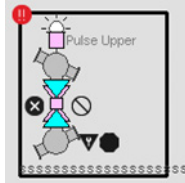
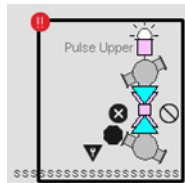
The Advanced Mix-proof Valve (P\_ValveMPAdv) Add-On Instruction controls one mix-proof valve in various command sources and states. This instruction can also check valve position feedback inputs to verify that the valve reached the commanded position. An alarm can be provided on failure to reach a target position.

This document is for the visualization files, display elements, global objects, and HMI information. The operation of the Add-on Instructions and controller code is contained in publication [PROCES-RM013](#).

### Display Elements

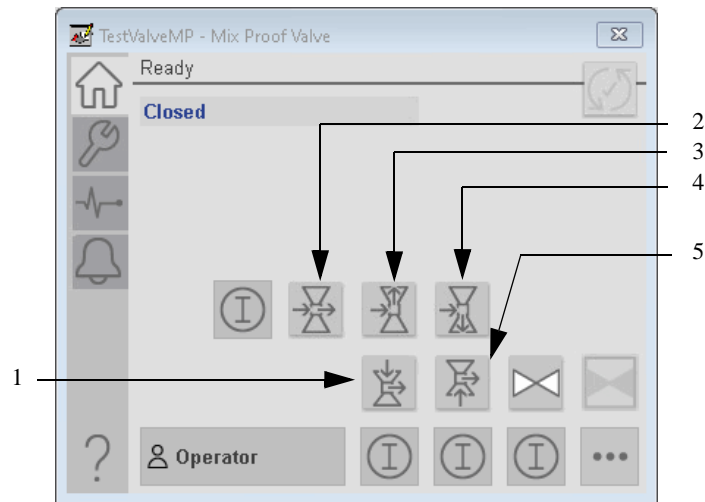
A display element (global object) is created once and can be referenced multiple times on multiple displays in an application. When changes are made to the original (base) object, the instantiated copies (reference objects) are automatically updated. Use of global objects, with tag structures in the ControlLogix system, aid consistency and save engineering time.

**Table 320 - P\_ValveMPAdv Display Element Description**

Display Element Name	Display Element	Description
GO_P_ValveMPAdv2D		This Advanced Mix-proof Valve graphic object allows for numerous orientations on displays.
GO_P_ValveMPAdv_Orth		This 3-D orthogonal Advanced Mix-proof Valve graphic object provides different valve angle positions on displays.
GO_P_ValveMPAdv_Orth1		This 3-D orthogonal Advanced Mix-proof Valve graphic object provides different valve angle positions on displays.

## Operator Tab

The Faceplate initially opens to the Operator (Home) tab. From here, an operator can monitor the device status and manually operate the device when it is in Operator command source. Several features are common to all Add-On Instructions faceplates for the valves family. See [Common Valves Faceplates on page 411](#).



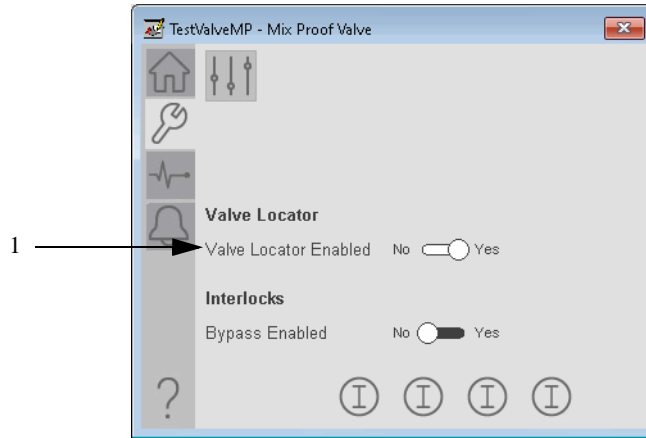
**Table 321 - Operator Tab Description**

Item	Description
1	Click to go to the Lift Valve Upper Seat state.
2	Click to go to the CIP/SIP Valve Cavity state.
3	Click to go to the CIP/SIP Valve Upper Seat state.
4	Click to go to the CIP/SIP Valve Lower Seat state.
5	Click to go to the Lift Valve Lower Seat state.

## Maintenance Tab

Maintenance personnel use the information and controls on the Maintenance tab to adjust device parameters, troubleshoot, temporarily work around device problems, and disable the device for routine maintenance. Several features are common to all Add-On Instructions faceplates for the valves family.

See [Common Valves Faceplates on page 411](#).



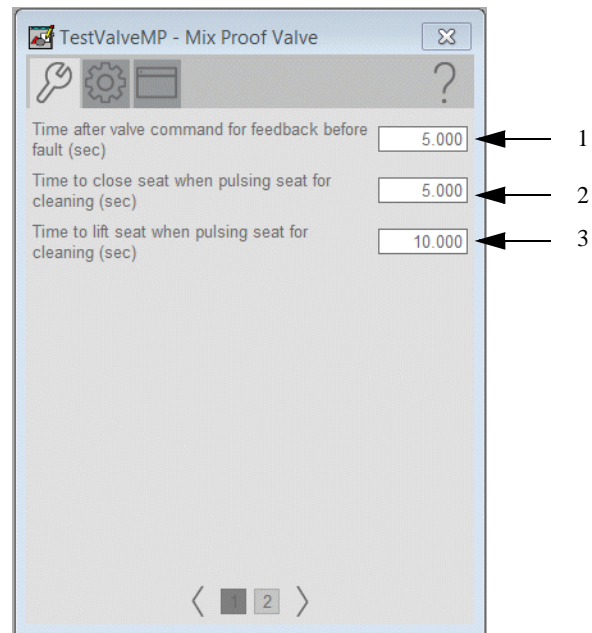
Item	Description
1	Select Yes to enable the valve locator. When yes is selected the valve locator lamp will be illuminated



## Advanced Properties Display

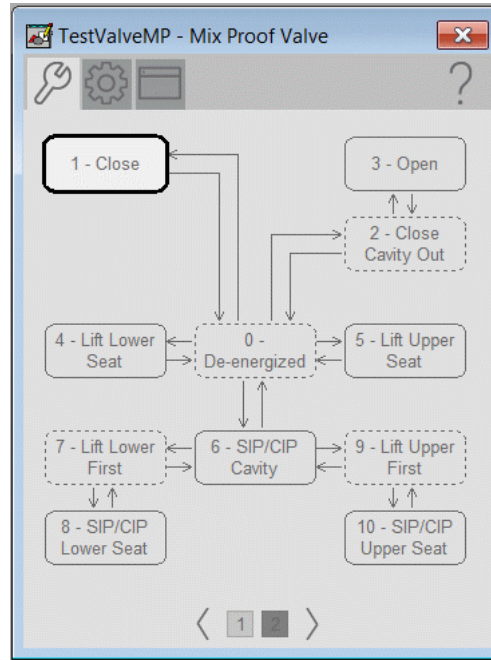
The Advanced Properties Display opens to the advanced maintenance settings. The Advanced Properties Display provides access to device configuration parameters and ranges, and options for device and I/O setup. This tab is used for initial system commissioning or later system changes.

### Advanced Maintenance Tab



**Table 322 - Advanced Maintenance Tab Page 1 Description**

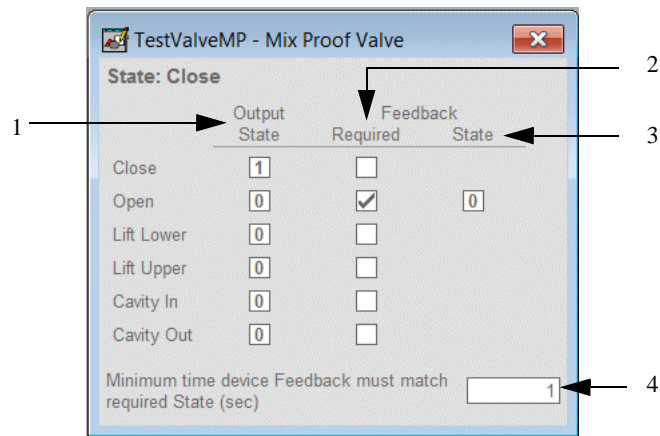
Item	Description
1	Type a value (seconds) that gives the valve time to achieve state before triggering a valve failure fault.
2	Type a value (seconds) that the valve seat is held closed when pulsing for cleaning.
3	Type a value (seconds) that the valve seat is held open when pulsing for cleaning.



**Table 323 - Advanced Maintenance Tab Page 2 Description**

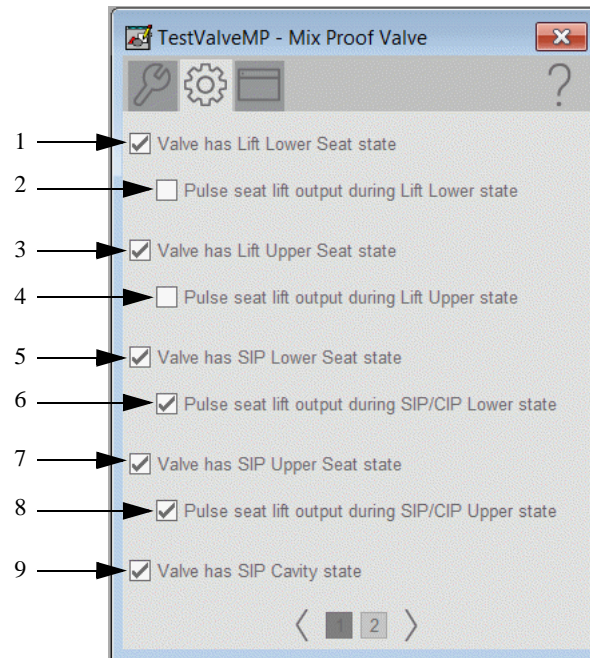
Item	Description
1	Click a state box to open the State Configuration display to access configuration parameters for the valve state

*State Configuration Display*

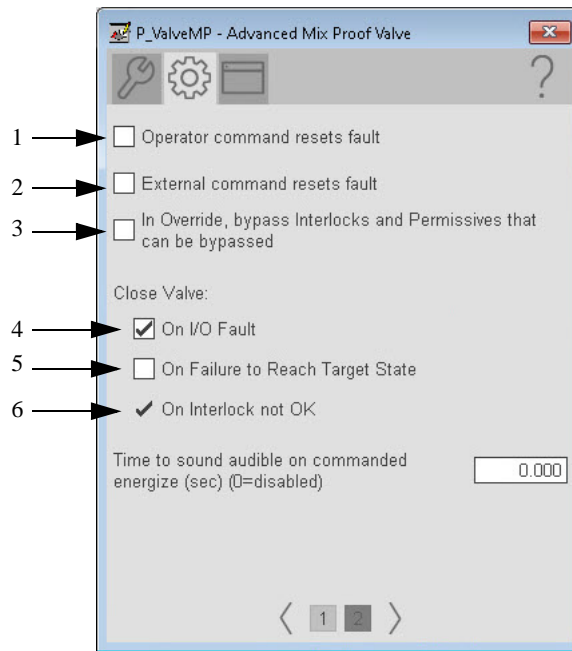


**Table 324 - State Configuration Display Description**

Item	Description
1	Set State of each Output in the selected valve state.
2	Check to require a feedback signals for the selected valve state.
3	Sets the desired value of the feedback signals for the selected valve state.
4	Type a value (seconds) the feedback must match for the valve to achieve the selected state.

*Engineering Tab***Table 325 - Engineering Tab Page 1 Description**

Item	Description
1	Check to enable the lift lower seat state for the valve.
2	Check to enable pulsing in the lift lower state.
3	Check to enable the lift upper seat state for the valve.
4	Check to enable pulsing in the lift upper state.
5	Check to enable the SIP lower seat state for the valve.
6	Check to enable pulsing in the SIP/CIP lower state.
7	Check to enable the SIP upper seat state for the valve.
8	Check to enable pulsing in the SIP/CIP upper state.
9	Check to enable the SIP cavity state for the valve.

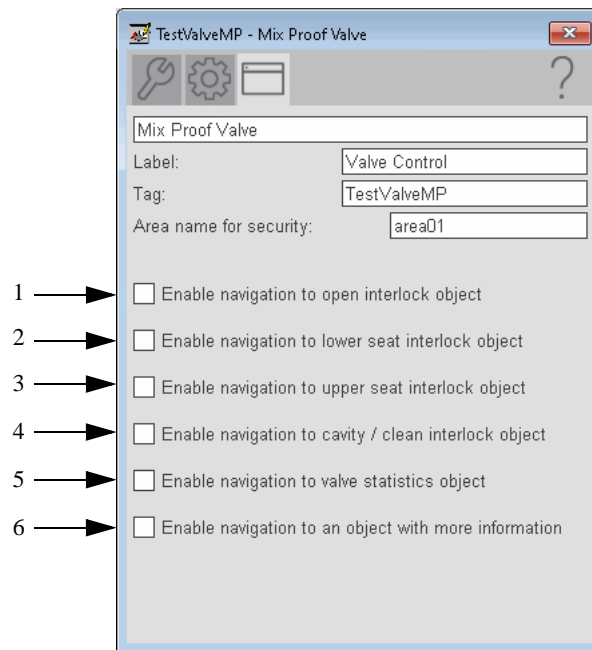


**Table 326 - Engineering Tab Page 2 Description**

Item	Description
1	Check to reset a fault on a new Operator command.
2	Check to reset a fault on a new External command.
3	Check to bypass permissives and interlocks in Override command source.
4	Check to close the valve when an I/O Fault occurs. A reset is required to clear this latched shed condition. Clear this checkbox to show only the I/O fault status/alarm and not trip the valve if an I/O fault is detected.
5	Check to close the valve when a Position Fail occurs. A reset is required to clear this latched shed condition. Clear this checkbox to show only the Position Fail status/alarm and not trip the valve if a Position Fail is detected.
6	The device always sheds (closes) on an interlock not OK. This item cannot be unchecked. It is displayed as a reminder that the interlock not OK function always triggers a shed.

## HMI Configuration Tab

The HMI configuration tab provides access to displayed text, and faceplate-to-faceplate navigation settings. Configure the description, label, tag, and security area for the device. See [Basic Faceplate Attributes on page 32](#) for the description of the common attributes.



**Table 327 - HMI Configuration Tab Description**

Item	Description
1	Check if a valve Open Interlock object is used with this valve. This check changes the Open Interlock indicator to a clickable button to open the Interlock faceplate associated with the Open functions of this valve. <b>IMPORTANT:</b> The name of the interlock object in the controller must be the name of the object with the suffix '_OpenIntlk'. For example, if your P_ValveMPAdv object has the name 'ValveMP123', then its open interlock object must be named 'ValveMP123_OpenIntlk'.
2	Check if a valve Lower Seat Interlock object is used with this valve. This check changes the Lower Seat Interlock indicator to a clickable button to open the Interlock faceplate associated with the Lower Seat functions of this valve. <b>IMPORTANT:</b> The name of the interlock object in the controller must be the name of the object with the suffix '_LowerSeatIntlk'. For example, if your P_ValveMPAdv object has the name 'ValveMP123', then its lower seat interlock object must be named 'ValveMP123_LowerSeatIntlk'.
3	Check if a valve Upper Seat Interlock object is used with this valve. This check changes the Upper Seat Interlock indicator to a clickable button to open the Interlock faceplate associated with the Upper Seat functions of this valve. <b>IMPORTANT:</b> The name of the interlock object in the controller must be the name of the object with the suffix '_UpperSeatIntlk'. For example, if your P_ValveMPAdv object has the name 'ValveMP123', then its upper seat interlock object must be named 'ValveMP123_UpperSeatIntlk'.

Item	Description
4	<p>Check if a valve Cavity Interlock object is used with this valve. This check changes the Cavity Interlock indicator to a clickable button to open the Interlock faceplate associated with the cavity and clean (CIP/SIP) functions of this valve.</p> <p><b>IMPORTANT:</b> The name of the interlock object in the controller must be the name of the object with the suffix '_CavityIntlk'. For example, if your P_ValveMPAdv object has the name 'ValveMP123', then its cavity interlock object must be named 'ValveMP123_CavityIntlk'.</p>
5	<p>Check if the Valve Stats instruction (for example, P_ValveStats) is used with this device. This check adds a button to the faceplate that opens the Valve Stats faceplate.</p> <p><b>IMPORTANT:</b> The name of the Valve Statistics object in the controller must be the name of the object with the suffix '_ValveStats'. For example, if your P_ValveMPAdv object has the name 'ValveMP123', then its Interlock object must be named 'ValveMP123_ValveStats'.</p>
6	<p>Check to enable navigation to an object with more information (Cfg_HasMoreObj is set to true.)</p> <p>This can be configured to navigate to an AOI backing tag or a UDT tag that has HMI_Type and HMI_Lib defined.</p> <p>For example, there is a motor with the tag name P_101 and there is a need to have the more information button navigate to the parent P_LLS object. A tag is created for the P_LLS object that is given the alias P101_More. When the more information button is pressed on the motor, it links to P101_More. This will open the faceplate for the LLS object.</p>

## Diagnostics Tab

The Diagnostic tab provides indications that are helpful to diagnose or help prevent device problems. The device problems can include specific reasons a device is 'Not Ready', device warnings and faults, warning and fault history, and predictive/preventive maintenance data.

The Diagnostics tab displays possible reasons for the device not being ready. See [Diagnostics Tab on page 36](#)

## Alarms Tab

The Alarms tab displays each configured alarm. The icon on the tab for the alarms page changes color to show the current active alarm status. A blinking alarm icon indicates that one or more alarms must be acknowledged or the device must be reset. See [Common Alarm Block \(P\\_Alarm\) on page 66](#) for more information.

## Solenoid-operated Valve (P\_ValveSO)

The P\_ValveSO (Solenoid-operated Valve) Add-On Instruction is used to operate (open and close) a solenoid-operated valve in various command sources, monitoring for fault conditions.

This document is for the visualization files, display elements, global objects, and HMI information. The operation of the Add-on Instructions and controller code is contained in publication [PROCES-RM013](#).

### Display Elements

A display element (global object) is created once and can be referenced multiple times on multiple displays in an application. When changes are made to the original (base) object, the instantiated copies (reference objects) are automatically updated. Use of global objects, with tag structures in the ControlLogix system, aid consistency and save engineering time.

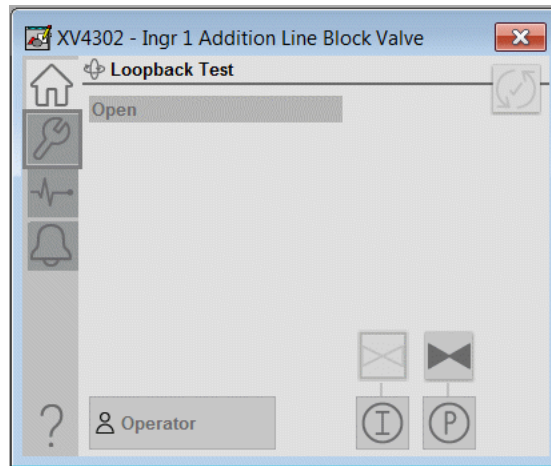
**Table 328 - P\_ValveSO Display Element Description**

Display Element Name	Display Element	Description
P_ValveSO P_ValveSO1 P_ValveSO2 P_ValveSO3		Standard solenoid-operated valve global objects.



## Operator Tab

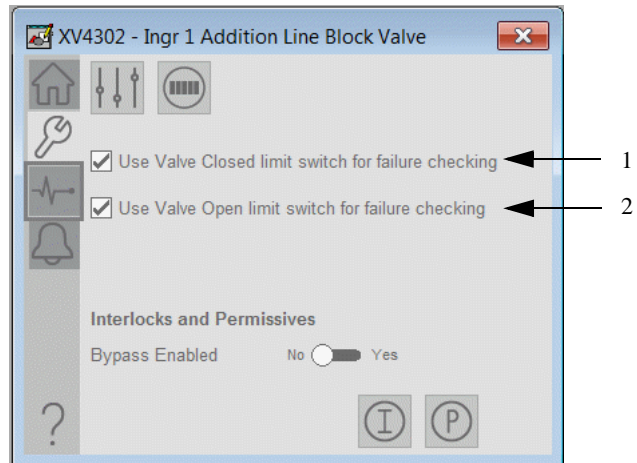
The Faceplate initially opens to the Operator (Home) tab. From here, an operator can monitor the device status and manually operate the device when it is in Operator command source. Several features are common to all Add-On Instructions faceplates for the valves family. See [Common Valves Faceplates on page 411](#).



## Maintenance Tab

Maintenance personnel use the information and controls on the Maintenance tab to adjust device parameters, troubleshoot, temporarily work around device problems, and disable the device for routine maintenance. Several features are common to all Add-On Instructions faceplates for the valves family.

See [Common Valves Faceplates on page 411](#).



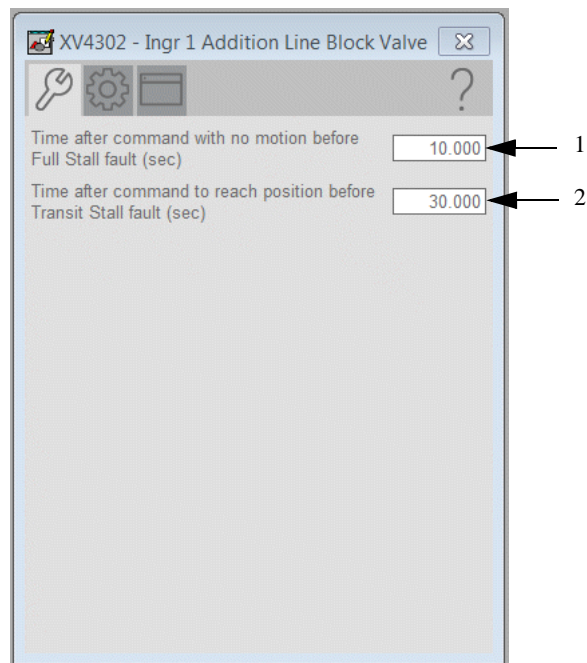
**Table 329 - Maintenance Tab Description**

Item	Description
1	Check if the instruction uses the closed limit switch feedback to check for valve full stall or transit stall.
2	Check if the instruction uses the open limit switch feedback to check for valve full stall or transit stall.

## Advanced Properties Display

The Advanced Properties Display opens to the advanced maintenance settings. The Advanced Properties Display provides access to device configuration parameters and ranges, and options for device and I/O setup. This tab is used for initial system commissioning or later system changes.

### *Advanced Maintenance Tab*



**Table 330 - Advance Maintenance Tab Description**

Item	Description
1	Type the amount of time to allow for the valve to move off the current position before raising a Full Stall alarm.
2	Type the amount of time to allow for completing valve travel before raising a Transit Stall alarm.

Engineering Tab

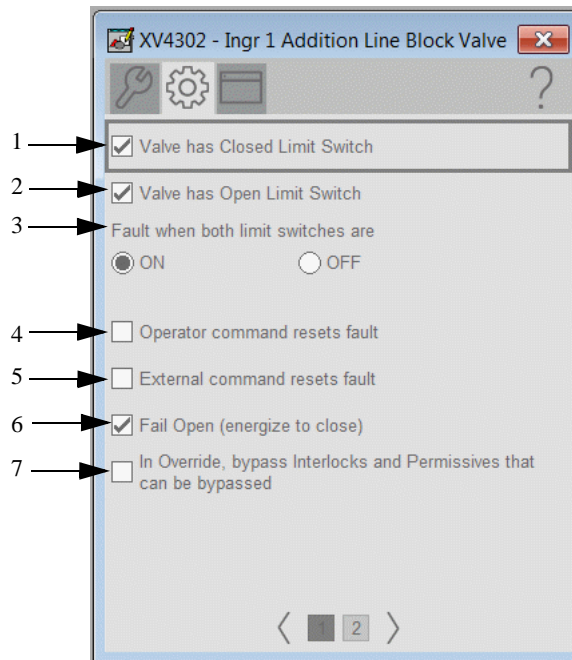


Table 331 - Engineering Tab Page 1 Description

Item	Description
1	Check if the valve has a closed limit switch and the switch is wired to Inp_ClosedLS for position monitoring.
2	Check if the valve has an open limit switch and the switch is wired to Inp_OpenLS for position monitoring.
3	Click ON if both limit switches are OFF when the valve is in motion. Click OFF if both limit switches are ON when the valve is in motion. This selection determines how the instruction detects a stuck limit switch.
4	Check to allow an Operator Open or Close command to reset any previous faults (I/O Fault, Transit Stall, Full Stall, Interlock Trip), then open or close the valve. Clear this checkbox to reset faults by using the Reset command.
5	Check to allow an External Open or Close command to reset any previous faults (I/O Fault, Transit Stall, Full Stall, Interlock Trip), then open or close the valve. Clear this checkbox to reset faults by using the Reset command.
6	Check if the valve fails Open for energize-to-close operation. Clear this checkbox if the valve fails Closed for energize-to-open operation.
7	Check to bypass interlocks and permissives (that can be bypassed) in Override command source.

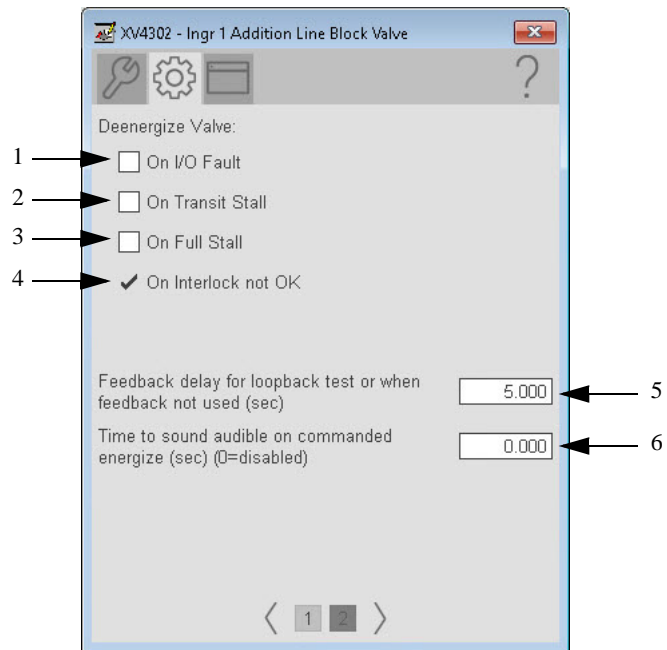
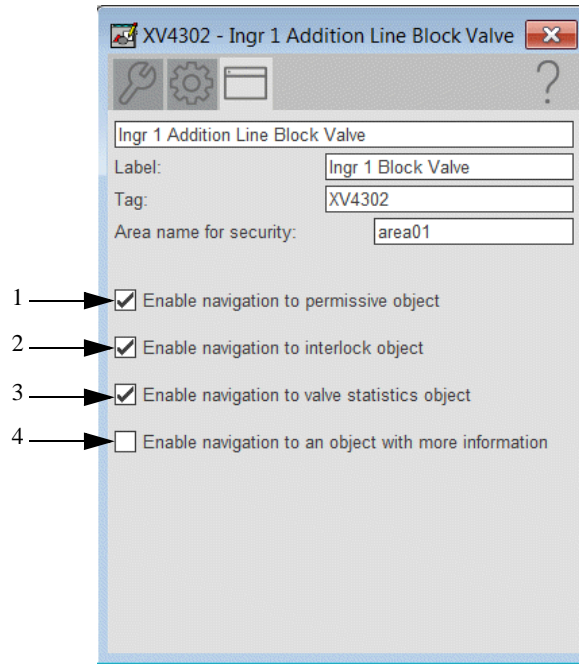


Table 332 - Engineering Tab Page 2 Description

Item	Description
1	<p>Check to de-energize the output to the valve and return it to its fail position, when an I/O Fault condition occurs.</p> <p>Clear this checkbox to keep the output to the valve in its current state on an I/O Fault condition.</p> <p><b>IMPORTANT:</b> When this checkbox is checked and an I/O Fault condition occurs, a Reset is required before the valve can be energized.</p>
2	<p>Check to de-energize the output to the valve and attempt to return it to its fail position, when a Transit Stall condition occurs.</p> <p>Clear this checkbox to keep the output to the valve in its current state (keep trying) on a Transit Stall condition. (A Transit Stall means the valve, when commanded to move, moved off its original position, but did not reach its commanded position before the Transit Stall time expired.)</p> <p><b>IMPORTANT:</b> When this checkbox is checked and a Transit Stall condition occurs, a Reset is required before the valve can be energized.</p>
3	<p>Check to de-energize the output to the valve, attempting to return it to its fail position, when a Full Stall condition occurs.</p> <p>Clear this checkbox to keep the output to the valve in its current state (keep trying) on a Full Stall condition. (A Full Stall means the valve, when commanded to move, did not move off its original position before the Full Stall time expired.)</p> <p><b>IMPORTANT:</b> When this checkbox is checked and a Full Stall condition occurs, a Reset is required before the valve can be energized.</p>
4	<p>The valve outputs are always de-energized on an Interlock not OK. This item cannot be unchecked. It is displayed as a reminder that the Interlock not OK function always de-energizes the valve.</p>
5	<p>Sets the time delay (in seconds) for the opened or closed status to be echoed back when Simulation is enabled or when limit switch feedback is not used.</p>
6	<p>Type the seconds to sound an audible alarm when the valve energizes.</p>

### HMI Configuration Tab

The HMI configuration tab provides access to displayed text, and faceplate-to-faceplate navigation settings. Configure the description, label, tag, and security area for the device. See [Basic Faceplate Attributes on page 32](#) for the description of the common attributes.



**Table 333 - HMI Configuration Tab Description**

Item	Description
1	Check if a permissive object is connected to the Permissive input. This action changes the Permissive indicator to a clickable button. <b>IMPORTANT:</b> The name of the Permissive object in the controller must be the name of the object with the suffix ‘_Perm’. For example, if your P_ValveSO object has the name ‘ValveSO123’, then its Permissive object must be named ‘ValveSO123_Perm’.

Item	Description
2	<p>Check if an interlock object is connected to the Interlock input. This action changes the Interlock indicator to a clickable button.</p> <p><b>IMPORTANT:</b> The name of the Interlock object in the controller must be the name of the object with the suffix ‘_Intlk’. For example, if your P_ValveSO object has the name ‘ValveSO123’, then its Interlock object must be named ‘ValveSO123_Intlk’.</p>
3	<p>Check if a Valve Stats object is used with this valve. This action makes the Valve Statistics button visible.</p> <p><b>IMPORTANT:</b> The name of the Valve Stats object in the controller must be the name of the object with the suffix ‘_ValveStats’. For example, if your P_ValveSO object has the name ‘ValveSO123’, then its Valve Stats object must be named ‘ValveSO123_ValveStats’.</p>
4	<p>Check to enable navigation to an object with more information (Cfg_HasMoreObj is set to true.)</p> <p>This can be configured to navigate to an AOI backing tag or a UDT tag that has HMI_Type and HMI_Lib defined.</p> <p>For example, there is a motor with the tag name P_101 and there is a need to have the more information button navigate to the parent P_LLS object. A tag is created for the P_LLS object that is given the alias P101_More. When the more information button is pressed on the motor, it links to P101_More. This will open the faceplate for the LLS object.</p>

## Diagnostics Tab

The Diagnostic tab provides indications that are helpful to diagnose or help prevent device problems. The device problems can include specific reasons a device is 'Not Ready', device warnings and faults, warning and fault history, and predictive/preventive maintenance data.

The Diagnostics tab displays possible reasons for the device not being ready. See [Diagnostics Tab on page 36](#)

## Alarms Tab

The Alarms tab displays each configured alarm. The icon on the tab for the alarms page changes color to show the current active alarm status. A blinking alarm icon indicates that one or more alarms must be acknowledged or the device must be reset. See [Common Alarm Block \(P\\_Alarm\) on page 66](#) for more information.



## 2-state Valve Statistics (P\_ValveStats)

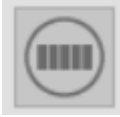
The P\_ValveStats (2-state Valve Statistics) Add-On Instruction monitors a 2-state (open and close) valve and records various statistics that are related to stroke times and stroke counts.

This document is for the visualization files, display elements, global objects, and HMI information. The operation of the Add-on Instructions and controller code is contained in publication [PROCES-RM013](#).

### Display Elements

A display element (global object) is created once and can be referenced multiple times on multiple displays in an application. When changes are made to the original (base) object, the instantiated copies (reference objects) are automatically updated. Use of global objects, with tag structures in the ControlLogix system, aid consistency and save engineering time.

**Table 334 - P\_ValveStats Display Element Description**

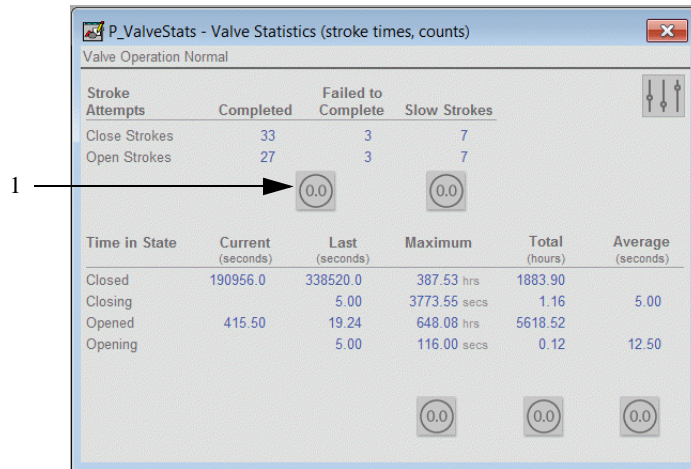
Display Element Name	Display Element	Description
GO_P_ValveStats		This GO_P_ValveStats object can be added to application graphics to access valve statistics. A similar object is already included on faceplates for 2-state valves to provide access to valve statistics.

## Operator Tab

The Faceplate initially opens to the Operator (Home) tab. From here, an operator can monitor the device status and manually operate the device when it is in Operator command source. Several features are common to all Add-On Instructions faceplates for the valves family. See [Common Valves Faceplates on page 411](#).

The Operator tab shows the following information:

- Completion information and moving average for close and open strokes.
- Count and last stroke information for slow close and slow open strokes.
- Current, last, maximum, and total time in different states.



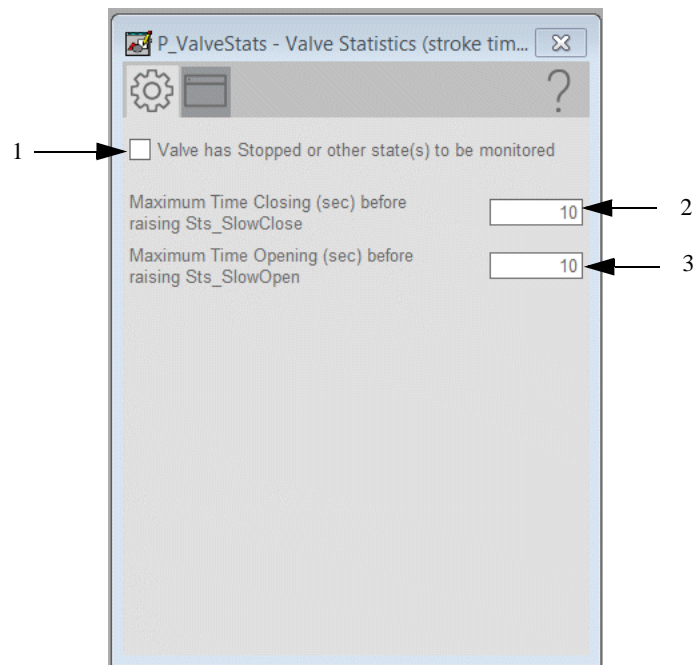
**Table 335 - Operator Tab Description**

Item	Description
1	Click this symbol to reset an accumulated time or count.

## Advanced Properties Display

The Advanced Properties Display opens to the engineering settings. The Advanced Properties Display provides access to device configuration parameters and ranges, and options for device and I/O setup. This tab is used for initial system commissioning or later system changes.

### Engineering Tab

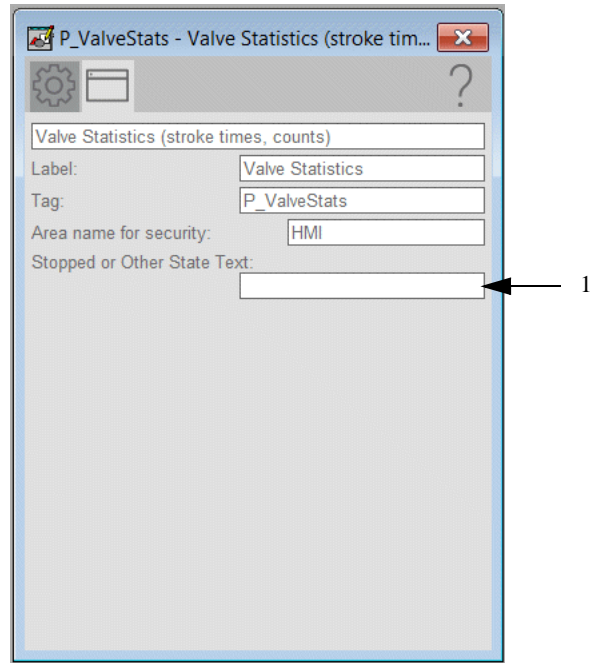


**Table 336 - Engineering Tab Description**

Item	Description
1	Check when a valve has stopped or other state to monitor.
2	Type the number of seconds to give the valve to close before counting a slow close stroke.
3	Type the number of seconds to give the valve to open before counting a slow open stroke.

### HMI Configuration Tab

The HMI configuration tab provides access to displayed text, and faceplate-to-faceplate navigation settings. Configure the description, label, tag, and security area for the device. See [Basic Faceplate Attributes on page 32](#) for the description of the common attributes.



**Table 337 - HMI Configuration Tab Description**

Item	Description
1	Type a name for the Stopped or other state of the valve.

## **Diagnostics Tab**

The Diagnostic tab provides indications that are helpful to diagnose or help prevent device problems. The device problems can include specific reasons a device is 'Not Ready', device warnings and faults, warning and fault history, and predictive/preventive maintenance data.

The Diagnostics tab displays possible reasons for the device not being ready. See [Diagnostics Tab on page 36](#)

## **Alarms Tab**

The Alarms tab displays each configured alarm. The icon on the tab for the alarms page changes color to show the current active alarm status. A blinking alarm icon indicates that one or more alarms must be acknowledged or the device must be reset. See [Common Alarm Block \(P\\_Alarm\) on page 66](#) for more information.

## n-Position Device (P\_nPos)

The P\_nPos (n-Position Device) Add-On Instruction controls a circular or linear discrete device with 2...8 positions. The P\_nPos instruction provides outputs to select an individual position and outputs to move toward increasing positions ('clockwise' for a circular device) or decreasing positions ('counterclockwise' for a circular device).

For linear devices, the P\_nPos instruction can be configured to return to Position 1 on every move, approaching the target position from the 'same side' on each move to improve position repeatability, or move directly to the new position.





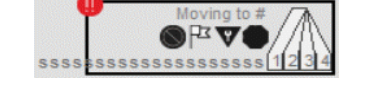
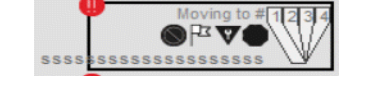
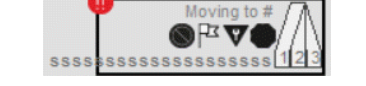

For circular devices, the P\_nPos instruction can be configured to move only 'clockwise' to increase positions (for example, 6, 7, 8, 1, 2...). The instruction can also be configured to move both directions by using the shortest move (for example, 'clockwise' from 6...1: 6, 7, 8, 1; or 'counterclockwise' from 2...7: 2, 1, 8, 7).

This document is for the visualization files, display elements, global objects, and HMI information. The operation of the Add-on Instructions and controller code is contained in publication [PROCES-RM013](#).

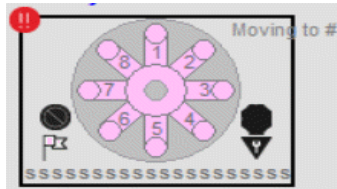
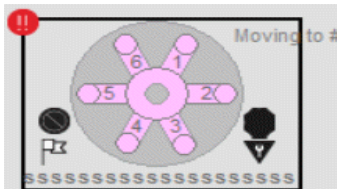
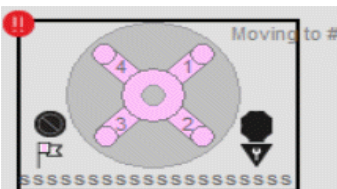
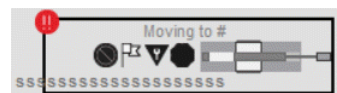
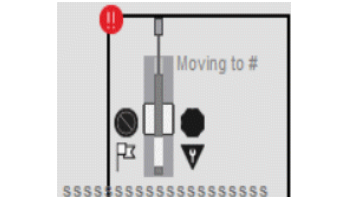
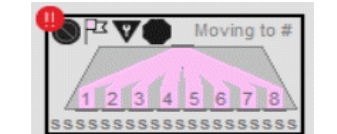
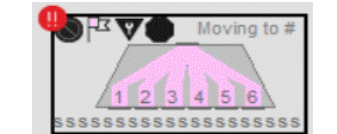
## Display Elements

A display element (global object) is created once and can be referenced multiple times on multiple displays in an application. When changes are made to the original (base) object, the instantiated copies (reference objects) are automatically updated. Use of global objects, with tag structures in the ControlLogix system, aid consistency and save engineering time.

**Table 338 - P\_nPos Display Elements Description**

Display Element Name	Display Element	Description
GO_P_nPos_8SelValve		These display elements are used for routing one flow path to many vertically. These elements show all 3, 4, 6, or 8 ports and unused ports are not hidden.
GO_P_nPos_8SelValve1		
GO_P_nPos_6SelValve		
GO_P_nPos_6SelValve1		
GO_P_nPos_4SelValve		
GO_P_nPos_4SelValve1		
GO_P_nPos_3SelValve		
GO_P_nPos_3SelValve1		

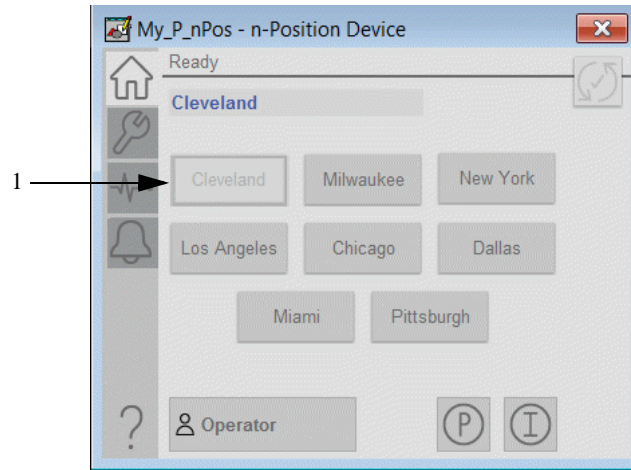
**Table 338 - P\_nPos Display Elements Description**

Display Element Name	Display Element	Description
GO_P_nPos_8PosRotary	 <p>The image shows a circular rotary valve with 8 ports labeled 1 through 8. A red exclamation mark icon is in the top left. The text 'Moving to #' is in the top right. Below the valve is a row of 16 'S' characters. The valve is currently pointing towards the top-right position.</p>	<p>These display elements are used for rotary selection from one port to many ports. Only the ports that are enabled are displayed. For example, if you configure the P_nPos instruction with five positions, ports 6, 7, and 8 are not displayed.</p>
GO_P_nPos_6PosRotary	 <p>The image shows a circular rotary valve with 6 ports labeled 1 through 6. A red exclamation mark icon is in the top left. The text 'Moving to #' is in the top right. Below the valve is a row of 16 'S' characters. The valve is currently pointing towards the top-right position.</p>	
GO_P_nPos_4PosRotary	 <p>The image shows a circular rotary valve with 4 ports labeled 1 through 4. A red exclamation mark icon is in the top left. The text 'Moving to #' is in the top right. Below the valve is a row of 16 'S' characters. The valve is currently pointing towards the top-right position.</p>	
GO_P_nPos_Slide Gate	 <p>The image shows a linear multi-position device with a slider. A red exclamation mark icon is in the top left. The text 'Moving to #' is in the top right. Below the device is a row of 16 'S' characters.</p>	
GO_P_nPos_Slide Gate1	 <p>The image shows a linear multi-position device with a slider. A red exclamation mark icon is in the top left. The text 'Moving to #' is in the top right. Below the device is a row of 16 'S' characters.</p>	<p>These display elements show a linear multi-position device. The symbol is animated to show the position that is based on the number of positions configured.</p>
GO_P_nPos	 <p>The image shows a linear multi-position device with 8 positions labeled 1 through 8. A red exclamation mark icon is in the top left. The text 'Moving to #' is in the top right. Below the device is a row of 16 'S' characters.</p>	
GO_P_nPos1	 <p>The image shows a linear multi-position device with 6 positions labeled 1 through 6. A red exclamation mark icon is in the top left. The text 'Moving to #' is in the top right. Below the device is a row of 16 'S' characters.</p>	<p>These display elements are similar to those elements shown on the first page of this table, but ports that aren't configured are not displayed.</p>



## Operator Tab

The Faceplate initially opens to the Operator (Home) tab. From here, an operator can monitor the device status and manually operate the device when it is in Operator command source. Several features are common to all Add-On Instructions faceplates for the valves family. See [Common Valves Faceplates on page 411](#).



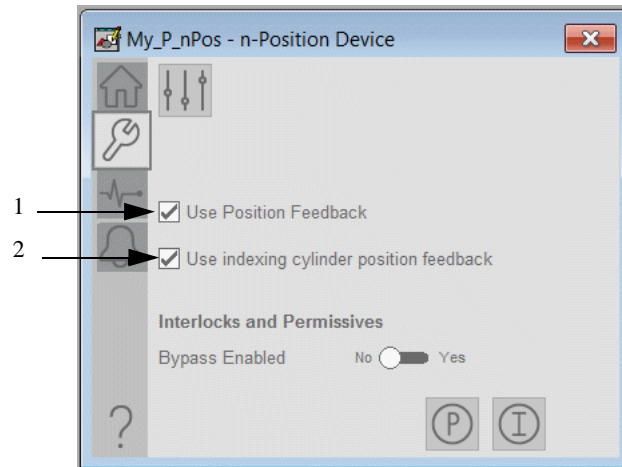
**Table 339 - Operator Tab Description**

Item	Description
1	Current Device Position.

## Maintenance Tab

Maintenance personnel use the information and controls on the Maintenance tab to adjust device parameters, troubleshoot, temporarily work around device problems, and disable the device for routine maintenance. Several features are common to all Add-On Instructions faceplates for the valves family.

See [Common Valves Faceplates on page 411](#).



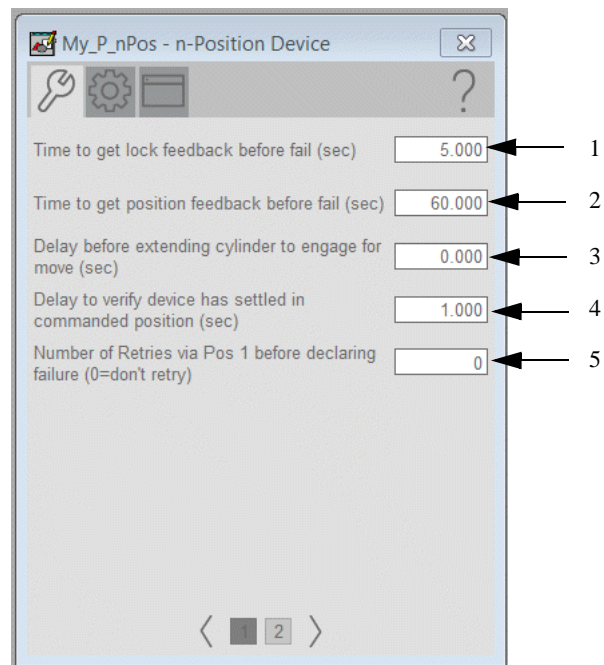
**Table 340 - Maintenance Tab Description**

Item	Description
1	Check to have the instruction use the Position Feedback to check the position of the device.
2	Check to have the instruction use the index cylinder position feedback.

## Advanced Properties Display

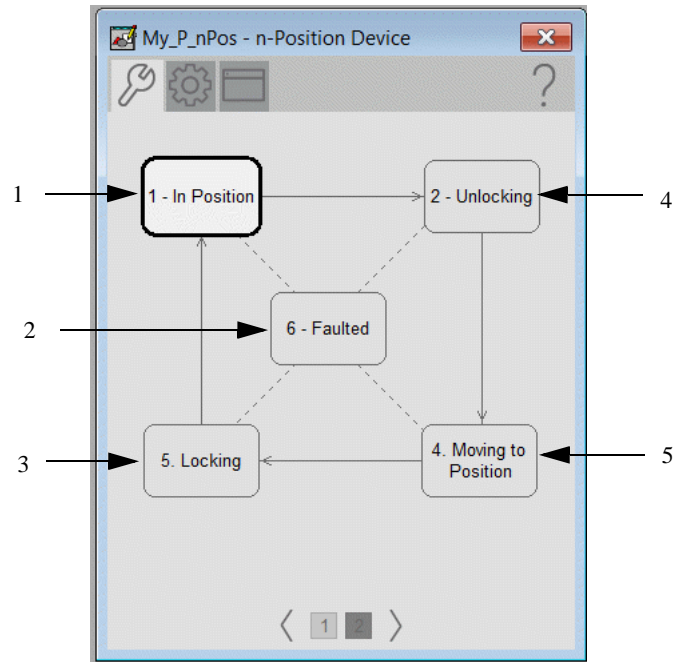
The Advanced Properties Display opens to the advanced maintenance settings. The Advanced Properties Display provides access to device configuration parameters and ranges, and options for device and I/O setup. This tab is used for initial system commissioning or later system changes.

### Advanced Maintenance Tab



**Table 341 - Advanced Maintenance Tab Page 1 Description**

Item	Description
1	Type a value (0...2,147,483) that indicates the maximum time that is allowed for lock feedback before a fail.
2	Type a value (0...2,147,483) that indicates the maximum time that is allowed for the device to be in position before a fail.
3	Type a value (0...2,147,483) that indicates the time delay before engaging a cylinder move.
4	Type a value (0...2,147,483) that indicates the delay time to verify that a device is in a commanded position.
5	Type a value (0...2,147,483) to indicate the number of retries for a device in Position 1 before a fault is set.

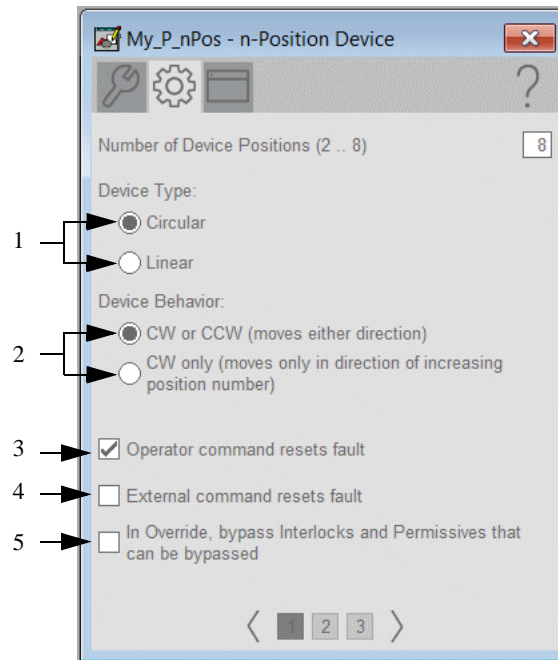


**Table 342 - Advanced Maintenance Tab Page 2 Description**

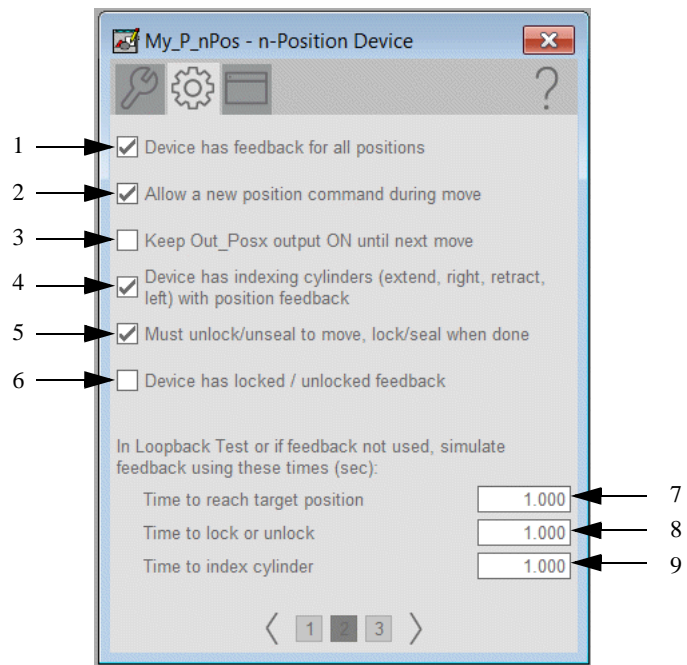
Item	Description
1	This state is highlighted whenever the device is in the position that it was last commanded.
2	This state is highlighted if the device feedback fails to confirm that the device is unlocked, moved to position, or locked as requested within the configured failure times.
3	This state is displayed only if the device is configured with a lock or seal that must be unlocked or unsealed to move. This state is highlighted when the device has reached its commanded position and has been commanded to lock, but locked feedback has not been received yet.
4	This state is displayed only if the device is configured with a lock or seal that must be unlocked or unsealed to move. This state is highlighted when the device has been commanded to unlock, but unlocked feedback has not been received yet.
5	This state is highlighted when the device is being moved to its commanded position, but that position feedback has not been received yet.

There is an additional state that is not identified in this diagram.

- State 3 - Moving to Position - This state is displayed only if the device is configured as a linear device that returns to position 1 on every move. This strategy is used to approach each position from the same side. This state is highlighted when the device has been unlocked and is being moved to position 1, but position 1 feedback has not been received yet.

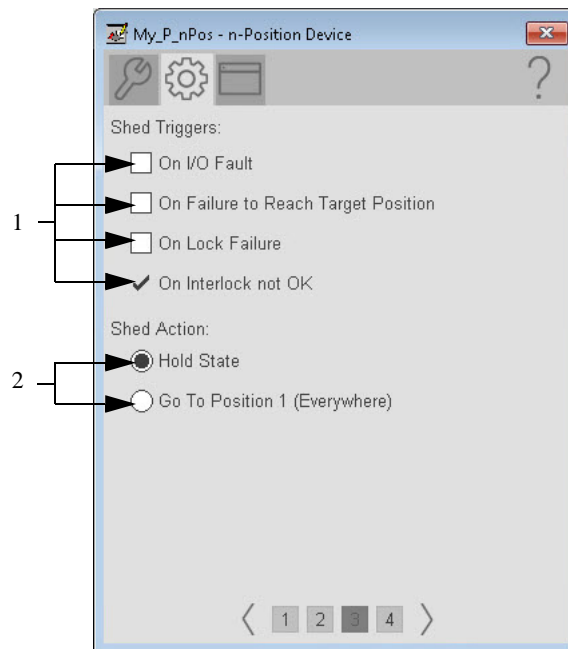
*Engineering Tab***Table 343 - Engineering Tab Page 1 Description**

Item	Description
1	Click circular or linear for the device type.
2	For Circular, click either clockwise only or clockwise or counterclockwise.  For Linear, click whether the device returns to Position 1 for every move or moves directly to the target position.
3	Check to reset a fault on a new Operator command.
4	Check to reset a fault on a new External command.
5	Check to bypass permissives and interlocks in Override command source.



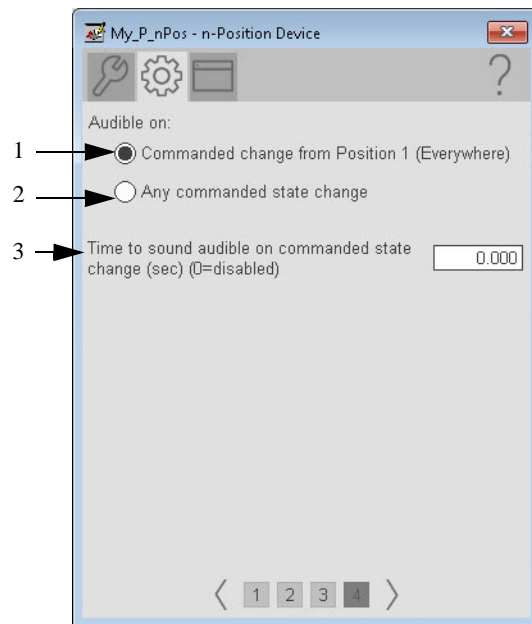
**Table 344 - Engineering Tab Page 2 Description**

Item	Description
1	Check to enable device feedback for all positions.
2	Check to enable a new position command to be received and processed while a move is in progress.
3	Check to keep a position output On until the next move.
4	Check to enable indexing cylinders with position feedback.
5	Check if the device must be unlocked to move and locked when the move is complete.
6	Check if the device has feedback for locked/unlocked positions.
7	Type the time (0...2,147,483) to reach a target position in simulation.
8	Type the time (0...2,147,483) to lock/unlock with the device in simulation.
9	Type the time (0...2,147,483) to simulate index cylinder feedback in simulation.



**Table 345 - Engineering Tab Page 3 Description**

Item	Description
1	<p>Check to enable whether an I/O Fault, Failure to Reach Position, or Lock Failure is considered a shed condition.</p> <p>The device always sheds on an Interlock not OK. This item cannot be unchecked. It is displayed as a reminder that the Interlock not OK function always triggers a shed.</p> <p>If a condition causes the device to shed, a reset is required to operate the device.</p>
2	<p>Click to determine whether the device holds the hold position or goes to position 1 upon a shed condition.</p>



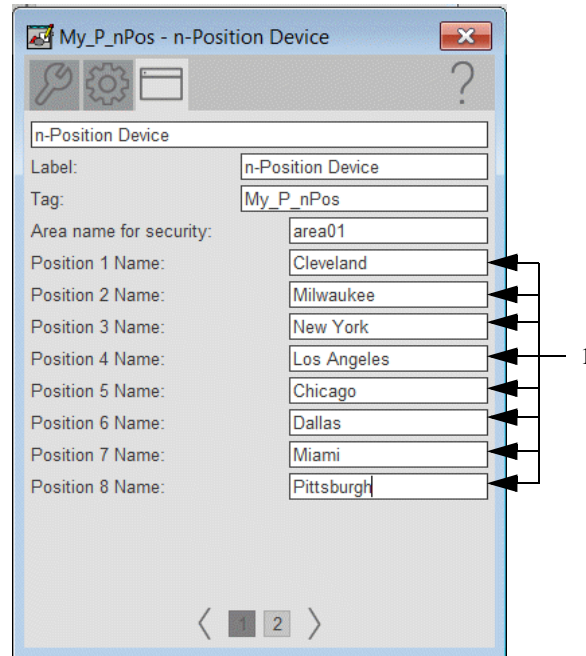
**Table 346 - Engineering Tab Page 4 Description**

Item	Description
1	Click to sound an audible on a commanded stage from Position 1.
2	Click to sound an audible on a commanded stage from any State.
3	Type the time (in seconds) that the audible sounds when there is a commanded State change.



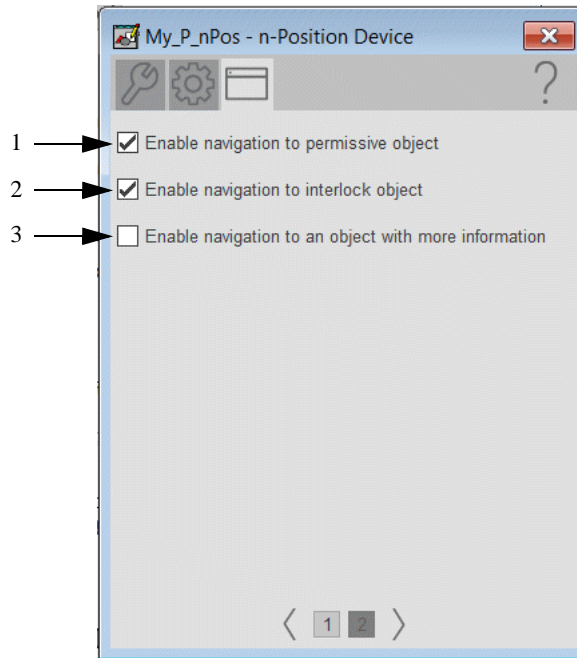
### HMI Configuration Tab

The HMI configuration tab provides access to displayed text, and faceplate-to-faceplate navigation settings. Configure the description, label, tag, and security area for the device. See [Basic Faceplate Attributes on page 32](#) for the description of the common attributes.



**Table 347 - HMI Configuration Page 1 Description**

Item	Description
1	Type a name for each device position that is based on the number of positions.



**Table 348 - HMI Configuration Page 2 Description**

Item	Description
1	<p>Check to indicate that a permissive object is connected to the permissive inputs of this object.</p> <p><b>IMPORTANT:</b> The name of the Permissives object in the controller must be the name of the object with the suffix ‘_Perm’. For example, if your P_nPos object has the name ‘nPos123’, then its Permissives object must be named ‘nPos123_Perm’.</p>
2	<p>Check to indicate that an interlock object is connected to the interlock inputs of this object.</p> <p><b>IMPORTANT:</b> The name of the Interlock object in the controller must be the name of the object with the suffix ‘_Intlk’. For example, if your P_nPos object has the name ‘nPos123’, then its Interlock object must be named ‘nPos123_Intlk’.</p>
3	<p>Check to enable navigation to an object with more information (Cfg_HasMoreObj is set to true.)</p> <p>This can be configured to navigate to an AOI backing tag or a UDT tag that has HMI_Type and HMI_Lib defined.</p> <p>For example, there is a motor with the tag name P_101 and there is a need to have the more information button navigate to the parent P_LLS object. A tag is created for the P_LLS object that is given the alias P101_More. When the more information button is pressed on the motor, it links to P101_More. This will open the faceplate for the LLS object.</p>

## **Diagnostics Tab**

The Diagnostic tab provides indications that are helpful to diagnose or help prevent device problems. The device problems can include specific reasons a device is 'Not Ready', device warnings and faults, warning and fault history, and predictive/preventive maintenance data.

The Diagnostics tab displays possible reasons for the device not being ready. See [Diagnostics Tab on page 36](#)

## **Alarms Tab**

The Alarms tab displays each configured alarm. The icon on the tab for the alarms page changes color to show the current active alarm status. A blinking alarm icon indicates that one or more alarms must be acknowledged or the device must be reset. See [Common Alarm Block \(P\\_Alarm\) on page 66](#) for more information.

## Discrete 2-, 3-, 4-state Device (P\_D4SD)

The P\_D4SD (Discrete 2-, 3-, 4-state Device) Add-On Instruction controls and monitors feedback from a discrete 2-state, 3-state, or 4-state device in various command sources, monitoring for fault conditions. These devices include multiple-speed motors or multiple-position valves.

See [Discrete 2-, 3-, 4-state Device \(P\\_D4SD\) on page 286](#)

This document is for the visualization files, display elements, global objects, and HMI information. The operation of the Add-on Instructions and controller code is contained in publication [PROCES-RM013](#).

**Notes:**



## Built-in Instructions Family

The faceplates that appear in this section are designed to let the function blocks and built-in firmware instructions for the Logix 5000 controllers interface with the Process Library Add-On Instructions. This document is for the visualization files, display elements, global objects, and HMI information. The operation of the Add-On Instructions and controller code is contained in publication [PROCES-RM013](#).

For details on built-in instructions, see the Logix 5000 Controllers Advanced Process Control and Drives Instructions Reference Manual, publication [1756-RM006](#).

### Proportional + Integral + Derivative Enhanced (PIDE) Autotune

The Studio 5000 Logix Designer® application PIDE autotuner provides an openloop autotuner that is built into the PIDE instruction. This function filters a signal to assist with the calculation of control variables. You can autotune from PanelView™ Plus terminals or any other operator interface devices and Logix Designer application.

The PIDE block has an Autotune Tag (type PIDE\_AUTOTUNE) that you specify for those PIDE blocks that you want to autotune.

---

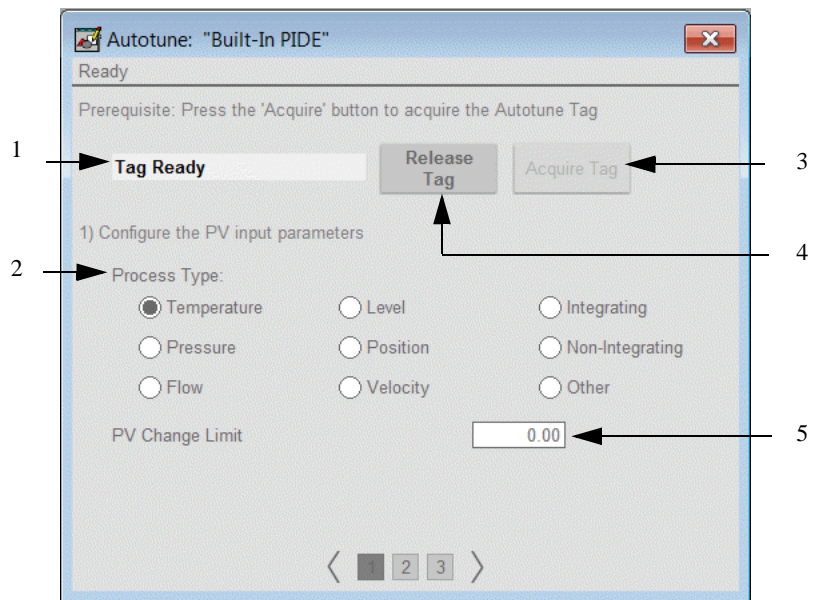
**IMPORTANT** The PIDE autotuner is installed with the Logix Designer application, but you need an activation key to enable the autotuner. The autotuner is supported only in function block programming; it is not available in relay ladder or structured text programming.

---

The Autotune function is accessed through the Advanced Maintenance tab of the Built-in PIDE faceplate.

This document is for the visualization files, display elements, global objects, and HMI information. The operation of the Add-On Instructions and controller code is contained in publication [PROCES-RM013](#).

## Autotune Page 1

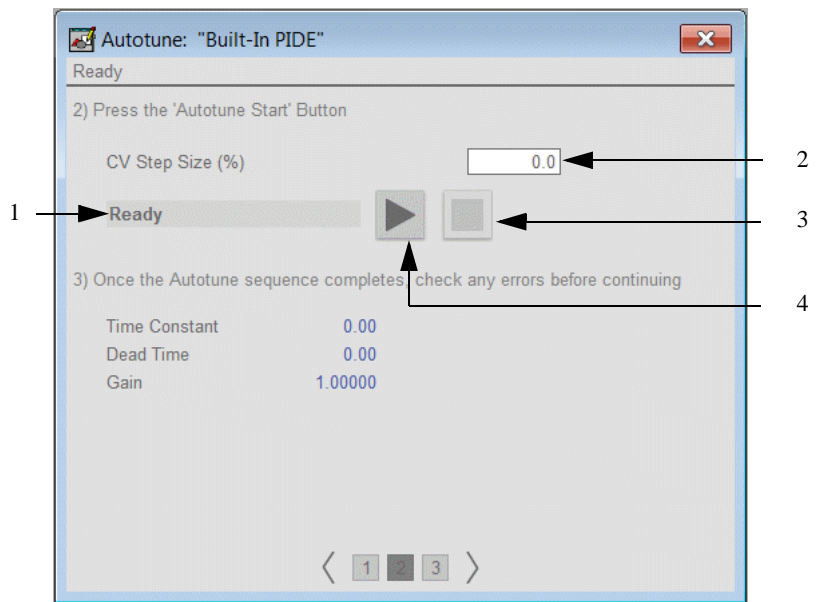


**Table 348 - Autotune Page 1 Description**

Item	Description
1	Tag Status Indicator
2	Click the item that best describes the process.
3	Click to acquire the Autotune tag.
4	Click to release the Autotune tag.
5	Type a value for the PV Change Limit. The autotune is aborted if the PV changes by more than this amount.



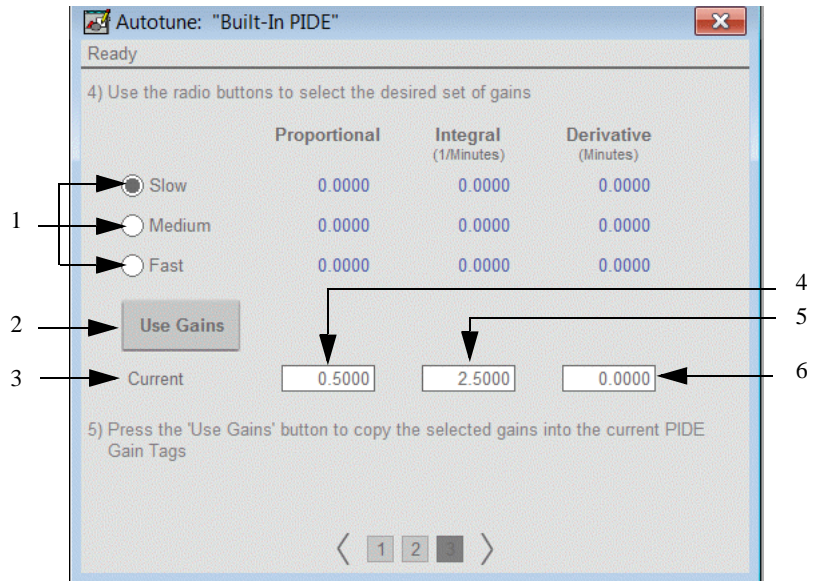
## Autotune Page 2



**Table 349 - Autotune Page 2 Description**

Item	Description
1	Autotune Status Indicator
2	Type a value for CV step size in percent for the tuning step test.
3	Click to start the Autotune process for CV1, CV2, and CV3.
4	Click to stop the Autotune process.

## Autotune Page 3



**Table 350 - Autotune Page 3 Description**

Item	Description
1	Click an option for response speed.
2	Press the 'Use Gains' button to copy the selected gains into the current PIDE gain tags.
3	Autotune Status Indicator
4	Type a value for Proportional gain.
5	Type a value for Integral gain.
6	Type a value for Derivative gain.

## Coordinated Control (CC)

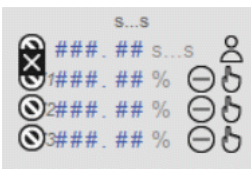
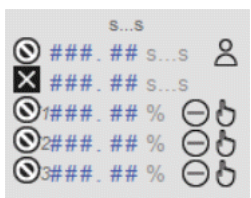

The Coordinated Control (CC) function block controls one process variable by manipulating as many as three different control variables. As an option, any of the three outputs can be used as an input to create feed forward action in the control variable. The CC function block calculates the control variables (CV1, CV2, and CV3) in the Auto mode based on the PV - SP deviation, internal models, and tuning.

This document is for the visualization files, display elements, global objects, and HMI information. The operation of the Add-On Instructions and controller code is contained in publication [PROCES-RM013](#).

### Display Elements

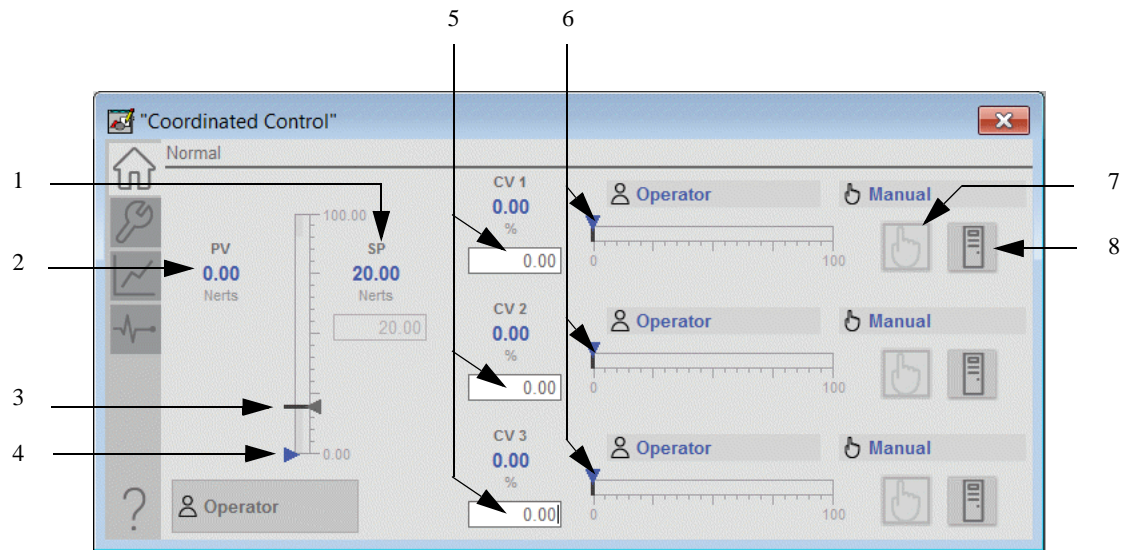
A display element (global object) is created once and can be referenced multiple times on multiple displays in an application. When changes are made to the original (base) object, the instantiated copies (reference objects) are automatically updated. Use of global objects, with tag structures in the ControlLogix® system, aid consistency and save engineering time.

**Table 351 - Coordinated Control Display Elements Description**

Display Element Name	Display Element	Description
GO_BuiltIn_CC		Coordinated Control object with a Process Variable and three Control Variables.
GO_BuiltIn_CC1		Coordinated Control object with a Process Variable, Setpoint, and three Control Variables.
GO_BuiltIn_CC2		Coordinated Control object with a Process Variable and a Setpoint.

## Operator Tab

The Faceplate initially opens to the Operator (Home) tab. From here, an operator can monitor the device status and manually operate the device when it is in Operator mode. Several features are common to all Add-On Instructions faceplates. See [Basic Faceplate Attributes on page 32](#).

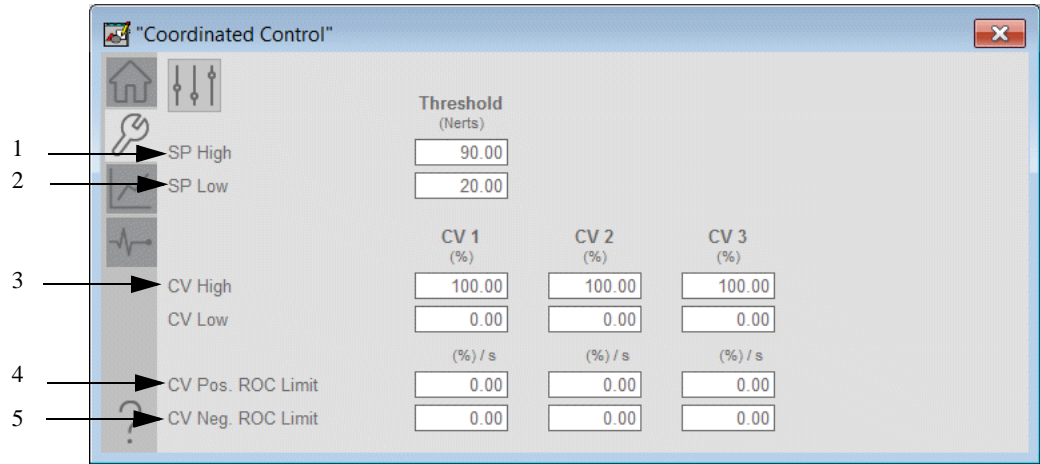


**Table 352 - Operator Tab Description**

Item	Description
1	Current setpoint
2	Current process variable
3	Setpoint slider
4	Process variable indicator
5	Type a value for control variable output (CV1, CV2, CV3).
6	Control variable sliders
7	Manual loop
8	Auto loop

## Maintenance Tab

Maintenance personnel use the information and controls on the Maintenance tab to adjust device parameters, troubleshoot, temporarily work around device problems, and disable the device for routine maintenance. Several features are common to all Add-On Instructions faceplates. See [Basic Faceplate Attributes on page 32](#)



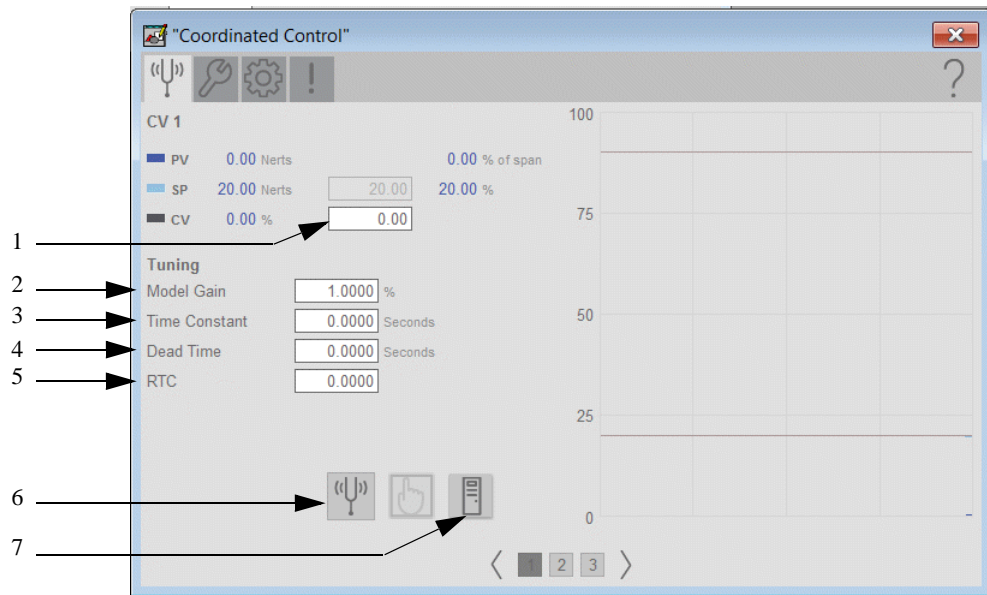
**Table 353 - Maintenance Tab Description**

Item	Description
1	Type the setpoint high threshold.
2	Type the setpoint low threshold.
3	Type the CV high and low, in percent (CV1, CV2, CV3).
4	Type the CV Rate of Change positive limit, in percent per second. (CV1, CV2, CV3). Rate of change limiting is used only when in Auto mode or in Manual mode if CVManLimiting is true. A value of zero disables CV1 ROC limiting.
5	Type the CV Rate of Change negative limit, in percent per second. (CV1, CV2, CV3). Rate of change limiting is used only when in Auto mode or in Manual mode if CVManLimiting is true. A value of zero disables CV1 ROC limiting.

## Advanced Tab

### Tuning

The tuning tab consists of separate pages for each CV. The following example shows page 1. Pages for the additional CV settings have the same setup parameters. Click the page numbers to advance to the next CV.



**Table 354 - Tuning Tab Description**

Item	Description
1	Enter the target value for CV, CV2, or CV3.
2	Enter the CV1, CV2, or CV3 gain.
3	Enter the CV1, CV2, or CV3 time constant.
4	Enter the deadtime for CV1, CV2, or CV3.
5	Enter the CV1, CV2, or CV3 response time constant. This value determines the speed of the CV in seconds.
6	Click to open the CC Autotune (CV1, CV2, or CV3) faceplate. See <a href="#">Coordinated Control (CC) Autotune on page 506</a> .
7	Click to request Auto Loop mode.

Maintenance Tab

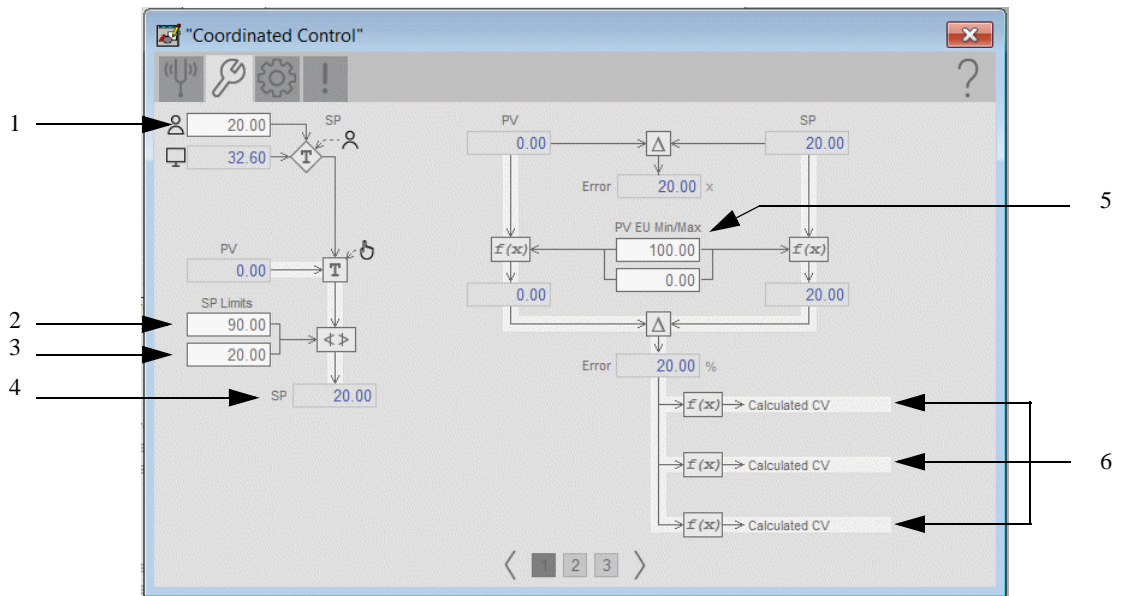
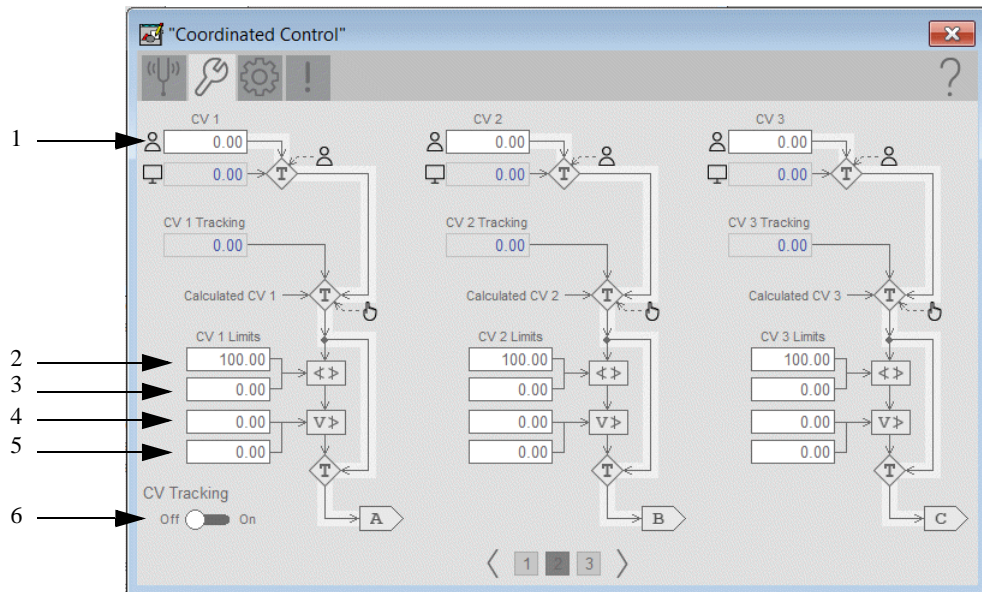


Table 355 - Maintenance Tab Page 1 Description

Item	Description
1	Type the Operator setpoint.
2	Type the maximum limit for the setpoint.
3	Type the minimum limit for the setpoint.
4	Actual Setpoint
5	Type the maximum and minimum limits for the PV in engineering units.
6	Calculated values that are used on the next page.

This example shows the functions for CV1, CV2, and CV3. The functions for CV1 are described. The functions for CV2 and CV3 are the same as CV1.

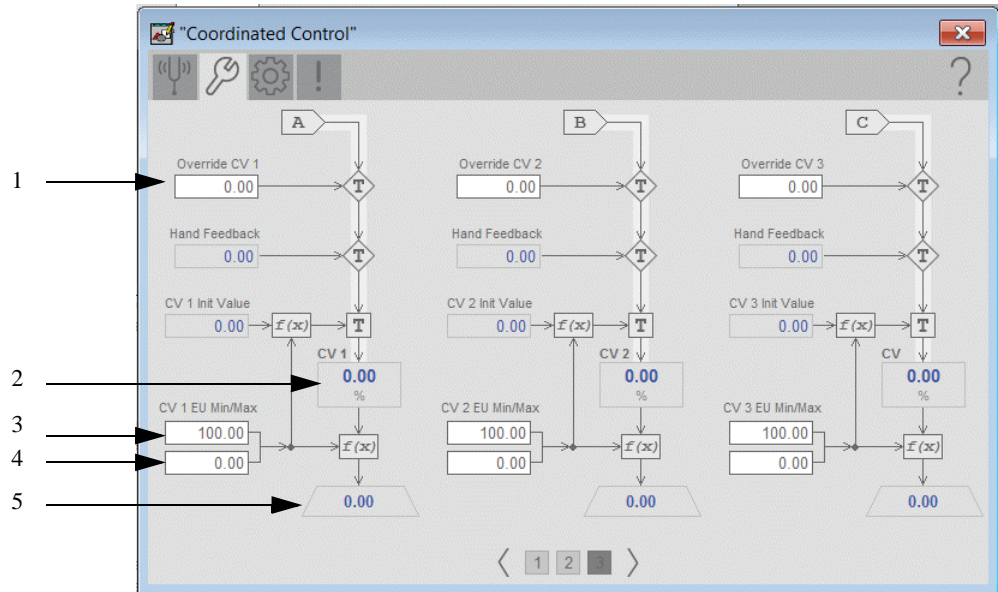


**Table 356 - Maintenance Tab Page 2 Description**

Item	Description
1	Type in the value (%) for CV.
2	Type in the maximum limit for the CV.
3	Type in the minimum limit for the CV.
4	Type in the maximum CV Rate of Increase.
5	Type in the minimum CV Rate of Increase.
6	Turn on to enable CV tracking when autotune is off. This parameter is ignored in Hand and Operator mode.



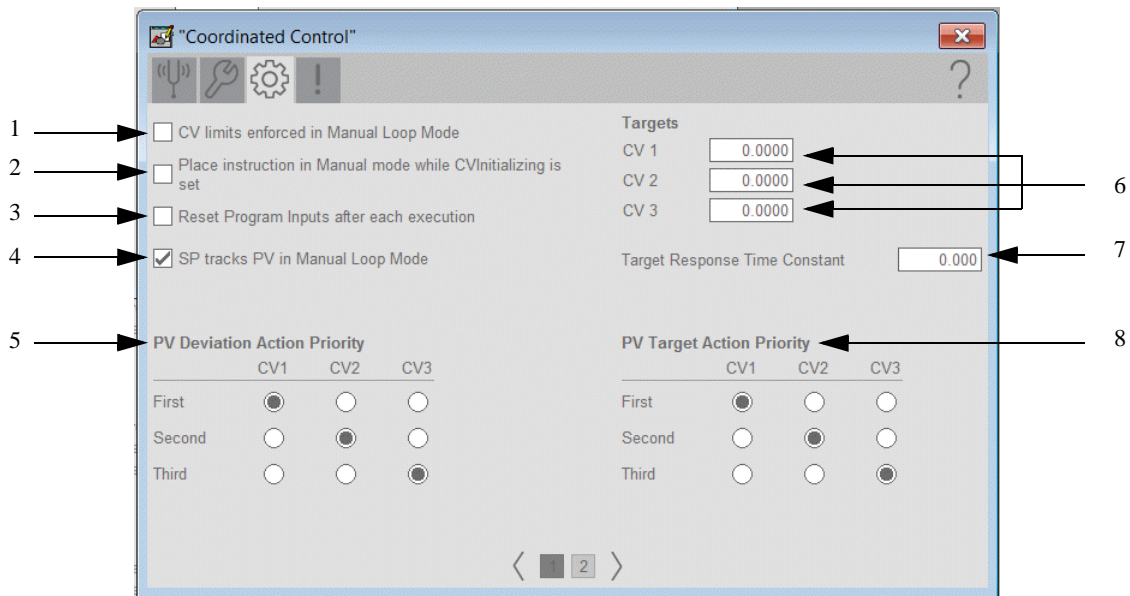
This example shows the functions for CV1, CV2, and CV3. The functions for CV1 are described. The functions for CV2 and CV3 are the same as CV1.



**Table 357 - Maintenance Tab Page 3 Description**

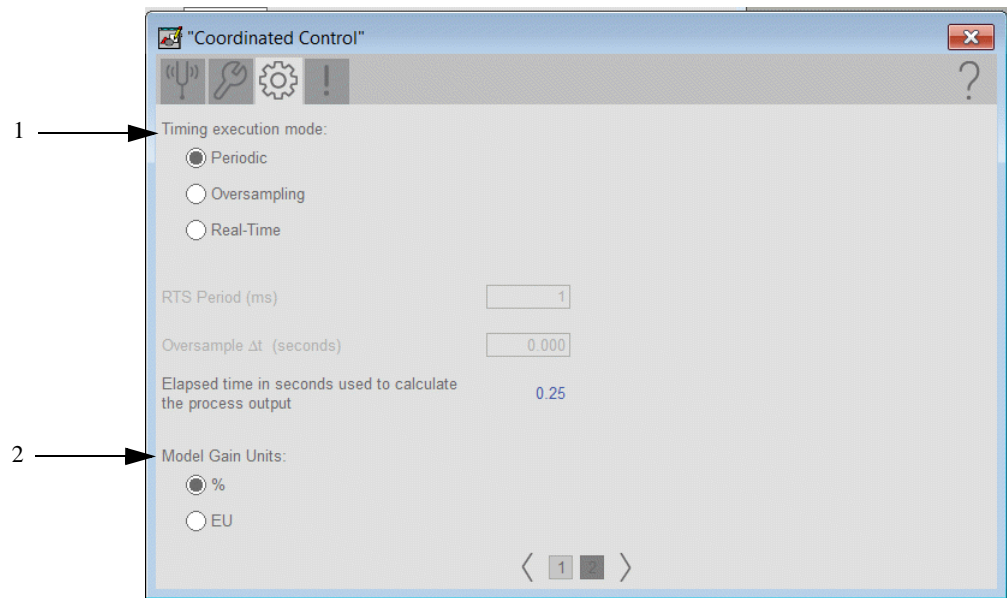
Item	Description
1	Type the CV1, CV2, or CV3 Override value. CV1, CV2, or CV3 is set to this value when in Override mode. This value is recommended to correspond to a safe state output of the loop.
2	CV output %
3	Type the maximum value for CV1EU, CV2EU, or CV3EU. The value of CV1EU, CV2EU, or CV3EU that corresponds to 100% CV1, CV2, or CV3.
4	Type the minimum value for CV1EU, CV2EU, or CV3EU. The value of CV1EU, CV2EU, or CV3EU that corresponds to 0% CV1, CV2, or CV3.
5	Current value (EU)

### Engineering Tab



**Table 358 - Engineering Tab Page 1 Description**

Item	Description
1	Check to limit the current value when in Manual mode.
2	Check to set the Loop mode to manual when CV initialization is requested. Clear the checkbox to leave the Loop mode unchanged when initialization is requested. When the initialization request clears, the loop resumes control in its previous Loop mode.
3	Check to reset Program inputs after each execution.
4	Click to Set <b>true</b> to enable PV Tracking when autotune is OFF. This parameter is ignored in Hand and Override mode.
5	Click to select CV1, CV2, or CV3 to be the first, second, or third to act to compensate for PV-SP deviation.
6	Type the CV1, CV2, or CV3 target value.
7	Type a value for the Target Response Time Constant.
8	Click to set the PV target action priority for CV1, CV2, and CV3.

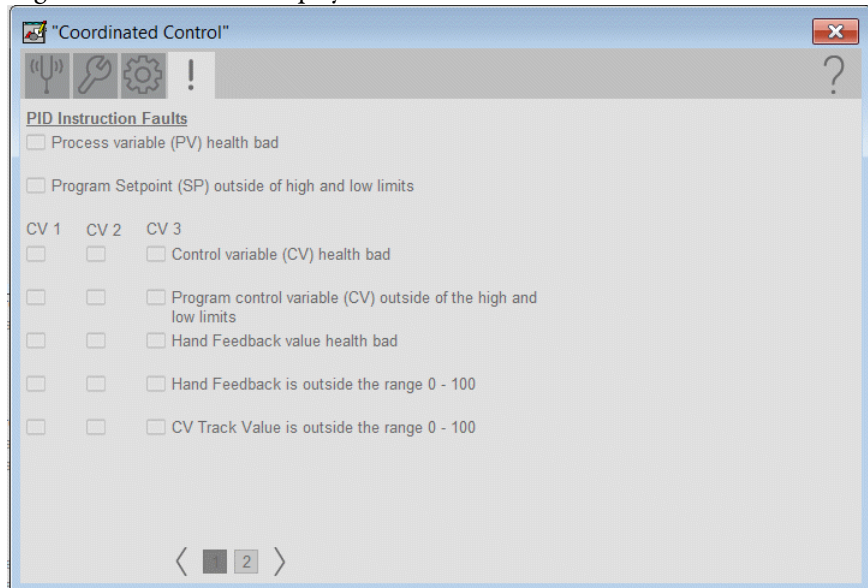


**Table 359 - Engineering Tab Page 2 Description**

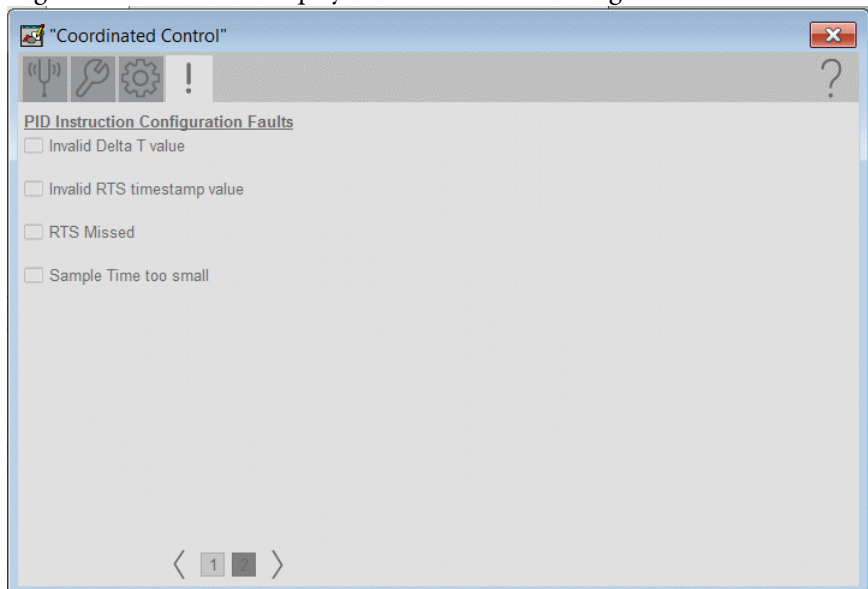
Item	Description
1	Click to select the time base execution mode.
2	Click to select the model gain units. (Percent or Engineering Units)

### Faults Tab

Page 1 of the Faults tab displays PID Instruction faults.

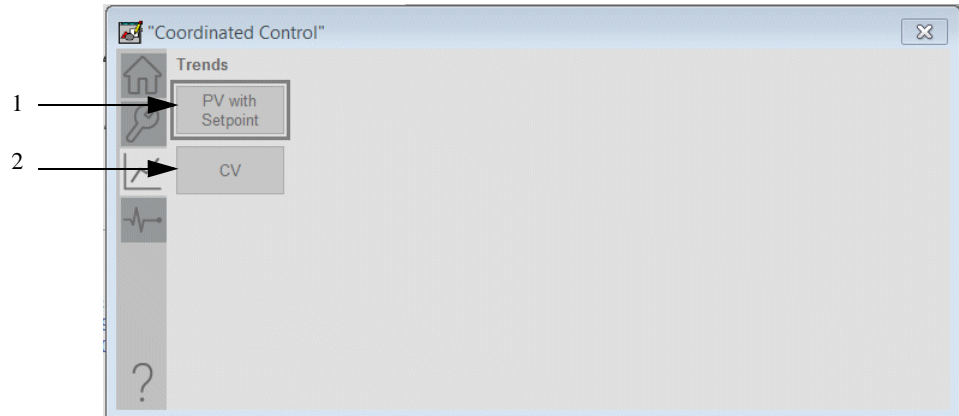


Page 2 of the Faults tab displays PID Instruction Configuration Faults.



## Trends Tab

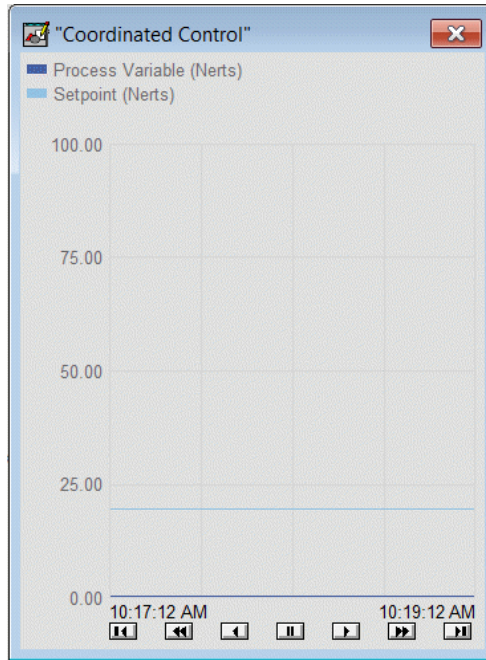
The Trends tab shows trend charts of key device data over time. These faceplate trends provide a quick view of current device performance to supplement, but not replace, dedicated historical or live trend displays. For basic trends tab functionality, See [Trends Display on page 37](#).



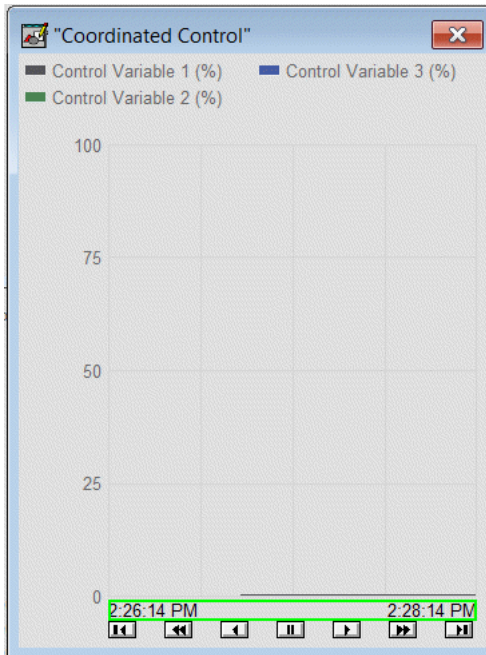
**Table 360 - Trends Tab Description**

Item	Description
1	Click to open the trends for the PV with Setpoint.
2	Click to open the trend tab for the control variables.

*PV with Setpoint Trends Tab*

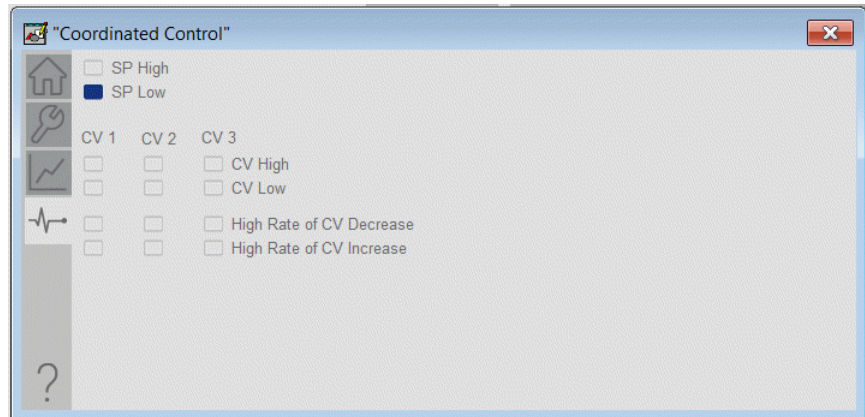


*CV Trends Tab*

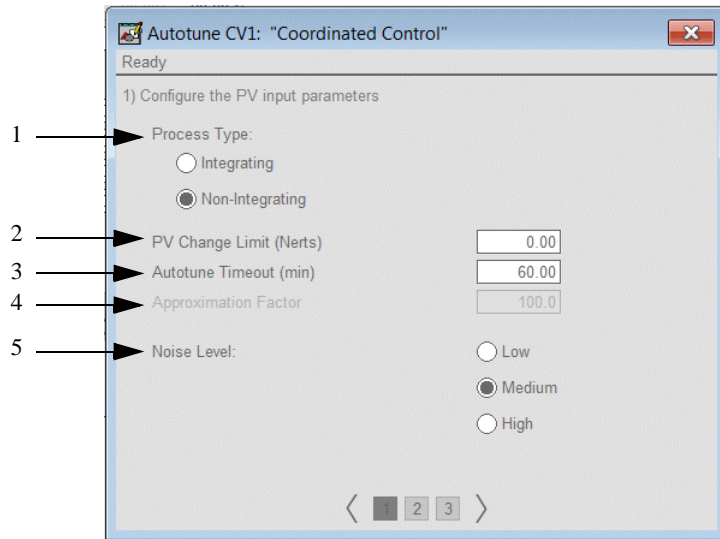


## Diagnostics Tab

The Diagnostic tab provides indications to diagnose device problems. This tab includes device warnings and faults, warning and fault history, and predictive/preventive maintenance data.



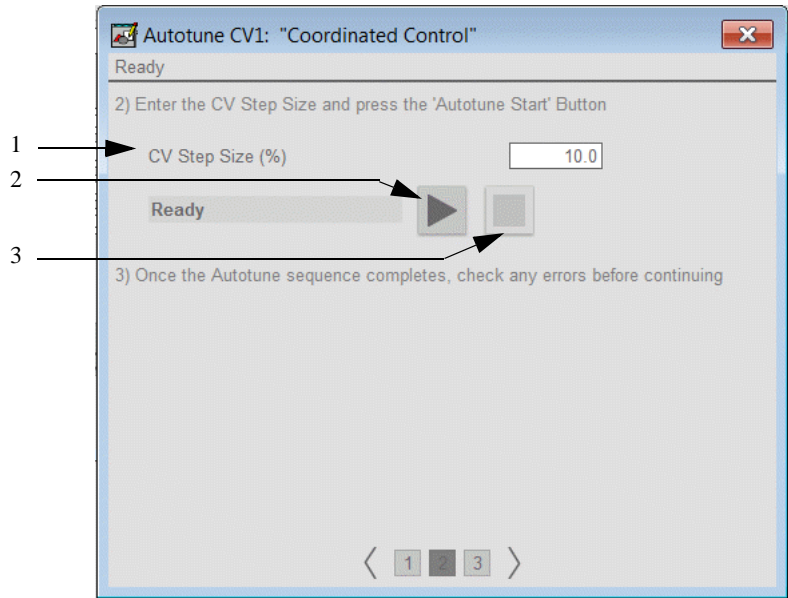
## Coordinated Control (CC) Autotune



**Table 361 - CC Autotune Tab Page 1 Description**

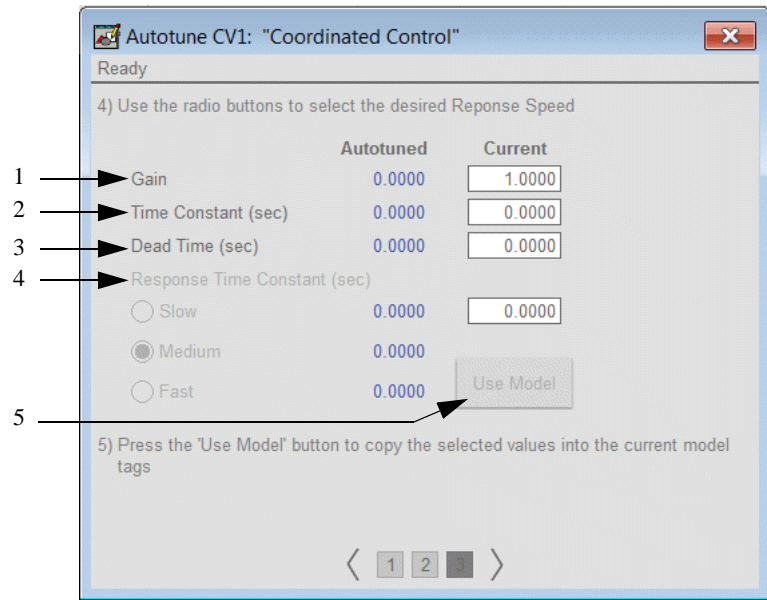
Item	Description
1	Click either Integrating or Non-integrating.
2	Enter the PV change limit.
3	Type a value for the maximum time for autotune to complete following the CV step change. When autotune exceeds this time, tuning is aborted.
4	Type a value for the integrating model approximation factor. <b>IMPORTANT:</b> You can enter this value only when Integrating is selected as the Process Type.
5	Click Low, Medium, or High to set the estimate of the noise level that is expected on the PV to compensate for it during tuning.





**Table 362 - CC Autotune Tab Page 2 Description**

Item	Description
1	Type a value for CV1, CV2, or CV3 step size in percent for the tuning step test.
2	Click to start the autotune process.
3	Click to abort the autotune process. This button also becomes active if the process is aborted due to an error.



**Table 363 - CC Autotune Tab Page 3 Description**

Item	Description
1	Type a value for the gain for CV1, CV2, or CV3. Enter a positive or negative gain depending on process direction.
2	Type a value for CV1, CV2, or CV3 time constant in seconds.
3	Type a value for CV1, CV2, or CV3 deadtime in seconds.
4	Type a value for the tuning parameter that determines the speed of the control variable action for CV1, CV2, or CV3 in seconds.
5	Click to replace the current model parameters with the calculated Autotune model parameters.

## Internal Model Control (IMC)

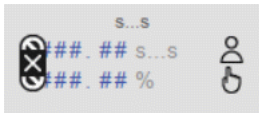
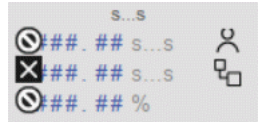
The Internal Model Control (IMC) function block controls one process variable by manipulating one control-variable output. This function block performs an algorithm where the actual error signal is compared against that of an internal first-order lag plus deadtime model of the process. The IMC function block calculates the control variable output (CV) in the Auto mode based on the PV - SP deviation, internal model, and tuning.

This document is for the visualization files, display elements, global objects, and HMI information. The operation of the Add-On Instructions and controller code is contained in publication [PROCES-RM013](#).

### Display Elements

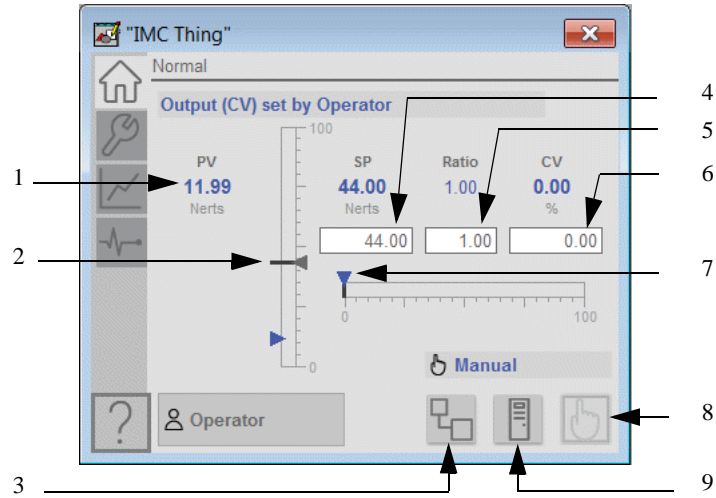
A display element (global object) is created once and can be referenced multiple times on multiple displays in an application. When changes are made to the original (base) object, the instantiated copies (reference objects) are automatically updated. Use of global objects, with tag structures in the ControlLogix system, aid consistency and save engineering time.

**Table 364 - IMC Display Elements Description**

Display Element Name	Display Element	Description
GO_BuiltIn_IMC		Internal Model Control object with a Process Variable and a Control Variable.
GO_BuiltIn_IMC2		Internal Model Control object with a Process Variable, Setpoint, and a Control Variable.

## Operator Tab

The Faceplate initially opens to the Operator (Home) tab. From here, an operator can monitor the device status and manually operate the device when it is in Operator mode. Several features are common to all Add-On Instructions faceplates. See [Basic Faceplate Attributes on page 32](#).

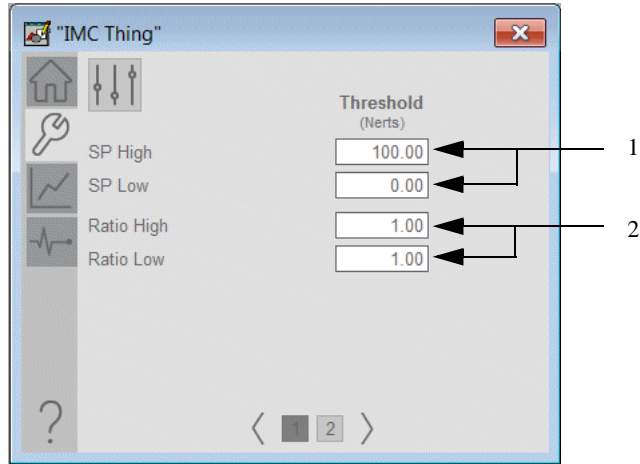


**Table 365 - Operator Tab Description**

Item	Description
1	PV indicator
2	Move this slider to adjust the loop setpoint.
3	Click to request Cascade Loop mode. <b>IMPORTANT:</b> This button is available only if 'Allow Cascade/Ratio Mode' on page 1 of the Engineering tab is checked.
4	Type the SP Operator value, scaled in PV units. SP is set to this value when in Operator control.
5	Type a value for the Ratio Operator multiplier. Ratio is set to this value when in Operator control.
6	Type a value for CV Operator Manual value. CV is set to this value when in Operator control and Manual mode.
7	Move this slider to adjust the loop CV output.
8	Click to request Manual Loop mode.
9	Click to request Auto Loop mode.

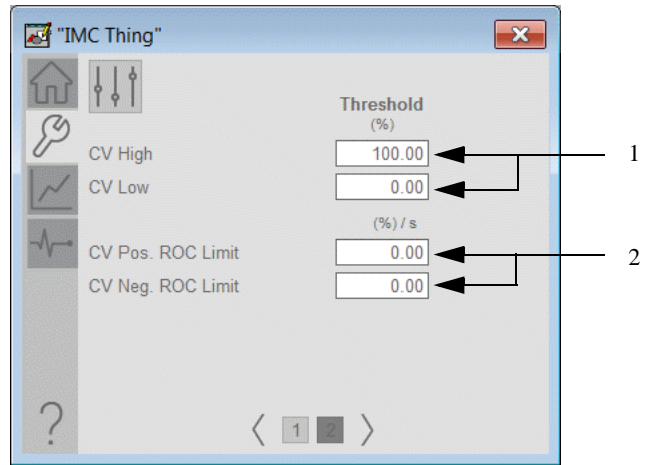
## Maintenance Tab

Maintenance personnel use the information and controls on the Maintenance tab to adjust device parameters, troubleshoot, temporarily work around device problems, and disable the device for routine maintenance. Several features are common to all Add-On Instructions faceplates. See [Basic Faceplate Attributes on page 32](#)



**Table 366 - Maintenance Tab Page 1 Description**

Item	Description
1	Type the SP maximum and minimum limits.
2	Type a value for the Ratio high and low limits. These parameters limit the value of Ratio obtained from RatioProg or RatioOper.

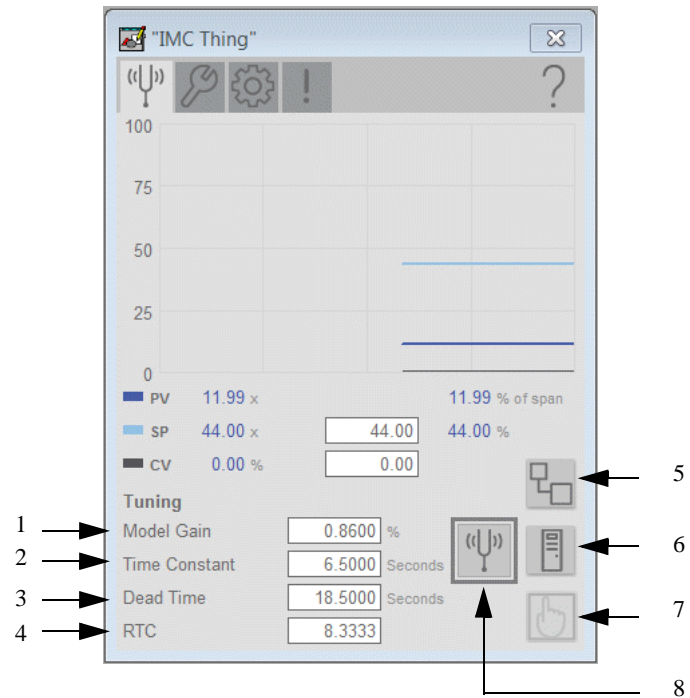


**Table 367 - Maintenance Tab Page 2 Description**

Item	Description
1	Type values for the CV high and low limits. It is also used for limiting CV when in Auto or CascadeRatio modes or Manual mode if CVManLimiting is <b>true</b> .
2	CV increasing or decreasing rate of change limit, in percent per second. The rate of change limiting is used only when in Auto or CascadeRatio modes or Manual mode if CVManLimiting is <b>true</b> . A value of zero disables CV ROC limiting.

## Advanced Tab

### Tuning



**Table 368 - Tuning Tab Description**

Item	Description
1	Type a value for the internal model gain. Enter a positive or negative gain depending on process direction.
2	Type a value for the internal model Time Constant in seconds.
3	Type a value for the internal model Deadtime in seconds.
4	Type a value for the tuning parameter that determines the speed of the control variable action in seconds.
5	Click to request Cascade Loop mode.
6	Click to request Auto Loop mode.
7	Click to request Manual Loop mode.
8	Click to open the CV Autotune faceplate.

Maintenance Tab

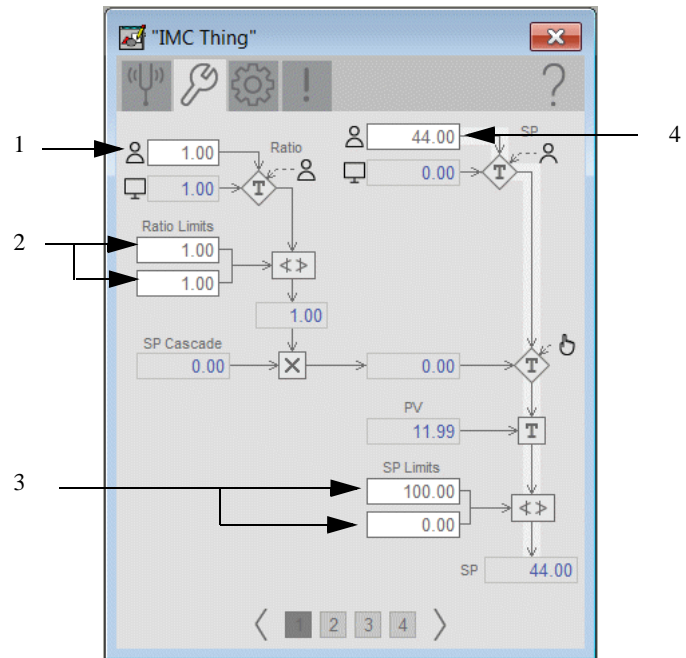
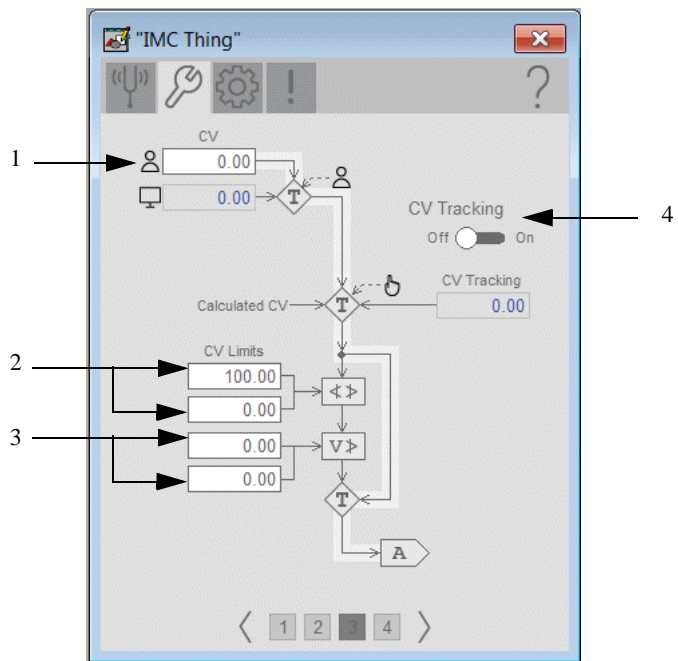


Table 369 - Advanced Maintenance Tab Page 1 Description

Item	Description
1	Type a value for the Ratio Operator multiplier. Ratio is set to this value when in Operator control.
2	Type a value for the Ratio high and low limits. These parameters limit the value of Ratio obtained from RatioProg or RatioOper.
3	Type the SP maximum and minimum limits.
4	Type a value for the SP Operator value, scaled in PV units. SP is set to this value when in Operator control.

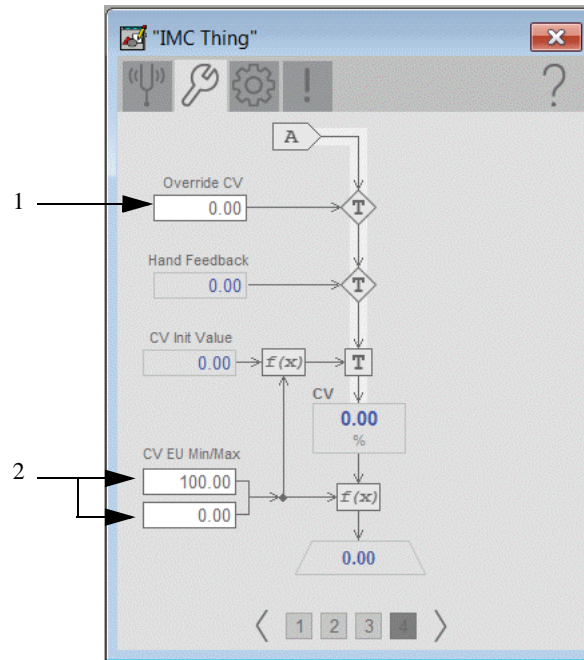






**Table 371 - Advanced Maintenance Tab Page 3 Description**

Item	Description
1	Type the operator CV value.
2	Type values for the CV high and low limits. It is also used for limiting CV when in Auto or CascadeRatio modes or Manual mode if CVManLimiting is <b>true</b> .
3	CV increasing or decreasing rate of change limit, in percent per second. The rate of change limiting is used only when in Auto or CascadeRatio modes or Manual mode if CVManLimiting is <b>true</b> . A value of zero disables CV ROC limiting.
4	Check to enable CV Tracking when autotune is OFF. This parameter is ignored in Hand and Override mode.



**Table 372 - Advanced Maintenance Tab Page 4 Description**

Item	Description
1	Type the value for the CV Override value. CV is set to this value when in Override mode.
2	Type the maximum or minimum value for CV EU scaling. This value corresponds to 100% or 0% CV respectively.

Engineering

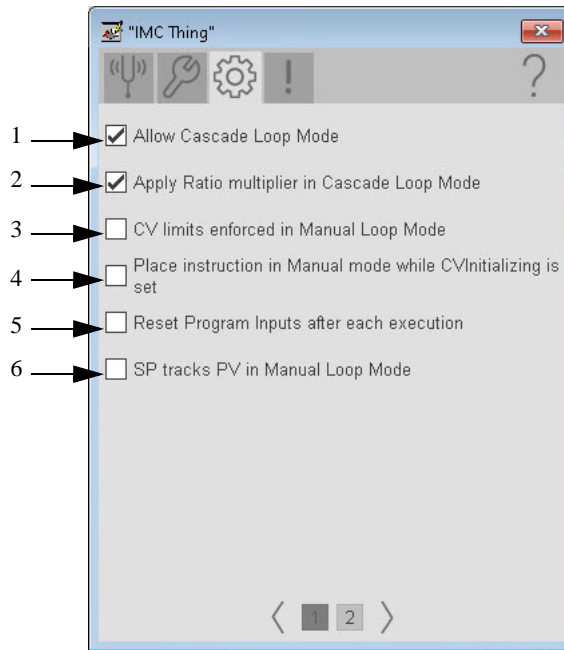
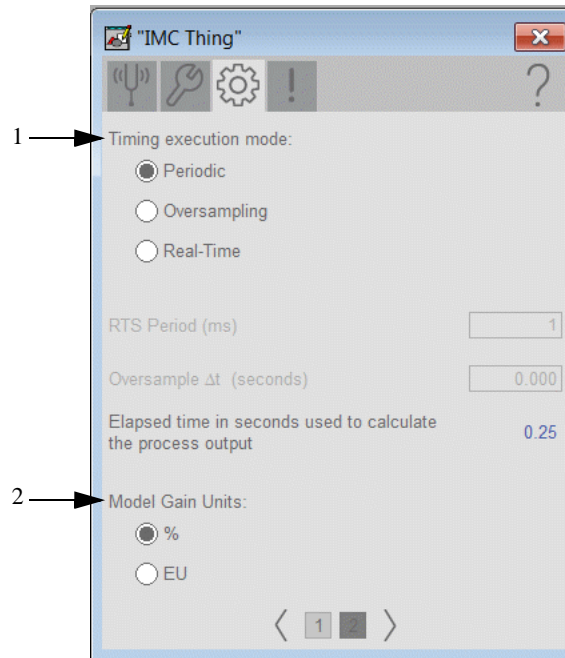


Table 373 - Engineering Tab Page 1 Description

Item	Description
1	Check if Cascade Loop mode is to be used. <b>IMPORTANT:</b> Checking this option displays the Cascade button on the Operator tab.
2	Check to enable ratio control when in Cascade Loop mode. <b>IMPORTANT:</b> Checking this option displays the current ratio multiplier, Operator ratio multiplier, and Program ratio multiplier on the Operator tab. Checking this option also displays the Cascade/Ratio portion of the SAMA diagram on page 1 of the Maintenance tab.
3	Check to limit the CV while in Manual mode.
4	Check to set the Loop mode to manual when CV initialization is requested. Clear the checkbox to leave the Loop mode unchanged when initialization is requested. When the initialization request clears, the loop resumes control in its previous Loop mode.
5	Check to reset Program inputs after each execution.
6	Click to enable PV Tracking when autotune is OFF. This parameter is ignored in Hand and Override mode.

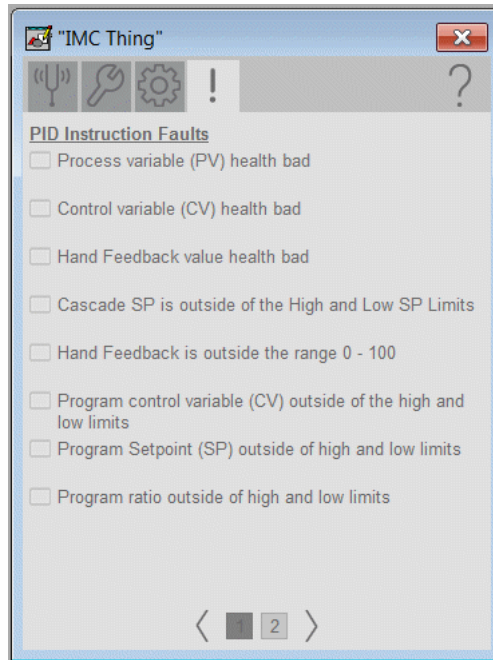


**Table 374 - Engineering Tab Page 2 Description**

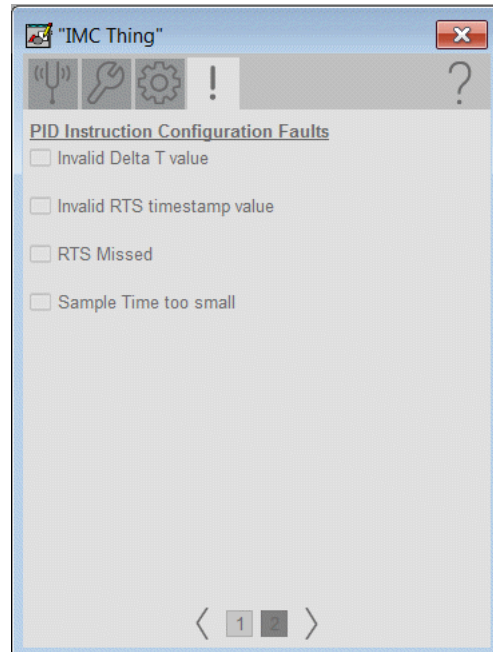
Item	Description
1	Click to select the time base execution mode.
2	Click to choose the model gain units. (Percent or Engineering Units)

### Faults Tab

Page 1 of the Diagnostics tab displays PID Instruction faults.

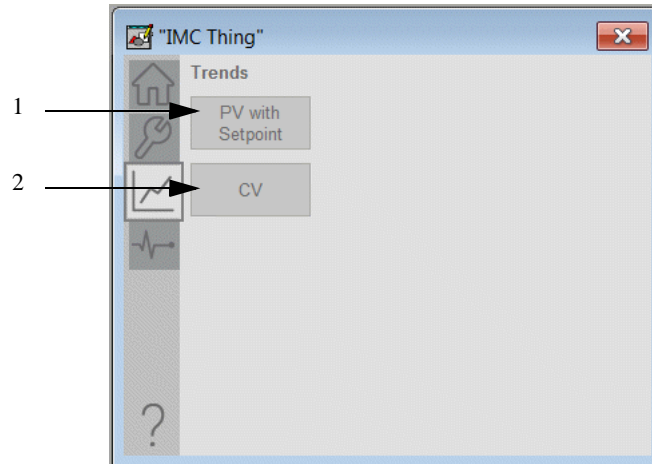


Page 2 of the Diagnostics tab displays PID Instruction Configuration faults.



## Trends Tab

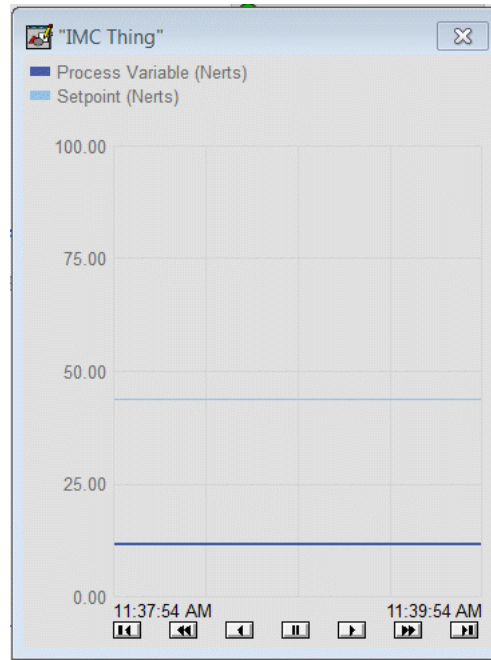
The Trends tab shows trend charts of key device data over time. These faceplate trends provide a quick view of current device performance to supplement, but not replace, dedicated historical or live trend displays. For basic trends tab functionality, See [Trends Display on page 37](#).



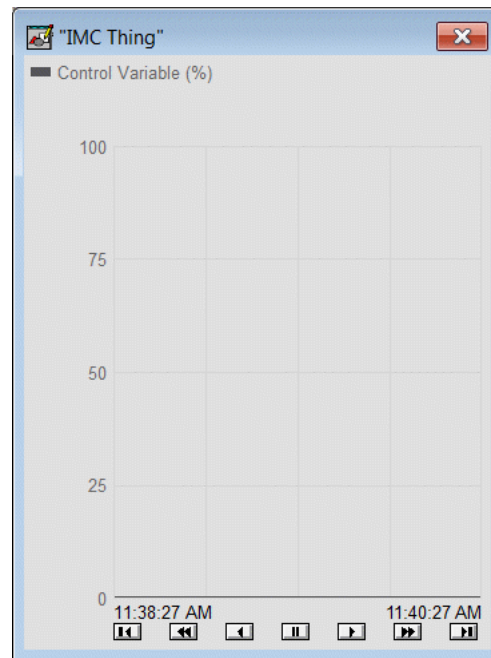
**Table 375 - Trends Tab Description**

Item	Description
1	Click to open the trends for the PV with Setpoint.
2	Click to open the trend tab for the control variables.

### PV with Setpoint Trends Tab



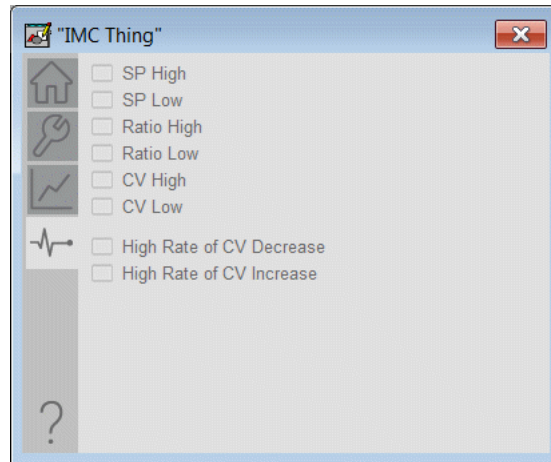
### CV Trends Tab





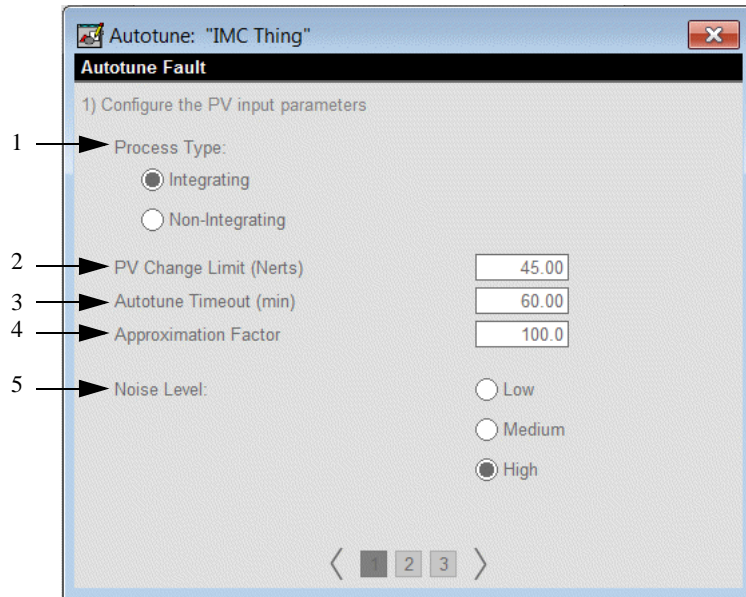
## Diagnostics Tab

The Diagnostic tab provides indications to diagnose device problems. This tab includes device warnings and faults, warning and fault history, and predictive/preventive maintenance data.



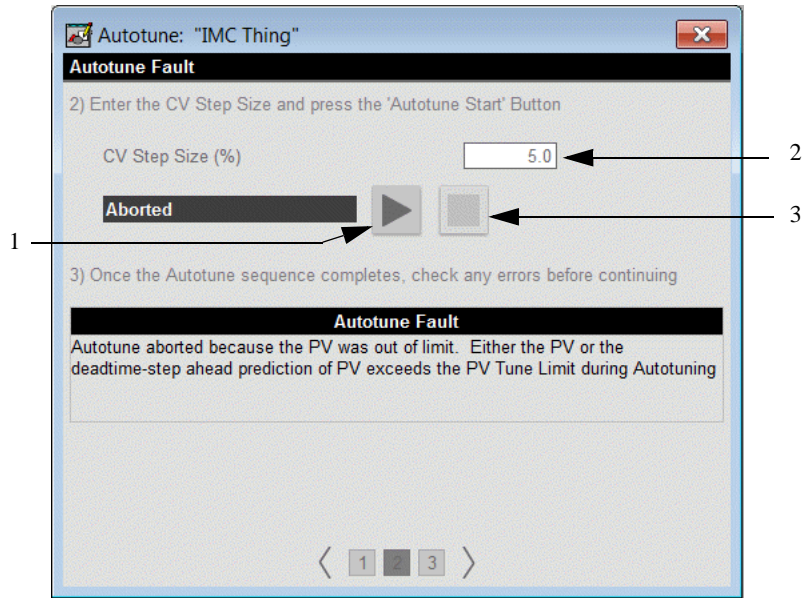
## Internal Model Control (IMC) Autotune

The faceplates in this section let you access all necessary parameters to autotune the IMC function block and hand-tune the instruction.



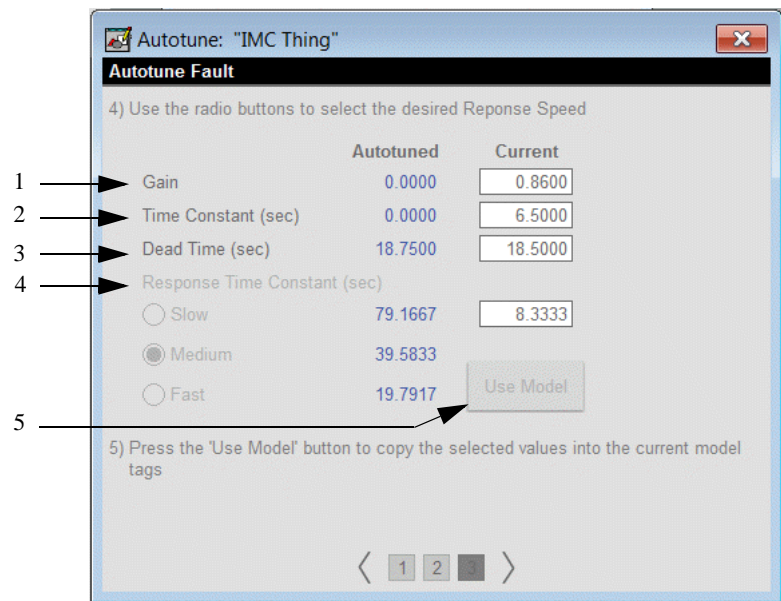
**Table 376 - IMC Autotune Tab Page 1 Description**

Item	Description
1	Click either Integrating or Non-integrating.
2	Type a value for the PV limit scaled in PV units. When Autotune is running and predicted PV exceeds this limit, the tuning is aborted.
3	Type a value for the maximum time for autotune to complete following the CV step change. When autotune exceeds this time, tuning is aborted.
4	Type a value for the non-integrating model approximation factor. <b>IMPORTANT:</b> You can enter this value only when Integrating is selected as the Process Type.
5	Click Low, Medium, or High to set the estimate of the noise level expected on the PV to compensate for it during tuning.



**Table 377 - IMC Autotune Tab Page 2 Description**

Item	Description
1	Click to start the autotune process.
2	Type a value for CV1, CV2, or CV3 step size in percent for the tuning step test.
3	Click to abort the autotune process. This button also becomes active if the process is aborted due to an error.



**Table 378 - IMC Autotune Tab Page 3 Description**

Item	Description
1	Type a value for the internal model gain for CV1, CV2, or CV3. Enter a positive or negative gain depending on process direction.
2	Type a value for CV1, CV2, or CV3 internal model time constant in seconds.
3	Type a value for CV1, CV2, or CV3 internal model deadtime in seconds.
4	Type a value for the tuning parameter that determines the speed of the control variable action for CV1, CV2, or CV3 in seconds
5	Click to replace the current model parameters with the calculated Autotune model parameters.

## Modular Multivariable Control (MMC)

The Modular Multivariable Control (MMC) function block controls two process variables to their setpoints manipulating up to three control variables. The MMC function block calculates the control variables (CV1, CV2, and CV3) in the Auto mode based on the PV1 - SP1, PV2 - SP2 deviation, internal model, and tuning. The MMC function block is a flexible model-based algorithm that can be used in two basic configuration modes:

- Three control variables used to control two interacting process variables
- Two control variables used to control two interacting process variables

This document is for the visualization files, display elements, global objects, and HMI information. The operation of the Add-On Instructions and controller code is contained in publication [PROCES-RM013](#).

### Display Elements

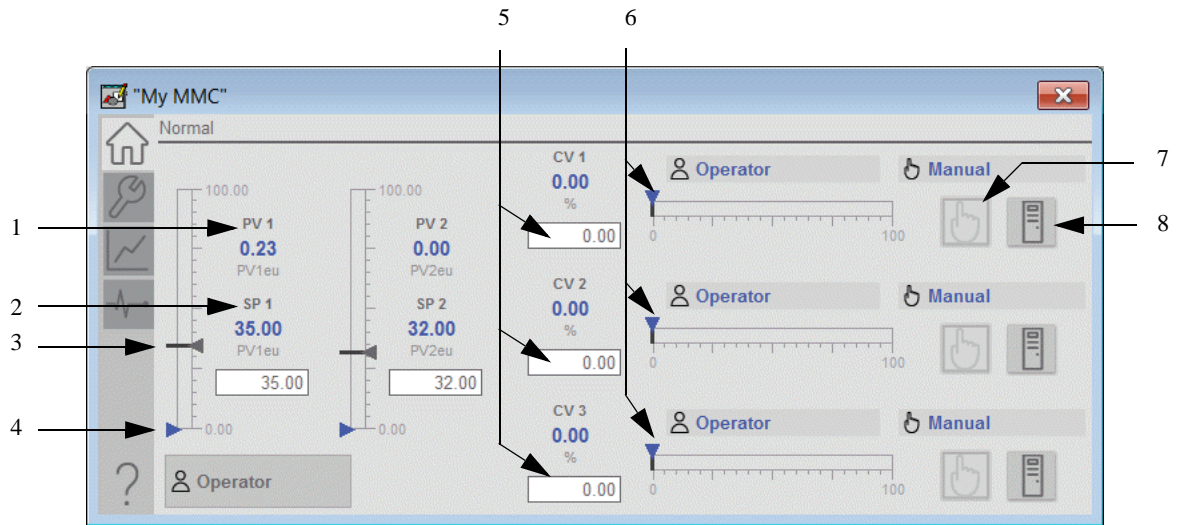
A display element (global object) is created once and can be referenced multiple times on multiple displays in an application. When changes are made to the original (base) object, the instantiated copies (reference objects) are automatically updated. Use of global objects, with tag structures in the ControlLogix system, aid consistency and save engineering time.

**Table 379 - MMC Display Elements Description**

Display Element Name	Display Element	Description
GO_BuiltIn_MMC	<p>The screenshot shows a control panel with a title 's...s'. It contains two rows of process variables: '1###. ## s...s' and '2###. ## s...s'. Below these are three rows of control variables: '1###. ## %', '2###. ## %', and '3###. ## %'. Each row includes a circular icon with an 'X' and a hand icon.</p>	Modular Multivariable Control object with two process variables and three control variables.
GO_BuiltIn_MMC1	<p>The screenshot shows a control panel with a title 's...s'. It contains two rows of process variables: '1###. ## s...s' and '2###. ## s...s'. Below these are two rows of setpoints: '1###. ## s...s' and '2###. ## s...s'. At the bottom are three rows of control variables: '1###. ## %', '2###. ## %', and '3###. ## %'. Each row includes a circular icon with an 'X' and a hand icon.</p>	Modular Multivariable Control object with two process variables, two setpoints, and three control variables.
GO_BuiltIn_MMC2	<p>The screenshot shows a control panel with a title 's...s'. It contains two rows of process variables: '1###. ## s...s' and '2###. ## s...s'. Below these are two rows of setpoints: '1###. ## s...s' and '2###. ## s...s'. Each row includes a circular icon with an 'X' and a hand icon.</p>	Modular Multivariable Control object with two process variables and two setpoints.

## Operator Tab

The Faceplate initially opens to the Operator (Home) tab. From here, an operator can monitor the device status and manually operate the device when it is in Operator mode. Several features are common to all Add-On Instructions faceplates. See [Basic Faceplate Attributes on page 32](#).

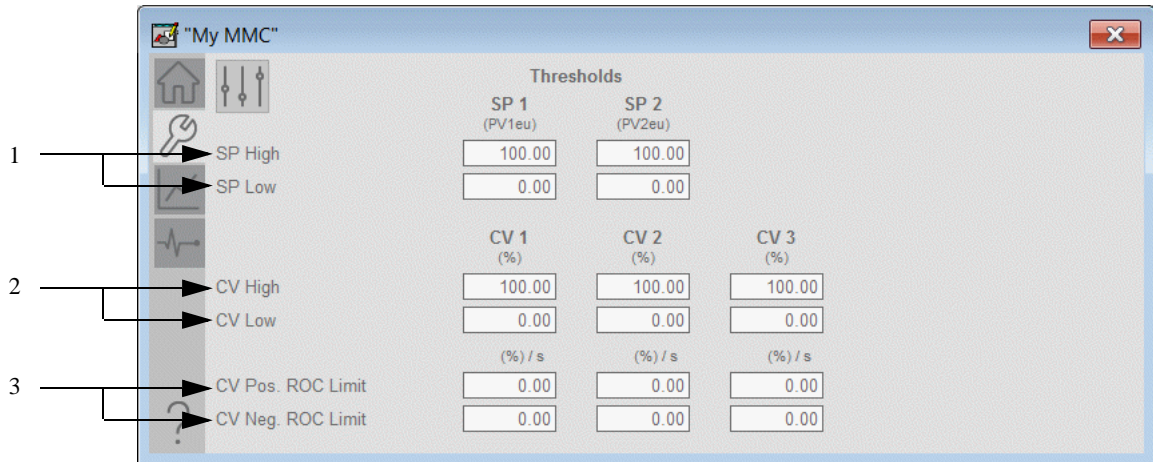


**Table 380 - Operator Tab Description**

Item	Description
1	Current PV value
2	Current SP value
3	Setpoint Slider
4	PV Indicator
5	Operator CV Value
6	CV Slider
7	Click to request Manual Loop mode.
8	Click to request Auto Loop mode.

## Maintenance Tab

Maintenance personnel use the information and controls on the Maintenance tab to adjust device parameters, troubleshoot, temporarily work around device problems, and disable the device for routine maintenance. Several features are common to all Add-On Instructions faceplates. See [Basic Faceplate Attributes on page 32](#)



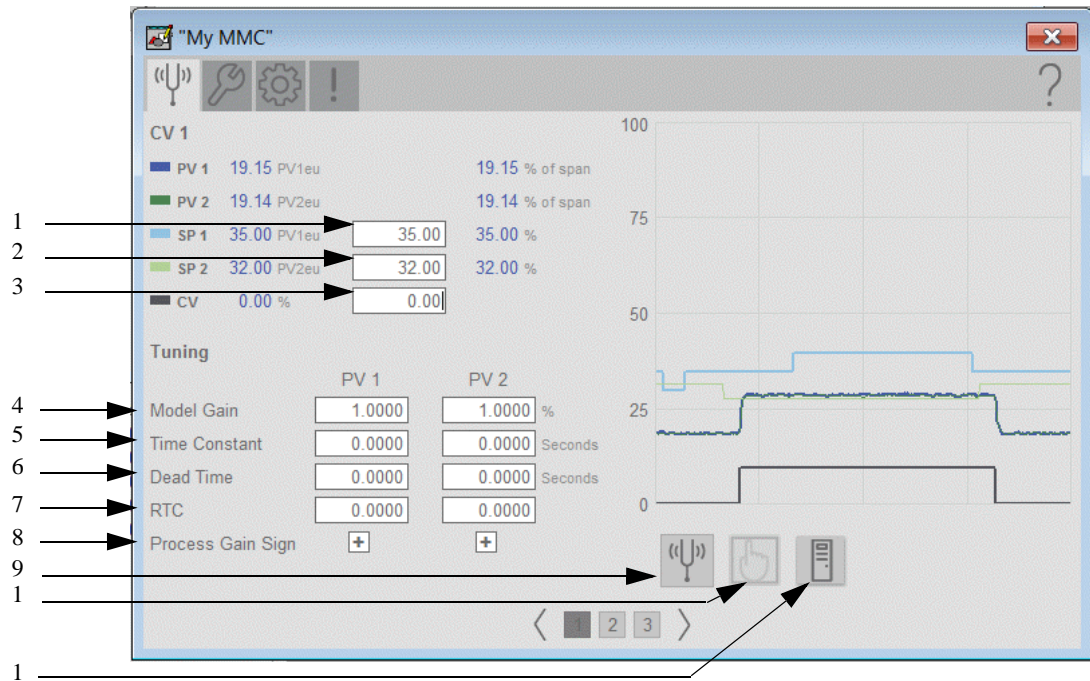
**Table 381 - Maintenance Tab Description**

Item	Description
1	Type the high and low SP threshold.
2	Type the high and low CV threshold.
3	Type the positive and negative Rate of Change limit value. Rate of change limiting is used only when in Auto mode or in Manual mode if CVManLimiting is <b>true</b> . A value of zero disables CV1 ROC limiting.

## Advanced Tab

### Tuning

The following diagram shows the functions for CV1 on page 1. CV2 and CV3 are covered on pages 2 and 3.



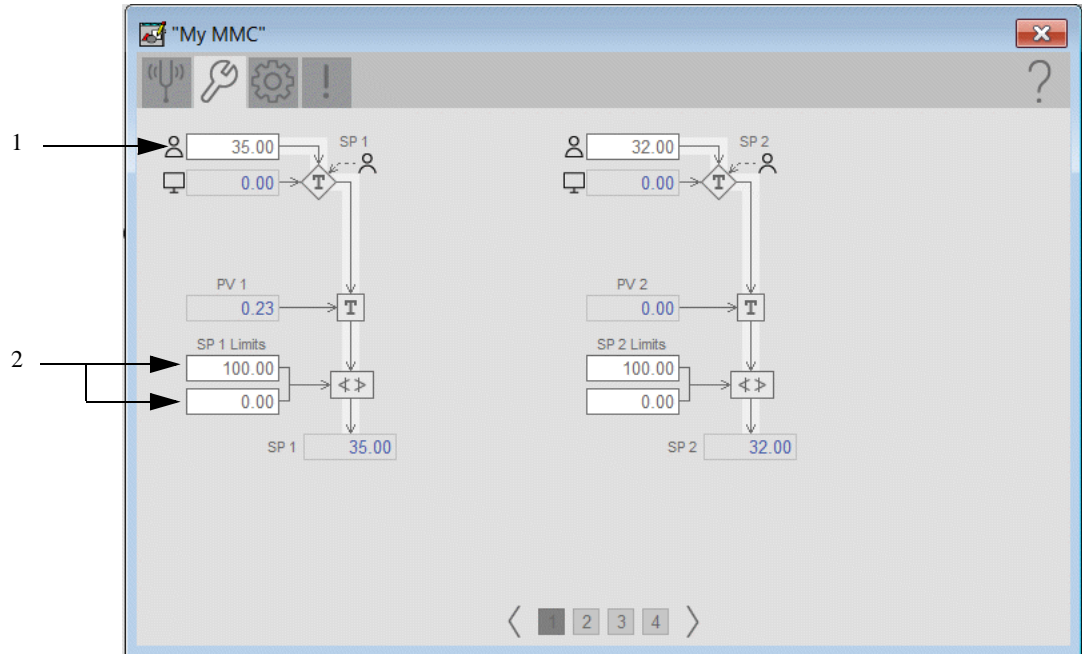
**Table 382 - Tuning Tab Description**

Item	Description
1	Type the SP 1 value.
2	Type the SP2 value.
3	Type the CV value.
4	Type the Operator model gain for PV1: CV1, CV2, or CV3, PV2: CV1, CV2, or CV3. This value is the internal model gain for CV# - PV#. enter a positive or negative gain depending on the process direction.
5	Type the internal model time constant for PV1: CV1, CV2, or CV3, PV2: CV1, CV2, or CV3 in seconds.
6	Type the internal model deadtime for PV1: CV1, CV2, or CV3, PV2: CV1, CV2, or CV3 in seconds.
7	Type the internal Response time constant for PV1: CV1, CV2, or CV3, PV2: CV1, CV2, or CV3. This value is the tuning parameter that determines the speed of the control variable action for CV# - PV# in seconds.
8	Click to select '+' or '-' as the Process Gain sign for PV1: CV1, CV2, or CV3, PV2: CV1, CV2, or CV3. This selection is used only for Autotune and is the sign of the process gain ( $\Delta PV1/\Delta CV1$ ).



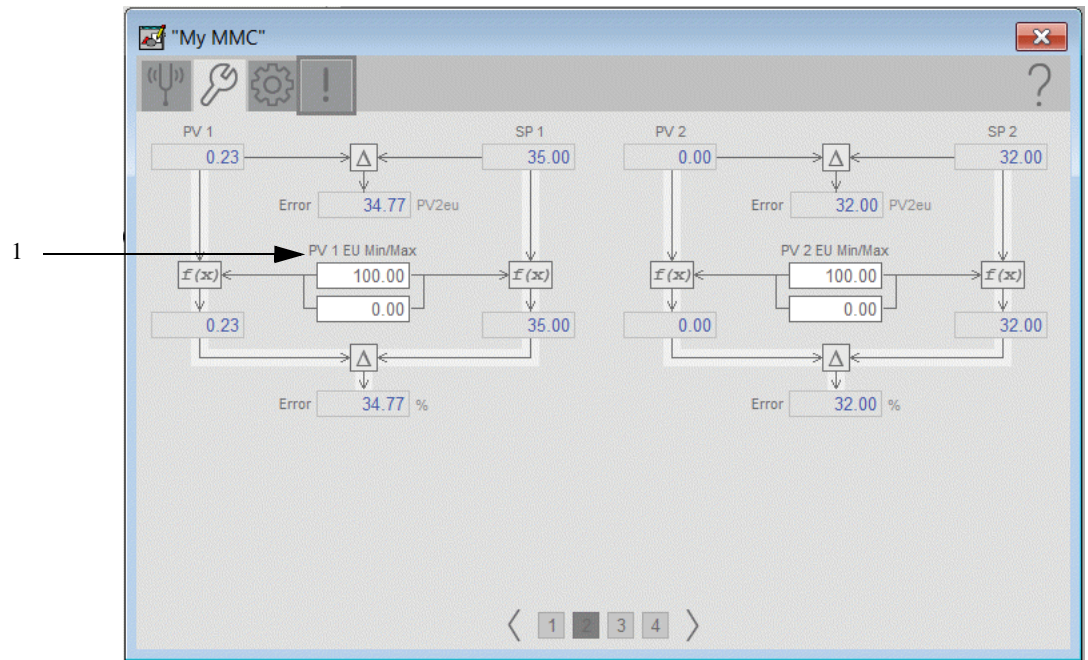
Item	Description
9	Click to show the Autotune (CV1, CV2, or CV3) Operator faceplate.
10	Click to request Manual loop mode.
11	Click to request Auto Loop mode.

*Maintenance Tab*



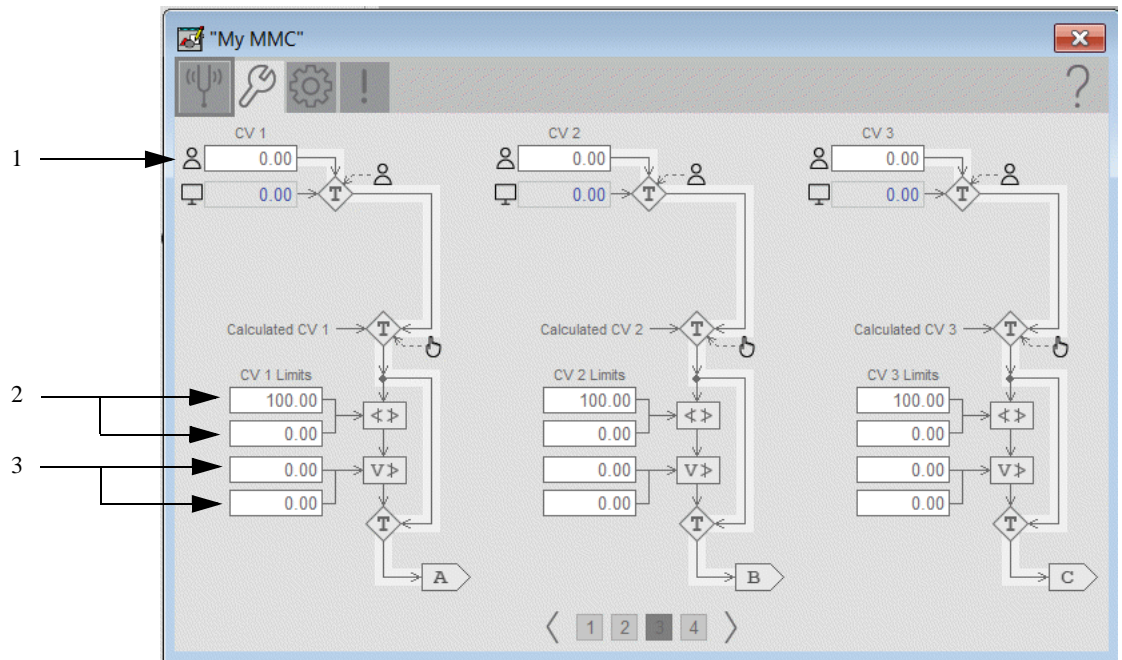
**Table 383 - Advanced Maintenance Tab Page 1 Description**

Item	Description
1	Type the Operator setpoint.
2	Type the high and low limits for the SP.



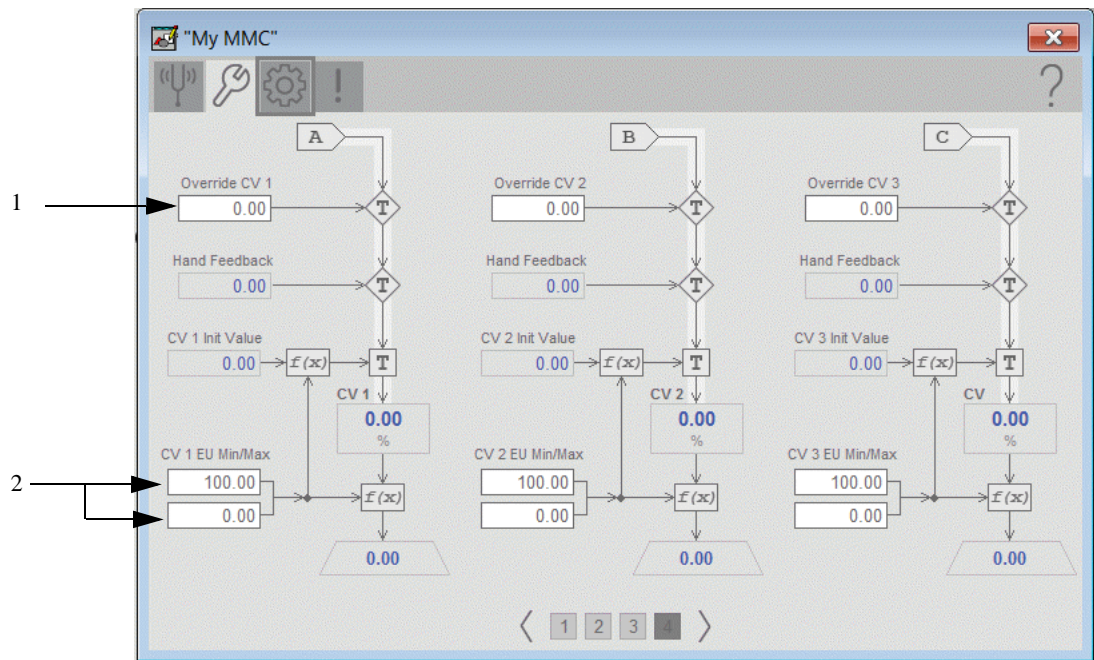
**Table 384 - Advanced Maintenance Tab Page 2 Description**

Item	Description
1	Type the minimum and maximum PV configuration. (In engineering units.)



**Table 385 - Advanced Maintenance Tab Page 3 Description**

Item	Description
1	Type the Operator CV value.
2	Type the CV high and CV low limits.
3	Type the maximum CV rate of increase and decrease configuration values.



**Table 386 - Advanced Maintenance Tab Page 4 Description**

Item	Description
1	Type the override value for the CV. The CV is set to this value when in the Override mode.
2	Type the CV maximum and minimum values in engineering units.

Engineering Tab

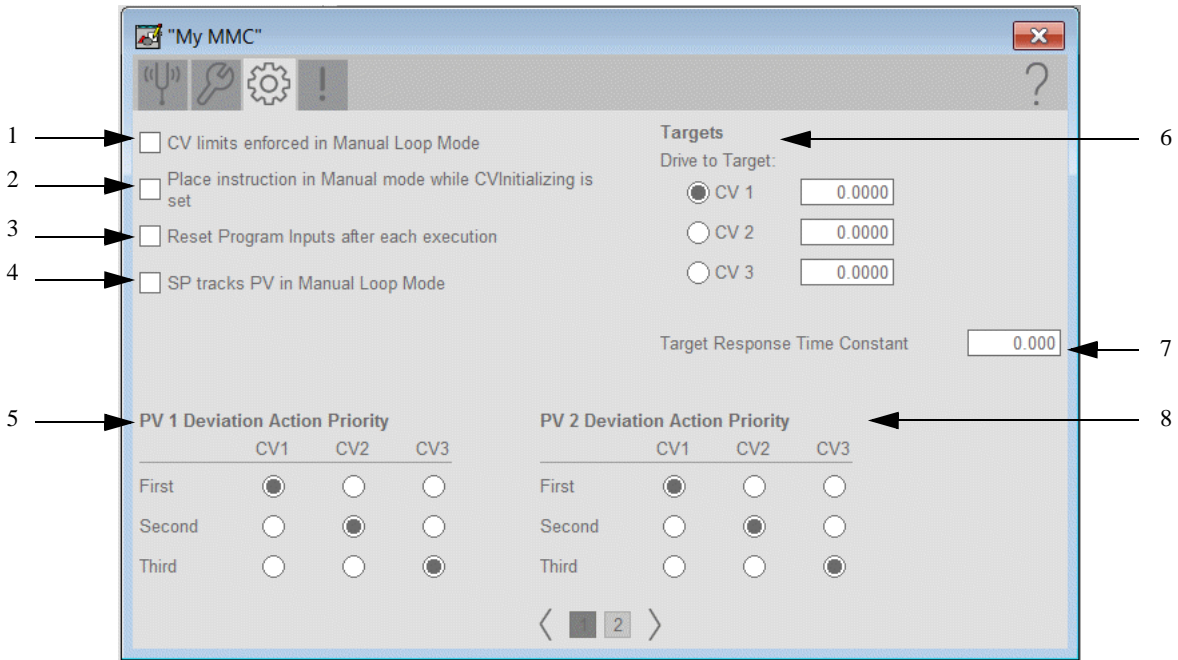
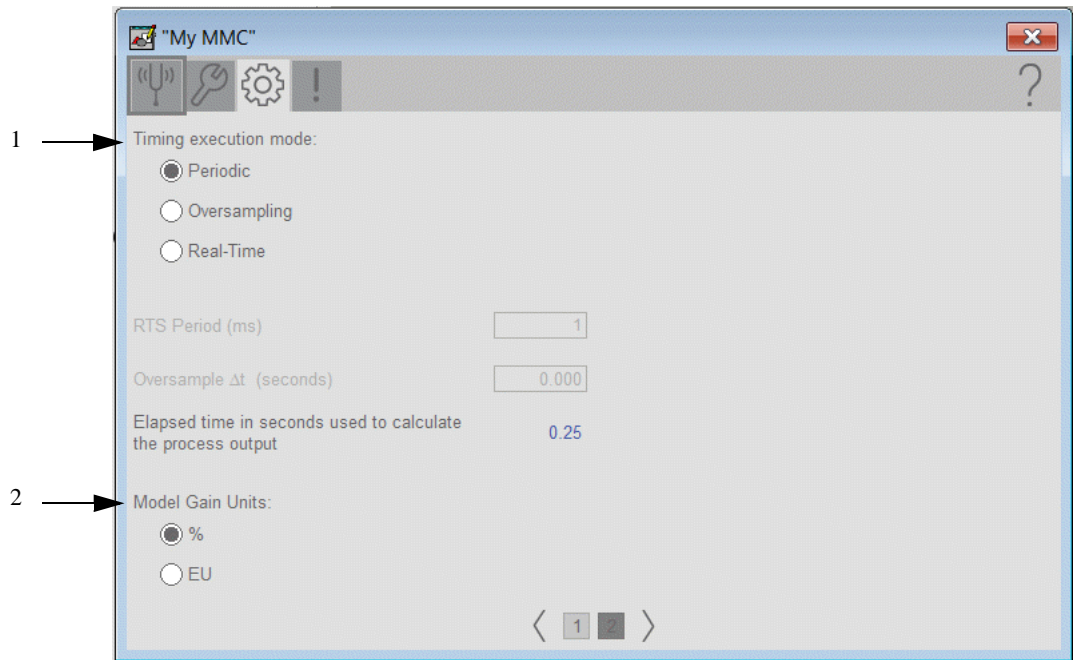


Table 387 - Engineering Tab Page 1 Description

Item	Description
1	Limit CV1, CV2, or CV3 in Manual mode. If in Manual mode and CVManLimiting is <b>true</b> , CV1, CV2, and CV3 are limited by the CV1, CV2, and CV3 HLimit and CV1, CV2, and CV3 LLimit values.
2	Check to set the Loop mode to manual when CV initialization is requested. Clear the checkbox to leave the Loop mode unchanged when initialization is requested. When the initialization request clears, the loop resumes control in its previous Loop mode.
3	Check to reset Program control values after each execution.
4	Check to enable SP to track PV. This process is ignored when in Auto modes. SP tracks PV only when all three outputs are in manual. As soon as any output returns to Auto, PVTracking stops.
5	Click to select the first CV to act to compensate for PV1-SP1 deviation. Click to select the second CV to act to compensate for PV1-SP1 deviation. Click to select the third CV to act to compensate for PV1-SP1 deviation.
6	Click to select the CV to be driven to its target.
7	Type the value that determines the speed with which the control variables approach their target values.
8	Click to select the first CV to act to compensate for PV2-SP2 deviation. Click to select the second CV to act to compensate for PV2-SP2 deviation. Click to select the third CV to act to compensate for PV2-SP2 deviation.

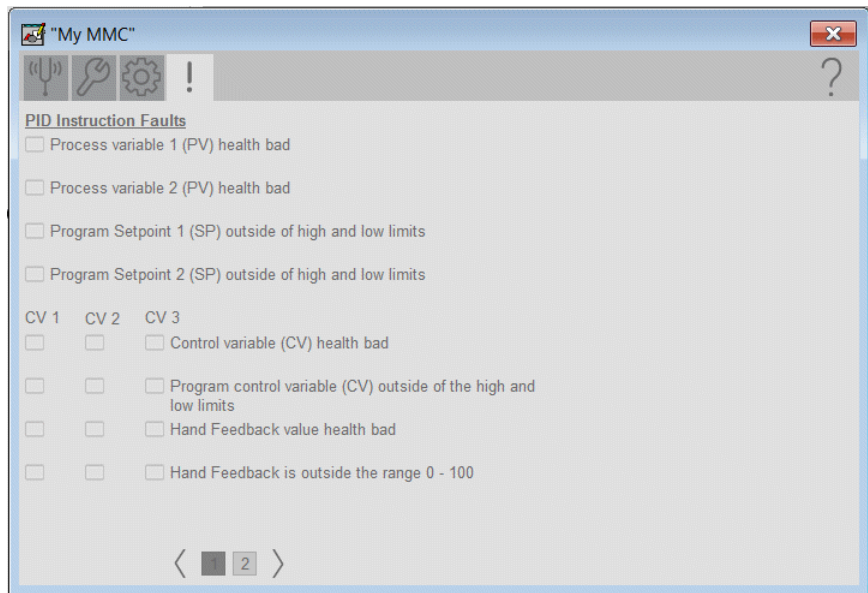


**Table 388 - Engineering Tab Page 1 Description**

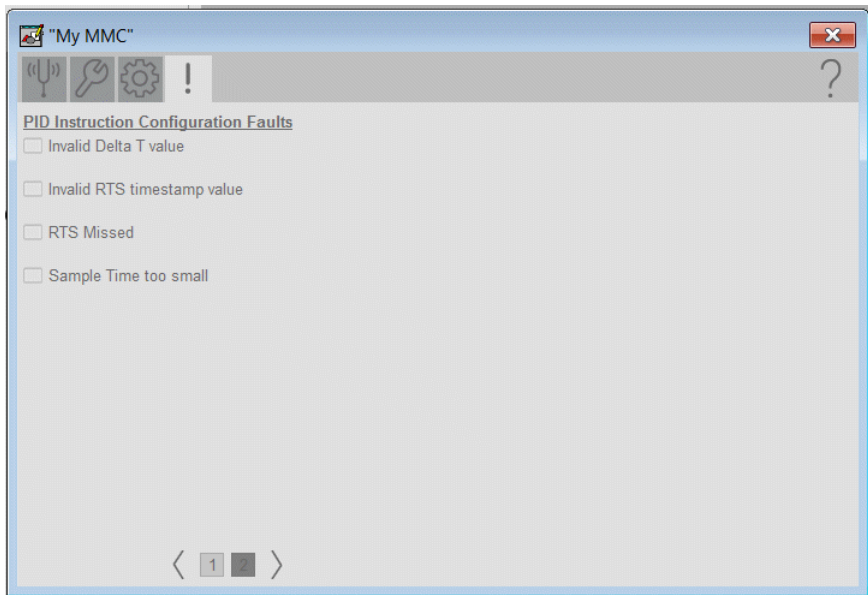
Item	Description
1	Click to select Periodic, Oversampling, or Real-Time for the execution mode.
2	Select either 'EU' or '%' for the Model Gain units in Engineering Units or 'Percent of span'.

## Faults

Page 1 of the Diagnostics tab displays PID Instruction faults.

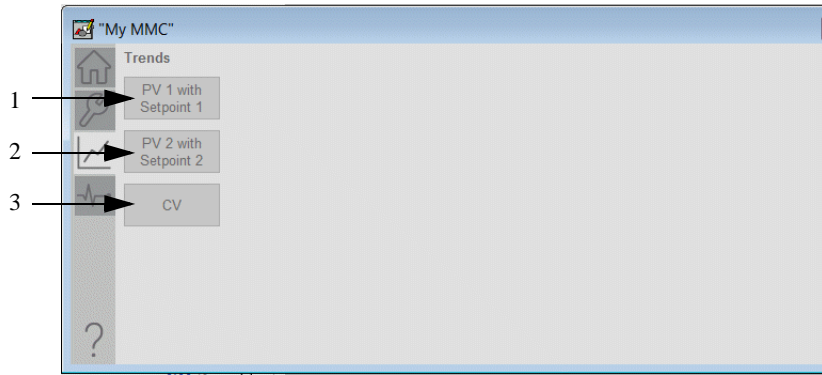


Page 2 of the Diagnostics tab displays PID Instruction configuration faults.



## Trends Tab

The Trends tab shows trend charts of key device data over time. These faceplate trends provide a quick view of current device performance to supplement, but not replace, dedicated historical or live trend displays. For basic trends tab functionality, See [Trends Display on page 37](#).

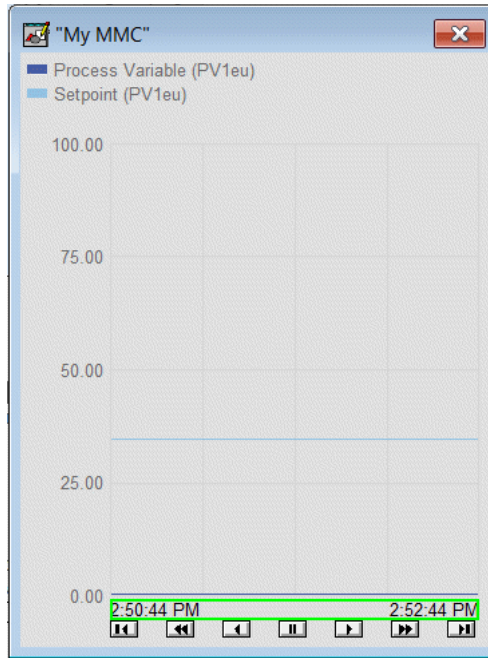


**Table 389 - Trends Tab Description**

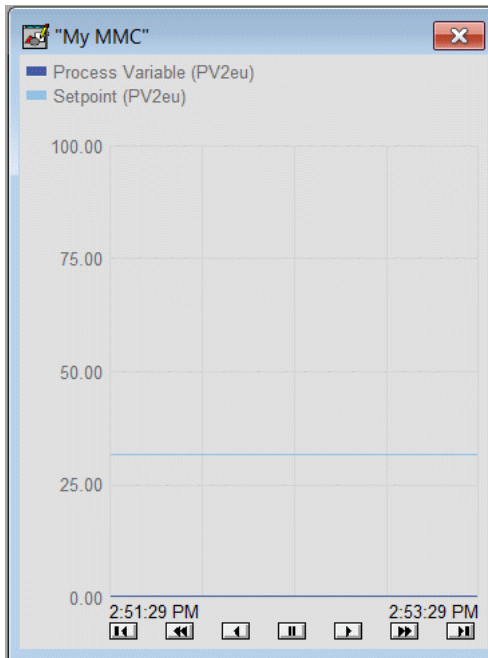
Item	Description
1	Click to open the trends for PV 1 with Setpoint.
2	Click to open the trends for PV 2 with Setpoint.
3	Click to open the trend tab for the control variables.



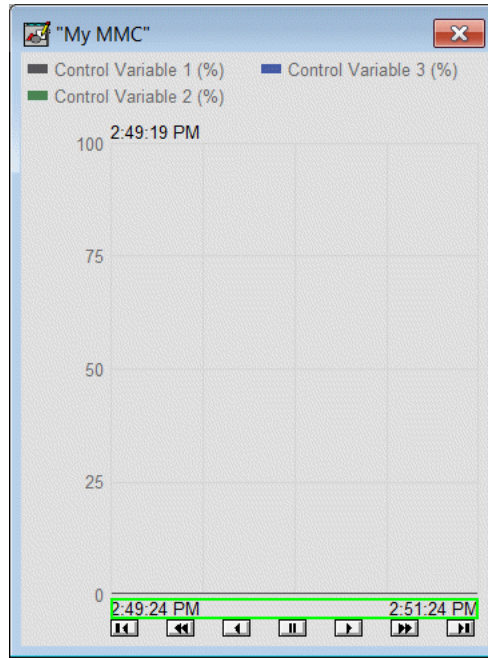
*PV 1 with Setpoint 1 Trends*



*PV 2 with Setpoint 2 Trends*

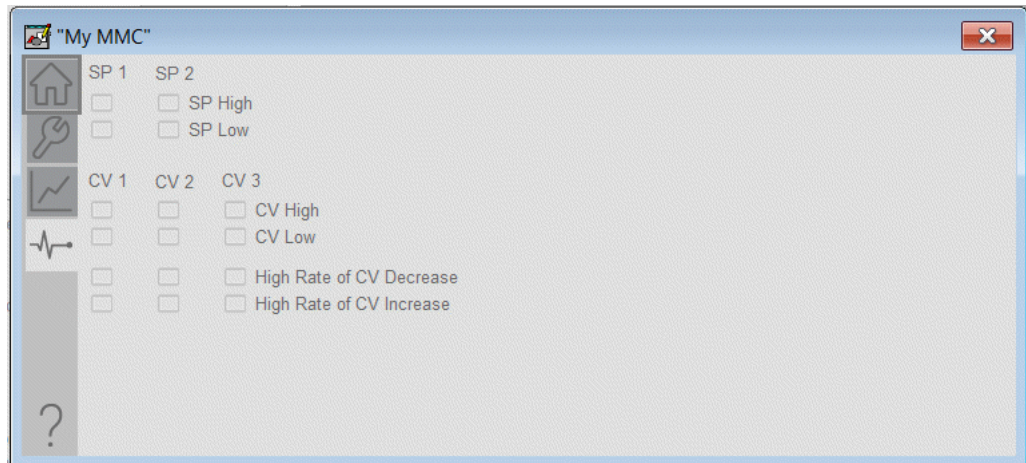


### CV Trends



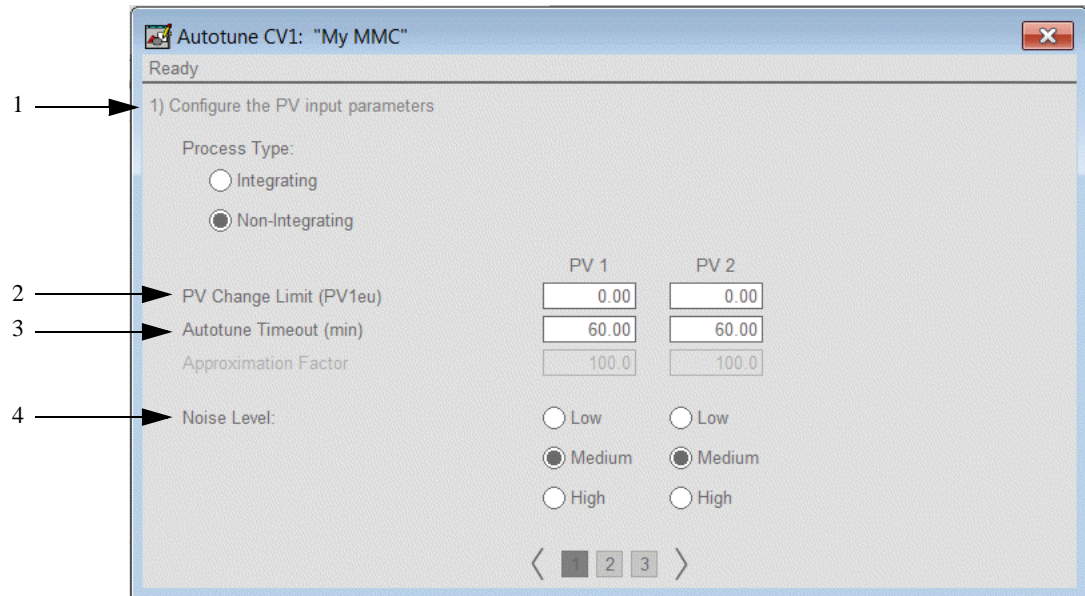
## Diagnostics Tab

The Diagnostic tab provides indications to diagnose device problems. This tab includes device warnings and faults, warning and fault history, and predictive/preventive maintenance data.



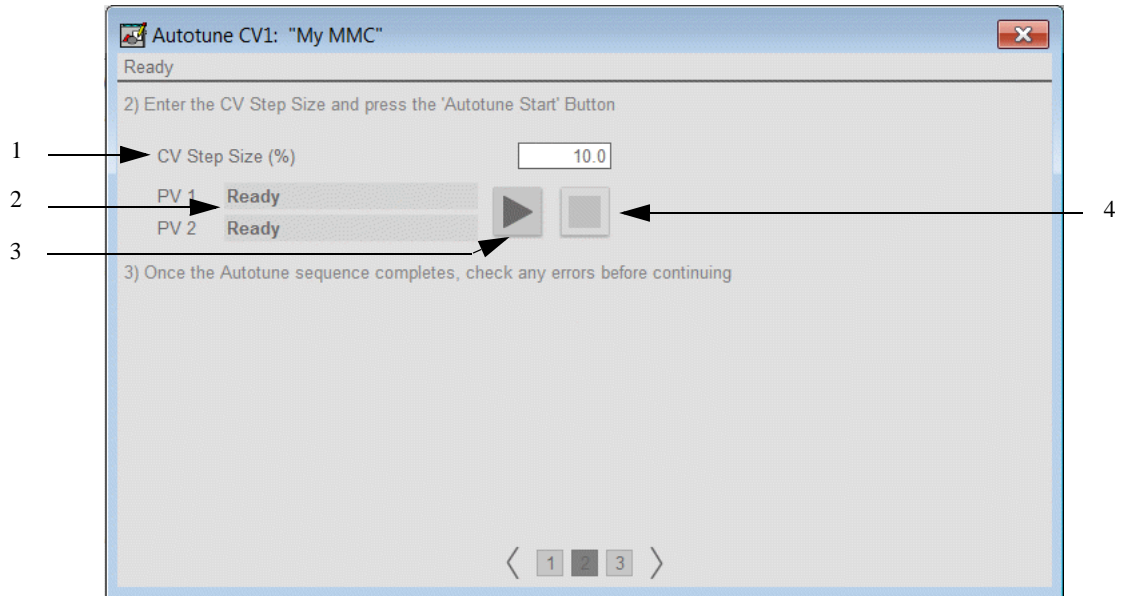
## Modular Multivariable Control (MMC) Autotune

The faceplates in this section let you access all necessary parameters to autotune the MMC function block and hand-tune the instruction.



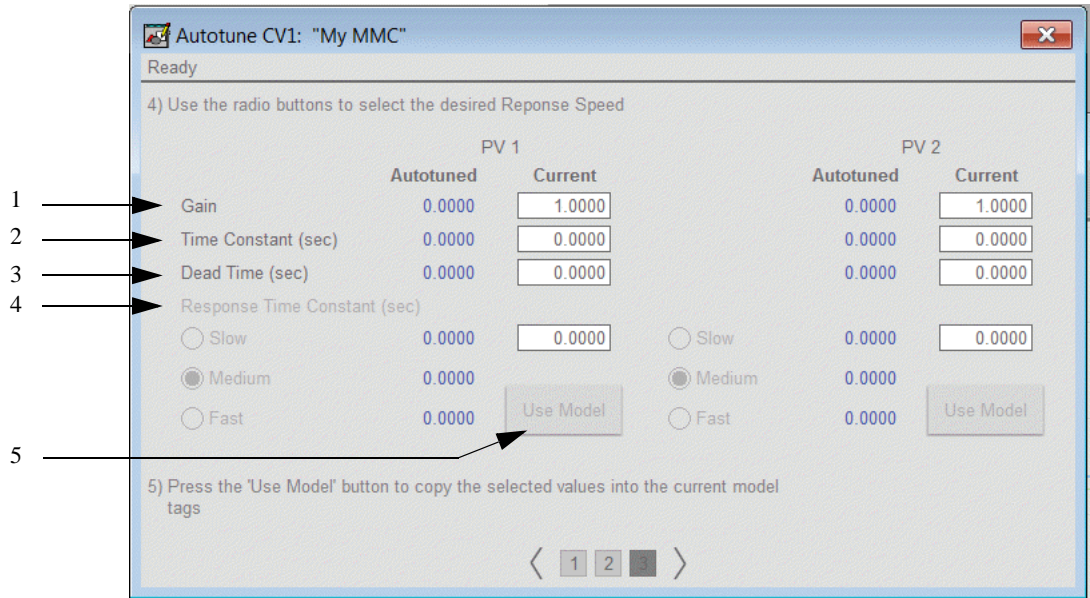
**Table 390 - MMC Autotune Page 1 Description**

Item	Description
1	Click either Integrating or Non-integrating.
2	Type a value for PV1 and PV2 limit scaled in PV units. When Autotune is running and predicted PV exceeds this limit, the tuning is aborted.
3	Type a value for PV1 and PV2 maximum time (in minutes) for autotune to complete following the CV step change. When autotune exceeds this time, tuning is aborted.
4	Click Low, Medium, or High to set the estimate of the noise level expected on PV1 and PV2 to compensate for it during tuning.



**Table 391 - MMC Autotune Page 2 Description**

Item	Description
1	Type a value for CV1 step size in percent for the tuning step test.
2	PV1 and PV2 Autotune status indicator
3	Click to start the autotune process.
4	Click to abort the autotune process. This button also becomes active if the process is aborted due to an error.



**Table 392 - MMC Autotune Page 3 Description**

Item	Description
1	Type a value for the modular multivariable PV1 and PV2 gain. Enter a positive or negative gain depending on process direction.
2	Type a value for the modular multivariable PV1 and PV2 time constant in seconds.
3	Type a value for the modular multivariable PV1 and PV2 deadtime in seconds.
4	Type a value for the PV1 and PV2 tuning parameter that determines the speed of the control variable action in seconds
5	Click to replace the current PV1 and PV2 model parameters with the calculated Autotune PV1 and PV2 model parameters.

## Proportional + Integral + Derivative Enhanced (PIDE)

The Proportional + Integral + Derivative Enhanced (PIDE) instruction provides enhanced capabilities over the standard PID instruction. The instruction uses the velocity form of the PID algorithm. The gain terms are applied to the change in the value of error or PV, not the value of error or PV.

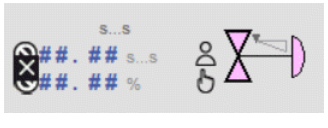
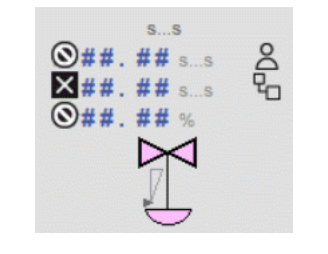
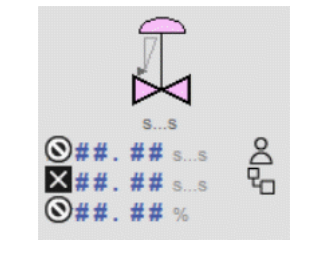

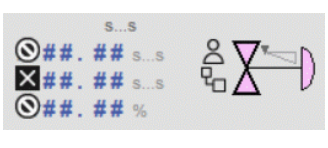
This document is for the visualization files, display elements, global objects, and HMI information. The operation of the Add-On Instructions and controller code is contained in publication [PROCES-RM013](#).

### Display Elements

A display element (global object) is created once and can be referenced multiple times on multiple displays in an application. When changes are made to the original (base) object, the instantiated copies (reference objects) are automatically updated. Use of global objects, with tag structures in the ControlLogix system, aid consistency and save engineering time.

**Table 393 - MMC Display Elements Description**

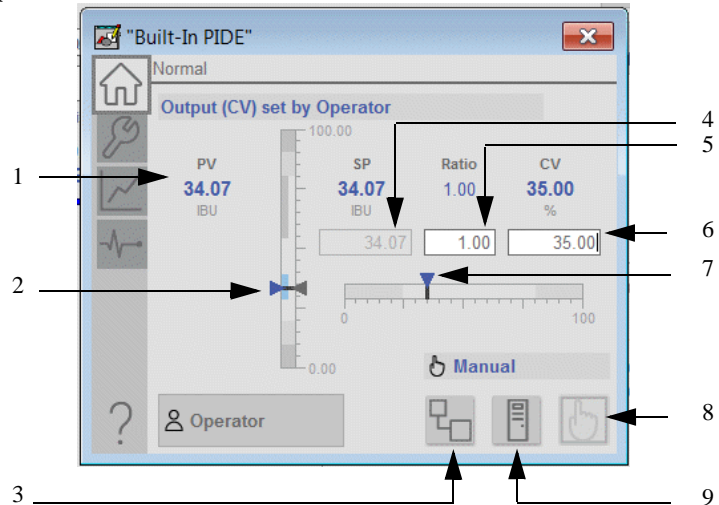
Display Element Name	Display Element	Description
GO_Builtin_PIDE		Proportional + Integral + Derivative Enhanced object with one Process Variables and one Control Variable.
GO_Builtin_PIDE1		Proportional + Integral + Derivative Enhanced object with one Process Variable, one Setpoint, and one Control Variable.
GO_BuiltIn_PIDE_CV		Proportional + Integral + Derivative Enhanced (normal Control Valve for horizontal pipe) object with one Process Variable and one Control Variable.
GO_BuiltIn_PIDE_CV1		Proportional + Integral + Derivative Enhanced (inverted Control Valve for horizontal pipe) object with one Process Variable and one Control Variable.
GO_BuiltIn_PIDE_CV2		Proportional + Integral + Derivative Enhanced (Control Valve for vertical pipe to the left) object with one Process Variable and one Control Variable.

Display Element Name	Display Element	Description
GO_BuiltIn_PIDE_CV3		<p>Proportional + Integral + Derivative Enhanced (Control Valve for vertical pipe to the right) object with one Process Variable and one Control Variable.</p>
GO_BuiltIn_PIDE_CV4		<p>Proportional + Integral + Derivative Enhanced (normal Control Valve for horizontal pipe) object with one Process Variable, one Setpoint, and one Control Variable.</p>
GO_BuiltIn_PIDE_CV5		<p>Proportional + Integral + Derivative Enhanced (inverted Control Valve for horizontal pipe) object with one Process Variable, one Setpoint, and one Control Variable.</p>
GO_BuiltIn_PIDE_CV6		<p>Proportional + Integral + Derivative Enhanced (Control Valve for vertical pipe to the left) object with one Process Variable, one Setpoint, and one Control Variable.</p>
GO_BuiltIn_PIDE_CV7		<p>Proportional + Integral + Derivative Enhanced (Control Valve for vertical pipe to the right) object with one Process Variable, one Setpoint, and one Control Variable.</p>



## Operator Tab

The faceplate initially opens to the Operator ('Home') tab. From here, an operator can monitor the device status and manually operate the device when it is in Operator mode.

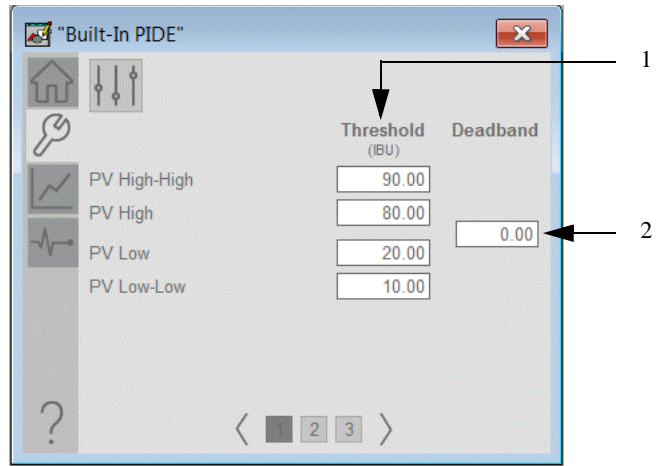


**Table 394 - Operator Tab Description**

Item	Description
1	Current PV value
2	PV Slider
3	Click to request Cascade Loop mode.
4	Type a value for the loop Setpoint.
5	Type a value for the ratio operator multiplier.
6	Type a value for CV.
7	Move this slider to adjust the loop CV output.
8	Click to go to request Manual loop mode.
9	Click to request Auto Loop mode.

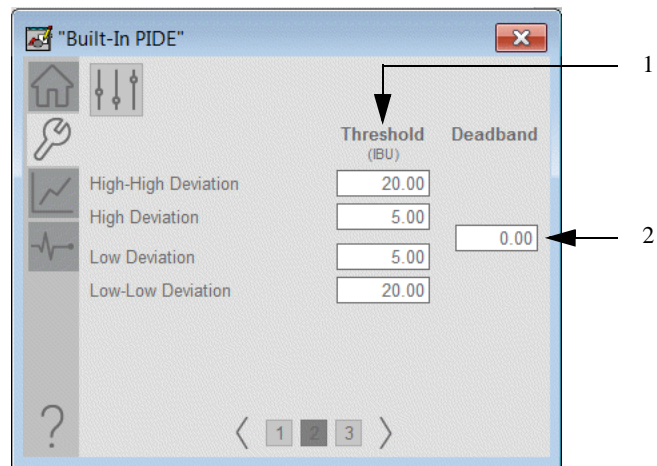
## Maintenance Tab

Maintenance personnel use the information and controls on the Maintenance tab to adjust device parameters, troubleshoot and temporarily work around device problems, and disable the device for routine maintenance.



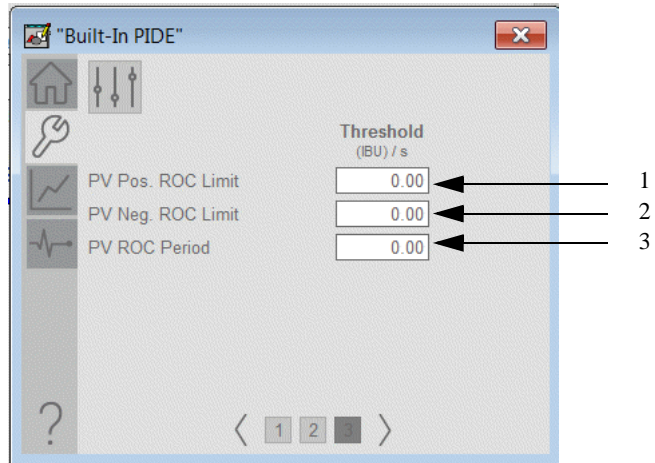
**Table 395 - Maintenance Tab Page 1 Description**

Item	Description
1	Type values for the PV high-high, high, low, and low-low alarm limits.
2	Type a value for the PV alarm limit deadband.



**Table 396 - Maintenance Tab Page 2 Description**

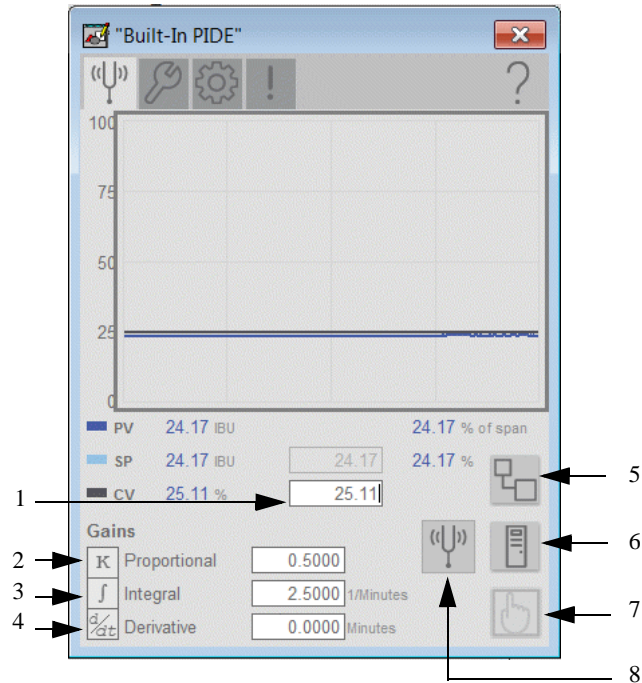
Item	Description
1	Type values for the Deviation high-high, high, low, and low-low alarm limits.
2	Type a value for the Deviation alarm limit deadband.

**Table 397 - Maintenance Tab Page 3 Description**

Item	Description
1	Enter a value for the positive rate of change alarm limit.
2	Enter a value for the negative rate of change alarm limit.
3	Type a value for the PV Rate of change sample period. This value is the time period, in seconds, over which the rate of change for PV is evaluated. Type zero to disable the PV rate of change period checking.

## Advanced Tab

### Tuning Tab



**Table 398 - Tuning Tab Description**

Item	Description
1	Type the value for the control variable.
2	Type the value for the proportional gain.
3	Type the value for the integral gain.
4	Type the value for the derivative gain.
5	Click to request Cascade loop mode.
6	Click to request Auto Loop mode.
7	Click to request Manual Loop mode.
8	Click to show the Autotune (CV1, CV2, or CV3) Operator faceplate.

Maintenance Tab

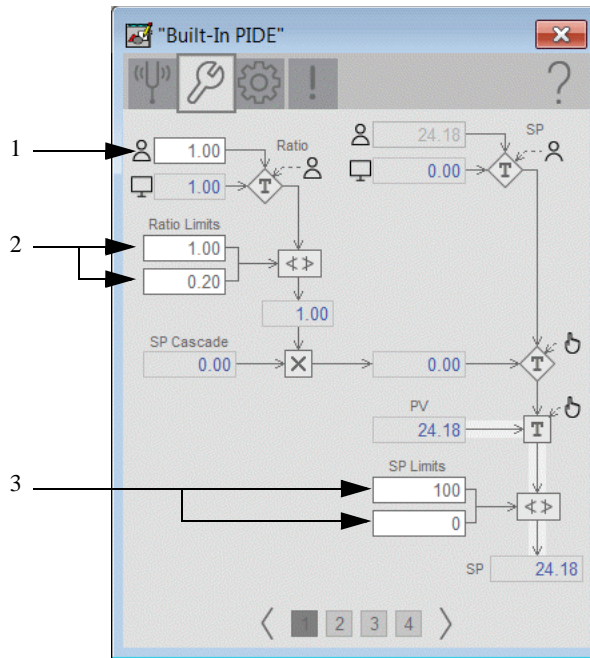
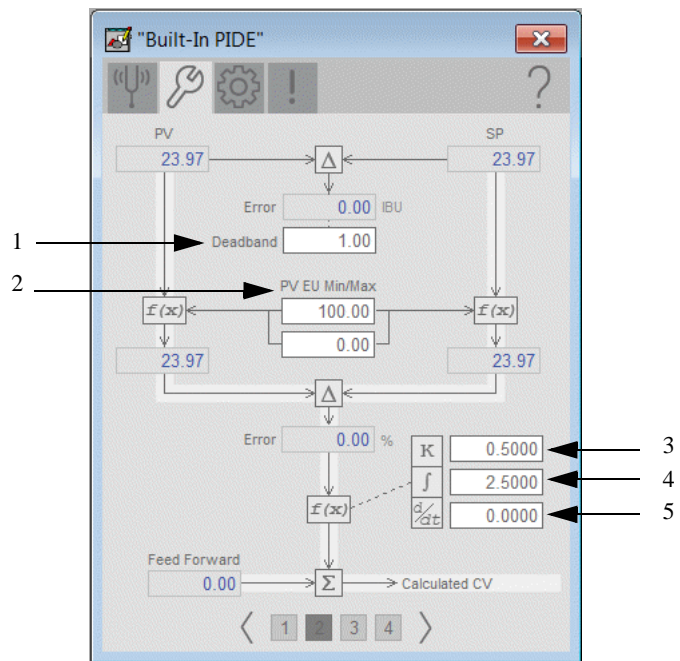


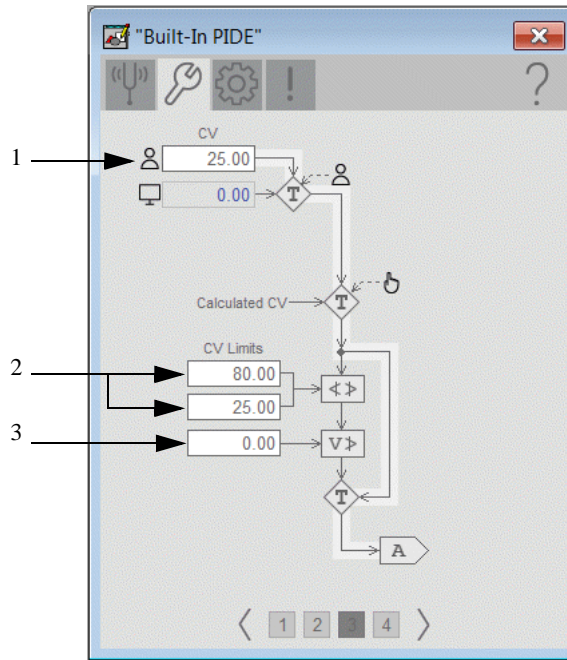
Table 399 - Advanced Maintenance Tab Page 1 Description

Item	Description
1	Type a ratio Operator multiplier.
2	Type values for the high and low ratio limits. These values limit the value of Ratio obtained from Operator or Program Ratio.
3	Type the high and low limits for the setpoint.



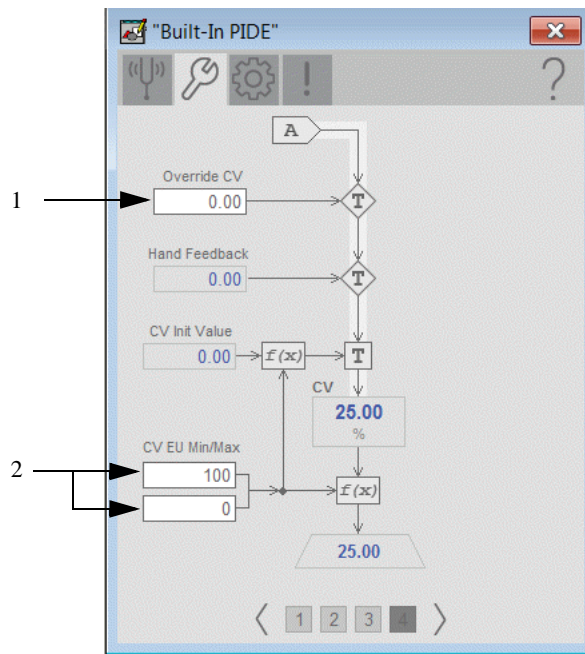
**Table 400 - Advanced Maintenance Tab Page 2 Description**

Item	Description
1	Type a value for the zero-crossing deadband range. Type zero to disable the zero-crossing deadband checking.
2	Type a value for the maximum and minimum scaled values for PV.
3	Type in a value for Proportional gain
4	Type in a value for Integral gain
5	Type in a value for Derivative gain



**Table 401 - Advanced Maintenance Tab Page 3 Description**

Item	Description
1	Type a value for CV when in the Operator Manual mode.
2	Type values for the CV high and low limits.
3	Type a value for CV Rate of Change limit.



**Table 402 - Advanced Maintenance Tab Page 4 Description**

Item	Description
1	Type a value for CV when in the Override mode.
2	Type values for the maximum and minimum values for CV in engineering units.



## Engineering

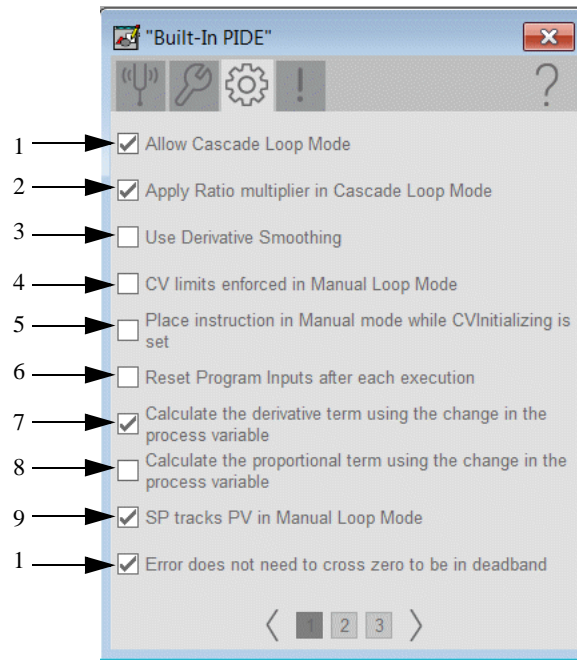
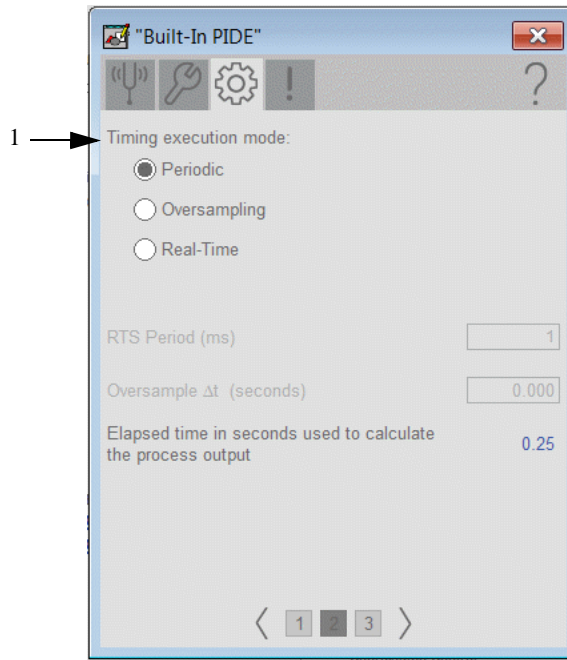


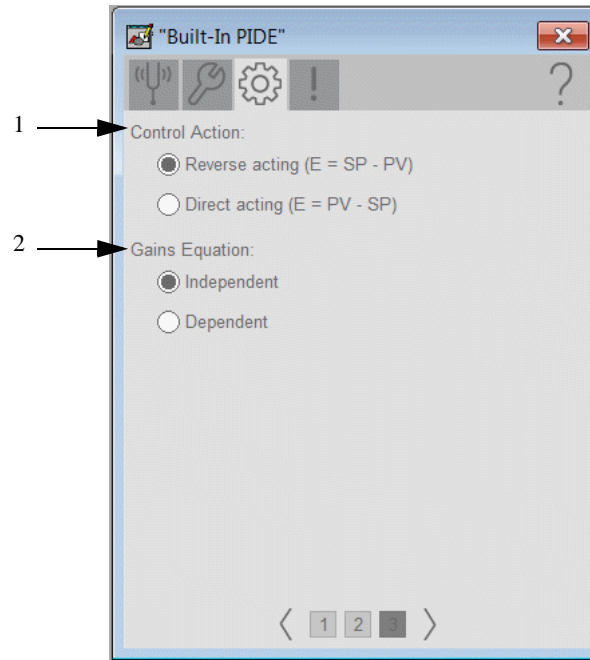
Table 403 - Advanced Engineering Tab Page 1 Description

Item	Description
1	Check to enable Cascade loop mode.
2	Check to enable ratio control when in Cascade mode.
3	Click to smooth changes in the derivative term.
4	Check to limit CV in the Manual mode.
5	Check to set the Loop mode to manual when CV initialization is requested. Clear the checkbox to leave the Loop mode unchanged when initialization is requested. When the initialization request clears, the loop resumes control in its previous Loop mode.
6	Click to clear all program request inputs after each execution of the instruction.
7	Click to calculate the derivative term by using the change in the process variable (PVPercent). Clear this checkbox to use the change in error (EPercent).
8	Click to calculate the proportional term by using the change in process variable (PVPercent). Clear this checkbox to use the change in error (EPercent).
9	Click to have SP track PV when in Manual mode. This setting is ignored when in Cascade or Auto mode.
10	Click to disable zero-crossing for the deadband calculation.



**Table 404 - Advanced Engineering Tab Page 2 Description**

Item	Description
1	Click to select the timing execution mode.

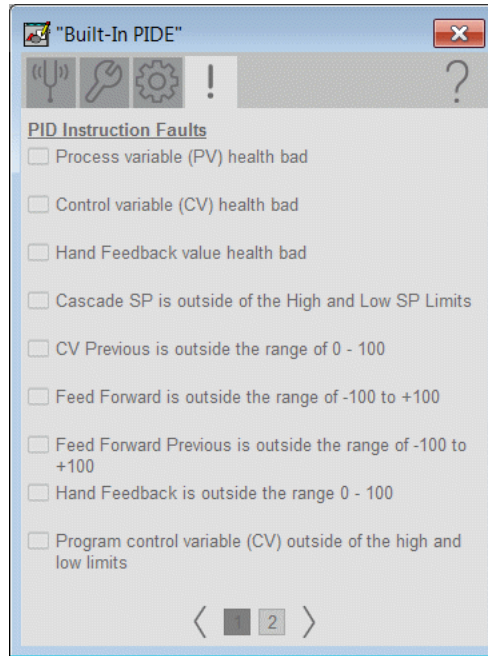


**Table 405 - Advanced Engineering Tab Page 3 Description**

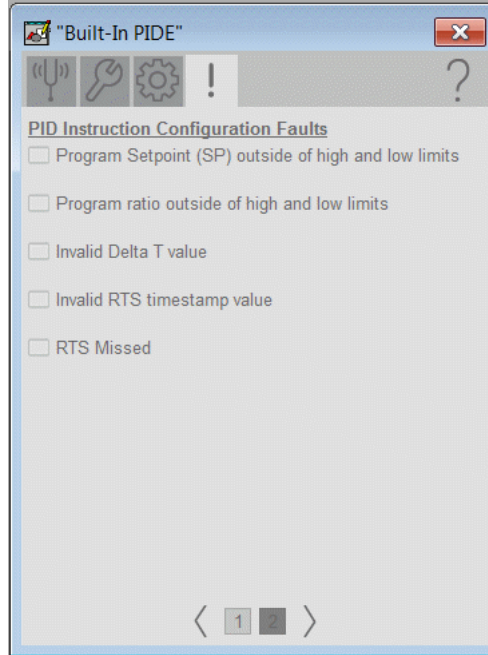
Item	Description
1	Click to select the method of calculating error.
2	Click to select Independent or Dependant for the gains equation.

### Faults Tab

Page 1 of the Diagnostics tab displays PID Instruction faults.

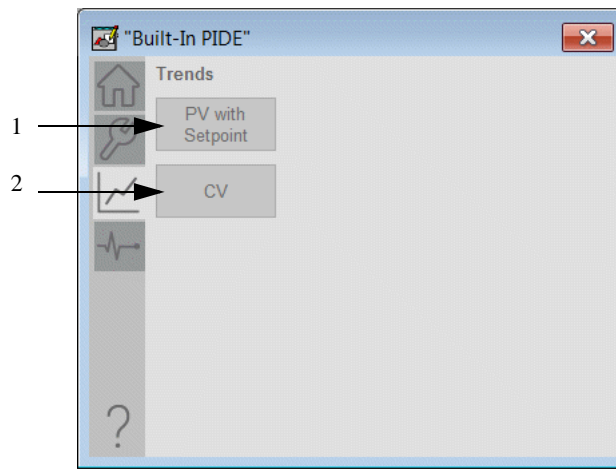


Page 2 of the Diagnostics tab displays PID Instruction configuration faults.



## Trends Tab

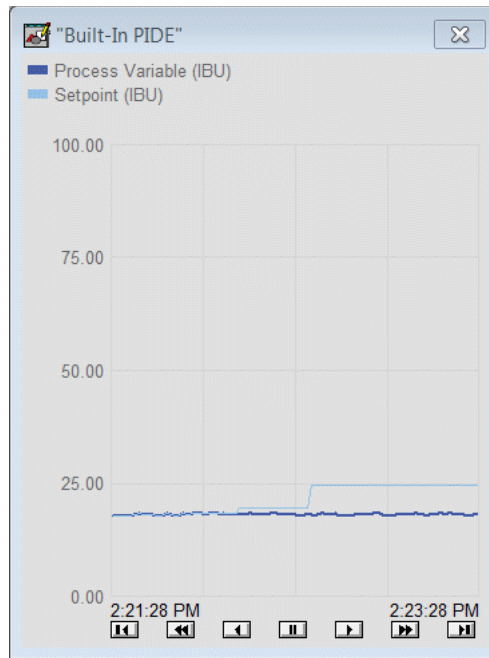
The Trends tab shows trend charts of key device data over time. These faceplate trends provide a quick view of current device performance to supplement, but not replace, dedicated historical or live trend displays. For basic trends tab functionality, See [Trends Display on page 37](#).



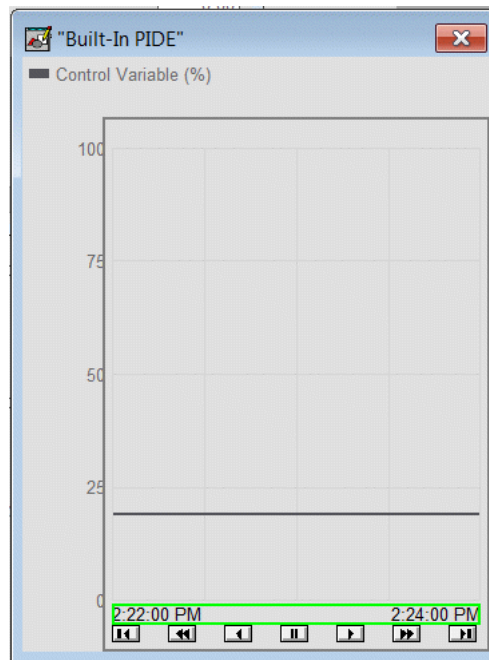
**Table 406 - Trends Tab Description**

Item	Description
1	Click to open the trends for the PV with Setpoint.
2	Click to open the trends tab for the control variables.

*PV with Setpoint Trends Tab*

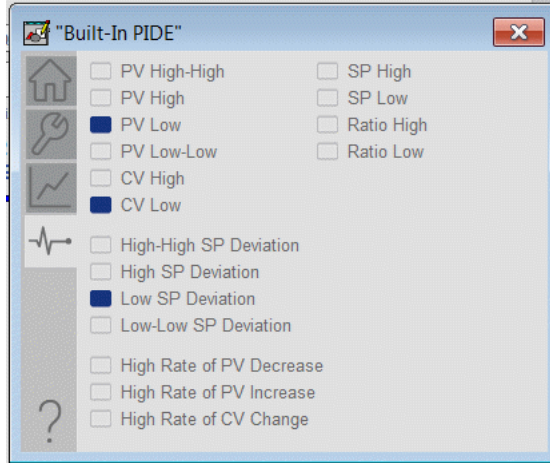


*CV Trends Tab*



## Diagnostics Tab

The Diagnostic tab provides indications to diagnose device problems. This tab includes device warnings and faults, warning and fault history, and predictive/preventive maintenance data.



## Ramp/Soak (RMPS)

The Ramp/Soak (RMPS) instruction provides for a number of segments of alternating ramp and soak periods.

This document is for the visualization files, display elements, global objects, and HMI information. The operation of the Add-On Instructions and controller code is contained in publication [PROCES-RM013](#).

## Display Elements

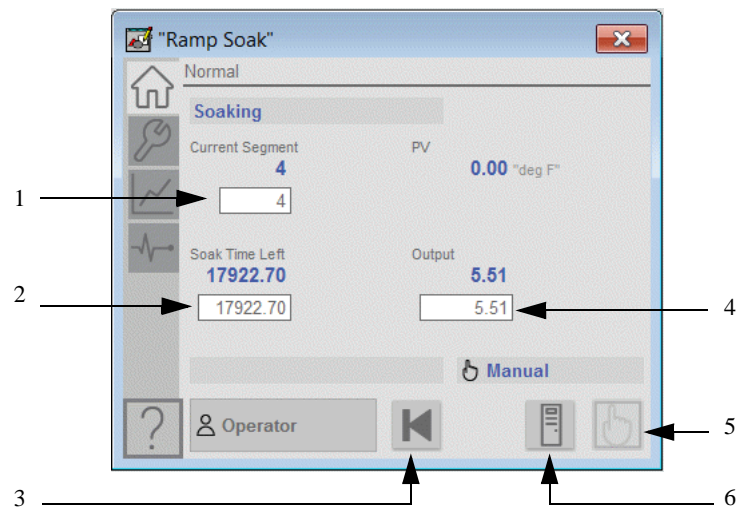
A display element (global object) is created once and can be referenced multiple times on multiple displays in an application. When changes are made to the original (base) object, the instantiated copies (reference objects) are automatically updated. Use of global objects, with tag structures in the ControlLogix system, aid consistency and save engineering time.

**Table 407 - RMPS Display Elements Description**

Display Element Name	Display Element	Description
GO_BuiltIn_RMPS		Ramp Soak global object.

## Operator Tab

The Faceplate initially opens to the Operator (Home) tab. From here, an operator can monitor the device status and manually operate the device when it is in Operator mode. Several features are common to all Add-On Instructions faceplates. See [Basic Faceplate Attributes on page 32](#).



**Table 408 - Operator Tab Description**

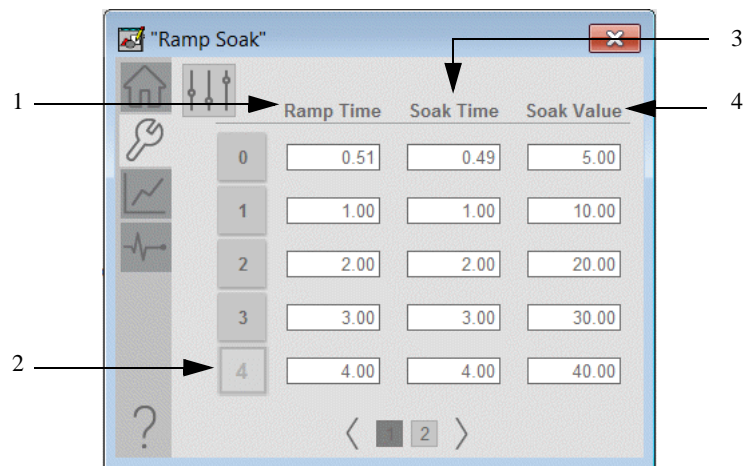
Item	Description
1	Type a value for the Operator Segment. This value is used if Ramp/Soak is in the Manual mode.
2	Type a value for the Operator Soak Time Left. This value is used if Ramp/Soak is in the Manual mode.
3	Click to initialize Current Segment and Soak Time Left.
4	Type a value for the Operator output value. This value is used as the Output when Ramp/Soak is in the Manual mode.
5	Click to request Manual Loop mode.
6	Click to request Auto Loop mode.



## Maintenance Tab

Maintenance personnel use the information and controls on the Maintenance tab to adjust device parameters, troubleshoot, temporarily work around device problems, and disable the device for routine maintenance. Several features are common to all Add-On Instructions faceplates. See [Basic Faceplate Attributes on page 32](#)

The Maintenance tab has inputs for Ramp Time, Soak Time, and Soak Value for each segment. The segments are split between two pages.

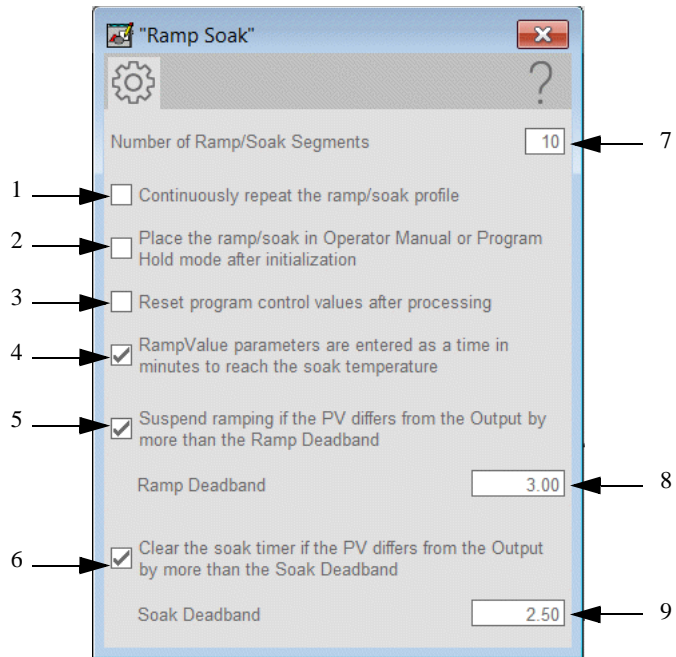


**Table 409 - Maintenance Tab Description**

Item	Description
1	Type a value for Ramp time, in minutes or units/minute, for the desired segments.
2	Click to select the current segment.
3	Type a value for Soak Time, in minutes, for the desired segments.
4	Type a value for Soak Value for the desired segments.

## Advanced Tab

### Engineering

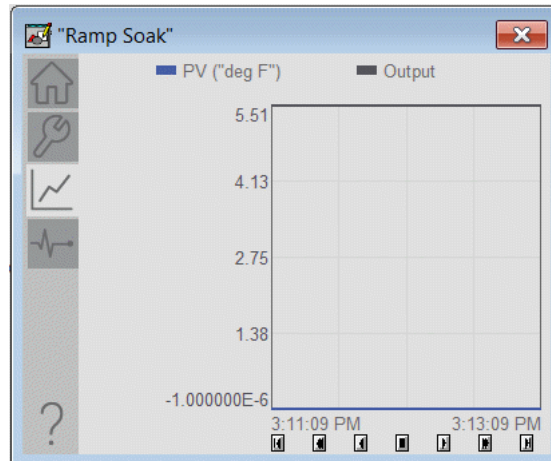


**Table 410 - Engineering Tab Description**

Item	Description
1	Check to set for cyclic action. Clear this checkbox to set for single action. Cyclic action continuously repeats the ramp/soak profile. Single action performs the ramp/ soak profile once and then stops.
2	Click to set ramp/Soak in Manual or Program Hold mode after initialization. Clear this checkbox to have Ramp/Soak remain in its previous mode after initialization completes.
3	Click to reset program control values.
4	Click so that the RampValue parameter entered is in minutes. Clear this checkbox if the RampValue parameter is entered in units/minute.
5	Click to set Guaranteed Ramp. If set and the instruction is in Auto, ramping is temporarily suspended if the PV differs from the Output by more than RampDeadband.
6	Click to clear the soak timer.
7	Type the number of ramp soak segments.
8	Type a value (Guaranteed Ramp Deadband) in engineering units that PV is allowed to differ from the output when GuarRamp is on.
9	Type a value in engineering units that the PV is allowed to differ from the output when GuarSoak is on.

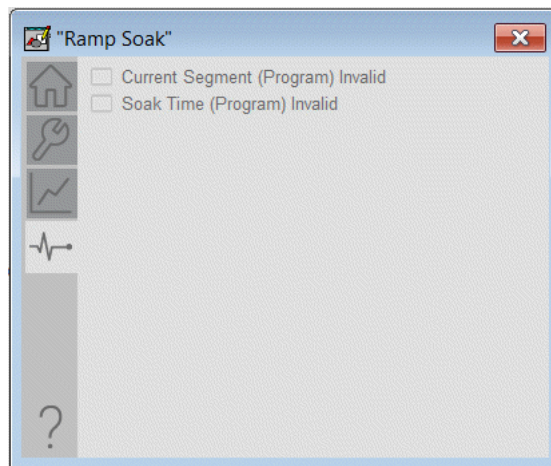
## Trends Tab

The Trends tab shows trend charts of key device data over time. These faceplate trends provide a quick view of current device performance to supplement, but not replace, dedicated historical or live trend displays. For basic trends tab functionality, See [Trends Display on page 37](#).



## Diagnostics Tab

The Diagnostic tab provides indications to diagnose device problems. This tab includes device warnings and faults, warning and fault history, and predictive/preventive maintenance data.



# Totalizer (TOT)

The TOT instruction provides a time-scaled accumulation of an analog input value.

This document is for the visualization files, display elements, global objects, and HMI information. The operation of the Add-On Instructions and controller code is contained in publication [PROCES-RM013](#).

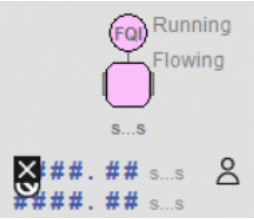
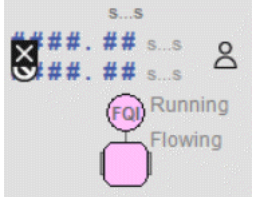
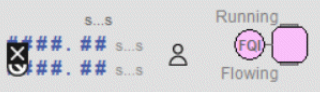
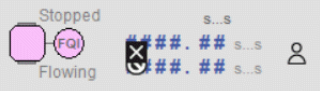
## Display Elements

A display element (global object) is created once and can be referenced multiple times on multiple displays in an application. When changes are made to the original (base) object, the instantiated copies (reference objects) are automatically updated. Use of global objects, with tag structures in the ControlLogix system, aid consistency and save engineering time.

**Table 411 - TOT Display Element Description**

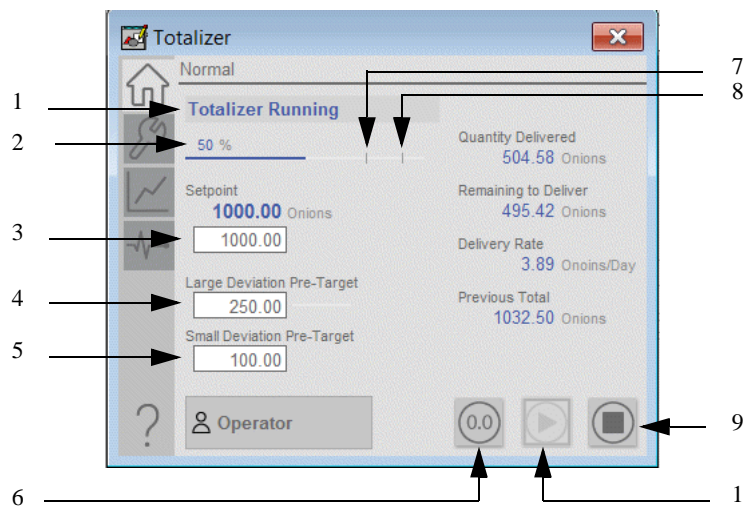
Display Element Name	Display Element	Description
GO_BuiltIn_Totalize rTgt		Totalizer with target, horizontal orientation - top
GO_BuiltIn_Totalize rTgt1		Totalizer with target, horizontal orientation - bottom
GO_BuiltIn_Totalize rTgt2		Totalizer with target, vertical orientation - right
GO_BuiltIn_Totalize rTgt3		Totalizer with target, vertical orientation - left

**Table 411 - TOT Display Element Description**

Display Element Name	Display Element	Description
GO_BuiltIn_Totalizer		Totalizer, horizontal orientation - top
GO_BuiltIn_Totalizer1		Totalizer, horizontal orientation - bottom
GO_BuiltIn_Totalizer2		Totalizer, vertical orientation - right
GO_BuiltIn_Totalizer3		Totalizer, vertical orientation - left

## Operator Tab

The Faceplate initially opens to the Operator (Home) tab. From here, an operator can monitor the device status and manually operate the device when it is in Operator mode. Several features are common to all Add-On Instructions faceplates. See [Basic Faceplate Attributes on page 32](#).

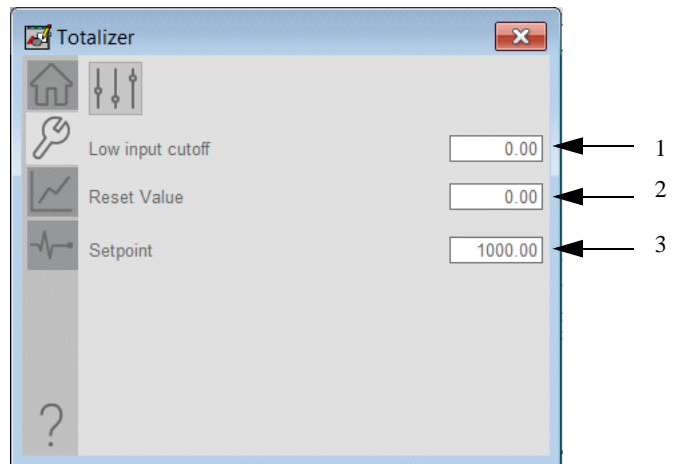


**Table 412 - Operator Tab Description**

Item	Description
1	Totalizer status
2	Flow indicator
3	Type the setpoint value for the totalizer input.
4	Type a value for the large deviation pre-target value of Total compared to Target. This value is expressed as a deviation from the Target.
5	Type a value for the small deviation pre-target value of Total compared to Target. This value is expressed as a deviation from the Target.
6	Click to reset Totalizer.
7	Large Deviation Pre-Target
8	Small Deviation Pre-Target
9	Click to stop Totalizer.
10	Click to start Totalizer.

## Maintenance Tab

Maintenance personnel use the information and controls on the Maintenance tab to adjust device parameters, troubleshoot, temporarily work around device problems, and disable the device for routine maintenance. Several features are common to all Add-On Instructions faceplates. See [Basic Faceplate Attributes on page 32](#)

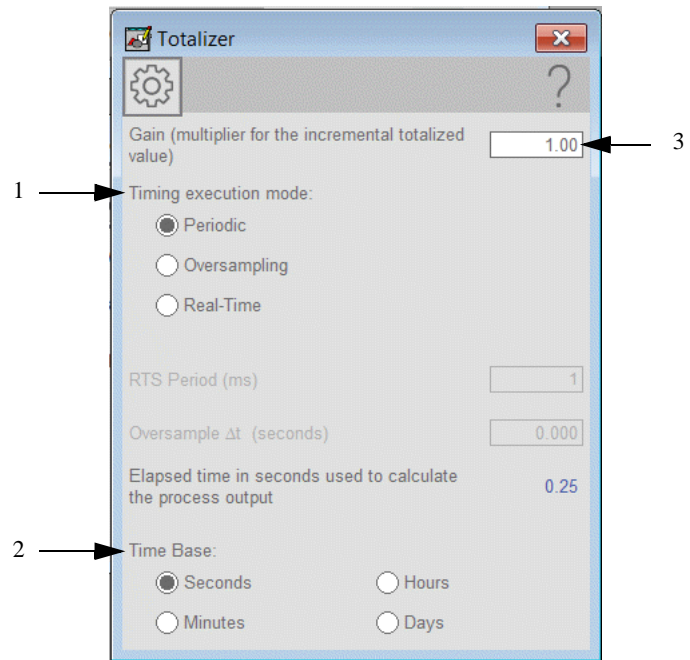


**Table 413 - Maintenance Tab Description**

Item	Description
1	Type a value for the low input cutoff. When the input is set at or below LowInCutoff, totalization stops.
2	Type a value for reset input.
3	Type a value for the setpoint.

## Advanced Tab

### Engineering



**Table 414 - Engineering Tab Description**

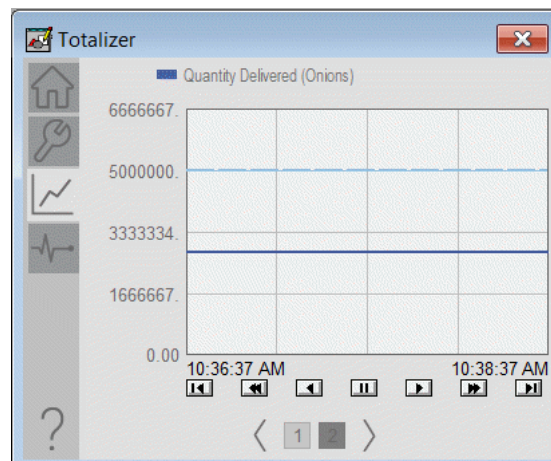
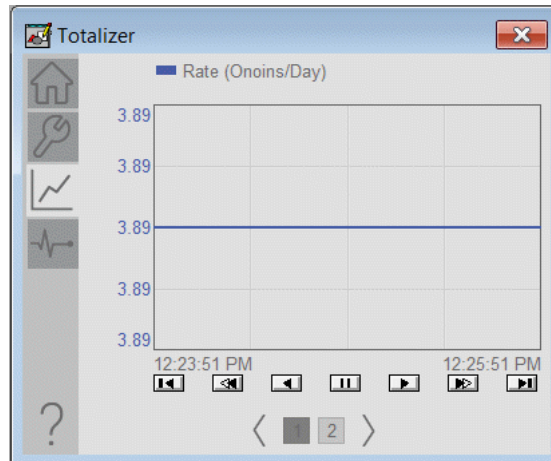
Item	Description
1	Click to select the timing execution mode.
2	Click to select the time base for the time base input.
3	Type a value for the multiplier of the incremental totalized value.



## Trends Tab

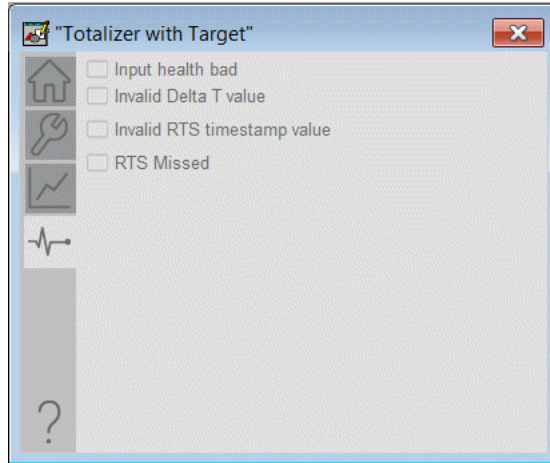
The Trends tab shows trend charts of key device data over time. These faceplate trends provide a quick view of current device performance to supplement, but not replace, dedicated historical or live trend displays. For basic trends tab functionality, See [Trends Display on page 37](#).

The trend tab is split into two pages.



## Diagnostics Tab

The Diagnostic tab provides indications to diagnose device problems. This tab includes device warnings and faults, warning and fault history, and predictive/preventive maintenance data.





## Rockwell Automation Support

Use the following resources to access support information.

<b>Technical Support Center</b>	Knowledgebase Articles, How-to Videos, FAQs, Chat, User Forums, and Product Notification Updates.	<a href="https://rockwellautomation.custhelp.com/">https://rockwellautomation.custhelp.com/</a>
<b>Local Technical Support Phone Numbers</b>	Locate the phone number for your country.	<a href="http://www.rockwellautomation.com/global/support/get-support-now.page">http://www.rockwellautomation.com/global/support/get-support-now.page</a>
<b>Direct Dial Codes</b>	Find the Direct Dial Code for your product. Use the code to route your call directly to a technical support engineer.	<a href="http://www.rockwellautomation.com/global/support/direct-dial.page">http://www.rockwellautomation.com/global/support/direct-dial.page</a>
<b>Literature Library</b>	Installation Instructions, Manuals, Brochures, and Technical Data.	<a href="http://www.rockwellautomation.com/global/literature-library/overview.page">http://www.rockwellautomation.com/global/literature-library/overview.page</a>
<b>Product Compatibility and Download Center (PCDC)</b>	Get help determining how products interact, check features and capabilities, and find associated firmware.	<a href="http://www.rockwellautomation.com/global/support/pcdc.page">http://www.rockwellautomation.com/global/support/pcdc.page</a>

## Documentation Feedback

Rockwell Automation maintains current product environmental information on its website at <http://www.rockwellautomation.com/rockwellautomation/about-us/sustainability->

Allen-Bradley, ControlLogix, DeviceLogix, E1 Plus, E300, FactoryTalk, PanelView, PlantPAx, PowerFlex, Rockwell Software, Rockwell Automation, SMC, and Studio 5000 Logix Designer are trademarks of Rockwell Automation, Inc.

Rockwell Otomasyon Ticaret A.Ş., Kar Plaza İş Merkezi E Blok Kat:6 34752 İçerenköy, İstanbul, Tel: +90 (216) 5698400

**[www.rockwellautomation.com](http://www.rockwellautomation.com)**

### Power, Control and Information Solutions Headquarters

Americas: Rockwell Automation, 1201 South Second Street, Milwaukee, WI 53204-2496 USA, Tel: (1) 414.382.2000, Fax: (1) 414.382.4444

Europe/Middle East/Africa: Rockwell Automation NV, Pegasus Park, De Kleetlaan 12a, 1831 Diegem, Belgium, Tel: (32) 2 663 0600, Fax: (32) 2 663 0640

Asia Pacific: Rockwell Automation, Level 14, Core F, Cyberport 3, 100 Cyberport Road, Hong Kong, Tel: (852) 2887 4788, Fax: (852) 2508 1846

Publication PROCES-RM014F-EN-P - April 2023

Supersedes Publication PROCES-RM014E-EN-P - December 2021

Copyright © 2023 Rockwell Automation, Inc. All rights reserved. Printed in the U.S.A.