

4.5L OEM Diesel Engines (PSS/PSL/PVL/PVS/PWX- /PSX/PWL/PWS)



OPERATOR'S MANUAL

4.5 L OEM Diesel Engines (PSS/PSL- /PVL/PVS/PWX/PSX/PWL/PWS)

OMRG39498 ISSUE 31AUG22 (ENGLISH)

CALIFORNIA

Proposition 65 Warning

Diesel engine exhaust and some of its constituents are known to the State of California to cause cancer, birth defects, and other reproductive harm.

If this product contains a gasoline engine:

⚠ WARNING

The engine exhaust from this product contains chemicals known to the State of California to cause cancer, birth defects or other reproductive harm.

The State of California requires the above two warnings.

John Deere Power Systems

Worldwide Edition
PRINTED IN U.S.A.

TP-6985 8/22



Introduction

OEM Engine and Drivetrain Warranty Registration

RG24614 —UN—21OCT13



Scan this code to register your OEM engine or drivetrain product online. You can also visit us directly at <http://jdpswarrantyreg.deere.com/WarrantyReg>.

Why registering your OEM engine or drivetrain product is a really smart idea:

- **Get faster service.** Registering your engine or drivetrain product gives us the information we need to meet your service needs promptly and completely.
- **Protect your investment.** You'll be kept up-to-date on engine or drivetrain product updates.
- **Extend your warranty.** You'll be given the option to extend your coverage before your standard warranty term expires.
- **Stay informed.** Be the first to know about new products and money-saving offers from John Deere.

You're Covered

When you buy a John Deere engine or drivetrain product you aren't just buying pistons and crankshafts and gear drives. You're buying the ability to get work done. Without downtime, without worries, and without hassles. And you're buying the assurance that if you do need help, a strong support network will be there — ready to step in.

Confidence. That's what John Deere engines, John Deere drivetrains, and John Deere Warranties are all about.

Long durations. Warranties designed to give you confidence in your engine or drivetrain product.

Worldwide support. Get service when and where you need it. John Deere has 4,000+ service locations worldwide.

Genuine John Deere parts and service. Authorized service outlets will use only new or remanufactured parts or components furnished by John Deere.

Warranty Duration

Equipment operators can't afford downtime or unexpected repairs. That's why we offer comprehensive warranties on our OEM industrial engines, marine engines, and drivetrain products.

- **OEM Engines:** 2-year/2,000-hour warranty, with unlimited hours in the first year.
- **Drivetrain Products:** 12-month/2000-hour warranty. In the absence of a functional hour meter, hours of use will be determined on the basis of 12 hours of use per calendar day.

These warranties take effect the date the engine or drivetrain product is delivered to the first retail purchaser. Be sure to register your engine or drivetrain product and take full advantage of the John Deere service and support network.

In addition, engine extended warranties are available under certain conditions. John Deere offers a variety of purchased warranties to extend the warranty period for your engine. You'll be given the option to extend your coverage before your standard warranty term expires.

Obtaining Warranty Service

Warranty service must be requested through an authorized John Deere service outlet before the expiration of the warranty. Evidence of the engine's or drivetrain product's delivery date to the first retail purchaser must be presented when requesting warranty service. Authorized service outlets include:

- John Deere distributor
- John Deere OEM service dealer
- John Deere equipment dealer
- John Deere marine dealer

Worldwide Support Network

Visit <https://dealerlocator.deere.com/> or <https://dealerlocator.deere.ca/> to find the authorized engine or drivetrain service location nearest you. For complete warranty details visit <https://www.deere.com/en/parts-and-service/warranty-and-protection-plans/warranties/warranty-statements> or <https://www.deere.ca/en/parts-and-service/warranty-and-protection-plans/warranties/warranty-statements> to view, download, or print the warranty statement for your engine or drivetrain product.

GM52594,0000996 -19-26MAY22-1/1

Foreword

READ THIS MANUAL carefully to learn how to operate and service the engine correctly. Failure to do so could result in personal injury or equipment damage.

THIS MANUAL SHOULD BE CONSIDERED a permanent part of the engine and should remain with the engine when it is sold.

MEASUREMENTS IN THIS MANUAL are given in both metric and customary U.S. unit equivalents. Use only correct replacement parts and fasteners. Metric and inch fasteners may require a specific metric or inch wrench.

RIGHT-HAND AND LEFT-HAND sides are determined by standing at the drive or flywheel end (rear) of the engine and facing toward the front of the engine.

WRITE ENGINE SERIAL NUMBERS and option codes in the spaces indicated in the Record Keeping Section. Accurately record all the numbers. The dealer also

needs these numbers when parts are ordered. File the identification numbers in a secure place off the engine.

SETTING FUEL DELIVERY beyond published factory specifications or otherwise overpowering will result in loss of warranty protection for the engine.

CERTAIN ENGINE ACCESSORIES such as radiator, air cleaner, and instruments are optional equipment on John Deere OEM Engines. These accessories may be provided by the equipment manufacturer instead of John Deere. This operator's manual applies only to the engine and those options available through the John Deere distribution network.

NOTE: This operator's manual covers only engines provided to OEM (Original Equipment Manufacturers). For engines in Deere machines, refer to the machine operators manual.

OURGP12,0000BD -19-11AUG21-1/1

Emissions Performance and Tampering

Operation and Maintenance

The engine, including the emissions control system, shall be operated, used, and maintained in accordance with the instructions provided in this manual to maintain the emissions performance of the engine within the requirements applicable to the engine's category/certification.

Tampering

No deliberate tampering with or misuse of the engine emissions control system shall take place; in particular with regard to deactivating or not maintaining an exhaust gas recirculation (EGR) or a DEF dosing system. Tampering with an engine's emissions control system will void the European Union (EU) type approval and applicable emissions-related warranties.

DX,EMISSIONS,PERFORM -19-12JAN18-1/1

Engine Owner

John Deere Engine Owner:

It is important for the new engine to be registered for factory warranty. Registering the engine will allow the Service Dealer to verify the warranty status should a repair be needed. The easiest way to register the engine is via the internet. To register the engine for warranty via the internet, please use the following URL: <http://www.johndeere.com/enginewarranty>

The John Deere Engine Distributor or local John Deere Service Dealer can also provide this service. Engine service can be done by all AG, C&F, and JDPS branded dealers. To view the John Deere Service Dealer network or locate the nearest Dealer, use the following URL: <http://www.johndeere.com/dealer>

JR74534,000026F -19-19AUG21-1/1

Download Instructions

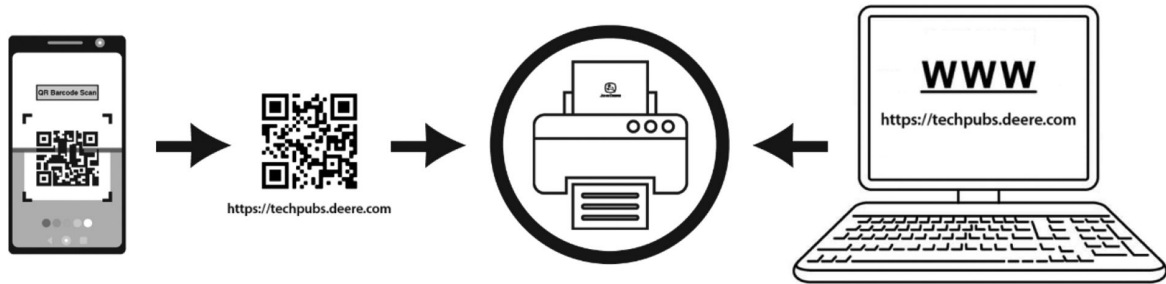

Instructions, manuals, and other documents may be downloaded at [www.techpubs.deere.com](https://techpubs.deere.com). Scanning the QR code on a mobile device will route to the site automatically.

Les instructions, les manuels et autres documents peuvent être téléchargés à cette adresse: [www.techpubs.deere.com](https://techpubs.deere.com). Scanner le QR code via un appareil mobile mène automatiquement au site.

Istruzioni, manuali e altri documenti possono essere scaricati su [www.techpubs.deere.com](https://techpubs.deere.com). La scansione del codice QR su un dispositivo portatile indirizza automaticamente al sito.

Anleitungen, Handbücher und andere Dokumente können unter [www.techpubs.deere.com](https://techpubs.deere.com) heruntergeladen werden. Durch Scannen des QR-Codes mit einem Mobilgerät wird man automatisch zur Webseite weitergeleitet.

Las instrucciones, los manuales y otros documentos se pueden descargar en [www.techpubs.deere.com](https://techpubs.deere.com). Al escanear el código QR en un dispositivo móvil, se abrirá automáticamente el sitio web.

Instruções, manuais e outros documentos podem ser baixados em [www.techpubs.deere.com](https://techpubs.deere.com). A leitura do código QR em um dispositivo móvel levará você automaticamente para o site.

Инструкции, руководства и другие документы можно загрузить на странице [www.techpubs.deere.com](https://techpubs.deere.com). Сканирование QR-кода на мобильном устройстве будет автоматически отправлять на сайт.

Identification Views

*NOTE: There are multiple engine configurations.
Base engine model shown.*

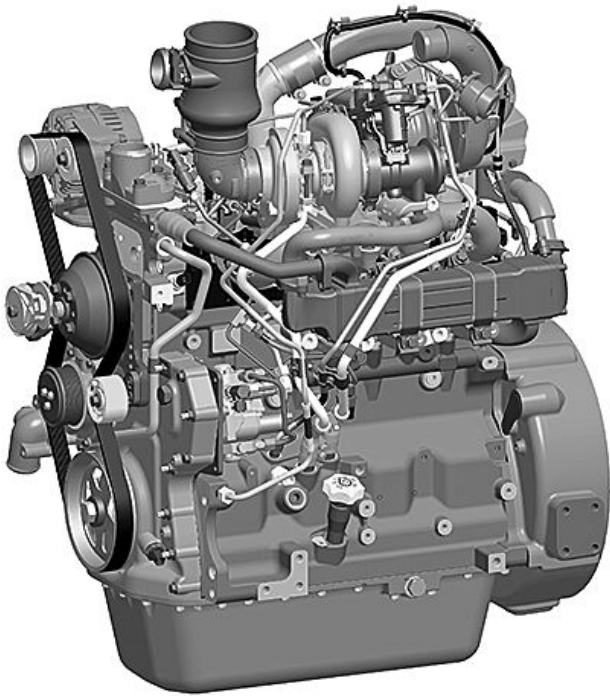

John Deere 4045 Base Engine

RG25233—UN—10MAR14

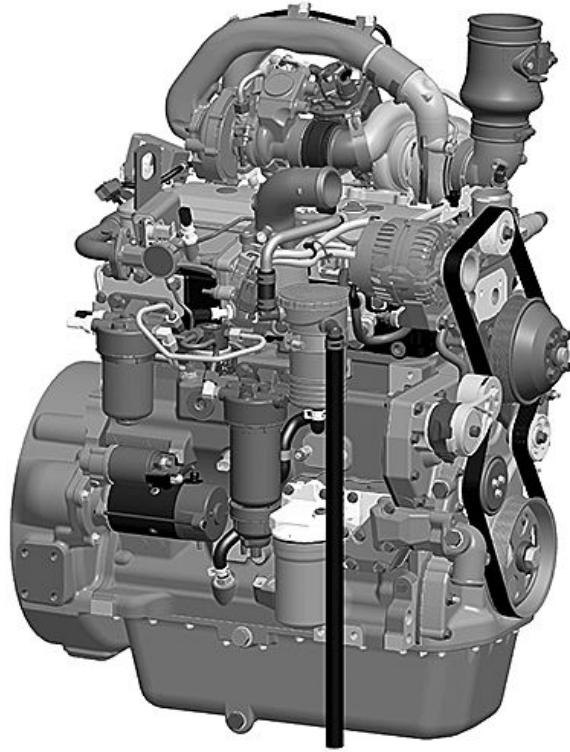

John Deere 4045 Base Engine

RG25234—UN—10MAR14

Continued on next page

ZE59858,0000007 -19-05FEB21-1/2

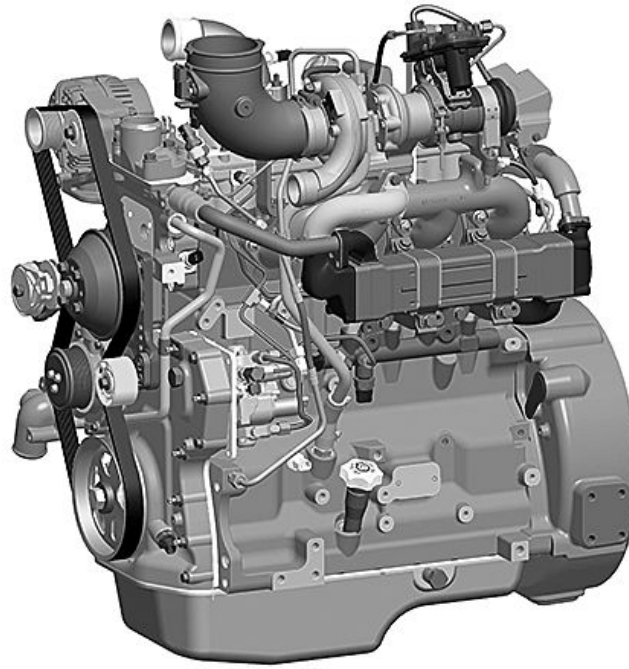

John Deere 4045 Base Engine

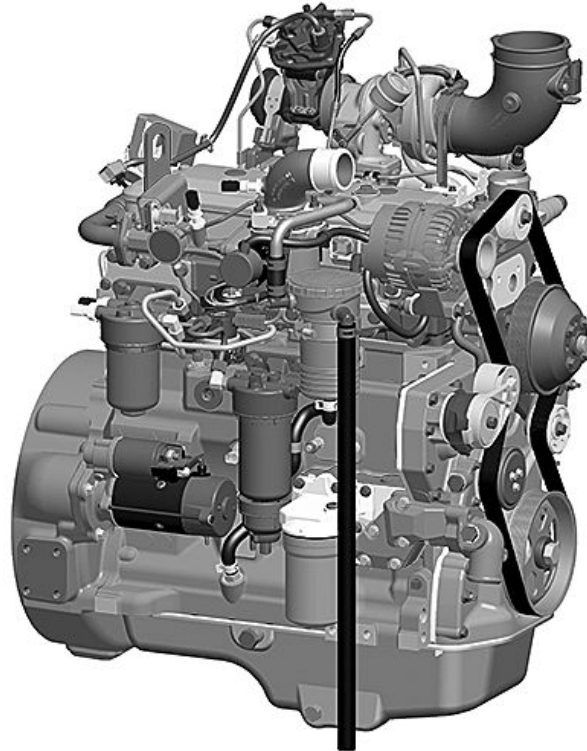

John Deere 4045 Base Engine

RG25231 —UN—10MAR14

RG25232 —UN—10MAR14

ZE59858,000007 -19-05FEB21-2/2

Trademarks

Trademarks	
AdBlue®	AdBlue is a trademark of VDA, the German Association of the Automotive Industry.
AMP®	AMP is a trademark of Tyco Electronics
BIO-GREASE-GARD™	BIO-GREASE-GARD is a trademark of Deere & Company
Bio Hy-Gard™	Bio Hy-Gard is a trademark of Deere & Company
Bluetooth®	Bluetooth is a trademark of Bluetooth SIG
Break-In™ Plus	Break-In is a trademark of Deere & Company
CINCH®	CINCH is a trademark of Cinch Inc.
COOL-GARD™ PLUS	COOL-GARD is a trademark of Deere & Company
CoolScan™	CoolScan is a trademark of Deere & Company
COOLSCAN™ PLUS	COOLSCAN is a trademark of Deere & Company
Custom Performance™	Custom Performance is a trademark of Deere & Company
Deere™	Deere is a trademark of Deere & Company
DENSO®	DENSO is a trademark of DENSO Corporation
DEUTSCH®	DEUTSCH is a trademark of TE Connectivity
DieselScan™	DieselScan is a trademark of Deere & Company
DuPont®	DuPont is a trademark of E.I. DuPont de Nemours and Company
EXTREME-GARD™	EXTREME-GARD is a trademark of Deere & Company
FleetGard™	FleetGard is a trademark of Deere & Company
Fuelscan™	Fuelscan is a trademark of Deere & Company
Funk™	Funk is a trademark of Deere & Company
GREASE-GARD™	GREASE-GARD is a trademark of Deere & Company
Hy-Gard™	Hy-Gard is a trademark of Deere & Company
JDLink™	JDLink is a trademark of Deere & Company
JDParts™	JDParts is a trademark of Deere & Company
JDPoint™	JDPoint is a trademark of Deere & Company
John Deere™	John Deere is a trademark of Deere & Company
Loctite®	Loctite is a trademark of Henkel Corporation
Metri-Pack®	Metri-Pack is a trademark of Delphi Connection Systems
OILSCAN PLUS™	OILSCAN PLUS is a trademark of Deere & Company
Oilscan™	Oilscan is a trademark of Deere & Company
Permatex®	Permatex is a trademark of Illinois Tool Works Inc.
Phoenix™	Phoenix is a trademark of Deere & Company
Plastigage®	Plastigage is a trademark of Perfect Circle Corporation
Plus-50™ II	Plus-50 is a trademark of Deere & Company
PowerSight™	PowerSight is a trademark of Deere & Company
PowerTech™	PowerTech is a trademark of Deere & Company
PowerTech™ E	PowerTech is a trademark of Deere & Company
PowerTech™ M	PowerTech is a trademark of Deere & Company
PowerTech™ Plus	PowerTech is a trademark of Deere & Company
Restore®	Restore is a trademark of "Restore, Inc."

Continued on next page

ZE59858,000006 -19-12APR21-1/2

Introduction

Scotch-Brite®	Scotch-Brite is a trademark of 3M Co.
Scotch-Grip®	Scotch-Grip is a trademark of 3M Co.
Service ADVISOR™	Service ADVISOR is a trademark of Deere & Company
SERVICEGARD™	SERVICEGARD is a trademark of Deere & Company
SPEEDI-SLEEVE®	SPEEDI-SLEEVE is a registered trademark of the SKF Group.
SWEDA™	SWEDA is a trademark of Deere & Company
Swagelok®	Swagelok is a registered trademark of Swagelok Company.
TACH-N-TIME™	TACH-N-TIME is a trademark of Bosch Automotive Service Solutions Inc.
TeamMate™	TeamMate is a trademark of Deere & Company
TEFLON®	TEFLON is a trademark of Du Pont Co.
Torq-Gard™	Torq-Gard is a trademark of Deere & Company
TORX®	TORX is a registered trademark of Acument Intellectual Properties, LLC
Vari-Cool™	Vari-Cool is a trademark of Deere & Company
WEATHER PACK®	WEATHER PACK is a trademark of Packard Electric
WINDOWS®	WINDOWS is a trademark of Microsoft Corporation

ZE59858,0000006 -19-12APR21-2/2

Contents

	Page		Page
Record Keeping			
Record Engine Serial Number.....	01-1	US EPA Qualified Emergency Use —	
Engine Option Codes	01-2	SCR Derate Override Option	05-15
Record Aftertreatment Serial Numbers	01-4		
Record High-Pressure Fuel Pump		Fuels, Lubricants, and Coolants	
Model Number.....	01-4	Diesel Exhaust Fluid (DEF) — Use in	
Record ECU Serial Number	01-5	Selective Catalytic Reduction (SCR)	
		Equipped Engines	10-1
Safety		Storing Diesel Exhaust Fluid (DEF).....	10-2
Recognize Safety Information	05-1	Diesel Exhaust Fluid (DEF) Tank Fill	
Understand Signal Words.....	05-1	Cap — Installation and Removal.....	10-3
Follow Safety Instructions.....	05-1	Refilling Diesel Exhaust Fluid (DEF) Tank.....	10-6
Replace Safety Signs	05-2	Testing Diesel Exhaust Fluid (DEF).....	10-7
Illuminate Work Area Safely	05-2	Disposal of Diesel Exhaust Fluid (DEF)	10-7
Work in Clean Area	05-2	Diesel Fuel.....	10-8
Use Proper Tools.....	05-3	Supplemental Diesel Fuel Additives	10-9
Live With Safety.....	05-3	Lubricity of Diesel Fuel	10-9
Prevent Machine Runaway.....	05-3	Handling and Storing Diesel Fuel	10-9
Handle Fuel Safely—Avoid Fires.....	05-4	Biodiesel Fuel	10-10
Prepare for Emergencies.....	05-4	Testing Diesel Fuel	10-11
Handle Starting Fluid Safely	05-4	Fuel Filters.....	10-11
In Case of Fire	05-5	Minimizing the Effect of Cold Weather	
Handle Fluids Safely—Avoid Fires.....	05-5	on Diesel Engines	10-12
Avoid Static Electricity Risk When Refueling.....	05-6	John Deere Break-In Plus™ Engine Oil	
Service Machines Safely	05-6	— Interim Tier 4, Final Tier 4, Stage	
Wear Protective Clothing.....	05-6	IIIB, Stage IV, and Stage V.....	10-13
Protect Against Noise	05-7	Diesel Engine Oil — Interim Tier 4,	
Handling Batteries Safely	05-7	Final Tier 4, Stage IIIB, Stage IV,	
Prevent Acid Burns.....	05-8	and Stage V	10-14
Stay Clear of Rotating Drivelines.....	05-8	Diesel Engine Oil and Filter Service	
Install All Guards	05-9	Intervals — Interim Tier 4, Final Tier	
Practice Safe Maintenance.....	05-9	4, Stage IIIB, Stage IV, and Stage	
Remove Paint Before Welding or Heating	05-10	V— OEM Applications.....	10-15
Avoid Heating Near Pressurized Fluid Lines	05-10	Diesel Engine Oil and Filter Service Intervals ..	10-16
Avoid High-Pressure Fluids	05-10	Mixing of Lubricants.....	10-16
Do Not Open High-Pressure Fuel System.....	05-11	Alternative and Synthetic Lubricants	10-16
Protect Against High Pressure Spray	05-11	Lubricant Storage	10-16
Prevent Battery Explosions	05-11	Oil Filters	10-17
Avoid Hot Exhaust.....	05-12	Diesel Engine Coolant (engine with	
Exhaust Filter Cleaning	05-12	wet sleeve cylinder liners).....	10-18
Work In Ventilated Area.....	05-12	Water Quality for Mixing with Coolant	
Service Cooling System Safely	05-13	Concentrate.....	10-19
Decommissioning — Proper Recycling		Operating in Warm Temperature Climates	10-19
and Disposal of Fluids and Components	05-13	Testing Coolant Freeze Point	10-20
EU Qualified Emergency Use — SCR		Disposing of Coolant	10-20
Derate Override Option	05-14		

Continued on next page

Original Instructions. All information, illustrations and specifications in this manual are based on the latest information available at the time of publication. The right is reserved to make changes at any time without notice.

COPYRIGHT © 2022
DEERE & COMPANY
Moline, Illinois
All rights reserved.
A John Deere ILLUSTRATION™ Manual
Previous Editions
Copyright © 2014, 2015, 2016, 2017, 2018, 2020, 2021

Page	Page
Instrument Panels	
PV101 Instrument Panels.....	15-1
PV101 Diagnostic Gauge — Using	15-3
PV101 Diagnostic Gauge — Main Menu.....	15-4
PV101 Diagnostic Gauge — Essential Menus ...	15-5
DG14 Diagnostic Gauge — Using	15-5
DG14 Diagnostic Gauge — Main Menu	15-6
DG14 Diagnostic Gauge — Essential Menus.....	15-7
PV480 Instrument Panel.....	15-8
PV480 Diagnostic Gauge — Using	15-9
PV480 Diagnostic Gauge — Main Menu.....	15-10
PV480 Diagnostic Gauge — Essential Menus ..	15-11
Required Machine Stop Warning.....	15-11
John Deere PowerSight.....	15-13
Engine Operation	
Break-In Service	20-1
Generator Set (Standby) Applications	20-1
Starting the Engine	20-2
Normal Engine Operation	20-3
Cold Weather Operation.....	20-4
Warming Engine	20-5
Idling Engine	20-5
Changing Engine Speed.....	20-5
Stopping the Engine	20-6
Using a Booster Battery or Charger	20-6
Auxiliary Gear Drive Limitations	20-7
Aftertreatment System	
Exhaust Filter Cleaning and Maintenance.....	25-1
Exhaust Filter — Cleaning.....	25-1
Diesel Particulate Filter Maintenance and Service	25-2
Exhaust Filter — Diesel Particulate Filter Ash Handling and Disposal	25-2
Exhaust Filter — Disposal	25-2
Exhaust Filter System Overview.....	25-3
Selective Catalytic Reduction (SCR) System Overview	25-4
Diagnostic Gauge Keys and Indicators Overview	25-6
Aftertreatment Indicators Overview	25-7
Passive Regeneration	25-8
Automatic (AUTO) Exhaust Filter Cleaning	25-8
Manual/Parked Exhaust Filter Cleaning	25-9
Disable Exhaust Filter Cleaning	25-9
Exhaust Filter Service Required	25-10
Lubrication and Maintenance	
Required Emission-Related Information.....	30-1
Observe Service Intervals	30-1
Use Correct Fuels, Lubricants, and Coolant.....	30-1
Lubrication and Maintenance Service Interval Chart.....	30-2
Lubrication & Maintenance — Daily	
Daily Prestarting Checks	35-1
Lubrication & Maintenance — 500 Hours/12 Months	
Servicing Fire Extinguisher.....	40-1
Servicing Battery	40-1
Changing Engine Oil and Replacing Filter.....	40-3
Visually Inspecting Coolant Pump	40-4
Checking Open Crankcase Vent (OCV)	40-5
Removing and Installing Fuel Filters	40-5
Checking Belt Wear	40-7
Checking Tensioner Spring Tension	40-8
Checking Cooling System	40-8
Pressure Testing Cooling System.....	40-9
Checking and Adjusting Engine Speeds	40-10
Checking Engine Mounts.....	40-10
Checking Engine Ground Connection	40-10
Lubrication & Maintenance — 1500 Hours	
Changing Open Crankcase Ventilation (OCV) Filter	45-1
Lubrication & Maintenance — 1500 Hours/36 Months	
Access DEF Tank Header	46-1
Replace Diesel Exhaust Fluid (DEF) Tank Header Suction Screen	46-1
Lubrication & Maintenance — 3000 Hours/36 Months	
Adjusting Valve Clearance.....	50-1
Testing Glow Plugs for Continuity.....	50-4
Lubrication & Maintenance — 4500 Hours/36 Months	
Access DEF Dosing Unit	51-1
Change Diesel Exhaust Fluid (DEF) Dosing Unit Filter.....	51-1
Lubrication & Maintenance — 6000 Hours/72 Months	
Flushing and Refilling Cooling System.....	60-1
Testing Thermostat Opening Temperature	60-3
Lubrication & Maintenance — 8000 Hours/36 Months	
Change Diesel Exhaust Fluid (DEF) In-Line Filter	61-1
Service As Required	
Additional Service Information.....	65-1
Do Not Modify Fuel System.....	65-1
Drain Water From Fuel Filters	65-2

Continued on next page

Page	Page		
Adding Coolant.....	65-2	Metric Bolt and Screw Torque Values.....	80-6
Cleaning Diesel Exhaust Fluid (DEF) Tank	65-3	Lubrication and Maintenance Records	
Pre-Start Cleaning Guide	65-4	Using Lubrication and Maintenance Records.....	85-1
Replacing Air Filter Element.....	65-5	Daily (Prestarting) Service.....	85-1
Inspecting Primary Air Filter Element	65-6	500 Hours of Operation or Every 12	
Air Filter Element Storage	65-6	Months Service	85-1
Cleaning the Exhaust Filter	65-7	1500 Hours of Operation Service	85-2
Replacing Fan Belt	65-8	1500 Hours of Operation or Every 36	
Checking Fuses.....	65-9	Months Service	85-2
Checking Electrical Wiring And Connections	65-9	3000 Hours of Operation or Every 36	
Bleeding Fuel System.....	65-9	Months Service	85-2
Checking Air Compressors (If Equipped)	65-9	6000 Hours of Operation or Every 72	
Compressor (If Equipped).....	65-9	Months Service	85-3
Replace Aftertreatment DEF Dosing		8000 Hours of Operation or Every 36	
System Coolant Filter.....	65-10	Months Service	85-3
DEF Tank Inlet Screen — Installation.....	65-10	Service as Required	85-3
DEF Tank Inlet Screen — Removal.....	65-11		
Troubleshooting		Warranty	
General Troubleshooting Information	70-1	John Deere Warranty in OEM Applications	90-1
Diagnostic Trouble Codes (DTCs) — Listing.....	70-2	Emissions Control System Certification Label....	90-4
Diagnostic Trouble Codes (DTCs) —		Carbon Dioxide Emissions (CO ₂)	90-5
Operation	70-5	EPA Non-road Emissions Control	
Intermittent DTC Diagnostics.....	70-5	Warranty Statement—Compression Ignition ..	90-6
Engine Troubleshooting.....	70-6	CARB Non-road Emissions Control	
Precautions for Electrical System		Warranty Statement—Compression Ignition ..	90-8
When Steam Cleaning Engine	70-18	China Emission Control Warranty	
Engine Wiring Harness Layout	70-19	Statement	90-16
Precautions For Welding	70-23		
4.5 L Wiring Diagram 1.....	70-24		
4.5 L Wiring Diagram 2.....	70-26		
4.5 L Wiring Diagram 3.....	70-28		
4.5 L Wiring Diagram 4.....	70-29		
4.5 L Wiring Diagram 5.....	70-31		
4.5 L Wiring Diagram 6.....	70-33		
4.5 L Wiring Diagram 7.....	70-35		
4.5 L Wiring Diagram 8.....	70-37		
4.5 L Wiring Diagram 8A	70-39		
4.5 L Wiring Diagram 9.....	70-41		
4.5 L Wiring Diagram 9A	70-43		
4.5 L Wiring Diagram 10.....	70-45		
4.5 L Wiring Diagram 11.....	70-47		
4.5 L Wiring Diagram 12.....	70-49		
4.5 L Wiring Diagram 13.....	70-50		
4.5 L Wiring Diagram 14.....	70-53		
Storage			
Engine Storage Guidelines.....	75-1		
Preparing Engine for Long-Term Storage.....	75-2		
Removing Engine from Long-Term Storage	75-3		
Specifications			
General OEM Engine Specifications	80-1		
Engine Power and Speed Rating			
Specifications	80-3		
Engine Crankcase Oil Fill Quantities	80-4		
Unified Inch Bolt and Screw Torque Values.....	80-5		

Record Keeping

Record Engine Serial Number

Each engine has a 13-digit John Deere engine serial number. The first two digits identify the factory that produced the engine:

- CD — Saran, France
- PE — Torreon, Mexico

1. The engine serial number plate (C) is located on the right-hand side of engine behind fuel filters.
2. Record all of the numbers and letters found on your engine serial number plate in the spaces provided below.
3. This information is very important for repair parts or warranty information.

Engine Serial Number (A)

Engine Model Number (B)

NOTE: On engine serial number (A) the seventh digit shows the emission level as follows:

- “L” for Tier 3 / Stage IIIA engines
- “R” for Interim Tier 4 / Stage IIIB engines
- “U” for Final Tier 4/ Stage IV/ Stage V

For identification of publications specific to engine model refer to the [PowerAssist App](#) or [John Deere Technical Information Store](#).



Torreon Factory Engine Serial Number Plate

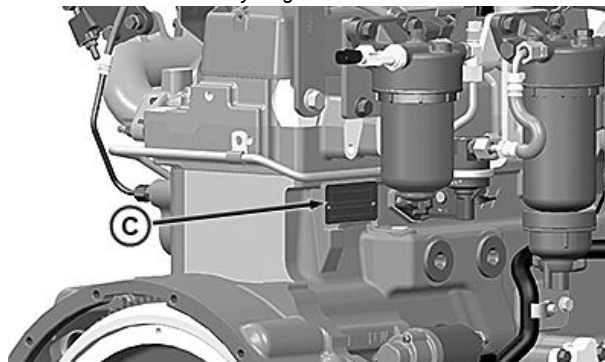

Location of Engine Serial Number Plate

RG33180 —UN—18NOV20



<https://techpubs.deere.com/>

A—Engine Serial Number
B—Engine Model Number

C—Serial Number Plate

KP41357.00000B4 -19-05FEB21-1/1

RG26229 —UN—10MAR14

RG24816 —UN—04DEC13

Engine Option Codes

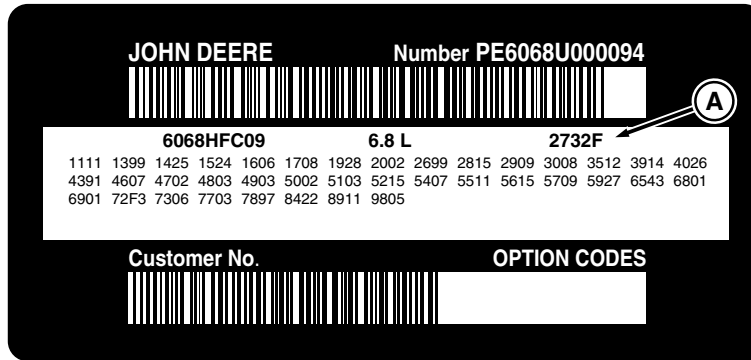

Option Code Label Example

RG24026—UN—05AUG13

A—Engine Base Code (example)

OEM engines have an engine option code label affixed to the rocker arm cover. These codes indicate which of the engine options were installed on your engine at the factory. When in need of parts or service, furnish your authorized servicing dealer or engine distributor with these numbers.

The engine option code label includes an engine base code (A). This base code must also be recorded along with the option codes. At times it will be necessary to furnish this base code to differentiate two identical option codes for the same engine model.

The first two digits of each code identify a specific group, such as alternators. The last two digits of each code identify one specific option provided on your engine, such as a 24 volt, 120 amp alternator.

If an engine is ordered without a particular component, the last two digits of that functional group option code will be 99, 00, or XX. The following list shows only the first two digits of the code numbers. For future reference such as ordering repair parts, it is important to have these code numbers available. To ensure this availability, enter the third and fourth digits shown on your engine option code label in the spaces provided on the following page.

An additional option code label may also be delivered (in a plastic bag attached to the engine or inserted in the machine documentation). It is recommended to place this label either on this page of the operator's manual or in the Engine Owner's Warranty booklet under Option Codes.

The machine manufacturer may have placed the label in a specific accessible area (inside the enclosure or close to a maintenance area).

Your engine option code label may not contain all option codes if an option has been added after the engine left the producing factory.

If option code label is lost or destroyed, consult your servicing dealer or engine distributor selling the engine for a replacement.

Record your engine Base Code (A) in the spaces provided below for easy reference.

Engine Base Code (A):

Option Codes	Description
10_____	Paint Protection
11_____	Rocker Arm Cover
12_____	Oil Filler
13_____	Crankshaft Pulley
14_____	Flywheel Housing
15_____	Flywheel
16_____	Fuel Injection System
17_____	Air Inlet
18_____	Air Cleaner
19_____	Oil Pan
20_____	Water Pump
21_____	Thermostat Cover

Option Codes	Description
56_____	Paint
57_____	Water Pump Inlet
58_____	Power Take Off
59_____	Oil Cooler/Oil Filter
60_____	Add-On Fan Drive Pulley
61_____	After Treatment Device/Muffler
62_____	Alternator Mounting
63_____	Low-Pressure Fuel Lines
64_____	Exhaust Elbow
65_____	Turbocharger
66_____	Temperature Switch
67_____	Engine Sensors

Continued on next page

RG.RG34710,5004 -19-16AUG21-1/2

Record Keeping

Option Codes	Description	Option Codes	Description
22_____	Thermostat	68_____	Damper
23_____	Fan Drive	69_____	Engine Serial Number Plate
24_____	Fan Belt	70_____	Decomposition Tube (OEM)
25_____	Fan	71_____	SCR (OEM)
26_____	Block Heater	72_____	Performance Software and Labels
27_____	Radiator/Heat Exchanger	7A_____	Performance Software and Labels
28_____	Exhaust Manifold	73_____	After Treatment Dosing System
29_____	Ventilator System	74_____	Air Conditioning
30_____	Starting Motor	75_____	Restriction Indicator
31_____	Alternator	76_____	Oil Pressure Switch
32_____	DEF Lines, Pressure (OEM)	77_____	Timing Gear Cover (S450/S650)
33_____	DEF Lines, Supply/Return to Tank (OEM)	78_____	Air Compressor
34_____	DEF Tank and Header (OEM)	79_____	Certification
35_____	Final Fuel Filter	80_____	Sea Water Pump (Marine)
36_____	Front Plate and Idler Shafts	81_____	Primary Fuel Filter/Water Separator
37_____	Fuel Transfer Pump	82_____	Ignition System (Natural Gas)
38_____	Operator Manual	83_____	Vehicle Performance Software
39_____	Thermostat Housing	84_____	Wiring Harness
40_____	Dipstick and Tube	85_____	Fuel System (Natural Gas)
41_____	Belt Driven Auxiliary Drive (Add-On Crank Pulley)	86_____	Fan Pulley
42_____	DEF Line, Supply Module to Injector (OEM)	87_____	Belt Tensioner
43_____	Starting Aid	88_____	Oil Filter
44_____	Timing Gear Cover (S350)	89_____	EGR System
44_____	Tachometer Drive Sensors (S450/S650)	90_____	Trim Software (OEM)
45_____	Secondary Balancers	91_____	Engine Installation Kit (S350)
46_____	Cylinder Block with Camshaft	92_____	Engine Test Certificate/Engine Accessories (S350)
47_____	Crankshaft/Main Bearings	92_____	Engine Installation Kit (S450)
48_____	Connecting Rods/Pistons/Liners	93_____	Emission Label
49_____	Valve Actuating Mechanism	94_____	Custom Software
50_____	Oil Pump	95_____	Parts Installed at Factory
51_____	Cylinder Head with Valves	96_____	Engine Installation Kit/Ship With (S450/S650)
52_____	Gear Driven Auxiliary Drive	96_____	ECU Wiring Harness (6125/6135)
53_____	Fuel Heater	97_____	Field Installed Items
54_____	Turbo Air Intake	98_____	Engine Lift Strap
55_____	Shipping Stand	99_____	Service Only Parts

NOTE: This is a complete option code list based on the latest information available at the time of publication. The right is reserved to make changes

at any time without notice. Your engine will not contain all option codes listed.

RG, RG34710, 5004 -19-16AUG21-2/2

Record Aftertreatment Serial Numbers

Record numbers from equipped aftertreatment devices as shown on DPF (A and B), DOC (C and D), and SCR (E and F) serial number plates. Having these numbers recorded and kept in a safe location can aid in part ordering and assist in locating stolen items in case of theft.

DPF Part Number. _____

DPF Serial Number. _____

DOC Part Number. _____

DOC Serial Number. _____

SCR Part Number. _____

SCR Serial Number. _____

- | | |
|--|---|
| A—Diesel Particulate Filter Part Number | D—Diesel Oxidation Catalyst Serial Number |
| B—Diesel Particulate Filter Serial Number | E—Selective Catalyst Reduction Part Number |
| C—Diesel Oxidation Catalyst Part Number | F—Selective Catalyst Reduction Serial Number |

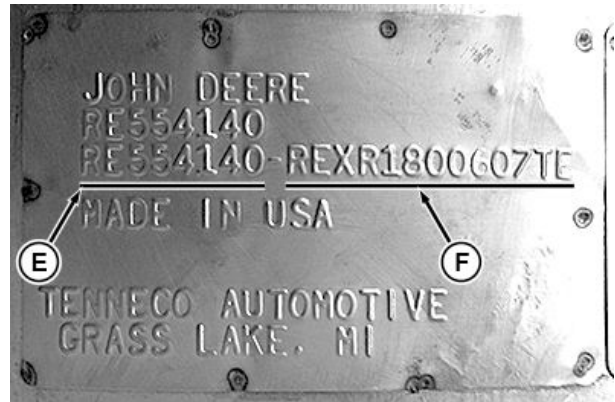
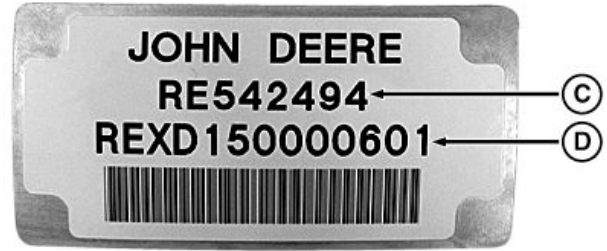

RG20010—UN—11FEB11

RG24024—UN—05AUG13

Serial Number Plates for Aftertreatment

AT89373,0000F45 -19-23NOV15-1/1

Record High-Pressure Fuel Pump Model Number

Record the high-pressure fuel pump model and serial number information found on the serial number plate (A).

Model No. _____

Manufacturer's No. _____

Serial No. _____

- A—Serial Number Plate**

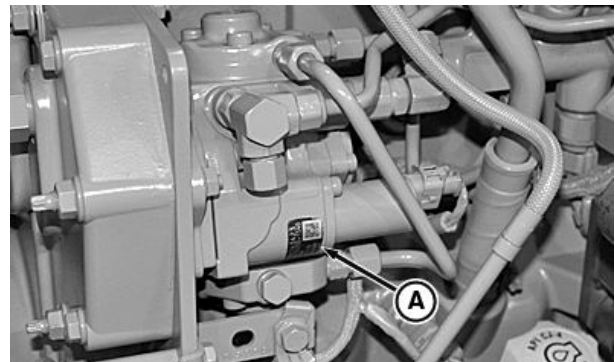

Record High-Pressure Fuel Pump Serial Number

RG20108—UN—15MAR11

ZE59858,000002C -19-28JUL14-1/1

Record ECU Serial Number

Record the part number and serial number information found on the serial number label on the Engine Control Unit (ECU).

Part No. _____

Serial No. _____

A—Serial Number Label

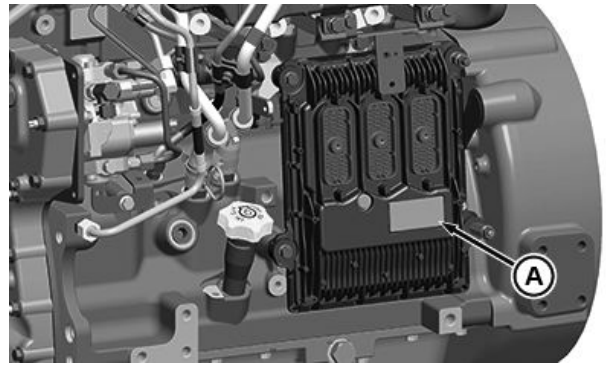

RG26249 —UN—30JUL14

ZE59858,000000C -19-12AUG14-1/1

Safety

Recognize Safety Information

This is a safety-alert symbol. When you see this symbol on your machine or in this manual, be alert to the potential for personal injury.

Follow recommended precautions and safe operating practices.

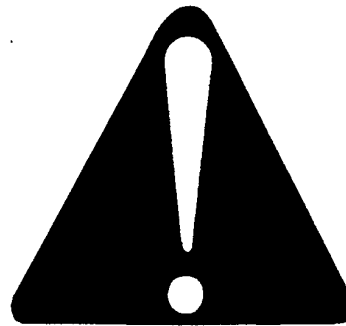

T81389 —UN—28JUN13

DX,ALERT -19-29AUG22-1/1

Understand Signal Words

DANGER; The signal word DANGER indicates a hazardous situation which, if not avoided, will result in death or serious injury.

WARNING; The signal word WARNING indicates a hazardous situation which, if not avoided, could result in death or serious injury.

CAUTION; The signal word CAUTION indicates a hazardous situation which, if not avoided, could result in minor or moderate injury. CAUTION may also be used to alert against unsafe practices associated with events which could lead to personal injury.

A signal word—DANGER, WARNING, or CAUTION—is used with the safety-alert symbol. DANGER identifies the most serious hazards. DANGER or WARNING safety signs are located near specific hazards. General

precautions are listed on CAUTION safety signs. CAUTION also calls attention to safety messages in this manual.



TS187 —19—30SEP88

DX,SIGNAL -19-05OCT16-1/1

Follow Safety Instructions

Carefully read all safety messages in this manual and on your machine safety signs. Keep safety signs in good condition. Replace missing or damaged safety signs. Be sure new equipment components and repair parts include the current safety signs. Replacement safety signs are available from your John Deere dealer.

There can be additional safety information contained on parts and components sourced from suppliers that is not reproduced in this operator's manual.

Learn how to operate the machine and how to use controls properly. Do not let anyone operate without instruction.

Keep your machine in proper working condition. Unauthorized modifications to the machine may impair the function and/or safety and affect machine life.

If you do not understand any part of this manual and need assistance, contact your John Deere dealer.



TS201 —UN—15APR13

DX,READ -19-01AUG22-1/1

Replace Safety Signs

Replace missing or damaged safety signs. Use this operator's manual for correct safety sign placement.

There can be additional safety information contained on parts and components sourced from suppliers that is not reproduced in this operator's manual.

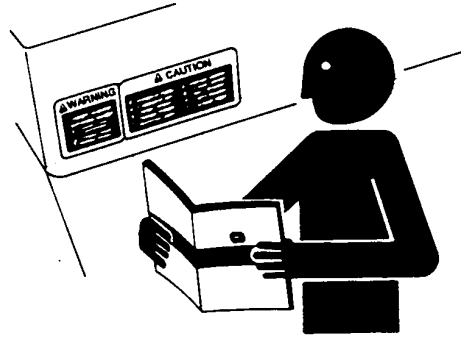

TS201 —UN—15APR13

DX,SIGNS -19-18AUG09-1/1

Illuminate Work Area Safely

Illuminate your work area adequately but safely. Use a portable safety light for working inside or under the machine. Make sure the bulb is enclosed by a wire cage. The hot filament of an accidentally broken bulb can ignite spilled fuel or oil.

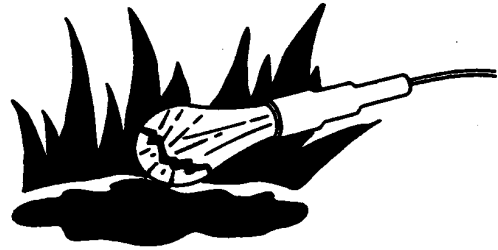

TS223 —UN—23AUG88

DX,LIGHT -19-04JUN90-1/1

Work in Clean Area

Before starting a job:

- Clean work area and machine.
- Make sure you have all necessary tools to do your job.
- Have the right parts on hand.
- Read all instructions thoroughly; do not attempt shortcuts.

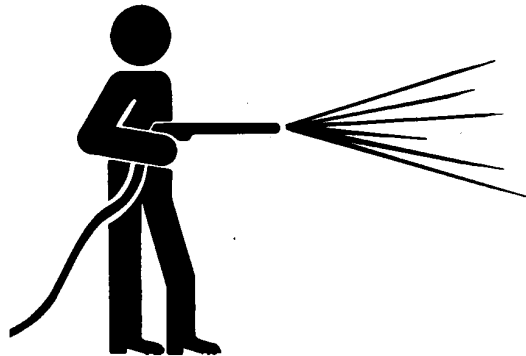

T6642EJ —UN—18OCT88

DX,CLEAN -19-04JUN90-1/1

Use Proper Tools

Use tools appropriate to the work. Makeshift tools and procedures can create safety hazards.

Use power tools only to loosen threaded parts and fasteners.

For loosening and tightening hardware, use the correct size tools. DO NOT use U.S. measurement tools on metric fasteners. Avoid bodily injury caused by slipping wrenches.

Use only service parts meeting John Deere specifications.



TS779 —UN—08NOV89

DX,REPAIR -19-17FEB99-1/1

Live With Safety

Before returning machine to customer, make sure machine is functioning properly, especially the safety systems. Install all guards and shields.



TS231 —19—07OCT88

DX,LIVE -19-25SEP92-1/1

Prevent Machine Runaway

Avoid possible injury or death from machinery runaway.

Do not start engine by shorting across starter terminals. Machine will start in gear if normal circuitry is bypassed.

NEVER start engine while standing on ground. Start engine only from operator's seat, with transmission in neutral or park.

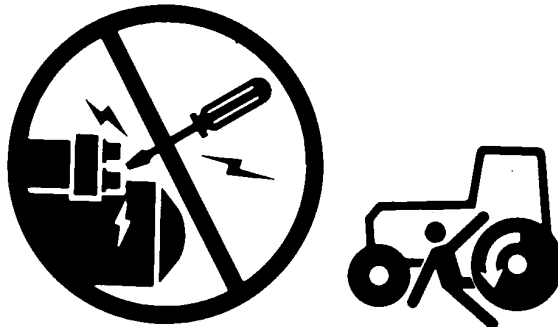

TS177 —UN—11JAN89

DX,BYPAS1 -19-29SEP98-1/1

Handle Fuel Safely—Avoid Fires

Handle fuel with care: it is highly flammable. Do not refuel the machine while smoking or when near open flame or sparks.

Always stop engine before refueling machine. Fill fuel tank outdoors.

Prevent fires by keeping machine clean of accumulated trash, grease, and debris. Always clean up spilled fuel.

Use only an approved fuel container for transporting flammable liquids.

Never fill fuel container in pickup truck with plastic bed liner. Always place fuel container on ground before refueling. Touch fuel container with fuel dispenser nozzle before removing can lid. Keep fuel dispenser nozzle in contact with fuel container inlet when filling.



Do not store fuel container where there is an open flame, spark, or pilot light such as within a water heater or other appliance.

DX,FIRE1 -19-12OCT11-1/1

TS202—UN—23AUG88

Prepare for Emergencies

Be prepared if a fire starts.

Keep a first aid kit and fire extinguisher handy.

Keep emergency numbers for doctors, ambulance service, hospital, and fire department near your telephone.

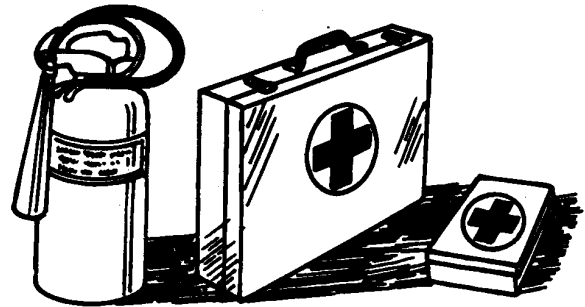

DX,FIRE2 -19-03MAR93-1/1

TS291—UN—15APR13

Handle Starting Fluid Safely

Starting fluid is highly flammable.

Keep all sparks and flame away when using it. Keep starting fluid away from batteries and cables.

To prevent accidental discharge when storing the pressurized can, keep the cap on the container, and store in a cool, protected location.

Do not incinerate or puncture a starting fluid container.

Do not use starting fluid on an engine equipped with glow plugs or an air intake heater.



DX,FIRE3 -19-14MAR14-1/1

TS1356—UN—18MAR92

In Case of Fire

CAUTION: Avoid personal injury.

Stop machine immediately at the first sign of fire. Fire may be identified by the smell of smoke or sight of flames. Because fire grows and spreads rapidly, get off the machine immediately and move safely away from the fire. Do not return to the machine! The number one priority is safety.

Call the fire department. A portable fire extinguisher can put out a small fire or contain it until the fire department arrives; but portable extinguishers have limitations. Always put the safety of the operator and bystanders first. If attempting to extinguish a fire, keep your back to the wind with an unobstructed escape path so you can move away quickly if the fire cannot be extinguished.

Read the fire extinguisher instructions and become familiar with their location, parts, and operation before a fire starts. Local fire departments or fire equipment distributors may offer fire extinguisher training and recommendations.

If your extinguisher does not have instructions, follow these general guidelines:



1. Pull the pin. Hold the extinguisher with the nozzle pointing away from you, and release the locking mechanism.
2. Aim low. Point the extinguisher at the base of the fire.
3. Squeeze the lever slowly and evenly.
4. Sweep the nozzle from side-to-side.

DX,FIRE4 -19-22AUG13-1/1

TS227 —UN—15APR13

Handle Fluids Safely—Avoid Fires

When you work around fuel, do not smoke or work near heaters or other fire hazards.

Store flammable fluids away from fire hazards. Do not incinerate or puncture pressurized containers.

Make sure machine is clean of trash, grease, and debris.

Do not store oily rags; they can ignite and burn spontaneously.



DX,FLAME -19-29SEP98-1/1

TS227 —UN—15APR13

Avoid Static Electricity Risk When Refueling

The removal of sulfur and other compounds in Ultra-Low Sulfur Diesel (ULSD) fuel decreases its conductivity and increases its ability to store a static charge.

Refineries may have treated the fuel with a static dissipating additive. However, there are many factors that can reduce the effectiveness of the additive over time.

Static charges can build up in ULSD fuel while it is flowing through fuel delivery systems. Static electricity discharge when combustible vapors are present could result in a fire or explosion.

Therefore, it is important to ensure that the entire system used to refuel your machine (fuel supply tank, transfer pump, transfer hose, nozzle, and others) is properly grounded and bonded. Consult with your fuel or fuel system supplier to ensure that the delivery system is in compliance with fueling standards for proper grounding and bonding practices.

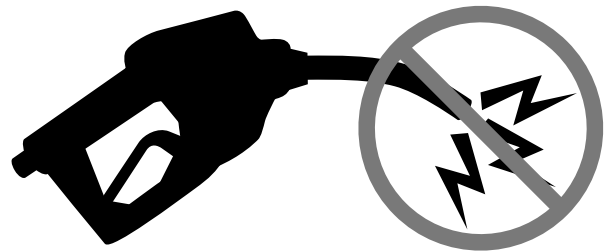

RG22142 —UN—17MAR14

RG21992 —UN—21AUG13

DX,FUEL,STATIC,ELEC -19-12JUL13-1/1

Service Machines Safely

Tie long hair behind your head. Do not wear a necktie, scarf, loose clothing, or necklace when you work near machine tools or moving parts. If these items were to get caught, severe injury could result.

Remove rings and other jewelry to prevent electrical shorts and entanglement in moving parts.

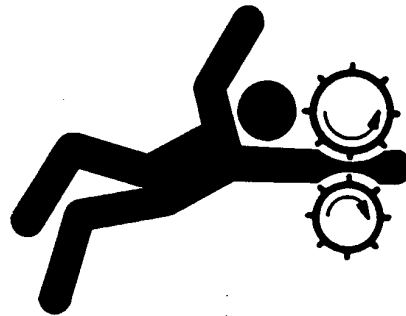

TS228 —UN—23AUG88

DX,LOOSE -19-04JUN90-1/1

Wear Protective Clothing

Wear close fitting clothing and safety equipment appropriate to the job.

Operating equipment safely requires the full attention of the operator. Do not wear radio or music headphones while operating machine.

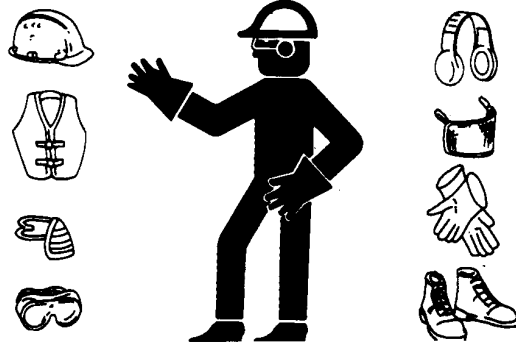

TS206 —UN—15APR13

DX,WEAR2 -19-03MAR93-1/1

Protect Against Noise

There are many variables that affect the sound level range, including machine configuration, condition and maintenance level of the machine, ground surface, operating environmental, duty cycles, ambient noise, and attachments.

Exposure to loud noise can cause impairment or loss of hearing.

Always wear hearing protection. Wear a suitable hearing protective device such as earmuffs or earplugs to protect against objectionable or uncomfortable loud noises.

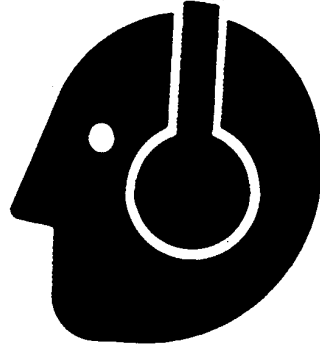

TS207 —UN—23AUG88

DX,NOISE -19-03OCT17-1/1

Handling Batteries Safely

Battery gas can explode. Keep sparks and flames away from batteries. Use a flashlight to check battery electrolyte level.

Never check battery charge by placing a metal object across the posts. Use a voltmeter or hydrometer.

Always remove grounded (-) battery clamp first and replace grounded clamp last.

Sulfuric acid in battery electrolyte is poisonous and strong enough to burn skin, eat holes in clothing, and cause blindness if splashed into eyes.

Avoid hazards by:

- Filling batteries in a well-ventilated area
- Wearing eye protection and rubber gloves
- Avoiding use of air pressure to clean batteries
- Avoiding breathing fumes when electrolyte is added
- Avoiding spilling or dripping electrolyte
- Using correct battery booster or charger procedure.

If acid is spilled on skin or in eyes:

1. Flush skin with water.
2. Apply baking soda or lime to help neutralize the acid.
3. Flush eyes with water for 15—30 minutes. Get medical attention immediately.

If acid is swallowed:

1. Do not induce vomiting.
2. Drink large amounts of water or milk, but do not exceed 2 L (2 qt.).
3. Get medical attention immediately.

WARNING: Battery posts, terminals, and related accessories contain lead and lead compounds, chemicals known to the State of California to cause cancer and reproductive harm. **Wash hands after handling.**



TS204 —UN—15APR13

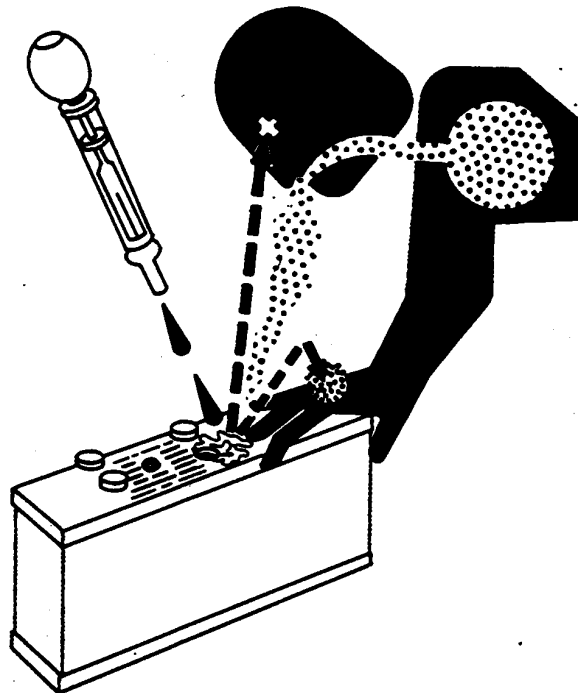

TS203 —UN—23AUG88

DX,WW,BATTERIES -19-02DEC10-1/1

Prevent Acid Burns

Sulfuric acid in battery electrolyte is poisonous. It is strong enough to burn skin, eat holes in clothing, and cause blindness if splashed into eyes.

Avoid the hazard by:

1. Filling batteries in a well-ventilated area.
2. Wearing eye protection and rubber gloves.
3. Avoiding breathing fumes when electrolyte is added.
4. Avoiding spilling or dripping electrolyte.
5. Use proper jump start procedure.

If you spill acid on yourself:

1. Flush your skin with water.
2. Apply baking soda or lime to help neutralize the acid.
3. Flush your eyes with water for 15—30 minutes. Get medical attention immediately.

If acid is swallowed:

1. Do not induce vomiting.
2. Drink large amounts of water or milk, but do not exceed 2 L (2 quarts).
3. Get medical attention immediately.



TS203—UN—23AUG88

DX,POISON -19-21APR93-1/1

Stay Clear of Rotating Drivelines

Entanglement in rotating driveline can cause serious injury or death.

Keep all shields in place at all times. Make sure rotating shields turn freely.

Wear close-fitting clothing. Stop the engine and be sure that all rotating parts and drivelines are stopped before making adjustments, connections, or performing any type of service on engine or machine driven equipment.



TS1644—UN—22AUG95

DX,ROTATING -19-18AUG09-1/1

Install All Guards

Rotating cooling system fans, belts, pulleys, and drives can cause serious injury.

Keep all guards in place at all times during engine operation.

Wear close-fitting clothes. Stop the engine and be sure fans, belts, pulleys, and drives are stopped before making adjustments, connections, or cleaning near fans and their drive components.

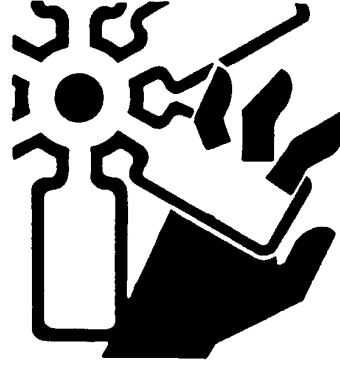

TS677 —UN—21SEP89

DX, GUARDS -19-18AUG09-1/1

Practice Safe Maintenance

Understand service procedure before doing work. Keep area clean and dry.

Never lubricate, service, or adjust machine while it is moving. Keep hands, feet, and clothing away from power-driven parts. Disengage all power and operate controls to relieve pressure. Lower equipment to the ground. Stop the engine. Remove the key. Allow machine to cool.

Securely support any machine elements that must be raised for service work.

Keep all parts in good condition and properly installed. Fix damage immediately. Replace worn or broken parts. Remove any buildup of grease, oil, or debris.

On self-propelled equipment, disconnect battery ground cable (-) before making adjustments on electrical systems or welding on machine.

On towed implements, disconnect wiring harnesses from tractor before servicing electrical system components or welding on machine.

Falling while cleaning or working at height can cause serious injury. Use a ladder or platform to easily reach each location. Use sturdy and secure footholds and handholds.



TS218 —UN—23AUG88

DX, SERV -19-28FEB17-1/1

Remove Paint Before Welding or Heating

Avoid potentially toxic fumes and dust.

Hazardous fumes can be generated when paint is heated by welding, soldering, or using a torch.

Remove paint before heating:

- Remove paint a minimum of 100 mm (4 in.) from area to be affected by heating. If paint cannot be removed, wear an approved respirator before heating or welding.
- If you sand or grind paint, avoid breathing the dust. Wear an approved respirator.
- If you use solvent or paint stripper, remove stripper with soap and water before welding. Remove solvent or paint stripper containers and other flammable material from area. Allow fumes to disperse at least 15 minutes before welding or heating.

Do not use a chlorinated solvent in areas where welding will take place.



Do all work in an area that is well ventilated to carry toxic fumes and dust away.

Dispose of paint and solvent properly.

DX,PAINT -19-24JUL02-1/1

TS220 —UN—15APR13

Avoid Heating Near Pressurized Fluid Lines

Flammable spray can be generated by heating near pressurized fluid lines, resulting in severe burns to yourself and bystanders. Do not heat by welding, soldering, or using a torch near pressurized fluid lines or other flammable materials. Pressurized lines can accidentally burst when heat goes beyond the immediate flame area.



DX,TORCH -19-10DEC04-1/1

TS953 —UN—15MAY90

Avoid High-Pressure Fluids

Inspect hydraulic hoses periodically – at least once per year – for leakage, kinking, cuts, cracks, abrasion, blisters, corrosion, exposed wire braid or any other signs of wear or damage.

Replace worn or damaged hose assemblies immediately with John Deere approved replacement parts.

Escaping fluid under pressure can penetrate the skin causing serious injury.

Avoid the hazard by relieving pressure before disconnecting hydraulic or other lines. Tighten all connections before applying pressure.

Search for leaks with a piece of cardboard. Protect hands and body from high-pressure fluids.

If an accident occurs, see a doctor immediately. Any fluid injected into the skin must be surgically removed within

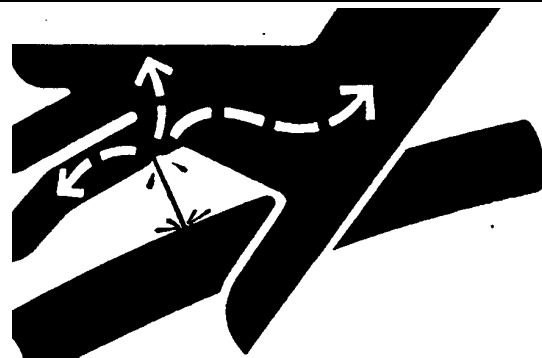

a few hours or gangrene may result. Doctors unfamiliar with this type of injury should reference a knowledgeable medical source. Such information is available in English from Deere & Company Medical Department in Moline, Illinois, U.S.A., by calling 1-800-822-8262 or +1 309-748-5636.

DX,FLUID -19-12OCT11-1/1

X9811 —UN—23AUG88

Do Not Open High-Pressure Fuel System

High-pressure fluid remaining in fuel lines can cause serious injury. Do not disconnect or attempt repair of fuel lines, sensors, or any other components between the high-pressure fuel pump and nozzles on engines with High Pressure Common Rail (HPCR) fuel system.

Only technicians familiar with this type of system can perform repairs. (See your John Deere dealer.)



TS1343—UN—18MAR92

DX,WW,HPCR1 -19-07JAN03-1/1

Protect Against High Pressure Spray

Spray from high pressure nozzles can penetrate the skin and cause serious injury. Keep spray from contacting hands or body.

If an accident occurs, see a doctor immediately. Any high pressure spray injected into the skin must be surgically removed within a few hours or gangrene may result. Doctors unfamiliar with this type of injury should reference a knowledgeable medical source. Such information is available from Deere & Company Medical Department in Moline, Illinois, U.S.A.



TS1343—UN—18MAR92

DX,SPRAY -19-16APR92-1/1

Prevent Battery Explosions

Keep sparks, lighted matches, and open flame away from the top of battery. Battery gas can explode.

Never check battery charge by placing a metal object across the posts. Use a volt-meter or hydrometer.

Do not charge a frozen battery; it may explode. Warm battery to 16°C (60°F).



TS204—UN—15APR13

DX,SPARKS -19-03MAR93-1/1

Avoid Hot Exhaust

Servicing machine or attachments with engine running can result in serious personal injury. Avoid exposure and skin contact with hot exhaust gases and components.

Exhaust parts and streams become very hot during operation. Exhaust gases and components reach temperatures hot enough to burn people, ignite, or melt common materials.

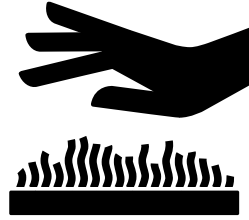

RG17488 —UN—21AUG09

DX,EXHAUST -19-20AUG09-1/1

Exhaust Filter Cleaning

Servicing machine or attachments during exhaust filter cleaning can result in serious personal injury. Avoid exposure and skin contact with hot exhaust gases and components.

During auto or manual/stationary exhaust filter cleaning operations, the engine will run at elevated idle and hot temperatures for an extended period of time. Exhaust gases and exhaust filter components reach temperatures hot enough to burn people, or ignite, or melt common materials.

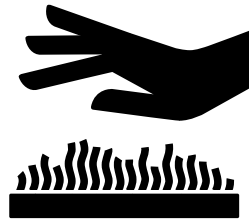

RG17488 —UN—21AUG09

DX,FILTER -19-20JAN10-1/1

Work In Ventilated Area

Engine exhaust fumes can cause sickness or death. If it is necessary to run an engine in an enclosed area, remove the exhaust fumes from the area with an exhaust pipe extension.

If you do not have an exhaust pipe extension, open the doors and get outside air into the area.

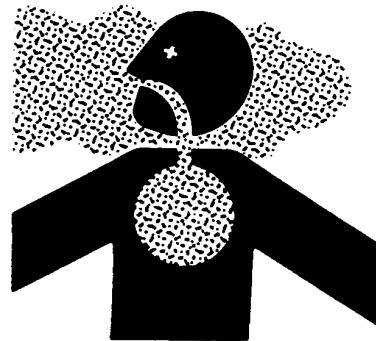

TS220 —UN—15APR13

DX,AIR -19-17FEB99-1/1

Service Cooling System Safely

Explosive release of fluids from pressurized cooling system can cause serious burns.

Shut off engine. Only remove filler cap when cool enough to touch with bare hands. Slowly loosen cap to first stop to relieve pressure before removing completely.



TS281 —UN—15APR13

DX,WW,COOLING -19-19AUG09-1/1

Decommissioning — Proper Recycling and Disposal of Fluids and Components

Safety and environmental stewardship measures must be taken into account when decommissioning a machine and/or component. These measures include the following:

- Use appropriate tools and personal protective equipment such as clothing, gloves, face shields or glasses, during the removal or handling of objects and materials.
- Follow instructions for specialized components.
- Release stored energy by lowering suspended machine elements, relaxing springs, disconnecting the battery or other electrical power, and releasing pressure in hydraulic components, accumulators, and other similar systems.
- Minimize exposure to components which may have residue from agricultural chemicals, such as fertilizers and pesticides. Handle and dispose of these components appropriately.
- Carefully drain engines, fuel tanks, radiators, hydraulic cylinders, reservoirs, and lines before recycling components. Use leak-proof containers when draining fluids. Do not use food or beverage containers.
- Do not pour waste fluids onto the ground, down a drain, or into any water source.
- Observe all national, state, and local laws, regulations, or ordinances governing the handling or disposal of waste fluids (example: oil, fuel, coolant, brake fluid);

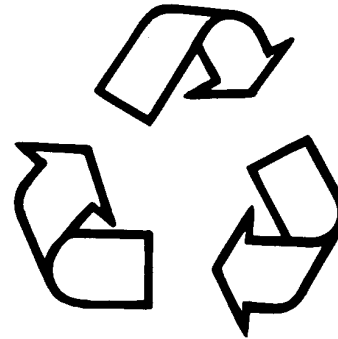

TS1133 —UN—15APR13

- filters; batteries; and, other substances or parts. Burning of flammable fluids or components in other than specially designed incinerators may be prohibited by law and could result in exposure to harmful fumes or ashes.
- Service and dispose of air conditioning systems appropriately. Government regulations may require a certified service center to recover and recycle air conditioning refrigerants which could damage the atmosphere if allowed to escape.
 - Evaluate recycling options for tires, metal, plastic, glass, rubber, and electronic components which may be recyclable, in part or completely.
 - Contact your local environmental or recycling center, or your John Deere dealer for information on the proper way to recycle or dispose of waste.

DX,DRAIN -19-01JUN15-1/1

EU Qualified Emergency Use — SCR Derate Override Option

NOTE: This is an EU only option.

IMPORTANT: Operating the engine without emissions related derates could damage the aftertreatment system.

Description: EU Qualified Emergency Use – SCR Derate Override Option

Under the EU regulations, this engine may be fitted with a means to disable the operator inducement (SCR Derate Override) during a qualified emergency. Using this option is only permitted during an emergency declared by a national or regional government, their emergency services, or their armed services. Any activation will be recorded in the on-board computer log and national inspection authorities will be able to read these records with a scan tool.

Emergency SCR Derate Override enables a Selective Catalyst Reduction (SCR) equipped application to operate without emissions-related derates for a specified period of time during qualified emergency situations. A qualified emergency situation is one in which the condition of an engine's emission controls poses a significant direct or indirect risk to human life. An example of a direct risk is an emission control condition that inhibits the performance of an engine being used to rescue a person from a life-threatening situation. An example of an indirect risk is an emission control condition that inhibits the performance of an engine being used to provide electrical power to a data center that routes "911" emergency response telecommunications.

Emergency SCR Derate Override Activation / Reporting

The operator can activate the Emergency SCR Derate Override through the operator interface. Once activated, the engine can operate free of emissions-related derates for 120 hours. If the derate condition is corrected during

the 120 hours, the Emergency SCR Derate Override can be paused in order to preserve the remainder of time for future use. The option expires along with any remaining time 240 hours after the Emergency SCR Derate Override is activated.

When the Emergency SCR Derate Override has expired, the engine informational Diagnostic Trouble Code (DTC) is displayed to the operator upon every engine start and every hour until acknowledged by the operator. To clear the DTC and reset the Emergency SCR Derate Override timer for future use, the operator (or other person responsible for the engine/equipment) must submit a report to the John Deere Dealer Technical Assistance Center, which must include the following:

- Contact name, mail and email addresses, and telephone number for responsible company or entity
- Description of the emergency situation, the location of the engine during the emergency, and the contact information for an official who can verify the emergency situation (such as a county sheriff, fire marshal, or hospital administrator)
- Reason for the Emergency SCR Derate Override activation during the emergency situation, such as the lack of diesel exhaust fluid, or the failure of an emission-related sensor when the engine was needed to respond to an emergency situation
- Engine's serial number
- Description of the extent and duration of the engine operation while the Emergency SCR Derate Override was active, including a statement describing whether or not the Override was manually deactivated after the emergency situation ended

In no event may this report be submitted to John Deere or other qualified service provide later than 60 calendar days after the Emergency SCR Derate Override is activated.

LEGAL Notification

Any activation will be recorded in the on-board computer log and national inspection authorities will be able to read these records with a scan tool.

DX,SCR,EMRGNCY,OVERIDE,EU -19-19JAN18-1/1

US EPA Qualified Emergency Use — SCR Derate Override Option

NOTE: This is a US EPA only option.

IMPORTANT: Operating the engine without emissions related derates could damage the aftertreatment system.

Description: US EPA Qualified Emergency Use – SCR Derate Override Option

Under the US EPA's regulations the Qualified Emergency SCR Derate Override Option (Emergency SCR Derate Override) is considered an Auxiliary Emission Control Device (AECDD), which is only permitted during qualified emergency situations. To ensure compliance with US EPA regulations governing this type of AECDD it is important that operators read the following information and comply with the requirements.

Emergency SCR Derate Override enables a Selective Catalyst Reduction (SCR) equipped application to operate without emissions-related derates for a specified period of time during qualified emergency situations. A qualified emergency situation is one in which the condition of an engine's emission controls poses a significant direct or indirect risk to human life. An example of a direct risk is an emission control condition that inhibits the performance of an engine being used to rescue a person from a life-threatening situation. An example of an indirect risk is an emission control condition that inhibits the performance of an engine being used to provide electrical power to a data center that routes "911" emergency response telecommunications.

Emergency SCR Derate Override Activation / Reporting

The operator can activate the Emergency SCR Derate Override through the operator interface. Once activated, the engine can operate free of emissions-related derates for 120 hours. If the derate condition is corrected during the 120 hours, the Emergency SCR Derate Override can be paused in order to preserve the remainder of time for future use. The option expires along with any remaining time 240 hours after the Emergency SCR Derate Override is activated.

When the Emergency SCR Derate Override has expired, the engine informational Diagnostic Trouble Code (DTC) is displayed to the operator upon every engine start and every hour until acknowledged by the operator. To clear the DTC and reset the Emergency SCR Derate

Override timer for future use, the operator (or other person responsible for the engine/equipment) must submit a report to the John Deere Dealer Technical Assistance Center, which must include the following:

- Contact name, mail and email addresses, and telephone number for responsible company or entity
- Description of the emergency situation, the location of the engine during the emergency, and the contact information for an official who can verify the emergency situation (such as a county sheriff, fire marshal, or hospital administrator)
- Reason for the Emergency SCR Derate Override activation during the emergency situation, such as the lack of diesel exhaust fluid, or the failure of an emission-related sensor when the engine was needed to respond to an emergency situation
- Engine's serial number
- Description of the extent and duration of the engine operation while the Emergency SCR Derate Override was active, including a statement describing whether or not the Override was manually deactivated after the emergency situation ended

In no event may this report be submitted to John Deere or other qualified service provide later than 60 calendar days after the Emergency SCR Derate Override is activated.

LEGAL Notification

The following actions by the operator are an improper use of the Emergency SCR Derate Override and are prohibited by the Clean Air Act and US EPA regulations:

- Activating the Emergency SCR Derate Override for something other than a qualified emergency situation;
- Failing to disable the Emergency SCR Derate Override after a qualified emergency situation ends; and,
- Failing to notify John Deere and send it reports as required in this Operators Manual and federal regulations. Note: John Deere is required to report to the US EPA the operator's failure to report to it any Emergency SCR Derate Override event (to the extent it becomes aware of such event).

The maximum civil penalty the US EPA may assess under 40 CFR 1068.101 is \$4,454 for each day an engine or piece of equipment is operated in violation of the requirements associated with the Emergency SCR Derate Override.

US EPA regulations governing the Emergency SCR Derate Override can be found at 40 CFR §1039.665, as may be amended.

DX,SCR,EMRGNCY,OVERIDE,US -19-24JAN18-1/1

Fuels, Lubricants, and Coolants

Diesel Exhaust Fluid (DEF) — Use in Selective Catalytic Reduction (SCR) Equipped Engines

In order to maintain the emissions performance of the engine, it is essential to use and refill DEF in accordance with the specification.

RG30211 —UN—08MAR18

Diesel exhaust fluid (DEF) is a high purity liquid that is injected into the exhaust system of engines equipped with selective catalytic reduction (SCR) systems. Maintaining the purity of DEF is important to avoid malfunctions in the SCR system. Engines requiring DEF shall use a product that meets the requirements for aqueous urea solution 32 (AUS 32) according to ISO 22241-1.



The use of John Deere Diesel Exhaust Fluid is recommended. John Deere Diesel Exhaust Fluid is available at your John Deere dealer in a variety of package sizes to suit your operational needs.

In some cases, DEF is referred to by one or more of these names:

- Urea
- Aqueous Urea Solution 32
- AUS 32
- AdBlue™
- NOx Reduction Agent
- Catalyst Solution

If John Deere Diesel Exhaust Fluid is not available, use DEF that is certified by the American Petroleum Institute (API) Diesel Exhaust Fluid Certification Program or by the AdBlue™ Diesel Exhaust Fluid Certification Program. Look for the API certification symbol or the AdBlue™ name on the container.

AdBlue is a trademark of VDA, the German Association of the Automotive Industry.

DX,DEF -19-13JAN18-1/1

Storing Diesel Exhaust Fluid (DEF)

⚠ CAUTION: Avoid contact with eyes. In case of contact, immediately flush eyes with large amounts of water for a minimum of 15 minutes. Reference the Materials Safety Data Sheet (MSDS) for additional information.

Do not ingest DEF. In the event DEF is ingested, contact a physician immediately. Reference the Materials Safety Data Sheet (MSDS) for additional information.

IMPORTANT: It is unlawful to tamper with or remove any component of the aftertreatment system. Do not use DEF that does not meet the required specifications or operate the engine with no DEF.

Never attempt to create DEF by mixing agricultural grade urea with water. Agricultural grade urea does not meet the necessary specifications and can damage the aftertreatment system.

Do not add any chemicals or additives to DEF in an effort to prevent freezing. Any chemicals or additives added to DEF can damage the aftertreatment system.

Never add water or any other fluid in place of, or in addition to DEF. Operating with a modified DEF or using an unapproved DEF can damage the aftertreatment system.

Storage information provided below is for reference and is to be used as a guideline only.

It is preferred to store DEF out of extreme ambient temperatures. DEF freezes at -11°C (12°F). Exposure to temperatures greater than 30°C (86°F) can degrade DEF over time. Do not store DEF in direct sunlight.

Dedicated DEF storage containers must be sealed between uses to prevent evaporation and contamination. Containers made of polyethylene, polypropylene, or stainless steel are recommended to transport and store DEF.

Ideal conditions for storage of DEF are:

- Store at temperatures between -5°C and 30°C (23°F and 86°F)
- Store in dedicated containers sealed to avoid contamination and evaporation

Under these conditions, DEF is expected to remain useable for a minimum of 18 months. Storing DEF at higher temperatures can reduce its useful life by approximately 6 months for every 5°C (9°F) temperature above 30°C (86°F).

If unsure how long or under what conditions DEF has been stored, test DEF. See Testing Diesel Exhaust Fluid (DEF).

Long-term storage in the DEF tank (over 12 months) is not recommended. If long-term storage is necessary, test DEF prior to operating engine. See Testing Diesel Exhaust Fluid (DEF).

It is recommended to purchase DEF in quantities that will be consumed within 12 months.

DX,DEF,STORE -19-15JUL20-1/1

Diesel Exhaust Fluid (DEF) Tank Fill Cap — Installation and Removal

There are locking and non-locking DEF tank fill caps. Use the appropriate procedure.

⚠ CAUTION: Avoid contact with eyes. In case of contact, immediately flush eyes with large amounts of water for a minimum of 15 minutes. Reference the Materials Safety Data Sheet (MSDS) for additional information.

Do not ingest DEF. In the event DEF is ingested, contact a physician immediately. Reference the Materials Safety Data Sheet (MSDS) for additional information.

IMPORTANT: Thoroughly clean the DEF filler cap and the area around the tank fill neck.

Use only distilled water to rinse components that are used to deliver DEF. Tap water can contaminate DEF. If distilled water is not available, rinse with clean tap water, then thoroughly rinse with ample amounts of DEF.

If DEF is spilled or contacts any surface other than the storage tank, immediately clean the

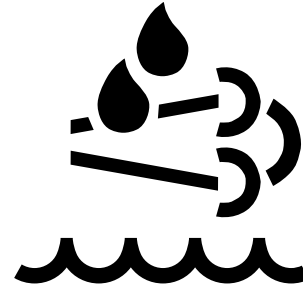

surface with clear water. DEF is corrosive to painted and unpainted metallic surfaces and can distort some plastic and rubber components.

IMPORTANT: Avoid damage to components. **DO NOT** use excessive force. Improper installation will result in damage to the DEF tank fill cap.

Reasonable care should be taken when opening the DEF tank. Ensure that the DEF tank cap area is free of debris before removing the cap. Close the tank and any containers of DEF between use to prevent contamination and evaporation.

Continued on next page

MH42591.00000A5 -19-11MAR21-1/3

TS1731 —UN—23AUG13

Non-Locking DEF Tank Fill Cap

Cap Removal

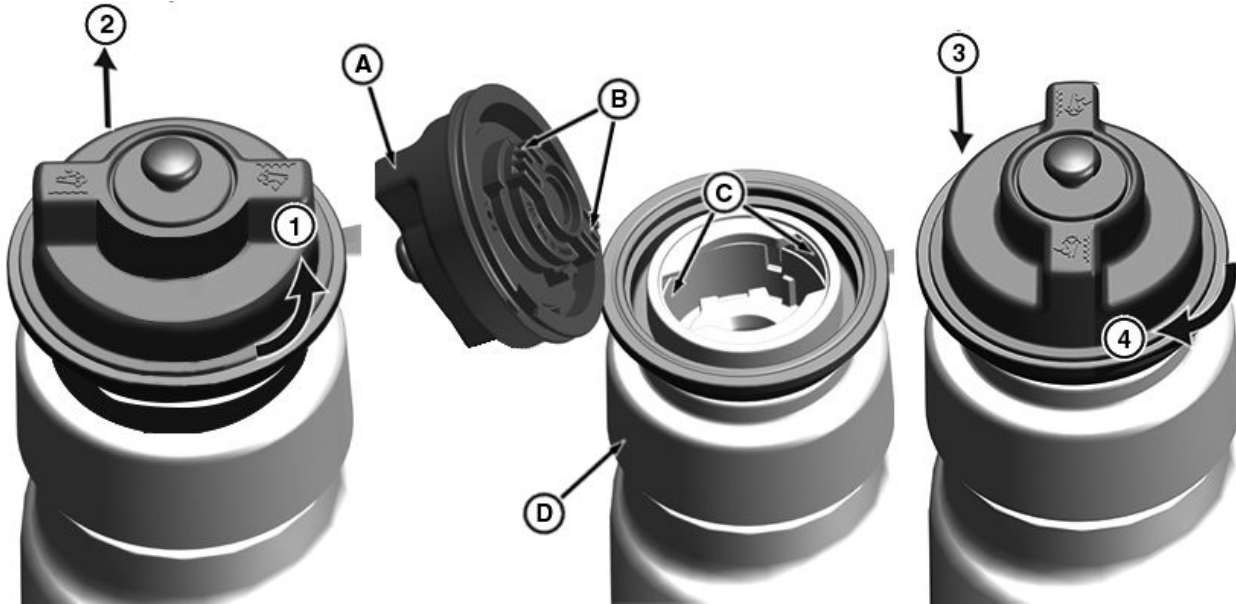

Non-Locking DEF Fill Cap

RG33544 —UN—01MAR21

1— Counterclockwise Rotation
(¼ turn, 90°)
2— Straight Up

3— Straight Down
4— Clockwise Rotation (¼ turn,
90°)

A—Non-Locking Fill Cap
B—Alignment Tab (2 used)

C—Slot (2 used)
D—Filler Neck

1. Rotate non-locking fill cap (A) counterclockwise, one quarter turn 90° (1).
2. Lift non-locking fill cap (A) straight up (2) and out of the DEF filler neck (D).

1. Align tabs (B) of the non-locking fill cap (A) with the slots (C) of the DEF filler neck (D).
2. Install non-locking fill cap (A) straight down (3) into the DEF filler neck (D) until it is completely seated.
3. Hold non-locking fill cap (A) straight down (3) while rotating clockwise one quarter turn 90° (4). DO NOT use excessive force or overtighten fill cap.

Cap Installation

IMPORTANT: Avoid damage to components. DO NOT use excessive force. ENSURE alignment tabs (B) are properly aligned with the slots (C) in filler neck (D). DO NOT use excessive force or overtighten. If resistance is felt, then realign the cap before tightening.

Continued on next page

MH42591,00000A5 -19-11MAR21-2/3

Locking DEF Tank Fill Cap

Cap Removal

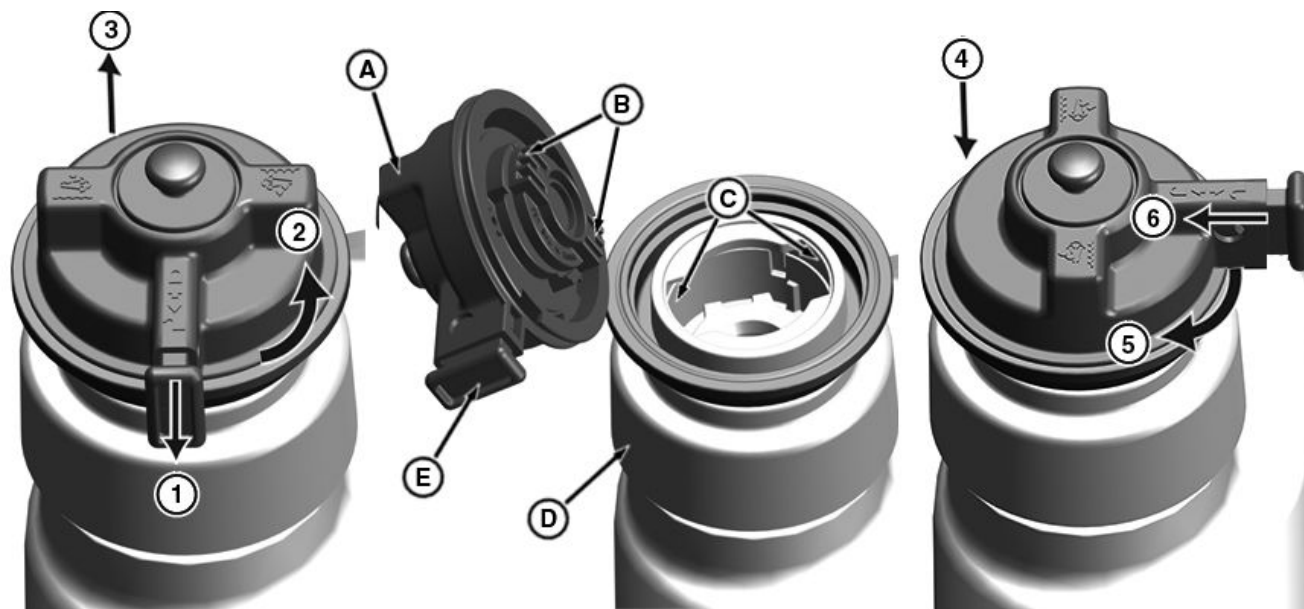

Locking Fill Cap

- | | | | |
|--|-------------------------------------|---------------------------|------------------|
| 1— Locking Tab Disengagement | 3— Straight Up | 6— Locking Tab Engagement | C— Slot (2 used) |
| 2— Counterclockwise Rotation (¼ turn, 90°) | 4— Straight Down | A— Locking Fill Cap | D— Filler Neck |
| | 5— Clockwise Rotation (¼ turn, 90°) | B— Alignment Tab (2 used) | E— Locking Tab |

IMPORTANT: Avoid damage to components. DO NOT use excessive force. ENSURE locking tab is fully disengaged before attempting to rotate. DO NOT use excessive force to remove fill cap.

- Slide locking tab (E) out as shown to disengage (1) the locking tab.
- Rotate locking fill cap (A) counterclockwise one quarter turn 90° (2).
- Lift locking fill cap (A) straight up (3) and out of the DEF filler neck (D).

Cap Installation

- Align tabs (B) of the locking fill cap (A) with the slots (C) of the DEF filler neck (D).

- Install locking fill cap (A) straight down (4) into the DEF filler neck (D) until it is completely seated.

IMPORTANT: Avoid damage to components. DO NOT use excessive force. ENSURE alignment tabs (B) are properly aligned with the slots (C) in filler neck (D). DO NOT use excessive force or overtighten. If resistance is felt, then realign the cap before tightening.

- Hold locking fill cap (A) straight down (4) while rotating clockwise one quarter turn 90° (5). DO NOT use excessive force or overtighten fill cap.
- Slide locking tab (E) inward to engage (6) as shown to lock fill cap.

MH42591,00000A5 -19-11MAR21-3/3

RG33526 —UN—08MAR21

Refilling Diesel Exhaust Fluid (DEF) Tank

⚠ CAUTION: Avoid contact with eyes. In case of contact, immediately flush eyes with large amounts of water for a minimum of 15 minutes. Reference the Materials Safety Data Sheet (MSDS) for additional information.

Do not ingest DEF. In the event DEF is ingested, contact a physician immediately. Reference the Materials Safety Data Sheet (MSDS) for additional information.

IMPORTANT: Use only distilled water to rinse components that are used to deliver DEF. Tap water can contaminate DEF. If distilled water is not available, rinse with clean tap water, then thoroughly rinse with ample amounts of DEF.

If DEF is spilled or contacts any surface other than the storage tank, immediately clean the surface with clear water. DEF is corrosive to painted and unpainted metallic surfaces and can distort some plastic and rubber components.

If DEF is filled into engine fuel tank or other fluid compartment, do not operate engine until system is properly purged of DEF. Contact your John Deere dealer immediately to determine how to clean and purge the system.

Reasonable care should be taken when refilling the DEF tank. Ensure that the DEF tank cap area is free of debris before removing the cap. Seal containers of DEF between use to prevent contamination and evaporation.

Avoid splashing DEF and do not allow DEF to come into contact with skin, eyes, or mouth.

DEF is not harmful to handle, but DEF can be corrosive to materials such as steel, iron, zinc, nickel, copper,

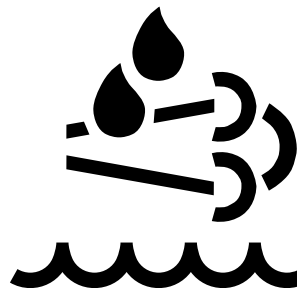

aluminum, and magnesium. Use suitable containers to transport and store DEF. Containers made of polyethylene, polypropylene, or stainless steel are recommended.

Avoid prolonged contact with skin. In case of accidental contact, wash skin immediately with soap and water.

Keep anything used to store or dispense DEF clean of dirt and dust. Wash and rinse containers or funnels thoroughly with distilled water to remove contaminants.

If an unapproved fluid, such as diesel fuel or coolant is added to the DEF tank, contact your John Deere dealer immediately to determine how to clean and purge the system.

If water has been added to the DEF tank, a tank cleaning is necessary. See Cleaning DEF Tank in this manual. After refilling the tank, check the DEF concentration. See Testing Diesel Exhaust Fluid (DEF).

The operator must maintain appropriate DEF levels at all times. Check the DEF level daily and refill the tank as needed. The filling port is identified by a blue colored cap embossed with the following DEF symbol.

DX,DEF,REFILL -19-15JUL20-1/1

TIS1731 —UN—23AUG13

Testing Diesel Exhaust Fluid (DEF)

IMPORTANT: Using DEF with the correct concentration is critical to engine and aftertreatment system performance. Extended storage and other conditions can adversely alter the DEF concentration.

If DEF quality is questionable, draw a sample out of the DEF tank or storage tank into a clear container. DEF must be crystal clear with a light ammonia smell. If DEF appears cloudy, has a colored tint, or has a profound ammonia smell, it is likely not within specification. DEF in this condition should not be used. Drain tank, flush with distilled water and refill with new or good DEF. After refilling the tank, check the DEF concentration.

If the DEF passes the visual and smell test, check the DEF concentration with a handheld refractometer calibrated to measure DEF.

DEF concentration should be checked when the engine has been stored for extended periods, or if there is

suspicion the engine or packaged DEF fluid has been contaminated with water.

Two approved tools are available through your John Deere dealer:

- JDG11594 Digital DEF Refractometer—A digital tool providing an easy to read concentration measurement
- JDG11684 DEF Refractometer—Low-cost alternative tool providing an analog reading

Follow instructions included with either tool to obtain the measurement.

The correct DEF concentration is 31.8—33.2% urea. If the DEF concentration is not within specification, drain the DEF tank, flush with distilled water and fill with new or good DEF. If packaged DEF is not within specification, dispose of DEF packages and replace with new or good DEF.

DX,DEF,TEST -19-13JUN13-1/1

Disposal of Diesel Exhaust Fluid (DEF)

Although there is little issue with minor spillage of DEF on the ground, large amounts of DEF should be contained. If large spills occur, contact local environmental authorities for assistance with clean-up.

If a substantial quantity of DEF is not within specification, contact the DEF supplier for assistance with disposal. Do

not dump substantial quantities of DEF onto the ground or send DEF to wastewater treatment facilities.

DX,DEF,DISPOSE -19-13JUN13-1/1

Diesel Fuel

Consult your local fuel distributor for properties of the diesel fuel available in your area.

In general, diesel fuels are blended to satisfy the low temperature requirements of the geographical area in which they are marketed.

Diesel fuels specified to EN 590 or ASTM D975 are recommended. Renewable diesel fuel produced by hydrotreating animal fats and vegetable oils is basically identical to petroleum diesel fuel. Renewable diesel that meets EN 590, ASTM D975, or EN 15940 is acceptable for use at all percentage mixture levels.

Required Fuel Properties

In all cases, the fuel shall meet the following properties:

Cetane number of 40 minimum. Cetane number greater than 47 is preferred, especially for temperatures below -20°C (-4°F) or elevations above 1675 m (5500 ft.).

Cloud Point should be below the expected lowest ambient temperature or **Cold Filter Plugging Point (CFPP)** should be a maximum 10°C (18°F) below the fuel cloud point.

Fuel lubricity should pass a maximum scar diameter of 0.52 mm as measured by ASTM D6079 or ISO 12156-1. A maximum scar diameter of 0.45 mm is preferred.

Diesel fuel quality and sulfur content must comply with all existing emissions regulations for the area in which the engine operates. DO NOT use diesel fuel with sulfur content greater than 10 000 mg/kg (10 000 ppm).

Materials such as copper, lead, zinc, tin, brass and bronze should be avoided in fuel handling, distribution and storage equipment as these metals can catalyze fuel oxidation reactions which can lead to fuel system deposits and plugged fuel filters.

E-Diesel fuel

DO NOT use E-Diesel (Diesel fuel and ethanol blend). Use of E-Diesel fuel in any John Deere machine may void the machine warranty.

CAUTION: Avoid severe injury or death due to the fire and explosion risk from using E-Diesel fuel.

¹See *DX, ENOIL12, OEM, DX, ENOIL12, T2, STD, or DX, ENOIL12, T2, EXT* for more information on Engine Oil and Filter Service Intervals.

Sulfur Content for Interim Tier 4, Final Tier 4, Stage III A and B, Stage IV, and Stage V Engines Above 560 kW

- Use ONLY diesel fuel with a maximum of 500 mg/kg (500 ppm) sulfur content.

Sulfur Content for Interim Tier 4, Final Tier 4, Stage III B, Stage IV Engines, and Stage V Engines

- Use ONLY ultra low sulfur diesel (ULSD) fuel with a maximum of 15 mg/kg (15 ppm) sulfur content.

Sulfur Content for Tier 3 and Stage III A Engines

- Use of diesel fuel with sulfur content less than 1000 mg/kg (1000 ppm) is RECOMMENDED.
- Use of diesel fuel with sulfur content 1000—2000 mg/kg (1000—2000 ppm) REDUCES the oil and filter change interval.
- BEFORE using diesel fuel with sulfur content greater than 2000 mg/kg (2000 ppm), contact your John Deere dealer.

Sulfur Content for Tier 2 and Stage II Engines

- Use of diesel fuel with sulfur content less than 2000 mg/kg (2000 ppm) is RECOMMENDED.
- Use of diesel fuel with sulfur content 2000—5000 mg/kg (2000—5000 ppm) REDUCES the oil and filter change interval.¹
- BEFORE using diesel fuel with sulfur content greater than 5000 mg/kg (5000 ppm), contact your John Deere dealer.

Sulfur Content for Other Engines

- Use of diesel fuel with sulfur content less than 5000 mg/kg (5000 ppm) is RECOMMENDED.
- Use of diesel fuel with sulfur content greater than 5000 mg/kg (5000 ppm) REDUCES the oil and filter change interval.

IMPORTANT: Do not mix used diesel engine oil or any other type of lubricating oil with diesel fuel.

Improper fuel additive usage may cause damage on fuel injection equipment of diesel engines.

Supplemental Diesel Fuel Additives

Diesel fuel can be the source of performance or other operational problems for many reasons. Some causes include poor lubricity, contaminants, low cetane number, and a variety of properties that cause fuel system deposits. These and others are referenced in other sections of this Operator's Manual.

To optimize engine performance and reliability, closely follow recommendations on fuel quality, storage, and handling, which are found elsewhere in this Operator's Manual.

To further aid in maintaining performance and reliability of the engine's fuel system, John Deere has developed a family of fuel additive products for most global markets. The primary products include Fuel-Protect Diesel Fuel Conditioner (full feature conditioner in winter and summer formulas) and Fuel-Protect Keep Clean (fuel injector deposit removal and prevention). Availability of these and other products varies by market. See your local John Deere dealer for availability and additional information about fuel additives that might be right for your needs.

DX,FUEL13 -19-07FEB14-1/1

Lubricity of Diesel Fuel

Most diesel fuels manufactured in the United States, Canada, and the European Union have adequate lubricity to ensure proper operation and durability of fuel injection system components. However, diesel fuels manufactured in some areas of the world may lack the necessary lubricity.

IMPORTANT: Make sure the diesel fuel used in your machine demonstrates good lubricity characteristics.

Fuel lubricity should pass a maximum scar diameter of 0.52 mm as measured by ASTM D6079 or ISO 12156-1. A maximum scar diameter of 0.45 mm is preferred.

If fuel of low or unknown lubricity is used, add John Deere Fuel-Protect Diesel Fuel Conditioner (or equivalent) at the specified concentration.

Lubricity of BioDiesel Fuel

Fuel lubricity can improve significantly with BioDiesel blends up to B20 (20% BioDiesel). Further increase in lubricity is limited for BioDiesel blends greater than B20.

DX,FUEL5 -19-07FEB14-1/1

Handling and Storing Diesel Fuel

CAUTION: Reduce the risk of fire. Handle fuel carefully. DO NOT fill the fuel tank when engine is running. DO NOT smoke while you fill the fuel tank or service the fuel system.

Fill the fuel tank at the end of each day's operation to prevent water condensation and freezing during cold weather.

Keep all storage tanks as full as practical to minimize condensation.

Ensure that all fuel tank caps and covers are installed properly to prevent moisture from entering. Monitor water content of the fuel regularly.

When using biodiesel fuel, the fuel filter may require more frequent replacement due to premature plugging.

Check engine oil level daily prior to starting engine. A rising oil level may indicate fuel dilution of the engine oil.

IMPORTANT: The fuel tank is vented through the filler cap. If a new filler cap is required, always replace it with an original vented cap.

When fuel is stored for an extended period or if there is a slow turnover of fuel, add a fuel conditioner to stabilize the fuel. Keeping the free water drained and treating the bulk fuel storage tank quarterly with a maintenance dose of a biocide will prevent microbial growth. Contact your fuel supplier or John Deere dealer for recommendations.

DX,FUEL4 -19-13JAN18-1/1

Biodiesel Fuel

Biodiesel fuel is comprised of monoalkyl esters of long chain fatty acids derived from vegetable oils or animal fats. Biodiesel blends are biodiesel mixed with petroleum diesel fuel on a volume basis.

Before using fuel containing biodiesel, review the Biodiesel Use Requirements and Recommendations in this Operator's Manual.

Environmental laws and regulations can encourage or prohibit the use of biofuels. Operators should consult with appropriate governmental authorities prior to using biofuels.

John Deere Stage V Engines Operating in the European Union

Where the engine is to be operated within the Union on diesel or non-road gas-oil, a fuel with a FAME content not greater than 8% volume/volume (B8) shall be used.

John Deere Engines with Exhaust Filter Except Stage V Engines Operating in the European Union

Biodiesel blends up to B20 can be used ONLY if the biodiesel (100% biodiesel or B100) meets ASTM D6751, EN 14214, or equivalent specification. Expect a 2% reduction in power and a 3% reduction in fuel economy when using B20.

Biodiesel concentrations above B20 can harm the engine's emission control systems and should not be used. Risks include, but are not limited to, more frequent stationary regeneration, soot accumulation, and increased intervals for ash removal.

John Deere Fuel conditioners or equivalent, which contain detergent and dispersant additives, are required when using biodiesel blends from B10 to B20, and are recommended when using lower biodiesel blends.

John Deere Engines Without Exhaust Filter

Biodiesel blends up to B20 can be used ONLY if the biodiesel (100% biodiesel or B100) meets ASTM D6751, EN 14214, or equivalent specification. Expect a 2% reduction in power and a 3% reduction in fuel economy when using B20.

These John Deere engines can operate on biodiesel blends above B20 (up to 100% biodiesel). Operate at levels above B20 ONLY if the biodiesel is permitted by law and meets the EN 14214 specification (primarily available in Europe). Engines operating on biodiesel blends above B20 might not fully comply with or be permitted by all applicable emissions regulations. Expect up to a 12% reduction in power and an 18% reduction in fuel economy when using 100% biodiesel.

John Deere fuel conditioners or equivalent, which contain detergent and dispersant additives, are required when using biodiesel blends from B10 to B100, and are recommended when using lower biodiesel blends.

Biodiesel Use Requirements and Recommendations

The petroleum diesel portion of all biodiesel blends must meet the requirements of ASTM D975 (US) or EN 590 (EU) commercial standard.

Biodiesel users in the U.S. are strongly encouraged to purchase biodiesel blends from a BQ-9000 Certified Marketer and sourced from a BQ-9000 Accredited Producer (as certified by the National Biodiesel Board). Certified Marketers and Accredited Producers can be found at the following website: <http://www.bq9000.org>.

Biodiesel contains residual ash. Ash levels exceeding the maximums allowed in either ASTM D6751 or EN14214 can result in more rapid ash loading and require more frequent cleaning of the Exhaust Filter (if present).

The fuel filter can require more frequent replacement when using biodiesel fuel, particularly if switching from diesel. Check engine oil level daily prior to starting engine. A rising oil level can indicate fuel dilution of the engine oil. Biodiesel blends up to B20 must be used within 90 days of the date of biodiesel manufacture. Biodiesel blends above B20 must be used within 45 days from the date of biodiesel manufacture.

When using biodiesel blends up to B20, the following must be considered:

- Cold-weather flow degradation
- Stability and storage issues (moisture absorption, microbial growth)
- Possible filter restriction and plugging (usually a problem when first switching to biodiesel on used engines)
- Possible fuel leakage through seals and hoses (primarily an issue with older engines)
- Possible reduction of service life of engine components

Request a certificate of analysis from your fuel distributor to ensure that the fuel is compliant with the specifications provided in this Operator's Manual.

Consult your John Deere dealer for John Deere fuel products to improve storage and performance with biodiesel fuels.

The following must also be considered if using biodiesel blends above B20:

- Possible coking or blocked injector nozzles, resulting in power loss and engine misfire if John Deere fuel additives and conditioners or equivalent containing detergent/dispersants are not used
- Possible crankcase oil dilution (requiring more frequent oil changes)
- Possible lacquering or seizure of internal components
- Possible formation of sludge and sediments
- Possible thermal oxidation of fuel at elevated temperatures

Continued on next page

DX,FUEL7 -19-13JAN18-1/2

- Possible compatibility issues with other materials (including copper, lead, zinc, tin, brass, and bronze) used in fuel handling, distribution, and storage equipment
- Possible reduction in water separator efficiency
- Possible damage to paint if exposed to biodiesel
- Possible corrosion of fuel injection equipment
- Possible elastomeric seal and gasket material degradation (primarily an issue with older engines)
- Possible high acid levels within fuel system

- Because biodiesel blends above B20 contain more ash, using blends above B20 can result in more rapid ash loading and require more frequent cleaning of the Exhaust Filter (if present)

IMPORTANT: Raw pressed vegetable oils are NOT acceptable for use as fuel in any concentration in John Deere engines. Their use could cause engine failure.

DX,FUEL7 -19-13JAN18-2/2

Testing Diesel Fuel

A fuel analysis program can help to monitor the quality of diesel fuel. The fuel analysis can provide critical data such as calculated cetane index, fuel type, sulfur content, water content, appearance, suitability for cold weather

operations, bacteria, cloud point, acid number, particulate contamination, and whether the fuel meets ASTM D975 or equivalent specification.

Contact your John Deere dealer for more information on diesel fuel analysis.

DX,FUEL6 -19-13JAN18-1/1

Fuel Filters

The importance of fuel filtration cannot be overemphasized with modern fuel systems. The combination of increasingly restrictive emission regulations and more efficient engines requires fuel system to operate at much higher pressures. Higher pressures can only be achieved using fuel injection components with very close tolerances. These close

manufacturing tolerances have significantly reduced capacities for debris and water.

John Deere brand fuel filters have been designed and produced specifically for John Deere engines.

To protect the engine from debris and water, always change engine fuel filters as specified in this manual.

DX,FILT2 -19-14APR11-1/1

Minimizing the Effect of Cold Weather on Diesel Engines

John Deere diesel engines are designed to operate effectively in cold weather.

However, for effective starting and cold-weather operation, a little extra care is necessary. The following information outlines steps that can minimize the effect that cold weather may have on starting and operation of your engine. See your John Deere dealer for additional information and local availability of cold-weather aids.

Use Winter Grade Fuel

When temperatures fall below 0°C (32°F), winter grade fuel (No. 1-D in North America) is best suited for cold-weather operation. Winter grade fuel has a lower cloud point and a lower pour point.

Cloud point is the temperature at which wax begins to form in the fuel. This wax causes fuel filters to plug. **Pour point** is the lowest temperature at which movement of the fuel is observed.

NOTE: On average, winter grade diesel fuel has a lower Btu (heat content) rating. Using winter grade fuel may reduce power and fuel efficiency, but should not cause any other engine performance effects. Check the grade of fuel being used before troubleshooting for low-power complaints in cold-weather operation.

Air Intake Heater

An air intake heater is an available option for some engines to aid cold weather starting.

Ether

An ether port on the intake is available to aid cold weather starting.

CAUTION: Ether is highly flammable. Do not use ether when starting an engine equipped with glow plugs or an air intake heater.

Coolant Heater

An engine block heater (coolant heater) is an available option to aid cold weather starting.

Seasonal Viscosity Oil and Proper Coolant Concentration

Use seasonal grade viscosity engine oil based on the expected air temperature range between oil changes and a proper concentration of low silicate antifreeze as recommended. (See DIESEL ENGINE OIL and ENGINE COOLANT requirements in this section.)

Diesel Fuel Cold Flow Additive

Use John Deere Fuel-Protect Diesel Fuel Conditioner (winter formula), which contains anti-gel chemistry, or equivalent fuel conditioner to treat non-winter grade fuel (No. 2-D in North America) during the cold-weather season. This generally extends operability to about 10°C (18°F) below the fuel cloud point. For operability at even lower temperatures, use winter grade fuel.

IMPORTANT: Treat fuel when outside temperature drops below 0°C (32°F). For best results, use with untreated fuel. Follow all recommended instructions on label.

Biodiesel

When operating with biodiesel blends, wax formation can occur at warmer temperatures. Begin using John Deere Fuel-Protect Diesel Fuel Conditioner (winter formula) or equivalent at 5°C (41°F) to treat biodiesel fuels during the cold-weather season. Use B5 or lower blends at temperatures below 0°C (32°F). Use only winter grade petroleum diesel fuel at temperatures below -10°C (14°F).

Winterfronts

Use of fabric, cardboard, or solid winterfronts is not recommended with any John Deere engine. Their use can result in excessive engine coolant, oil, and charge air temperatures. This can lead to reduced engine life, loss of power and poor fuel economy. Winterfronts may also put abnormal stress on fan and fan drive components potentially causing premature failures.

If winterfronts are used, they should never totally close off the grill frontal area. Approximately 25% area in the center of the grill should remain open at all times. At no time should the air blockage device be applied directly to the radiator core.

Radiator Shutters

If equipped with a thermostatically controlled radiator shutter system, this system should be regulated in such a way that the shutters are completely open by the time the coolant reaches 93°C (200°F) to prevent excessive intake manifold temperatures. Manually controlled systems are not recommended.

If air-to-air aftercooling is used, the shutters must be completely open by the time the intake manifold air temperature reaches the maximum allowable temperature out of the charge air cooler.

For more information, see your John Deere dealer.

DX,FUEL10 -19-13JAN18-1/1

John Deere Break-In Plus™ Engine Oil — Interim Tier 4, Final Tier 4, Stage IIIB, Stage IV, and Stage V

New engines are filled at the factory with John Deere Break-In Plus™ Engine Oil. During the break-in period, add John Deere Break-In Plus™ Engine Oil, as needed to maintain the specified oil level.

Operate the engine under various conditions, particularly heavy loads with minimal idling, to help seat engine components properly.

During the initial operation of a new or rebuilt engine, change the oil and filter between a minimum of 100 hours and maximum equal to the interval specified for John Deere Plus-50™ II oil.

After engine overhaul, fill the engine with John Deere Break-In Plus™ Engine Oil.

If John Deere Break-In Plus™ Engine Oil is not available, use an SAE 10W-30 viscosity grade diesel engine oil meeting one of the following:

*Break-In Plus is a trademark of Deere & Company
Plus-50 is a trademark of Deere & Company.*

- API Service Category CK-4
- API Service Category CJ-4
- ACEA Oil Sequence E9
- ACEA Oil Sequence E6

If one of these oils is used during the initial operation of a new or rebuilt engine, change the oil and filter between a minimum of 100 hours and a maximum of 250 hours.

IMPORTANT: Do not use any other engine oils during the initial break-in of a new or rebuilt engine.

John Deere Break-In Plus™ Engine Oil can be used for all John Deere diesel engines at all emission certification levels.

After the break-in period, use John Deere Plus-50™ II or other diesel engine oil as recommended in this manual.

DX,ENOIL16 -19-13JAN18-1/1

Diesel Engine Oil — Interim Tier 4, Final Tier 4, Stage IIIB, Stage IV, and Stage V

Failure to follow applicable oil standards and drain intervals can result in severe engine damage that might not be covered under warranty. Warranties, including the emissions warranty, are not conditioned on the use of John Deere oils, parts, or service.

Use oil viscosity based on the expected air temperature range during the period between oil changes.

John Deere Plus-50™ II is the recommended engine oil.

Extended service intervals may apply when John Deere Plus-50™ II engine oil is used. Refer to the engine oil drain interval table and consult your John Deere dealer for more information.

If John Deere Plus-50™ II engine oil is not available, engine oil meeting one or more of the following may be used:

- API Service Category CK-4
- API Service Category CJ-4
- ACEA Oil Sequence E9
- ACEA Oil Sequence E6

DO NOT use engine oil containing more than 1.0% sulfated ash, 0.12% phosphorus, or 0.4% sulfur.

Multi-viscosity diesel engine oils are preferred.

Diesel fuel quality and fuel sulfur content must comply with all existing emissions regulations for the area in which the engine operates.

Plus-50 is a trademark of Deere & Company

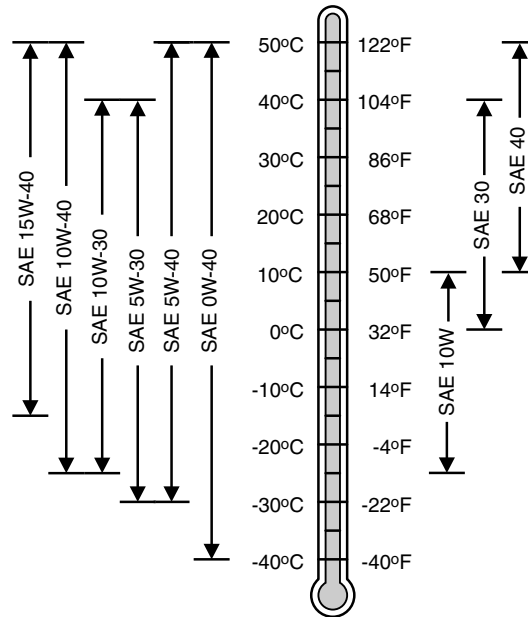

Oil Viscosities for Air Temperature Ranges

IMPORTANT: Use only ultra low sulfur diesel (ULSD) fuel with a maximum sulfur content of 15 mg/kg (15 ppm).

TS1743 —UN—25APR19

DX,ENOIL14 -19-23APR19-1/1

Diesel Engine Oil and Filter Service Intervals — Interim Tier 4, Final Tier 4, Stage IIIB, Stage IV, and Stage V— OEM Applications

Failure to follow applicable oil standards and drain intervals can result in severe engine damage that might not be covered under warranty. Warranties, including the emissions warranty, are not conditioned on the use of John Deere oils, parts, or service.

Recommended oil and filter service intervals are based on a combination of oil pan capacity, type of engine oil and filter used, and sulfur content of the diesel fuel. Actual service intervals also depend on operation and maintenance practices.

Approved Oil Types

- John Deere Plus-50™ II
- “Other Oils” include API CK-4, API CJ-4, ACEA E9, and ACEA E6.

Use oil analysis to evaluate the condition of the oil and to aid in selection of the proper oil and filter service interval. Contact your John Deere dealer or other qualified service provider for more information on engine oil analysis.

Change the oil and oil filter at least once every 12 months even if the hours of operation are fewer than the otherwise recommended service interval.

Diesel fuel sulfur content affects engine oil and filter service intervals. Higher fuel sulfur levels reduce oil and filter service intervals.

Use of diesel fuel with sulfur content less than 15 mg/kg (15 ppm) is **REQUIRED**.

Engine operation at high altitude decreases oil change intervals. See Diesel Engine Oil Service Interval for Operation at High Altitude for additional information.

Plus-50 is a trademark of Deere & Company

NOTE: The 500-hour extended oil and filter change interval is only allowed if all of the following conditions are met:

- Engine equipped with an extended drain interval oil pan
- Use of diesel fuel with sulfur content less than 15 mg/kg (15 ppm)
- Use of John Deere Plus-50™ II oil
- Use of an approved John Deere oil filter

IMPORTANT: To avoid engine damage:

- Reduce oil and filter service intervals by **50%** when using biodiesel blends greater than B20. Oil analysis may allow longer service interval
- Use only approved oil types

Engine Oil and Filter Service Intervals		
	Oil Pan Size (L/kW)	
	Greater than or equal to 0.10	Greater than or equal to 0.12
John Deere Plus-50™ II	375 hours	500 hours
Other Oils	250 hours	250 hours

Oil analysis may extend the service interval of “Other Oils” to a maximum not to exceed the interval of Plus-50™ II oils. Oil analysis means taking a series of oil samples at 50-hour increments beyond the normal service interval until either the data indicates the end of useful oil life or the maximum service interval of John Deere Plus-50 II oils is reached.

DX,ENOIL15,IT4,OEM -19-13JAN18-1/1

Diesel Engine Oil and Filter Service Intervals

Power Rating	Fuel Sulfur Content	Oil Pan Option Codes							
		1903 19BB		19AE 19BC		1923 19BA		1976 19AZ 19GK	
kW (hp)		Other Oils	John Deere Plus-50 II	Other Oils	John Deere Plus-50 II	Other Oils	John Deere Plus-50 II	Other Oils	John Deere Plus-50 II
63 (85)	≤15 ppm	250 hours	500 hours	250 hours	500 hours	250 hours	500 hours	250 hours	500 hours
74 (100)	≤15 ppm	250 hours	500 hours	250 hours	500 hours	250 hours	500 hours	250 hours	500 hours
86 (115)	≤15 ppm	250 hours	500 hours	250 hours	500 hours	250 hours	500 hours	250 hours	500 hours
93 (125)	≤15 ppm	250 hours	500 hours	250 hours	500 hours	250 hours	500 hours	250 hours	500 hours
100 (135)	≤15 ppm	250 hours	500 hours	250 hours	500 hours	250 hours	500 hours	250 hours	500 hours
104 (140)	≤15 ppm	250 hours	500 hours	250 hours	500 hours	250 hours	500 hours	250 hours	500 hours
129 (173)	≤15 ppm	250 hours	500 hours	250 hours	500 hours	250 hours	500 hours	250 hours	500 hours

ZE59858,0000008 -19-26SEP19-1/1

Mixing of Lubricants

In general, avoid mixing different brands or types of oil. Oil manufacturers blend additives in their oils to meet certain specifications and performance requirements.

Mixing different oils can interfere with the proper functioning of these additives and degrade lubricant performance.

Consult your John Deere dealer to obtain specific information and recommendations.

DX,LUBMIX -19-18MAR96-1/1

Alternative and Synthetic Lubricants

Conditions in certain geographical areas may require lubricant recommendations different from those printed in this manual.

Some John Deere brand coolants and lubricants may not be available in your location.

Consult your John Deere dealer to obtain information and recommendations.

Synthetic lubricants may be used if they meet the performance requirements as shown in this manual.

The temperature limits and service intervals shown in this manual apply to John Deere branded fluids or fluids that have been tested and/or approved for use in John Deere equipment.

Re-refined base stock products may be used if the finished lubricant meets the performance requirements.

DX,ALTER -19-13JAN18-1/1

Lubricant Storage

Your equipment can operate at top efficiency only when clean lubricants are used.

Use clean containers to handle all lubricants.

Store lubricants and containers in an area protected from dust, moisture, and other contamination. Store containers on their side to avoid water and dirt accumulation.

Make certain that all containers are properly marked to identify their contents.

Properly dispose of all old containers and any residual lubricant they may contain.

DX,LUBST -19-11APR11-1/1

Oil Filters

Filtration of oils is critically important for proper operation and lubrication. John Deere brand oil filters have been designed and produced specifically for John Deere applications.

John Deere filters adhere to engineering specifications for quality of the filter media, filter efficiency rating, strength

of the bond between the filter media and the element end cap, fatigue life of the canister (if applicable), and pressure capability of the filter seal. Non-John Deere branded oil filters might not meet these key John Deere specifications.

Always change oil filters regularly as specified in this manual.

DX,FILT1 -19-11APR11-1/1

Diesel Engine Coolant (engine with wet sleeve cylinder liners)

Failure to follow applicable coolant standards and drain intervals can result in severe engine damage that may not be covered under warranty. Warranties, including the emissions warranty, are not conditioned on the use of John Deere coolants, parts, or service.

Preferred Coolants

The following pre-mix engine coolants are preferred:

- John Deere COOL-GARD™ II
- John Deere COOL-GARD II PG

COOL-GARD II pre-mix coolant is available in several concentrations with different freeze protection limits as shown in the following table.

COOL-GARD II Pre-Mix	Freeze Protection Limit
COOL-GARD II 20/80	-9°C (16°F)
COOL-GARD II 30/70	-16°C (3°F)
COOL-GARD II 50/50	-37°C (-34°F)
COOL-GARD II 55/45	-45°C (-49°F)
COOL-GARD II PG 60/40	-49°C (-56°F)
COOL-GARD II 60/40	-52°C (-62°F)

Not all COOL-GARD II pre-mix products are available in all countries.

Use COOL-GARD II PG when a non-toxic coolant formulation is required.

Additional Recommended Coolants

The following engine coolant is also recommended:

- John Deere COOL-GARD II Concentrate in a 40—60% mixture of concentrate with quality water.

IMPORTANT: When mixing coolant concentrate with water, do not use less than 40% or greater than 60% concentration of coolant. Less than 40% gives inadequate additives for corrosion protection. Greater than 60% can result in coolant gelation and cooling system problems.

Other Coolants

Other ethylene glycol or propylene glycol base coolants may be used if they meet the following specification:

COOL-GARD is a trademark of Deere & Company

¹Coolant analysis may extend the service interval of other "Coolants" to a maximum not to exceed the interval of Cool-Gard II coolants. Coolant analysis means taking a series of coolant samples at 1000 hour increments beyond the normal service interval until either the data indicate the end of useful coolant life or the maximum service interval of Cool-Gard II is reached.

- Pre-mix coolant meeting ASTM D6210 requirements
- Is formulated with a 2-ethylhexanoic acid (2-EHA) free additive package
- Coolant concentrate meeting ASTM D6210 requirements in a 40—60% mixture of concentrate with quality water

If coolant meeting one of these specifications is unavailable, use a coolant concentrate or pre-mix coolant that has a minimum of the following chemical and physical properties:

- Provides cylinder liner cavitation protection according to either the John Deere Cavitation Test Method or a fleet study run at or above 60% load capacity
- Is formulated with a nitrite-free additive package
- Is formulated with a 2-ethylhexanoic acid (2-EHA) free additive package
- Protects the cooling system metals (cast iron, aluminum alloys, and copper alloys such as brass) from corrosion

Water Quality

Water quality is important to the performance of the cooling system. Deionized or demineralized water is recommended for mixing with ethylene glycol and propylene glycol base engine coolant concentrate.

Coolant Drain Intervals

Drain and flush the cooling system and refill with fresh coolant at the indicated interval, which varies with the coolant used.

When COOL-GARD II or COOL-GARD II PG is used, the drain interval is 6 years or 6000 hours of operation.

If a coolant other than COOL-GARD II or COOL-GARD II PG is used, reduce the drain interval to 2 years or 2000 hours of operation.¹

IMPORTANT: Do not use cooling system sealing additives or antifreeze that contains sealing additives.

Do not mix ethylene glycol and propylene glycol base coolants.

Do not use coolants that contain nitrites.

Water Quality for Mixing with Coolant Concentrate

Engine coolants are a combination of three chemical components: ethylene glycol (EG) or propylene glycol (PG) antifreeze, inhibiting coolant additives, and quality water.

Water quality is important to the performance of the cooling system. Deionized or demineralized water is recommended for mixing with ethylene glycol and propylene glycol base engine coolant concentrate.

All water used in the cooling system should meet the following minimum specifications for quality:

Chlorides	<40 mg/L
Sulfates	<100 mg/L
Total solids	<340 mg/L
Total dissolved hardness	<170 mg/L
pH	5.5—9.0

IMPORTANT: Do not use bottled drinking water because it often contains higher concentrations of total dissolved solids.

Freeze Protection

The relative concentrations of glycol and water in the engine coolant determine its freeze protection limit.

Ethylene Glycol	Freeze Protection Limit
40%	-24°C (-12°F)
50%	-37°C (-34°F)
60%	-52°C (-62°F)
Propylene Glycol	Freeze Protection Limit
40%	-21°C (-6°F)
50%	-33°C (-27°F)
60%	-49°C (-56°F)

DO NOT use a coolant-water mixture greater than 60% ethylene glycol or 60% propylene glycol.

DX,COOL19 -19-13JAN18-1/1

Operating in Warm Temperature Climates

John Deere engines are designed to operate using recommended engine coolants.

Always use a recommended engine coolant, even when operating in geographical areas where freeze protection is not required.

IMPORTANT: Water may be used as coolant in emergency situations only.

Foaming, hot surface aluminum and iron corrosion, scaling, and cavitation occur when water is used as the coolant, even when coolant conditioners are added.

Drain cooling system and refill with recommended engine coolant as soon as possible.

DX,COOL6 -19-17FEB20-1/1

Testing Coolant Freeze Point

The use of a handheld coolant refractometer is the quickest, easiest, and most accurate method to determine coolant freeze point. This method is more accurate than a test strip or a float-type hydrometer which can produce poor results.

A coolant refractometer is available through your John Deere dealer under the SERVICEGARD™ tool program. Part number 75240 provides an economical solution to accurate freeze point determination in the field.

To use this tool:

1. Allow cooling system to cool to ambient temperatures.
2. Open radiator cap to expose coolant.
3. With the included dropper, collect a small coolant sample.
4. Open the lid of the refractometer, place one drop of coolant on the window and close the lid.
5. Look through the eyepiece and focus as necessary.
6. Record the listed freeze point for the type of coolant (ethylene glycol coolant or propylene glycol) being tested.



SERVICEGARD™ Part Number 75240

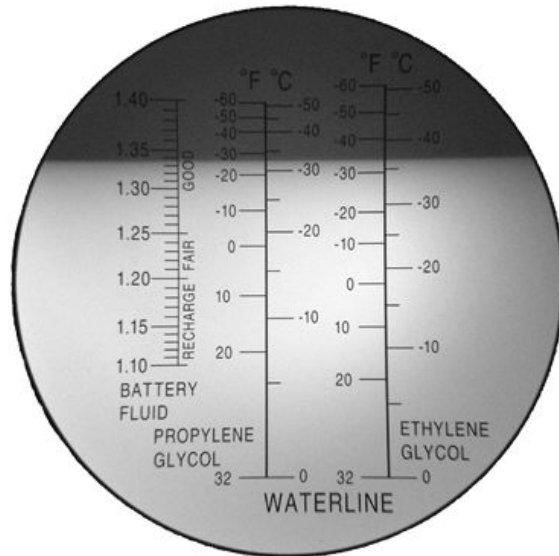

Image with a Drop of 50/50 Coolant Placed on the Refractometer Window

SERVICEGARD is a trademark of Deere & Company

DX.COOL.TEST -19-13JUN13-1/1

TS1733 —UN—04SEP13

TS1733 —UN—04SEP13

Disposing of Coolant

Improperly disposing of engine coolant can threaten the environment and ecology.

Use leakproof containers when draining fluids. Do not use food or beverage containers that may mislead someone into drinking from them.

Do not pour waste onto the ground, down a drain, or into any water source.

Inquire on the proper way to recycle or dispose of waste from your local environmental or recycling center, or from your John Deere engine distributor or servicing dealer.

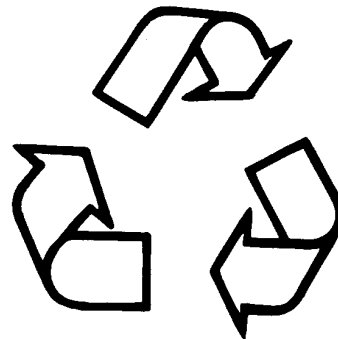

Recycle Waste

RG.RG34710,7543 -19-26APR18-1/1

TS1133 —UN—15APR13

Instrument Panels

PV101 Instrument Panels

Interim tier 4 / Stage III B John Deere PowerTech OEM Engines have an electronic control system, which has the following controls and gauges as shown. The following information applies only to those controls and gauges supplied by John Deere. Refer to your engine application manual for specific guidelines if John Deere-sourced controls and instrumentation are not used.

NOTE: This manual only covers operation of engine with a John Deere control system.

Following is a brief description of the available optional electronic controls and gauges found on John Deere provided instrument panels. Refer to manufacturer's literature for information on controls not provided by Deere.

A—Diagnostic Gauge/Hour Meter

The diagnostic gauge (A) displays diagnostic trouble codes (DTCs) as they are accessed. Other information on the engine can be accessed using the touch keys (N, O, and P). The hour meter shows the operating hours of the engine and should be used as a guide for scheduling periodic maintenance. If the diagnostic gauge receives a trouble code from an engine control unit, the current display will switch to a warning or shutdown (depending on the severity of the code) screen that will display the trouble code number, the description of the code and the corrective action needed.

B—Tachometer

The tachometer (B) indicates engine speed in hundreds of revolutions per minute (rpm). **C—Voltmeter (Optional)**

The voltmeter (C) indicates system battery voltage. The amber "Warning" light (Q) will illuminate when battery voltage is too low for proper operation of the fuel injection system.

D—Audible Alarm (Optional)

The audible alarm (D) will sound whenever low oil pressure, high coolant temperature, or water-in-fuel conditions exist. This includes all signals that light up the amber "WARNING" indicator (intermittent alarm) or the red "STOP ENGINE" indicator (steady alarm).

E—Audible Alarm Override Button

The optional audible alarm has an override button (E) that silences the audible alarm for approximately two minutes when pressed.

F—Key Start Switch

The three-position key start switch (F) controls the engine electrical system. From the "OFF" position when the key switch is turned clockwise to "START", the engine will crank. When the engine starts, the key is released and returns to the "ON" (RUN) position.

G—Override Shutdown Rocker Switch

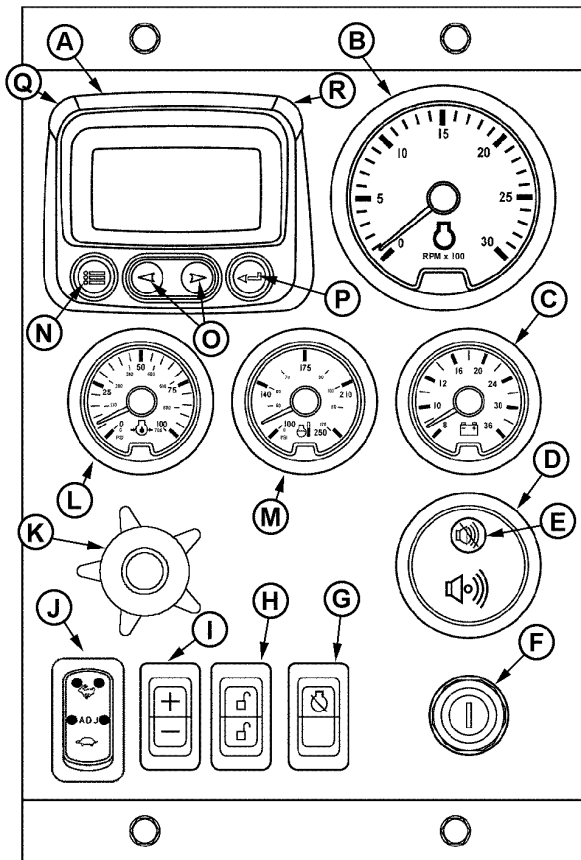

Full-Featured Instrument Panel

- | | |
|--|--|
| A—Diagnostic Gauge/Hour Meter | J—High-Low Speed Select Rocker Switch |
| B—Tachometer | K—Analog Throttle Control (Optional) |
| C—Voltmeter (Optional) | L—Oil Pressure Gauge |
| D—Audible Alarm (Optional) | M—Coolant Temperature Gauge |
| E—Audible Alarm Override Button | N—Menu Key |
| F—Key Switch | O—Arrow Key (2 used) |
| G—Override Shutdown Rocker Switch | P—Enter Key |
| H—Bump Enable Rocker Switch | Q—Amber "WARNING" Indicator Light |
| I—Speed Select Rocker Switch | R—Red "STOP ENGINE" Indicator Light |

Switch will be present, but may not be active, depending on engine control unit (ECU) options originally selected. If switch is active, pressing the upper half of the override shutdown switch (G) will override an engine shutdown signal. The switch must be pressed within 30 seconds to prevent undesired shutdown of engine. Pressing this switch will override the ECU engine shutdown command for 30 seconds at a time to move vehicle to a safe location.

H—Bump Speed Enable Rocker Switch

Continued on next page

JR74534.00002C7 -19-16AUG21-1/2

This is a three-position switch (H) with the center position as “OFF” (locked). With this switch in the “OFF” position, the speed select switch (I) is also locked, to prevent accidental changes in operating speed. Pressing upper or lower half of switch (H) will unlock or enable the bump speed switch to take effect using speed select switch (I).

I—Speed Select Rocker Switch

The speed select switch (I) is used to bump engine speed up (+) or down (-) in small increments during operation. This switch must be used with the bump speed enable switch (H) in the unlocked position (top or bottom half of button depressed).

J—High-Low Speed Select Rocker Switch

The high-low speed select switch (J) is used to set the engine operating speeds at slow (turtle) or fast (rabbit). Factory preset idle speeds can also be adjusted using bump speed enable switch (H) with speed select switch (I).

The basic instrument panel will have the high-low speed select switch only. Press and hold up (+) or down (-) to adjust engine speed as desired. The engine speed selected will not be held in the memory. To adjust engine speeds, See Changing Engine Speeds in Section 20.

How To Select Preset Operating Speeds (Bump Speeds)

First select “Turtle” (slow) or “Adj” by pressing speed select switch (J) to “Turtle” (slow) or “Adj”(center). Then you can press either the upper or lower portion of the bump speed enable switch (H) to unlock the setting. The bump speed enable must be held down as the speed select switch (J) is used to change the setting by pressing (+) to increase speed or (-) to decrease speed.

Once the slow idle speed has been set, the bump speed enable **switch must be pressed and released three times within two seconds to commit the new operating speed to memory.** If not done, the engine's new speed will only be effective until the key switch is shut off. Then the speed will revert back to the previous setting.

The fast idle speed is not adjustable. It will always go back to the factory preset fast idle speed.

K—Analog Throttle Control (Optional)

The throttle control (K) is used to control engine speed. This control is available only on engines with analog throttle.

L—Engine Oil Pressure Gauge

The oil pressure gauge (L) indicates engine oil pressure. An audible alarm (D) warns the operator if engine oil pressure falls below a safe operating pressure.

M—Engine Coolant Temperature Gauge

The engine coolant temperature gauge (M) indicates engine coolant temperature. An audible alarm (D) warns the operator if coolant temperature rises above the preset safe operating temperature.

N—Menu Key

The menu key is pressed to either enter or exit the menu screens on the diagnostic gauge (A).

O—Arrow Keys

Use the arrow keys (O) to change the display on the window of the diagnostic gauge (A) and to access engine performance data.

Pressing the left arrow to scroll to the left or upward or the right arrow to scroll to the right or downward. This will allow you to view various engine parameters and any diagnostic trouble codes that occur.

Refer to the following procedure for accessing engine information on the diagnostic gauge using the touch keys.

P—Enter Key

The enter key (P) is pressed to select the parameter that is highlighted on the screen.

Q—Amber “WARNING” Indicator Light

When light is illuminated, an abnormal condition exists. It is not necessary to shut down the engine immediately, but the problem should be corrected as soon as possible.

R—Red “STOP ENGINE” Indicator Light

When light is illuminated, stop engine immediately or as soon as safely possible to prevent engine damage. Correct problem before restarting.

JR74534,00002C7 -19-16AUG21-2/2

PV101 Diagnostic Gauge — Using

The diagnostic gauge (A) allows the operator to monitor engine functions, view diagnostic trouble codes (DTCs), and perform preliminary diagnostics. The gauge is linked to the electronic control system and sensors.

The menu key (B) allows the operator to access the main menu of the diagnostic gauge. For more information see PV101 Diagnostic Gauge — Main Menu in Section 15. This key also allows the operator to cancel an option and go back to the previous menu or home menu.

The arrow keys (C) allows the operator to scroll between menu items. The arrow keys automatically change from up and down, to left and right depending on the menu item to be selected.

The enter key (D) allows the operator to access menu items selected by the arrow keys (C) and confirm changes made by the operator.

The red “STOP ENGINE” indicator light (E) allows the operator to visually see when a condition exists which requires immediate operator action and service.

The amber “WARNING” indicator light (F) allows the operator to visually see when a condition exists which requires operator action.

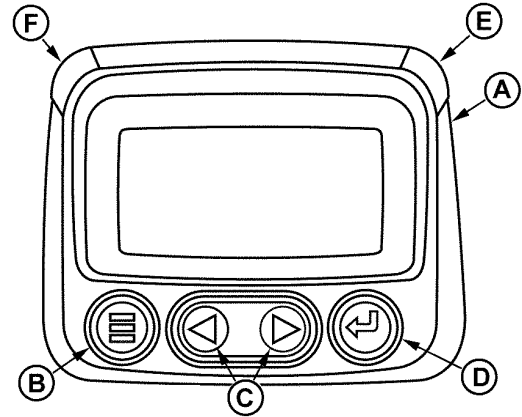

Diagnostic Gauge

A—Diagnostic Gauge
B—Menu Key
C—Arrow Keys

D—Enter Key
E—Red “STOP ENGINE”
Indicator Light
F—Amber “WARNING”
Indicator Light

RG13132 —UN—09SEP03

BL90236,000002A -19-16AUG21-1/1

PV101 Diagnostic Gauge — Main Menu

NOTE: The engine does not need to be running to navigate the diagnostic gauge screens.

The main menu is the starting point in accessing engine information and configuring the diagnostic gauge. Press the menu key (B) to access the main menu.

Use the arrow keys (C) and enter key (D) to view menu items displayed:

- Go to 4-up display
- Exhaust filter
- Engine speed control
- Languages
- Stored codes
- Engine configuration
- Setup 1-up display
- Setup 4-up display
- Select units
- Adjust backlight
- Adjust contrast
- Utilities

Listed are examples of features available in main menu items.

In Utilities:

- Gauge data
- Remove all gauges
- Software version
- Modbus setup
- Fault conversion

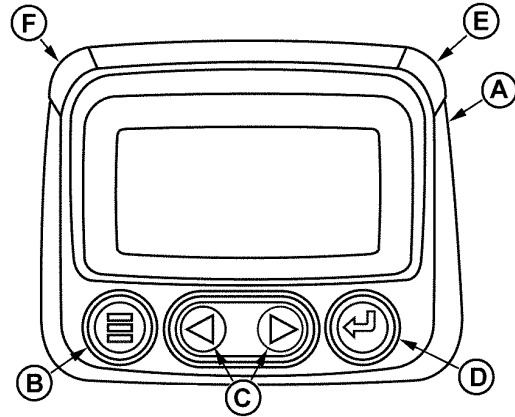

Diagnostic Gauge

- A—Diagnostic Gauge
- B—Menu Key
- C—Arrow Key (2 used)

- D—Enter Key
- E—Red “STOP ENGINE” Indicator Light
- F—Amber “WARNING” Indicator Light

- Select engine ECU
- Clear machine hours
- Performance data
- Interactive tests
- Reset trip
- Set function instance
- ECU software update

RG13132 —UN—09SEP03

JR74534,00002C8 -19-16AUG21-1/1

PV101 Diagnostic Gauge — Essential Menus

Automatic Exhaust Filter Cleaning

To enable auto exhaust filter cleaning mode:

1. Press menu key on diagnostic gauge
2. Press arrow keys to scroll up or down to EXHAUST FILTER
3. Press select key
4. Press arrow keys to scroll up or down to AUTO EXH FLT CLEAN
5. Press select key to enable auto exhaust filter cleaning

Manual/Parked Exhaust Filter Cleaning

To request a manual/parked exhaust filter cleaning:

1. Reduce engine speed to slow idle
2. Press menu key
3. Press arrow keys to scroll up or down to EXHAUST FILTER
4. Press select key
5. Press arrow keys to scroll up or down to REQUEST EXH FLT CLEAN
6. Press select key to request a manual/parked exhaust filter cleaning
7. Follow directions on display and ensure all conditions are met
8. Press select key to CONFIRM all conditions are met

Disable Exhaust Filter Cleaning

To disable the auto exhaust filter cleaning mode:

1. Press menu key on diagnostic gauge
2. Press arrow keys to scroll up or down to EXHAUST FILTER
3. Press select key
4. Press arrow keys to scroll up or down to DISABLE EXH FLT CLEAN
5. Press select key to disable exhaust filter cleaning

Fault Codes — Active

To view active fault code information:

1. Press menu key on diagnostic gauge
2. Press arrow keys to scroll up or down to FAULTS
3. Press select key
4. Press arrow keys to scroll up or down to ACTIVE FAULTS
5. Press select key
6. Press arrow keys to scroll through available faults

Fault Codes — Stored

To view stored fault code information:

1. Press menu key on diagnostic gauge
2. Press arrow keys to scroll up or down to FAULTS
3. Press select key
4. Press arrow keys to scroll up or down to STORED FAULTS
5. Press select key
6. Press arrow keys to scroll up or down to VIEW
7. Press select key
8. Press arrow keys to scroll through available faults

BL90236,0000025 -19-02JUN16-1/1

DG14 Diagnostic Gauge — Using

The diagnostic gauge (A) allows the operator to monitor engine functions, view diagnostic trouble codes (DTCs), and perform preliminary diagnostics. The gauge is linked to the electronic control system and sensors.

The home menu key (B) allows the operator to access the main menu of the diagnostic gauge. For more information, see DG14 Diagnostic Gauge — Main Menu in Section 15. This key also allows the operator to cancel an option and go back to the previous menu or home menu.

The arrow keys (C) allows the operator to scroll between menu items. The arrow keys automatically change from up and down, to left and right depending on the menu item to be selected.

The check mark select key (D) allows the operator to access menu items selected by the arrow keys (C) and confirm changes made by the operator.

The indicator lights (E) allows the operator to visually see the presence of an active DTC.

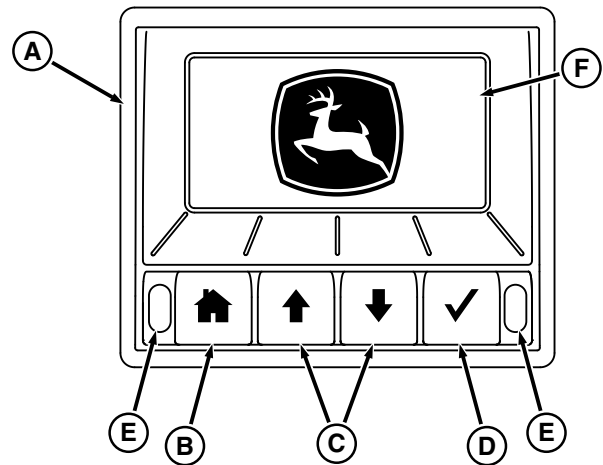

DG14 Diagnostic Gauge

A—Diagnostic Gauge
B—Home Menu Key
C—Arrow Key (2 used)

D—Check Mark Select Key
E—Indicator Light (2 used)
F—Display

RG27904 —UN—25FEB16

BL90236,0000028 -19-19AUG21-1/1

DG14 Diagnostic Gauge — Main Menu

NOTE: The engine does not need to be running to navigate the diagnostic gauge menu screens.

The main menu is the starting point in accessing engine information and configuring the diagnostic gauge. Press the home menu key (B) to access the main menu.

Use the arrow keys (C) and select key (D) to view menu items displayed:

- Function
- Display
- Utility
- Setup

Listed are examples of features available in main menu items.

In Function:

- View DTC
- Reset trip (FT4 Only)
- Exhaust regeneration (IT4 & FT4 Only)
- ECU software updates

In Display:

- Adjust backlight
- Adjust indicator brightness
- Display option setup

In Utility:

- Full parameter list
- Software data
- Select units
- Select language

In Setup:

- Select analog input
- Select digital input
- Select digital output

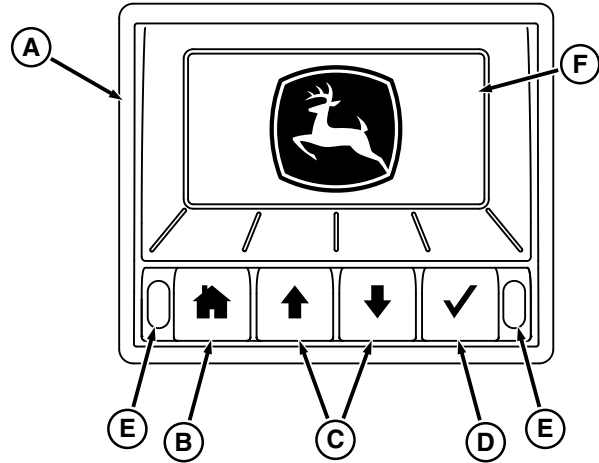

Diagnostic Gauge

A—Diagnostic Gauge
B—Home Menu Key
C—Arrow Key (2 used)

D—Check Mark Select Key
E—Indicator Light (2 used)
F—Display

- Alarm functionality
- Add J1939 gauge
- Set RS485 messaging
- Set engine source address
- Set function instance
- Harness diagnostics
- TSC control (password protected)

Key Code for Password Protected Screens

Numeric values are assigned to keys on diagnostic gauge as identified below:

- 1 — Home Menu Key
- 2 — Up Arrow Key
- 3 — Down Arrow Key
- 4 — Check Mark Select Key

RG27904—UN—25FEB16

BL90236,0000029 -19-19AUG21-1/1

DG14 Diagnostic Gauge — Essential Menus

Automatic Exhaust Filter Cleaning

To enable auto exhaust filter cleaning mode:

1. Press home menu key on diagnostic gauge.
2. Press arrow keys to scroll up or down to FUNCTION.
3. Press check mark select key.
4. Press arrow keys to scroll up or down to EXHAUST REGENERATION.
5. Press check mark select key.
6. Press arrow keys to scroll up or down to AUTOMATIC.
7. Press check mark select key to enable auto exhaust filter cleaning.

Manual/Parked Exhaust Filter Cleaning

To request a manual/parked exhaust filter cleaning:

1. Reduce engine speed to slow idle.
2. Press home menu key on diagnostic gauge.
3. Press arrow keys to scroll up or down to FUNCTION.
4. Press check mark select key.
5. Press arrow keys to scroll up or down to EXHAUST REGENERATION.
6. Press check mark select key.
7. Press arrow keys to scroll up or down to FORCED.
8. Press check mark select key to request a manual/parked exhaust filter cleaning.
9. Follow directions on display and ensure all conditions are met.
10. Press check mark select key to CONFIRM all conditions are met.

Disable Exhaust Filter Cleaning

To disable the auto exhaust filter cleaning mode:

1. Press home menu key on diagnostic gauge.

2. Press arrow keys to scroll up or down to FUNCTION.
3. Press check mark select key.
4. Press arrow keys to scroll up or down to EXHAUST REGENERATION.
5. Press check mark select key.
6. Press arrow keys to scroll up or down to INHIBIT.
7. Press check mark select key to disable exhaust filter cleaning.
8. Press check mark select key to continue after the warning has been acknowledged.

Fault Codes — Active

To view active fault code information:

1. Press home menu key on diagnostic gauge.
2. Press arrow keys to scroll up or down to FUNCTION.
3. Press check mark select key.
4. Press arrow keys to scroll up or down to VIEW FAULT CODES.
5. Press check mark select key.
6. Press arrow keys to scroll up or down to ACTIVATE.
7. Press check mark select key.
8. Press arrow keys to scroll through available faults.

Fault Codes — Stored

To view stored fault code information:

1. Press (home) menu key on diagnostic gauge.
2. Press arrow keys to scroll up or down to FUNCTION.
3. Press (check mark) select key.
4. Press Arrow keys to scroll up or down to VIEW FAULT CODES.
5. Press (check mark) select key.
6. Press arrow keys to scroll up or down to STORED.
7. Press (check mark) select key.
8. Press Arrow keys to scroll through available faults.

BL90236,0000026 -19-19AUG21-1/1

PV480 Instrument Panel

John Deere PowerTech™ OEM engines have an electronic control system, which has controls and gauges as shown. The following information applies only to those controls and gauges supplied by John Deere. Refer to your engine application manual for specific guidelines if John Deere-sourced controls and instrumentation are not used.

The following is a brief description of the available optional electronic controls and gauges found on John Deere provided instrument panels. Refer to manufacturer's literature for information on controls not provided by John Deere.

Instrument Panel

A — Diagnostic Gauge

The diagnostic gauge (A) allows the operator to view fuel level, DEF level, engine parameters, diagnostic trouble codes (DTCs), and other engine functions. Gauge is linked to the electronic control system and its sensors. This allows the operator to monitor engine functions and to troubleshoot the engine systems when needed.

B — Arrow Keys

The arrow keys (B) allow the operator to select menu items.

C — Menu Key

The menu key (C) allows the operator to access the main menu of the diagnostic gauge.

D — Select Key

The select key (D) allows the operator to access menu items selected by the arrow keys (B) and confirm changes made by the operator.

E — Exit Key

The exit key (E) allows the operator to cancel an option and to go back to the previous menu.

F — Key Switch

PowerTech is a trademark of Deere & Company

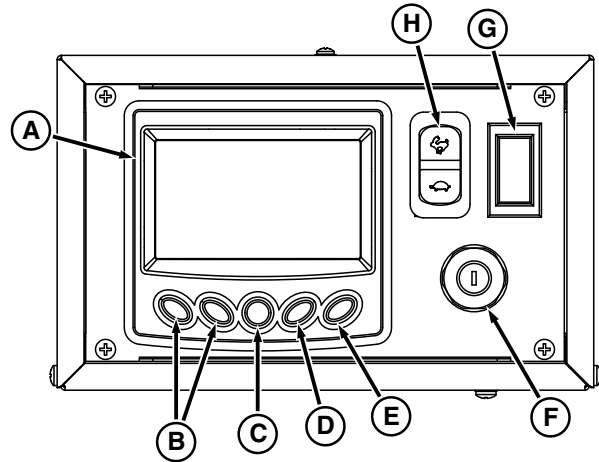

PV480 Instrument Panel

A—Diagnostic Gauge
B—Arrow Key (2 used)
C—Menu Key
D—Select Key

E—Exit Key
F—Key Switch
G—Cover
H—Speed Select Rocker Switch

The three-position key switch (F) controls the engine electrical system. When the key switch is turned clockwise to "START", the engine cranks. When the engine starts, the key switch is released and returns to the "ON" (RUN) position.

G — Cover

The cover (G) hides an expansion slot for an additional switch.

H — Speed Select Rocker Switch

The speed select rocker switch (H) is used to bump engine speed up (+) or down (-) in small increments during operation.

RG23644—UN—27AUG13

BL90236,0000003 -19-19AUG21-1/1

PV480 Diagnostic Gauge — Using

The diagnostic gauge (A) allow the operator to monitor engine functions, view diagnostic trouble codes (DTCs), and perform preliminary diagnostics. The gauge is linked to the electronic control system and sensors.

The arrow keys (B) allows the operator to scroll between menu items. The arrow keys automatically change from up and down, to left and right depending on the menu item to be selected.

The menu key (C) allows the operator to access the main menu of the diagnostic gauge. For more information, see PV480 Diagnostic Gauge — Main Menu in Section 15.

The select key (D) allows the operator to access menu items selected by the arrow keys (B) and confirm changes made by the operator.

The exit key (E) allows the operator to cancel an option and to go back to the previous menu.

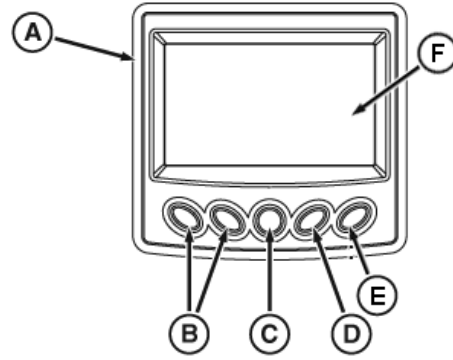

PV480 Diagnostic Gauge

A—Diagnostic Gauge
B—Arrow Key (2 used)
C—Menu Key

D—Select Key
E—Exit Key
F—Display

RG23474 —UN—06JUN13

BL90236.0000006 -19-19AUG21-1/1

PV480 Diagnostic Gauge — Main Menu

NOTE: The engine does not need to be running to navigate the diagnostic gauge screens.

The main menu is the starting point in accessing engine information and configuring the diagnostic gauge. Press the menu key (C) to access the main menu.

Use the arrow keys (B) and select key (D) to view menu items displayed:

- User Settings
- Faults
- Exhaust Filter
- Start Options
- Service
- Utilities

Listed are examples of features available in main menu items.

In User Settings:

- Date
- Time
- Language
- Units
- Brightness
- Ambient Light

In Check Faults:

- ActiveDTCs
- Stored DTCs

In Exhaust Filter:

- Status
- Auto exhaust filter clean
- Disable exhaust filter clean
- Request exhaust filter clean

In Start Options:

- Auto features
- Manual features
- Clock start
- Temperature start

In Service:

- Data list screens
- Engine hours
- Data logger
- Service reminders
- Harness diagnostics
- Component identification

In Utilities:

- System settings
- Pressure governing
- ECU software update
- Advanced settings (password protected)

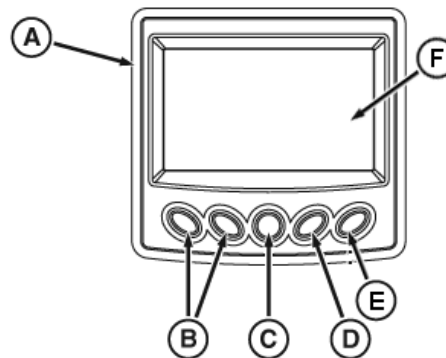

PV480 Diagnostic Gauge

- | | |
|----------------------|--------------|
| A—Diagnostic Gauge | D—Select Key |
| B—Arrow Key (2 used) | E—Exit Key |
| C—Menu Key | F—Display |

RG23474—UN—06JUN13

BL90236,0000001 -19-19AUG21-1/1

PV480 Diagnostic Gauge — Essential Menus

Automatic Exhaust Filter Cleaning

To enable auto exhaust filter cleaning mode:

1. Press Menu key on diagnostic gauge.
2. Press Arrow keys to scroll up or down to EXHAUST FILTER.
3. Press Select key.
4. Press Arrow keys to scroll up or down to AUTO EXH FLT CLEAN.
5. Press Select key to enable auto exhaust filter cleaning.

Manual/Parked Exhaust Filter Cleaning

To request a manual/parked exhaust filter cleaning:

1. Reduce engine speed to slow idle.
2. Press Menu key.
3. Press Arrow keys to scroll up or down to EXHAUST FILTER.
4. Press Select key.
5. Press Arrow keys to scroll up or down to REQUEST EXH FLT CLEAN.
6. Press Select key to request a manual/parked exhaust filter cleaning.
7. Follow directions on display and ensure all conditions are met.
8. Press Select key to CONFIRM all conditions are met.

Disable Exhaust Filter Cleaning

To disable the auto exhaust filter cleaning mode:

1. Press Menu key on diagnostic gauge.
2. Press Arrow keys to scroll up or down to EXHAUST FILTER.
3. Press Select key.
4. Press Arrow keys to scroll up or down to DISABLE EXH FLT CLEAN.
5. Press Select key to disable exhaust filter cleaning.

Fault Codes — Active

To view active fault code information:

1. Press Menu key on diagnostic gauge.
2. Press Arrow keys to scroll up or down to FAULTS.
3. Press Select key.
4. Press Arrow keys to scroll up or down to ACTIVE FAULTS.
5. Press Select key.
6. Press Arrow keys to scroll through available faults.

Fault Codes — Stored

To view stored fault code information:

1. Press Menu key on diagnostic gauge.
2. Press Arrow keys to scroll up or down to FAULTS.
3. Press Select key.
4. Press Arrow keys to scroll up or down to STORED FAULTS.
5. Press Select key.
6. Press Arrow keys to scroll up or down to VIEW.
7. Press Select key.
8. Press Arrow keys to scroll through available faults.

BL90236,0000024 -19-19AUG21-1/1

Required Machine Stop Warning

RG22491 —UN—21AUG13

Machine Stop Mandate Occurs

IMPORTANT: In some situations, machine engine power is reduced as described. On notification, immediately place the machine in a safe state and or move it to a safe location. A mandated machine stop can only be removed by a service technician.

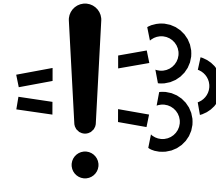

Engine Emissions System Malfunction Indicator illuminates when an emission-related fault occurs.

DX,MACHSTOPWARN,OEM -19-02OCT15-1/8

Warning Indicator illuminates when a condition exists which requires operator action.

RG22492 —UN—21AUG13



Continued on next page

DX,MACHSTOPWARN,OEM -19-02OCT15-2/8

Engine Stop Indicator illuminates when a condition exists which requires immediate operator action and service.

RG22493 —UN—21AUG13

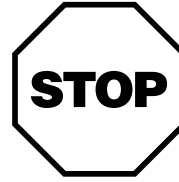

DX,MACHSTOPWARN,OEM -19-02OCT15-3/8

Emission System Fault Has Occurred

RG26361 —UN—04SEP14

0—2 hours, the Engine Emissions System Malfunction and Warning Indicators are illuminated to warn operator of presence of emissions-related fault. If equipped, an alarm sounds.

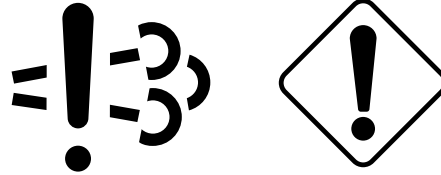

DX,MACHSTOPWARN,OEM -19-02OCT15-4/8

After 2 hours, performance is reduced. Engine Emissions System Malfunction and Engine Stop Indicators are illuminated to warn operator of emissions-related fault. If equipped, an alarm sounds. Full machine performance is restored with Ignition OFF, Engine OFF, Ignition ON, Engine ON.

RG26972 —UN—26MAR15

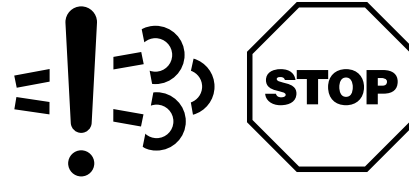

DX,MACHSTOPWARN,OEM -19-02OCT15-5/8

After 3 hours 50 minutes, performance is reduced. Engine Emissions System Malfunction and Engine Stop Indicators are illuminated to warn operator of emissions-related fault which has not been corrected. If equipped, an alarm sounds.

RG26972 —UN—26MAR15

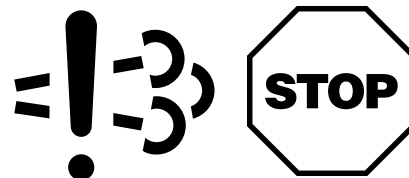

DX,MACHSTOPWARN,OEM -19-02OCT15-6/8

Emission System Fault Occurs Within 40 Hours of Previous Fault

RG26972 —UN—26MAR15

0—10 minutes, performance is reduced. Engine Emissions System Malfunction and Engine Stop Indicators are illuminated to warn operator of emissions-related fault. If equipped, an alarm sounds. Full machine performance is restored with Ignition OFF, Engine OFF, Ignition ON, Engine ON.

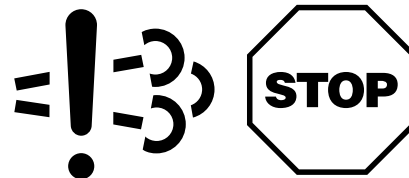

Continued on next page

DX,MACHSTOPWARN,OEM -19-02OCT15-7/8

30 minutes, performance is reduced. Engine Emissions System Malfunction and Engine Stop Indicators are illuminated to warn operator of emissions-related fault which has not been corrected. If equipped, an alarm sounds.

RG26972 —UN—26MAR15

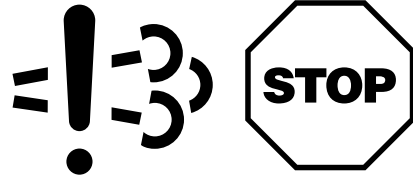

DX,MACHSTOPWARN,OEM -19-02OCT15-8/8

John Deere PowerSight

John Deere PowerSight is a web based service that allows remote access to machine data. John Deere PowerSight is accessible from a laptop, desktop or mobile device.

John Deere PowerSight works by combining a controller that includes cellular communication and GPS antennas. Machine data is collected by the controller and wirelessly transferred to a data server, where it is made available on a website.

John Deere PowerSight allows you to:

- Stay informed on machine location and hours
- Protect assets with Geofence and Curfew alerts
- Keep assets running with maintenance tracking and preventive maintenance plans
- Track and analyze machine and fuel usage
- Conduct remote machine diagnostics and programming

For more information and availability, contact an authorized John Deere dealer or servicing dealer.

BL90236,0000031 -19-13FEB14-1/1

Engine Operation

Break-In Service

Extra care during the first 100 hours of operation results in satisfactory long-term engine performance and life.

1. This engine is factory-filled with John Deere Break-In Plus™ oil. Operate the engine at heavy loads with minimal idling during the break-in period.
2. If the engine has significant operating time at idle, constant speeds, and/or light load usage, or additional oil is required in the first 100 hour period, a longer break-in period may be required. In these situations, an additional 100 hour break-in period is recommended using a new change of John Deere Engine Break-In Plus Oil and a new John Deere oil filter.
3. Check oil more frequently during engine break-in period. If oil must be added during this period, John Deere Break-In Plus Oil is preferred. See John Deere Break-In Plus™ Engine Oil — Interim Tier 4, Final Tier 4, Stage IIIB, and Stage IV in the Fuels, Lubricants, and Coolants Section for other oils allowed.

IMPORTANT: DO NOT fill above the top of the crosshatch pattern or the FULL mark, whichever is present. Oil levels anywhere within crosshatch are considered in the acceptable operating range. John Deere Break-In Plus engine oil should be used to make up any oil consumed during the break-in period.

4. During the first 20 hours, avoid prolonged periods of engine idling. If engine idles longer than 5 minutes, stop engine.
5. During the initial operation of a new or rebuilt engine with Break-In Plus, change the oil and filter between a minimum of 100 hours and a maximum of up to

500 hours (B). (Top-load oil filter illustrated.) (See Changing Engine Oil and Replacing Filter in the Lubrication & Maintenance — 500 Hours/12 Months Section.) Fill crankcase with seasonal viscosity grade oil. (See Diesel Engine Oil — Interim Tier 4, Final Tier 4, Stage IIIB, and Stage IV in the Fuels, Lubricants, and Coolants Section.)

NOTE: Some increase in oil consumption may be expected when low viscosity oils are used. Check oil levels more frequently.

If temperature is below 0 °C (32 °F), it may be necessary to use cold weather starting aids (See Cold Weather Operation in the Engine Operation Section).

If air temperature is below 0 °C (32 °F), use an engine block heater.

6. Watch coolant temperature gauge closely during engine operation. If coolant temperature rises above 113 °C (235 °F), the engine reduces power automatically. Unless temperature drops quickly, stop the engine and determine the cause before resuming operation.

Monitor oil pressure and coolant temperature to ensure that they are within specification.

Specification

Engine —Oil Pressure at	
Full Load Rated Speed.....	370 kPa (3.70 bar) (54 psi)
Minimum Oil Pressure at	
Low Idle	150 kPa (1.50 bar) (22 psi)
Coolant Temperature	
Range.....	85°–97 °C (185°–207 °F)

7. Check belt for proper seating in pulley grooves.

Break-In Plus is a trademark of Deere & Company

AT89373,0000002 -19-08FEB18-1/1

Generator Set (Standby) Applications

To assure that the engine will deliver efficient standby generator operation when needed, start engine and run at rated speed (with 50%—70% load) for 30 minutes every 2 weeks. DO NOT allow engine to run for an extended period of time with no load.

Biodiesel fuel is not recommended for standby equipment that can have minimal fuel consumption (such as standby generators, fire protection, etc.). For standby applications,

use only petroleum based diesel fuel with John Deere approved fuel conditioners and additives. For fuel conditioners and additives, check with the local John Deere dealer.

Petroleum diesel fuel should not be stored in service tanks longer than two years even when using fuel additives. See the fuel distributor or John Deere dealer for more information.

RK80614,0000009 -19-11AUG21-1/1

Starting the Engine

NOTE: The controls and instruments for your engine may be different from those shown here; always follow manufacturer's instructions.

The following instructions apply to the optional controls and instruments available through the John Deere Parts Distribution Network.

CAUTION: Before starting engine in a confined building, install proper outlet exhaust ventilation equipment. Always use safety approved fuel storage and piping.

NOTE: If temperature is below 0 °C (32 °F), it may be necessary to use cold weather starting aids. See *Cold Weather Operation* in the *Engine Operation* Section.

1. Perform all prestarting checks outlined in Lubrication & Maintenance/Daily Section later in this manual.

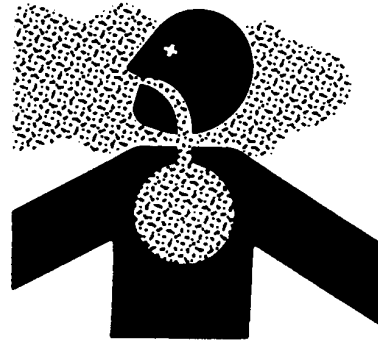

Use Proper Ventilation

2. Open the fuel supply shutoff valve, if equipped.
3. Disengage power (or clutch if equipped) to any engine drive lines.

RK80614,000000A -19-18AUG14-1/2

4. Set high-low speed select rocker switch (H) to slow (turtle), then push in on analog throttle handle or turn full counterclockwise to set analog throttle(s) to slow speed.

IMPORTANT: Do not operate the starter for more than 30 seconds at a time. To do so may overheat the starter. If the engine does not start the first time, wait at least 2 minutes before trying again. If engine does not start after four attempts, see *Engine Troubleshooting* in the *Troubleshooting* Section.

5. Turn the key start switch clockwise to the "ON" position. Wait until the Engine Preheater Indicator light turns off, then turn the key start switch (F) clockwise "START" position to crank the engine. In cold weather, preheater indicator light remains on longer while engine is warmed. See *Cold Weather Operation* in the *Engine Operation* Section. When the engine starts, release the key switch so that it returns to the "ON" position.

IMPORTANT: If the key switch is released before the engine starts, wait until the starter and the engine stop turning before trying again. This prevents possible damage to the starter and/or flywheel.

6. After engine starts, idle engine at not more than 1200 rpm until warm. See *Warming Engine* in the *Engine Operation* Section.

Set either high-low speed select switch or analog throttle to slow speed, and set desired speed with remaining control. See *Changing Engine Speed* in the *Engine Operation* Section.

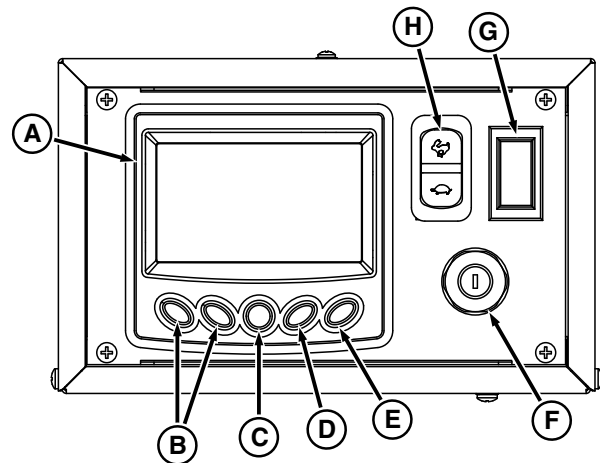

- | | |
|--------------------|------------------------------|
| A—Diagnostic Gauge | E—Exit Key |
| B—Arrow Keys | F—Key Switch |
| C—Menu Key | G—Cover |
| D—Select Key | H—Speed Select Rocker Switch |

NOTE: Engine control unit (ECU) reads the higher of the high-low speed select rocker switch or the analog throttle speed settings.

7. Check all gauges for normal engine operation. If operation is not normal, stop the engine and determine the cause. For normal gauge pressures and temperatures, see *Break-In Service* in the *Engine Operation* Section.

RK80614,000000A -19-18AUG14-2/2

Normal Engine Operation

Observe engine coolant temperature and engine oil pressure. Temperatures and pressures will vary between engines and with changing operating conditions, temperatures, and loads.

Normal engine coolant operating temperature range is 85°–97 °C (185°–207 °F). If coolant temperature rises above 105 °C (221 °F), engine will reduce power automatically. Unless temperature drops quickly, stop engine and determine cause before resuming operation.

Operate the engine under a lighter load and at slower than normal speed for first 15 minutes after start-up. DO NOT run engine at slow idle.

Stop engine immediately if there are any signs of part failure. Symptoms that may be early signs of engine problems are:

- Sudden drop in oil pressure
- Abnormal coolant temperatures
- Unusual noise or vibration
- Sudden loss of power
- Excessive fuel consumption
- Excessive oil consumption
- Fluid leaks

NOTE: A revving sound may be heard for an instant after starting, as the variable geometry turbocharger cycles; which is normal.

ZE59858,00000AC -19-31JUL13-1/1

Warming Engine

IMPORTANT: To assure proper lubrication, operate engine at or below 1200 rpm with no load for 1–2 minutes. Extend this period 2–4 minutes when operating at temperatures below freezing.

Engines used in generator set applications where the governor is locked at a specified speed may not have a slow idle function. Operate these engines at fast idle for 1–2 minutes before applying the load. This procedure does not apply to standby generator sets where the engine is loaded immediately upon reaching rated speed.

1. Check oil pressure gauge as soon as engine starts. If gauge needle does not rise above minimum oil pressure specification of 150 kPa (1.50 bar) (22 psi) within 5 seconds, stop the engine and determine

the cause. Normal engine oil pressure is measured at rated full load speed (1800–2500 rpm) with oil at normal operating temperature of 97 °C (207 °F).

Specification

Oil Pressure—Oil	
Pressure at Full Load	
Rated Speed—Oil	
Pressure at Full Load	
Rated Speed.....	224—401 kPa (2.24—4.01 bar) (32—58 psi)

2. Watch coolant temperature gauge. Do not place engine under full load until it is properly warmed up. The normal engine coolant temperature range is 85°–97 °C (185°–207 °F).

NOTE: It is a good practice to operate the engine under a lighter load and at lower speeds than normal for the first few minutes after start-up.

ZE59858,00000AD -19-14JAN20-1/1

Idling Engine

Avoid excessive engine idling. Prolonged engine idling may cause the engine coolant temperature to fall below its normal range. This in turn, causes crankcase oil dilution, due to incomplete fuel combustion and permits formation of gummy deposits on valves, pistons, and piston rings. It also promotes rapid accumulation of engine sludge and unburned fuel in the exhaust system.

Once an engine is warmed to normal operating temperatures, engine should be idled at slow idle speed. Slow idle speed for this engine is set at the factory at 800 rpm for standard industrial engines and at 850 rpm for generator sets. If an engine will be idling for more than five minutes, stop and restart later.

To reduce buildup of soot while operating at slow idle speed, ECU increases engine operating speed to rated speed whenever DOC face plugging is possible. Increased engine operating speed increases exhaust temperature and ability to burn soot from DOC face.

NOTE: Generator set applications where the governor is locked at a specified speed may not have a slow idle function. These engines idle at no load governed speed (high idle).

AT89373,0000F7E -19-09FEB16-1/1

Changing Engine Speed

NOTE: On engines with 2-position throttles, speeds are not adjustable. These throttles allow operation only at the preset rated speed or at idle using the single switch.

- For slow speed, press lower half of speed select rocker switch (H) (indicated by turtle symbol).
- For fast speed, press upper half of speed select rocker switch (H) (indicated by rabbit symbol).
- Navigate the diagnostic gauge (A) to appropriate home screen. Adjust engine Set Speeds with arrow keys (B).

- | | |
|----------------------|------------------------------|
| A—Diagnostic Gauge | E—Exit Key |
| B—Arrow Key (2 used) | F—Key Switch |
| C—Menu Key | G—Cover |
| D—Select Key | H—Speed Select Rocker Switch |

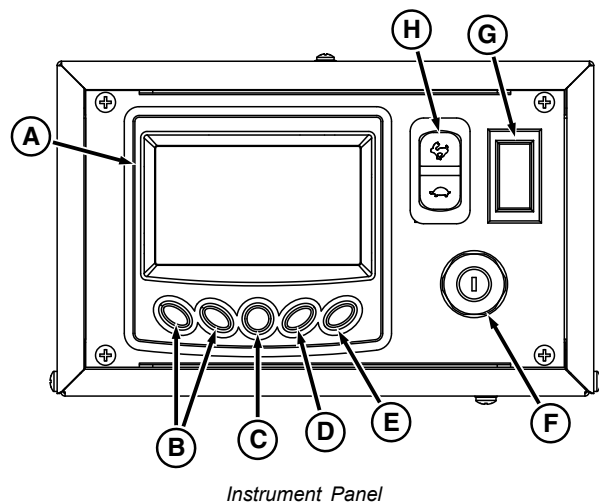

RG23644—UN—27AUG13

RK80614,000000F -19-19AUG21-1/1

Stopping the Engine

NOTE: Engines in generator set applications where the ECU is locked at a specified speed and no slow idle function is available, run engine for at least 2 minutes at fast idle and no load. If an Exhaust Filter Cleaning has just been performed, increase engine idle time to 4 minutes. If service work is going to be performed on the Exhaust Filter, increase engine idle time to 10 minutes

1. Run engine at 1000—1200 rpm for at least 2 minutes to cool. If an Exhaust Filter Cleaning has just been performed, increase engine idle time to 4 minutes. If service work is going to be performed on the Exhaust Filter, increase engine idle time to 10 minutes

Set rpm using bump speed enable switch (H).

2. Turn key start switch (F) to "OFF" position to stop the engine. Remove ignition key.

IMPORTANT: Make sure that exhaust stack rain cap is installed when engine is not running. This will prevent water and dirt from entering engine.

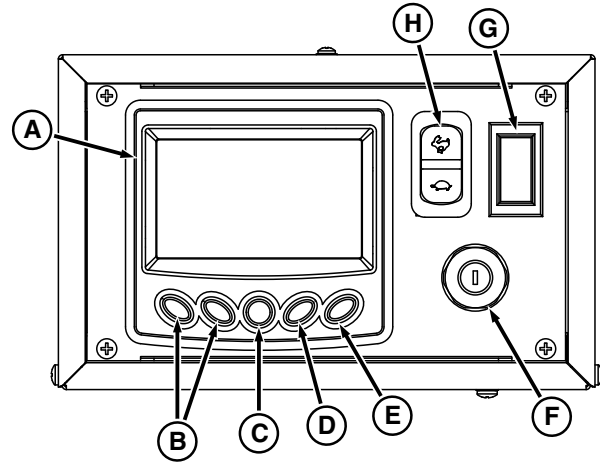

A—Diagnostic Gauge
B—Arrow Keys
C—Menu Key
D—Select Key

E—Exit Key
F—Key Switch
G—Cover
H—Speed Select Rocker Switch

RG23644 —UN—27AUG13

ZE59858,00000AE -19-18AUG14-1/1

Using a Booster Battery or Charger

A 12 volt booster battery or charger can be connected in parallel with battery(ies) on the unit to aid in cold weather starting. ALWAYS use heavy-duty jumper cables.

CAUTION: Gas given off by battery is explosive. Keep sparks and flames away from battery. Before connecting or disconnecting a battery charger, turn off charger. Make last connection and first disconnection at a point away from battery. Always connect NEGATIVE (–) cable last and disconnect this cable first.

WARNING: Battery posts, terminals, and related accessories contain lead and lead compounds, chemicals known to the State of California to cause cancer and reproductive harm. Wash hands after handling.

IMPORTANT: Be sure that polarity is correct before making connections. Reversed polarity damages electrical system. Always connect positive to positive and negative to ground. Always use 12 volt booster battery for 12 volt electrical systems and 24 volt booster battery(ies) for 24 volt electrical systems.

1. Connect booster battery or batteries to produce the required system voltage for your engine application.

NOTE: To avoid sparks, DO NOT allow the free ends of jumper cables to touch the engine.



Exploding Battery

2. Connect one end of jumper cable to the POSITIVE (+) post of the booster battery.
3. Connect the other end of the jumper cable to the POSITIVE (+) post of battery connected to starter.
4. Connect one end of the other jumper cable to the NEGATIVE (–) post of the booster battery.
5. ALWAYS complete the hookup by making the last connection of the NEGATIVE (–) cable to a good ground on the engine frame and away from the battery(ies).
6. Start the engine. Disconnect jumper cables immediately after engine starts. Always disconnect NEGATIVE (–) cable first.

TS204 —UN—15APR13

ZE59858,0000011 -19-18AUG14-1/1

Auxiliary Gear Drive Limitations

IMPORTANT: When attaching an air compressor, hydraulic pump, or other accessory to be driven by the auxiliary gear drive (engine timing gear train at front of engine), power requirements of the accessory must be limited to values listed below:

IMPORTANT: See OEM engine distributor for more information to prevent overloading the auxiliary drive. Severe engine damage could result.

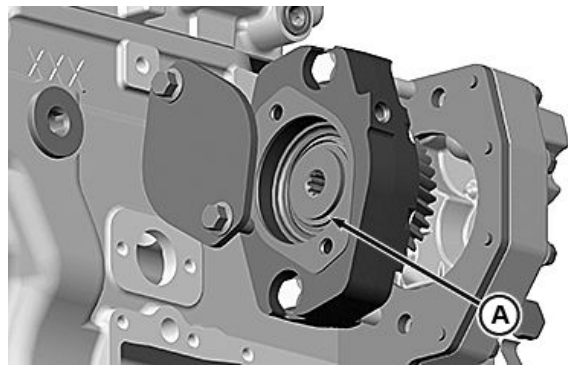

Auxiliary Gear Drive

A—Auxiliary Gear Drive

RG26289 —UN—12AUG14

SAE Drive	Continuous Power (Maximum)	Intermittent Power (Maximum)
A	30 kW (40 hp) at 2500 rpm	37 kW (50 hp) at 2500 rpm

ZE59858,0000012 -19-12AUG14-1/1

Aftertreatment System

Exhaust Filter Cleaning and Maintenance

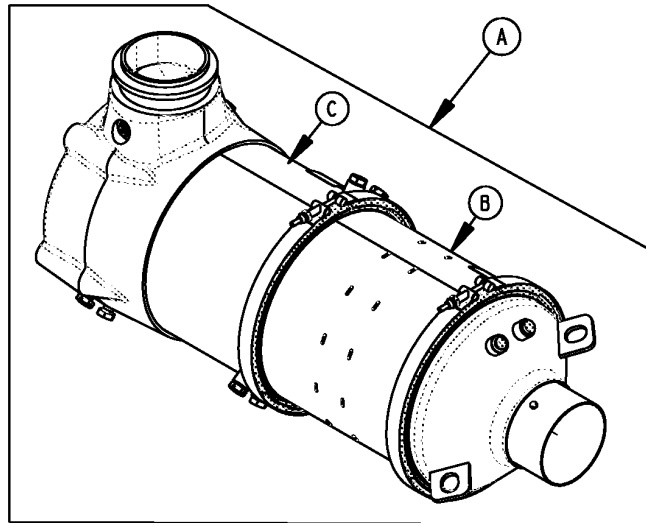

Exhaust Filter

- A—Exhaust Filter
B—Diesel Particulate Filter (DPF)
C—Diesel Oxidation Catalyst (DOC)

The purpose of these instructions is to provide proper management of ash generated by the exhaust filter (or “filter”) along with its proper disposal.

RK80614.0000013 -19-16OCT12-1/1

Exhaust Filter — Cleaning

NOTE: Some engine models are not equipped with a diesel particulate filter (DPF).

The diesel particulate filter (DPF) is a critical component in the engine’s emissions control system, which is required to meet governmental emissions regulations. The exhaust filter captures diesel particulate matter or “soot” to prevent

its release into the atmosphere. This soot must be eliminated from the DPF to keep it functioning properly. The process of eliminating collected soot is carefully controlled by the engine control unit (ECU) and is called “exhaust filter cleaning” or “regeneration”. During this process, a rise in exhaust temperature occurs and allows the soot to be oxidized within the DPF.

AT89373.0000F46 -19-11DEC15-1/1

RES3721TMDA02—UN—04MAR10

Diesel Particulate Filter Maintenance and Service

NOTE: Some engine models are not equipped with a diesel particulate filter (DPF).

The DPF is designed to retain residual ash, which is a noncombustible result of additives used in crankcase lubrication oils and the fuel. The DPF provides many hours of maintenance free operation. At some point the DPF will require professional service to remove the accumulated ash. The exact number of hours of operation before service is required will vary depending upon the engine's power category, duty cycle and operating conditions, engine oil ash content, and fuel quality. Adhering to John Deere's recommended oil and fuel specifications will maximize the hours of operation before professional DPF service is required.

As the engine owner, you are responsible for performing the required maintenance described in your operator's manual. The exhaust filter's dash lamp indicator or the

diagnostic codes will indicate when the DPF needs ash removal service. Generally, the ash removal service interval will far exceed the EPA required minimums of 3,000 hours for engines below 175hp/130kW and 4,500 hours for engines at or above 175hp/130kW.

The removal of DPF ash must be done by removing the DPF from the machine and placing it into specialized equipment. Do not remove ash by using water or other chemicals. Removing ash by these methods may damage the material securing the DPF in its canister, resulting in the loosening of the DPF element in the canister and subjecting it to damage from vibration.

Failure to follow the approved ash removal methods may violate U.S. federal, state and local hazardous waste laws, along with damage to the DPF resulting in potential denial of the diesel exhaust filter emissions warranty. It is strongly recommended you take the DPF to an authorized John Deere service location or other qualified service provider for servicing.

AT89373,0000F47 -19-11DEC15-1/1

Exhaust Filter — Diesel Particulate Filter Ash Handling and Disposal

CAUTION: Your Governing Bodies Regulations may classify diesel particulate filter ash as a hazardous waste. Hazardous wastes therefore must be disposed of in accordance with all applicable Governing Bodies Regulations governing hazardous waste disposal. Only a

qualified service provider should remove ash from the DPF. Personal protective equipment and clothing, maintained in a sanitary and reliable condition, should be used when handling and cleaning a DPF. See your John Deere dealer or qualified service provider for assistance.

RK80614,0000016 -19-05JUN13-1/1

Exhaust Filter — Disposal

CAUTION: Proper management of an Exhaust Filter that has reached the end of its useful life is required, since the ash or catalyst material

in the device may be classified as hazardous waste under federal, state, and/or local laws or regulations. See your John Deere dealer or qualified service provider for assistance.

RK80614,0000017 -19-21OCT13-1/1

Exhaust Filter System Overview

NOTE: Operator display icons and procedures can vary in other applications. The information contained in this section specifically applies to only OEM engines using the diagnostic gauge. If you are operating

a John Deere vehicle, please see the vehicle operator manual for all exhaust filter cleaning operation information and procedures.

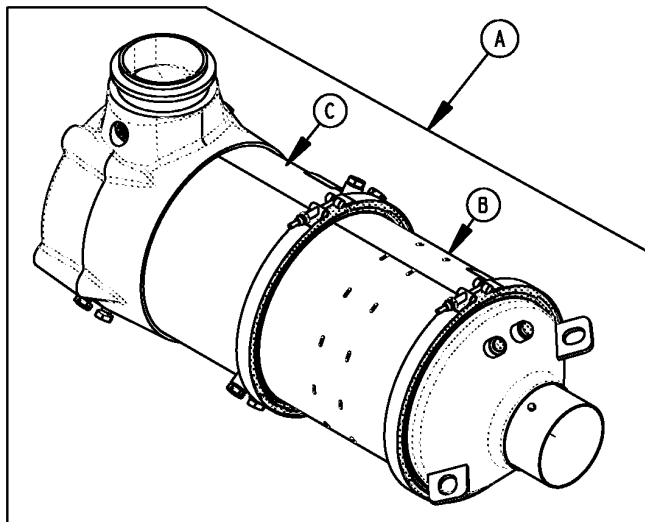

Diesel Exhaust Filter

A—Diesel Exhaust Filter

B—Diesel Particulate Filter (DPF) C—Diesel Oxidation Catalyst (DOC)

NOTE: Some engine models are not equipped with a diesel particulate filter (DPF).

John Deere has developed an exhaust filter consisting of a diesel oxidation catalyst (DOC) and a diesel particulate filter (DPF) specifically to meet the demands of off-highway applications. The DOC reduces carbon monoxide, hydrocarbons, and some particulate matter. The downstream DPF traps and holds particulates remaining in the exhaust stream. Trapped particles are eventually oxidized within the DPF through a process known as regeneration or exhaust filter cleaning.

Under normal machine operation and with the system in AUTO mode, the exhaust filter system requires minimal operator interaction.

To avoid unnecessary buildup of diesel particulates or soot in the exhaust filter system;

- 1 — Utilize automatic (AUTO) exhaust filter cleaning mode.
- 2 — Avoid unnecessary idling.
- 3 — Use proper engine oil (See Fuels, Lubricants, and Coolants Section for recommendations).
- 4 — Use only ultra low sulfur fuel (See Fuels, Lubricants, and Coolants Section for recommendations).

In addition to soot, ash deposits will also slowly build up in the DPF and cannot be removed through the engine exhaust filter cleaning process. To clean the ash deposits from the DPF see [Diesel Particulate Filter Maintenance and Service](#) in the Aftertreatment Section.

CAUTION: Do not power wash the filter assembly when external skin temperature of assembly exceeds 50°C (120°F).

AT89373.0000F48 -19-11DEC15-1/1

RE537721TMDA02 — UN — 04MAR10

Selective Catalytic Reduction (SCR) System Overview

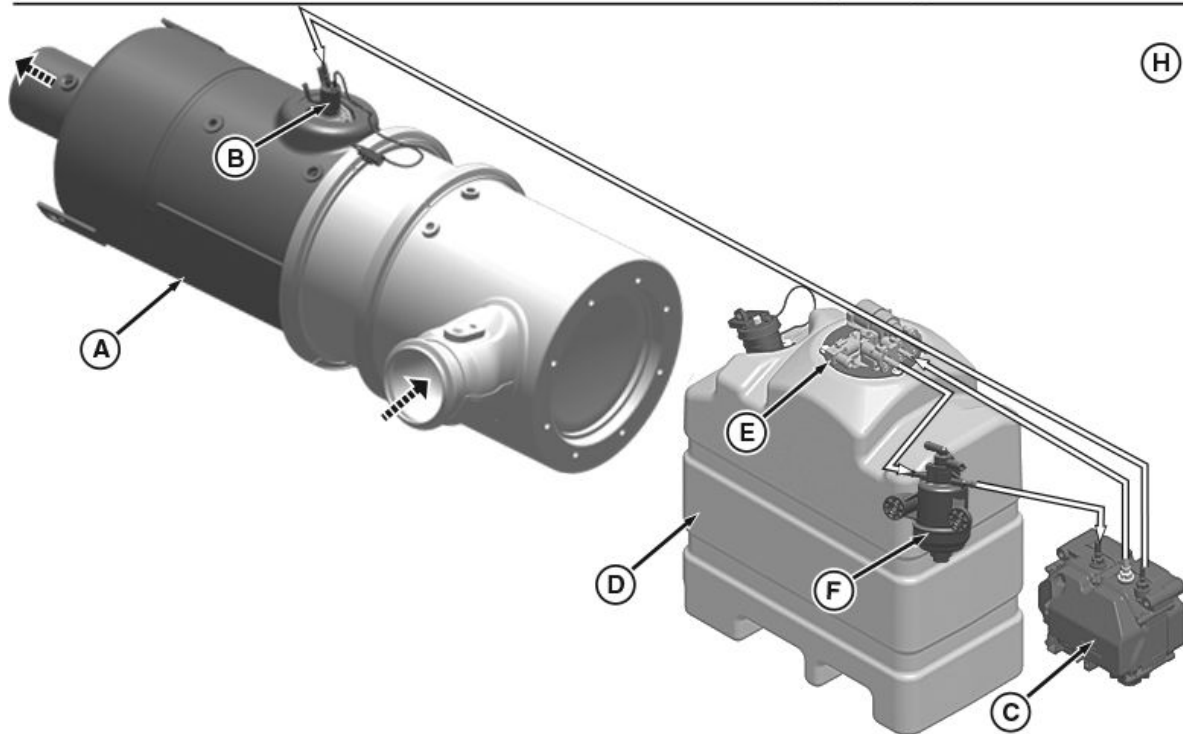
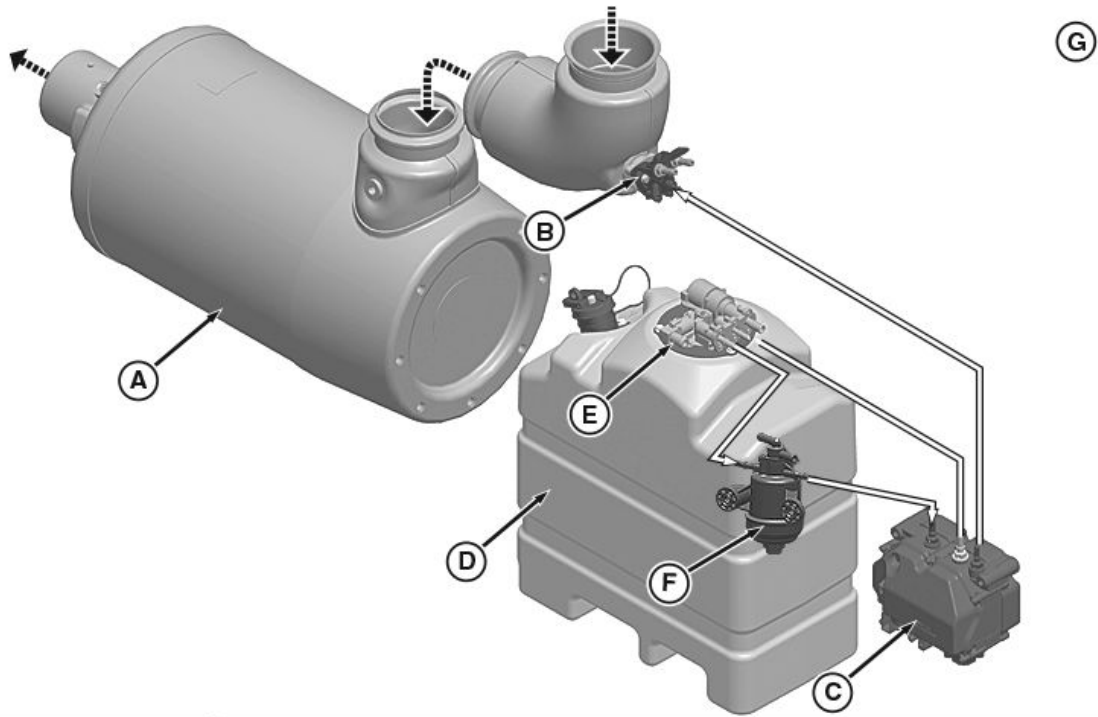

SCR System

- A—SCR Catalyst
- B—DEF Dosing Injector
- C—DEF Dosing Unit
- D—DEF Tank
- E—DEF Tank Header Assembly
- F—Inline DEF Filter (If Equipped)
- G—Modular Canning Configuration
- H—Inline Canning Configuration

Continued on next page

DX,SCR,OVERVIEW -19-30MAR20-1/2

RG22427A—UN—07JAN20

IMPORTANT: Do not remove battery leads for at least 4 minutes after engine stops. The SCR system automatically purges itself of Diesel Exhaust Fluid (DEF) immediately after the engine is stopped. If adequate time is not allowed for lines to be purged, residual DEF can freeze and possibly damage components of the SCR system during cold-weather exposure.

In order to comply with national and local emission requirements, this engine series contains a Selective Catalytic Reduction (SCR) system. The main components of the SCR system include the SCR catalyst (A), DEF dosing injector (B), DEF dosing unit (C), DEF tank (D), and DEF tank header assembly (E). The SCR system is effective at reducing the nitrogen oxides (NOx) emissions. NOx is a major component of smog and acid rain.

During combustion, NOx molecules are formed in the exhaust. DEF is injected into the exhaust stream before the SCR catalyst. Through a chemical reaction in the SCR, NOx is converted into nitrogen and water.

Water vapor is a normal by-product of combustion. During cold-weather operation at low exhaust temperatures, this water vapor can condense and resemble white smoke from the exhaust. This will dissipate as operating temperature increases and the water is further vaporized. This situation is considered normal.

A DEF solution begins to crystallize and freeze at -11 °C (12 °F). With climate temperatures that can range much colder than this, DEF is expected to freeze in the DEF tank. For this reason, the DEF tank contains a heating element that provides rapid thawing of DEF upon start-up. The heating element cycles to maintain fluidity during operation as needed. DEF is not dosed upon initial start-up, therefore it is not necessary to have liquid DEF at cold start-up.

If DEF quality deteriorates and it is no longer within specifications, the engine can derate. DEF should be crystal clear with a light ammonia smell. If DEF appears cloudy, has a colored tint, or has a profound ammonia smell, it is likely not within specification.

DX,SCR,OVERVIEW -19-30MAR20-2/2

Diagnostic Gauge Keys and Indicators Overview

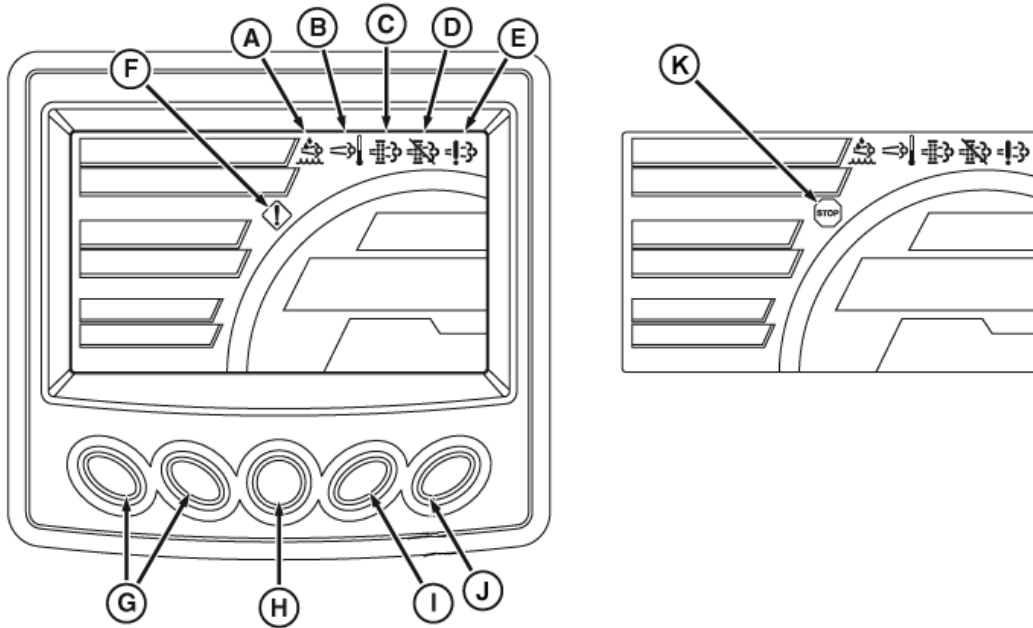

Diagnostic Gauge Indicators and Keys

- | | | | |
|---|--|----------------------------|-------------------------|
| A—Diesel Exhaust Fluid (DEF) Indicator | C—Exhaust Filter Indicator | F—Caution Indicator | K—Stop Indicator |
| B—Engine Emissions Temperature Indicator | D—Auto Cleaning Disable Indicator | G—Arrow Keys | |
| | E—Engine Emissions System Malfunction Indicator | H—Menu Key | |
| | | I—Select Key | |
| | | J—Exit Key | |

NOTE: You will never see the diagnostic gauge with all indicators illuminated at the same time (as shown). This image is only to illustrate the indicators you may see during operation.

The image above shows the keys and indicators you will see and use on the diagnostic gauge.

The diesel exhaust fluid indicator (A), engine emissions temperature indicator (B), exhaust filter indicator (C), auto cleaning disable indicator (D), engine emissions system malfunction indicator (E) and the caution indicator

(F) provide the operator with visual notifications and aftertreatment system operations. The Arrow keys (G) are used to scroll up or down between options on the diagnostic gauge screen. The Menu key (H) is used to access the main menu of options from which the operator can choose. The Select key (I) is used when selecting an option on the diagnostic gauge. The Exit key (J) is used to come out from an option on the diagnostic gauge. The Stop Indicator (K) is flashed when the soot level of exhaust filter becomes extremely high and the ECU lowers the performance of engine.

RK80614,0000019 -19-05JUL13-1/1

RG23756—UN—05JUL13

Aftertreatment Indicators Overview

IMPORTANT: The operator will be informed by the operator warning system when the emission control system does not function correctly and/or an engine malfunction is detected by the engine control unit. Ignoring the operator warning signals will lead to an emission related derate, resulting in an effective disablement of non-road mobile machinery operation.

It is essential to take prompt action to rectify any incorrect operation, use or maintenance of the emissions control system in accordance with the rectification measures indicated by the warnings referenced below.

The Diesel Exhaust Fluid (DEF) indicator illuminates when the DEF is low. Fill DEF tank.

When the DEF indicator is combined with the warning indicator or engine stop indicator engine performance is reduced by the Engine Control Unit (ECU) because the DEF is below a measurable level. Fill DEF tank.

When engine emissions temperature indicator illuminates exhaust gas temperature is high, elevated idle is active, or exhaust filter cleaning is in process. The machine can be operated as normal unless the operator determines the machine is not in a safe location for high exhaust temperatures and disables auto cleaning.

When engine emissions temperature indicator is combined with the warning indicator or engine stop indicator engine performance is reduced by the ECU because the exhaust gas temperature is higher than expected. Follow Diagnostic Trouble Code (DTC) procedure or see your authorized servicing dealer.

When the exhaust filter indicator illuminates the exhaust filter cleaning is in process, aftertreatment system has a fault, or the exhaust filter is in need of cleaning and the operator has disabled auto exhaust filter cleaning. If conditions are safe, the operator should enable the auto exhaust filter clean setting or perform manual service regeneration or follow DTC procedure.

When the exhaust filter indicator is combined with the warning indicator engine performance is reduced by the ECU because there is an aftertreatment system fault or the soot level of the exhaust filter is moderately high. If conditions are safe, the operator should enable the auto exhaust filter clean function. If conditions are not safe, the operator should move the machine to a safe location and engage the auto exhaust filter cleaning mode. Perform manual service regeneration or follow DTC procedure.

When the exhaust filter indicator is combined with the engine stop indicator engine performance is further reduced by the ECU because there is an aftertreatment system fault or the soot level of the exhaust filter is extremely high. If this combination is present, see your authorized servicing dealer.

The auto cleaning disabled indicator illuminates when the operator has engaged the request to disable the

RG22487 —UN—21AUG13



Diesel Exhaust Fluid Indicator

RG22488 —UN—21AUG13

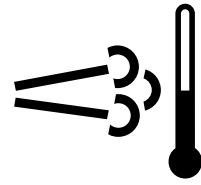

Engine Emissions Temperature Indicator

RG22489 —UN—21AUG13

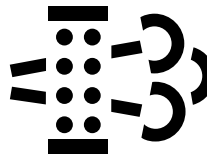

Exhaust Filter Indicator

RG22490 —UN—21AUG13

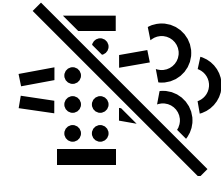

Auto Cleaning Disabled Indicator

RG22491 —UN—21AUG13

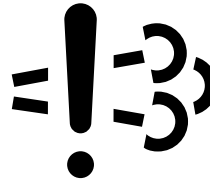

Engine Emissions System Malfunction Indicator

RG22492 —UN—21AUG13



Warning Indicator

RG22493 —UN—21AUG13

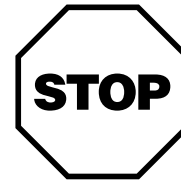

Engine Stop Indicator

auto exhaust filter cleaning function. This icon remains illuminated until the operator re-engages automatic exhaust filter cleaning from the diagnostic gauge. Disabling auto mode is not recommended for any situation unless it is safety-related or if the fuel tank lacks the required fuel to complete the cleaning process.

The engine emissions system malfunction indicator illuminates when engine emissions are outside of normal operating range or engine emissions system fault. Follow DTC procedure or see your authorized servicing dealer.

When the engine emissions system malfunction indicator is combined with the warning indicator engine performance is reduced by the ECU because the engine emissions are outside of normal operating range or engine emissions system fault. Follow DTC procedure or see your authorized servicing dealer.

Continued on next page

DX.AFTRTREAT,INDCATRS -19-12FEB18-1/2

Passive Regeneration

Periodically, the exhaust filter experiences higher temperature levels simply through the engine operating at higher loads. During these times, the higher exhaust temperature cleans a small amount of soot build-up in the exhaust filter. Conversely, unnecessary idling can

cause additional exhaust filter soot to accumulate. For the best possible engine operation which requires the least amount of operator interaction, work engine at higher load conditions whenever possible and keep idling to a minimum.

RK80614,000001A -19-09MAY16-1/1

Automatic (AUTO) Exhaust Filter Cleaning

NOTE: Operator display icons and procedures can vary in other applications. The information contained in this section specifically applies to only OEM engines. If you are operating a vehicle, please see the vehicle operator manual for exhaust filter cleaning and handling information and procedures.

Operating the engine in AUTO Mode allows the ECU to perform intelligent exhaust filter cleaning as required. The Exhaust Filter Cleaning Indicator will illuminate when the system is actively performing an exhaust filter cleaning. During this process, the doser will inject small amounts of fuel into the exhaust stream to assist in cleaning the exhaust filter. When the exhaust filter cleaning process has completed its cycle, the cleaning indicator will automatically turn off.

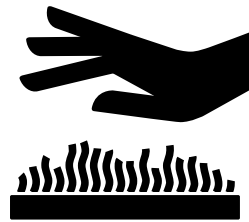

RG17488—UN—21AUG09

CAUTION:

Servicing machine or attachments during exhaust filter cleaning can result in serious personal injury. Avoid exposure and skin contact with hot exhaust gases and components.

During auto or manual/stationary exhaust filter cleaning operations, the engine will run at elevated idle and hot temperatures for approximately 30 minutes. Exhaust gases and exhaust filter components reach temperatures hot enough to burn people, ignite, or melt common materials.

CAUTION: If the machine is not in a safe location for elevated exhaust temperatures, move the machine to a safe location and check for adequate fuel level before beginning the exhaust filter cleaning process. Any PTO driven devices (if equipped) should be powered off or disconnected.

If the machine is not able to be moved into a safe location, the operator should temporarily disable auto exhaust filter cleaning (see Disable Exhaust Filter Cleaning later in this section). If the machine is located in a safe location, the auto mode should always be enabled.

JR74534,00001E7 -19-21MAR16-1/1

Manual/Parked Exhaust Filter Cleaning

NOTE: Operator display icons and procedures can vary in other applications. The information contained in this section specifically applies to only OEM engines. If you are operating a vehicle, please see the vehicle operator manual for exhaust filter cleaning and handling information and procedures.

Manual/Parked Exhaust Filter Cleaning is an automated process initiated at the request of the operator. This process allows the system to clean the exhaust filter when the operator previously needed to engage the disable exhaust filter cleaning because of specific conditions. During the process the engine speed will be controlled by the ECU and the machine must remain parked to complete the procedure. Time required for the Manual/Parked Exhaust Filter Cleaning process is dependent upon the level of exhaust filter restriction, ambient temperatures, and current exhaust gas temperature.

Complete cleaning times will vary on several criteria including fuel type, oil type, duty cycle, and the number of previously aborted exhaust filter cleaning requests. Average time for a standard cleaning can range from 20-50 minutes or longer.

CAUTION:

Servicing machine or attachments during exhaust filter cleaning can result in serious personal injury. Avoid exposure and skin contact with hot exhaust gases and components.

During auto or manual/parked exhaust filter cleaning operations, the engine will run at elevated idle and hot temperatures for approximately 30 minutes. Exhaust gases and exhaust filter components reach temperatures hot enough to burn people, ignite, or melt common materials.



RG17488 —JN—21AUG09

 CAUTION: Always park the machine in a safe location and check for adequate fuel level before beginning the exhaust filter cleaning process. Any PTO driven devices (if equipped) should be powered off or disconnected.

The exhaust filter indicator will remain off when Filter Cleaning is complete. If you are not returning the machine to service immediately after the procedure, allow the engine and the exhaust filter time to return to normal operating temperature before stopping engine. At any time during the parked procedure, the process can be canceled

Avoid disabling the cleaning procedure unless absolutely necessary. Repeated disabling or ignoring prompts to perform a manual/parked cleaning procedure will cause additional engine power limitations and can eventually lead to dealer required service.

Utilize Exhaust Filter Cleaning AUTO mode to avoid additional service.

JR74534,00001E8 -19-21MAR16-1/1

Disable Exhaust Filter Cleaning

NOTE: Operator display icons and procedures can vary in other applications. The information contained in this section specifically applies to only OEM engines. If you are operating a vehicle, please see the vehicle operator manual for exhaust filter cleaning and handling information and procedures.

NOTE: Disabling the exhaust filter cleaning request is not preferred. Disable the automatic exhaust filter

cleaning only when necessary. Whenever possible, cleaning should be allowed and the diagnostic gauge should be left in the auto mode. When left in auto mode, soot buildup in the exhaust filter system will be at a minimum.

NOTE: When AUTO or PARKED/MANUAL cleaning is enabled, the exhaust temperature may be high under no load or light load conditions at certain times during the exhaust filter cleaning cycle. Disable exhaust filter cleaning in conditions where it may be unsafe for elevated exhaust temperatures.

JR74534,00001E9 -19-21MAR16-1/1

Exhaust Filter Service Required

The exhaust filter cleaning procedures listed earlier in this section clean the soot from your exhaust filter. The exhaust filter also traps ash deposits over time which are not removed during an exhaust filter cleaning. When the exhaust filter has run several thousand hours, these

ash deposits can restrict engine performance due to increased back pressure. To correct this situation, replace the exhaust filter or have the exhaust filter cleaned in specialized equipment. See [Diesel Particulate Filter Maintenance and Service](#) in the Aftertreatment Section.

RK80614.000001E -19-11JUL13-1/1

Lubrication and Maintenance

Required Emission-Related Information

Service Provider

A qualified repair shop or person of the owner's choosing may maintain, replace, or repair emission control devices and systems with original or equivalent replacement parts. However, warranty, recall, and all other services paid for by John Deere must be performed at an authorized John Deere service center.

DX,EMISSIONS,REQINFO -19-12JUN15-1/1

Observe Service Intervals

In an emergency, where an authorized John Deere service location is not available, repairs may be performed at any available service establishment, or by the owner, using any replacement part, provided such parts are warranted by their manufacturer to be the equivalent of John Deere parts in performance and durability and the failure does not arise from the owner's failure to perform required maintenance.

Using hour meter (A) as a guide, perform all services at the hourly intervals indicated on following pages. At each scheduled maintenance interval, perform all previous maintenance operations in addition to the ones specified. Keep a record of hourly intervals and services performed, using charts provided in Lubrication and Maintenance Records section.

IMPORTANT: Recommended service intervals are for normal operating conditions. Perform maintenance at interval which occurs first, for example, either at 500 hours of operation or every 12 months. Service more often if engine operated under adverse conditions. Neglecting maintenance can result in failures or permanent damage to the engine.

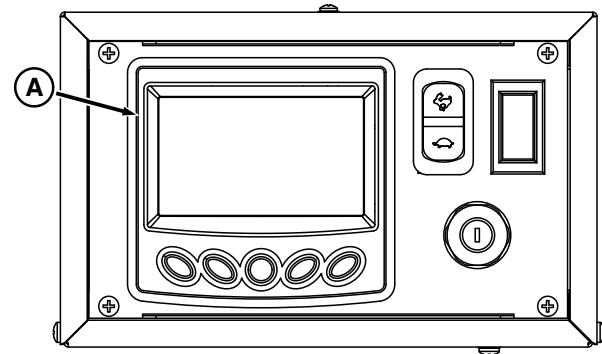

Hour Meter On Instrument Panel

A—Hour Meter

Perform all services at the hourly intervals. Record the services performed in the Lubrication and Maintenance Records Section. When scheduled service at any hourly level is performed, also perform all subordinate hourly level services.

See [Lubrication and Maintenance Service Interval Chart](#) in Group 30.

KP41357,000001F -19-15OCT19-1/1

RG22413 —UN—27AUG13

Use Correct Fuels, Lubricants, and Coolant

IMPORTANT: Use only fuels, lubricants, and coolants meeting specifications outlined in Fuels, Lubricants, and Coolant Section when servicing the John Deere Engine.

Consult the John Deere Servicing Distributor or the nearest John Deere Parts Network for recommended fuels, lubricants, and coolant. Also available are necessary additives for use when operating engines in tropical, arctic, or any other adverse conditions.



Liquid Products

RK80614,0000020 -19-11AUG21-1/1

RG17133 —UN—18MAY09

Lubrication and Maintenance Service Interval Chart

Item	Lubrication and Maintenance Service Intervals								
	Daily- /Before Every Startup	500 Hours of Op- eration or Ev- ery 12 Mon- ths	1500 Hours of Op- eration	1500 Hours of Op- eration or Ev- ery 36 Months	3000 Hours of Op- eration or Ev- ery 36 Months	4500 Hours of Op- eration or Ev- ery 36 Months	6000 Hours of Op- eration or Ev- ery 72 Mon- ths	8000 Hours of Op- eration or Ev- ery 36 Mon- ths	As Re- quired
Check Engine Oil	•								
Check Coolant Level	•								
Drain Water From Fuel Filters	•								
Check Air Cleaner Dust Valve Restriction Indicator Gauges	•								
Perform Inspection of Engine Compartment	•								
Service Fire Extinguisher		•							
Service Battery		•							
Change Engine Oil And Replace Oil Filter ^{a, b}		•							
Check Coolant Pump Weep Hole		•							
Check Open Crankcase Vent (OCV) System		•							
Replace Fuel Filter Elements		•							
Check Belt Tensioner and Belt Wear		•							
Check Cooling System		•							
Pressure Test Cooling System		•							
Check Engine Speeds		•							
Check Engine Mounts		•							
Check Engine Ground Connection		•							
Change Open Crankcase Ventilation (OCV) Filter ^c			•						
Change DEF Dosing Unit Filter						•			
Replace Inline DEF Filer								•	
Replace DEF Tank Header Suction Screen				•					
Adjust Engine Valve Clearance					•				
Test Glow Plugs for Continuity					•				
Flush and Refill Cooling System							•		
Test Thermostats							•		
Drain Water From Fuel Filters When Alarm Sounds									•
Add Coolant									•
Clean DEF Tank									•
Pre-Start Cleaning Guide									•
Service Air Cleaner Filter Elements									•
Clean Diesel Particulate Filter ^c									•
Replace Alternator/Fan Belt									•
Check Fuses									•

Continued on next page

KP41357,000001C -19-17DEC19-1/2

Lubrication and Maintenance

Item	Lubrication and Maintenance Service Intervals								As Re- quired
	Daily- /Before Every Startup	500 Hours of Op- eration or Ev- ery 12 Mon- ths	1500 Hours of Op- eration	1500 Hours of Op- eration or Ev- ery 36 Months	3000 Hours of Op- eration or Ev- ery 36 Months	4500 Hours of Op- eration or Ev- ery 36 Months	6000 Hours of Op- eration or Ev- ery 72 Mon- ths	8000 Hours of Op- eration or Ev- ery 36 Mon- ths	
Check Electrical Wiring and Connections									•
Check Air Compressors (If Equipped)									•
Check Refrigerant (A/C) Compressor (If Equipped)									•
Replace Aftertreatment DEF Dosing System Coolant Filter									•
Clean and/or Replace DEF Tank Inlet Screen									•

^aDuring the initial operation of a new or rebuilt engine with Break-In Plus, change the oil and filter between a minimum of 100 hours and a maximum of up to 500 hours.

^bService intervals depend on sulfur content of the diesel fuel, oil pan capacity, and the oil and filter used. (See Diesel Engine Oil and Filter Service Intervals in the Fuels, Lubricants, and Coolants Section.)

^cActual service should take place when the dash indicator light comes on or as indicated by the diagnostic gauge.

KP41357,000001C -19-17DEC19-2/2

Lubrication & Maintenance — Daily

Daily Prestarting Checks

Check the following items BEFORE STARTING THE ENGINE for the first time each day:

- Check engine oil level on dipstick. Fill cap/dipstick may be located on left or right side, depending on application. Add as required, using seasonal viscosity grade oil. (See [Diesel Engine Oil — Interim Tier 4, Final Tier 4, Stage IIIB, and Stage IV](#) in the Fuels, Lubricants, and Coolants Section for oil specifications.)

NOTE: Wipe all fittings, caps, and plugs before performing any maintenance to reduce the chance of system contamination.

- Check the coolant level when engine is cold. Fill radiator or surge tank with proper coolant if level is low. (See [Adding Coolant](#) in the Service As Required Section.) Check overall cooling system for leaks.
- Check radiator for leaks and trash buildup.

NOTE: It is normal for a small amount of coolant to weep from the coolant pump weep hole, especially as the engine cools down and parts contract. If enough coolant weeps from the engine where coolant drips from the engine, this

may indicate the need to replace the coolant pump seal. Contact your engine distributor or servicing dealer for repairs.

- Check fan, alternator, and accessory drive belts for cracks, breaks or other damage.
- Loosen water drain valve on each fuel filter all the way so that the valve opens to drain water and debris as needed. Retighten valves securely.

NOTE: Any water in fuel is drained into the bottom of the fuel filters. The operator is signaled by an amber indicator on the instrument panel. To service, see [Drain Water From Fuel Filters](#) in the Service As Required Section.

- Squeeze the automatic dust unloader valve (if equipped) on air cleaner assembly to clear away any dust buildup.
- Check air intake restriction indicator gauge and service air cleaner as required (if equipped).
- Check air intake system hoses and connections for cracks and loose clamps.
- Inspect the engine compartment. Look for fluid leaks, worn fan and accessory drive belts, loose connections, and trash buildup. Remove trash buildup and have repairs made as needed.

RK80614,000023 -19-05FEB14-1/1

Lubrication & Maintenance — 500 Hours/12 Months

Servicing Fire Extinguisher

A fire extinguisher (A) is available from the authorized servicing dealer or engine distributor.

Read and follow the instructions which are packaged with it. The extinguisher should be inspected at least every 500 hours of engine operation or every 12 months. Once extinguisher is operated, no matter how long, it must be recharged. Keep record of inspections on the tag which comes with the extinguisher instruction booklet.

A—Fire Extinguisher



Fire Extinguisher

RK80614,0000024 -19-11AUG21-1/1

RW4918 —UN—15DEC88

Servicing Battery

CAUTION: Battery gas can explode. Keep sparks and flames away from batteries. Use a flashlight to check battery electrolyte level.

Never check battery charge by placing a metal object across the posts. Use a voltmeter or hydrometer.

Always remove grounded **NEGATIVE (—)** battery clamp first and replace it last.

WARNING: Battery posts, terminals, and related accessories contain lead and lead compounds, chemicals known to the State of California to cause cancer and reproductive harm. **Wash hands after handling.**

IMPORTANT: Wear personal Protective Equipment while doing any type of Battery check or replacement.

1. On regular batteries, check electrolyte level. Fill each cell to bottom of filler neck with distilled water.

NOTE: Low-maintenance or maintenance-free batteries should require little additional service. However, electrolyte level can be checked by cutting the center section of decal on dash-line, and removing cell plugs. Fill each cell to bottom of filler neck with distilled water.

2. Keep batteries clean by wiping them with a damp cloth. Keep all connections clean and tight. Remove



Exploding Battery

any corrosion, and wash terminals with a solution of 1 part baking soda and 4 parts water. Tighten all connections securely.

NOTE: Coat battery terminals and connectors with a mixture of petroleum jelly and baking soda to retard corrosion.

3. Keep battery fully charged, especially during cold weather. If a battery charger is used, turn off charger before connecting charger to battery(ies). Attach **POSITIVE (+)** battery charger lead to **POSITIVE (+)** battery post. Then attach **NEGATIVE (—)** battery charger lead to a good ground.

Continued on next page

ZE59858,0000016 -19-11SEP19-1/2

TS204 —UN—15APR13

⚠ CAUTION: Sulfuric acid in battery electrolyte is poisonous. It is strong enough to burn skin, eat holes in clothing, and cause blindness if splashed into eyes.

Avoid the hazard by:

1. Filling batteries in a well-ventilated area.
2. Wearing eye protection and rubber gloves.
3. Avoiding breathing fumes when electrolyte is added.
4. Avoiding spilling or dripping electrolyte.
5. Using proper jump start procedure.

If you spill acid on yourself:

1. Flush your skin with water.
2. Apply baking soda or lime to help neutralize the acid.
3. Flush your eyes with water for 10—15 minutes. Get medical attention immediately.

If acid is swallowed:

1. Drink large amounts of water or milk.
2. Then drink milk of magnesia, beaten eggs, or vegetable oil.
3. Get medical attention immediately.

In freezing weather, run engine at least 30 minutes to ensure thorough mixing after adding water to battery.

Replacement battery(ies) must meet or exceed the following recommended capacities¹ at -18 °C (0 °F):

Specification

12-Volt System—Minimum Battery Capacity—Cold Cranking	
Amps.....	640 Minimum
Reserve Capacity (Minutes).....	285 Minimum

¹ Total recommended capacity based on batteries connected in series or parallel.

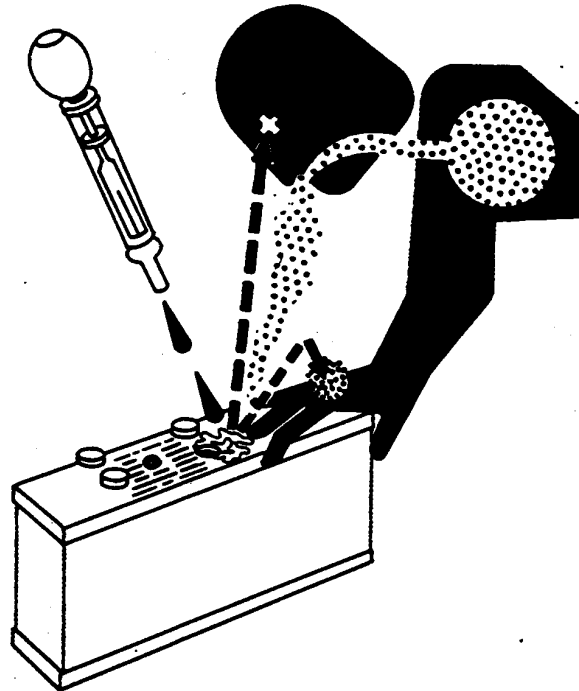

Sulfuric Acid

24-Volt System—Minimum Battery Capacity—Cold Cranking	
Amps.....	570 Minimum
Reserve Capacity (Minutes).....	275 Minimum

TS203—UN—23AUG88

ZE59858,0000016 -19-11SEP19-2/2

Changing Engine Oil and Replacing Filter

IMPORTANT: Changing engine oil and filter every 500 hours or 12 months depends on the following requirements:

- Engine equipped with an oil pan that allows capacity for this extended drain interval.
- Use of premium oil John Deere Plus-50, API CJ-4, ACEA E9, or ACEA E6.
- Perform engine oil analysis to determine the actual extended service life of API CJ-4, ACEA E9, or ACEA E6 oils.
- Use of the approved John Deere oil filter.
- Use of Ultra Low Sulfur Diesel (ULSD) fuel with sulfur content less than 0.0015% (15 mg/kg) is required.

The oil and filter change interval is reduced if **ANY** of the above listed requirements are not followed.

NOTE: During the initial operation of a new or rebuilt engine with Break-In Plus, change the oil and filter between a minimum of 100 hours and a maximum of up to 500 hours.

NOTE: Service intervals depend on sulfur content of the diesel fuel, oil pan capacity, engine power, and the oil and filter used. For more information, see Diesel Engine Oil and Filter Service Intervals in the Fuels, Lubricants, and Coolants Section.

OILSCAN™ or OILSCAN PLUS™ is a John Deere sampling program to help you monitor machine performance and identify potential problems before they cause serious damage. OILSCAN™ and OILSCAN PLUS™ kits are available from your John Deere engine distributor or servicing dealer. Oil samples should be taken prior to the oil change. Refer to instructions provided with kit.

*OILSCAN is a trademark of Deere & Company.
OILSCAN PLUS is a trademark of Deere & Company.*

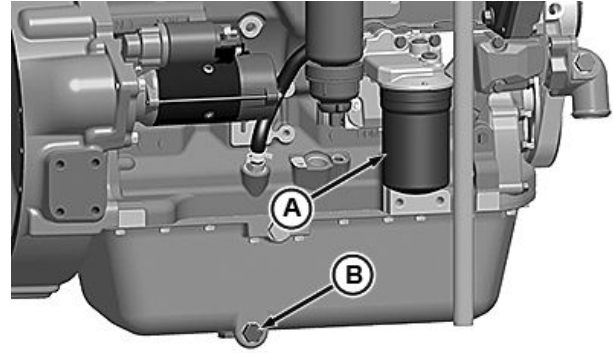

Oil Filter

A—Oil Filter

B—Oil Pan Drain Plug

IMPORTANT: Engine oil and metal surfaces of engine may be hot to the touch after shutdown. Use care to prevent burns.

1. Run engine approximately 5 minutes to warm up oil. Shut engine off.

NOTE: Drain plug location may vary, depending on the application.

2. Remove oil pan drain plug (B).
3. Drain crankcase oil from engine while warm.
4. Install oil pan drain plug with a new O-ring and tighten to specifications.

Specification

Oil Pan Drain Plug (Stamped Steel Pan)—Torque.....	40 N·m (30 lb.-ft.)
Oil Pan Drain Plug (Cast Pan)—Torque.....	48 N·m (35 lb.-ft.)

Continued on next page

ZE59858,0000017 -19-11SEP19-1/2

RG26262—UN—30JUL14

5. Remove oil filter. Discard oil filter.
6. Apply clean engine oil to the new filter at the inner (B) and outer (C) seals and to filter threads.
7. Wipe both sealing surfaces of the header (D and E) with a clean rag. Ensure notches in dust seal (F) are properly installed in the slots in the housing. Replace dust seal if damaged.

IMPORTANT: When installing filter element, HAND TIGHTEN only. A filter wrench may be used for REMOVAL ONLY. Be sure notches in dust seal (F) are properly installed in the slots in the housing.

8. Install and tighten oil filter by hand until firmly against dust seal (F). DO NOT apply an extra 3/4 to 1-1/4 turn after gasket contact, as done with standard filters.
9. Fill engine crankcase with correct John Deere engine oil through oil filler cap on either side of engine depending on engine application. (See [Diesel Engine Oil — Interim Tier 4, Final Tier 4, Stage IIIB, and Stage IV](#) in Fuels, Lubricants, and Coolant Section for determining correct engine oil.)

To determine the correct oil fill quantity for your engine, see [Engine Crankcase Oil Fill Quantities](#) in the Specifications Section of this manual.

NOTE: Crankcase oil capacity may vary slightly. ALWAYS fill crankcase within crosshatch marks on dipstick. DO NOT overfill.

10. Start engine and run to check for possible leaks.
11. Stop engine and check oil level after 10 minutes. Oil level reading should be within crosshatch marks on dipstick.



Oil Filter Seals

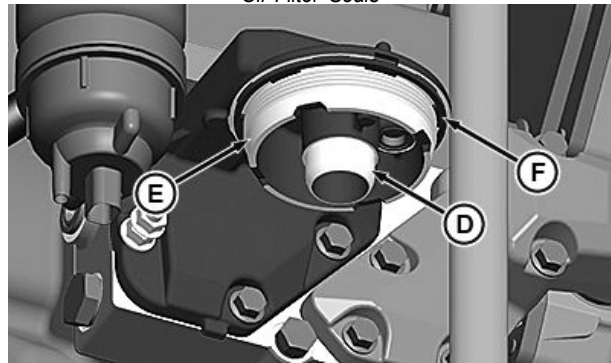

Oil Filter Header

B—Inner Seal
 C—Outer Seal
 D—Sealing Surface On Header
 E—Sealing Surface On Header
 F—Dust Seal

RG26263 —UN—30JUL14

RG26264 —UN—30JUL14

ZE59858,0000017 -19-11SEP19-2/2

Visually Inspecting Coolant Pump

NOTE: Cooling pump drive pulley is removed for clarity purposes.

1. Coolant leakage indicates a damaged front seal. Inspect weep hole (A) for coolant leakage.
2. Replace complete coolant pump assembly if leakage is detected. A slight weeping of coolant is normal. If enough coolant leaks from the weep hole that it drips from the engine, the coolant pump assembly should be replaced. Individual repair parts are not available.

A—Weep Hole



RG26265 —UN—30JUL14

ZE59858,0000018 -19-30JUL14-1/1

Checking Open Crankcase Vent (OCV)

Inspect OCV hoses (A, B, and C) for worn, cracked, leaking, or bulging.

Check hose clamps (D, E, and F) for good clamp tension.

Replace any worn or damaged parts.

- | | |
|-------------------|--------------------------|
| A—OCV Inlet Hose | D—Clamp — Inlet Hose |
| B—Air Outlet Hose | E—Clamp — Oil Drain Hose |
| C—Oil Drain Hose | F—Clamp — Outlet Hose |

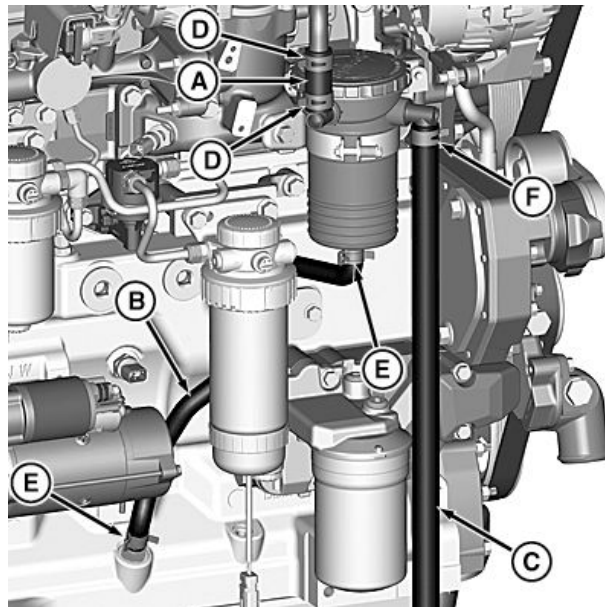

RG20672 — UN — 1JUL11

ZE59858,0000019 -19-30JUL14-1/1

Removing and Installing Fuel Filters

Engines are equipped with dual fuel filters: a primary filter with water bowl, and a final filter. Both filters are replaced at the same 500 hour or 12 months interval.

⚠ CAUTION: Escaping fluid under pressure can penetrate the skin causing serious injury. Relieve pressure before disconnecting fuel or other lines. Tighten all connections before applying pressure. Keep hands and body away from pinholes and nozzles which eject fluids under high pressure. To search for leaks use a piece of cardboard or paper. Do not use your hand.

If any fluid is injected into the skin, it must be surgically removed within a few hours by a doctor familiar with this type injury or gangrene may result. Doctors unfamiliar with this type of injury may call the Deere & Company Medical Department in Moline, Illinois, or other knowledgeable medical source.

IMPORTANT: Replace fuel filter elements anytime audible alarm sounds and diagnostic trouble

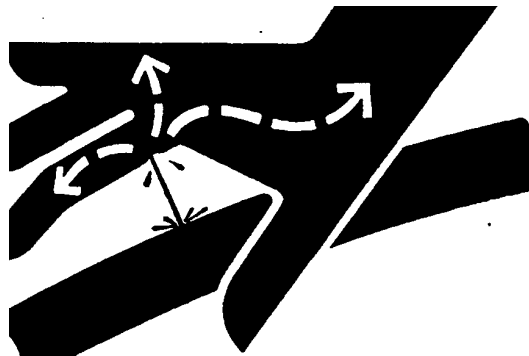

High-Pressure Fluids

codes (DTCs) indicate plugged fuel filters (low fuel pressure). If no alarm sounds during the 12 month or after 500 hours service interval, replace elements.

X9811 — UN — 23AUG88

Continued on next page

ZE59858,000001A -19-29JAN21-1/3

Remove and Install Primary Fuel Filter Element

IMPORTANT: Prevent damage to filter, bowl, and sensor threads. No tools are required to change the fuel filter. If filter retaining nut is too tight to remove by hand, use a suitable tool to loosen. When reinstalling, only tighten by hand.

NOTE: Both primary and secondary filters must be replaced at the same time.

NOTE: For applications other than OEM, refer to operator's manual for proper servicing, hourly replacement intervals, and filter locations.

1. Thoroughly clean primary filter header (A) and surrounding area to prevent dirt and debris from entering fuel system.
2. Disconnect water-in-fuel sensor connector (G).
3. Connect a hose to filter drain valve (H) on bottom of primary fuel filter element (D) and drain all fuel from filter canister.
4. Grip and loosen fuel filter retaining nut (C). **DO NOT** loosen by gripping water separator bowl (F).
5. Remove primary fuel filter element (D).
6. Remove the water separator bowl (F). Discard rubber washers (E).
7. Place new rubber washers (E) on both side of the water separator bowl (F). Lubricate with clean diesel fuel.

IMPORTANT: Prevent damage to threads. DO NOT tighten water-in-fuel sensor or water separator bowl past contact plus 1/4 turn.

8. Install water-in-fuel sensor to water separator bowl (F). Tighten to contact plus 1/4 turn.

IMPORTANT: Prevent damage to threads. DO NOT tighten water-in-fuel sensor or water separator bowl past contact plus 1/4 turn.

9. Install water separator bowl (F) to primary fuel filter element (D). Tighten to contact plus 1/4 turn.

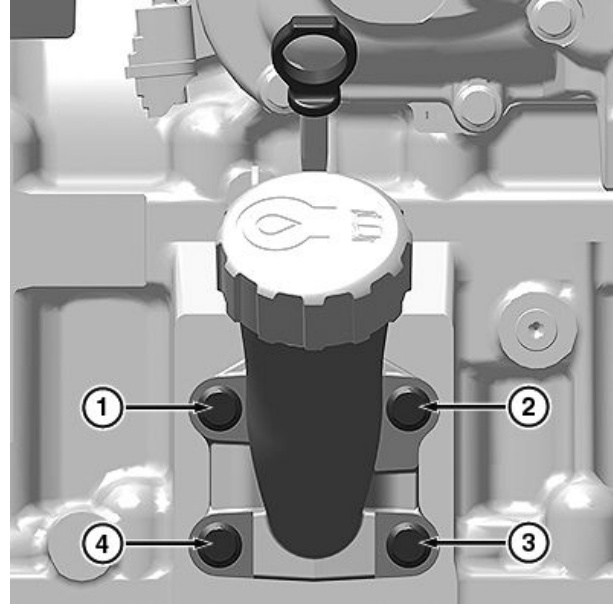

Primary Fuel Filter Element - Exploded View

- | | |
|-------------------------------|----------------------------------|
| A—Primary Fuel Filter Header | E—Rubber Washer (2 used) |
| B—O-rings (3 used) | F—Water Separator Bowl |
| C—Filter Retaining Nut | G—Water-In-Fuel Sensor Connector |
| D—Primary Fuel Filter Element | H—Drain Valve |

10. Apply a thin film of fuel on filter element O-rings (B).

IMPORTANT: Prevent fuel system damage. Do not fill the new filter with fuel before installing. Contamination to the fuel system will occur.

11. Install new primary fuel filter (D) to primary fuel filter header (A). Tighten only primary fuel filter element (D) using filter retaining nut (C). Tighten by hand to full contact until filter retaining nut (C) hits stop.
12. Reconnect water-in-fuel sensor connector (G).

Continued on next page

ZE59858,000001A -19-29JAN21-2/3

RG33402—UN—21JUN21

Remove and Install Secondary Fuel Filter Element

NOTE: For applications other than OEM, refer to the application operator's manual for proper servicing, hourly replacement intervals, and filter locations.

1. Thoroughly clean filter header (B) and surrounding area to prevent dirt and debris from entering fuel system.
2. Loosen and remove fuel filter element (A).
3. Apply a thin film of fuel on packing.

IMPORTANT: Do not fill the new filter with fuel before installing. This could possibly contaminate the fuel system with unfiltered fuel.

4. Install new filter and tighten until the top portion of the filter contacts the filter header assembly.

NOTE: For electronic fuel pump: To prime the fuel system before starting engine. Turn ignition key to ON for 60 seconds.

NOTE: For mechanical fuel pump: To prime the fuel system before starting engine. Open bleed vent

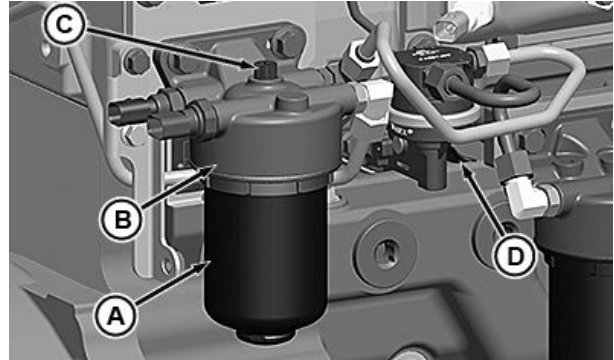

Replace Secondary Fuel Filter Element

- | | |
|---------------------------------|--------------------|
| A—Secondary Fuel Filter Element | C—Bleed Vent Screw |
| B—Secondary Fuel Filter Header | D—Primer Lever |

screw, pump primer lever until fuel flows out of bleed vent screw, then tighten bleed vent screw securely.

ZE59858,000001A -19-29JAN21-3/3

RG26322—UN—13AUG14

Checking Belt Wear

NOTE: While belt is loosened, inspect pulleys and bearings. Rotate and feel for hard turning or any unusual sounds. If pulleys or bearings need replacement, see your John Deere dealer.

The belt tensioner is designed to operate within the limit of arm movement provided by the cast stops when correct belt length and geometry are used.

Visually inspect cast stops on belt tensioner (A) assembly.

If the tensioner stop on swing arm is hitting the fixed stop, check mounting brackets (alternator, belt tensioner, idler pulley, etc.) and the belt length.

- Verify belt grooves mate correctly with all pulleys
- Inspect for excessive cracks
- Inspect for glazing
- Inspect for tears or cuts

Replace belt as needed based on wear and belt condition. Use correct belt routing during installation (see [Replacing Fan Belt](#) in the Service As Required Section).

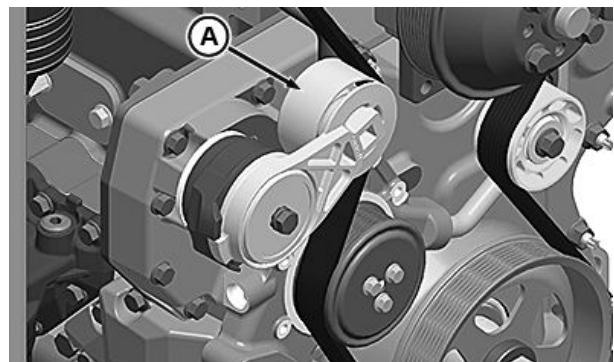

A—Belt Tensioner Assembly

ZE59858,000001B -19-30JUL14-1/1

RG26255—UN—30JUL14

Checking Tensioner Spring Tension

A belt tension gauge will not give an accurate measure of the belt tension when automatic spring tensioner is used. Measure tensioner spring tension using a torque wrench and procedure outlined below:

1. Release tension on belt using a long-handled 1/2 inch drive tool in tensioner arm. Remove belt from pulleys.
2. Release tension on tensioner arm and remove drive tool.
3. Put a mark (A) on swing arm of tensioner as shown.
4. Measure 21 mm (0.83 in.) from mark (A) and put a mark (B) on tensioner mounting base.

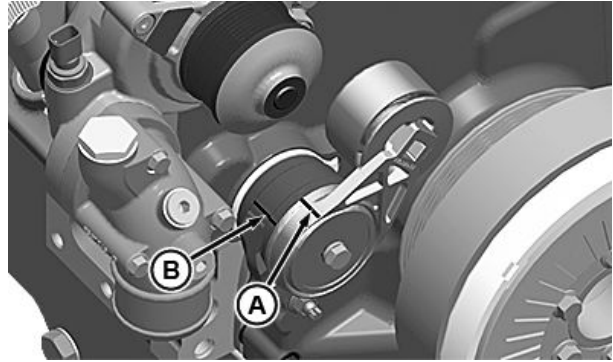

Checking Belt Tension Spring Tension

A—Mark

B—Mark

RG24039 —UN—07AUG13

ZE59858,000001C -19-29JUL14-1/2

5. Rotate the swing arm using a torque wrench until marks (A and B) are aligned.
6. Record torque wrench measurement and compare with specification below. Replace tensioner assembly as required.

Specification

Spring—Tension..... 18—22 N·m (13—16 lb.-ft.)

A—Mark

B—Mark

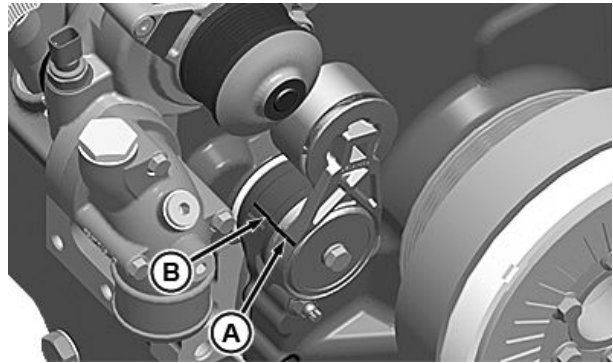

Checking Belt Tensioner Spring Tension

RG24040 —UN—07AUG13

ZE59858,000001C -19-29JUL14-2/2

Checking Cooling System

CAUTION: Explosive release of fluids from pressurized cooling system can cause serious burns.

Shut off engine. Only remove filler cap when cool enough to touch with bare hands. Slowly loosen cap to first stop to relieve pressure before removing completely.

IMPORTANT: Air must be expelled from cooling system when system is refilled. Loosen temperature sending unit fitting at rear of cylinder head or plug in thermostat housing to allow air to escape when filling system. Retighten fitting or plug when all the air has been expelled. Cooling system must be free of air by time engine coolant temperature reaches 80 °C (176 °F) or damage to EGR cooler (if equipped) may result.



High Pressure Fluids

1. Check entire cooling system for leaks. Tighten all clamps securely.
2. Thoroughly inspect all cooling system hoses for hard, flimsy, or cracked conditions. Replace hoses if any of the above conditions are found.

TS281 —UN—15APR13

RK80614,000002D -19-11JUL13-1/1

Pressure Testing Cooling System

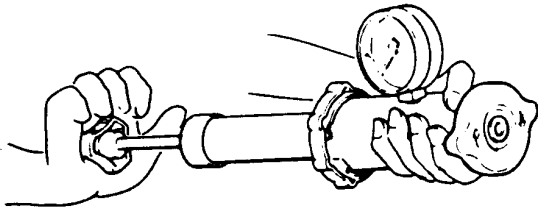

Test Radiator Cap

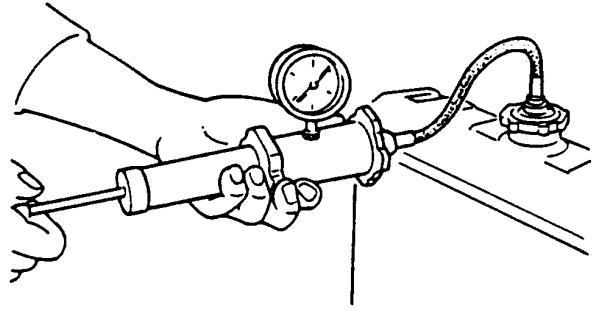

Test Cooling System

CAUTION: Explosive release of fluids from pressurized cooling system can cause serious burns.

Shut off engine. Only remove filler cap when cool enough to touch with bare hands. To relieve pressure before completely removing, slowly remove pressure cap and allow pressure to relieve before completely removing cap.

Test Radiator Cap

1. Remove radiator cap and attach to D05104ST Tester, or similar, as shown.
2. Pressurize cap to following specifications.¹ Gauge should hold pressure for 10 seconds within the normal range if cap is acceptable.

Specification

Radiator Cap—Maximum Pressure..... 124 kPa (1.24 bar) (18 psi)

If gauge does not hold pressure, replace radiator cap.

3. Remove the cap from gauge, turn it 180°, and retest cap. This verifies that the first measurement was accurate.

Test Cooling System for Leaks

NOTE: Engine should be warmed up to test overall cooling system for leaks.

¹Test pressures recommended are for all Deere OEM cooling systems. On specific vehicle applications, test cooling system and pressure cap according to the recommended pressure for that vehicle.

1. Allow engine to cool, then carefully remove radiator cap.
2. Fill radiator with coolant to the normal operating level.
3. Connect gauge and adapter to radiator filler neck, or expansion tank. Pressurize cooling system to the following specifications¹.
4. With pressure applied, check all cooling system hose connections, radiator, and overall engine for leaks.

Specification

Cooling System—Maximum Pressure..... 124 kPa (1.24 bar) (18 psi)

If leakage is detected, correct as necessary and pressure test system again.

If no leakage is detected, but the gauge indicated a drop in pressure, coolant may be leaking internally within the system or at the block-to-head gasket. Have your servicing dealer or distributor correct this problem immediately.

Checking and Adjusting Engine Speeds

Use tachometer on the diagnostic gauge screen (A) to verify engine speeds. See Engine Power and Speed Rating Specifications in Section 75 for engine speed specifications. If engine speed adjustment is required, see the authorized servicing dealer or engine distributor.

A—Diagnostic Gauge Screen

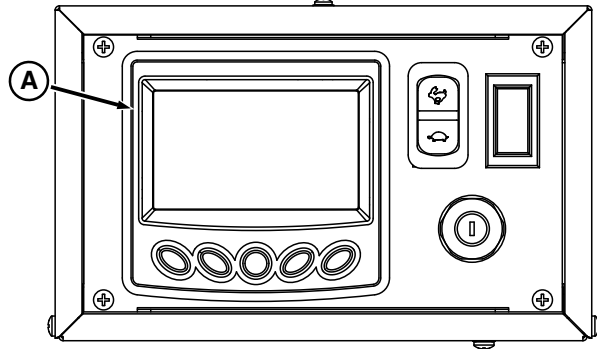

DG14 Diagnostic Gauge

RK80614,0000030 -19-20AUG21-1/1

RG22413 —UN—27AUG13

Checking Engine Mounts

Engine mounting is the responsibility of the Original Equipment Manufacturer. Follow manufacturer's guidelines for mounting specifications.

IMPORTANT: Avoid possible cap screw or thread damage. Use only Class 10.9, Grade SAE 8, or higher grade of hardware for engine mounting.

1. Check the engine mounting brackets, vibration isolators, and mounting bolts on support frame and engine block for tightness. Tighten as necessary.
2. Inspect overall condition of vibration isolators, if equipped. Replace isolators, as necessary, if rubber has deteriorated or mounts have collapsed.

RK80614,0000031 -19-20AUG21-1/1

Checking Engine Ground Connection

Check engine ground connection to be sure that it is secure and clean. This will prevent electrical arcing which can damage engine.

- Verify engine to frame ground.
- Verify battery ground to frame.
- Verify engine control unit to ground (remote mount).

RK80614,0000033 -19-26AUG21-1/1

Lubrication & Maintenance — 1500 Hours

Changing Open Crankcase Ventilation (OCV) Filter

Service checks of the OCV include checking and/or replacement of worn, cracked, leaking, or bulging hoses and for good clamp tension on all hose ends.

Expectation for minimal service interval will be at least 1500 hours or when the service indicator light comes on or as indicated by the diagnostic gauge.

NOTE: Depending on the application, there are multiple design configurations for OCV filter. Please refer the appropriate component technical manual for installation and removal procedure.

1. Remove cap (A).
2. Remove OCV filter from canister.
Discard old OCV filter.
3. Install new OCV filter.

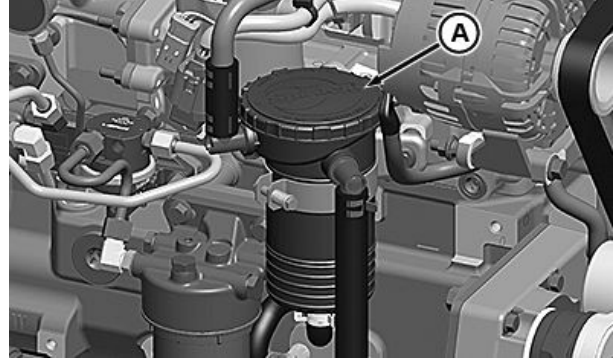

Changing OCV

A—Cap

4. Install cap (A).

ZE59858,000001E -19-27MAY22-1/1

RG26260 —UN—30JUL14

Lubrication & Maintenance — 1500 Hours/36 Months

Access DEF Tank Header

See your application manual for information on accessing the DEF tank header.

EJ20264,00002E7 -19-20NOV17-1/1

Replace Diesel Exhaust Fluid (DEF) Tank Header Suction Screen

DEF Tank Header Identification

NOTE: Accessing DEF tank header may require removing additional covers or components. See Access DEF Tank Header for location information.

Type A DEF tank header has one wiring harness connection (A). Type B DEF tank header has two wiring harness connections (B). Refer to the procedure that is applicable to your DEF tank header.

A—Type A DEF Tank Header
(one electrical connection)

B—Type B DEF Tank Header
(two electrical connections)

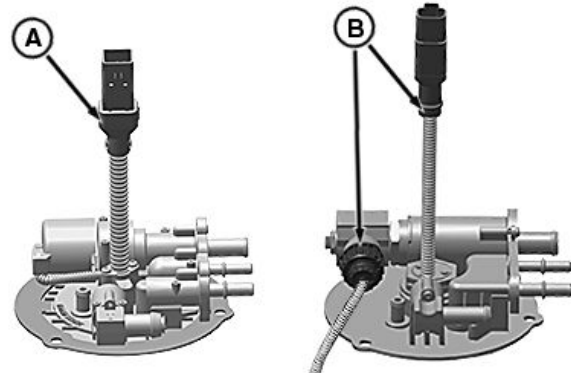

DEF Tank Header Identification

Continued on next page

DX,DEF,REPL,THSCREEN -19-08DEC17-1/12

RG29623 —UN—18JUL17

Replace Type A DEF Tank Header Suction Screen

CAUTION: Avoid contact with eyes. In case of contact, immediately flush eyes with large amounts of water for a minimum of 15 minutes. Reference the Materials Safety Data Sheet (MSDS) for additional information.

IMPORTANT: If DEF is spilled or contacts any surface other than the storage tank, immediately clean the surface with clear water. DEF is corrosive to painted and unpainted metallic surfaces and can distort some plastic and rubber components.

Spilled DEF, if left to dry or if only wiped away with a cloth, leaves a white residue. Improperly cleaned DEF spill can interfere with diagnosis of Selective Catalytic Reduction (SCR) system leakage problems.

NOTE: DEF tank header suction screen must be replaced every 1500 hours or 36 months, whichever occurs first. The DEF dosing unit filter must be replaced at the same time.

1. Clear all debris from area around DEF tank header.

CAUTION: Explosive release of fluids from pressurized cooling system can cause serious burns. Before disconnecting coolant hoses, wait until engine coolant is cool enough to touch the radiator or surge tank cap with bare hands. Slowly loosen radiator or surge tank cap to first stop to relieve pressure.

IMPORTANT: Cap and plug all lines and fittings to prevent contamination. Coolant in DEF

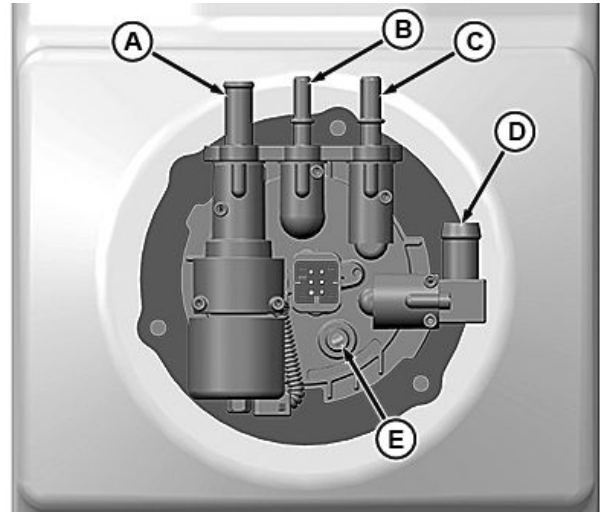

DEF Tank Header Fittings

- | | |
|---------------------------|-------------------------|
| A—Coolant Outlet Fitting | D—Coolant Inlet Fitting |
| B—DEF Return Line Fitting | E—Vent Line Fitting |
| C—DEF Supply Line Fitting | |

causes Selective Catalytic Reduction (SCR) system performance issues.

2. Disconnect coolant hoses from fittings (A and D).
3. Disconnect DEF return and supply lines from fittings (B and C).
4. Disconnect DEF tank header electrical connector.
5. Remove vent hose from fitting (E).

Continued on next page

DX,DEF,REPL,THSCREEN -19-08DEC17-2/12

RG28624 —JUN—19JUL17

6. Remove cap screws from DEF tank header locking ring (A).
7. Remove DEF tank header (C) from tank.
8. Remove O-rings (B) and inspect for damage.
9. Replace O-rings (B) if necessary.

A—DEF Tank Header Locking Ring
 B—O-Ring (2 used)
 C—DEF Tank Header

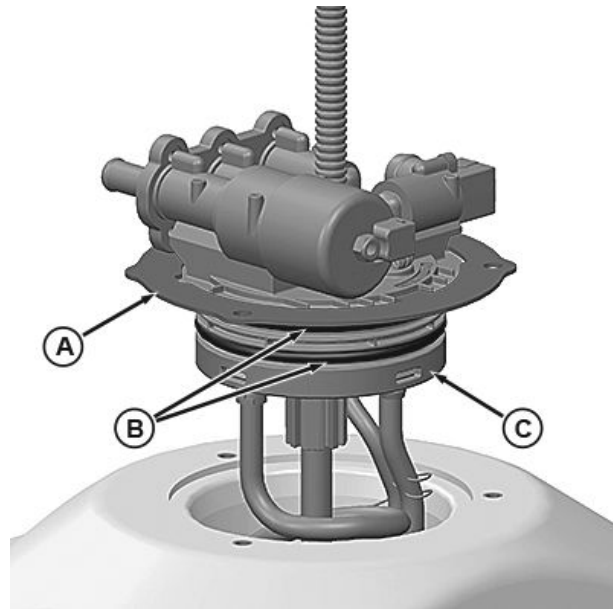

DEF Tank Header

DX,DEF,REPL,THSCREEN -19-08DEC17-3/12

RG29625 —UN—25JUL17

10. Remove screw (A) that secures suction screen (B) to suction tube (C).
11. Remove suction screen (B).
12. Install suction screen (B) to suction tube (C).
13. Install screw (A) and tighten to specification.

Specification

DEF Suction Screen
 Screw—Torque.....1 N·m
 (11 lb-in)

A—Screw
 B—Suction Screen
 C—Suction Tube

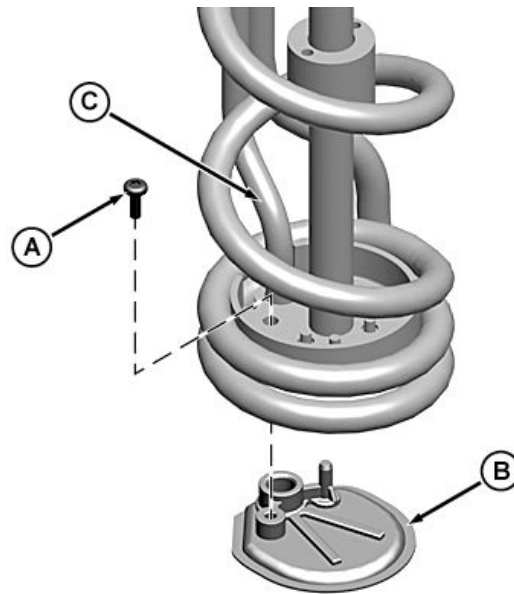

DEF Suction Screen

Continued on next page

DX,DEF,REPL,THSCREEN -19-08DEC17-4/12

RG23672 —UN—01JUL13

14. Lubricate O-rings (B) with clean DEF.
15. Insert DEF header into tank and align holes on locking ring (A) with holes in tank.

A—DEF Tank Header Locking Ring C—DEF Tank Header
 B—O-Ring (2 used)

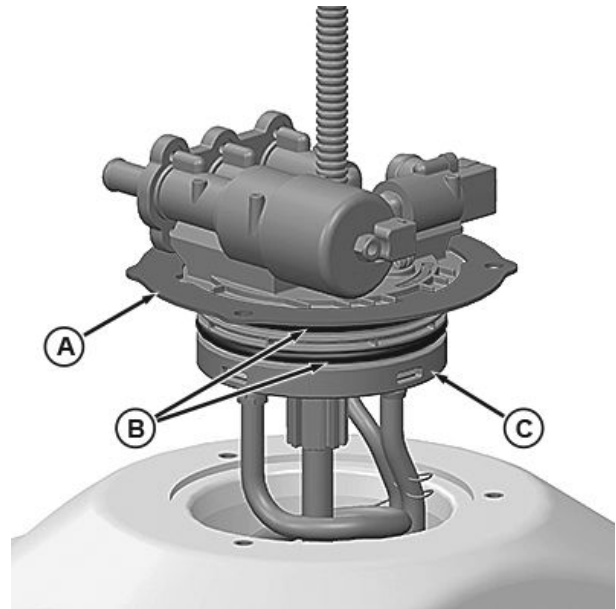

DEF Tank Header

DX,DEF,REPL,THSCREEN -19-08DEC17-5/12

RG29625—UN—25JUL17

IMPORTANT: Prevent DEF leak, header, and lock ring damage. Ensure that alignment notches on the locking ring are properly aligned with plastic tabs on the header.

16. Install stainless steel cap screws into mounting holes and tighten to specification.

Specification

DEF Tank Header M6
 Cap Screw—Torque.....9 N·m
 (80 lb·in)

A—Alignment Notch (2 used)

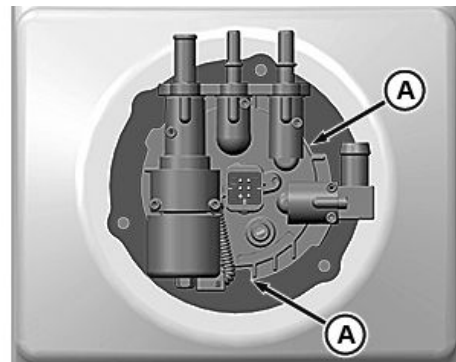

Alignment Notches

Continued on next page

DX,DEF,REPL,THSCREEN -19-08DEC17-6/12

RG25370—UN—03APR14

17. Connect 9.5 mm (3/8 in) vent hose to fitting (E).
18. Connect 16 mm (5/8 in) coolant hose to coolant inlet fitting (D).
19. Connect 13 mm (1/2 in) coolant hose to coolant outlet fitting (A).

IMPORTANT: Push DEF line onto fitting until you hear a “click”, then lightly pull back to ensure that it is connected and locked in place.

NOTE: DEF supply and return lines have unique sized fittings.

20. Connect DEF return and supply lines to fittings (B and C).
21. Connect DEF tank header electrical connector.

A—Coolant Outlet Fitting	D—Coolant Inlet Fitting
B—DEF Return Line Fitting	E—Vent Line Fitting
C—DEF Supply Line Fitting	

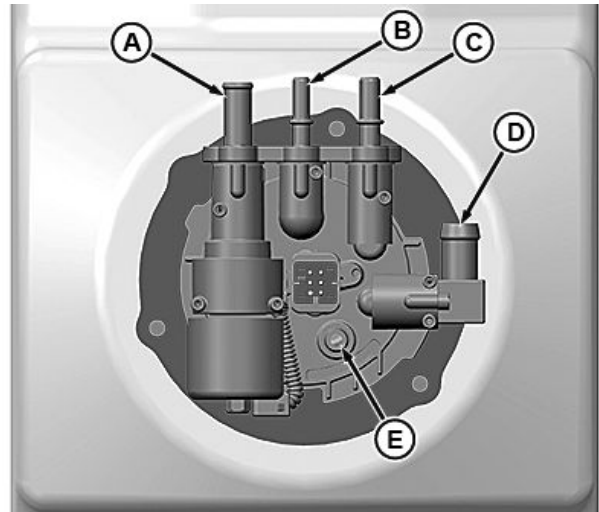

DEF Tank Header Fittings

RG29624 —UN—19.JUL.17

Continued on next page

DX,DEF,REPL,THSCREEN -19-08DEC17-7/12

Replace Type B DEF Tank Header Suction Screen

CAUTION: Avoid contact with eyes. In case of contact, immediately flush eyes with large amounts of water for a minimum of 15 minutes. Reference the Materials Safety Data Sheet (MSDS) for additional information.

IMPORTANT: If DEF is spilled or contacts any surface other than the storage tank, immediately clean the surface with clear water. DEF is corrosive to painted and unpainted metallic surfaces and can distort some plastic and rubber components.

Spilled DEF, if left to dry or if only wiped away with a cloth, leaves a white residue. Improperly cleaned DEF spill can interfere with diagnosis of Selective Catalytic Reduction (SCR) system leakage problems.

NOTE: DEF tank header suction screen must be replaced every 1500 hours or 36 months, whichever occurs first. The DEF dosing unit filter must be replaced at the same time.

1. Clear all debris from area around DEF tank header.

CAUTION: Explosive release of fluids from pressurized cooling system can cause serious burns. Before disconnecting coolant hoses, wait until engine coolant is cool enough to touch the radiator or surge tank cap with bare hands. Slowly loosen radiator or surge tank cap to first stop to relieve pressure.

IMPORTANT: Cap and plug all lines and fittings to prevent contamination. Coolant in DEF

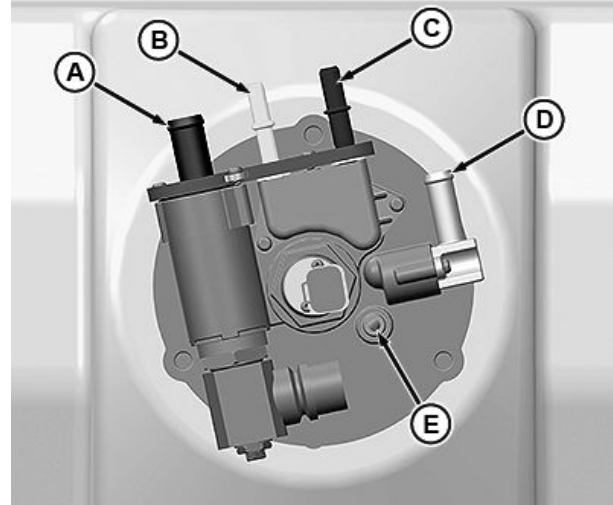

DEF Tank Header Fittings

A—Coolant Inlet Fitting D—Coolant Outlet Fitting
 B—DEF Return Line Fitting E—Vent Line Fitting
 C—DEF Supply Line Fitting

causes Selective Catalytic Reduction (SCR) system performance issues.

2. Disconnect coolant hoses from fittings (A and D).
3. Disconnect DEF return and supply lines from fittings (B and C).
4. Disconnect DEF tank header electrical connectors.
5. Remove vent hose from fitting (E).

DX,DEF,REPL,THSCREEN -19-08DEC17-8/12

6. Remove cap screws from DEF tank header mounting flange (A).
7. Remove DEF tank header (C) from tank.
8. Remove O-rings (B) and inspect for damage.
9. Replace O-rings (B) if necessary.

A—DEF Tank Header Mounting Flange C—DEF Tank Header
 B—O-Ring (2 used)

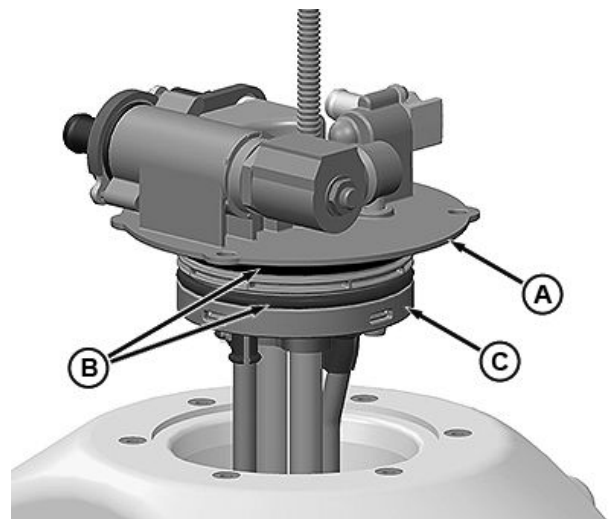

DEF Tank Header

Continued on next page

DX,DEF,REPL,THSCREEN -19-08DEC17-9/12

17. Connect 9.5 mm (3/8 in) vent hose to fitting (E).
18. Connect 16 mm (5/8 in) coolant hose to coolant inlet fitting (A).
19. Connect 13 mm (1/2 in) coolant hose to coolant outlet fitting (D).

IMPORTANT: Push DEF line onto fitting until you hear a “click”, then lightly pull back to ensure that it is connected and locked in place.

NOTE: DEF supply and return lines have unique sized fittings.

20. Connect DEF return and supply lines to fittings (B and C).
21. Connect DEF tank header electrical connectors.

A—Coolant Inlet Fitting	D—Coolant Outlet Fitting
B—DEF Return Line Fitting	E—Vent Line Fitting
C—DEF Supply Line Fitting	

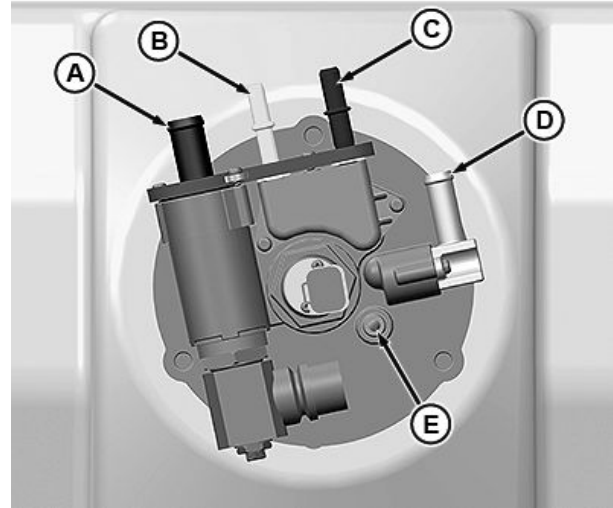

DEF Tank Header Fittings

RG29626—UN—19JUL17

DX,DEF,REPL,THSCREEN -19-08DEC17-12/12

Adjusting Valve Clearance

CAUTION: To prevent accidental starting of engine while performing valve adjustments, always disconnect **NEGATIVE (—)** battery terminal.

IMPORTANT: Valve clearance **MUST BE** checked and adjusted with engine **COLD**.

1. Remove rocker arm cover and crankcase ventilation tube.
2. Remove plastic plug (A) from engine timing/rotation hole (B) and timing pin hole (C).

IMPORTANT: Visually inspect contact surfaces of bridges, and rocker arm wear pads. Check all parts for excessive wear, breakage, or cracks. Replace parts that show visible damage.

Rocker arms that exhibit excessive valve clearance should be inspected more thoroughly to identify damaged parts.

3. Install JDG820 flywheel turning tool and JDG1571 timing pin.
4. Rotate engine with the flywheel turning tool until locking pin engages timing hole in flywheel.

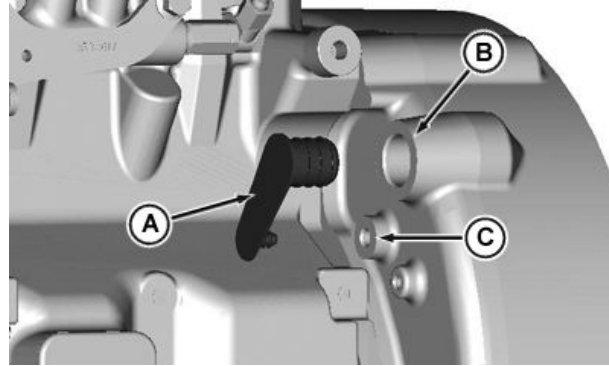

Bores to Insert Flywheel Turning Tool and Locking Pin

A—Plastic Plug C—Locking Pin Bore
B—Flywheel Turning Tool Bore

NOTE: If the rocker arms for No. 1 (front) cylinder are loose, the engine is at No. 1 top dead center.

NOTE: If the rocker arms for No. 4 (rear) cylinder are loose, the engine is at No. 4 top dead center. Rotate the engine one full revolution (360°) to No. 1 top dead center.

Continued on next page

ZE59858,000001F -19-13AUG14-1/4

RG20536—UN—03JUN11

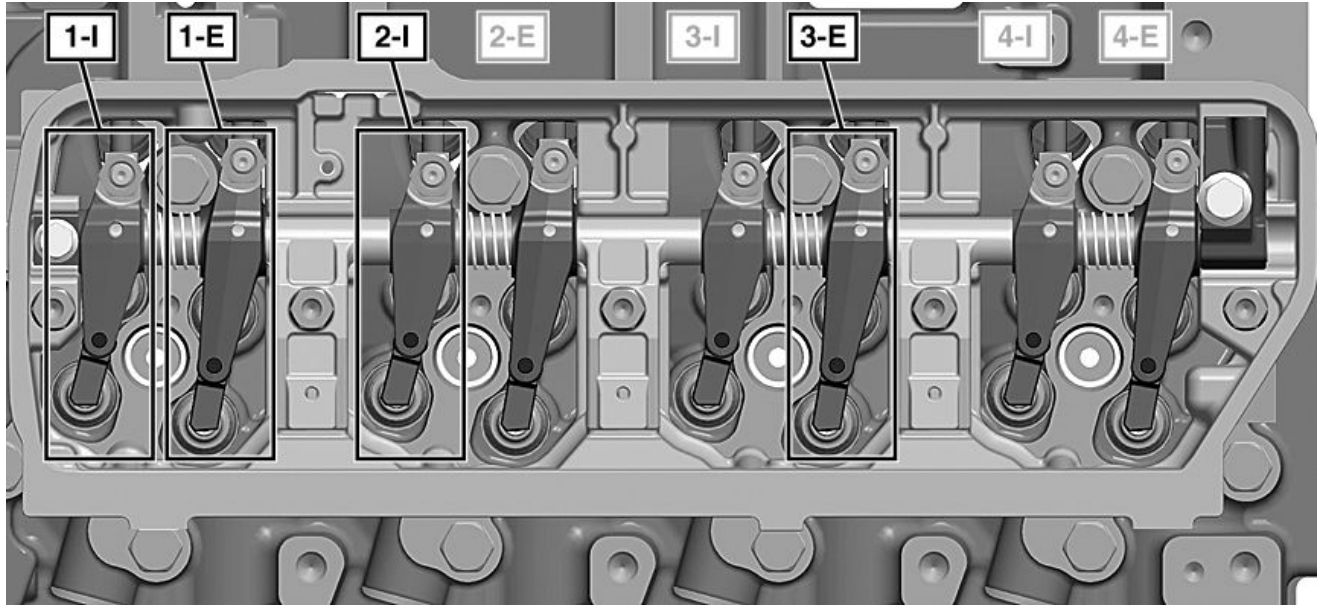

Valve Clearance Adjustment — #1 TDC

- With engine locked at “TDC” of No. 1 piston compression stroke, use a bent feeler gauge to check valve clearance on No. 1 and 3 exhaust and No. 1 and 2 intake valves. Loosen lock nut (F) on rocker arm adjusting screw. Turn adjusting screw with a 4 mm hex key until feeler gauge slips with a slight drag. Hold the adjusting screw from turning and tighten lock nut to specifications

Specification

Intake Valve Clearance (Rocker Arm-to-Valve Bridge With Engine Cold)—Clearance.....	0.46 mm (0.018 in.)
Exhaust Valve Clearance (Rocker Arm-to-Valve Bridge With Engine Cold)—Clearance.....	0.53 mm (0.021 in.)
Valve Adjusting Screw Lock Nut—Torque.....	27 N·m (20 lb.-ft.)

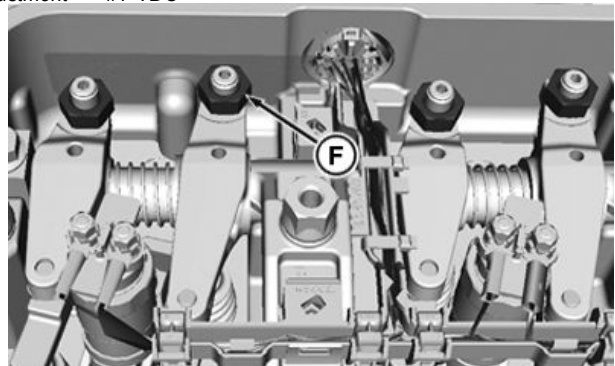

Rocker Arm Lock Nut

F— Lock Nut

Recheck clearance again after tightening lock nut.
Readjust clearance as necessary.

Continued on next page

ZE59858.000001F -19-13AUG14-2/4

RG20492—UN—24/JUN11

RG25615—UN—24/APR14

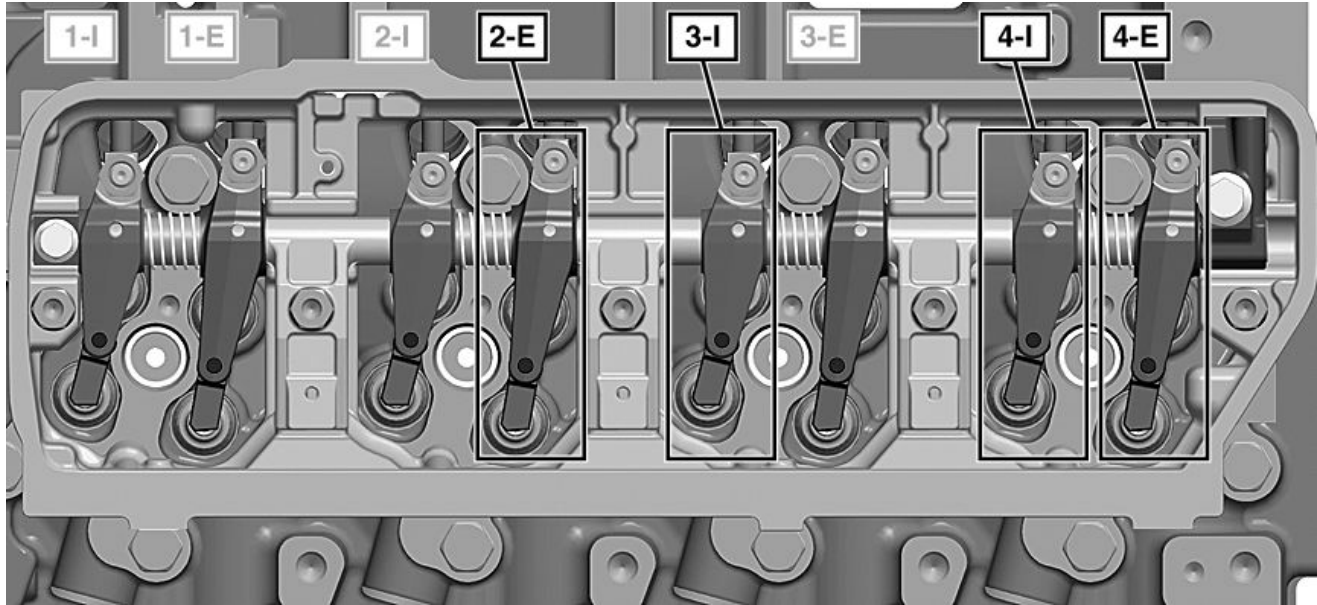

RG20493 —UN—24JUN11

Valve Clearance Adjustment — #4 TDC

6. Rotate flywheel 360° until No. 4 piston is at "TDC" of its compression stroke. Rocker arms for No. 4 piston should be loose.
7. Check and adjust valve clearance to the same specifications on for No. 2 and 4 exhaust and No. 3 and 4 intake valves.

ZE59858,000001F -19-13AUG14-3/4

8. Install rocker arm cover gasket.

IMPORTANT: When reinstalling rocker arm cover, inspect gasket for damage prior to reusing.

9. Tighten cap screws to specifications, in the sequence shown.

Specification

Rocker Arm Cover Cap
Screws—Torque.....11 N·m (97 lb.-in.)

10. Install vent tube to rocker arm cover.



RG25069 —UN—14FEB14

Rocker Arm Cap Screws Tightening Sequence

ZE59858,000001F -19-13AUG14-4/4

Testing Glow Plugs for Continuity

CAUTION: To prevent accidental starting of engine while performing this test, always disconnect **NEGATIVE (—)** battery terminal.

1. Remove glow plug wiring harness connector (C).
2. Using a multimeter, check resistance from terminal (B) to the outer body of glow plug (A).
If resistance is more than 10 Ohms, the glow plug is damaged and must be replaced.
3. If needed, install new glow plugs and torque to specifications.

Specification

Glow Plug—Torque..... 15 N·m (133 lb.-in.)

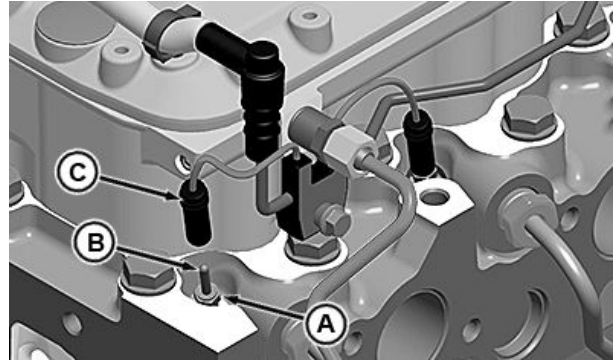

Check Glow Plug

A—Glow Plug
B—Terminal

C—Harness Connector

RG26311—UN—13AUG14

ZE59858,0000020 -19-13AUG14-1/1

Lubrication & Maintenance — 4500 Hours/36 Months

Access DEF Dosing Unit

See your application manual for information on accessing the DEF dosing unit.

ZE59858,000008D -19-20NOV17-1/1

Change Diesel Exhaust Fluid (DEF) Dosing Unit Filter

CAUTION: Avoid contact with eyes. In case of contact, immediately flush eyes with large amounts of water for a minimum of 15 minutes. Reference the Materials Safety Data Sheet (MSDS) for additional information.

IMPORTANT: If DEF is spilled or contacts any surface other than the storage tank, immediately clean the surface with clear water. DEF is corrosive to painted and unpainted metallic surfaces and can distort some plastic and rubber components.

Spilled DEF, if left to dry or if only wiped away with a cloth, leaves a white residue. Improperly cleaned DEF spill can interfere with diagnosis of Selective Catalytic Reduction (SCR) system leakage problems.

NOTE: See your John Deere equipment technical manual or OEM manufacturer's technical manual for DEF dosing unit filter location.

IMPORTANT: Avoid system and filter damage. Ensure that DEF system is not frozen before changing filter. If system is frozen, operate engine until system has thawed completely.

1. Remove DEF dosing unit filter cover (A).
2. Remove and discard DEF dosing unit filter equalizing element (B).

NOTE: DEF dosing unit filter tool (C) is supplied with replacement filter.

3. Insert "Black" end of DEF dosing unit filter tool (C) into DEF dosing unit filter (D) until CLICK is felt or heard indicating DEF dosing unit filter tool is fully engaged.

NOTE: A tool such as a screwdriver can be inserted into DEF dosing unit filter tool slot to assist removal.

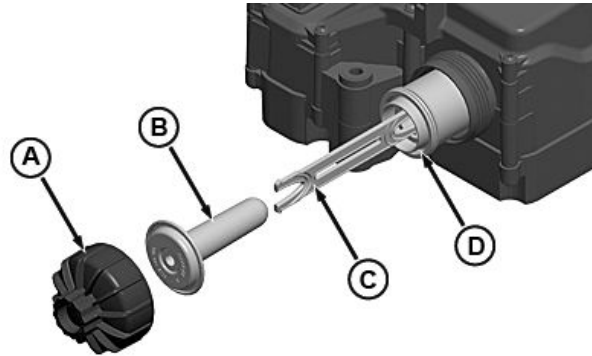

DEF Dosing Unit Filter

- A—DEF Dosing Unit Filter Cover
B—DEF Dosing Unit Filter Equalizing Element
C—DEF Dosing Unit Filter Tool (supplied with new filter)
D—DEF Dosing Unit Filter

4. Pull DEF dosing unit filter tool and DEF dosing unit filter from DEF dosing unit. Discard DEF dosing unit filter and DEF dosing unit filter tool.
5. Clean DEF dosing unit threads and mating surfaces with distilled water.
6. Lubricate DEF filter O-rings with clean DEF. Carefully insert DEF dosing unit filter into DEF dosing unit.
7. Install new DEF dosing unit filter equalizing element into DEF dosing unit filter.
8. Install DEF dosing unit filter cover and tighten to specification.

Specification

DEF Dosing Unit Filter	
Cover—Torque.....	23 N·m (204 lb·in)

DX,DEF,CHANGE,FILT -19-31OCT19-1/1

RG22534—UN—21MAR13

Lubrication & Maintenance — 6000 Hours/72 Months

Flushing and Refilling Cooling System

⚠ CAUTION: Explosive release of fluids from pressurized cooling system can cause serious burns.

Shut off engine. Only remove filler cap when cool enough to touch with bare hands. Slowly remove the pressure cap and allow pressure to relieve before completely removing cap.

NOTE: If COOL-GARD II is not used, the drain interval is reduced to 2000 hours or 24 months of operation.

1. Pressure test entire cooling system and pressure cap if not previously done. (See Pressure Testing Cooling System in the Lubrication & Maintenance — 500 Hours/12 Months Section.
2. Slowly open the engine cooling system filler cap or radiator cap to relieve pressure and allow coolant to drain faster.



High-Pressure Fluids

TS281 — JUN — 15APR13

Continued on next page

ZE59858,0000021 -19-12AUG14-1/2

NOTE: Drain coolant from the lowest point in the cooling system. This location will vary by application.

3. Drain all coolant from engine block.
4. Open radiator drain valve. Drain all coolant from radiator.
5. Remove thermostats at this time, if not previously done. Install cover (without thermostats and seals) and tighten socket head cap screws to specifications.

Specification

Thermostat Cover —
 Socket Head Cap
 Screws—Torque..... 73 N·m (54 lb.-ft.)

6. Close all drain valves after coolant has drained.

⚠ CAUTION: Do not run engine longer than 10 minutes. Doing so may cause engine to overheat which may cause burns when radiator water is draining.

7. Fill the cooling system with clean water. Run the engine about 7 minutes to stir up possible contaminants or foreign particles.
8. Stop engine, pull off lower radiator hose and remove radiator cap. Immediately drain the water from system before contaminants or foreign particles settle.
9. After draining water, close drain valves. Install radiator cap, radiator hose, and clamp. Fill the cooling system with clean water and a heavy duty cooling system cleaner such as Restore or Restore Plus. Follow manufacturer's directions on label.
10. After cleaning the cooling system, drain cleaner and fill with water to flush the system. Run the engine about 7 minutes. Stop engine, remove radiator cap and drain water.
11. Close all drain valves on engine and radiator.
12. Perform Testing Thermostat Opening Temperature in the Lubrication & Maintenance — 6000 Hours/72 Months Section.

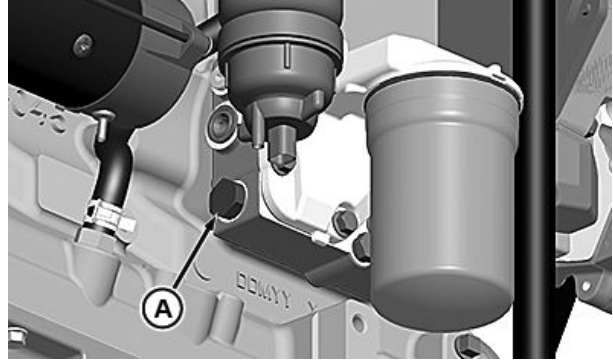

Engine Block Coolant Drain Plug—Right Side of Engine

A—Right Side of Engine Block Coolant Drain Plug

13. Install thermostats using a new gasket. Tighten thermostat cover socket head cap screws to specifications.

Specification

Thermostat Cover —
 Socket Head Cap
 Screws—Torque..... 73 N·m (54 lb.-ft.)

14. Add coolant to surge tank (See application manual for coolant volume).

Specification

4.5 L Engine—Coolant Capacity (Excluding Radiator)..... 8.5 L (9 qt.)

15. Run engine until it reaches operating temperature. This mixes the solution uniformly and circulates it through the entire system. The normal engine coolant temperature range is 85—103 °C (185—217 °F).
16. After running engine, check coolant level and entire cooling system for leaks.
17. Inspect the fan belt for wear and check belt tension. (See Checking Belt Wear in the Lubrication & Maintenance — 500 Hours/12 Months Section.

ZE59858,0000021 -19-12AUG14-2/2

RG26298 —UN—12AUG14

Testing Thermostat Opening Temperature

Removing Thermostats

⚠ CAUTION: Explosive release of fluids from pressurized cooling system can cause serious burns. **DO NOT** drain coolant until it has cooled below operating temperature. Always loosen radiator pressure cap or drain valve slowly to relieve pressure.



High Pressure Fluids

ZE59858,0000022 -19-18AUG14-1/4

TS281 —UN—15APR13

1. Visually inspect area around thermostat housing for leaks.
2. Remove radiator pressure cap and partially drain cooling system.
3. Remove three cap screws (C) and thermostat cover (B) clean and check cover for cracks or damage.
4. Remove both thermostats (A) from the housing.

A—Thermostats (2 Used)
B—Thermostat Cover

C—Cap Screws (3 Used)

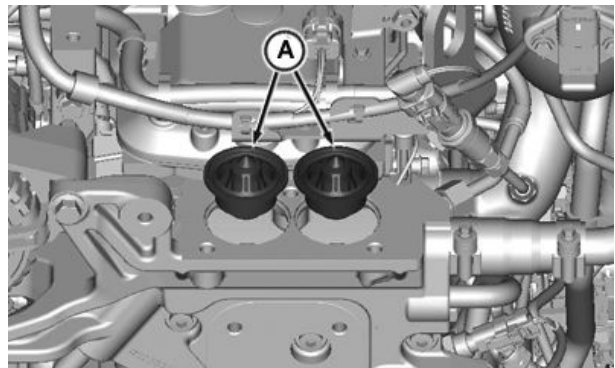
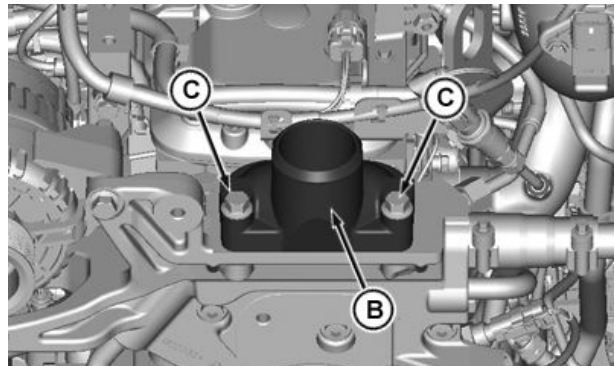

Removing Thermostats

Continued on next page

ZE59858,0000022 -19-18AUG14-2/4

RG20113 —UN—18MAR11

RG20112 —UN—18MAR11

Testing Thermostats Opening Temperature

NOTE: Perform the following test for both thermostats.

1. Visually inspect thermostats for corrosion or damage. Replace as a matched set, as necessary.

CAUTION: DO NOT allow thermostat or thermometer to rest against the side or bottom of container when heating water. Either may rupture if overheated.

2. Suspend thermostat and a thermometer in a container of water.
3. Stir the water as it heats. Observe opening action of thermostat and compare temperatures to specifications.

NOTE: Due to varying tolerances of different suppliers, initial opening and full open temperatures may vary slightly from specified temperatures.

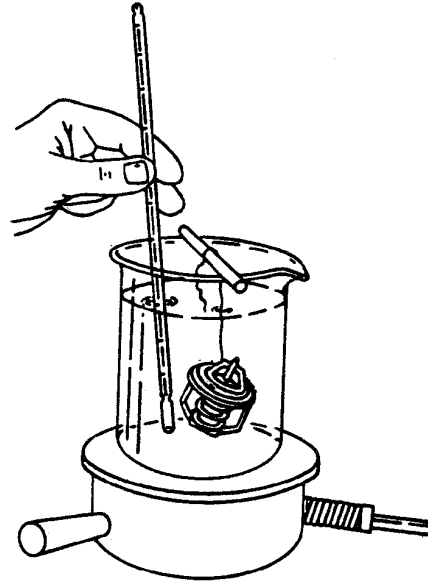

Testing Thermostat Opening Temperature

RG5971 —UN—23NOV97

Specification

Thermostat

Opening—Temperature..... 85 °C—97 °C (185 °F—207 °F)

4. Remove thermostat and observe its closing action as it cools. In ambient air the thermostat should close completely. Closing action should be smooth and slow.

5. If any thermostat is defective, replace both thermostats.

Continued on next page

ZE59858,0000022 -19-18AUG14-3/4

Installing Thermostats

1. Install new rubber seal for each thermostat (A).
2. Install thermostats into housing (D).
3. Install thermostat cover (B) and tighten thermostat cover cap screws (C) to specifications.

Specification

Thermostat Cover Cap
Screw—Torque..... 73 N·m (54 lb.-ft.)

4. Fill cooling system and check for leaks.

IMPORTANT: Air must be expelled from cooling system when refilled.

A—Thermostats
B—Thermostat Cover
C—Cap Screws (3 Used)
D—Thermostat Housing

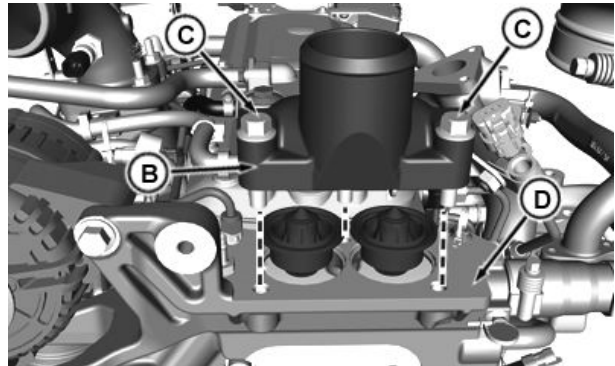
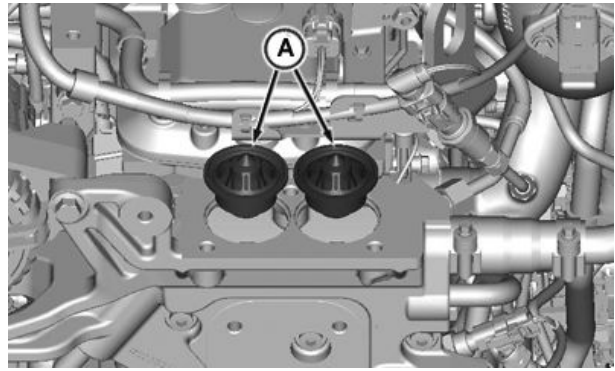

Installing Thermostats

ZE59858.0000022 -19-18AUG14-4/4

RG20112 —UN—18MAR11

RG25248 —UN—12MAR14

Change Diesel Exhaust Fluid (DEF) In-Line Filter

CAUTION: Avoid possible personal injury. In case of DEF contact, immediately flush eyes with large amounts of water for a minimum of 15 minutes. Reference the Materials Safety Data Sheet (MSDS) for additional information. Do not ingest DEF. In the event DEF is ingested, contact a physician immediately. Reference the Materials Safety Data Sheet (MSDS) for additional information.

IMPORTANT: Avoid corrosion of vehicle parts or surfaces. If DEF is spilled or contacts any surface other than the storage tank, immediately clean the surface with clear water. DEF is corrosive to painted and unpainted metallic surfaces and can distort some plastic and rubber components. Spilled DEF, if left to dry or if only wiped away with a cloth, will leave a white residue. Improperly cleaned DEF spill may interfere with diagnosis of Selective Catalytic Reduction (SCR) system leakage problems.

NOTE: See your John Deere equipment technical manual or OEM manufacturer's technical manual for in-line DEF filter location.

IMPORTANT: Avoid system and filter damage. Ensure that DEF system is not frozen before changing filter. If system is frozen, operate engine until system has thawed completely.

1. Remove drain plug with O-ring (A) and discard.

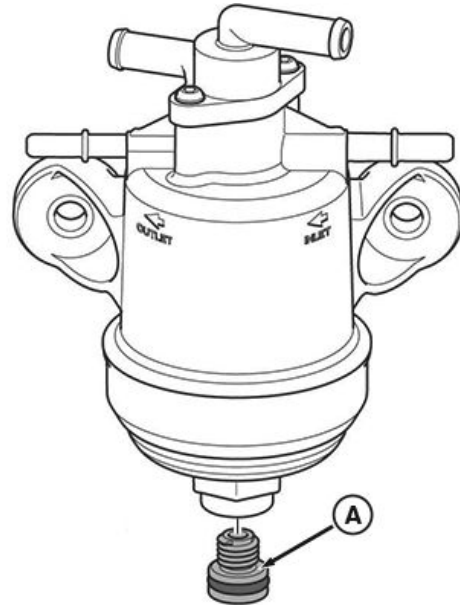

DEF Fluid Removal

A—Drain Plug with O-Ring

NOTE: Container must be DEF compatible and hold at least 300 mL (0.32 qt).

2. Drain DEF into a proper container.

DX,DEF,CHANGE,INLINE,FILT -19-15APR20-1/6

RG30728 —UN—08AUG18

3. Rotate filter housing (A) counterclockwise and pull down.
4. Remove and discard filter from housing (A).

NOTE: If necessary, tap filter to loosen from filter housing (A).

A—Filter Housing

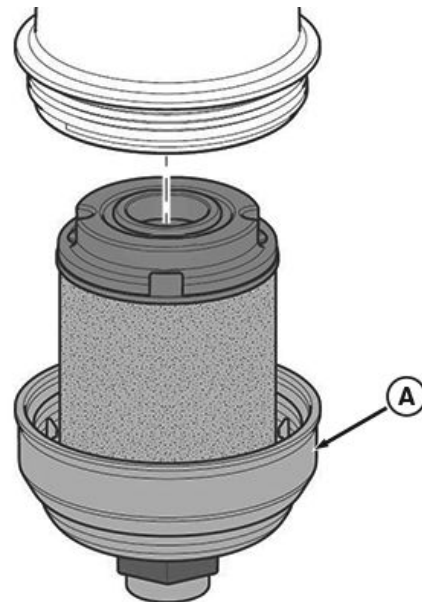

Filter Removal

Continued on next page

DX,DEF,CHANGE,INLINE,FILT -19-15APR20-2/6

RG30727 —UN—08AUG18

- Remove and discard O-ring (A) and foam compensation element (B).

NOTE: Filter housing should be cleaned with clean DEF before installing new components to remove any sediment debris or contamination.

- Install new O-ring (A) and foam compensation element (B) into filter housing (C).

A—O-Ring
B—Foam Compensation
Element

C—Filter Housing

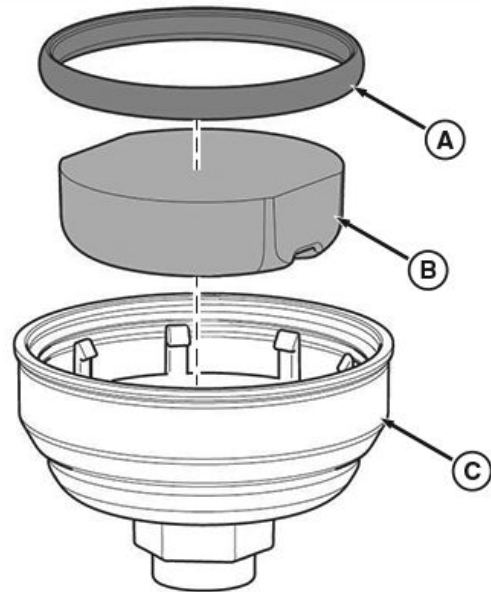

Filter Housing Components

DX,DEF,CHANGE,INLINE,FILT -19-15APR20-3/6

RG30726—UN—08AUG18

- Install new filter (A) into filter housing (B).

A—Filter

B—Filter Housing

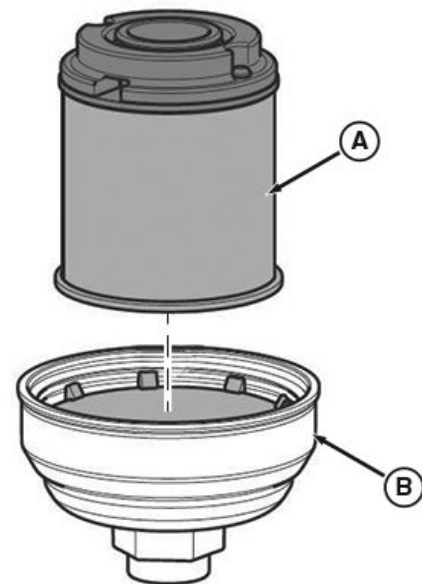

Filter Housing and Components Installation

Continued on next page

DX,DEF,CHANGE,INLINE,FILT -19-15APR20-4/6

RG30725—UN—08AUG18

8. Install filter housing (A) with O-ring, foam compensation element, and filter element.
9. Rotate filter housing (A) clockwise and tighten to specification.

Specification

In-Line DEF Filter	
Housing—Torque.....	25 N·m (221 lb·in)

A—Filter Housing

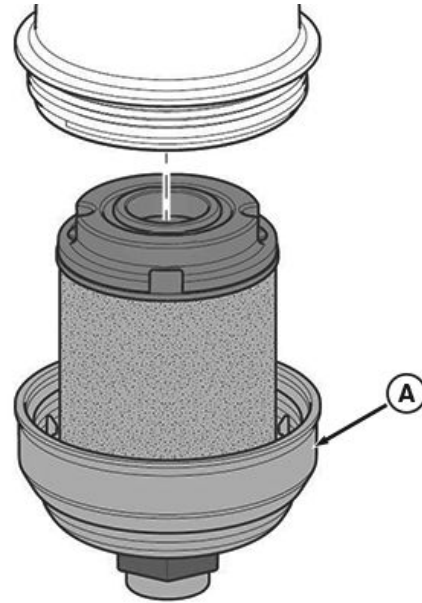

In-Line DEF Filter Housing Installation

DX,DEF,CHANGE,INLINE,FILT -19-15APR20-5/6

RG30727 —UN—08AUG18

10. Install new drain plug with O-ring (A). Tighten to specification.

Specification

In-Line DEF Filter Drain	
Plug—Torque.....	4 N·m (35 lb·in)

A—Drain Plug with O-Ring

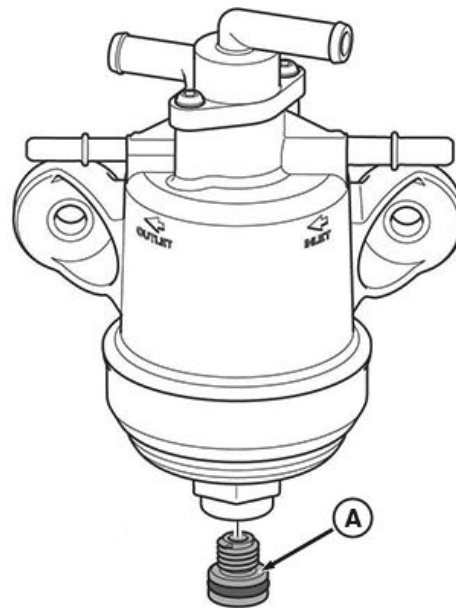

In-Line DEF Filter Drain Plug

DX,DEF,CHANGE,INLINE,FILT -19-15APR20-6/6

RG30728 —UN—08AUG18

Service As Required

Additional Service Information

This is not a detailed service manual. If you want more detailed service information, contact your John Deere dealer or engine distributor.

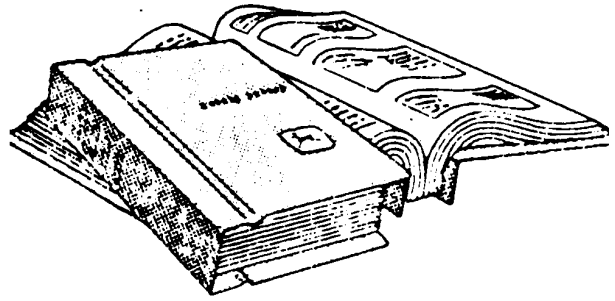

Component Technical Manuals

RK80614,0000038 -19-16OCT12-1/1

RG4624 —UN—15DEC88

Do Not Modify Fuel System

IMPORTANT: Modification or alteration of the high-pressure fuel pump, the injection timing, or the fuel injectors in ways not recommended by the manufacturer will terminate the warranty obligation to the purchaser.

In addition, tampering with fuel system which alters emission-related equipment on engines may result in fines or other penalties, per EPA regulations or other local emission laws.

Do not attempt to service fuel pump, fuel rail, or fuel injectors yourself. Special training and special tools are required. (See your authorized servicing dealer or engine distributor.)

Avoid seizure of internal precision parts in high-pressure fuel pump or fuel injection rail. Never steam clean or pour cold water on pump or rail while these components are warm from operation.

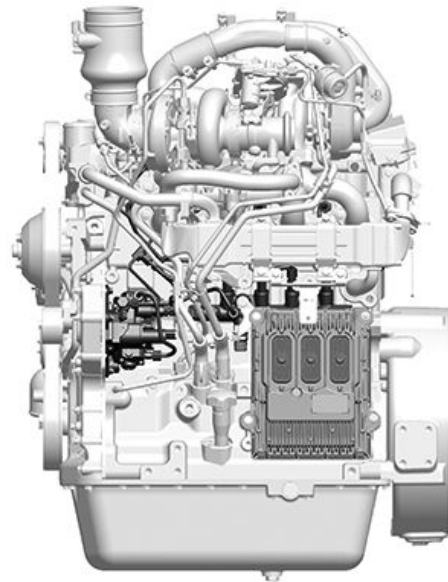

Fuel System

ZE59858,0000023 -19-30JUL14-1/1

RG26251 —UN—30JUL14

Drain Water From Fuel Filters

The primary fuel filter (A) is equipped with a sensor that detects the presence of water in the fuel filter element. This sensor will illuminate the "STOP ENGINE" warning light on the diagnostic gauge and also sound an audible alarm. A Diagnostic Trouble Code (DTC) will be displayed on the diagnostic gauge.

ALWAYS STOP ENGINE IMMEDIATELY and drain water from the primary fuel filter (A) when these warnings occur.

1. Loosen drain valve (B) to drain water and debris as needed.
2. Retighten valve securely.

NOTE: Replace fuel filter elements when amber indicator on instrument panel lights up AND Diagnostic Trouble Code (DTC) in diagnostic gauge window indicates plugged fuel filters ("low fuel pressure"). To replace fuel filter elements, see Removing and Installing Fuel Filters in the Lubrication & Maintenance — 500 Hours/12 Months Section.

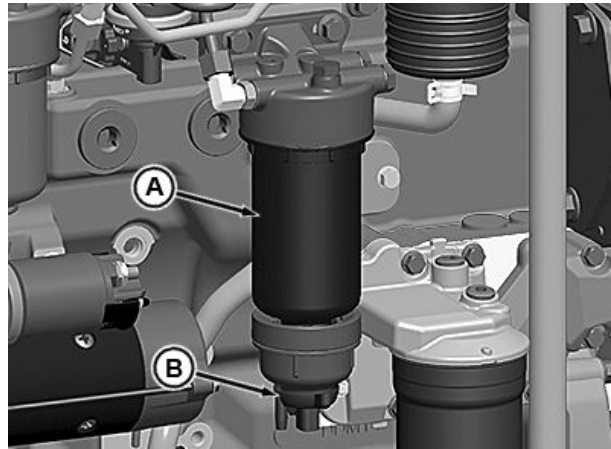

Drain Water From Fuel Filters

A—Primary Fuel Filter

B—Drain Valve

RG26256 —UN—30JUL14

ZE59858,0000024 -19-30JUL14-1/1

Adding Coolant

CAUTION: Explosive release of fluids from pressurized cooling system can cause serious burns.

Shut off engine. Only remove filler cap when cool enough to touch with bare hands. Slowly loosen cap to relieve pressure before removing completely.

IMPORTANT: Never pour cold liquid into a hot engine, as it may crack cylinder head or block. DO NOT operate engine without coolant for even a few minutes.

DO NOT use any other stop-leak additives in the cooling system. Leaks should be permanently repaired as quickly as possible.

Coolant level should be kept between the MIN COLD and MAX COLD marks on surge tank. Add coolant as follows:

1. Remove surge tank cap.

IMPORTANT: When adding coolant to the system, use the appropriate coolant solution. (See Diesel Engine Coolant (engine with wet sleeve



High Pressure Fluids

cylinder liners) in the Fuels, Lubricants, and Coolants Section for mixing of coolant ingredients before adding to system.)

Do not overfill cooling system. A pressurized system needs space for heat expansion without overflowing.

2. Fill surge tank until coolant level is at the MAX COLD mark on surge tank.
3. Reinstall surge tank cap.

TS281 —UN—15APR13

ZE59858,00000D6 -19-05FEB14-1/1

Cleaning Diesel Exhaust Fluid (DEF) Tank

⚠ CAUTION: Avoid contact with eyes. In case of contact, immediately flush eyes with large amounts of water for a minimum of 15 minutes. Reference the Materials Safety Data Sheet (MSDS) for additional information.

IMPORTANT: If DEF is spilled or contacts any surface other than the storage tank, immediately clean the surface with clear water. DEF is corrosive to painted and unpainted metallic surfaces and can distort some plastic and rubber components.

Spilled DEF, if left to dry or if only wiped away with a cloth, leaves a white residue. Improperly cleaned DEF spill can interfere with diagnosis of Selective Catalytic Reduction (SCR) system leakage problems.

If foreign material or fluid has been added to the DEF tank, drain the DEF tank, flush, and fill with new DEF.

If DEF quality is in question, pull a sample out of the DEF tank and place into a clear container. DEF should be crystal clear with a light ammonia smell. If DEF appears cloudy, has a colored tint, or has a profound ammonia smell, it is likely not within specification. DEF in this condition should not be used.

1. Remove drain plug (if equipped), and drain or siphon bad DEF from DEF tank.

NOTE: Cleaning can take place with DEF tank installed or removed.

2. Clean DEF tank with new DEF.

DEF must pass visual, smell, and concentration checks before running the engine. See Diesel Exhaust Fluid (DEF) – For Use In Selective Catalytic Reduction (SCR) Equipped Engines in the Fuels, Lubricants, and Coolants Section for more information.

3. Drain or siphon DEF tank.

NOTE: Repeat steps 2—3 until DEF tank has been cleaned.

4. **Early version:** Change DEF dosing unit filter and DEF tank header suction screen.

Later version: Change DEF dosing unit filter and DEF inline filter.

5. If removed, install DEF tank drain plug.

6. If removed, install DEF tank.

7. Fill DEF tank with new DEF.

8. Check DEF concentration with DEF refractometer, such as JDG11594 or JDG11684. The correct DEF concentration is 31.8% — 33.2%. See your authorized dealer for more information.

9. If DEF is not within specification, does not appear clear, or does not have a slight ammonia smell, contact your authorized dealer.

DX,DEF,CLEANTANK -19-18SEP19-1/1

Pre-Start Cleaning Guide

⚠ CAUTION: Avoid injury. Before cleaning machine, allow ample time for hot surfaces to cool.

IMPORTANT: Avoid machine damage. Do not direct high-pressure spray from hose output directly at or close to electrical connections and sensors.

Cleaning as needed is recommended. Clean more frequently during heavy machine use, and when weather conditions are dry.

- Check enclosed areas daily. Clean the engine and other enclosed areas of equipment to remove debris and any buildup of oil and grease. Keep the engine and engine compartment free of combustible material.
- Check for debris buildup daily on and around intake systems, exhaust systems, and intercooler piping systems. Verify that there are no holes or leaks in intake or exhaust systems. Do not allow debris to build up near hot exhaust components. Verify that hot exhaust components are cleaned as often as environmental conditions require.
- Inspect cooling system daily to determine whether cooling system needs cleaning. Visible buildup of

residue that blocks airflow may degrade machine performance and requires more frequent cleaning depending on environmental conditions.

- Inspect difficult to observe areas daily as conditions may require additional cleaning care to remove debris.
- Check for oil and fuel leaks daily. Replace or repair sources of leaks, including gaskets, seals, breather tubes, fittings, and fluid lines.

Maintenance and Service Reminders

- Keep surfaces free of grease and oil.
- Clean up hydraulic and other fluid leaks.
- Fuel Lines — Check for leaks, cracks, and kinks.
- Fuel Pumps — Check fittings, especially compression ring couplings, for cracks and leaks.
- Fuel Injectors — Check pressure and return lines for signs of leaks.
- When servicing fuel filter or draining water separator, avoid fuel spills. Immediately clean up any fuel spill.
- Check for transmission case venting system seepage, transmission case leakage, power steering cylinder leakage, or power steering line leakage.
- Check for loose electrical connectors, damaged wiring, corrosion, or poor connections.

ZE59858,0000009 -19-07JUL20-1/1

Replacing Air Filter Element

IMPORTANT: ALWAYS REPLACE primary air cleaner element when air filter restriction indicator shows a vacuum of 625 mm (25 in.) H₂O, is torn, or visibly dirty.

NOTE: This procedure applies to John Deere 2-stage radial seal air cleaner kits. Refer to manufacturers' instructions for servicing air cleaners not supplied by John Deere.

1. Unlatch and remove dust cap/cover (A) of air cleaner.
2. Move end of filter (B) back and forth gently to break seal.
3. Pull filter (B) off outlet tube and out of housing.
4. Thoroughly clean all dirt from inside housing and from outlet bore.

IMPORTANT: Remove secondary (safety) element (C) ONLY for replacement. DO NOT attempt to clean, wash, or reuse secondary element. Replacement of secondary element is usually necessary ONLY when primary element has a hole in it.

5. To replace secondary element (C), pull filter element out gently. Immediately replace secondary element with new element to prevent dust from entering air intake system.
6. Install new primary filter element. Apply pressure by hand at outer rim of filter.

IMPORTANT: Do NOT use latches on cover to force filter into air cleaner. Using cover to force filter will damage cleaner housing.

7. Close housing with dust unloader valve aimed down and latch latches.

IMPORTANT: Whenever the air cleaner has been serviced or cover has been removed, ALWAYS fully depress the air filter restriction indicator reset button (if equipped) to assure accurate readings.

8. If equipped, fully depress air filter restriction indicator reset button and release to reset indicator.



Dust Cap/Cover



Primary Filter Element

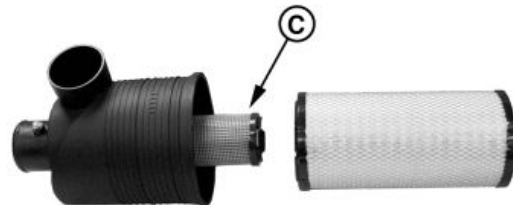

Secondary Filter Element

A—Dust Cap/Cover
B—Primary Filter Element

C—Secondary Filter Element

RG11321A—UN—08SEP00

RG11322A—UN—08SEP00

RG11327A—UN—08SEP00

ZE59858,0000113 -19-26AUG13-1/1

Inspecting Primary Air Filter Element

1. Hold a bright light (A) inside element and check carefully for holes. Discard any element which shows the smallest hole or rupture.
2. Be sure outer screen (B) is not dented. Vibration would quickly wear a hole in filter.
3. Be sure filter gasket (C) is in good condition. If gasket is damaged or missing, replace element.

IMPORTANT: Air cleaner MUST BE DRY before storing in plastic bag.

If the filter is to be stored for later use, place it in a plastic bag to protect it from dust and damage.

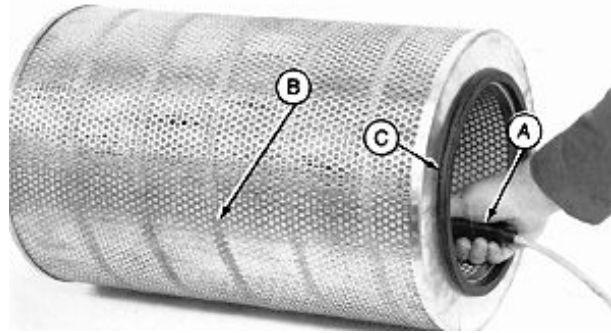

Inspecting Primary Air Filter Element

A—Light
B—Outer Screen

C—Gasket

RW4768 —UN—15DEC88

RK80614,000003D -19-16OCT12-1/1

Air Filter Element Storage

IMPORTANT: Air cleaner element MUST BE DRY before storing in plastic bag.

Seal element in a plastic bag and store in shipping container to protect against dust and damage.

RK80614,000003F -19-26AUG13-1/1

Cleaning the Exhaust Filter

The exhaust filter requires periodic maintenance. Some of the maintenance is transparent to the operator. During continuous heavy loads and other conditions, the engine creates enough heat to clean a small amount of soot build-up in the exhaust filter. When the exhaust filter has accumulated higher levels of soot, the ECU requests (depending on predefined user settings) an exhaust filter cleaning. During this request, move the equipment to a suitable location with adequate ventilation.

The following symbols may be displayed on the operator interface.

IMPORTANT: During an exhaust filter cleaning verify the area surrounding the engine is free of any flammable objects as temperatures can reach as high as 550°C (1022°F).

NOTE: For more information on the operator interface icons or exhaust filter cleaning procedures, see the **Aftertreatment System** section.

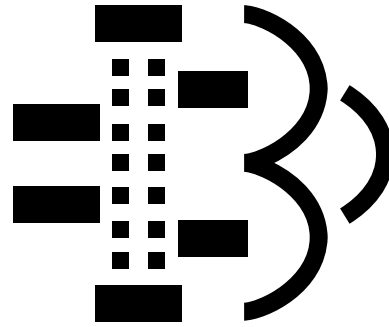

Exhaust Filter Cleaning is Needed

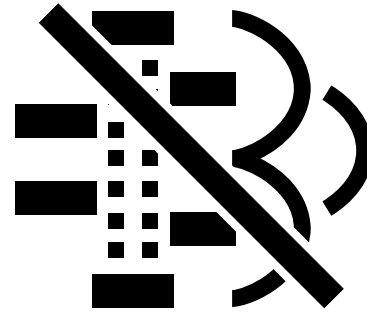

Exhaust Filter Cleaning is Disabled

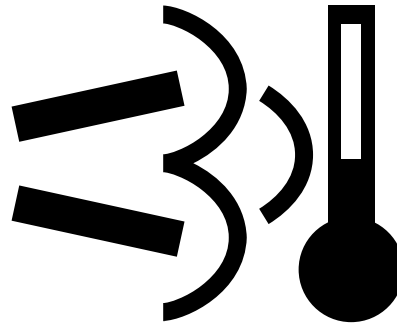

Emission System Temperature is High or Exhaust Filter Cleaning is Underway

KW40574,000000B -19-09MAY16-1/1

RG16860—UN—01APR10

RG16861—UN—01APR10

RG16862—UN—01APR10

Replacing Fan Belt

See [Checking Tensioner Spring Tension](#) in the Lubrication & Maintenance — 500 Hours/12 Months Section for additional information on the belt tensioner.

1. Inspect belt for cracks, fraying, or stretched out areas. Replace if necessary.
2. To replace belt with automatic tensioner, release tension on belt using a long handled 1/2 inch drive tool in square hole in end of tensioner arm.
3. Remove poly-vee belt from pulleys and discard belt.

NOTE: While belt is removed, inspect pulleys and bearings. Rotate and feel for hard turning or any unusual sounds. If pulleys or bearings need replacement, see your John Deere dealer.

4. Install new belt, making sure that belt is correctly seated in all pulley grooves. Text on belt (such as John Deere or part number) should be readable when standing at the front of the engine looking back toward the rear. Refer to belt routing at right for your application.
5. Apply tension to belt with tensioner. Remove drive tool.
6. Install fan guard if removed.
7. Start engine and check belt alignment.

A—Alternator	I— Idler Pulley
A/C— Refrigerant Compressor	T— Tensioner
CSP—Crankshaft Pulley	CP—Coolant Pump
FD—Fan Drive	

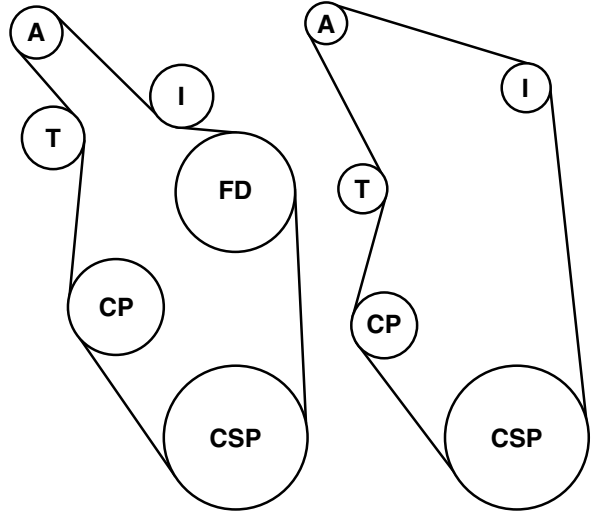

RG26257 —UN—30JUL14

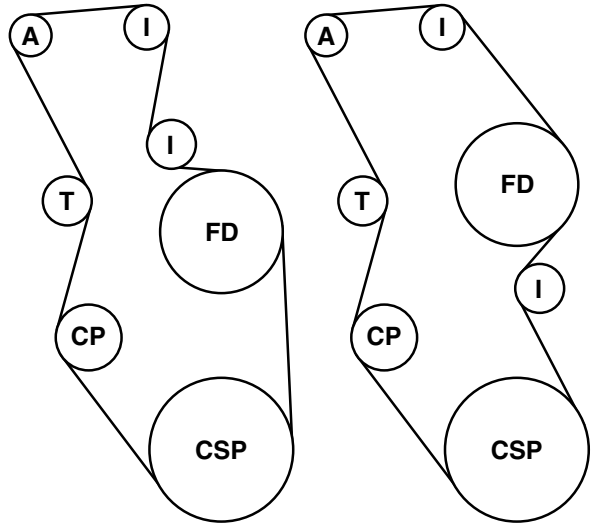

RG26258 —UN—30JUL14

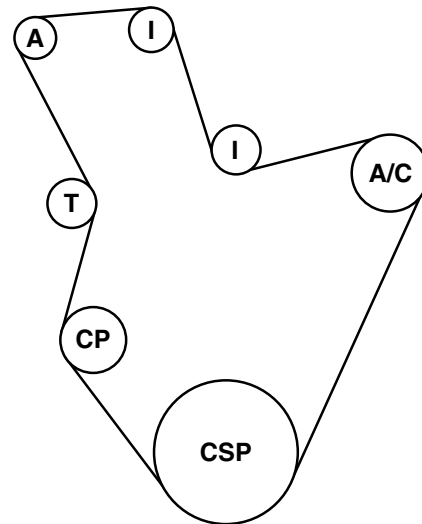

RG26259 —UN—30JUL14

AT89373,0000003 -19-30JUL14-1/1

Checking Fuses

Check the following fuses located in the control panel wiring harness. Replace defective fuses.

- Control Panel fuse — 30 Amp

- JD Link fuse — 10 Amp
- ECU fuse — 25 Amp (3 used)
- TVP fuse — 30 Amp

See [4.5 L Wiring Diagram 10](#) in the Troubleshooting Section.

ZE59858.0000025 -19-18AUG14-1/1

Checking Electrical Wiring And Connections

Check for loose or corroded wiring and connectors. Tighten connections or replace wiring as needed. See your authorized servicing dealer for repairs.

RK80614.0000043 -19-16OCT12-1/1

Bleeding Fuel System

NOTE: Normally the fuel system on these engines is self-priming and self-bleeding, and does not require a bleeding procedure by the operator.

If engine will not start after filter changes, turn ignition key ON for 60 seconds to prime the fuel system. It may be necessary to turn the key off and on again to reprime the system before starting.

RK80614.0000044 -19-19MAY20-1/1

Checking Air Compressors (If Equipped)

Air compressors are offered as an option with John Deere OEM engines to provide compressed air to operate air-powered devices.

Air compressors are engine-driven, piston type devices. They are either air cooled or cooled with engine coolant. The compressors are lubricated with engine oil. The compressor runs continuously by gear or spline drive by the auxiliary drive of the engine, but has “loaded” and “unloaded” operating modes. This is controlled by the vehicle's air system (refer to vehicle technical manual for complete air system checks and services).

See the John Deere engine distributor or servicing dealer for diagnostic and troubleshooting information. If diagnosis leads to an internal fault in the compressor, replace the complete compressor with a new or remanufactured unit.

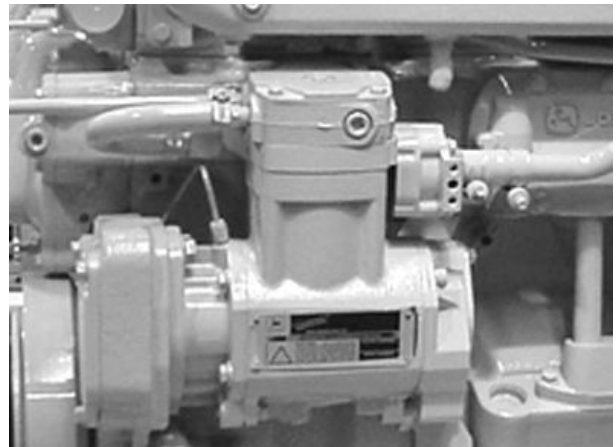

Air Conditioner Compressor (Option A)

RG12738 — JUN — 07NOV02

RK80614.0000045 -19-25JUN21-1/1

Checking Refrigerant (A/C) Compressor (If Equipped)

Contact your authorized servicing dealer for any service or repairs to the air conditioning system.

RK80614.0000046 -19-16OCT12-1/1

Replace Aftertreatment DEF Dosing System Coolant Filter

NOTE: Aftertreatment DEF dosing system coolant filter location varies by application.

On some applications, a replaceable filter is in-line with the coolant supply hose to the aftertreatment DEF tank header. This filters coolant as it flows to the aftertreatment DEF tank header. See your qualified engine service provider for diagnostic and troubleshooting information.

- | | |
|-----------------------|---|
| A—Coolant Supply Hose | C—Aftertreatment DEF Dosing System Coolant Filter |
| B—Hose Clamp | D—P-Clamp |

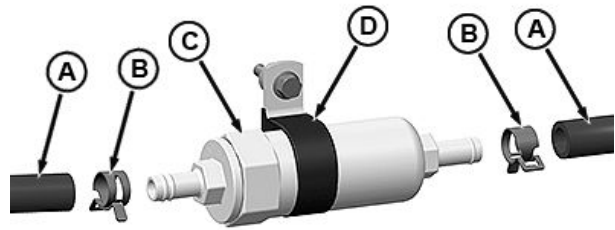

Aftertreatment DEF Dosing System Coolant Filter Assembly

AT89373,0000B5A -19-20MAY15-1/1

RG26975—UN—31MAR15

DEF Tank Inlet Screen — Installation

CAUTION: Avoid possible personal injury. In case of DEF contact, immediately flush eyes with large amounts of water for a minimum of 15 minutes. Reference the Materials Safety Data Sheet (MSDS) for additional information.

Do not ingest DEF. In the event DEF is ingested, contact a physician immediately. Reference the Materials Safety Data Sheet (MSDS) for additional information.

IMPORTANT: Avoid corrosion of vehicle parts or surfaces. If DEF is spilled or contacts any surface other than the storage tank, immediately clean the surface with clear water. DEF is corrosive to painted and unpainted metallic surfaces and can distort some plastic and rubber components.

Spilled DEF, if left to dry or if only wiped away with a cloth, will leave a white residue. Improperly cleaned DEF spill may interfere with diagnosis of Selective Catalytic Reduction (SCR) system leakage problems.



A—DEF Tank Inlet Screen

1. Thoroughly clean the area around the DEF tank inlet for any debris.
2. If there is any evidence that debris has entered the DEF tank, the tank must be drained and thoroughly cleaned.
3. Carefully insert DEF tank inlet screen (A) into DEF tank.
4. Ensure DEF tank inlet screen clicks and locks into place.
5. Install DEF tank cap.

RE42287,0001327 -19-23OCT20-1/1

RG31991—UN—10DEC19

DEF Tank Inlet Screen — Removal

CAUTION: Avoid possible personal injury. In case of DEF contact, immediately flush eyes with large amounts of water for a minimum of 15 minutes. Reference the Materials Safety Data Sheet (MSDS) for additional information.

Do not ingest DEF. In the event DEF is ingested, contact a physician immediately. Reference the Materials Safety Data Sheet (MSDS) for additional information.

IMPORTANT: Avoid corrosion of vehicle parts or surfaces. If DEF is spilled or contacts any surface other than the storage tank, immediately clean the surface with clear water. DEF is corrosive to painted and unpainted metallic surfaces and can distort some plastic and rubber components.

Spilled DEF, if left to dry or if only wiped away with a cloth, will leave a white residue. Improperly cleaned DEF spill may interfere with diagnosis of Selective Catalytic Reduction (SCR) system leakage problems.

1. Thoroughly clean the area around the DEF tank inlet of any debris or contaminants.
2. Remove DEF tank cap.
3. Insert screwdrivers (A) at each tab location (B).

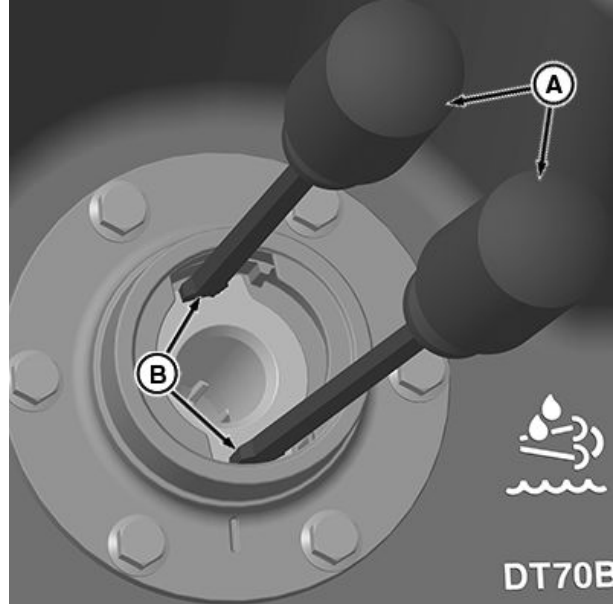

DEF Tank Inlet Screen Removal

A—Screwdriver (2 used)

B—Locking Tab (2 used)

4. Gently push screwdrivers (A) towards DEF tank fill hole.

RE42287.0001328 -19-23OCT20-1/2

5. While pushing locking tabs (B) towards DEF tank fill hole, pull screwdrivers upward to remove DEF tank inlet screen (C).
6. Inspect the DEF tank inlet screen (C) for damage or missing pieces.
7. If any damage or missing pieces are identified then the DEF tank must be drained and thoroughly clean of debris.
8. Clean or replace DEF tank inlet screen as required.

A—Screwdriver (2 used)
B—Locking Tab (2 used)

C—DEF Tank Inlet Screen

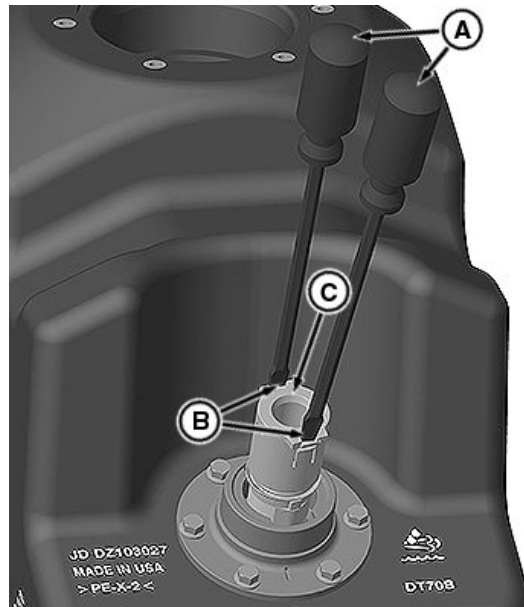

DEF Tank Inlet Screen Removal

RE42287.0001328 -19-23OCT20-2/2

Troubleshooting

General Troubleshooting Information

In this section, there is a list of possible engine problems that may be encountered, accompanied by possible causes and corrections. The illustrated diagrams and troubleshooting information are of a general nature. Final design of the overall system for your engine application may be different. See the engine distributor or servicing dealer for questions.

A reliable program for troubleshooting engine problems should include the following basic diagnostic process:

- Know the engine and all related systems.
- Study the problem thoroughly.
- Relate the symptoms to your knowledge of engines.
- Diagnose the problem starting with the easiest things first.
- Double-check before beginning the disassembly.

- Determine cause and make a thorough repair.
- After making repairs, operate the engine under normal conditions to verify that the problem and cause was corrected.

NOTE: All engines have electronic control systems which may send diagnostic trouble codes to signal problems, see Diagnostic Trouble Codes (DTCs) — Operation in the troubleshooting section.

1. *If fault codes are present, follow the appropriate DTC procedure.*
2. *If the problem is not corrected, contact the servicing dealer.*
3. *If engine has problems, but no fault codes are displayed, see Engine Troubleshooting in the troubleshooting section.*

EP89502,0000001 -19-07JUL20-1/1

Diagnostic Trouble Codes (DTCs) — Listing

NOTE: Not all of these codes are used in all engine applications.

NOTE: Not all DTCs are listed below. See your application technical manual for more information.

There are several possible combinations of SPN and FMI codes. To use the table below, first write down the SPN and FMI codes you received from the engine diagnostic gauge. Locate each SPN and its associated definition. In the same way, locate the FMI and its associated definition.

FMI Code	FMI Name
0	Extremely High
1	Extremely Low
2	Invalid
3	Out of Range High
4	Out of Range Low
5	High Resistance
6	Low Resistance
7	Mismatch
8	Signal Missing
9	Loss of Communication
10	Change Abnormal
11	Activated
12	Error
13	Fault
14	Incorrect Message
15	Slightly High
16	Moderately High
17	Slightly Low
18	Moderately Low
19	Communication Error
31	Condition Exists

SPN Code	SPN Name
27	EGR Valve Position Signal
51	Air Throttle Actuator Position Signal
94	Low Pressure Fuel Pressure Signal
97	Water-in-fuel Signal
100	Engine Oil Pressure Signal
101	Crankcase Pressure
102	Manifold Air Pressure Signal
103	VGT Speed Signal
105	Manifold Air Temperature Signal
107	Air Filter Pressure Differential
108	Barometric Pressure Signal
109	Engine Coolant Pressure Signal
110	Engine Coolant Temperature Signal
111	Engine Coolant Level Alarm Switch
157	Fuel Rail Pressure Signal
158	ECU Power Down
168	Unswitched Battery Voltage
174	Fuel Temperature Signal
189	Engine Speed Derate

Continued on next page

ZE59858,0000026 -19-01AUG16-1/3

Troubleshooting

SPN Code	SPN Name
190	Engine Speed
412	EGR Temperature Signal
611	Injector Drive #1
612	Injector Drive #2
613	Fuel Pressure Control Valve Drive
629	ECU EEPROM
636	Camshaft Position Signal
637	Crankshaft Position Signal
651	Injector #1
652	Injector #2
653	Injector #3
654	Injector #4
655	Injector #5
656	Injector #6
695	Unapproved Engine Speed Request
970	External Shutdown Switch
1075	Low Pressure Fuel Pump Data
1136	ECU Temperature Signal
1172	Intake Air Temperature
1176	Intake Air Pressure
1180	Calculated VGT Turbine Inlet Temp
1209	Exhaust Manifold Pressure Signal
1347	Fuel Pump Pressure Control Valve 1
1348	Fuel Pump Pressure Control Valve 2
1321	Engine Starter Control Circuit
1569	Engine Power Derate
1761	DEF Tank Fuel Level Signal
2002-2253	Source Address 2-253
2629	Fixed Turbo Comp Outlet Temp Signal
2630	Charge Air Cooler Outlet Temp Signal
2659	EGR Flow Signal
2790	Fixed Turbocharger Comp Outlet Temp
2791	EGR Valve Drive Circuit
2795	VGT Calibration Version
2797	Injector High Voltage Supply #1
2798	Injector High Voltage Supply #2
3031	DEF Tank Fluid Temp Signal
3216	DPF Outlet NOx
3226	SCR Outlet NOx
3246	DPF Outlet Temperature
3251	DPF Differential Pressure Signal
3361	DEF Dosing Injector Signal

Continued on next page

ZE59858,0000026 -19-01AUG16-2/3

Troubleshooting

SPN Code	SPN Name
3464	Air Throttle Actuator Drive Circuit
3509	Sensor Supply #1 Voltage
3510	Sensor Supply #2 Voltage
3511	Sensor Supply #3 Voltage
3512	Sensor Supply #4 Voltage
3513	Sensor Supply #5 Voltage
3514	Sensor Supply #6 Voltage
3516	Aftertreatment DEF Concentration
3517	DEF Tank Fluid Level
3597	Injector Power Supply Voltage
3719	Calculated Soot Level
3720	Calculated Ash Level
3936	DPF Fault Occurrences
4334	DEF Dosing Unit Outlet Pressure
4341	DEF Dosing Unit Pressure line Heater
4343	DEF Dosing Unit Supply Line Heater
4345	DEF Dosing Unit Return Line Heater
4360	SCR Inlet Temperature
4363	SCR Outlet Temperature
4364	SCR Catalyst Conversion Efficiency
4366	DEF Tank Heater Coolant Valve
4376	Reversing Valve
4490	Intake Air Humidity
4765	DOC Inlet Temp
4766	DOC Outlet Temp
4795	DPF Missing
5018	DOC Fault Occurrences
5125	Sensor Supply #7 Voltage
5126	Sensor Supply #8 Voltage
5127	Sensor Supply #9 Voltage
5298	DOC Efficiency
5435	DEF Dosing Unit Pump
5571	HPCR Pressure Relief Valve
5743	SCR Temperature Module
5745	DEF Dosing Unit Heater
522494	Intake Air Sensor Communication
522495	Exhaust Filter Temp Module

NOTE: Diagnostic gauge on instrument panel may also display text for communication faults, such as "CAN Bus FAILURE". Contact your servicing dealer.

ZE59858,0000026 -19-01AUG16-3/3

Diagnostic Trouble Codes (DTCs) — Operation

SPN/FMI CODES

Stored and active diagnostic trouble codes are output on the diagnostic gauge on the Deere electronic instrument panel according to the J1939 standard as a two-part code as shown on the tables on the following pages.

The first part is a Suspect Parameter Number (SPN) followed by a Failure Mode Identifier (FMI) code. In order to determine the exact failure, both parts (SPN and FMI) of the code are needed.

The SPN identifies the system or the component that has the failure; for example SPN 000110 indicates a failure in the engine coolant temperature circuit.

The FMI identifies the type of failure that has occurred; for example FMI 03 indicates value above normal. Combining SPN 000110 with FMI 03 yields a fault code “engine coolant temperature input voltage too high”. A corrective action will also be displayed, “check sensor and wiring”. If this check does not solve the engine fault, contact your servicing dealer.

Always contact your servicing dealer for help in correcting unsolved diagnostic trouble codes which are displayed for your engine.

RK80614,000004A -19-26AUG13-1/1

Intermittent DTC Diagnostics

Intermittent DTCs are problems that periodically “go away”. A problem such as a terminal that intermittently does not make contact can cause an intermittent DTC. Other intermittent DTCs may be set only under certain operating conditions such as heavy load, extended idle, etc. When diagnosing intermittent DTCs, take special note of the condition of wiring and connectors since a high percentage of intermittent problems originates here. Check for loose, dirty, or disconnected connectors. Inspect the wiring routing, looking for possible shorts caused by contact with external parts (for example, rubbing against sharp sheet metal edges). Inspect the connector vicinity, looking for wires that have pulled out of connector terminals, damaged connectors, poorly positioned terminals, and corroded or damaged splices and terminals. Look for broken wires, damaged splices, and wire-to-wire shorts. Use good judgment if component replacement is thought to be required.

NOTE: The engine control unit (ECU) is the component LEAST likely to fail.

Suggestions for diagnosing intermittent DTCs:

- If diagnostic charts on preceding pages indicate that the problem is intermittent, try to reproduce the operating conditions that were present when the DTC set.
- If a faulty connection or wire is suspected to be the cause of the intermittent problem: clear DTCs, then check the connection or wire by wiggling it while watching the diagnostic gauge to see if the fault resets.

Possible causes of intermittent DTCs:

- Poor connection between sensor or actuator harness.
- Poor contact between terminals in connector.
- Poor terminal/wire connection.
- Electromagnetic interference (EMI) from an improperly installed 2-way radio, etc., can cause faulty DTCs to appear.

RK80614,000004C -19-23AUG21-1/1

Engine Troubleshooting

NOTE: Before troubleshooting the engine, first retrieve any fault codes on the diagnostic gauge

display and perform the corrective actions. If any problems remain, use the following charts to solve engine problems.

Symptom	Problem	Solution
Engine Will Not Crank	Low battery output voltage or discharged battery	Charge or replace batteries.
	Loose or corroded connections	Clean and tighten connections.
	Faulty start circuit relay	See your authorized John Deere engine distributor or servicing dealer.
	Blown fuse	Replace fuse.
	Defective main switch or start safety switch	Repair switch as required.
	Starter solenoid defective	Replace solenoid.
	Starter defective	Replace starter.
Starter Cranks Slowly	Low battery output voltage or discharged battery	Charge or replace batteries.
	Too high viscosity crankcase oil	Drain crankcase oil and replace with correct viscosity oil.
	Loose or corroded connections	Clean and tighten connections.
Hard to Start or Will Not Start	Engine starting under load	Disengage PTO.
	Improper starting procedure	Review starting procedure.
	Exhaust restricted	Check and correct exhaust restriction.
	No fuel	Check fuel tank.
	Air in fuel line	Bleed fuel lines.
	Poor fuel quality	Drain fuel and replace with proper grade and quality of fuel for operating condition.
	Water, dirt, or air in fuel system	Drain, flush, fill, and bleed fuel system.
	Fuel filter restricted or full of water	Replace fuel filter or drain water from fuel filter.

Continued on next page

ZE59858,00000CB -19-30JUL13-1/12

Troubleshooting

Symptom	Problem	Solution
	Dirty or faulty fuel injectors	See your authorized John Deere engine distributor or servicing dealer.
	Electronic fuel system problem	See your authorized John Deere engine distributor or servicing dealer.
	Cold weather	Use cold weather starting aids. See <u>Cold Weather Operation</u> in the Engine Operation Section.
	Too high viscosity crankcase oil	Drain crankcase oil and replace with correct viscosity oil.
	Electronic Control System Problem or Basic Engine Problem	See your authorized John Deere engine distributor or servicing dealer.
Engine Misfiring or Runs Irregularly	Poor fuel quality	Incorrect fuel/dirty fuel Test fuel, drain water from fuel bowl.
	Restricted fuel filter	Replace fuel filter element.
	Water, dirt, or air in fuel system	Drain, flush, fill, and bleed fuel system.
	Low coolant temperature	Remove and check thermostat.
	Dirty or faulty fuel injectors	See your authorized John Deere engine distributor or servicing dealer.
	Electronic fuel system problem	See your authorized John Deere engine distributor or servicing dealer.
	Electronic Control System problem or basic engine problem	See your authorized John Deere engine distributor or servicing dealer.
	Lack of Engine Power	Intake air restriction
Exhaust restricted		Check and correct exhaust restriction.
Poor fuel quality		Drain fuel and replace with proper grade and quality of fuel for operating condition.
Restricted fuel filter		Replace fuel filter elements.
Engine overloaded		Reduce engine load.

Continued on next page

ZE59858,00000CB -19-30JUL13-2/12

Troubleshooting

Symptom	Problem	Solution
	Improper crankcase oil	Drain crankcase oil and replace with correct viscosity oil.
	Low coolant temperature	Remove and check thermostat.
	Improper valve clearance	Adjust valve clearance. See Adjusting Valve Clearance in the <i>Lubrication & Maintenance — 3000 Hours/36 Months</i> .
	Dirty or faulty fuel injectors	See your authorized John Deere engine distributor or servicing dealer.
	Turbocharger not functioning properly	See your authorized John Deere engine distributor or servicing dealer.
	Air leak in engine intake or exhaust manifold	Check intake and exhaust manifold gaskets and manifolds; repair as required. See your authorized John Deere engine distributor or servicing dealer.
	Engine is in derate due to DTC	See your authorized John Deere engine distributor or servicing dealer.
	Electronic Control System problem or basic engine problem	See your authorized John Deere engine distributor or servicing dealer.
Engine Idles Poorly	Poor fuel quality	Drain fuel and replace with proper grade and quality of fuel for operating condition.
	Electronic control system problem or basic engine problem	See your authorized John Deere engine distributor or servicing dealer.
Excessive Fuel Consumption	Engine overloaded	Reduce engine load.
	Air cleaner restricted or dirty	Replace air cleaner element as required.
	Compression too low	Determine cause of low compression and repair as required.
	Leaks in fuel supply system	Locate source of leak and repair as required.
	Improper type of fuel	Drain fuel and replace with proper grade and quality of fuel for operating condition.

Continued on next page

ZE59858,00000CB -19-30JUL13-3/12

Troubleshooting

Symptom	Problem	Solution
	Poor fuel quality	Drain fuel and replace with proper grade and quality of fuel for operating condition.
	Improper valve clearance	Adjust valve clearance. See <u>Adjusting Valve Clearance</u> in the <u>Lubrication & Maintenance — 3000 Hours/36 Months</u> .
	Dirty or faulty fuel injectors	See your authorized John Deere engine distributor or servicing dealer.
	Electronic fuel system problem	See your authorized John Deere engine distributor or servicing dealer.
	Electronic Control System problem or basic engine problem	See your authorized John Deere engine distributor or servicing dealer.
	Turbocharger not functioning properly	Inspect turbocharger. See your authorized John Deere engine distributor or servicing dealer.
	Low engine temperature	Remove and check thermostat.
Fuel in Oil	Restricted fuel return line	Check and fix fuel return lines.
	Engine load too light	Increase engine load
	Leaking fuel injectors	See your authorized John Deere engine distributor or servicing dealer.
Low-Pressure Fuel System — Fuel Pressure Low	Restricted fuel filter	Replace fuel filter.
	Restricted fuel line	Locate restriction, repair as required.
	Faulty transfer pump	See your authorized John Deere engine distributor or servicing dealer.
	Faulty high-pressure fuel pump	Remove fuel pump, repair/replace pump as required. See your authorized John Deere engine distributor or servicing dealer.
Abnormal Engine Noise	Worn main or connecting rod bearings	Determine bearing clearance. See your authorized John Deere engine distributor or servicing dealer.

Continued on next page

ZE59858,00000CB -19-30JUL13-4/12

Troubleshooting

Symptom	Problem	Solution
	Excessive crankshaft end play	Check crankshaft end play. See your authorized John Deere engine distributor or servicing dealer.
	Loose main bearing caps	Check bearing clearance; replace bearings and bearing cap screws as required. See your authorized John Deere engine distributor or servicing dealer.
	Worn connecting rod bushings and piston pins	Inspect piston pins and bushings. See your authorized John Deere engine distributor or servicing dealer.
	Scored pistons	Inspect pistons. See your authorized John Deere engine distributor or servicing dealer.
	Worn timing gears or excess backlash	Check timing gear back lash. See your authorized John Deere engine distributor or servicing dealer.
	Excessive valve clearance	Check and adjust valve clearance. See Adjusting Valve Clearance in the Lubrication & Maintenance 3000 Hours/36 Months Section.
	Worn camshaft lobes	Inspect camshaft. See your authorized John Deere engine distributor or servicing dealer.
	Worn rocker arm shaft(s)	Inspect rocker arm shafts. See your authorized John Deere engine distributor or servicing dealer.
	Worn valve guides	Check valve guides for wear. See your authorized John Deere engine distributor or servicing dealer.
	Damaged valve retainers	Inspect retainer and retainer locks for excessive wear. See your authorized John Deere engine distributor or servicing dealer.
	Loose or worn rocker arms	Inspect rocker arms for wear. See your authorized John Deere engine distributor or servicing dealer.

Continued on next page

ZE59858,00000CB -19-30JUL13-5/12

Troubleshooting

Symptom	Problem	Solution
	Bent pushrods	Inspect pushrods for straightness and check contact ends for wear and damage. See your authorized John Deere engine distributor or servicing dealer.
	Broken valve springs	Inspect valve springs. See your authorized John Deere engine distributor or servicing dealer.
	Bent connecting rods	Inspect connecting rod and cap for damage. See your authorized John Deere engine distributor or servicing dealer.
	Worn flywheel	Inspect flywheel and ring gear for damage. See your authorized John Deere engine distributor or servicing dealer.
	Loose flywheel	Check flywheel mounting screw. See your authorized John Deere engine distributor or servicing dealer.
	Excessive piston to liner clearance	Check and adjust piston liner clearance. See your authorized John Deere engine distributor or servicing dealer.
	Excessive thrust bearing clearance	Check and adjust thrust bearing clearance. See your authorized John Deere engine distributor or servicing dealer.
	High oil viscosity	Drain engine oil and refill with correct viscosity engine oil
Turbocharger "Screams"	Leak in intake air system	Check air system for loose clamps, damaged tubes, charged air cooler leaks, and intake manifold gasket leaks; repair as required. See your authorized John Deere engine distributor or servicing dealer.

Continued on next page

ZE59858,00000CB -19-30JUL13-6/12

Troubleshooting

Symptom	Problem	Solution
<p>Turbocharger Noise or Vibration</p> <p><i>NOTE: Variable geometry turbocharger recycles after starting engine, causing a momentary revving sound in the engine. This is normal.</i></p> <p><i>Do not confuse the whine heard during run down with noise which indicates a bearing failure.</i></p>	Bearings not lubricated (insufficient oil pressure)	Determine cause of lack of lubrication; repair as required. See your authorized John Deere engine distributor or servicing dealer.
	Air leak in engine intake or exhaust manifold	Check intake and exhaust manifold gaskets and manifolds; repair as required. See your authorized John Deere engine distributor or servicing dealer.
	Improper clearance between turbine wheel and turbine housing	Inspect turbocharger; repair/replace as required. See your authorized John Deere engine distributor or servicing dealer.
	Broken blades (or other wheel failures)	Inspect turbocharger; repair/replace as required. See your authorized John Deere engine distributor or servicing dealer.
<p>Engine has reached Service Only Soot Level</p>	Auto Filter cleaning is disabled for an extended period of time	Enable exhaust filter cleaning.
	Frequent engine shut downs occurred while auto cleaning was in process	Let engine run for 30 min to clean the exhaust filter.
	Interlock switches are not properly set to allow DPF recovery/Regeneration to occur	Machine must be stationary (Parked). Engine speed must be above the minimum setpoint. Any PTO driven device must be shut off. Engine load must be stable.
<p>SCR High NOx Outlet</p>	DEF tank is low	Fill DEF tank with new DEF.
	Fluid other than DEF has been added to the DEF tank	Drain, flush, and fill DEF tank with new DEF. See Cleaning Diesel Exhaust Fluid (DEF) Tank in the Service As Required Section.
<p>Engine Emits White Smoke</p>	Engine compression too low	Determine cause of low compression and repair as required. See your authorized John Deere engine distributor or servicing dealer.
	Defective thermostat(s) (does not close)	Test thermostats; replace thermostats as required.

Continued on next page

ZE59858,00000CB -19-30JUL13-7/12

Troubleshooting

Symptom	Problem	Solution
	Coolant entering combustion chamber (failed cylinder head gasket or cracked cylinder head)	Repair or replace as required. See your authorized John Deere engine distributor or servicing dealer.
	Electronic Control System problem or basic engine problem	See your authorized John Deere engine distributor or servicing dealer.
	Improper type of fuel	Drain fuel and replace with proper grade and quality of fuel for operating condition.
	Poor fuel quality	Drain fuel and replace with proper grade and quality of fuel for operating condition.
	Low engine temperature	Warm up engine to normal operating temperature.
	Defective thermostat.	Remove and check thermostat.
	Defective fuel injectors	See your authorized John Deere engine distributor or servicing dealer.
Engine Emits Black, Gray or Blue Smoke	Engine overloaded	Reduce engine load.
	Engine burning oil	See your authorized John Deere engine distributor or servicing dealer.
	Air cleaner restricted or dirty	Replace air cleaner element as required.
	Electronic control system problem or basic engine problem	See your authorized John Deere engine distributor or servicing dealer.
	Exhaust filter is cracked or damaged	See your authorized John Deere engine distributor or servicing dealer.
	Improper type of fuel	Use proper fuel.
	Fuel injectors dirty	See your authorized John Deere engine distributor or servicing dealer.
	Electronic Control System problem or basic engine problem	See your authorized John Deere engine distributor or servicing dealer.
	Turbocharger not functioning properly	See your authorized John Deere engine distributor or servicing dealer.

Continued on next page

ZE59858,00000CB -19-30JUL13-8/12

Troubleshooting

Symptom	Problem	Solution
Engine Overheats	Air cleaner restricted or dirty	Replace air cleaner element as required.
	Lack of coolant in cooling system	Fill cooling system to proper level. Check radiator and hoses for loose connections or leaks.
	Low engine oil level	Check oil level. Add oil as required.
	Radiator core dirty	Clean cooling system as required.
	Cooling system needs flushing	Flush coolant system. (See Flushing And Refilling Cooling System in the Lubrication & Maintenance — 6000 Hours/72 Months Section.)
	Engine overloaded	Reduce engine load.
	Loose or defective fan belt	Check automatic belt tensioner and belts. Replace as required. (See Checking Tensioner Spring Tension in the Lubrication & Maintenance — 500 Hours/12 Months Section.)
	Defective or wrong type of thermostats	Test thermostat opening temperature, replace thermostats as required.
	Damaged cylinder head gasket	Replace cylinder head gasket. See your authorized John Deere engine distributor or servicing dealer.
	Leak at cylinder head gasket	Replace cylinder head gasket. See your authorized John Deere engine distributor or servicing dealer.
	Defective coolant pump	Replace coolant pump. See your authorized John Deere engine distributor or servicing dealer.
	Defective radiator cap	Replace radiator cap as required.
	Defective temperature gauge or sender	Check coolant temperature with thermometer and replace, if necessary.
Coolant Temperature Below Normal	Incorrect grade of fuel	Use correct grade of fuel.
	Defective thermostat(s)	Test thermostats, replace thermostats as required.

Continued on next page

ZE59858,00000CB -19-30JUL13-9/12

Troubleshooting

Symptom	Problem	Solution
	Defective temperature gauge or temperature sender	Check gauge, sender, and connections.
Coolant in Crankcase	Cylinder head gasket defective	Replace cylinder head gasket. See your authorized John Deere engine distributor or servicing dealer.
	Cylinder head or block cracked	Locate crack, repair/replace components as required. See your authorized John Deere engine distributor or servicing dealer.
	Cylinder liner seals leaking	Remove and inspect cylinder liners. See your authorized John Deere engine distributor or servicing dealer.
	Pitted cylinder liners	Remove and inspect cylinder liners. See your authorized John Deere engine distributor or servicing dealer.
	Leaking oil cooler	Pressure test oil cooler, repair/replace as required. See your authorized John Deere engine distributor or servicing dealer.
	Defective oil cooler O-rings	Remove and inspect oil cooler O-rings, replace as required. See your authorized John Deere engine distributor or servicing dealer.
	EGR cooler system leaking	Pressure test EGR cooler system, repair/replace as required. See your authorized John Deere engine distributor or servicing dealer.
	Faulty coolant pump seal; weep hole plugged; coolant leaking through bearing	Replace coolant pump seals. See your authorized John Deere engine distributor or servicing dealer.
Low Oil Pressure	Low crankcase oil level	Fill crankcase to proper oil level.
	Faulty pressure sensor	Replace sensor. See your authorized John Deere engine distributor or servicing dealer.
	Restricted oil cooler or filter	Remove and inspect oil cooler. See your authorized John Deere engine distributor or servicing dealer.

Continued on next page

ZE59858,00000CB -19-30JUL13-10/12

Troubleshooting

Symptom	Problem	Solution
	Excessive oil temperature	Remove and inspect oil cooler. See your authorized John Deere engine distributor or servicing dealer.
	Defective oil pump	Remove and inspect oil pump. See your authorized John Deere engine distributor or servicing dealer.
	Incorrect oil	Drain crankcase and refill with correct oil.
	Oil pressure regulating valve failure	Remove and inspect oil pressure regulating valve. See your authorized John Deere engine distributor or servicing dealer.
	Restricted oil pump screen or cracked pick-up tube	Remove oil pan and clean screen/replace pick-up tube.
	Excessive main or connecting rod bearing clearance	Determine bearing clearance. See your authorized John Deere engine distributor or servicing dealer.
	Crankcase oil level too high	Check engine oil level and drain as necessary.
High Oil Pressure	Improper oil classification	Drain crankcase and refill with correct oil.
	Faulty pressure sensor	Replace sensor. See your authorized John Deere engine distributor or servicing dealer.
	Oil pressure regulating valve failure	Remove and inspect oil pressure regulating valve. See your authorized John Deere engine distributor or servicing dealer.
	Stuck or damaged filter bypass valve	Remove and inspect filter bypass valve. See your authorized John Deere engine distributor or servicing dealer.
	Stuck or damaged oil cooler bypass valve	Remove and inspect oil cooler bypass valve. See your authorized John Deere engine distributor or servicing dealer.
Excessive Oil Consumption	Too low viscosity crankcase oil	Drain crankcase and refill with correct viscosity oil.

Continued on next page

ZE59858.00000CB -19-30JUL13-11/12

Troubleshooting

Symptom	Problem	Solution
	Crankcase oil level too high	Drain oil until oil level is correct.
	External oil leak(s)	Determine source of oil leak(s) and repair as required.
	Excessive oil pressure	See High Oil Pressure
	Oil control rings not seated	See your authorized John Deere engine distributor or servicing dealer.
	Oil control rings worn or broken	Replace piston rings. See your authorized John Deere engine distributor or servicing dealer.
	Restricted crankcase vent tube	Clean vent tube, verify that crankcase oil level is not too high.
	Defective turbocharger	See your authorized John Deere engine distributor or servicing dealer.
	Scored cylinder liners or pistons	Remove and inspect cylinders and liners; replace as required. See your authorized John Deere engine distributor or servicing dealer.
	Worn valve guides or stems	Inspect and measure valve stems and valve guides; repair as required. See your authorized John Deere engine distributor or servicing dealer.
	Piston ring grooves excessively worn	Remove and inspect pistons. See your authorized John Deere engine distributor or servicing dealer.
	Piston rings sticking in ring grooves	Remove and inspect pistons. See your authorized John Deere engine distributor or servicing dealer.
	Insufficient piston ring tension	Remove and inspect pistons. See your authorized John Deere engine distributor or servicing dealer.
	Piston ring gaps not staggered	Remove and inspect pistons. See your authorized John Deere engine distributor or servicing dealer.
	Front and/or rear crankshaft oil seal faulty	Replace oil seals. See your authorized John Deere engine distributor or servicing dealer.

ZE59858,00000CB -19-30JUL13-12/12

Troubleshooting

Symptom	Problem	Solution
Undercharged Electrical System	Excessive electrical load from added accessories	Remove accessories or install higher output alternator. See your authorized John Deere engine distributor or servicing dealer.
	Excessive engine idling	Increase engine rpm when heavy electrical load is used.
	Poor electrical connections on battery, ground strap, starter, or alternator	Inspect and clean as necessary.
	Defective battery	Test batteries.
	Defective alternator	Test charging system.
Battery Used Too Much Water	Cracked battery case	Check for moisture and replace as necessary.
	Defective battery	Test battery.
	Battery charging rate too high	Test charging system.
Batteries Will Not Charge	Loose or corroded connections	Clean and tighten connections.
	Sulfated or worn-out batteries	Replace batteries.
	Stretched belt or defective belt tensioner	Adjust belt tension or replace belts.
Starter and Hourmeter Functions; Rest of Electrical System Does Not Function	Blown fuse	Replace fuse.
	Entire Electrical System Does Not Function	
	Faulty battery connection	Clean and tighten connections.
	Sulfated or worn-out batteries	Replace batteries.
	Blown fuse	Replace fuse.

ZE59858,00000CB -19-30JUL13-13/12

Precautions for Electrical System When Steam Cleaning Engine

IMPORTANT: Do not steam clean any electrical or electronic components while steam cleaning the engine as it could damage sensitive parts.

RK80614,0000053 -19-16OCT12-1/1

Engine Wiring Harness Layout

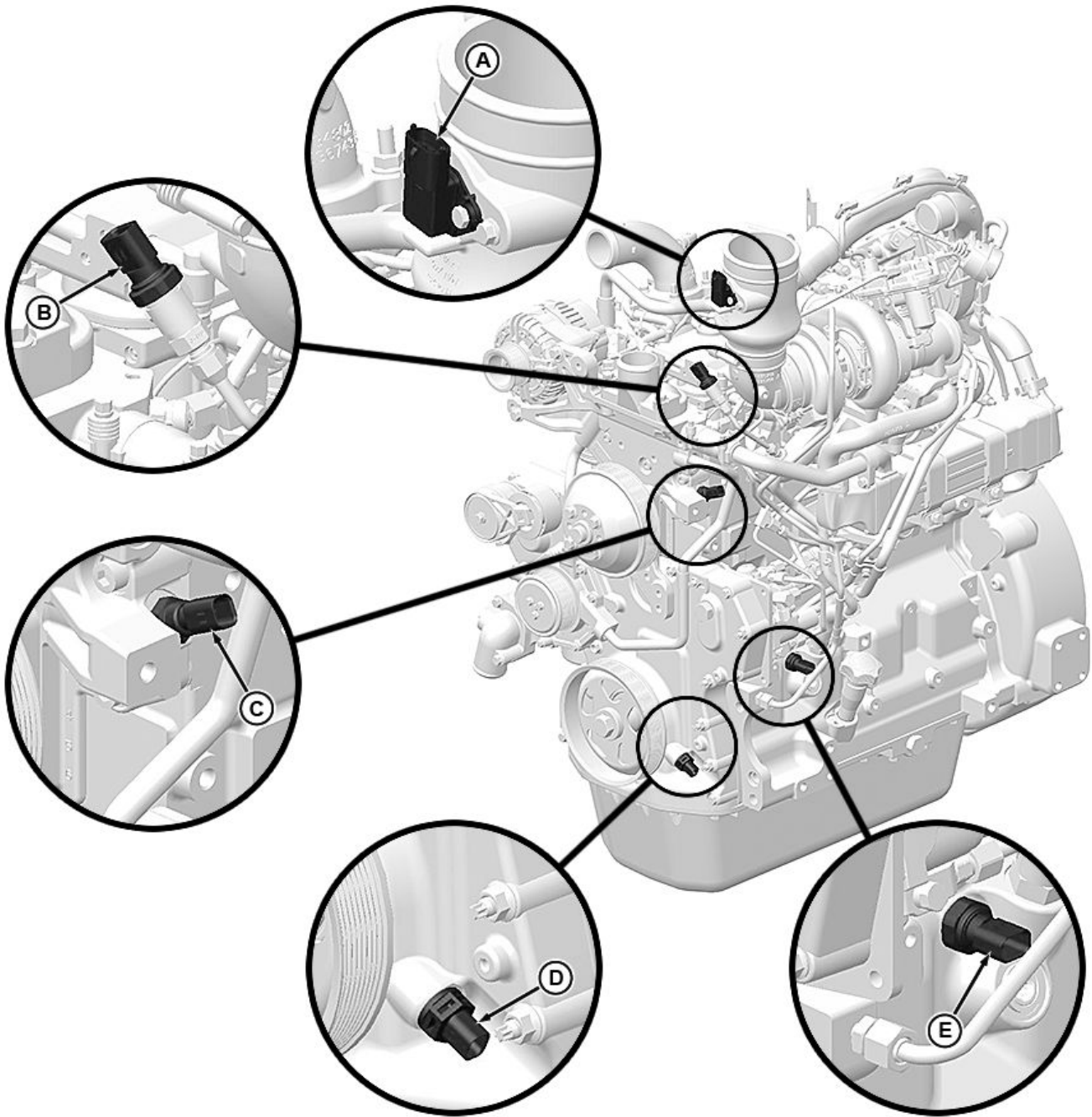

RG25766—UN—08MAY14

A—Intake Air Sensor
B—Exhaust Manifold Pressure Sensor

C—Engine Coolant Temperature Sensor
D—Crankshaft Position Sensor

E—Engine Oil Pressure Sensor

Continued on next page

ZE59858,0000027 -19-30JUL14-1/4

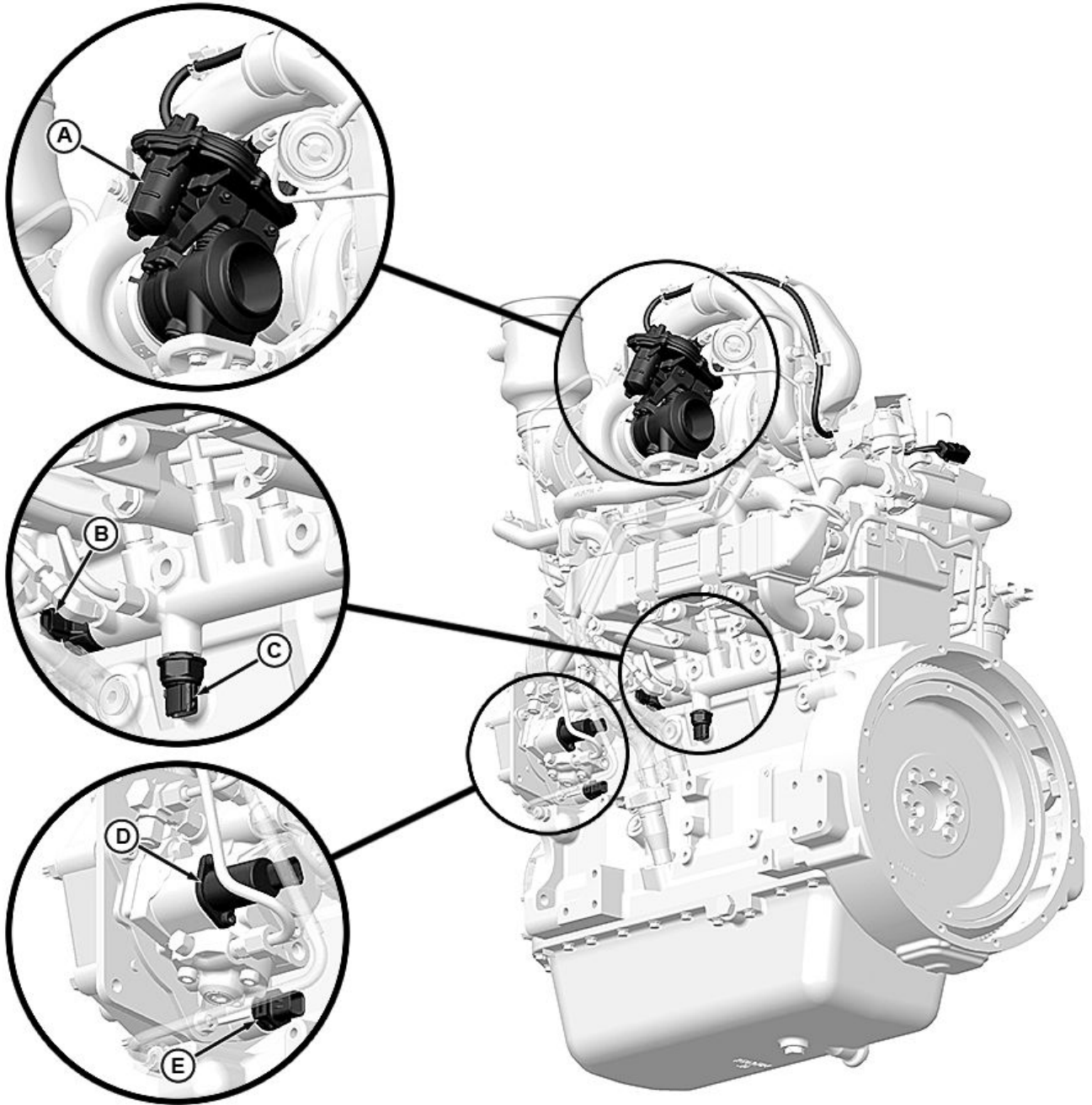

A—Exhaust Throttle Actuator
B—Fuel Rail Pressure Relief Valve

C—Fuel Rail Pressure Sensor
D—Suction Control Valve

E—Camshaft Position Sensor

Continued on next page

ZE59858,0000027 -19-30JUL14-2/4

RG25768 —UN—08MAY14

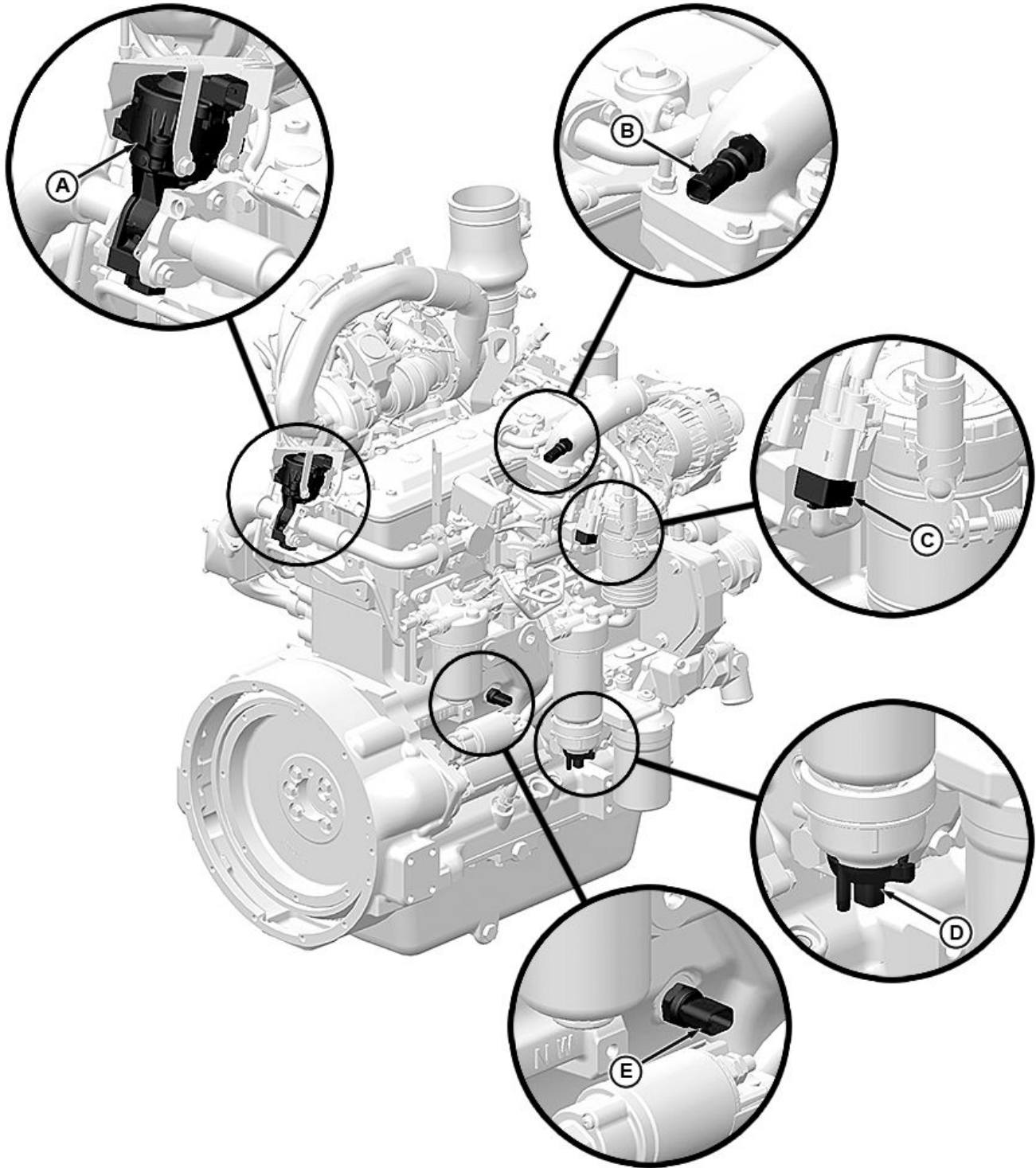

A—EGR Valve
B—Charge Air Cooler Outlet
Temperature Sensor

C—Cold Start Aid Relay
D—Water-In-Fuel (WIF) Sensor

E—Crankcase Pressure Sensor

Continued on next page

ZE59858.0000027 -19-30JUL14-3/4

RG25769 —UN—08MAY14

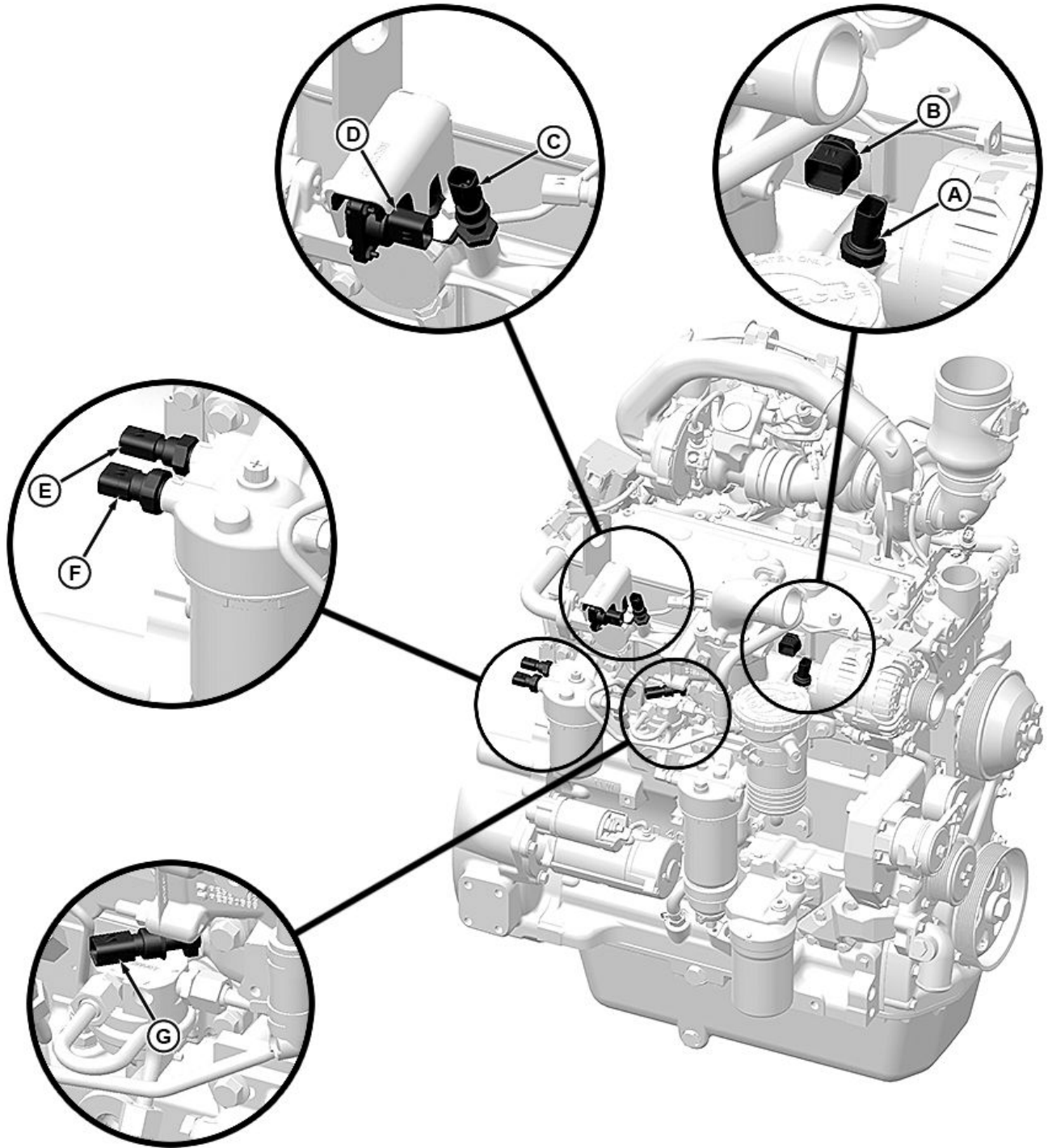

- | | | |
|--|---------------------------------|--|
| A—Manifold Air Pressure Sensor | C—EGR Temperature Sensor | F—Low-Pressure Fuel Pressure Sensor |
| B—Fuel Injector Harness Connector | D—EGR Flow Sensor | G—Manifold Air Temperature Sensor |
| E—Fuel Temperature Sensor | | |

RG25770 — UN — 08MAY14

ZE59858,0000027 -19-30JUL14-4/4

Precautions For Welding

Remove paint before welding or heating (see safety section in this manual for more information on paint removal and high-pressure lines).

⚠ CAUTION: Avoid potentially toxic fumes and dust. Hazardous fumes can be generated when paint is heated by welding, soldering, or using a torch. Do all work outside or in a well ventilated area. Dispose of paint and solvent properly. If you sand or grind paint, avoid breathing the dust by wearing an approved respirator. If you use solvent or paint stripper, remove with soap and water before welding. Remove solvent or paint stripper containers and other flammable material from area before welding. Allow fumes to disperse at least 15 minutes before welding or heating.

IMPORTANT: Welding on the engine is **NOT ALLOWED**. If welding must be performed on the machine, follow these precautions.

IMPORTANT: High currents or electrostatic discharge into electronic components from welding may cause permanent damage.

1. Remove paint from the area to be welded and ground cable clamp location.



TS953—UN—15MAY90

2. Disconnect the negative (-) battery cable(s).
3. Disconnect the positive (+) battery cable(s).
4. Disconnect connectors from ECU.
5. Clear or move any wiring harness sections away from the welding area.
6. Never connect the welder ground to any engine component or engine driven components that may be connected to the engine.
7. Reconnect all previously disconnected components.

RK80614,0000055 -19-08JUL20-1/1

4.5 L Wiring Diagram 1

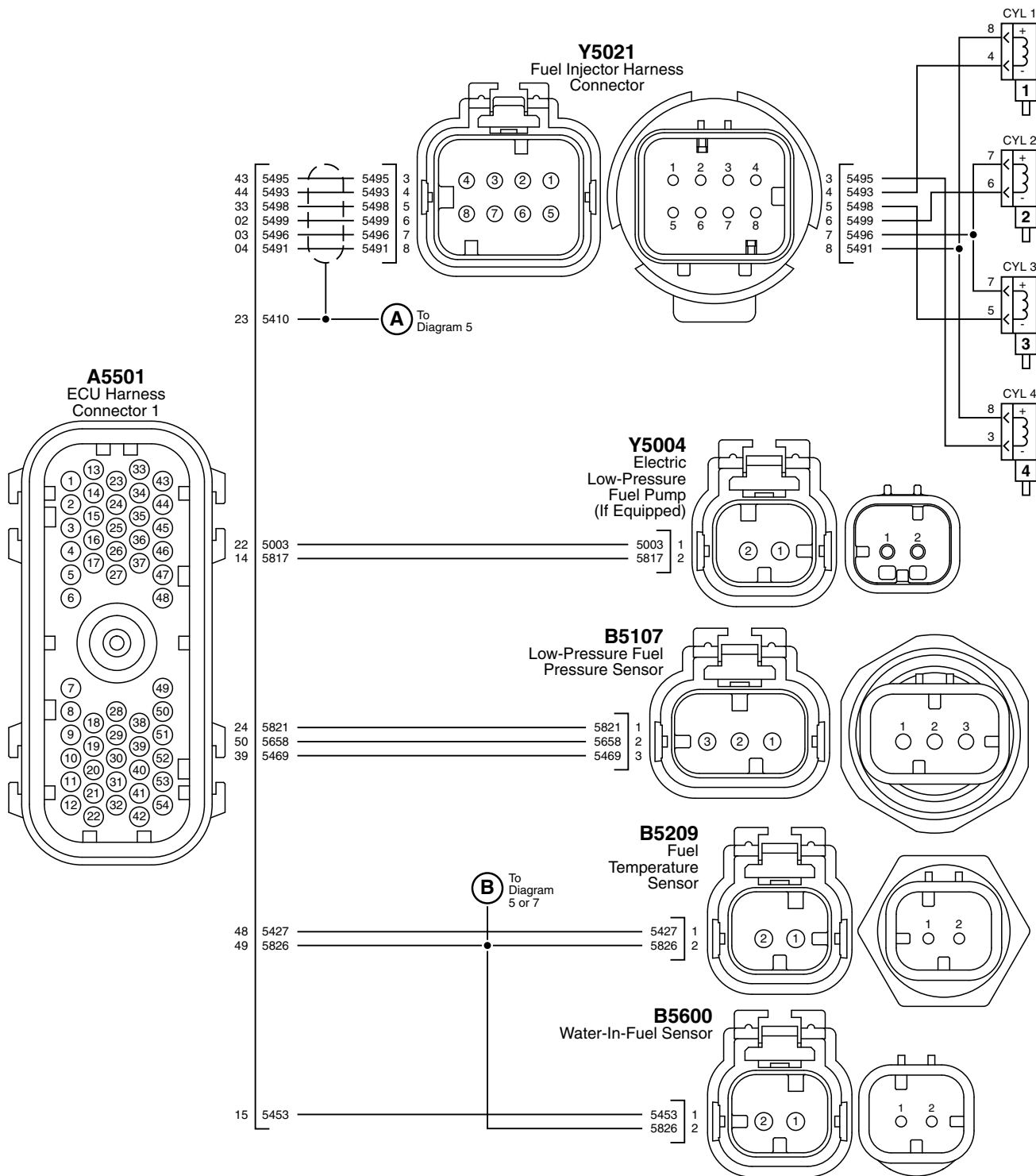

RG26327 -UN-18AUG14

Continued on next page

AT89373.0000013 -19-18AUG14-1/2

Troubleshooting

A— To 4.5 L Wiring Diagram 5	A5501-22— [5003 Orange] Low-Pressure Fuel Pump Power	A5501-44— [5493 Orange] Injector #1 Pulse	B5600— Water-In-Fuel Sensor
A5501— ECU Harness Connector 1	A5501-23— [5410 Black] Wiring Shield	A5501-48— [5427 Violet] Fuel Temperature Sensor Signal	CYL 1— Cylinder 1
A5501-02— [5499 White] Injector #2 Pulse	A5501-24— [5821 Brown] 5 V Sensor Supply #6b Positive	A5501-49— [5826 Blue] Sensor Return #10	CYL 2— Cylinder 2
A5501-03— [5496 Blue] Injector #2 and #3 Power	A5501-33— [5498 Gray] Injector #3 Pulse	A5501-50— [5658 Gray] Sensor Return #6	CYL 3— Cylinder 3
A5501-04— [5491 Brown] Injector #1 and #4 Power	A5501-39— [5469 White] Low-Pressure Fuel Pressure Sensor Signal	B— To 4.5 L Wiring Diagram 5 or 4.5 L Wiring Diagram 7	CYL 4— Cylinder 4
A5501-14— [5817 Violet] Low-Pressure Fuel Pump Return	A5501-43— [5495 Green] Injector #4 Pulse	B5107— Low-Pressure Fuel Pressure Sensor	Y5004— Electric Low-Pressure Fuel Pump (If Equipped)
A5501-15— [5453 Orange] Water-In-Fuel Sensor Signal		B5209— Fuel Temperature Sensor	Y5021— Fuel Injector Harness Connector

AT89373,0000013 -19-18AUG14-2/2

4.5 L Wiring Diagram 2

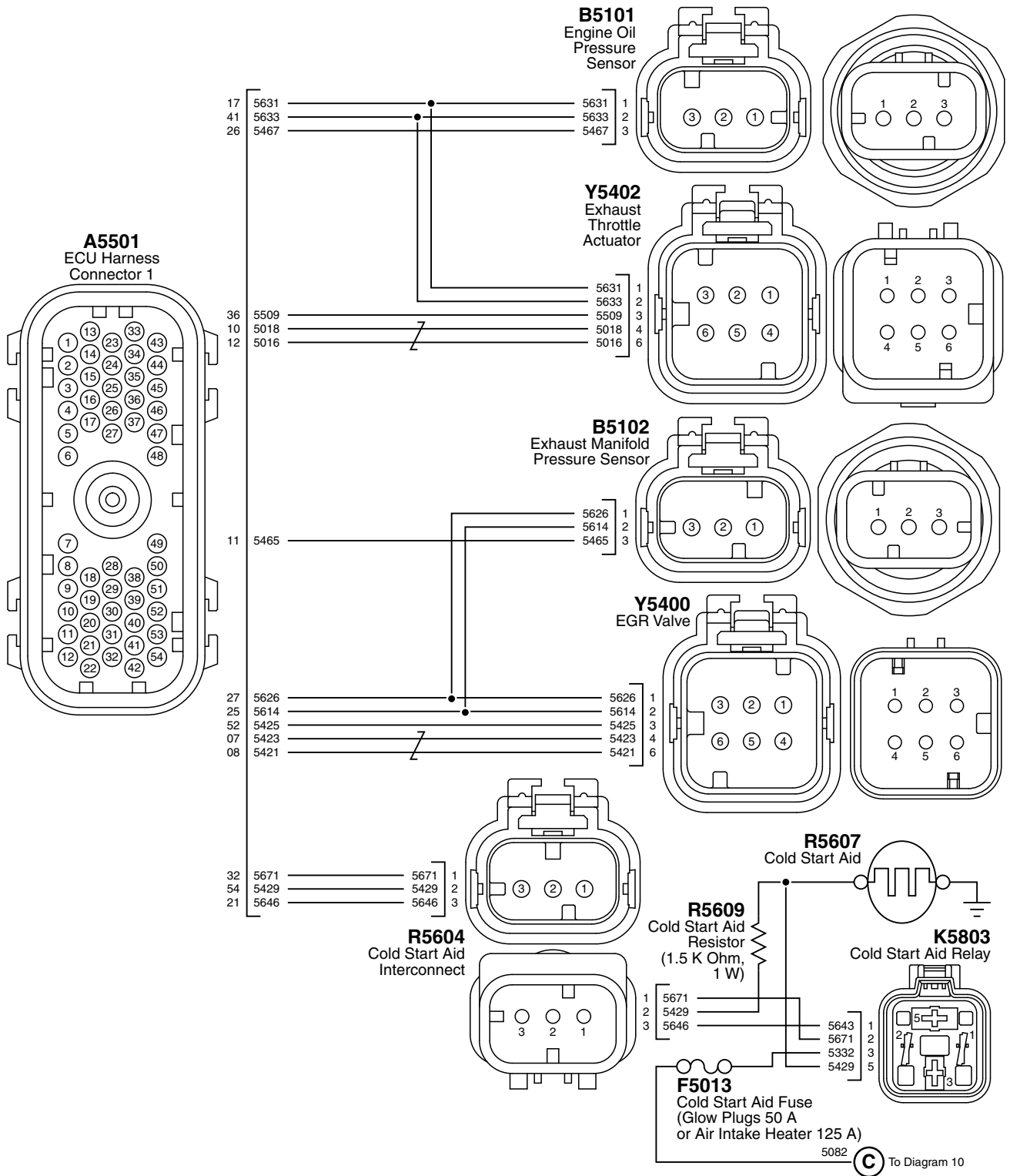

RG26328—UN—18AUG14

Continued on next page

AT89373.0000014 -19-18AUG14-1/2

Troubleshooting

A5501— ECU Harness Connector 1	A5501-17— [5631 Brown] 5 V Sensor Supply #3 Positive	A5501-41— [5633 Orange] 5 V Sensor Supply #3 Return	K5803— Cold Start Aid Relay
A5501-07— [5423 Orange] EGR Valve Drive Negative	A5501-21— [5646 Blue] Sensor Return #1	A5501-52— [5425 Green] EGR Valve Position Sensor Signal	R5604— Cold Start Aid Interconnect
A5501-08— [5421 Brown] EGR Valve Drive Positive	A5501-25— [5614 Yellow] 5 V Sensor Supply #6 Return	A5501-54— [5429 White] Cold Start Aid Signal	R5607— Cold Start Aid Resistor (1.5 K Ohm, 1 W)
A5501-10— [5018 Gray] Exhaust Throttle Actuator Drive Negative	A5501-26— [5467 Violet] Engine Oil Pressure Sensor Signal	C— [5082 Red] Battery Power Positive To 4.5 L Wiring Diagram 10	Y5400— EGR Valve
A5501-11— [5465 Green] Exhaust Manifold Pressure Sensor Signal	A5501-27— [5626 Blue] 5 V Sensor Supply #6a Positive	B5101— Engine Oil Pressure Sensor	Y5402— Exhaust Throttle Actuator
A5501-12— [5016 Blue] Exhaust Throttle Actuator Drive Positive	A5501-32— [5671 Brown] Cold Start Aid Drive Positive	B5102— Exhaust Manifold Pressure Sensor	
	A5501-36— [5509 White] Exhaust Throttle Actuator Position Signal	F5013— Cold Start Aid Fuse (Glow Plugs 50 A or Air Intake Heater 125 A)	

AT89373,0000014 -19-18AUG14-2/2

4.5 L Wiring Diagram 3

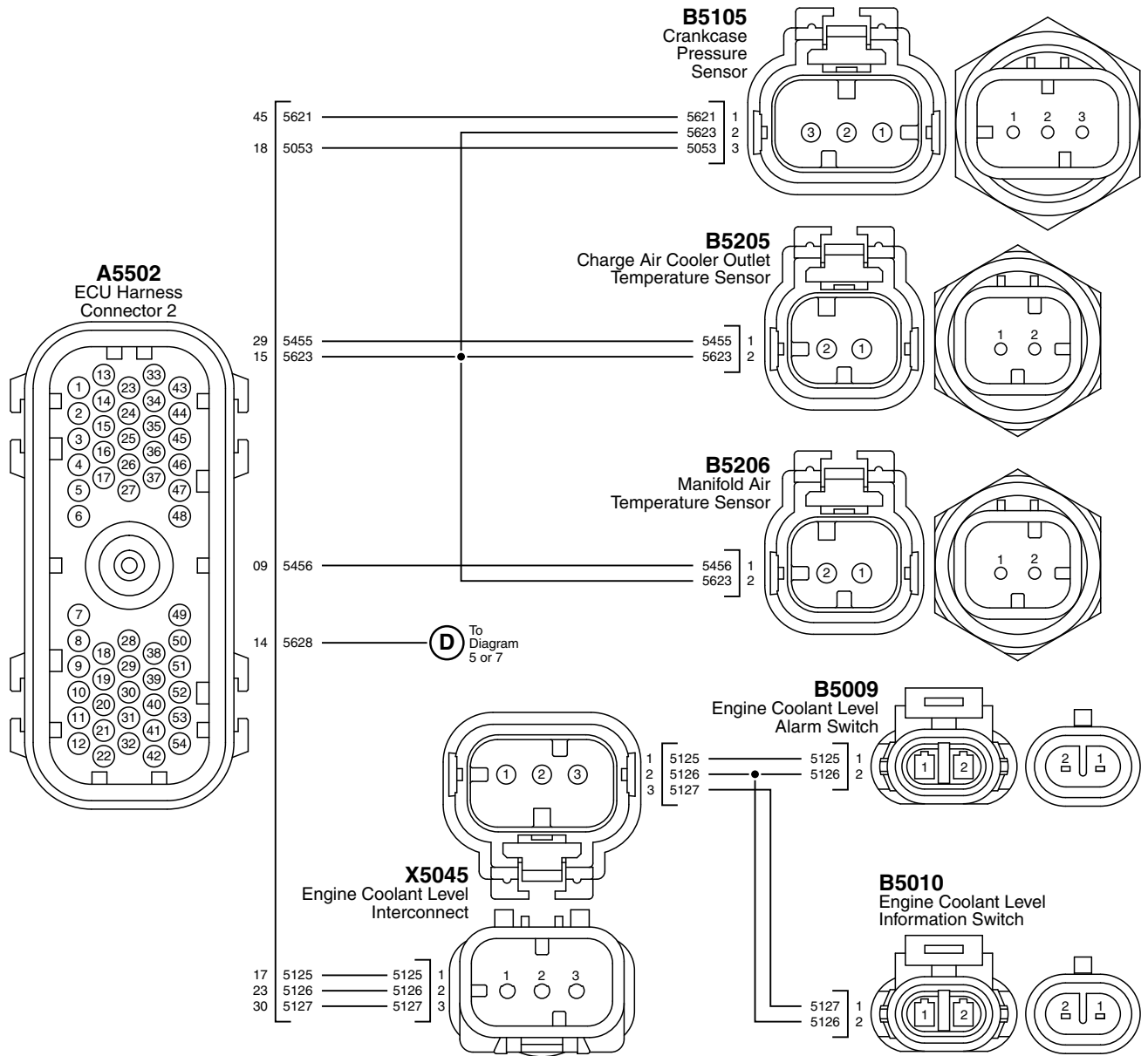

- | | | | |
|---|---|--|--|
| A5502 — ECU Harness Connector 2 | A5502-18 — [5053 Orange] Crankcase Pressure Sensor Signal | A5502-45 — [5621 Brown] 5 V Sensor Supply #2 | B5206 — Manifold Air Temperature Sensor |
| A5502-09 — [5456 Blue] Manifold Air Temperature Sensor Signal | A5502-23 — [5126 Blue] Sensor Return #7 | B5009 — Engine Coolant Level Alarm Switch | D — To 4.5 L Wiring Diagram 5 or 4.5 L Wiring Diagram 7 |
| A5502-14 — [5628 Gray] Sensor Return #2 | A5502-29 — [5455 Green] Charge Air Cooler Outlet Temperature Sensor Signal | B5010 — Engine Coolant Level Information Switch | X5045 — Engine Coolant Level Interconnect |
| A5502-15 — [5623 Orange] 5 V Sensor Supply #2 Return | A5502-30 — [5127 Violet] Engine Coolant Level Information Switch Signal | B5105 — Crankcase Pressure Sensor | |
| A5502-17 — [5125 Green] Engine Coolant Level Alarm Switch Signal | | B5205 — Charge Air Cooler Outlet Temperature Sensor | |

AT89373.0000015 -19-18AUG14-1/1

RG26329—UN—18AUG14

4.5 L Wiring Diagram 4

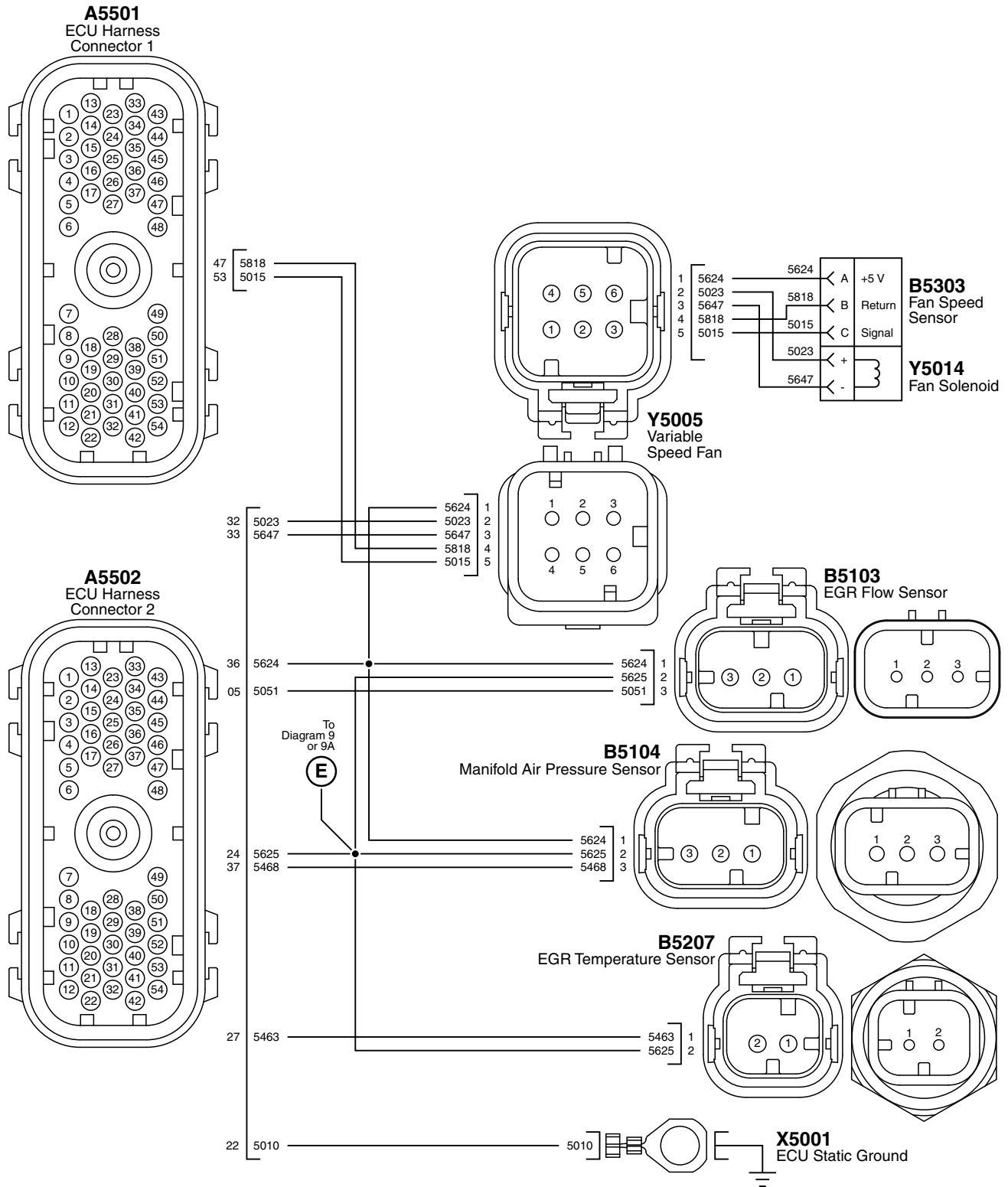

RG26330A —UN—27APR16

Continued on next page

AT89373.0000016 -19-27APR16-1/2

Troubleshooting

A5501— ECU Harness Connector 1	A5502-24— [5625 Green] 5 V Sensor Supply #7 Return	A5502-36— [5624 Yellow] 5 V Sensor Supply #7 Positive	E— To 4.5 L Wiring Diagram 9 or 4.5 L Wiring Diagram 9A
A5501-47— [5818 Gray] Fan Speed Return	A5502-27— [5463 Orange] EGR Temperature Sensor Signal	A5502-37— [5468 Gray] Manifold Air Pressure Sensor Signal	X5001— ECU Static Ground
A5501-53— [5015 Green] Fan Speed Sensor Signal	A5502-32— [5023 Orange] Variable Speed Fan Drive Positive	B5103— EGR Flow Sensor	Y5005— Variable Speed Fan
A5502— ECU Harness Connector 2	A5502-33— [5647 Violet] Variable Speed Fan Drive Negative	B5104— Manifold Air Pressure Sensor	Y5014— Fan Solenoid
A5502-05— [5051 Brown] EGR Flow Sensor Signal		B5207— EGR Temperature Sensor	
A5502-22— [5010 Black] ECU Static Ground		B5303— Fan Speed Sensor	

AT89373.0000016 -19-27APR16-2/2

4.5 L Wiring Diagram 5

AA Wiring Diagram For High Mount
Dual Turbocharged Engines
Or Single Turbocharged Engines

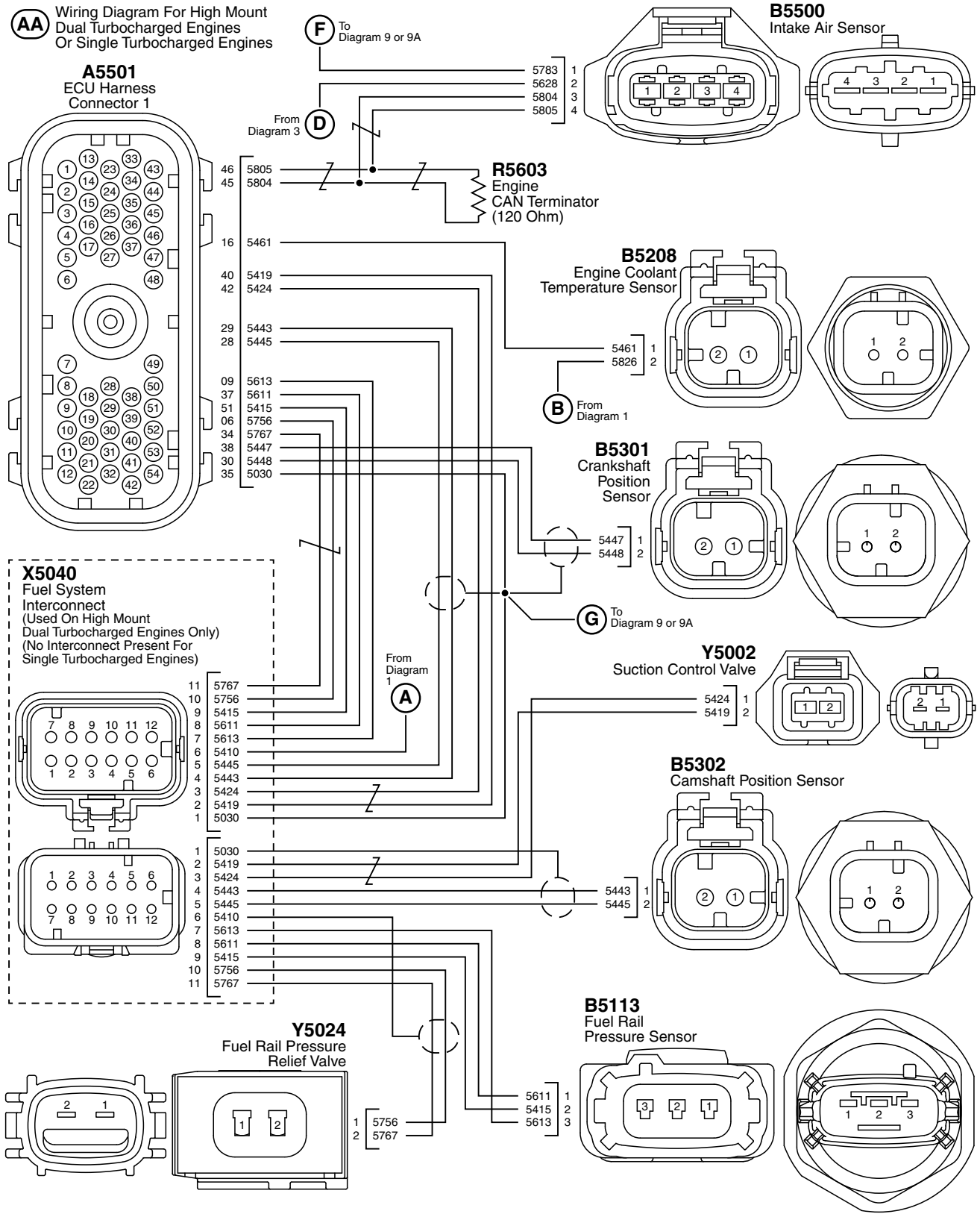

RG26331A —UN—27APR16

Continued on next page

AT89373.0000017 -19-27APR16-1/2

Troubleshooting

A— [5410 Black] Wiring Shield From 4.5 L Wiring Diagram 1	A5501-30— [5448 Gray] Crankshaft Position Sensor Return	A5501-46— [5805 Green] Engine CAN Low	G— To 4.5 L Wiring Diagram 9 or 4.5 L Wiring Diagram 9A
AA— Wiring Diagram For High Mount Dual Turbocharged Engines Or Single Turbocharged Engines	A5501-34— [5767 Violet] Fuel Rail Pressure Relief Valve Drive Negative	A5501-51— [5415 Green] Fuel Rail Pressure Sensor Signal	R5603— Engine CAN Terminator (120 Ohm)
A5501— ECU Harness Connector 1	A5501-35— [5030 Black] Wiring Shield	B— [5826 Blue] Sensor Return #10 From 4.5 L Wiring Diagram 1	X5040— Fuel System Interconnect (Used On High Mount Dual Turbocharged Engines Only) (No Interconnect Present For Single Turbocharged Engines)
A5501-06— [5756 Blue] Fuel Rail Pressure Relief Valve Drive Positive	A5501-37— [5611 Brown] 5 V Sensor Supply #1 Positive	B5208— Engine Coolant Temperature Sensor	Y5002— Suction Control Valve
A5501-09— [5613 Orange] 5 V Sensor Supply #1 Return	A5501-38— [5447 Violet] Crankshaft Position Sensor Signal	B5113— Fuel Rail Pressure Sensor	Y5024— Fuel Rail Pressure Relief Valve
A5501-16— [5461 Brown] Engine Coolant Temperature Sensor Signal	A5501-40— [5419 White] Suction Control Valve Drive Negative	B5301— Crankshaft Position Sensor	
A5501-28— [5445 Green] Camshaft Position Sensor Signal	A5501-42— [5424 Yellow] Suction Control Valve Drive Positive	B5302— Camshaft Position Sensor	
A5501-29— [5443 Orange] Camshaft Position Sensor Return	A5501-45— [5804 Yellow] Engine CAN High	B5500— Intake Air Sensor	
		D— [5628 Gray] Sensor Return #2 From 4.5 L Wiring Diagram 3	
		F— [5783 Orange] 12 V Sensor Supply To 4.5 L Wiring Diagram 9 or 4.5 L Wiring Diagram 9A	

AT89373.0000017 -19-27APR16-2/2

4.5 L Wiring Diagram 6

A5501
ECU Harness
Connector 1

BB Wiring Diagram
For Dual Turbocharged Engines
With A Low Mount Fixed Turbocharger

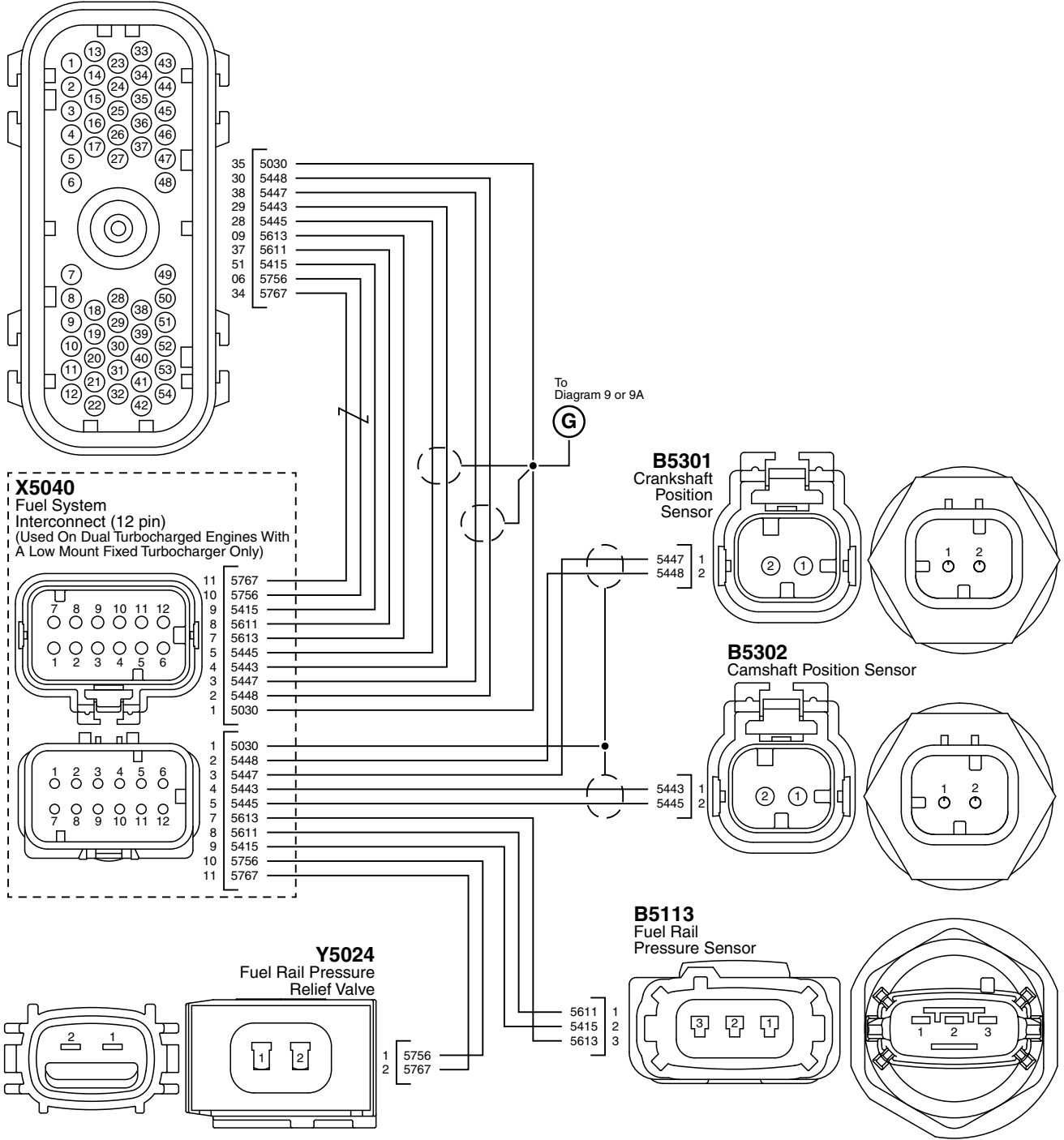

RG26332A — UN—27APR16

Continued on next page

AT89373.0000018 -19-27APR16-1/2

Troubleshooting

A5501— ECU Harness Connector 1	A5501-30— [5448 Gray] Crankshaft Position Sensor Return	A5501-51— [5415 Green] Fuel Rail Pressure Sensor Signal	X5040— Fuel System Interconnect (12 pin) (Used On Dual Turbocharged Engines With A Low Mount Fixed Turbocharger Only)
A5501-06— [5756 Blue] Fuel Rail Pressure Relief Valve Drive Positive	A5501-34— [5767 Violet] Fuel Rail Pressure Relief Valve Drive Negative	BB— Wiring Diagram For Dual Turbocharged Engines With A Low Mount Fixed Turbocharger	
A5501-09— [5613 Orange] 5 V Sensor Supply #1 Return	A5501-35— [5030 Black] Wiring Shield	B5113— Fuel Rail Pressure Sensor	Y5024— Fuel Rail Pressure Relief Valve
A5501-28— [5445 Green] Camshaft Position Sensor Signal	A5501-37— [5611 Brown] 5 V Sensor Supply #1 Positive	B5301— Crankshaft Position Sensor	
A5501-29— [5443 Orange] Camshaft Position Sensor Return	A5501-38— [5447 Violet] Crankshaft Position Sensor Signal	B5302— Camshaft Position Sensor	
		G— To 4.5 L Wiring Diagram 9 or 4.5 L Wiring Diagram 9A	

AT89373.0000018 -19-27APR16-2/2

4.5 L Wiring Diagram 7

A5501
ECU Harness
Connector 1

BB Wiring Diagram
For Dual Turbocharged Engines
With A Low Mount Fixed Turbocharger

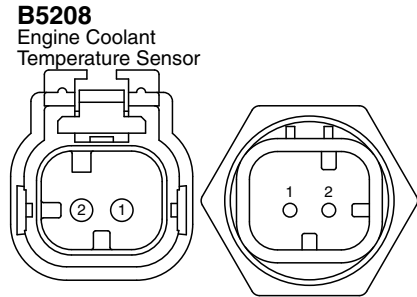
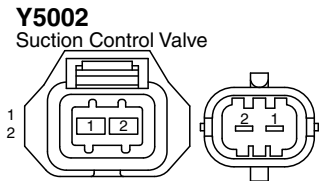
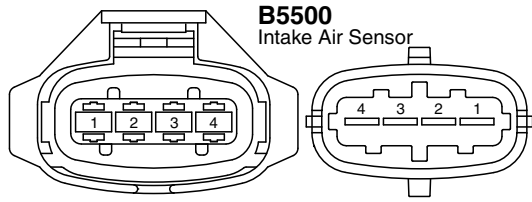
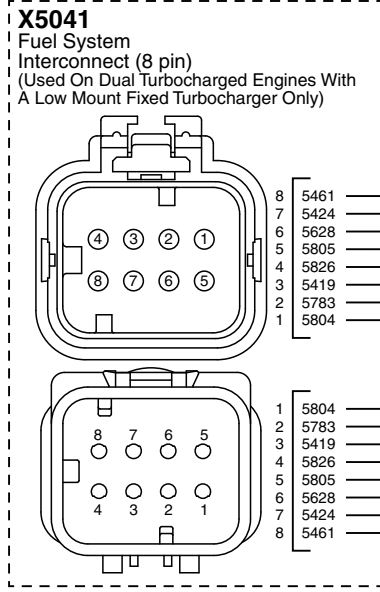
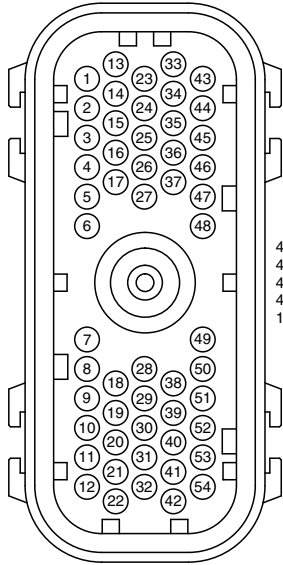

- A5501**— ECU Harness Connector 1
- A5501-16**— [5461 Brown] Engine Coolant Temperature Sensor Signal
- A5501-40**— [5419 White] Suction Control Valve Drive Negative
- A5501-42**— [5424 Yellow] Suction Control Valve Drive Positive
- A5501-45**— [5804 Yellow] Engine CAN High
- A5501-46**— [5805 Green] Engine CAN Low
- B**— [5826 Blue] Sensor Return #10 From 4.5 L Wiring Diagram 1
- BB**— Wiring Diagram For Dual Turbocharged Engines With A Low Mount Fixed Turbocharger
- B5208**— Engine Coolant Temperature Sensor
- B5500**— Intake Air Sensor
- D**— [5628 Gray] Sensor Return #2 From 4.5 L Wiring Diagram 3
- F**— [5783 Orange] 12 V Sensor Supply To 4.5 L Wiring Diagram 9 or 4.5 L Wiring Diagram 9A
- R5603**— Engine CAN Terminator (120 Ohm)
- X5041**— Fuel System Interconnect (8 pin) (Used On Dual Turbocharged Engines With A Low Mount Fixed Turbocharger Only)
- Y5002**— Suction Control Valve

RG26333A —UN—27APR16

4.5 L Wiring Diagram 8

CC Aftertreatment Option Continued On Diagram 9

X5037
DEF Dosing Unit
Interconnect

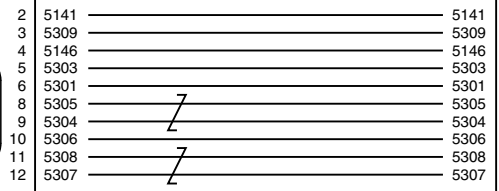
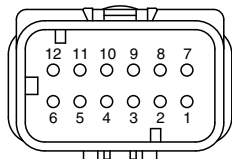

B5501
DEF Dosing Unit

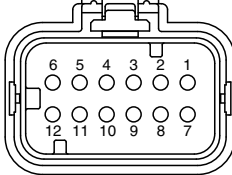
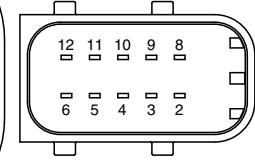
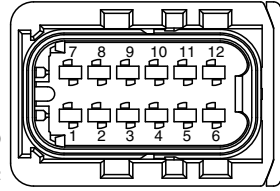

A5502
ECU Harness
Connector 2

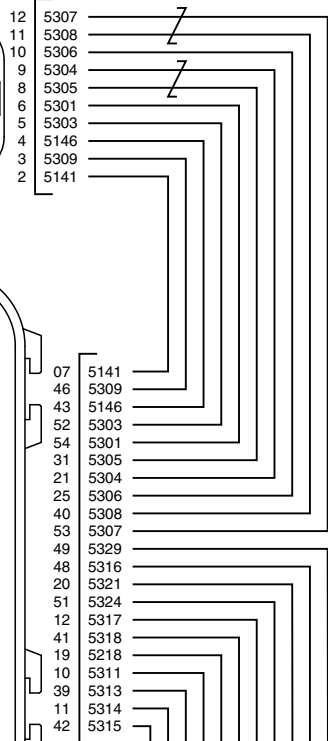
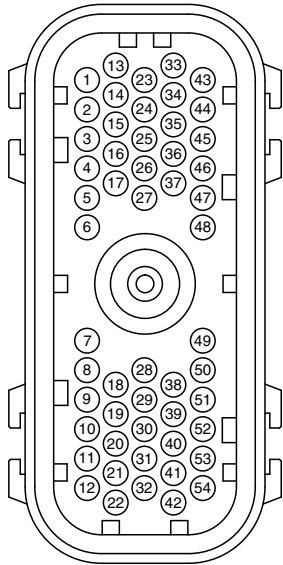

A5507
DEF Tank Header
Assembly

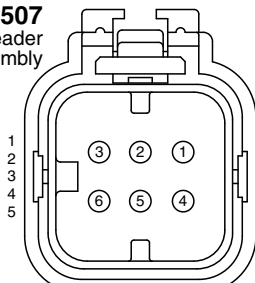

Y5019
DEF Tank
Coolant
Control Valve

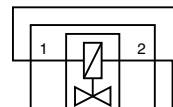

B5211
DEF Tank Fluid
Temperature
Sensor

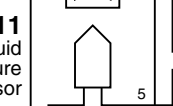

B5601
DEF Tank Fluid
Level Sensor

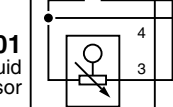

E5603
DEF Dosing Unit
Return Line Heater

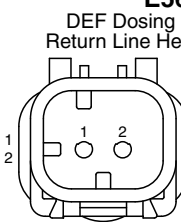

E5601
DEF Dosing Unit
Pressure Line Heater

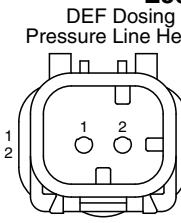

E5602
DEF Dosing Unit
Supply Line Heater

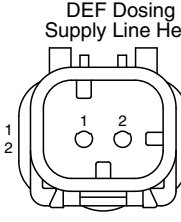

X5038
DEF Dosing System
Interconnect

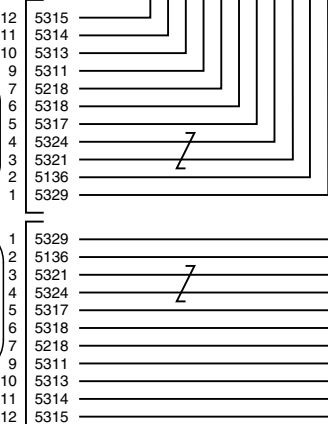
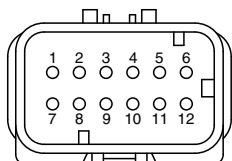

Continued on next page

AT89373.000001A -19-27APR16-1/2

RG26334A -UN-27APR16

Troubleshooting

A5502— ECU Harness Connector 2	A5502-25— [5306 Blue] DEF Dosing Unit Pump Position Signal	A5502-48— [5136 Blue] Sensor Return #14	B5601— DEF Tank Fluid Level Sensor
A5502-07— [5141 Brown] 5 V Sensor Supply #8b Positive	A5502-31— [5305 Green] DEF Dosing Unit Pump Drive Negative	A5502-49— [5329 White] DEF Tank Fluid Level Sensor Signal	CC— Aftertreatment Option Continued On 4.5 L Wiring Diagram 9
A5502-10— [5311 Brown] DEF Dosing Unit Pressure Line Heater Positive	A5502-39— [5313 Orange] DEF Dosing Unit Pressure Line Heater Negative	A5502-51— [5324 Yellow] DEF Coolant Control Valve Drive Negative	E5601— DEF Dosing Unit Pressure Line Heater
A5502-11— [5314 Yellow] DEF Dosing Unit Supply Line Heater Positive	A5502-40— [5308 Gray] DEF Dosing Unit Reversing Valve Drive Negative	A5502-52— [5303 Orange] DEF Dosing Unit Heater Negative	E5602— DEF Dosing Unit Supply Line Heater
A5502-12— [5317 Violet] DEF Dosing Unit Return Line Heater Positive	A5502-41— [5318 Gray] DEF Dosing Unit Return Line Heater Negative	A5502-53— [5307 Violet] DEF Dosing Unit Reversing Valve Drive Positive	E5603— DEF Dosing Unit Return Line Heater
A5502-19— [5218 Gray] DEF Tank Fluid Temperature Signal	A5502-42— [5315 Green] DEF Dosing Unit Supply Line Heater Negative	A5502-54— [5301 Brown] DEF Dosing Unit Heater Positive	X5037— DEF Dosing Unit Interconnect
A5502-20— [5321 Brown] DEF Coolant Control Valve Drive Positive	A5502-43— [5146 Blue] Sensor Return #13	A5507— DEF Tank Header Assembly	X5038— DEF Dosing System Interconnect
A5502-21— [5304 Yellow] DEF Dosing Unit Pump Drive Positive	A5502-46— [5309 White] DEF Dosing Unit Pressure Sensor Signal	B5211— DEF Tank Fluid Temperature Sensor	Y5019— DEF Tank Coolant Control Valve
		B5501— DEF Dosing Unit	

AT89373,000001A -19-27APR16-2/2

4.5 L Wiring Diagram 8A

DD Aftertreatment Option Continued On Diagram 9A

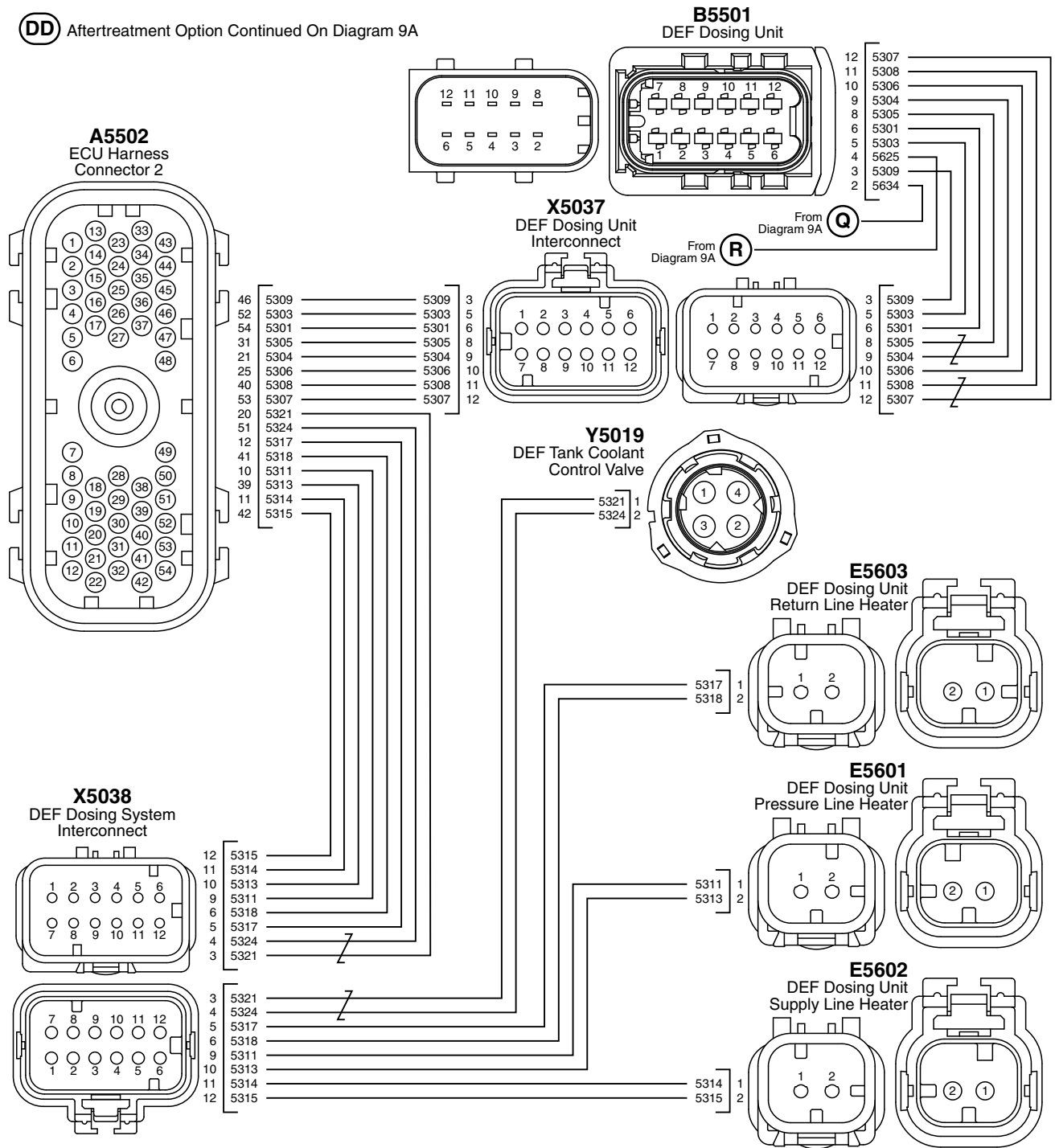

RG28218—UN—27APR16

Continued on next page

BK53208,000037A -19-27APR16-1/2

Troubleshooting

<p>A5502— ECU Harness Connector 2</p> <p>A5502-10— [5311 Brown] DEF Dosing Unit Pressure Line Heater Positive</p> <p>A5502-11— [5314 Yellow] DEF Dosing Unit Supply Line Heater Positive</p> <p>A5502-12— [5317 Violet] DEF Dosing Unit Return Line Heater Positive</p> <p>A5502-20— [5321 Brown] DEF Coolant Control Valve Drive Positive</p> <p>A5502-21— [5304 Yellow] DEF Dosing Unit Pump Drive Positive</p> <p>A5502-25— [5306 Blue] DEF Dosing Unit Pump Position Signal</p>	<p>A5502-31— [5305 Green] DEF Dosing Unit Pump Drive Negative</p> <p>A5502-39— [5313 Orange] DEF Dosing Unit Pressure Line Heater Negative</p> <p>A5502-40— [5308 Gray] DEF Dosing Unit Reversing Valve Drive Negative</p> <p>A5502-41— [5318 Gray] DEF Dosing Unit Return Line Heater Negative</p> <p>A5502-42— [5315 Green] DEF Dosing Unit Supply Line Heater Negative</p> <p>A5502-46— [5309 White] DEF Dosing Unit Pressure Sensor Signal</p>	<p>A5502-51— [5324 Yellow] DEF Coolant Control Valve Drive Negative</p> <p>A5502-52— [5303 Orange] DEF Dosing Unit Heater Negative</p> <p>A5502-53— [5307 Violet] DEF Dosing Unit Reversing Valve Drive Positive</p> <p>A5502-54— [5301 Brown] DEF Dosing Unit Heater Positive</p> <p>DD— Aftertreatment Option Continued On 4.5 L Wiring Diagram 9A</p> <p>E5601— DEF Dosing Unit Pressure Line Heater</p> <p>E5602— DEF Dosing Unit Supply Line Heater</p>	<p>E5603— DEF Dosing Unit Return Line Heater</p> <p>Q— [5634 Yellow] 5 V Sensor Supply #8 Positive From 4.5 L Wiring Diagram 9A</p> <p>R— [5625 Green] 5 V Sensor Supply #7 Return From 4.5 L Wiring Diagram 9A</p> <p>X5038— DEF Dosing System Interconnect</p> <p>Y5019— DEF Tank Coolant Control Valve</p>
---	--	--	---

BK53208.000037A -19-27APR16-2/2

Troubleshooting

A5502— ECU Harness Connector 2	A5502-35— [5604 Yellow] Aftertreatment CAN High	B5204— Aftertreatment Temperature Module	G— [5030 Black] Wiring Shield From 4.5 L Wiring Diagram 5 or 4.5 L Wiring Diagram 6
A5502-01— [5333 Orange] DEF Dosing Injector Drive Negative	A5502-38— [5786 Blue] Aftertreatment Temperature Sensor Signal	B5502— Aftertreatment Inlet NOx Sensor	R5605— Aftertreatment CAN Terminator (120 Ohm)
A5502-06— [5634 Yellow] 5 V Sensor Supply #8a Positive	A5502-44— [5605 Green] Aftertreatment CAN Low	B5503— Aftertreatment Outlet NOx Sensor	X5039— Aftertreatment Interconnect
A5502-13— [5331 Brown] DEF Dosing Injector Drive Positive	A5502-47— [5785 Green] DPF Differential Pressure Sensor Signal	CC— Aftertreatment Option Continued On 4.5 L Wiring Diagram 8	Y5020— DEF Dosing Injector
A5502-16— [5636 Blue] 5 V Sensor Supply #8 Return	A5502-50— [5602 Red] 12 V Sensor Supply #10	E— [5625 Green] 5 V Sensor Supply #7 Return From 4.5 L Wiring Diagram 4	
A5502-28— [5783 Orange] 12 V Sensor Supply	B5109— DPF Differential Pressure Sensor (Engines Equipped With A DPF Only)	F— [5783 Orange] 12 V Sensor Supply From 4.5 L Wiring Diagram 5 or 4.5 L Wiring Diagram 7	

AT89373.000001B -19-27APR16-2/2

4.5 L Wiring Diagram 9A

A5502
ECU Harness
Connector 2

(DD) Aftertreatment Option Continued On Diagram 8A

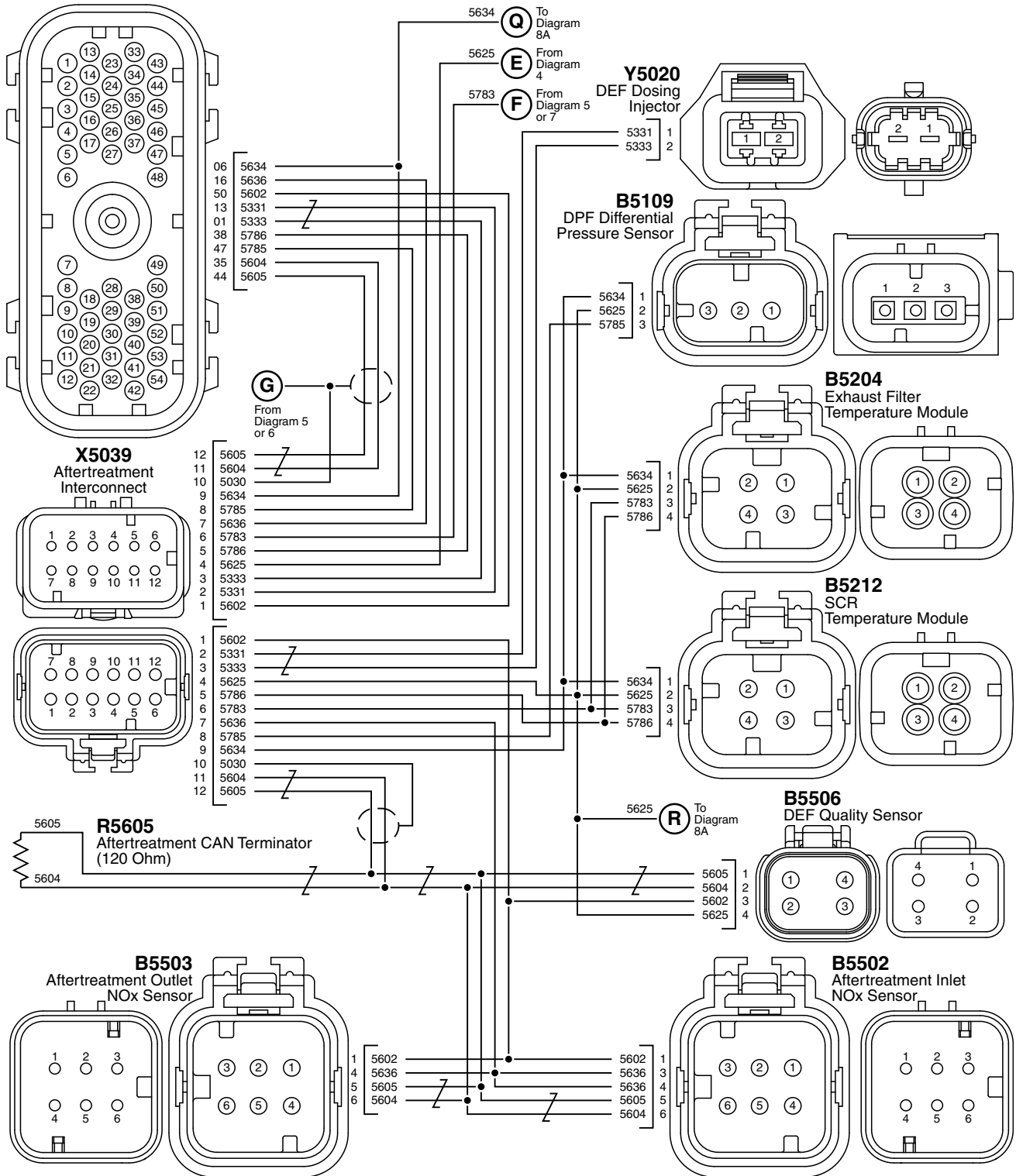

RG28219-UN-27APR16

Continued on next page

BK53208,000037B -19-27APR16-1/2

Troubleshooting

<p>A5502— ECU Harness Connector 2</p> <p>A5502-1— [5333 Orange] DEF Dosing Injector Drive Negative</p> <p>A5502-6— [5634 Yellow] 5 V Sensor Supply #8 Positive</p> <p>A5502-13— [5331 Brown] DEF Dosing Injector Drive Positive</p> <p>A5502-16— [5636 Blue] 5 V Sensor Supply #8 Return</p> <p>A5502-35— [5604 Yellow] Aftertreatment CAN High</p> <p>A5502-38— [5786 Blue] Aftertreatment Temperature Sensor Signal</p>	<p>A5502-44— [5605 Green] Aftertreatment CAN Low</p> <p>A5502-47— [5785 Green] DPF Differential Pressure Sensor Signal</p> <p>A5502-50— [5602 Red] 12 V Sensor Supply #10</p> <p>B5109— DPF Differential Pressure Sensor (If Equipped)</p> <p>B5204— Aftertreatment Temperature Module</p> <p>B5212— SCR Temperature Module (If Equipped)</p> <p>B5502— Aftertreatment Inlet NOx Sensor</p>	<p>B5503— Aftertreatment Outlet NOx Sensor</p> <p>B5506— DEF Quality Sensor</p> <p>DD— Aftertreatment Option Continued On 4.5 L Wiring Diagram 8A</p> <p>E— [5625 Green] 5 V Sensor Supply #7 Return From 4.5 L Wiring Diagram 4</p> <p>F— [5783 Orange] 10 V Sensor Supply From 4.5 L Wiring Diagram 5 or 4.5 L Wiring Diagram 7</p> <p>G— [5030 Black] Wiring Shield From 4.5 L Wiring Diagram 5 or 4.5 L Wiring Diagram 6</p>	<p>Q— To 4.5 L Wiring Diagram 8A</p> <p>R— To 4.5 L Wiring Diagram 8A</p> <p>R5605— Aftertreatment CAN Terminator (120 Ohm)</p> <p>X5039— Aftertreatment Interconnect</p> <p>Y5020— DEF Dosing Injector</p>
---	---	--	---

BK53208,000037B -19-27APR16-2/2

4.5 L Wiring Diagram 10

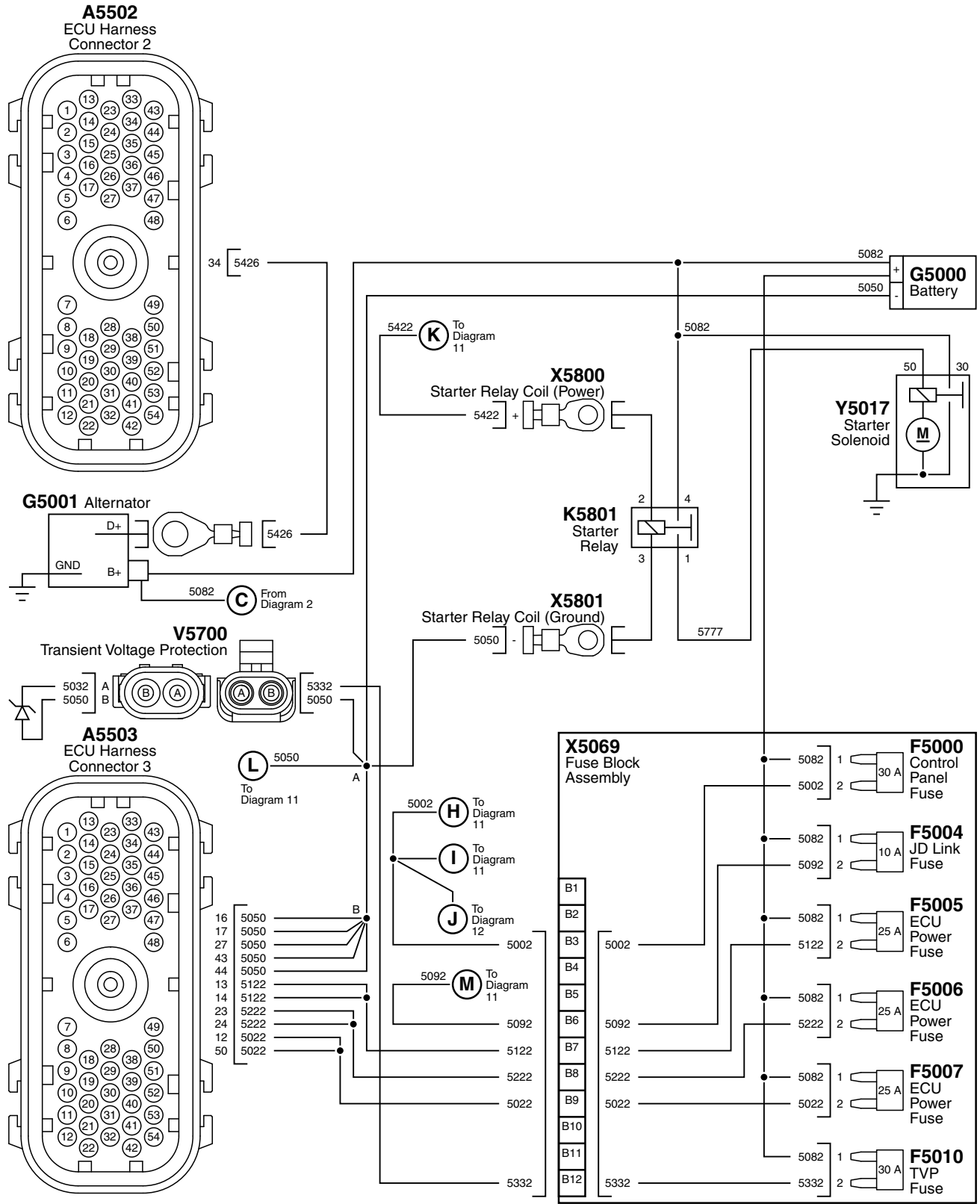

Continued on next page

AT89373.000001C -19-18AUG14-1/2

Troubleshooting

A5502— ECU Harness Connector 2	A5503-27— [5050 Black] Battery Negative	F5010— Transient Voltage Protection Fuse (30 A)	L— To 4.5 L Wiring Diagram 11
A5502-34— [5426 Blue] Alternator Excitation	A5503-43— [5050 Black] Battery Negative	G5000— Battery	M— [5092 Red] JD Link Unswitched Power To 4.5 L Wiring Diagram 11
A5503— ECU Harness Connector 3	A5503-44— [5050 Black] Battery Negative	G5001— Alternator	V5700— Transient Voltage Protection
A5503-12— [5022 Red] ECU Power Positive	A5503-50— [5022 Red] ECU Power Positive	H— [5002 Red] Control Panel Unswitched Power To 4.5 L Wiring Diagram 11	X5069— Fuse Block Assembly
A5503-13— [5122 Red] ECU Power Positive	C— [5082 Red] Battery Power Positive From 4.5 L Wiring Diagram 2	I— [5002 Red] Control Panel Unswitched Power To 4.5 L Wiring Diagram 11	X5069-B12— [5332 Red] Battery Power Positive
A5503-14— [5122 Red] ECU Power Positive	F5000— Control Panel Fuse (30 A)	J— [5002 Red] Control Panel Unswitched Power To 4.5 L Wiring Diagram 12	X5800— Starter Relay Coil (Power)
A5503-16— [5050 Black] Battery Negative	F5004— JD Link Fuse (10 A)	K— [5422 Red] Start To 4.5 L Wiring Diagram 11	X5801— Starter Relay Coil (Ground)
A5503-17— [5050 Black] Battery Negative	F5005— ECU Power Fuse (25 A)	K5801— Starter Relay	Y5017— Starter Solenoid
A5503-23— [5222 Red] ECU Power Positive	F5006— ECU Power Fuse (25 A)	K5801-1— [5777 Violet] Starter Excitation	
A5503-24— [5222 Red] ECU Power Positive	F5007— ECU Power Fuse (25 A)		

AT89373,000001C -19-18AUG14-2/2

4.5 L Wiring Diagram 11

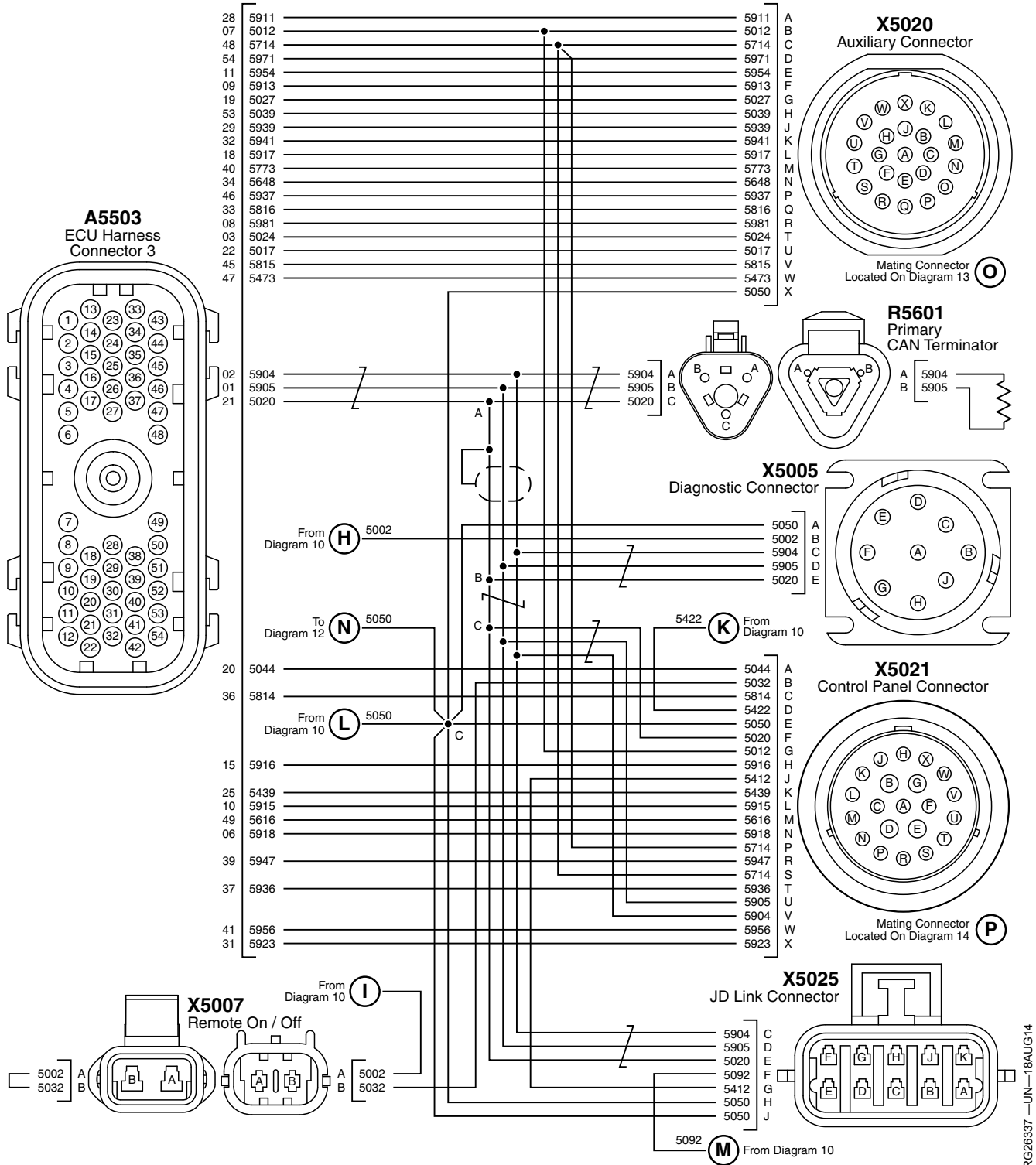

Continued on next page

AT89373,000001D -19-18AUG14-1/2

Troubleshooting

A5503— ECU Harness Connector 3	A5503-21— [5020 Black] Primary CAN Shield	A5503-41— [5956 Blue] Set Accelerator/Bump Up Switch	I— [5002 Red] Control Panel Unswitched Power From 4.5 L Wiring Diagram 10
A5503-01— [5905 Green] Primary CAN Low	A5503-22— [5017 Violet] AC High Pressure Switch	A5503-45— [5815 Green] AC Compressor	N— To 4.5 L Wiring Diagram 12
A5503-02— [5904 Yellow] Primary CAN High	A5503-25— [5439 White] Tachometer	A5503-46— [5937 Violet] Isochronous Governor	O— Mating Connector Located On 4.5 L Wiring Diagram 13
A5503-03— [5024 Yellow] Remote Throttle	A5503-28— [5911 Brown] 5 V Sensor Supply #5 Positive	A5503-47— [5473 Orange] Stop Lamp	P— Mating Connector Located On 4.5 L Wiring Diagram 14
A5503-06— [5918 Gray] Shutdown Override Switch	A5503-29— [5939 White] External Derate Switch	A5503-48— [5714 Yellow] 5 V Sensor Supply #5 Return	R5601— Primary CAN Terminator
A5503-07— [5012 Red] Key Switch	A5503-31— [5923 Orange] Bump Enable Switch	A5503-49— [5616 Blue] 5 V Sensor Supply #4 Positive	X5005— Diagnostic Connector
A5503-08— [5981 Brown] PWM Throttle/Alternator Feedback	A5503-32— [5941 Brown] External Shutdown Switch	A5503-53— [5039 White] Vehicle Speed Input	X5007— Remote On/Off
A5503-09— [5913 Orange] Secondary Throttle	A5503-33— [5816 Blue] Cruise Brake Switch	A5503-54— [5971 Brown] Cruise Cancel/Resume Switch	X5020— Auxiliary Connector
A5503-10— [5915 Green] Primary Throttle	A5503-34— [5648 Gray] Sensor Return #5	K— [5422 Red] Start From 4.5 L Wiring Diagram 10	X5021— Control Panel Connector
A5503-11— [5954 Yellow] Cruise On Switch	A5503-36— [5814 Yellow] 5 V Sensor Supply #4 Return	L— [5050 Black] Battery Negative From 4.5 L Wiring Diagram 10	X5021-B— [5032 Red] Fused Unswitched Power
A5503-15— [5916 Blue] Warning Lamp	A5503-37— [5936 Blue] Cruise Resume/Bump Down Switch	M— [5092 Red] JD Link Unswitched Power From 4.5 L Wiring Diagram 10	X5021-J— [5412 Red] Accessory
A5503-18— [5917 Violet] Cruise Remote	A5503-39— [5947 Violet] Digital Throttle	H— [5002 Red] Control Panel Unswitched Power From 4.5 L Wiring Diagram 10	X5025— JD Link Connector
A5503-19— [5027 Violet] Air Filter Switch	A5503-40— [5773 Orange] Spare Driver Positive		
A5503-20— [5044 Yellow] Wait to Start Lamp			

AT89373,000001D -19-18AUG14-2/2

4.5 L Wiring Diagram 12

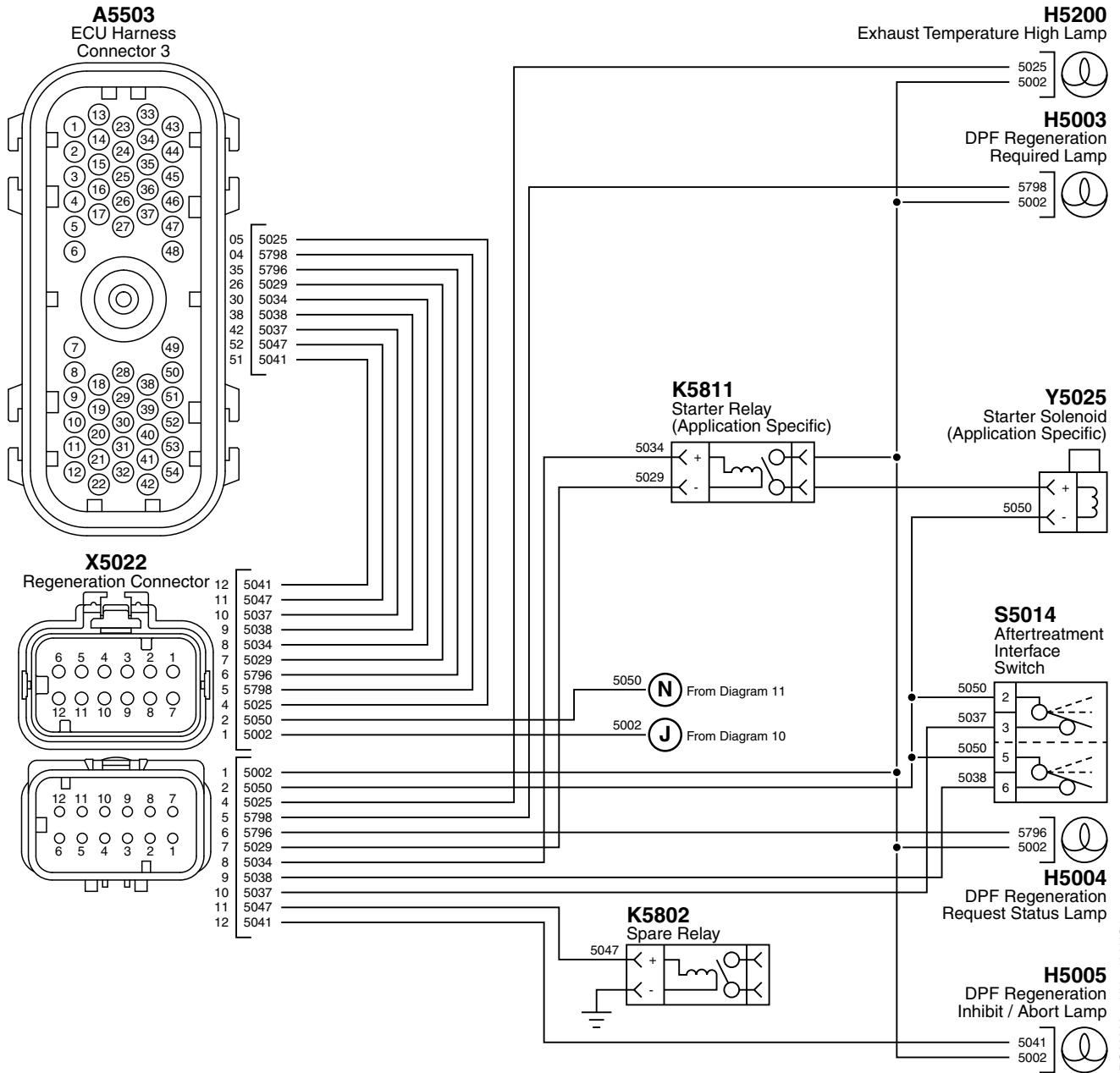

RG26338 —UN—18AUG14

- | | | | |
|--|---|---|---|
| A5503 — ECU Harness Connector | A5503-38 — [5038 Gray] DPF Regeneration Request Switch | H5004 — DPF Regeneration Request Status Lamp | N — [5050 Black] Battery Negative From 4.5 L Wiring Diagram 11 |
| A5503-04 — [5798 Gray] DPF Regeneration Required Lamp | A5503-42 — [5037 Violet] DPF Regeneration Inhibit/Abort Switch | H5005 — DPF Regeneration Inhibit/Abort Lamp | S5014 — Aftertreatment Interface Switch |
| A5503-05 — [5025 Green] Exhaust Temperature High Lamp | A5503-51 — [5041 Brown] DPF Regeneration Inhibit/Abort Lamp | H5200 — Exhaust Temperature High Lamp | X5022 — Regeneration Connector |
| A5503-26 — [5029 White] Starter Relay Control Negative | A5503-52 — [5047 Violet] Spare Driver Positive | J — [5002 Red] Control Panel Unswitched Power From 4.5 L Wiring Diagram 10 | Y5025 — Starter Solenoid (Application Specific) |
| A5503-30 — [5034 Yellow] Starter Relay Control Positive | H5003 — DPF Regeneration Required Lamp | K5811 — Starter Relay (Application Specific) | |
| A5503-35 — [5796 Blue] DPF Regeneration Status Lamp | | K5802 — Spare Relay | |

4.5 L Wiring Diagram 13

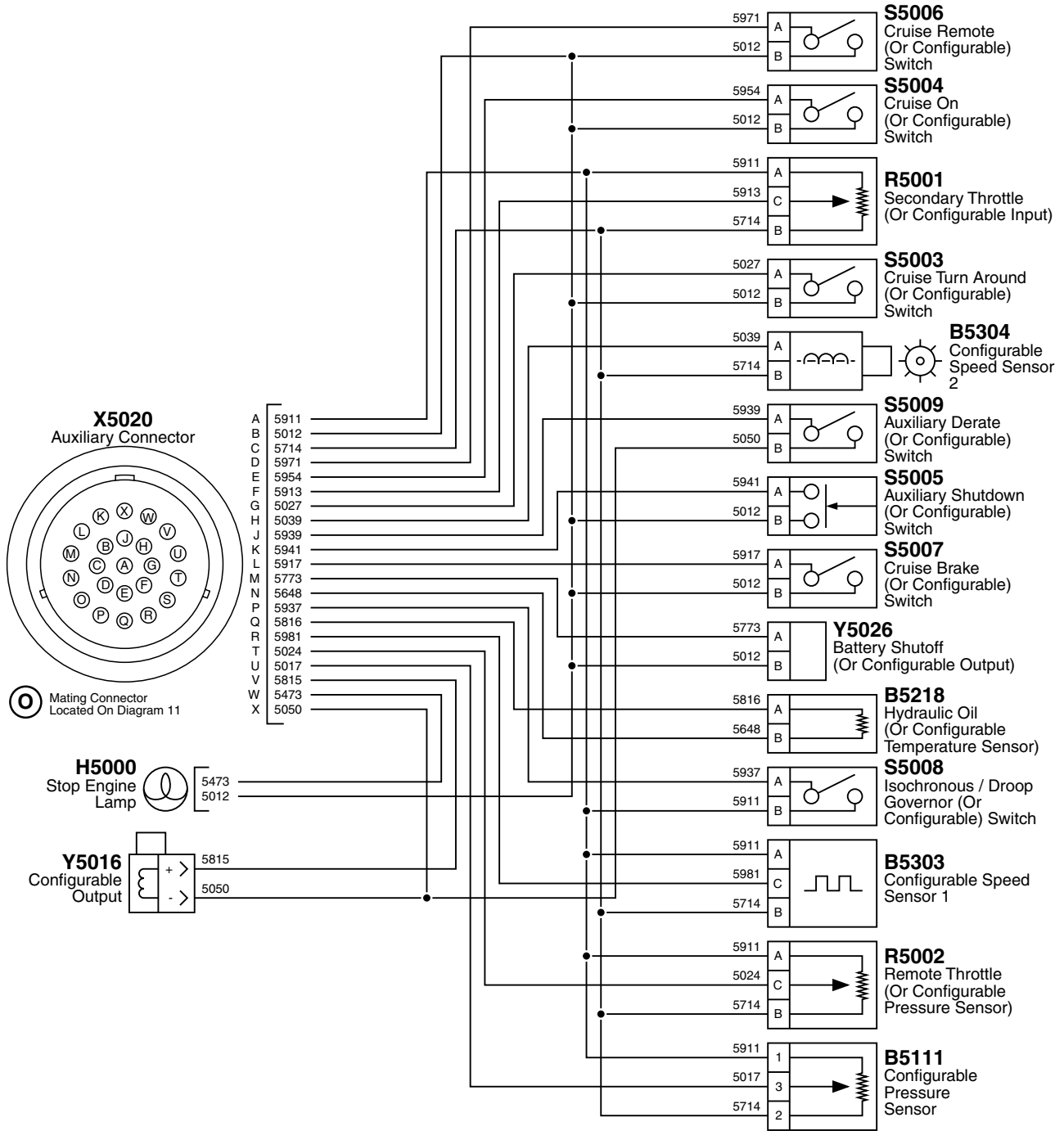

RG26339A — JUN — 06/JUN16

Continued on next page

AT89373,000001F -19-06/JUN16-1/2

Troubleshooting

B5111— Configurable Pressure Sensor	S5006— Cruise Remote (Or Configurable) Switch	X5020-G— [5027 Violet] Cruise Turnaround (Or Configurable) Switch	X5020-R— [5981 Brown] Configurable Speed Sensor 1
B5218— Hydraulic Oil (Or Configurable) Temperature Sensor	S5007— Cruise Brake (Or Configurable) Switch	X5020-H— [5039 White] Configurable Speed Sensor 2	X5020-T— [5024 Yellow] Remote Throttle (Or Configurable) Pressure Sensor
B5303— Configurable Speed Sensor 1	S5008— Isochronous/Droop Governor (Or Configurable) Switch	X5020-J— [5939 White] Auxiliary Derate (Or Configurable) Switch	X5020-U— [5017 Violet] Configurable Pressure Sensor
B5304— Configurable Speed Sensor 2	S5009— Auxiliary Derate (Or Configurable) Switch	X5020-K— [5941 Brown] Auxiliary Shutdown (Or Configurable) Switch	X5020-V— [5815 Green] Configurable Output
H5000— Stop Engine Lamp	X5020— Auxiliary Connector	X5020-L— [5917 Violet] Cruise Brake (Or Configurable) Switch	X5020-W— [5473 Orange] Stop Lamp
O— Mating Connector Located On 4.5 L Wiring Diagram 11	X5020-A— [5911 Brown] 5 V Sensor Supply #5 Positive	X5020-M— [5773 Orange] Battery Shutoff (Or Configurable) Output	X5020-X— [5050 Black] Battery Negative
R5001— Secondary Throttle (Or Configurable Output)	X5020-B— [5012 Red] Key Switch	X5020-N— [5648 Gray] Sensor Return #5	Y5016— Configurable Output
R5002— Remote Throttle (Or Configurable Pressure Sensor)	X5020-C— [5714 Yellow] 5 V Sensor Supply #5 Return	X5020-P— [5937 Violet] Isochronous/Droop Governor (Or Configurable) Switch	Y5026— Battery Shutoff (Or Configurable Output)
S5003— Cruise Turnaround (Or Configurable) Switch	X5020-D— [5971 Brown] Cruise Remote (Or Configurable) Switch	X5020-Q— [5816 Blue] Hydraulic Oil (Or Configurable) Temperature Sensor	
S5004— Cruise On (Or Configurable) Switch	X5020-E— [5954 Yellow] Cruise On (Or Configurable) Switch		
S5005— Auxiliary Shutdown (Or Configurable) Switch	X5020-F— [5913 Orange] Secondary Throttle (Or Configurable Input)		

AT89373,000001F -19-06JUN16-2/2

4.5 L Wiring Diagram 14

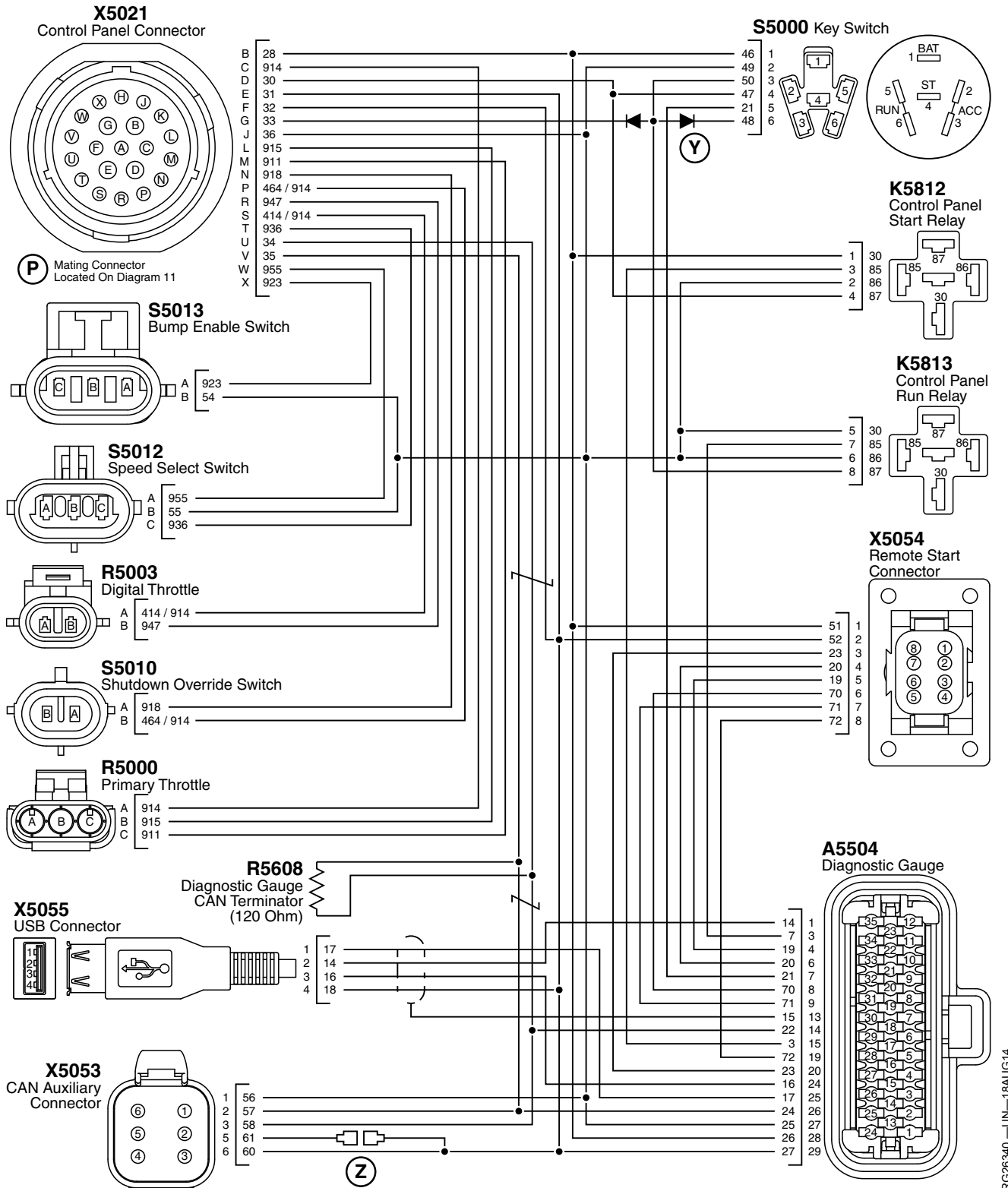

Continued on next page

AT89373.0000020 -19-18AUG14-1/2

RG26340—UN—18AUG14

Troubleshooting

A5504— Diagnostic Gauge	A5504-25— [17 White] USB VBus	X5021-D— [30 White] Start	X5021-T— [936 White] Cruise Resume/Bump Down Switch
A5504-1— [14 White] USB D Negative	K5812— Control Panel Start Relay	X5021-E— [31 White] Battery Negative	X5021-U— [34 White] Primary CAN Low
A5504-3— [7 White] Run Return	K5813— Control Panel Run Relay	X5021-F— [32 White] Primary CAN Shield	X5021-V— [35 White] Primary CAN High
A5504-4— [19 White] Pre-Start Alarm	P— Mating Connector Located On 4.5 L Wiring Diagram 11	X5021-G— [33 White] Key Switch	X5021-W— [955 White] Set Accelerator/Bump Up Switch
A5504-6— [20 White] Remote Stop	R5000— Primary Throttle	X5021-J— [36 White] Accessory	X5021-X— [923 White] Bump Enable Switch
A5504-7— [21 White] Manual Input Signal	R5003— Digital Throttle	X5021-L— [915 White] Primary Throttle	X5053— CAN Auxiliary Connector
A5504-8— [70 White] Fuel Level Signal	R5608— Diagnostic Gauge CAN Terminator (120 Ohm)	X5021-M— [911 White] 5 V Sensor Supply #4 Positive	X5054— Remote Start Connector
A5504-9— [71 White] Interlock Signal	S5000— Key Switch	X5021-N— [918 White] Shutdown Override Switch	X5055— USB Connector
A5504-13— [15 White] USB Shield	S5010— Shutdown Override Switch	X5021-P— [464/914 White] 5 V Sensor Supply #5 Return	Y— Starter Switch Diodes
A5504-15— [3 White] Start	S5012— Speed Select Switch	X5021-R— [947 White] Digital Throttle	Z— Gauge Backlight Quick Disconnect
A5504-19— [72 White] Auxiliary Input	S5013— Bump Enable Switch	X5021-S— [414/914 White] 5 V Sensor Supply #5 Return	
A5504-20— [23 White] Remote Start	X5021— Control Panel Connector		
A5504-24— [16 White] USB D Positive	X5021-B— [28 White] Fused Unswitched Power		
	X5021-C— [914 White] 5 V Sensor Supply #4 Return		

AT89373.0000020 -19-18AUG14-2/2

Storage

Engine Storage Guidelines

IMPORTANT: Avoid possible poor engine performance and damage. Special considerations should be taken prior to storage when using biodiesel. See biodiesel Fuel in the Fuels, Lubricants, and Coolant Section.

1. John Deere engines can be stored outside for up to three months with no long-term preparation if covered by a waterproof covering. No outside storage is recommended without a waterproof covering.
2. John Deere engines can be stored in a standard overseas shipping container for up to three months with no long-term preparation.
3. John Deere engines can be stored inside for up to six months with no long-term preparation.
4. John Deere engines expected to be stored for more than six months **must** have long-term storage preparation. See Preparing Engine for Long-Term Storage in the Storage Section.

RK80614,0000060 -19-31AUG21-1/1

Preparing Engine for Long-Term Storage

IMPORTANT: Anytime the engine is not used for over six months, the following recommendations for storing it and removing it from storage helps to minimize corrosion and deterioration.

IMPORTANT: Long-term storage is not advised when using biodiesel. For storage longer than one year, use straight hydrocarbon fuel.

If biodiesel must be used it is recommended the blend not exceed B7 and a high-quality fuel stabilizer be used. Storage should not exceed one year.

For more information see **BioDiesel Fuel** in the Fuels, Lubricants, and Coolants Section.

NOTE: The following storage preparations are used for long-term engine storage up to one year. After that, the engine should be started, warmed up, and retreated for an extended storage period.

1. Change engine oil and replace filter. Used oil does not give adequate protection. Add 30 mL of rust preventive oil to the engine crankcase for every 1 L of engine oil, or 1 oz of rust preventative oil per 1 qt. of engine oil. This rust preventive oil should be an SAE 10W oil with 1%-4% morpholine or equivalent vapor corrosion inhibitor, such as NOX RUST VCI-10 OIL from Daubert Chemical Company, Inc.
2. Replace air cleaner.

IMPORTANT: Avoid damage to the engine cooling system components. Engine cooling system must be drained, flushed, and refilled for prolong storage of more than one year.

3. Draining and flushing of cooling system is not necessary if the engine is only stored for less than one year. However, for extended storage periods of a year or longer, it is recommended that the cooling system be drained, flushed, and refilled. Refill with appropriate coolant. See **Diesel Engine Coolant (engine with wet sleeve cylinder liners)** in the Fuels, Lubricants, and Coolants Section.
4. Prepare a solution of diesel fuel and rust preventive oil in a temporary container, add 78 mL of rust preventive oil per 1 L of diesel fuel, 10 oz of rust preventive oil per 1 gal of diesel fuel.
5. Remove existing lines and plugs as required. Run a temporary line from the temporary container to the engine fuel intake before the fuel filters, and another temporary line from the fuel return to the temporary container, so rust preventive oil solution is circulated through the injection system during cranking.

IMPORTANT: Do not operate starter more than 30 seconds at a time. Wait at least 2 minutes for starter to cool before trying again.



RG35531 —JUN—22MAR22

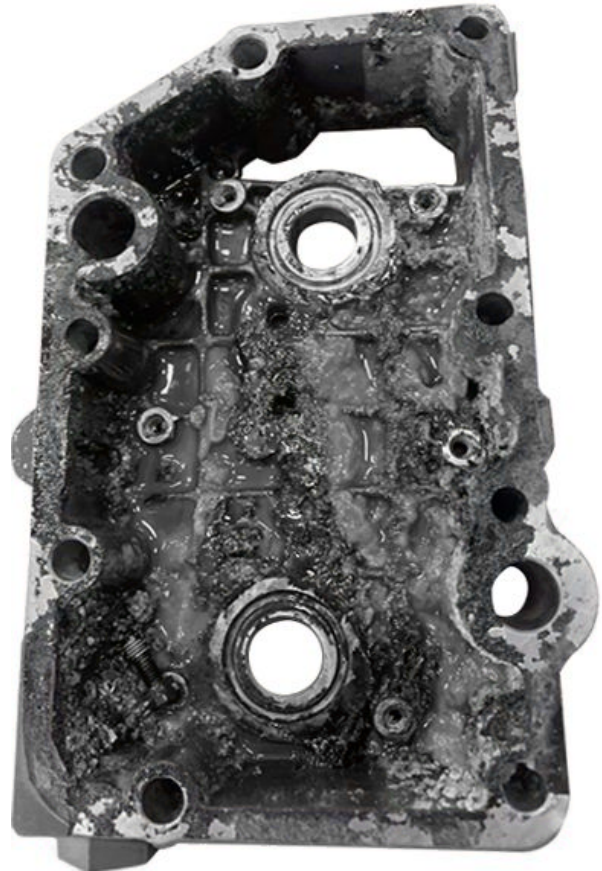

RG35532 —JUN—22MAR22

Effects of Prolong Storage of Coolant — More Than One Year

6. Crank the engine several revolutions with starter. Do not allow the engine to start. This allows rust preventive oil solution to circulate.

See your authorized dealer for the proper procedure for your application.

7. Remove temporary lines installed in Step 5 and replace any lines or plugs previously removed.
8. Loosen (or remove) and store fan and alternator poly-vee belt.

Continued on next page

RK80614,0000061 -19-22MAR22-1/2

Storage

9. Remove and clean batteries. Store them in a cool, dry place and keep them fully charged.
10. Disengage the clutch for any driveline.
11. For extended storage periods of a year or longer, drain or siphon DEF fluid from DEF tank.
12. Clean the exterior of the engine with salt-free water and touch up any scratched or chipped painted surfaces with a good quality paint.
13. Coat all exposed bare metal surfaces with grease or corrosion inhibitor if not feasible to paint.
14. Seal all openings on engine with plastic bags and tape.
15. Store the engine in a dry protected place. If engine must be stored outside, cover it with a waterproof canvas or other suitable protective material and use a strong waterproof tape.

RK80614,0000061 -19-22MAR22-2/2

Removing Engine from Long-Term Storage

NOTE: The following storage removal procedure is used for long-term engine storage up to one year. After that, the engine should be started, warmed up, and retreated for an extended storage period.

Refer to the appropriate section for detailed services listed below or have an authorized servicing dealer or engine distributor perform unfamiliar services.

1. Remove all protective coverings from engine. Unseal all openings in engine and remove covering from electrical systems.
2. Remove grease from all exposed metal surfaces.
3. Remove the batteries from storage. Install batteries (fully charged) and connect the terminals.
4. Install fan and alternator poly-vee belt, if removed.
5. Fill fuel tank.
6. If drained, fill DEF tank with new DEF.

If not drained, DEF must pass visual, smell, and concentration checks before the engine can be ran. See [Diesel Exhaust Fluid \(DEF\) — Use in Selective Catalytic Reduction \(SCR\) Equipped Engines](#) in the Fuels, Lubricants, and Coolants Section for more information.

7. Perform all appropriate prestarting checks. See [Daily Prestarting Checks](#) in the Lubrication & Maintenance — Daily Section for more information.

IMPORTANT: DO NOT operate starter more than 30 seconds at a time. Wait at least 2 minutes for starter to cool before trying again.

8. Crank engine for 20 seconds with starter. Do not allow the engine to start. Wait 2 minutes and crank engine an additional 20 seconds to assure bearing surfaces are adequately lubricated.
See the authorized dealer for the proper procedure for your application.
9. Start engine and run at low idle and no load for 15 minutes.
10. Shut engine off. Change engine oil and replace filter.
11. Warm up engine and check all gauges before placing engine under load.
12. On the first day of operation after storage, check overall engine for leaks and check all gauges for correct operation.

NOTE: If using BioDiesel blends after long-term storage, frequency of fuel filter plugging can increase initially.

RK80614,0000062 -19-07JUL20-1/1

Specifications

General OEM Engine Specifications

ITEM	UNIT OF MEASURE	4045HFC09 4045HFG09	4045HFC04 4045HFG04
General Data			
Number of Cylinders		4	4
Bore	mm (in.)	106 (4.2)	106 (4.2)
Stroke	mm (in.)	127 (5.0)	127 (5.0)
Displacement	L (cu in.)	4.5 (275)	4.5 (275)
Compression Ratio		17.2:1	17.0:1
Aspiration		Air-To-Air Aftercooled, Turbocharged	Air-To-Air Aftercooled, Turbocharged
Engine Firing Order		1-3-4-2	1-3-4-2
Valves Per Cylinder		2 Intake 2 Exhaust	2 Intake 2 Exhaust
Valve Clearance (Cold)	mm (in.)	Intake — 0.46 (0.018) Exhaust — 0.53 (0.021)	Intake — 0.46 (0.018) Exhaust — 0.53 (0.021)
Physical Dimensions			
Length	mm (in.)	870 (34.4)	870 (34.4)
Width	mm (in.)	635 (25)	650 (25.6)
Height	mm (in.)	1130 (44.5)	1050 (41.3)
Weight	kg (lb.)	570 (1257)	550 (1213)
Performance Data			
Power and Speed Ratings		See <u>Engine Power And Speed Rating Specifications</u> in the Specifications Section.	See <u>Engine Power And Speed Rating Specifications</u> in the Specifications Section.
Lubrication System			
Crankcase Oil Fill Capacity		See <u>Engine Crankcase Oil Fill Quantities</u> in the Specifications Section.	See <u>Engine Crankcase Oil Fill Quantities</u> in the Specifications Section.
Oil Pressure At Rated Speed (2400 rpm), Full Load With Oil Warmed to 97 °C (207 °F) 15W40 Oil	kPa (Bar) (psi)	385 (3.85) (56)	370 (3.70) (54)
Oil Pressure At Low Idle (Minimum)	kPa (Bar) (psi)	150 (1.50) (22)	150 (1.50) (22)
Cooling System			
Thermostat Start To Open Temperature	°C (°F)	85 (185)	85 (185)
Thermostat Fully Open Temperature	°C (°F)	97 (207)	97 (207)
Recommended Radiator Pressure Cap	kPa (Bar) (psi)	103—124 (1.03—1.24) (15—18)	103—124 (1.03—1.24) (15—18)
Fuel System			
ECU Level		L34	L34
Fuel Injection Type		HPCR	HPCR
Primary Fuel Filter		10 micron	10 micron
Secondary Fuel Filter		2 micron	2 micron
Electrical System			
Battery Capacities 12-Volt System	CCA	640	640
Reserve Capacity 12-Volt System	Minutes	285	285

Continued on next page

ZE59858,0000028 -19-19AUG14-1/2

Specifications

ITEM	UNIT OF MEASURE	4045HFC09 4045HFG09	4045HFC04 4045HFG04
Battery Capacities 24-Volt System	CCA	570	570
Reserve Capacities 24-Volt System	Minutes	275	275
Air System			
Maximum Air Intake Restriction	kPa (Bar) (psi)	12 (3.0) (0.44)	12 (3.0) (0.44)
Maximum Exhaust Back Pressure	kPa (Bar) (psi)	30 (7.5) (1.09)	30 (7.5) (1.09)

ZE59858,0000028 -19-19AUG14-2/2

Specifications

Engine Power and Speed Rating Specifications

vary depending upon specific vehicle application requirements. Refer to your machine operator's manual for engine speeds that are different from those preset at the factory.

NOTE: Engine speeds listed are preset to factory specification for application. Therefore, speeds may

ELECTRONIC SOFTWARE OPTION CODES 12V	ELECTRONIC SOFTWARE OPTION CODES 24V	POWER RATING AT RATED SPEED WITHOUT FAN kW (hp)	RATED SPEED ^a (rpm)	SLOW IDLE (rpm)	FAST IDLE ^b (rpm)
Industrial Units — 4045HFC04					
7AUD	7AUE	104 (140)	2200	800	2400
7AUF ^c	7AUH ^c	100 (134)	2400	800	2600
7AUJ	7AUK	93 (125)	2400	800	2600
7AUL	7AUM	93 (125)	2200	800	2400
7AUN	7AUP	86 (115)	2400	800	2600
7AUQ	7AUR	86 (115)	2200	800	2400
7AUS ^c	7AUT ^c	74 (100)	2400	800	2600
7AAU	7AUV	74 (100)	2400	800	2600
7AUW ^c	7AUX ^c	74 (100)	2200	800	2400
7AUY	7AUZ	74 (100)	2200	800	2400
7AVA ^c	7AVB ^c	63 (84)	2400	800	2600
7AVC	7AVD	63 (84)	2400	800	2600
7AVE ^c	7AVF ^c	63 (84)	2200	800	2400
7AVG	7AVH	63 (84)	2200	800	2400
Industrial Units — 4045HFC09					
7ASP	7AST	129 (173)	2400	800	2600
7ASU	7ASV	129 (173)	2200	800	2400
7ASW ^c	7ASX ^c	116 (155)	2400	800	2600
7ASY	7ASZ	116 (155)	2400	800	2600
7ATA ^c	7ATB ^c	116 (155)	2200	800	2400
7ATC	7ATD	116 (155)	2200	800	2400
7ATE ^c	7ATF ^c	104 (140)	2400	800	2600
7ATG	7ATH	104 (140)	2400	800	2600
7ATJ ^c	7ATK ^c	104 (140)	2200	800	2400
7ATL	7ATM	104 (140)	2200	800	2400
7ATN ^c	7ATP ^c	93 (125)	2400	800	2600
7ATQ	7ATR	93 (125)	2400	800	2600
7ATS ^c	7ATT ^c	93 (125)	2200	800	2400
7ATU	7ATV	93 (125)	2200	800	2400
Industrial Units — 4045HN056					
7BFG	—	129 (173)	2200	900	2400
Industrial Units — 4045HB551					
7BDF ^c	—	76 (102)	2400	800	2600
Generator Sets — 4045HFG09					
7ATW	7ATX	124 (166)	1800	1800	—

Continued on next page

ZE59858,0000029 -19-13AUG20-1/2

Specifications

ELECTRONIC SOFTWARE OPTION CODES 12V	ELECTRONIC SOFTWARE OPTION CODES 24V	POWER RATING AT RATED SPEED WITHOUT FAN kW (hp)	RATED SPEED ^a (rpm)	SLOW IDLE (rpm)	FAST IDLE ^b (rpm)
7ATY	7ATZ	105 (140)	1800	1800	—
Generator Sets — 4045HFG04					
7AVJ	7AVK	99 (133); 80 (107)	1800; 1500	1800; 1200	—
7AVL	7AVM	80 (107); 80 (107)	1800; 1500	1800; 1200	—
7AVN	7AVP	67 (90); 67 (90)	1800; 1500	1800; 1200	—

^aGenerator set engines usually run at 1500 rpm (50 Hz) or 1800 (60 Hz) when operating under load depending on cycles of AC current.

^bParasitic loads and ECU settings can change the fast idle speed. See your authorized John Deere engine distributor or servicing dealer for more information.

^cThese Industrial engines have a power bulge which allows for INTERMITTENT operation above rated power.

ZE59858,0000029 -19-13AUG20-2/2

Engine Crankcase Oil Fill Quantities

To determine the option code for the oil fill quantity of your engine, refer to the engine option code label affixed to the rocker arm cover. The first two digits of the code (19) identify the oil pan option group. The last two digits of each code identify the specific oil pan on your engine.

The following table lists engine crankcase oil fill quantities, including oil filter:

Oil Pan Option Code(s)	Crankcase Oil Capacity L (qt)
1903	13 (13.7)
1923	15 (15.9)
1976	20.5 (21.7)
19AE	14.7 (15.5)
19AZ	20.5 (21.7)
19BA	15 (15.9)
19BB	13 (13.7)
19BC	14.7 (15.5)
19GK	20.5 (21.7)

NOTE: Crankcase oil capacity may vary slightly from amount shown. ALWAYS fill crankcase to within crosshatch on dipstick. DO NOT overfill.

ZE59858,000002A -19-11MAR14-1/1

Specifications

Unified Inch Bolt and Screw Torque Values

TS1671 —UN—01MAY03

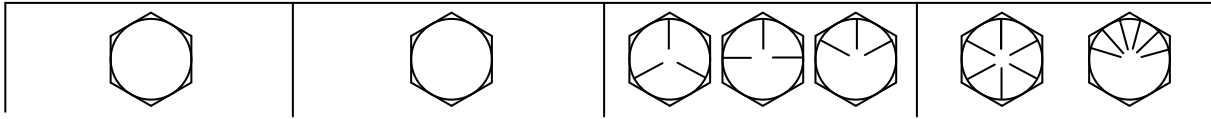

Bolt or Screw Size	SAE Grade 1 ^a				SAE Grade 2 ^b				SAE Grade 5, 5.1 or 5.2				SAE Grade 8 or 8.2			
	Hex Head ^c		Flange Head ^d		Hex Head ^c		Flange Head ^d		Hex Head ^c		Flange Head ^d		Hex Head ^c		Flange Head ^d	
	N·m	lb·in	N·m	lb·in	N·m	lb·in	N·m	lb·in	N·m	lb·in	N·m	lb·in	N·m	lb·in	N·m	lb·in
1/4	3.1	27.3	3.2	28.4	5.1	45.5	5.3	47.3	7.9	70.2	8.3	73.1	11.2	99.2	11.6	103
													N·m	lb·ft	N·m	lb·ft
5/16	6.1	54.1	6.5	57.7	10.2	90.2	10.9	96.2	15.7	139	16.8	149	22.2	16.4	23.7	17.5
									N·m	lb·ft	N·m	lb·ft				
3/8	10.5	93.6	11.5	102	17.6	156	19.2	170	27.3	20.1	29.7	21.9	38.5	28.4	41.9	30.9
					N·m	lb·ft	N·m	lb·ft								
7/16	16.7	148	18.4	163	27.8	20.5	30.6	22.6	43	31.7	47.3	34.9	60.6	44.7	66.8	49.3
	N·m	lb·ft	N·m	lb·ft												
1/2	25.9	19.1	28.2	20.8	43.1	31.8	47	34.7	66.6	49.1	72.8	53.7	94	69.3	103	75.8
9/16	36.7	27.1	40.5	29.9	61.1	45.1	67.5	49.8	94.6	69.8	104	77	134	98.5	148	109
5/8	51	37.6	55.9	41.2	85	62.7	93.1	68.7	131	96.9	144	106	186	137	203	150
3/4	89.5	66	98	72.3	149	110	164	121	230	170	252	186	325	240	357	263
7/8	144	106	157	116	144	106	157	116	370	273	405	299	522	385	572	422
1	216	159	236	174	216	159	236	174	556	410	609	449	785	579	860	634
1-1/8	305	225	335	247	305	225	335	247	685	505	751	554	1110	819	1218	898
1-1/4	427	315	469	346	427	315	469	346	957	706	1051	775	1552	1145	1703	1256
1-3/8	564	416	618	456	564	416	618	456	1264	932	1386	1022	2050	1512	2248	1658
1-1/2	743	548	815	601	743	548	815	601	1665	1228	1826	1347	2699	1991	2962	2185

The nominal torque values listed are for general use only with the assumed wrenching accuracy of 20%, such as a manual torque wrench. DO NOT use these values if a different torque value or tightening procedure is given for a specific application. For lock nuts, for stainless steel fasteners, or for nuts on U-bolts, see the tightening instructions for the specific application.

Replace fasteners with the same or higher property class. If higher property class fasteners are used, tighten these to the strength of the original.

- Make sure that fastener threads are clean.
- Apply a thin coat of Hy-Gard™ or equivalent oil under the head and on the threads of the fastener, as shown in the following image.
- Be conservative with the amount of oil to reduce the potential for hydraulic lockup in blind holes due to excessive oil.
- Properly start thread engagement.

TS1741 —UN—22MAY18

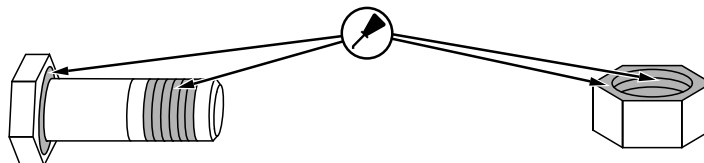

^aGrade 1 applies for hex cap screws over 6 in (152 mm) long, and for all other types of bolts and screws of any length.

^bGrade 2 applies for hex cap screws (not hex bolts) up to 6 in (152 mm) long.

^cHex head column values are valid for ISO 4014 and ISO 4017 hex head, ISO 4162 hex socket head, and ISO 4032 hex nuts.

^dHex flange column values are valid for ASME B18.2.3.9M, ISO 4161, or EN 1665 hex flange products.

DX.TORQ1 -19-09MAY22-1/1

Specifications

Metric Bolt and Screw Torque Values

TS1742 —UN—31MAY18

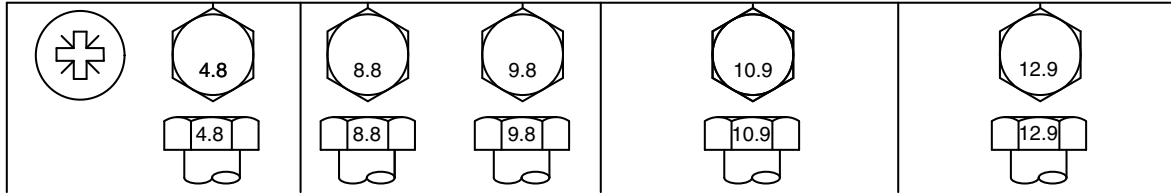

Bolt or Screw Size	Class 4.8				Class 8.8 or 9.8				Class 10.9				Class 12.9			
	Hex Head ^a		Flange Head ^b		Hex Head ^a		Flange Head ^b		Hex Head ^a		Flange Head ^b		Hex Head ^a		Flange Head ^b	
	N·m	lb·in	N·m	lb·in	N·m	lb·in	N·m	lb·in	N·m	lb·in	N·m	lb·in	N·m	lb·in	N·m	lb·in
M6	3.6	31.9	3.9	34.5	6.7	59.3	7.3	64.6	9.8	86.7	10.8	95.6	11.5	102	12.6	112
									N·m	lb·ft	N·m	lb·ft	N·m	lb·ft	N·m	lb·ft
M8	8.6	76.1	9.4	83.2	16.2	143	17.6	156	23.8	17.6	25.9	19.1	27.8	20.5	30.3	22.3
			N·m	lb·ft	N·m	lb·ft	N·m	lb·ft								
M10	16.9	150	18.4	13.6	31.9	23.5	34.7	25.6	46.8	34.5	51	37.6	55	40.6	60	44.3
	N·m	lb·ft														
M12	—	—	—	—	55	40.6	61	45	81	59.7	89	65.6	95	70.1	105	77.4
M14	—	—	—	—	87	64.2	96	70.8	128	94.4	141	104	150	111	165	122
M16	—	—	—	—	135	99.6	149	110	198	146	219	162	232	171	257	190
M18	—	—	—	—	193	142	214	158	275	203	304	224	322	245	356	263
M20	—	—	—	—	272	201	301	222	387	285	428	316	453	334	501	370
M22	—	—	—	—	365	263	405	299	520	384	576	425	608	448	674	497
M24	—	—	—	—	468	345	518	382	666	491	738	544	780	575	864	637
M27	—	—	—	—	683	504	758	559	973	718	1080	797	1139	840	1263	932
M30	—	—	—	—	932	687	1029	759	1327	979	1466	1081	1553	1145	1715	1265
M33	—	—	—	—	1258	928	1398	1031	1788	1319	1986	1465	2092	1543	2324	1714
M36	—	—	—	—	1617	1193	1789	1319	2303	1699	2548	1879	2695	1988	2982	2199

The nominal torque values listed are for general use only with the assumed wrenching accuracy of 20%, such as a manual torque wrench. DO NOT use these values if a different torque value or tightening procedure is given for a specific application. For lock nuts, for stainless steel fasteners, or for nuts on U-bolts, see the tightening instructions for the specific application.

Replace fasteners with the same or higher property class. If higher property class fasteners are used, tighten these to the strength of the original.

- Make sure that fastener threads are clean.
- Apply a thin coat of Hy-Gard™ or equivalent oil under the head and on the threads of the fastener, as shown in the following image.
- Be conservative with the amount of oil to reduce the potential for hydraulic lockup in blind holes due to excessive oil.
- Properly start thread engagement.

TS1741 —UN—22MAY18

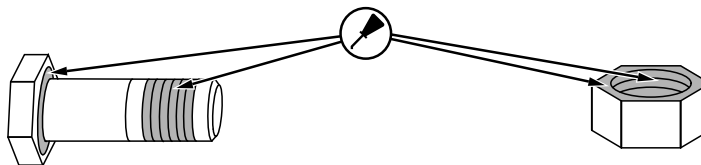

^aHex head column values are valid for ISO 4014 and ISO 4017 hex head, ISO 4162 hex socket head, and ISO 4032 hex nuts.

^bHex flange column values are valid for ASME B18.2.3.9M, ISO 4161, or EN 1665 hex flange products.

DX,TORQ2 -19-09MAY22-1/1

Lubrication and Maintenance Records

Using Lubrication and Maintenance Records

Refer to specific Lubrication and Maintenance Section for detailed service procedures.

1. Keep a record of the number of hours the engine is operated by regular observation of hour meter.
2. Check the record regularly to learn when the engine needs service.
3. DO ALL the services within an interval section. Write the number of hours (from the service records) and

the date in the spaces provided. For a complete listing of all items to be performed and the service intervals required, refer to the quick-reference chart near the front of the Lubrication and Maintenance Section 30.

NOTE: The service recommendations covered in this manual are for the accessories that are provided by John Deere. Follow manufacturer's service recommendations for servicing engine driven equipment not supplied by Deere.

ZE59858,0000290 -19-20AUG21-1/1

Daily (Prestarting) Service

NOTE: See Daily Prestarting Checks in the Lubrication & Maintenance — Daily Section for detailed procedures.

- Check engine oil level.
- Check coolant level.

Drain water from fuel filters.

Check air cleaner dust unloader valve and air filter restriction indicator, if equipped.

Perform visual walk around inspection.

ZE59858,0000291 -19-08JUL13-1/1

500 Hours of Operation or Every 12 Months Service

- Service fire extinguisher.
- Service battery.
- Change engine oil and filter. ¹
- Check coolant pump.
- Check open crankcase vent (OCV) system.
- Remove and replace fuel filter elements.
- Check belt wear.

- Check belt tensioner.
- Check cooling system.
- Pressure test cooling system.
- Check engine speeds.
- Check engine mounts.
- Check engine ground.

Hours									
Date									
Hours									
Date									
Hours									
Date									
Hours									
Date									

¹Service intervals depend on sulfur content of the diesel fuel, oil pan capacity, and the oil and filter used. (See Diesel Engine Oil and Filter Service Intervals in the Fuels, Lubricants, and Coolants Section.)

ZE59858,00000DC -19-14JAN21-1/1

1500 Hours of Operation Service

Change open crankcase ventilation (OCV) filter.

Hours									
Date									
Hours									
Date									
Hours									
Date									
Hours									
Date									

ZE59858,00000DD -19-02AUG13-1/1

1500 Hours of Operation or Every 36 Months Service

Change DEF dosing unit filter.

Check crankshaft vibration damper.

Replace DEF tank header suction screen.

Hours									
Date									
Hours									
Date									
Hours									
Date									
Hours									
Date									

ZE59858,00000DF -19-21MAY21-1/1

3000 Hours of Operation or Every 36 Months Service

Adjust valve clearance.

Check crankshaft vibration damper.

Testing glow plugs for continuity.

Hours									
Date									
Hours									
Date									
Hours									
Date									
Hours									
Date									

ZE59858,00000DE -19-21MAY21-1/1

6000 Hours of Operation or Every 72 Months Service

Flush cooling system.

Test Thermostats.

Hours									
Date									
Hours									
Date									
Hours									
Date									
Hours									
Date									

ZE59858,00000E0 -19-02AUG13-1/1

8000 Hours of Operation or Every 36 Months Service

Replace Inline DEF Filter.

Hours									
Date									
Hours									
Date									
Hours									
Date									
Hours									
Date									

KP41357,0000034 -19-17DEC19-1/1

Service as Required

Drain water from fuel filters when alarm sounds.

Add coolant.

Clean DEF tank.

Pre-Start Cleaning Guide.

Service air cleaner.

Clean exhaust filter.

Replace fan-alternator belt.

Check fuses.

Check electrical wiring and connectors.

Check air compressor (if equipped). (See your qualified engine service provider.)

Check Refrigerant (A/C) compressor (if equipped). (See your qualified engine service provider.)

Replace aftertreatment DEF dosing system coolant filter.

Clean and/or replace DEF tank inlet screen.

Hours									
Date									
Hours									
Date									
Hours									
Date									

ZE59858,00000E1 -19-17DEC19-1/1

Warranty

John Deere Warranty in OEM Applications

Overview

This section focuses on John Deere engines marketed in products manufactured by companies other than John Deere or its affiliates, and on John Deere repower engines in all applications. Herein appears the original warranty applicable to the engine as delivered to the retail purchaser on or after 1 May 2010. The following is information about the warranty and warranty service.

NOTE: "John Deere" means John Deere Power Systems with respect to users in the United States, John Deere Canada ULC with respect to users in Canada, and Deere & Company or its subsidiary responsible for making John Deere equipment in other countries where the user is located.

Promptly register the engine online at <https://warrantyregistration.deere.com/WarrantyReg/web/WarrantyReg>.

When Warranty Service Is Needed

The nearest dealer stands ready with genuine parts and trained and equipped personnel should the need arise. If following the Operator's Manual delivered with the engine/machine are not adequate to correct an engine problem, contact the nearest John Deere service dealer for assistance. Authorized engine service dealers can be found at: <https://www.deere.com/or> <https://www.deere.ca/> (click on "Find a Dealer").

NOTE: When requesting warranty service, the purchaser must be prepared to provide proof that the engine is within the warranty period.

The following information is always required: Engine serial number, date of delivery, engine owner, name and location of dealer and specific person contacted, date of contact, nature of engine problem, and outcome of the service dealer contact.

Given that normally it is the dealer contacted who in the end provides the service required, maintaining a purchaser-dealer relationship of mutual respect from the beginning is always helpful.

Privacy Notice

At John Deere privacy is important. We collect, use, and disclose personal information in accordance with the John Deere privacy statement. For instance, we collect, use, and disclose personal information to provide the products and services requested; to communicate with the customer (examples include warranty and product improvement programs) and to meet safety and legal requirements; and for marketing and promotional purposes. Sometimes, we may ask our John Deere affiliates, dealers, or business partners to do work for us, which involves personal information. For complete details on privacy rights and to obtain a copy of the John Deere Privacy Statement, visit our website at <https://www.deere.com/or> <https://www.deere.ca/>.

Warranty Duration

Unless otherwise provided in writing by John Deere, John Deere makes the following warranty to the first retail purchaser and each subsequent purchaser (if purchase is made prior to the expiration of applicable warranty) of each John Deere new off-highway engine marketed as part of a product manufactured by a company other than John Deere or its affiliates and on each John Deere engine used in an off-highway repower application:

- 12 months, unlimited hours of use, or
- 24 months and before the accumulation of 2000 hours of use

NOTE: In the absence of a functional hourmeter, hours of use are determined on the basis of 12 hours of use per calendar day.

Warranty Coverage

This warranty applies to the engine and to integral components and accessories sold by John Deere, and delivered to the first retail purchaser on or after 1 May 2010.

All John Deere-warranted parts and components of John Deere engines which, as delivered to the purchaser, are defective in materials and/or workmanship will be repaired or replaced, as John Deere elects. Warrantable repairs will be made without charge for parts or engine repair labor, including reasonable labor costs to remove and reinstall non-engine parts or components of the equipment in which the engine is installed. If necessary, reasonable labor costs for engine removal and reinstallation will also be included. All coverage is based on the defect appearing within the warranty period as measured from the date of delivery to the first retail purchaser.

Obtaining Warranty Service

Warranty service must be requested of the nearest authorized John Deere engine service outlet before the expiration of the warranty. An *authorized* service outlet is a John Deere engine distributor, a John Deere engine service dealer, or a John Deere equipment dealer selling and servicing equipment with an engine of the type covered by this warranty. (See When Warranty Service is Needed.)

Authorized service outlets will use only new or remanufactured parts or components furnished or approved by John Deere.

NOTE: Authorized engine service locations are listed on the Internet at <https://www.deere.com/or> <https://www.deere.ca/> (click on "Find a Dealer").

At the time of requesting warranty service, the purchaser must be prepared to present evidence of the date of delivery of the engine.

John Deere reimburses authorized service outlets for limited travel expenses incurred in making warranty service repairs in non-John Deere applications when travel is performed. The limit, as of the date of publication of this booklet, is US\$400.00 (US\$500.00 if engine is marine) or equivalent. **If distances and travel times are greater than reimbursed by John Deere, the service outlet will charge the purchaser for the difference.**

Warranty Exclusions

John Deere's obligations will not apply to components and accessories that are not furnished or installed by John Deere, nor to failures caused by such items, except as required by law.

Purchaser's Responsibilities

The cost of normal maintenance and depreciation.

Consequences of negligence, misuse, or accident involving the product, or improper application, installation, or storage.

Consequences of service performed by someone other than an authorized John Deere engine service outlet.

Consequences of any product modification or alteration not approved by John Deere, including, but not limited to, tampering with engine fuel and air delivery systems.

Consequences of failure of non-product components.

Consequences of fuels, lubricants, or coolants that fail to meet the specifications and requirements listed in the Operator's Manual.

The effects of cooling system neglect as manifested in cylinder liner or cylinder block cavitation ("pitting", "erosion", "electrolysis").

Any premium for overtime labor requested by the purchaser.

Costs of transporting the product or the equipment in which it is installed to and from the location at which the warranty service is performed, if such costs are in excess of the travel reimbursement payable to the dealer had the warranty service been performed at the product's location.

Costs incurred in gaining access; for example, overcoming physical barriers such as walls, fences, floors, decks, or similar structures impeding access to the product, rental of cranes or similar, or construction of ramps or lifts or protective structures for product removal and reinstallation.

Incidental travel costs including meals, lodging, and similar, and any travel time or mileage costs in excess of the maximum allowance.

Service outlet costs incurred in solving or attempting to solve non-warrantable problems.

Services performed by a party other than an authorized John Deere service dealer.

Charges by dealers for initial start-up and inspection deemed unnecessary by John Deere when an Operator's Manual is supplied with the product are followed.

Costs related to interpretation or translation services.

No Representations or Implied Warranty

Where permitted by law, neither John Deere nor any company affiliated with it makes any guaranties, warranties, conditions, representations or promises, express or implied, oral or written, as to the nonoccurrence of any defect or the quality of performance of its engines other than those set forth in this booklet, and DOES NOT MAKE ANY IMPLIED WARRANTY OR CONDITIONS OF MERCHANTABILITY OR FITNESS otherwise provided for in the Uniform Commercial Code or required by any Sale of Goods Act or any other statute. This exclusion includes fundamental terms. In no event will a John Deere engine distributor or engine service dealer, John Deere equipment dealer, or John Deere or any company affiliated with John Deere be liable for incidental or consequential damages or injuries including, but not limited to, loss of profits, loss of crops, rental of substitute equipment or other commercial loss, damage to the equipment in which the engine is installed or for damage suffered by purchaser as a result of fundamental breaches of contract or breach of fundamental terms, unless such damages or injuries are caused by the gross negligence or intentional acts of the foregoing parties.

Remedy Limitation

The remedies set forth in this warranty are the purchaser's exclusive remedies in connection with the performance of, or any breach of guaranty, condition, or warranty in respect of new John Deere engines. In the event the warranty fails to correct purchaser's performance problems caused by defects in workmanship and/or materials, purchaser's exclusive remedy shall be limited to payment by John Deere of actual damages in an amount not to exceed the cost of the engine.

No Seller's Warranty

No person or entity, other than John Deere, who sells the engine or product in which the engine has been installed makes any guaranty or warranty of its own on any engine warranted by John Deere unless it delivers to the purchaser a separate written guaranty certificate specifically guaranteeing the engine, in which case John Deere shall have no obligation to the purchaser. Neither original equipment manufacturers, engine or equipment distributors, engine or equipment dealers, nor any other person or entity, has any authority to make any representation or promise on behalf of John Deere or to modify the terms or limitations of this warranty in any way.

Replacement Parts Warranty

John Deere and John Deere Reman parts and components (excluding replacement engines) installed during engine warranty service are warranted for the remaining warranty period of the engine or the applicable warranty term for the installed service part, whichever is greater. A new or remanufactured engine replacing a failed engine under warranty is warranted for 90 days or the remaining warranty period of the original engine, whichever is greater.

Warranty Transfer

The remainder of the original engine warranty and the emissions control-related warranty may be transferred to a subsequent owner of the engine. The Engine Warranty Transfer card should be used to report the transfer to John Deere. If a card is not available, contact your Dealer or simply send the following Information to JDPS Warranty Administration at Diesel-US@JohnDeere.com.

1. The complete 13-character engine serial number.
2. The name and mailing address of the original purchaser.
3. Delivery date to the original purchaser.
4. Hours at the time of transfer.
5. Date of transfer to the new owner.
6. Name and mailing address of the new owner.
7. How the engine/drivetrain being used, that is, what equipment it powers, by manufacturer and model.
8. Equipment it powers, by manufacturer and model.

Purchased Extended Warranty

Extended warranty may be purchased on most engines in many areas of the world. John Deere engine distributors and equipment dealers, and dealers of manufacturers using John Deere engines in their products, have details. John Deere may also be contacted at U.S.A. fax number 1-309-749-0816, or in Europe fax number 33.2.38.84.62.66.

Emissions Warranties

Emissions warranties appear in the Operator's Manual furnished with the engine/machine. **(Warning: Statutes providing severe penalties for tampering with emissions controls may apply at the user's location.)** John Deere may also be contacted at U.S.A. fax number 1-309-749-0816; or in Europe fax number 33.2.38.84.62.66.

Local Warranty Requirements

Warranties required by local statutes will be furnished by the seller.

Option Codes (Engine Manufacturing Configuration)

When in need of engine replacement parts, your authorized John Deere service dealer will must know the corresponding "Option Codes" for your engine. The option code label on the engine rocker arm cover may become damaged over time. By recording the four-digit codes when the engine is new, and storing this manual where it can be found when parts are needed, fast, accurate parts ordering and service will be assured. See Engine Option Codes in Section 01.

Should there be a question about an engine option code, note the engine serial number and call 1-800-JDENGINE from the U.S.A. or Canada, or fax U.S.A. number 1-309-749-0816; or E-mail at diesel-us@johndeere.com, Attention: Warranty Administration; or in Europe fax number 33.2.38.84.62.66, or E-mail at saranservice@johndeere.com.

Registering the Engine for Warranty

Completion and submission of the John Deere Engine Warranty Registration form (cut out sheet found in this manual) is important. John Deere will not deny warranty service on an engine within its warranty period if the engine has not been registered. However, registering your engine will assure your servicing dealer that the engine is within the warranty period.

The easiest way to register your engine is via the Internet. Go to website <https://www.johndeere.com/enginewarranty> You can use the sheet in this manual to gather the information needed to register the warranty.

NOTE: Information provided on the form must be legible!

Typing is preferred, but legible handwritten reports are acceptable. "Block" numbers and Roman alphabet letters should be used. For example: 1,2,3,4 and A, B, C, D.

All requested information should be given. Much of it contributes to reports, including those required by governments.

The purchaser's telephone number or E-mail address allows John Deere to make contact should there be questions concerning the registration. The purchaser should sign and date the form.

CM22194,00011A1 -19-10MAY22-3/3

Emissions Control System Certification Label

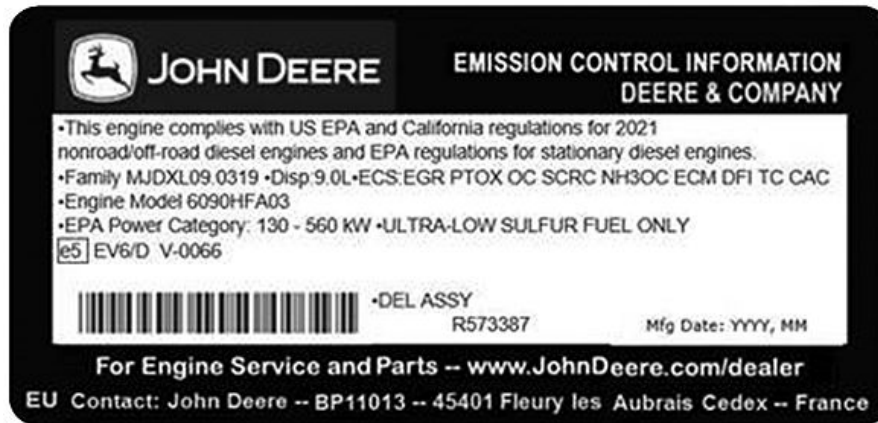

Engine Emissions Label

⚠ CAUTION: Statutes providing severe penalties for tampering with emissions controls may apply to the user or dealer.

The emissions warranty applies to those engines marketed by John Deere that have been certified by the United States Environmental Protection Agency (EPA) and/or California Air Resources Board (CARB); and used in the United States and Canada in Non-road equipment. The presence of an emissions label like the one shown signifies that the engine has been certified with the EPA and/or CARB. The EPA and CARB warranties only apply to new engines having the certification label affixed to the engine and sold as stated above in the geographic areas. The presence of an EU number signifies that the engine has been certified with the European Union countries per Regulation (EU) 2016/1628 and supplementing legislation. The EPA and/or CARB emissions warranties do not apply to the EU countries.

The emissions label has applicable US EPA and/or CARB regulatory year. The regulatory year determines which warranty statement is applicable to engine. See “EPA Non-road Emissions Control Warranty Statement—Compression Ignition” and “CARB Non-road Emissions Control Warranty Statement—Compression Ignition”. For additional regulatory year warranty statements, see www.JohnDeere.com or contact the nearest John Deere service dealer for assistance.

Emission Control System(s) Laws

The U.S. EPA and California ARB prohibit the removal or rendering inoperative of any device or element of design installed on or in engines/equipment in compliance with applicable emission regulations prior to or after the sale and delivery of the engines/equipment to the ultimate purchaser.

DX,EMISSIONS,LABEL -19-05FEB21-1/1

RG33429 —UN—04FEB21

Carbon Dioxide Emissions (CO₂)

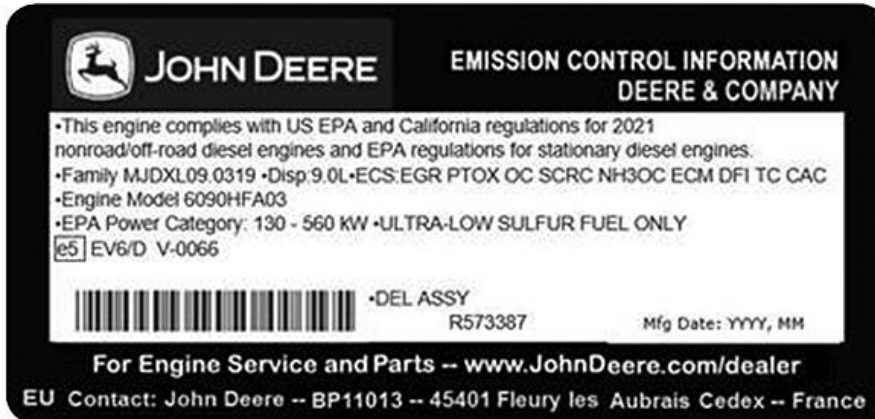

RG33429 —UN—04FEB21

SAMPLE - Engine Emissions Label

To identify the carbon dioxide (CO₂) output, locate the engine emissions label. Find the appropriate family on the emissions label and reference the chart.

representative of the engine type (engine family) and shall not imply or express any guarantee of the performance of a particular engine.

NOTE: The first letter of the family number is not utilized for family identification on the chart.

Emissions Label Family	CO ₂ Result
_JDXL02.9323	952 g/kW-hr
_JDXL02.9327	784 g/kW-hr
_JDXL04.5337	819 g/kW-hr
_JDXL04.5338	682 g/kW-hr
_JDXL04.5304	1004 g/kW-hr
_JDXN04.5174	792 g/kW-hr
_JDXL06.8324	720 g/kW-hr
_JDXL06.8328	683 g/kW-hr
_JDXL06.8336	701 g/kW-hr
_JDXN06.8175	771 g/kW-hr
_JDXL09.0319	646 g/kW-hr
_JDXL09.0325	695 g/kW-hr
_JDXL09.0329	657 g/kW-hr
_JDXL09.0333	650 g/kW-hr
_JDXL13.5326	684 g/kW-hr
_JDXL13.6320	651 g/kW-hr
_JDXL13.5340	632 g/kW-hr
_JDXL18.0341	683 g/kW-hr
F28	870 g/kW-hr
F32	710 g/kW-hr
F33	677 g/kW-hr

This CO₂ measurement results from testing over a fixed test cycle under laboratory conditions a(n) (parent) engine

Continued on next page

DX,EMISSIONS,CO2 -19-20JUL21-1/2

EPA Non-road Emissions Control Warranty Statement—Compression Ignition

DXLOGOV1 —UN—28APR09



JOHN DEERE

U.S. AND CANADA EMISSION CONTROL WARRANTY STATEMENT YOUR WARRANTY RIGHTS AND OBLIGATIONS

To determine if the John Deere engine qualifies for the additional warranties set forth below, look for the "Emissions Control Information" label located on the engine. If the engine is operated in the United States or Canada and the Emissions Control information label states: "This engine complies with US EPA regulations for nonroad and stationary diesel engines", or "This engine conforms to US EPA nonroad compression-ignition regulations", refer to the "U.S. and Canada Emission Control Warranty Statement." If the engine is operated in California, and the label states: "This engine complies with US EPA and CARB regulations for nonroad diesel engines", or "This engine conforms to US EPA and California nonroad compression-ignition emission regulations", also refer to the "California Emission Control Warranty Statement."

Warranties stated on this certificate refer only to emissions-related parts and components of your engine. The complete engine warranty, less emissions-related parts and components, is provided separately. If you have any questions about your warranty rights and responsibilities, you should contact John Deere at 1-319-292-5400.

JOHN DEERE'S WARRANTY RESPONSIBILITY

John Deere warrants to the ultimate purchaser and each subsequent purchaser that this off-road diesel engine including all parts of its emission-control system was designed, built and equipped so as to conform at the time of the sale with Section 213 of the Clean Air Act and is free from defects in materials and workmanship which would cause the engine to fail to conform with applicable US EPA regulations for a period of five years from the date the engine is placed into service or 3,000 hours of operation, whichever first occurs.

Where a warrantable condition exists, John Deere will repair or replace, as it elects, any part or component with a defect in materials or workmanship that would increase the engine's emissions of any regulated pollutant within the stated warranty period at no cost to you, including expenses related to diagnosing and repairing or replacing emission-related parts. Warranty coverage is subject to the limitations and exclusions set forth herein. Emission- related components include engine parts developed to control emissions related to the following:

Air-Induction System
Fuel System
Ignition System
Exhaust Gas Recirculation Systems

Aftertreatment Devices
Crankcase Ventilation Valves
Sensors
Engine Electronic Control Units

EMISSION WARRANTY EXCLUSIONS

John Deere may deny warranty claims for malfunctions or failures caused by:

- Non-performance of maintenance requirements listed in the Operator's Manual
- The use of the engine/equipment in a manner for which it was not designed
- Abuse, neglect, improper maintenance or unapproved modifications or alterations
- Accidents for which it does not have responsibility or by acts of God

The off-road diesel engine is designed to operate on diesel fuel as specified in the Fuels, Lubricants and Coolants section in the Operators Manual. Use of any other fuel can harm the emissions control system of the engine/equipment and is not approved for use.

To the extent permitted by law John Deere is not liable for damage to other engine components caused by a failure of an emission-related part, unless otherwise covered by standard warranty.

THIS WARRANTY IS EXPRESSLY IN LIEU OF ANY OTHER WARRANTIES, EXPRESS OR IMPLIED, INCLUDING ANY WARRANTY OF MERCHANTABILITY OR FITNESS FOR A PARTICULAR PURPOSE. REMEDIES UNDER THIS WARRANTY ARE LIMITED TO THE PROVISIONS OF MATERIAL AND SERVICES AS SPECIFIED HEREIN. WHERE PERMITTED BY LAW, NEITHER JOHN DEERE NOR ANY AUTHORIZED JOHN DEERE ENGINE DISTRIBUTOR, DEALER, OR REPAIR FACILITY OR ANY COMPANY AFFILIATED WITH JOHN DEERE WILL BE LIABLE FOR INCIDENTAL OR CONSEQUENTIAL DAMAGES.

Emission_CI_EPA (18Dec09)

Continued on next page

DX,EMISSIONS,EPA -19-12DEC12-1/2



JOHN DEERE

**U.S. AND CANADA EMISSION CONTROL WARRANTY STATEMENT
YOUR WARRANTY RIGHTS AND OBLIGATIONS**

To determine if the John Deere engine qualifies for the additional warranties set forth below, look for the "Emissions Control Information" label located on the engine. If the engine is operated in the United States or Canada and the Emissions Control information label states: "This engine complies with US EPA regulations for nonroad and stationary diesel engines", or "This engine conforms to US EPA nonroad compression-ignition regulations", refer to the "U.S. and Canada Emission Control Warranty Statement." If the engine is operated in California, and the label states: "This engine complies with US EPA and CARB regulations for nonroad diesel engines", or "This engine conforms to US EPA and California nonroad compression-ignition emission regulations", also refer to the "California Emission Control Warranty Statement."

Warranties stated on this certificate refer only to emissions-related parts and components of your engine. The complete engine warranty, less emissions-related parts and components, is provided separately. If you have any questions about your warranty rights and responsibilities, you should contact John Deere at 1-319-292-5400.

JOHN DEERE'S WARRANTY RESPONSIBILITY

John Deere warrants to the ultimate purchaser and each subsequent purchaser that this off-road diesel engine including all parts of its emission-control system was designed, built and equipped so as to conform at the time of the sale with Section 213 of the Clean Air Act and is free from defects in materials and workmanship which would cause the engine to fail to conform with applicable US EPA regulations for a period of five years from the date the engine is placed into service or 3,000 hours of operation, whichever first occurs.

Where a warrantable condition exists, John Deere will repair or replace, as it elects, any part or component with a defect in materials or workmanship that would increase the engine's emissions of any regulated pollutant within the stated warranty period at no cost to you, including expenses related to diagnosing and repairing or replacing emission-related parts. Warranty coverage is subject to the limitations and exclusions set forth herein. Emission-related components include engine parts developed to control emissions related to the following:

Air-Induction System	Aftertreatment Devices
Fuel System	Crankcase Ventilation Valves
Ignition System	Sensors
Exhaust Gas Recirculation Systems	Engine Electronic Control Units

EMISSION WARRANTY EXCLUSIONS

John Deere may deny warranty claims for malfunctions or failures caused by:

- Non-performance of maintenance requirements listed in the Operator's Manual
- The use of the engine/equipment in a manner for which it was not designed
- Abuse, neglect, improper maintenance or unapproved modifications or alterations
- Accidents for which it does not have responsibility or by acts of God

The off-road diesel engine is designed to operate on diesel fuel as specified in the Fuels, Lubricants and Coolants section in the Operators Manual. Use of any other fuel can harm the emissions control system of the engine/equipment and is not approved for use.

To the extent permitted by law John Deere is not liable for damage to other engine components caused by a failure of an emission-related part, unless otherwise covered by standard warranty.

THIS WARRANTY IS EXPRESSLY IN LIEU OF ANY OTHER WARRANTIES, EXPRESS OR IMPLIED, INCLUDING ANY WARRANTY OF MERCHANTABILITY OR FITNESS FOR A PARTICULAR PURPOSE. REMEDIES UNDER THIS WARRANTY ARE LIMITED TO THE PROVISIONS OF MATERIAL AND SERVICES AS SPECIFIED HEREIN. WHERE PERMITTED BY LAW, NEITHER JOHN DEERE NOR ANY AUTHORIZED JOHN DEERE ENGINE DISTRIBUTOR, DEALER, OR REPAIR FACILITY OR ANY COMPANY AFFILIATED WITH JOHN DEERE WILL BE LIABLE FOR INCIDENTAL OR CONSEQUENTIAL DAMAGES.

Emission_CI_EPA (18Dec09)

TS1721—UN—15JUL13

DX,EMISSIONS,EPA -19-12DEC12-2/2

CARB Non-road Emissions Control Warranty Statement—Compression Ignition

Emissions Control Warranty Statement 2019 through 2021

DXLOGOV1 —UN—28APR09



JOHN DEERE

CALIFORNIA EMISSIONS CONTROL WARRANTY STATEMENT YOUR WARRANTY RIGHTS AND OBLIGATIONS

To determine if the John Deere engine qualifies for the additional warranties set forth below, look for the "Emission Control Information" label located on the engine. If the engine is operated in the United States or Canada and the engine label states: "This engine complies with US EPA regulations for nonroad and stationary diesel engines", or "This engine complies with US EPA regulations for stationary emergency diesel engines", refer to the "U.S. and Canada Emission Control Warranty Statement." If the engine is operated in California, and the engine label states: "This engine complies with US EPA and CARB regulations for nonroad diesel engines" also refer to the "California Emissions Control Warranty Statement."

Warranties stated on this certificate refer only to emissions-related parts and components of your engine. The complete engine warranty, less emission-related parts and components, is provided separately. If you have any questions about your warranty rights and responsibilities, you should contact John Deere at 1-319-292-5400.

CALIFORNIA EMISSIONS CONTROL WARRANTY STATEMENT:

The California Air Resources Board (CARB) is pleased to explain the emission-control system warranty on 2019 through 2021 off-road diesel engines. In California, new off-road engines must be designed, built and equipped to meet the State's stringent anti-smog standards. John Deere must warrant the emission control system on your engine for the periods of time listed below provided there has been no abuse, neglect or improper maintenance of your engine.

Your emission control system may include parts such as the fuel injection system and the air induction system. Also included may be hoses, belts, connectors and other emission-related assemblies.

John Deere warrants to the ultimate purchaser and each subsequent purchaser that this off-road diesel engine was designed, built, and equipped so as to conform at the time of sale with all applicable regulations adopted by CARB and is free from defects in materials and workmanship which would cause the failure of a warranted part to be identical in all material respects to the part as described in John Deere's application for certification for a period of five years from the date the engine is delivered to an ultimate purchaser or 3,000 hours of operation, whichever occurs first for all engines rated at 19 kW and greater. In the absence of a device to measure hours of use, the engine shall be warranted for a period of five years.

EMISSIONS WARRANTY EXCLUSIONS:

John Deere may deny warranty claims for failures caused by the use of an add-on or modified part which has not been exempted by the CARB. A modified part is an aftermarket part intended to replace an original emission-related part which is not functionally identical in all respects and which in any way affects emissions. An add-on part is any aftermarket part which is not a modified part or a replacement part.

In no event will John Deere, any authorized engine distributor, dealer, or repair facility, or any company affiliated with John Deere be liable for incidental or consequential damage.

Continued on next page

DX,EMISSIONS,CARB -19-26AUG20-1/8

Warranty

JOHN DEERE'S WARRANTY RESPONSIBILITY:

Where a warrantable condition exists, John Deere will repair or replace, as it elects, your off-road diesel engine at no cost to you, including diagnosis, parts or labor. Warranty coverage is subject to the limitations and exclusions set forth herein. The off-road diesel engine is warranted for a period of five years from the date the engine is delivered to an ultimate purchaser or 3,000 hours of operation, whichever occurs first. The following are emissions-related parts:

Air Induction System

- Intake manifold
- Turbocharger
- Charge air cooler

Fuel Metering system

- Fuel injection system

Exhaust Gas Recirculation

- EGR valve

Catalyst or Thermal Reactor Systems

- Catalytic converter
- Exhaust manifold

Emission control labels

Particulate Controls

- Any device used to capture particulate emissions
- Any device used in the regeneration of the capturing system
- Enclosures and manifolding
- Smoke Puff Limiters

Positive Crankcase Ventilation (PCV) System

- PCV valve
- Oil filler cap

Advanced Oxides of Nitrogen (NOx) Controls

- NOx absorbers and catalysts

SCR systems and urea containers/dispensing systems

Miscellaneous Items used in Above Systems

- Electronic control units, sensors, actuators, wiring harnesses, hoses, connectors, clamps, fittings, gasket, mounting hardware

Any warranted emissions-related part scheduled for replacement as required maintenance is warranted by John Deere for the period of time prior to the first scheduled replacement point for the part. Any warranted emissions-related part not scheduled for replacement as required maintenance or scheduled only for regular inspection is warranted by John Deere for the stated warranty period.

OWNER'S WARRANTY RESPONSIBILITIES:

As the off-road diesel engine owner you are responsible for the performance of the required maintenance listed in your Operator's Manual. John Deere recommends that the owner retain all receipts covering maintenance on the off-road diesel engine, but John Deere cannot deny warranty solely for the lack of receipts or for the owner's failure to ensure the performance of all scheduled maintenance. However, as the off-road diesel engine owner, you should be aware that John Deere may deny you warranty coverage if your off-road diesel engine or a part has failed due to abuse, neglect, improper maintenance or unapproved modifications.

The off-road diesel engine is designed to operate on diesel fuel as specified in the Fuels, Lubricants and Coolants section in the Operators Manual. Use of any other fuel may result in the engine no longer operating in compliance with applicable emissions requirements.

The owner is responsible for initiating the warranty process, and should present the machine to the nearest authorized John Deere dealer as soon as a problem is suspected. The warranty repairs should be completed by the authorized John Deere dealer as quickly as possible.

Emissions regulations require the customer to bring the unit to an authorized servicing dealer when warranty service is required. As a result, John Deere is NOT liable for travel or mileage on emissions warranty service calls.

Emission_CI_CARB (01Feb17)

Continued on next page

DX,EMISSIONS,CARB -19-26AUG20-2/8

Emissions Control Warranty Statement 2019 through 2021

DXLOGOV1 —UN—28APR09



JOHN DEERE

**CALIFORNIA EMISSIONS CONTROL WARRANTY STATEMENT
YOUR WARRANTY RIGHTS AND OBLIGATIONS**

To determine if the John Deere engine qualifies for the additional warranties set forth below, look for the "Emission Control Information" label located on the engine. If the engine is operated in the United States or Canada and the engine label states: "This engine complies with US EPA regulations for nonroad and stationary diesel engines", or "This engine complies with US EPA regulations for stationary emergency diesel engines", refer to the "U.S. and Canada Emission Control Warranty Statement." If the engine is operated in California, and the engine label states: "This engine complies with US EPA and CARB regulations for nonroad diesel engines" also refer to the "California Emissions Control Warranty Statement."

Warranties stated on this certificate refer only to emissions-related parts and components of your engine. The complete engine warranty, less emission-related parts and components, is provided separately. If you have any questions about your warranty rights and responsibilities, you should contact John Deere at 1-319-292-5400.

CALIFORNIA EMISSIONS CONTROL WARRANTY STATEMENT:

The California Air Resources Board (CARB) is pleased to explain the emission-control system warranty on 2019 through 2021 off-road diesel engines. In California, new off-road engines must be designed, built and equipped to meet the State's stringent anti-smog standards. John Deere must warrant the emission control system on your engine for the periods of time listed below provided there has been no abuse, neglect or improper maintenance of your engine.

Your emission control system may include parts such as the fuel injection system and the air induction system. Also included may be hoses, belts, connectors and other emission-related assemblies.

John Deere warrants to the ultimate purchaser and each subsequent purchaser that this off-road diesel engine was designed, built, and equipped so as to conform at the time of sale with all applicable regulations adopted by CARB and is free from defects in materials and workmanship which would cause the failure of a warranted part to be identical in all material respects to the part as described in John Deere's application for certification for a period of five years from the date the engine is delivered to an ultimate purchaser or 3,000 hours of operation, whichever occurs first for all engines rated at 19 kW and greater. In the absence of a device to measure hours of use, the engine shall be warranted for a period of five years.

EMISSIONS WARRANTY EXCLUSIONS:

John Deere may deny warranty claims for failures caused by the use of an add-on or modified part which has not been exempted by the CARB. A modified part is an aftermarket part intended to replace an original emission-related part which is not functionally identical in all respects and which in any way affects emissions. An add-on part is any aftermarket part which is not a modified part or a replacement part.

In no event will John Deere, any authorized engine distributor, dealer, or repair facility, or any company affiliated with John Deere be liable for incidental or consequential damage.

Continued on next page

DX,EMISSIONS,CARB -19-26AUG20-3/8

RG29280 —UN—02FEB17

Warranty

JOHN DEERE'S WARRANTY RESPONSIBILITY:

Where a warrantable condition exists, John Deere will repair or replace, as it elects, your off-road diesel engine at no cost to you, including diagnosis, parts or labor. Warranty coverage is subject to the limitations and exclusions set forth herein. The off-road diesel engine is warranted for a period of five years from the date the engine is delivered to an ultimate purchaser or 3,000 hours of operation, whichever occurs first. The following are emissions-related parts:

Air Induction System

- Intake manifold
- Turbocharger
- Charge air cooler

Fuel Metering system

- Fuel injection system

Exhaust Gas Recirculation

- EGR valve

Catalyst or Thermal Reactor Systems

- Catalytic converter
- Exhaust manifold

Emission control labels

Particulate Controls

- Any device used to capture particulate emissions
- Any device used in the regeneration of the capturing system
- Enclosures and manifolding
- Smoke Puff Limiters

Positive Crankcase Ventilation (PCV) System

- PCV valve
- Oil filler cap

Advanced Oxides of Nitrogen (NOx) Controls

- NOx absorbers and catalysts

SCR systems and urea containers/dispensing systems

Miscellaneous Items used in Above Systems

- Electronic control units, sensors, actuators, wiring harnesses, hoses, connectors, clamps, fittings, gasket, mounting hardware

Any warranted emissions-related part scheduled for replacement as required maintenance is warranted by John Deere for the period of time prior to the first scheduled replacement point for the part. Any warranted emissions-related part not scheduled for replacement as required maintenance or scheduled only for regular inspection is warranted by John Deere for the stated warranty period.

OWNER'S WARRANTY RESPONSIBILITIES:

As the off-road diesel engine owner you are responsible for the performance of the required maintenance listed in your Operator's Manual. John Deere recommends that the owner retain all receipts covering maintenance on the off-road diesel engine, but John Deere cannot deny warranty solely for the lack of receipts or for the owner's failure to ensure the performance of all scheduled maintenance. However, as the off-road diesel engine owner, you should be aware that John Deere may deny you warranty coverage if your off-road diesel engine or a part has failed due to abuse, neglect, improper maintenance or unapproved modifications.

The off-road diesel engine is designed to operate on diesel fuel as specified in the Fuels, Lubricants and Coolants section in the Operators Manual. Use of any other fuel may result in the engine no longer operating in compliance with applicable emissions requirements.

The owner is responsible for initiating the warranty process, and should present the machine to the nearest authorized John Deere dealer as soon as a problem is suspected. The warranty repairs should be completed by the authorized John Deere dealer as quickly as possible.

Emissions regulations require the customer to bring the unit to an authorized servicing dealer when warranty service is required. As a result, John Deere is NOT liable for travel or mileage on emissions warranty service calls.

Emission_CI_CARB (01Feb17)

Continued on next page

DX,EMISSIONS,CARB -19-26AUG20-4/8

RG29281 —UN—27FEB17

Emissions Control Warranty Statement 2022 through 2024

DXLOGOV1 —UN—28APR09



JOHN DEERE

CALIFORNIA EMISSIONS CONTROL WARRANTY STATEMENT YOUR WARRANTY RIGHTS AND OBLIGATIONS

To determine if the John Deere engine qualifies for the additional warranties set forth below, look for the "Emission Control Information" label located on the engine. If the engine is operated in the United States or Canada and the engine label states: "This engine complies with US EPA regulations for nonroad and stationary diesel engines", or "This engine complies with US EPA regulations for stationary emergency diesel engines", refer to the "U.S. and Canada Emission Control Warranty Statement." If the engine is operated in California, and the engine label states: "This engine complies with US EPA and California regulations for nonroad/off-road diesel engines" also refer to the "California Emissions Control Warranty Statement."

Warranties stated on this certificate refer only to emissions-related parts and components of your engine. The complete engine warranty, less emission-related parts and components, is provided separately. If you have any questions about your warranty rights and responsibilities, you should contact John Deere at 1-319-292-5400.

CALIFORNIA EMISSIONS CONTROL WARRANTY STATEMENT:

The California Air Resources Board (CARB) is pleased to explain the emission-control system warranty on 2022 through 2024 off-road diesel engines. In California, new off-road engines must be designed, built and equipped to meet the State's stringent anti-smog standards. John Deere must warrant the emission control system on your engine for the periods of time listed below provided there has been no abuse, neglect or improper maintenance of your engine.

Your emission control system may include parts such as the fuel injection system and the air induction system. Also included may be hoses, belts, connectors and other emission-related assemblies.

John Deere warrants to the ultimate purchaser and each subsequent purchaser that this off-road diesel engine was designed, built, and equipped so as to conform at the time of sale with all applicable regulations adopted by CARB. John Deere warrants that this engine is free from defects in materials and workmanship which would cause the failure of emissions warranted parts to be identical in all material respects to the part as described in John Deere's application for certification for a period of five years from the date the engine is delivered to an ultimate purchaser or 3,000 hours of operation, whichever occurs first. This applies to all engines rated at 19 kW and greater. In the absence of a device to measure hours of use, the engine shall be warranted for a period of five years.

EMISSIONS WARRANTY EXCLUSIONS:

John Deere may deny warranty claims for failures caused by the use of an add-on or modified part which has not been exempted by the CARB. A modified part is an aftermarket part intended to replace an original emission-related part which is not functionally identical in all respects and which in any way affects emissions. An add-on part is any aftermarket part which is not a modified part or a replacement part.

In no event will John Deere, any authorized engine distributor, dealer, or repair facility, or any company affiliated with John Deere be liable for incidental or consequential damage.

Continued on next page

DX,EMISSIONS,CARB -19-26AUG20-5/8

Warranty

JOHN DEERE'S WARRANTY RESPONSIBILITY:

Where a warrantable condition exists, John Deere will repair or replace, as it elects, your off-road diesel engine at no cost to you, including diagnosis, parts or labor. Warranty coverage is subject to the limitations and exclusions set forth herein. The off-road diesel engine is warranted for a period of five years from the date the engine is delivered to an ultimate purchaser or 3,000 hours of operation, whichever occurs first. The following are emissions-related parts:

Air Induction System

- Intake manifold
- Turbocharger
- Charge air cooler

Fuel Metering system

- Fuel injection system

Exhaust Gas Recirculation

- EGR valve

Catalyst or Thermal Reactor Systems

- Catalytic converter
- Exhaust manifold

Emission control labels

Particulate Controls

- Any device used to capture particulate emissions
- Any device used in the regeneration of the capturing system
- Enclosures and manifolding
- Smoke Puff Limiters

Positive Crankcase Ventilation (PCV) System

- PCV valve
- Oil filler cap

Advanced Oxides of Nitrogen (NOx) Controls

- NOx absorbers and catalysts

SCR systems and urea containers/dispensing systems

Miscellaneous Items used in Above Systems

- Electronic control units, sensors, actuators, wiring harnesses, hoses, connectors, clamps, fittings, gasket, mounting hardware

Any warranted emissions-related part scheduled for replacement as required maintenance is warranted by John Deere for the period of time prior to the first scheduled replacement point for the part. Any warranted emissions-related part not scheduled for replacement as required maintenance or scheduled only for regular inspection is warranted by John Deere for the stated warranty period.

OWNER'S WARRANTY RESPONSIBILITIES:

As the off-road diesel engine owner you are responsible for the performance of the required maintenance listed in your Operator's Manual. John Deere recommends that the owner retain all receipts covering maintenance on the off-road diesel engine, but John Deere cannot deny warranty solely for the lack of receipts or for the owner's failure to ensure the performance of all scheduled maintenance. However, as the off-road diesel engine owner, you should be aware that John Deere may deny you warranty coverage if your off-road diesel engine or a part has failed due to abuse, neglect, improper maintenance or unapproved modifications.

The off-road diesel engine is designed to operate on diesel fuel as specified in the Fuels, Lubricants and Coolants section in the Operators Manual. Use of any other fuel may result in the engine no longer operating in compliance with applicable emissions requirements.

The owner is responsible for initiating the warranty process, and should present the machine to the nearest authorized John Deere dealer as soon as a problem is suspected. The warranty repairs should be completed by the authorized John Deere dealer as quickly as possible.

Emissions regulations require the customer to bring the unit to an authorized servicing dealer when warranty service is required. As a result, John Deere is NOT liable for travel or mileage on emissions warranty service calls.

Emission_CI_CARB (14Apr20)

Continued on next page

DX,EMISSIONS,CARB -19-26AUG20-6/8

Emissions Control Warranty Statement 2022 through 2024

DXLOGOV1 —UN—28APR09



JOHN DEERE

**CALIFORNIA EMISSIONS CONTROL WARRANTY STATEMENT
YOUR WARRANTY RIGHTS AND OBLIGATIONS**

To determine if the John Deere engine qualifies for the additional warranties set forth below, look for the "Emission Control Information" label located on the engine. If the engine is operated in the United States or Canada and the engine label states: "This engine complies with US EPA regulations for nonroad and stationary diesel engines", or "This engine complies with US EPA regulations for stationary emergency diesel engines", refer to the "U.S. and Canada Emission Control Warranty Statement." If the engine is operated in California, and the engine label states: "This engine complies with US EPA and California regulations for nonroad/off-road diesel engines" also refer to the "California Emissions Control Warranty Statement."

Warranties stated on this certificate refer only to emissions-related parts and components of your engine. The complete engine warranty, less emission-related parts and components, is provided separately. If you have any questions about your warranty rights and responsibilities, you should contact John Deere at 1-319-292-5400.

CALIFORNIA EMISSIONS CONTROL WARRANTY STATEMENT:

The California Air Resources Board (CARB) is pleased to explain the emission-control system warranty on 2022 through 2024 off-road diesel engines. In California, new off-road engines must be designed, built and equipped to meet the State's stringent anti-smog standards. John Deere must warrant the emission control system on your engine for the periods of time listed below provided there has been no abuse, neglect or improper maintenance of your engine.

Your emission control system may include parts such as the fuel injection system and the air induction system. Also included may be hoses, belts, connectors and other emission-related assemblies.

John Deere warrants to the ultimate purchaser and each subsequent purchaser that this off-road diesel engine was designed, built, and equipped so as to conform at the time of sale with all applicable regulations adopted by CARB. John Deere warrants that this engine is free from defects in materials and workmanship which would cause the failure of emissions warranted parts to be identical in all material respects to the part as described in John Deere's application for certification for a period of five years from the date the engine is delivered to an ultimate purchaser or 3,000 hours of operation, whichever occurs first. This applies to all engines rated at 19 kW and greater. In the absence of a device to measure hours of use, the engine shall be warranted for a period of five years.

EMISSIONS WARRANTY EXCLUSIONS:

John Deere may deny warranty claims for failures caused by the use of an add-on or modified part which has not been exempted by the CARB. A modified part is an aftermarket part intended to replace an original emission-related part which is not functionally identical in all respects and which in any way affects emissions. An add-on part is any aftermarket part which is not a modified part or a replacement part.

In no event will John Deere, any authorized engine distributor, dealer, or repair facility, or any company affiliated with John Deere be liable for incidental or consequential damage.

Continued on next page

DX,EMISSIONS,CARB -19-26AUG20-7/8

RC32768 —UN—19AUG20

Warranty

JOHN DEERE'S WARRANTY RESPONSIBILITY:

Where a warrantable condition exists, John Deere will repair or replace, as it elects, your off-road diesel engine at no cost to you, including diagnosis, parts or labor. Warranty coverage is subject to the limitations and exclusions set forth herein. The off-road diesel engine is warranted for a period of five years from the date the engine is delivered to an ultimate purchaser or 3,000 hours of operation, whichever occurs first. The following are emissions-related parts:

Air Induction System

- Intake manifold
- Turbocharger
- Charge air cooler

Fuel Metering system

- Fuel injection system

Exhaust Gas Recirculation

- EGR valve

Catalyst or Thermal Reactor Systems

- Catalytic converter
- Exhaust manifold

Emission control labels

Particulate Controls

- Any device used to capture particulate emissions
- Any device used in the regeneration of the capturing system
- Enclosures and manifolding
- Smoke Puff Limiters

Positive Crankcase Ventilation (PCV) System

- PCV valve
- Oil filler cap

Advanced Oxides of Nitrogen (NOx) Controls

- NOx absorbers and catalysts

SCR systems and urea containers/dispensing systems

Miscellaneous Items used in Above Systems

- Electronic control units, sensors, actuators, wiring harnesses, hoses, connectors, clamps, fittings, gasket, mounting hardware

Any warranted emissions-related part scheduled for replacement as required maintenance is warranted by John Deere for the period of time prior to the first scheduled replacement point for the part. Any warranted emissions-related part not scheduled for replacement as required maintenance or scheduled only for regular inspection is warranted by John Deere for the stated warranty period.

OWNER'S WARRANTY RESPONSIBILITIES:

As the off-road diesel engine owner you are responsible for the performance of the required maintenance listed in your Operator's Manual. John Deere recommends that the owner retain all receipts covering maintenance on the off-road diesel engine, but John Deere cannot deny warranty solely for the lack of receipts or for the owner's failure to ensure the performance of all scheduled maintenance. However, as the off-road diesel engine owner, you should be aware that John Deere may deny you warranty coverage if your off-road diesel engine or a part has failed due to abuse, neglect, improper maintenance or unapproved modifications.

The off-road diesel engine is designed to operate on diesel fuel as specified in the Fuels, Lubricants and Coolants section in the Operators Manual. Use of any other fuel may result in the engine no longer operating in compliance with applicable emissions requirements.

The owner is responsible for initiating the warranty process, and should present the machine to the nearest authorized John Deere dealer as soon as a problem is suspected. The warranty repairs should be completed by the authorized John Deere dealer as quickly as possible.

Emissions regulations require the customer to bring the unit to an authorized servicing dealer when warranty service is required. As a result, John Deere is NOT liable for travel or mileage on emissions warranty service calls.

Emission_CI_CARB (14Apr20)

DX,EMISSIONS,CARB -19-26AUG20-8/8

RG32759—UN—19AUG20

China Emission Control Warranty Statement



JOHN DEERE

CHINA EMISSION CONTROL WARRANTY STATEMENT YOUR WARRANTY RIGHTS AND OBLIGATIONS

To determine if the John Deere engine qualifies for the additional warranties set forth below, look for the "Emissions Control Information" label located on the engine. If the engine is operated in China and the Emissions Control Information label contains an Information Disclosure number, refer to the "China Emission Control Warranty Statement".

Warranties stated on this certificate refer only to emissions-related parts and components of your engine. The complete engine warranty, less emissions-related parts and components, is provided separately. If you have any questions about your warranty rights and responsibilities, you should contact John Deere at 400-6576-555.

JOHN DEERE'S WARRANTY RESPONSIBILITY:

John Deere warrants to the ultimate purchaser and each subsequent purchaser that this off-road diesel engine including all parts of its emission-control system was designed, built and equipped so as to conform at the time of sale with GB20891-2014 and HJ1014-2020 and is free from defects in materials and workmanship which would cause the engine to fail to conform with applicable China regulations for a period of five years from the date the engine is placed into service or 3,000 hours of operation, whichever first occurs.

Where a warrantable condition exists, John Deere will repair or replace, as it elects, any part or component with a defect in materials or workmanship that would increase the engine's emissions of any regulated pollutant within the stated warranty period at no cost to you, including expenses related to diagnosing and repairing or replacing emission-related parts. Warranty coverage is subject to the limitations and exclusions set forth herein. Emission-related components include engine parts developed to control emissions related to the following:

Air-induction system	Aftertreatment devices
Fuel System	Sensors
Exhaust gas recirculation systems	Electronic control units

EMISSION WARRANTY EXCLUSIONS:

John Deere may deny warranty claims for malfunctions or failures caused by:

- Non-performance of maintenance requirements listed in the Operator's Manual.
- The use of the engine / equipment in a manner for which it was not designed.
- Abuse, neglect, improper maintenance or unapproved modifications or alterations.
- Accidents for which it does not have responsibility or by acts of God.

The off-road diesel engine is designed to operate on diesel fuel as specified in the Fuels, Lubricants and Coolants section in the Operators Manual. Use of any other fuel can harm the emissions control system of the engine / equipment and is not approved for use.

To the extent permitted by law John Deere is not liable for damage to other engine components caused by a failure of an emission-related part, unless otherwise covered by standard warranty.

THIS WARRANTY IS EXPRESSLY IN LIEU OF ANY OTHER WARRANTIES, EXPRESS OR IMPLIED, INCLUDING ANY WARRANTY OF MERCHANTABILITY OR FITNESS FOR A PARTICULAR PURPOSE. REMEDIES UNDER THIS WARRANTY ARE LIMITED TO THE PROVISIONS OF MATERIAL AND SERVICES AS SPECIFIED HEREIN. WHERE PERMITTED BY LAW, NEITHER JOHN DEERE NOR ANY AUTHORIZED JOHN DEERE ENGINE DISTRIBUTOR, DEALER, OR REPAIR FACILITY OR ANY COMPANY AFFILIATED WITH JOHN DEERE WILL BE LIABLE FOR INCIDENTAL OR CONSEQUENTIAL DAMAGES.

LX628019 — UN — 10DEC21

Continued on next page

DX,EMISSIONS,NR4 -19-21APR22-1/2



JOHN DEERE

中国排放物控制质保声明 您的质保权利和责任

为了确定约翰迪尔发动机是否符合下述额外质保，请查看发动机的“排放标签”。如果发动机是在中国销售使用并且“排放标签”包含信息公开编号，请参考本声明。

本质保声明只涉及与发动机排放相关的零部件。对于发动机整机以及与非排放相关零部件的质保声明将另行提供。如果您对您的质保权利和责任有任何疑问，请致电 400-6576-555 联系约翰迪尔。

约翰迪尔保修责任

约翰迪尔向最终购买者和每位后续购买者保证：该非道路柴油发动机，包括其排放控制系统的所有零件的设计、制造和配置在销售时均符合《非道路移动机械用柴油机排气污染物排放限值及测量方法（三、四阶段）》（GB20891-2014）和《非道路柴油移动机械污染物排放控制技术要求》（HJ1014-2020）标准的规定，发动机材料无缺陷，在工艺上不会导致不符合中国法规的缺陷。保修期从发动机销售之日起算五年或作业 3000 小时，先到者为准。

如符合质保条件，约翰迪尔将按其选择，修理或者更换任何在材料或工艺存在缺陷，会导致法规规定的发动机排放污染物增加的零部件，在规定的质保期内，您无需支付任何费用，包括与诊断、维修或更换排放相关零部件的费用。保修范围受以下限制和排除条款约束。排放相关的部件包括下列为控制排放物而开发的发动机零件：

进气系统

燃油系统

废气再循环系统

后处理装置

传感器

发动机电子控制单元

排放保修除外条款

约翰迪尔有权拒绝由以下原因引起故障或失效的保修申请：

- 不履行操作手册中列出的维修要求
- 不按设计的方式使用发动机/设备
- 误用、疏忽、不正确的维修或未经批准而进行的修改或改装
- 非因约翰迪尔责任导致的事故或不可抗力引起的事故

该非道路柴油发动机的运行需要使用指定的柴油机燃油。这一点在操作手册中“燃油、润滑油和冷却液”章节中明确规定。任何其它燃油的使用都可能导致发动机/设备的排放控制系统受损，因此不得使用。

在法律允许的范围内，除非标准保修另有规定，否则约翰迪尔对因排放相关零部件故障而导致的其他发动机部件损坏不承担责任。

本质保声明将替代所有其他明示或暗示的保证，包括任何促销性或出于其他目的间接保证。本质保声明所涉及的保修服务仅限于本声明规定的零部件和质保条款。在法律允许的情况下，约翰迪尔或任何约翰迪尔授权的发动机批发商、经销商或维修机构或任何约翰迪尔附属公司均不对间接或后继损失负责。

DX,EMISSIONS,NR4 -19-21APR22-2/2

LX528020—UN—10DEC21

Index

	Page		Page
A			
A/C compressor.....	65-9		
Additional service information.....	65-1		
Aftertreatment indicators overview.....	25-7		
Aftertreatment Serial Number.....	01-4		
Aftertreatment system			
Emergency SCR derate override.....	05-14, 05-15		
Air compressor			
Checking.....	65-9		
Air filter			
Element storage.....	65-6		
Inspect.....	65-6		
Replacement.....	65-5		
Alternator belt.....	65-8		
Automatic (AUTO) Exhaust Filter Cleaning.....	25-8		
Auxiliary gear drive			
Limitations.....	20-7		
Avoid static electricity risk when fueling.....	05-6		
B			
Battery			
Charge/boost.....	20-6		
Battery Handling, Safety			
Safety, Battery Handling.....	05-7		
Biodiesel fuel.....	10-10		
Bolt and screw torque values			
Metric.....	80-6		
Unified inch.....	80-5		
Break-in engine oil			
Interim tier 4, final tier 4, stage IIIB, stage IV, and stage V.....	10-13		
Break-in, engine.....	20-1		
C			
Carbon Dioxide Emissions.....	90-5		
Cleaning Engine.....	70-18		
Compressor, air			
Checking.....	65-9		
Coolant			
Adding.....	65-2		
Diesel engine			
Engine with wet sleeve cylinder liners.....	10-18		
Disposing.....	10-20		
Mixing with concentrate, water quality.....	10-19		
Testing freeze point.....	10-20		
Warm temperature climates.....	10-19		
Coolant pump			
Inspecting.....	40-4		
Cooling system			
Adding coolant.....	65-2		
Check.....	40-8		
Flush.....	60-1		
Pressure test.....	40-9		
Refill.....	60-1		
D			
Daily prestarting checks.....	35-1		
DEF			
DEF tank header suction screen, replace.....	46-1		
Disposal.....	10-7		
Dosing unit filter, change.....	51-1		
In-line filter, change.....	61-1		
Storing.....	10-2		
Tank, cleaning.....	65-3		
Tank, refilling.....	10-6		
Testing.....	10-7		
Use in SCR equipped engines.....	10-1		
DEF dosing unit			
Accessing.....	51-1		
DEF dosing unit filter			
Change.....	51-1		
DEF in-line filter			
Change.....	61-1		
DEF tank			
Cleaning.....	65-3		
DEF Tank Heade			
Accessing.....	46-1		
DEF tank header suction screen			
Replace.....	46-1		
DEF tank inlet screen			
Installation.....	65-10		
Removal.....	65-11		
DG14 Diagnostic Gauge			
Essential Menus.....	15-7		
Main Menu.....	15-6		
Using.....	15-5		
Diagnostic Gauge Keys and Indicators.....	25-6		
Diagnostic trouble codes (DTCs)			
Intermittent fault code diagnostics.....	70-5		
Listing.....	70-2		
Operation.....	70-5		
Diesel engine oil			
Interim tier 4, final tier 4, stage IIIB, stage IV, and stage V.....	10-14		
Diesel engines, cold weather effect.....	10-12		
Diesel Exhaust Fluid (DEF) Tank Fill Cap.....	10-3		
Diesel Exhaust Fluid (DEF) Tank Fill Cap — Installation and Removal.....	10-3		
Diesel fuel.....	10-8		
Supplemental additives.....	10-9		
Diesel fuel, testing.....	10-11		
Diesel Particulate Filter			
Maintenance and Service.....	25-2		
Disable Exhaust Filter Cleaning.....	25-9		
E			
Effect of cold weather on diesel engines.....	10-12		
Electrical connections.....	65-9		

Continued on next page

	Page		Page
Emission system		System overview	25-3
Certification label	90-4		
Emissions		F	
Required language		Fan belt.....	65-8
EPA	30-1	Checking belt wear	40-7
Emissions Performance		Checking spring tension.....	40-8
Tampering	-4	Filter, replace	
Engine		Oil.....	40-3
Adding coolant	65-2	Filters	
Adjust speed	40-10	Exhaust	
Break-in.....	20-1	Ash handling and disposal	25-2
Changing speed.....	20-5	Cleaning	25-1
Check ground connection	40-10	Cleaning and maintenance.....	25-1
Cold weather operation.....	20-4	Disposal.....	25-2
Daily prestarting checks.....	35-1	Indicators.....	25-6
Idling	20-5	Passive regeneration.....	25-8
Normal operation	20-3	Service required	25-10
Starting.....	20-2	System overview	25-3
Stopping.....	20-6	Filters, Oil	
Troubleshooting	70-6	Oil Filters.....	10-17
Warming.....	20-5	Fire extinguisher, service.....	40-1
Engine Control Unit (ECU) serial number.....	01-5	Fuel	
Engine coolant		Biodiesel	10-10
Disposing of	10-20	Diesel	10-8
Engine mounts		Handling and storing	10-9
Checking	40-10	Lubricity.....	10-9
Engine oil		Fuel Filters	
Break-In		Drain water.....	65-2
Interim tier 4, final tier 4, stage IIIB, stage IV, and stage V	10-13	Filters, Fuel	10-11
Change	40-3	Fuel pump model number.....	01-4
Diesel		Fuel system	
Interim tier 4, final tier 4, stage IIIB, stage IV, and stage V	10-14	Bleeding.....	65-9
Service intervals.....	10-16	Fuels, lubricants and coolant.....	30-1
Engine oil and filter service intervals		Fuses	
Interim tier 4, final tier 4, stage IIIB, stage IV, and stage V		Checking	65-9
OEM applications	10-15		
Engine oil filter		G	
Service intervals.....	10-16	Generator set (standby) applications.....	20-1
Engine speed		Glow plugs	
Changing.....	20-5	Test	50-4
Engine wiring layout	70-19		
Exhaust Filter.....	25-9	H	
Maintenance and service	25-2	Hardware torque values	
Exhaust Filter cleaning	25-8	Metric	80-6
Exhaust Filter Cleaning	65-7	Unified inch	80-5
Exhaust Filter Cleaning Disable	25-9		
Exhaust Filter Service Required	25-10	I	
Exhaust Filters		Identification views	-6
Ash handling and disposal	25-2	Indicators overview.....	25-7
Cleaning.....	25-1	Instrument panels	
Cleaning and maintenance	25-1	John Deere PowerSight.....	15-13
Disposal	25-2	Intermittent DTC diagnostics	70-5
Indicators	25-6		
Passive regeneration	25-8		
Service required.....	25-10		

Continued on next page

	Page		Page
J		Service interval chart	30-2
John Deere PowerSight.....	15-13	Lubrication and Maintenance	
L		1500 Hours/36 Months	
Long-term storage		Accessing DEF Tank Header	46-1
Preparing engine.....	75-2	Lubrication and maintenance records	85-1
Removing from.....	75-3	1500 hours	85-2
Lubricant		1500 hours or 36 months.....	85-2
Mixing.....	10-16	3000 hours or 36 months.....	85-2
Lubricant Storage		500 hours or 12 months.....	85-1
Storage, Lubricant.....	10-16	6000 hours or 72 months.....	85-3
Lubricants, safety	10-16	Daily prestarting checks.....	85-1
Lubrication and maintenance		Service as required.....	85-3
1500 hours		Lubricity of diesel fuel	10-9
Changing open crankcase vent (OCV) filter.....	45-1	M	
Replace DEF tank header suction screen.....	46-1	Machine stop warning, required	15-11
1500 Hours/36 Months		Maintenance interval chart	30-2
Accessing DEF dosing unit	51-1	Manual Exhaust Filter Cleaning.....	25-9
3000 hours/36 months		Metric bolt and screw torque values	80-6
Adjusting valve clearance.....	50-1	Mixing lubricants.....	10-16
Testing glow plugs.....	50-4	O	
500 hours/12 months		Oil	
Changing Engine Oil and Filter	40-3	Engine	
Changing Fuel Filters	40-5	Interim tier 4, final tier 4, stage IIIB,	
Checking and adjusting engine speeds.....	40-10	stage IV, and stage V	10-14
Checking Belt Wear.....	40-7	Fill quantity.....	80-4
Checking cooling system.....	40-8	Filter change.....	40-3
Checking engine ground connection	40-10	Open crankcase vent (OCV)	
Checking open crankcase vent (OCV).....	40-5	Checking.....	40-5
Checking Tensioner Spring Tension.....	40-8	Operating engine	
Checking engine mounts.....	40-10	Break-in.....	20-1
Inspecting coolant pump	40-4	Changing speed.....	20-5
Pressure testing cooling system.....	40-9	Cold weather.....	20-4
Servicing battery.....	40-1	Normal operation	20-3
Servicing fire extinguisher	40-1	Stopping engine	20-6
6000 hours/72 months		Warming engine.....	20-5
Flushing and refilling cooling system.....	60-1	Operating Engine	
Testing thermostat opening temperature.....	60-3	Idling	20-5
As required		P	
Adding coolant.....	65-2	Parked Exhaust Filter Cleaning	25-9
Additional service information	65-1	Passive Regeneration	25-8
Air filter element storage	65-6	Pre start cleaning	
Bleeding fuel system	65-9	Guide	65-4
Checking air compressors.....	65-9	Precautions for welding	
Checking electrical wiring and connections.....	65-9	Welding.....	70-23
Checking fuses.....	65-9	PV101 Diagnostic Gauge	
Checking refrigerant (A/C) compressor.....	65-9	Essential Menus.....	15-5
Cleaning DEF tank	65-3	Main Menu	15-4
Drain water from fuel filters	65-2	Using.....	15-3
Inspecting primary air filter element	65-6	PV101 Instrument Panel	
Pre-start cleaning guide	65-4	Component function.....	15-1
Replacing air filter element.....	65-5		
Replacing fan belt.....	65-8		
Daily			
Prestarting checks.....	35-1		

Continued on next page

	Page		Page
Troubleshooting			
DTC Operation	70-5		
Engine	70-6		
General information	70-1		
Intermittent DTC diagnostics	70-5		
Listing DTCs	70-2		
		U	
Unified inch bolt and screw torque values	80-5		
		V	
Valves			
Adjusting clearance	50-1		
		W	
		Warranty	
		Information and registration	-3
		Non-road emissions control warranty statement--compression ignition	
		CARB	90-8
		EPA	90-6
		OEM applications	90-1
		Wiring connections	65-9

