

Single Band receiver based on TCA440 (K174XA2) (40m, 80m or 160m)

- Working range: 40, 80 or 160 meters (only one band supported)
- Core of the receiver: K174XA2
- Operation: SSB
- Power supply: 9V

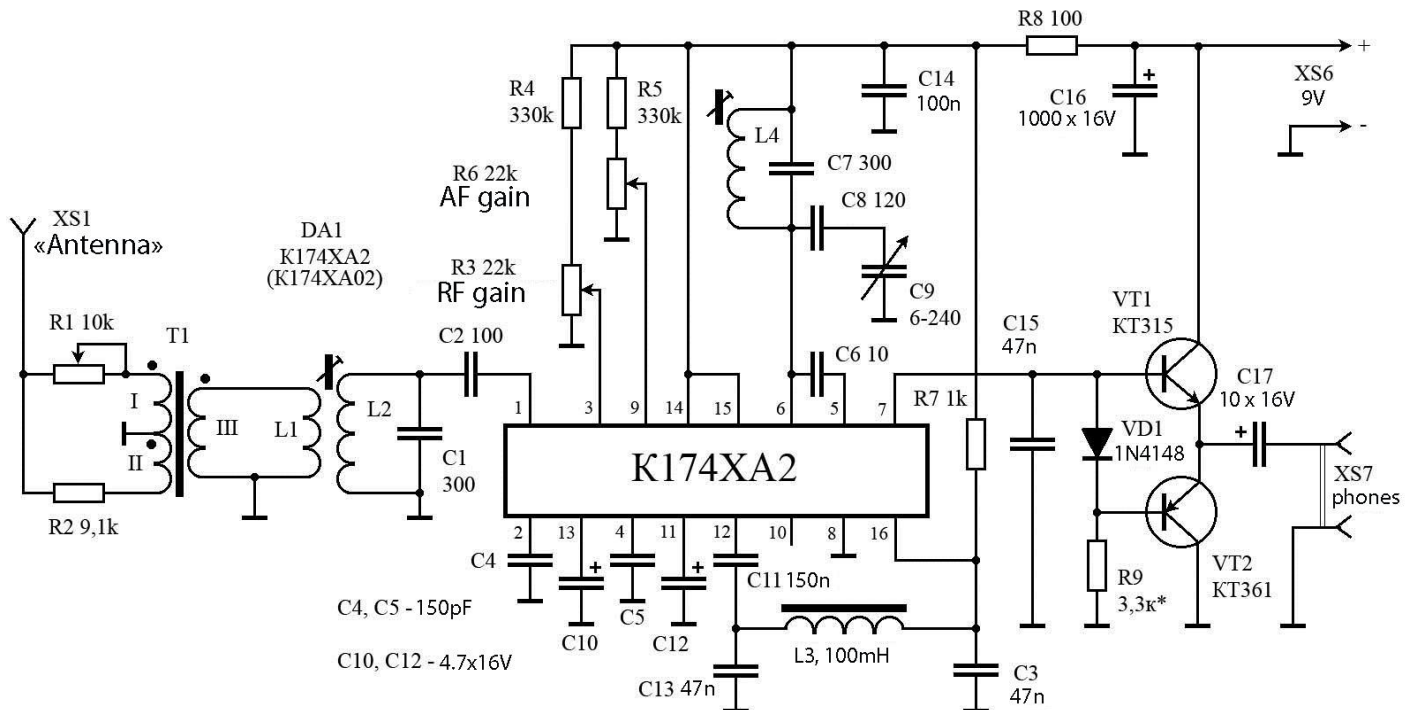

Working description

The diagram of the heterodyne receiver based on K174XA2 shown below. The signal from antenna is going to the attenuator R1, R2, T1 and further through the coil L1 to the input circuit L2C1. Attenuator is designed as a bridge circuit – minimum signal to the input of the receiver receives in case of equality of resistances R1 and R2. The signal from L2C1 is going through a capacitor C2 to the RF amplifier of K174XA2. Another input of RF amplifier "grounded" through a capacitor C3.

A variable resistor R3 regulates the gain of RF amplifier. The local oscillator of the receiver contains only a few external components – coil L3 and capacitors C7, C8 and C9. RF amplifier and local oscillator inside K174XA2 are connected to the inputs of the balanced mixer based on four transistors. In the collector circuit of one pair of transistors included resistor R7, which is allocated sound frequency equal to the frequency difference signal and the local oscillator. The variable resistor R6 allows tune the AF gain.

Assembly Details

- The transformer T1 is wound on ferrite coil 10x6x5. Winding: **three twisted** wires 0.28 mm, 7-9 turns. The beginning of first wire connects to the end of second wire, forming a middle output of the transformer.
- Low-pass filter is standard 100mH toroid (in a kit). Also it could be built on toroid 17x8x5. Wire 0.1mm. 260 turns. Inductance ~100-130 mH. Or find out the magnetic head from an old tape recorder. It is also having 100-130mH.
- The pinout for Russian diode KД522 and transistors KT315-KT361 are on the picture below. Follow to the labeling on PCB.

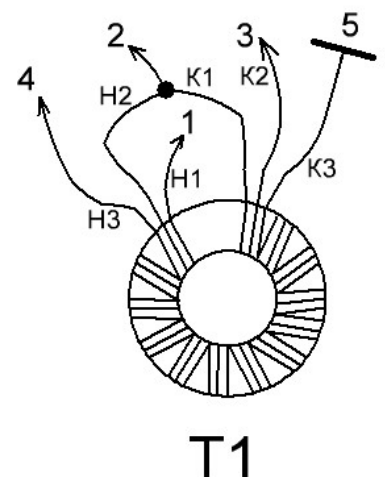

T1

Band	L2 & L4	L1 (above L2)	Wire	Inductance L2, L4 (with screen & 1/2 core)	Capacitors C1, C7
1,9 MHz	50 turns	9 turns	0,16 mm	~14,9 μ H	470 pF
3,5 MHz	34 turns	6 turns	0,16 mm	~8,5 μ H	240 pF
7 MHz	24 turns	4 turns	0,16 mm	~4,3 μ H	120 pF

Adjustment

The adjustment of the receiver is extremely simple and comes down to configuring two loops (L2, C1, L1 and L4) to the frequency 160 meters. If you have frequency generator, then connect it to the antenna input and tune the core of coil L4 to set the desired receiving frequency. Reducing the level of the signal from the frequency generator, configure the circuit L2, C1, L1, to achieve the maximum volume. In the absence of frequency generator – all the same procedures can be done by taking signals from radio stations.

The adjustment of AF based on transistors VT1 and VT2 by selection of resistor R9. Its resistance should be such that the

voltage at the emitters of transistors was equal to half the supply voltage. The quiescent current of the AF (in the absence of a signal) should not exceed 1-2 mA. At higher current, you should check the serviceability of transistors and diode VD1. AF load is headphones with impedance of 50 - 60 Ohms.

The receiver works well with an indoor antenna – cut the wire a few meters long, but for reception of distant stations it is better to use “long wire” antenna.

