

RADIO SHOW PREVIEW



Vol. 28. No. 551
SEPTEMBER, 1952

EDITOR:
F.J. CAMM

PRACTICAL WIRELESS

The



**ELECTRONIC
ORGAN**



IN THIS ISSUE :

A DIRECT-READING BRIDGE
A BENCH POWER PACK
SHORT-WAVE SECTION
"SURPLUS" TUNING INDICATORS



A CHEAP WATTMETER
DUAL-WAVE CRYSTAL
DESIGNING THE OUTPUT STAGE
TRANSMITTING TOPICS

? KNOWN OR UNKNOWN ?

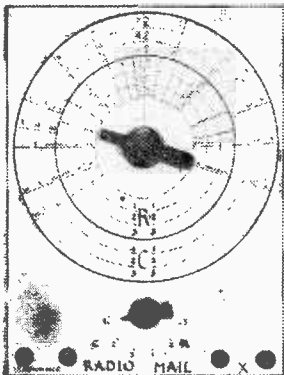

**RESISTORS
CONDENSERS
ACCURATELY
INDICATED
DIRECT
ON DIAL
30/- ONLY**

THE RADIO MAIL RES./CAP. BRIDGE KIT IS THE BEST RADIO VALUE OBTAINABLE TO-DAY

5 megohms—50,000 ohms	50 mfd.—2 mfd.
100,000 ohms—1,000 ohms	1 mfd.—.01 mfd.
1,000 ohms—10 ohms	.01 mfd.—.0005 mfd. (500 pF.)

NO CALIBRATING. An accurately calibrated panel with each kit. As illustrated.

NEW COMPONENTS. Specially selected for accuracy.

EASILY ASSEMBLED. Instructions, circuit and diagrams.

RADIO MAIL, 4, RALEIGH ST., NOTTINGHAM
Stamp for list and with all enquiries, please

**SENSATIONAL
TAPE RECORDING INVENTION
By QUALTAPE ENGINEERS**

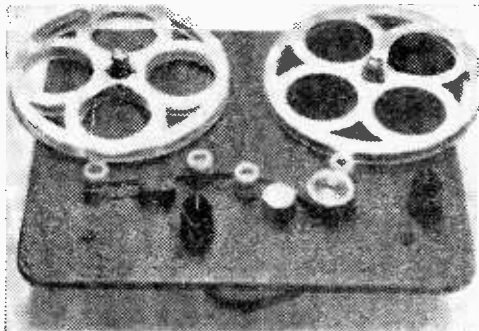

Your Radio or Radio Gramophone can now be used in conjunction with the Qualtape Deck and Pre-amplifier. Radio and Records faithfully and perfectly recorded, without use of Microphone and whilst listening. Reproduction is guaranteed equal to your radio. Microphone jack is provided for other purposes. Wow is non-existent. Post Card brings illustrated brochure and details of all Qualtape manufactures. Demonstrations by appointment.
Price: £13 13 0

Address: **DEPT. P.A.
ELECTRONIC SERVICE (HALLAMSHIRE) LTD.
BUTTON LANE, SHEFFIELD.**
Telephone: Sheffield 21690

*"The incomparable
GP 20 crystal pick-up
is generally
available again..."
THAT'S GOOD TO HEAR!
always well ahead*

COSMOCORD LIMITED · ENFIELD · MIDDLESEX

SOUTHERN RADIO'S WIRELESS BARGAINS

WALKIE-TALKIE TRANSMITTER-RECEIVER. Type 38 Mark II. Complete with 5 valves. Throat Microphone. Headphones and Aerial. 7 mcs. Amateur Band suitable for field use. Powerful Superhet Receiver. Modulated Transmitter. Guaranteed ready for the Air, less batteries. £4.12.6.

TYPE 18 TRANSMITTERS. 6-9 mc s. Perfect. £7.10.-.
R109-8 VALVES SHORT-WAVE RECEIVERS, enclosed speaker and vibrator pack for 6 volts 1.8-8.5 mcs., complete in metal case. £7.15.-.

G.E.C. "MINISCOPE" M8618. MINIATURE CATHODE RAY 498 TELESCOPES. 1 1/2 in. Tube. Time Base, etc., etc. Brand New in Maker's Sealed Carbons with Leatherette Carrying Case—£25.10.- plus 5/- carriage.

LUFBRA HOLE CUTTERS. Adjustable from 1/4 in. to 3/16 in. for use on Wood, Metal, Plastic, etc., 5/9. **LUFBRA FLY CUTTERS,** 14/6.

THROAT MICROPHONES. Magnetic type complete with long lead and plug. 4/6.

PLASTIC TRANSPARENT MAP CASES. 14in. by 10 1/2 in. Ideal for Maps, Charts, Display, Photographs, etc., 5/6.

STAR IDENTIFIERS. With Hydrographic Office Modifications A-N Type 1. Complete in case. 5/6.

WESTECTORS. Type WX6 and W112. 1/- ea., 11/- doz.
MARCONI AERIAL FILTER UNITS. Type "916" in conformity with P.O. Specification. Full instructions for fixing. 4/-.

CONTACTOR TIME SWITCHES. 10-hour movement. 2 impulses per second. Thermostatic Control in soundproof Cases. 11/6.

VISUAL INDICATOR UNIT Type 3 (10Q 4). Contains two Moving Coil movements, two Neons, etc. Easily convertible to very efficient M.C. Meters, 11/- Conversion fully described in "W.W." Sept., 1951.

RESISTANCES. 100 Assorted values. Wire-ended 1-2 watts. 12.6 per 100.

CONDENSERS. 100 Assorted Tubular and Mica—up to 2 mfd., 15/- per 100.

Full list of Radio Publications, 21d.

**SOUTHERN RADIO SUPPLY LTD.,
11, LITTLE NEWPORT ST., LONDON, W.C.2**
GERard 6653.

The new **ARMSTRONG** Television Chassis Model T.V.15

incorporating a 12in. C.R.T., is now available for distribution

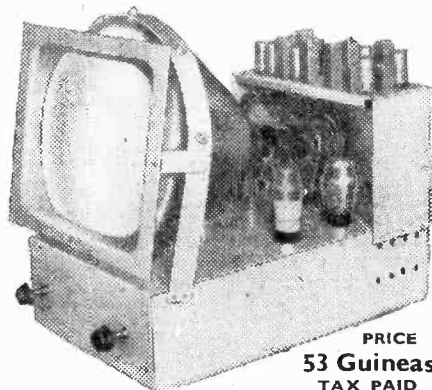

PRICE
53 Guineas
TAX PAID

Available shortly

The new **T.V.25 TELEVISION CHASSIS** with 15in. CATHODE RAY TUBE and 10in. P.M. Loudspeaker Comprehensive Maintenance Service available. **PRICE 60 Guineas Tax Paid.**

Please send for Radiogram and T.V. list, post free.

ARMSTRONG WIRELESS & TELEVISION CO., LTD.,
WALTERS ROAD, HOLLOWAY, LONDON, N.7.
Telephone—NORTH 3213.

Another page from the **DENCO** catalogue

I. F. TRANSFORMER IFT.11 465 Kc/s.

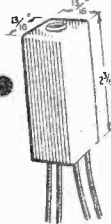

We are exhorted to combat higher wages by greater efficiency in order to keep down the cost. So far as radio and technical quality is concerned this is a problem! **BUT WE HAVE SUCCEEDED**... and here it is. Our new I.F. Transformer has: Litz Iron Core Adjustment. Four coloured round coils. Silver Mica Condensers. PVC lead out wires (which saves you time in soldering and cost of material). **YET COSTS ONLY 12/- per pr.** Retail. Ask your dealer for our catalogue (9d.). (Or 1/- direct from us.)

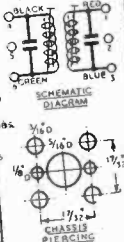
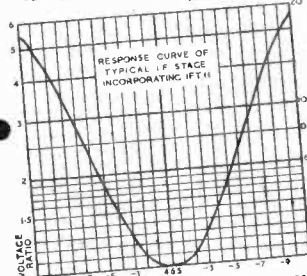

DENCO (CLACTON) LIMITED,
357/9, Old Road, Clacton-on-Sea, Essex.

TALLON CABINETS

for the

VIEW MASTER
ELECTRONIC ENGINEERING & PRACTICAL TELEVISION SETS
MINI-FOUR ARGUS
P.W. 3-SPEED AUTOGRAM

In pack-flat kits or assembled cabinets. Radiogram, Radio and Television or combination cabinets made to suit customer's requirements, in quantities or singly. Tape Recorder Cabinets. Prices and literature on application
Mini-four Cabinet, Blue Leathercloth, complete with grille and plastic handle ... 14/- incl. postage

JAMES TALLON & SONS LTD.
(Dept. P.W.1)

MANOR WORKS . MANOR ROAD
RUGBY
Telephone : RUGBY 2070

The solder for all HOME TELEVISION CONSTRUCTOR SETS

Designers of television constructor sets know that the efficiency of their equipment depends on the solder used by the constructor—that's why they recommend Ersin Multicore for trouble-free, waste-free soldering. Ersin Multicore, the only solder containing three cores of extra-active, non-corrosive Ersin Flux, is obtainable from all leading radio shops. Ask for Cat. Ref. C.16018, 18 S.W.G. 60/40 High Tin Television and Radio Alloy. The size 1 Carton contains 37 feet of solder, costs 5/-.



Ersin Multicore Solder

In case of difficulty in obtaining supplies, please write to:
MULTICORE SOLDERS LTD., MULTICORE WORKS, MAYLANDS AVE., HEMEL HEMPSTEAD, HERTS. • Boxmoor 3636 (3 lines).

The "PRACTICAL WIRELESS" MINI FOUR BATTERY PORTABLE

A 4-valve battery superhet receiver designed to receive 4 Pre-Set Stations, three on medium waveband and one on long waves to suit local conditions. Each station is obtained on the set by the turn of a rotary switch. No tuning is necessary.

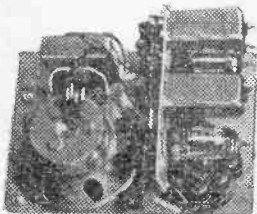

It is of midget size, being only 4 1/2 in. x 6 1/2 in. x 4 1/2 in. when completely built, and is very easily assembled from diagrams supplied. Cost of all components to completely build the set, including a drilled and cut chassis and panel, and new valves, £9/10/0 (for less valves for £6/7/6). Plus Portable Carrying Case, 16/6. A blue print showing complete practical component layout and wiring diagram, together with an individual component price list, is available separately, 1/6. Our Mains Units available in kit form are suitable for use with this set.

THE "WIRELESS WORLD" 3-VALVE SET

A Midget 3-valve T.R.F. Receiver for operation on A.C. mains, covering long and medium wavebands. We are able to supply all of the components to build this set, as designed, and specified in the Feb. 1950 issue, including the drilled chassis, valves and moving coil speaker, etc., at the following prices: To construct complete chassis, less dial and drive assembly, £5/5/0. Ditto, including dial and drive assembly, £6. To construct the complete set, including dial and drive assembly and cabinet, £7/3/0. Overall size of cabinet is 7 1/2 in. x 5 1/2 in. x 1 1/2 in. A reprint of the designer's article, giving Circuit and Assembly Instructions (this is available separately for 9d.), together with a Practical Component Layout is included with each of above assemblies.



A QUALITY "PUSH-PULL" AMPLIFIER KIT

A Kit of Parts to build a 6-8 watt Push-Pull Amplifier for operation on A.C. mains 200-250 volts. Incorporates a simple arrangement to enable either a magnetic, crystal, or lightweight pick-up to be used.

A 10-watt Output Transformer is designed to match from 2 to 15 ohm speakers. Tone control is incorporated. The overall size of the assembled chassis is 10 in. x 8 in. x 7 1/2 in. high. Price of kit complete in every detail, including drilled chassis and valves, £8/12/6. Component layout is supplied. Price of assembled chassis, supplied ready for use, £8/2/6.

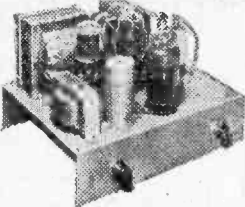

"PERSONAL SET" BATTERY ELIMINATOR

A complete kit of parts to build a Midget "Aldry" Battery Eliminator, giving approx. 69 volts and 1.4 volts. This Eliminator is for use on A.C. mains and is suitable for any 4-valve Superhet Receiver requiring H.T. and L.T. voltage as above, or approx. to 69 volts. The kit is quite easily assembled and is housed in a light aluminium case, size 4 1/2 in. x 1 1/2 in. x 3 1/2 in. Price of complete kit, with easy to follow assembly instructions, 42/6. In addition we can offer a similar COMPLETE KIT to provide approx. 90 volts and 1.4 volts. Size of assembled Unit 7 1/2 in. x 2 1/2 in. x 1 1/2 in. Price 47/6.



★ Send 9d. P.O. for our STOCK LIST, showing many KITS OF PARTS for Sets and Battery Chargers and "hundreds" of Wireless Components. When ordering please include 1/6 to cover cost of postage and packing.

STERN RADIO LTD., 109 & 115, FLEET STREET, E.C.4.

Telephone: CENTRAL 5814 & 2280

How much do you know about **RADIO** and **TELEVISION**?

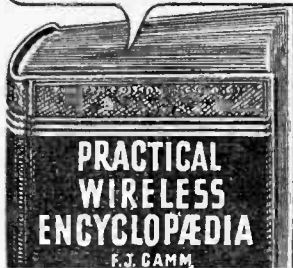

This world-famous book contains all latest radio and television developments. Earlier copies sold 300,000; this entirely new volume has 400 pages, 1,440 entries, hundreds of illustrations, covers every aspect of radio; new sections include radar, television, remote control, oscillators, Kirchoff's laws, photo-electric cells, new series of modern circuits

for receivers and amplifiers, automatic station sel., car radio, electron multipliers, fault finding, building television receiver, new colour codes, etc.—contains all the accumulated knowledge of radio science! Examine this grand book on our 5 days' Approval Terms—if you do not wish to retain it, return and your purchase money is refunded in full!

MAKE SURE OF YOUR COPY—POST COUPON NOW

To: **A. THOMAS & Co. (PW1), 111 Buchanan St. BLACKPOOL**
I enclose 22/- for one copy of above OR Please send C.O.D.

Name

Address

PREPARE NOW

FOR WINTER TV
The NEW 1355 Conversion data for all five Channels.
Only 3/- per copy.

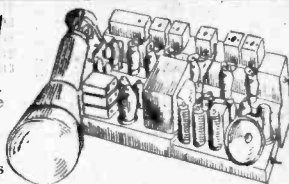

NEW supply of 1355's in original cases, 49/6.

VIBRATOR PACK 21,
delivering 140v at 40 mA from 6v input. "As New" 17/6

ERICSSON'S 'PHONES'
4,000 ohms pair, 17/6 (boxed) 11d. post.

TRANSMITTER 21
for speech, MCW or CW on 4.2-7.5 or 18-31 mc/s; PA coils and relays, stripped by Ministry, may be replaced with our circuit. With circuit, valves, control box and key. First class condition. 25/-

60v BATTERIES
5/6 each

ACCUMULATORS
multiplate, unspillable, 7AH. 3 1/2 x 1 1/2 x 4ins. 6/6

RECEIVERS
P 40 / S 45 O.B. 4 EF50's (R.F. mixer, LO multipliers, 2 EF39's (2.9 mc/s IF's) (2.9 mc/s (audio).

POWER PACK
with 5Z4, VU120 (5KV) rect, two transformers, choke, etc., with our 200/250 50cps data for EHT or 450v (50ma) H.T. ONLY 17/6

EB34 (det) 6j5 and 6V6 (audio). 85/95 mc/s. NEW and BOXED. 69/6 with circuit. (Post 2/-)

FLASH! Brand New
1155's in original makers' cases. £10 15s.

RADIO EXCHANGE CO.
9 CAULDWELL STREET, BEDFORD
Phone 5568

B.A. SCREWS, NUTS, WASHERS, ETC.

		Prices per gross.			Brass Washers	
		Brass Nuts			Assd. 1/16, OBA 2/1-	
		OBA	Full	Lock	1/8A 2/1-	2BA 1/10
Assd. Screws	2/16	6/9	6/1-	6/1-	3BA 1/9	4BA 1/8
Assd. Nuts	2/16	2BA	5/16	5/1-	5BA 1/6	6BA 1/8
Screws and Nuts	2/16	4BA	5/1-	4/1-	8BA 1/6	
1/2 gr. each	2/16	5BA	4/1-	3/9		
Brass Screws,		5BA	4/1-	3/9		
Assorted		5BA	4/1-	3/6		
2BA 5/16, 4BA 5/1-		7BA	4/16	4/1-		
6BA 4/1-, 8BA 4/16		8BA	4/16	4/1-		

Soldering Tags, Assd. 2/1-. 2BA 2/3, 4BA 2/1-, 6BA 1/10, 8BA 1/10.
 Eyelets and Rivets, assd. 1/16. Aluminium Rivets, assd. 1/16.
 Br. Knurled Terminal Nuts, 6BA 8d., 4BA 1/1-, 2BA 1/6 doz.
 Br. Terminals, w/nuts, heavy type, NP, 6d. each, 5/6 doz.
 GRUB SCREWS, Assd. 1/16, 6BA 1/3, 4BA 1/4, 2BA 1/6 per 3 doz.

A SELECTION FROM OUR HUGE STOCK OF SCREWS.

PRICES PER HALF-GROSS.

ABBREV.: Heads. CH., Cheese. RH., Round. CS., Counter-sunk. NP., Nickel Plated. CP., Cadmium Pl. SC., Self-colour.

6BA		BRASS			STEEL		
CH	NP	1/16	RH	NP	1/16	CH	NP
SC	NP	1/16			1/16	RH	SC
		1/17			1/17	CS	CP
		1/19			1/19	RH	SC
		1/10			1/11	CS	CP
		1/11			2/1-		1/2
		2/1-		SC	2/11	RH	SC
	SC	1/11		NP	2/3	CS	CP
	NP	2/11		CS	1/4		1/5
		2/3		NP	1/6	RH	SC
		2/6			1/7	CS	CP
Inst/H		1/9			1/8	CH	
NP		1/9			1/9		2/6
CS		2/1-			1/10	HIH	2/9

4BA		BRASS			STEEL		
CH	SC	2/1-	RH	NP	1/10	CS	CP
	NP	2/11			2/9		1/4
		2/12			3/1-	RH	SC
		2/16			1/8		1/4
		3/3		CS	2/1-	CS	CP
Hex/H		2/6			2/3	RH	SC
		3/6			1/10	CP	1/9

2BA		BRASS			STEEL		
RH	NP	2/10	CH	NP	4/3	HIHSC	1/9
		3/1-		SC	3/1-	LgeRH	2/1-
		3/3			5/1-	RH	SC
	SC	3/3		RH	4/9	CH	2/6
	NP	4/3		CS	NP	4/1-	RH
Hex/H	SC	10/1-			4/9	CS	2/9
							2/1-

8BA		BRASS			STEEL		
CH	NP	2/1-	CH	SC	2/1-	CH	CP
		2/6		RH	NP	2/2	CS
	CS	1/8			2/6	CH	2/2
	CH	2/3			2/9	RH	2/2
	CS	1/9		Hex	2/9	CH	NP
		2/6			2/10	RH	CP

ALL ABOVE POSTAGE EXTRA.

Manufacturers' enquiries invited, abundant stocks of most items.

Large stocks of Copper and RESISTANCE WIRES; Paxolin type TUBING; Laminated Bakelite and Ebonite PANELS; TUFNOL and EBONITE TUBES and ROD; ERIE and DUBILIER RESISTORS; GERMANIUM and SILICON DIODES.

POST ORDERS ONLY PLEASE.

Send stamp for comprehensive lists. Trade supplied.

POST RADIO SUPPLIES
 33, BOURNE GARDENS,
 LONDON, E.4

Telephone: CLIssoid 4688 & 2021



HERE ARE THE POINTS THAT REALLY COUNT!

1. Fast rewind and forward run—essential for easy cueing.
2. Three motors to obviate use of friction drives so often the cause of "wow" and "flutter".
3. High grade Record Play Back Head with mu-metal laminations and accurate gap to make possible a frequency response of 50 c.p.s. to 10,000 c.p.s. at 7 1/2 in./sec. with a good amplifier.
4. Twin track heads to cut tape costs in half and double recording time per reel.
5. Electro-Magnetic Erase Head for low tape noise and to enable one track to be erased without affecting the other when two recordings are made on a single tape.

The LANE TAPE TABLE

IS THE ONLY MACHINE OFFERING ALL THESE FEATURES

at the Low Price of

£16.10.0

Write for Leaflet and name of nearest Dealer to

VERDIK SALES LTD.

17, Shaftesbury Avenue, London, W.1.

Phone: GERrard 8266

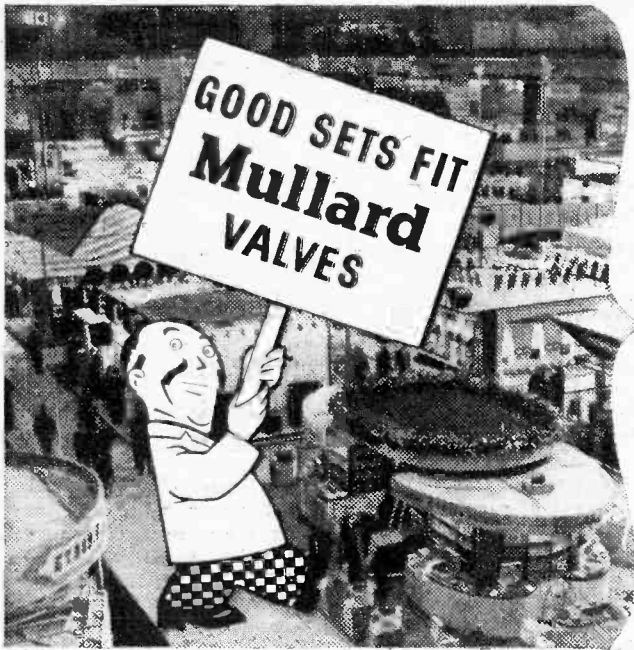

Mullard

VALVES
and
TV TUBES
EARLS COURT
STAND No. 17



MULLARD LTD., CENTURY HOUSE, SHAFTESBURY AVENUE, W.C.2

MVM 203A

*miniature in size...
mighty in performance*



- Pardon us for blowing our own trumpet so loudly but OSMOR "Q" RANGE COILS really do beat the band. No imitations, regardless of price, can compare with them for super selectivity and sensitivity. And you don't just have to take our word for it—the watertight guarantee makes your satisfaction certain! Consider these points of superiority:
- * Only 1in. high.
 - * Variable iron dust cores.
 - * Low loss Polystyrene formers.
 - * Packed in damp-proof containers
 - * Fitted tags for easy connection.

COILPACKS. A full range is available for Superhet and T.R.F. Mains or Battery. Size only 1½in. high x 3½in. wide x 2½in. Ideal for reliable construction of new sets, also for conversion of the 21 RECEIVER, TR.1196, TYPE 18, WAR-TIME UTILITY and others. Aligned and tested, with full circuits, etc. Fully descriptive leaflets available.

MATCHED COMPONENTS. Various types of OSMOR Dials, Chassis, I.F.S. Speakers, Transformers, etc., to match our coils and coilpacks are all listed. Send 5d. (stamps) for FREE CIRCUITS and full lists of coils, coilpacks and radio components.

WARNING! Avoid inferior imitations. Genuine OSMOR Coilpacks are sold only under the name OSMOR.

OSMOR

radio products ltd

(Dept. P.27), BRIDGE VIEW WORKS, BOROUGH HILL, CROYDON, SURREY. Telephone: Croydon 5148/9



Practical Wireless

EVERY MONTH
VOL. XXVIII, No. 551 SEPTEMBER, 1952

Editor F. J. CAMM

20th YEAR
OF ISSUE

COMMENTS OF THE MONTH

By THE EDITOR

Transmitting Licence Amendment

THE Post Office announces that it has decided to amend the licences under which the operators of amateur wireless transmitting stations may transmit from alternative addresses or under portable conditions. A new licence will be available, at a charge of 10s., entitling an amateur to operate for a period of up to one month at a temporary address. This licence is designed to cater for amateurs who wish to carry on their transmitting experiments during annual holidays or at other times when they are away from home.

Alternative Address and Portable Station licences will continue to be available at a charge of 10s. a year, but in their new form they will permit certain additional facilities. For example, the holder of the new licence will be permitted to operate from his alternative address and at another temporary address as well, and he may operate his portable station within five miles of any notified location for a period of 48 hours, provided that in both cases the Post Office Engineering Department has been notified in advance by registered letter or telegram of the particular location. The use of a portable transmitting station on certain inland waters and lakes will also be permitted. This new licence is an experimental measure and the position will be reviewed early next year.

There is an ever-widening interest in amateur transmitting and that is why we regularly feature amateur transmitting topics in this journal.

NATIONAL RADIO TRAINING SCHEME

THE Radio Industry Council, with the approval of the Ministry of Labour, is, as announced elsewhere in this issue, introducing a scheme of training for radio, technical and laboratory assistants which may qualify them for deferment from military service. Under the scheme trainees will register with the Radio Industry Council at the age of 16 or up to 17 and each will be issued with a nationally-recognised certificate on completion of training at the age of 21. The trainee will apply for deferment of military service in the normal way and will be supported in his application by the R.I. Council.

This is the first real effort made by the industry to people the industry with those who are

qualified and trained within it. Somewhat belatedly it is following the system which has become general practice throughout the engineering industries, of which the radio industry is but a small part. It is our view that because of the lack of skill in the radio industry the cost of components and receivers is far too high. The industry grew out of amateurs who, whilst they have excellent technical knowledge, had practically no workshop experience and little knowledge of how to modify a design for production purposes. Many of those have now attained most important positions, but they are still without manufacturing experience. The effect of the new scheme, of course, will not be felt for at least four or five years.

Most leading manufacturers now insist upon training courses for their dealers before agencies are granted, and, whilst the position of radio servicing throughout the country is in need of improvement, the position is far better to-day than it was 10 years ago. The ranks of radio dealers has, to some extent, been purged of the charlatans.

GERMAN RADIO SHOW POSTPONED

THE postponement of the German Radio Show (which was scheduled to take place from August 22nd to August 31st) to February 27th to March 8th, 1953, will enable the German radio industry to display its wares at a time which coincides with the introduction of a chain of television stations throughout Western Germany. This was a wise move, for it will enable television manufacturers to reap the maximum benefit from the publicity given by the exhibition.

SPONSORED TV BROADCASTING

THE first step towards sponsored TV broadcasting in this country has been made. A company has been formed to develop the special equipment which will be needed for a station specialising in commercial broadcasts. The company will provide services in accord with the terms laid out in the Government's White Paper. From the discussions which have taken place on this subject it is clear that these programmes will be unlike the American pattern: rather a diluted version of them.—F. J. C.

ROUND the WORLD of WIRELESS

Broadcast Receiving Licences

THE following statement shows the approximate number of licences issued during the year ended May 31st, 1952.

Region	Number
London Postal ..	2,402,000
Home Counties ..	1,679,000
Midland ..	1,781,000
North Eastern ..	1,963,000
North Western ..	1,654,000
South Western ..	1,087,000
Welsh and Border Counties ..	749,000
Total England and Wales ..	11,315,000
Scotland ..	1,161,000
Northern Ireland ..	213,000
Grand Total ..	12,689,000

Radio Audience Increase in Hungary

A HUNDRED thousand radio relay loudspeakers will be installed in Hungary during 1952, it is announced by the Hungarian postal authorities. In 1951, 45,000 were installed, many of the relay systems being set up in new industrial areas.

In addition, the number of ordinary wireless sets increased by 129,000 during the year ending March, 1952, while the sale of sets in the first quarter of the year was nearly 90 per cent. over that of a year ago.

January marked the biggest monthly average of sales with 30,000 sets, February coming second with 21,000.

Wireless Installations for Yemen

WIRELESS equipment of British design and manufacture will give the Kingdom of Yemen, 74,000 square mile territory on the eastern shore of the Red Sea, a basis for its first permanent internal and external communication system. An order for the equipment has been placed with Marconi's Wireless Telegraph Co. Ltd. by His Majesty the Imam.

The main installations will be at Taiz, an inland town, and at Hodeida on the coast. At Hodeida will be a 100-watt "Oceanspan" transmitter, permitting constant communication with shipping passing through the Red Sea to and from Suez, and two all-frequency receivers for incoming messages

from other countries. At Taiz, Marconi's have already installed a 200-watt transmitter and this equipment will be augmented with two receivers of the same type as installed at Hodeida.

A high-frequency receiver is to be installed for commencement of an internal communications system, and two 100-watt high-frequency transmitters will be placed at other centres to provide subsidiary internal services.

BBC Technical Appointments

AS previously announced, the following appointments have been made in the Technical Services of the BBC and become effective from August 1st, 1952.

Mr. H. Bishop, C.B.E., B.Sc. (Eng.), F.C.G.I., M.I.E.E., M.I.Mech.E., becomes director of Technical Services in succession to Sir Noel Ashbridge, who is retiring.

Mr. R. T. B. Wynn, C.B.E., M.A., M.I.E.E., has been appointed chief engineer in succession to Mr. Bishop.

Mr. F. C. McLean, M.B.E., B.Sc., M.I.E.E., succeeds Mr. Wynn as deputy chief engineer.

Mr. Bishop joined the BBC from Marconi's in 1923 as senior superintendent engineer and became assistant chief engineer in 1929 until 1943, when he was appointed chief engineer. Mr. Wynn became head of the BBC Engineering Information Department in 1926. In 1935 he was appointed senior superintendent engineer and became successively assistant chief engineer in 1943 and deputy chief engineer in 1950. Mr. McLean, who joined the BBC in 1936, became head of Engineering Services Group in 1949 and of the Engineering Projects Group in 1950.

New Ekco Factory

PRODUCTION started recently in a new E. K. Cole Ltd. works near the main factory at Southend-on-Sea only three weeks after taking over the building.

The new building in Kenway Road, Prittlewell, has a total area of 17,000 square feet and a manu-

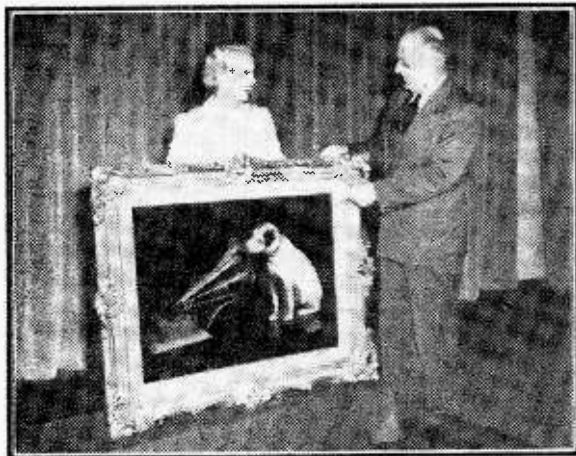

The original "His Master's Voice" trade mark painting which, as mentioned on P. 402, accompanied Mr. J. D. Bicknell, artistes manager for the Gramophone Co. Ltd., to New York recently in connection with the launching of a new H.M.V. record series in America.

facturing area of 14,200 square feet.

Ekco engineers moved in while the builders were still completing the factory shell. In the three weeks at their disposal they modified parts of the building already erected, laid in power supplies to all parts of the factory, built conveyor lines, installed general services, provided fluorescent lighting, erected special test cabins and accommodated stores which were entering the factory before the assembly lines had even been laid down.

Greenland Expedition

THE 25 members of the British North Greenland Expedition who recently left Britain for a 26-months investigation of the ice cap, 800 miles from the North Pole, took with them four new-type high-frequency transmitter-receivers for intercommunication when the group is working as separate units.

The wireless equipment will be fitted to sledges used in traversing ice and snow, and one great advantage is that operating power is generated by a hand crank, so eliminating the need for batteries.

Power is about two watts, two "spot" frequencies on the 2.5-8.5 Mc/s band can be used in operation and a single transmitter-receiving dipole is fitted as an aerial.

The equipment has been designed and manufactured by Marconi's Wireless Telegraph Co. Ltd. and has been loaned to the expedition, which is under the leadership of Commander Courtland J. W. Simpson, D.S.O., R.N.

Glider Walkie-talkies

THE world gliding championships were won by Mr. Philip Wills, and Flt. Lt. R. C. Forbes, R.A.F., was third.

This year, for the first time, the British team used radio-telephone equipment for direct and continuous communication between the airborne gliders and their attendant cars.

In the past, communication between pilots and car crews has been rather limited, but this year requests from the pilots for ground assistance were met quickly and their whereabouts were known to the car crews at all times.

The radio-telephone equipment, which was being loaned by Pye, consisted of (a) one of the new Pye walkie-phones (walkie-talkie) weighing only 8lbs. fitted into each sailplane and (b) a Pye mobile

radio-telephone unit (similar to that installed in London taxis) installed in each of the attendant cars.

**Mr. P. V. Hunter, C.B.E.,
Hon.M.I.E.E.**

THE directors of the British Insulated Callender's Cables Limited announce that they have accepted with regret the resignation of Mr. P. V. Hunter, C.B.E., Hon.M.I.E.E., as a deputy chairman as from August 31st, 1952. At that date Mr. Hunter will be in his 70th year and is desirous of reducing his commitments. He will, however, continue as a non-executive director and at the request of the company will remain on the boards of several of the subsidiary companies where his long experience and technical knowledge are of special value.

R.S.G.B. Amateur Radio Exhibition

THE sixth annual Radio Society of Great Britain Amateur Radio Exhibition, will be opened by Lt.-Col. Sir Ian Fraser, C.B.E., M.P., a past president of the Society, at 12 noon on Wednesday, November 26th, this year.

Sir Ian is the Member of Parliament for the Morecambe Division

of Lancashire and president of the British Legion.

Certificates for Amateurs

THE R.S.G.B. state that the Netherlands National Amateur Radio Society (VERON) is to issue a certificate, to be known as PACC, to any licensed amateur able to give sufficient proof of having been in two-way contact with 100 different Dutch amateur stations since 1946. There are no restrictions and any amateur band may be used. Confirmations should be sent to VERON Traffic Bureau, 77, Middenduinerweg, Santpoort, The Netherlands.

Decca Recordings

DECCA announce that they are producing an album of records entitled: "The Second Elizabeth," a history of modern times, introducing the voices of H.M. King George VI, H.R.H. Duke of Windsor, the Rt. Hon. Winston Churchill, President Roosevelt and many other famous people.

At 45s. including P.T., the album is available in three standard 12in. discs or one 12in. L.P., in a pictorial sleeve with notes.

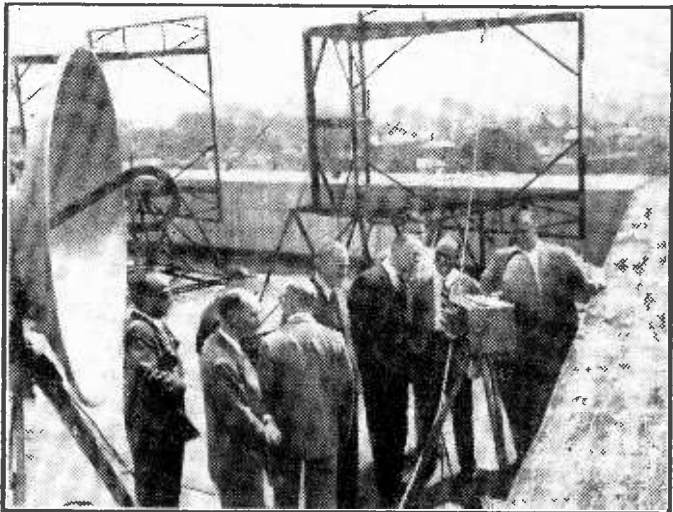

During the Commonwealth Broadcasting Conference recently held in London delegates paid a visit to the works and research laboratories of Marconi's Wireless Telegraph Co. Ltd. at Chelmsford. Right to left: Lt.-Col. Charles Moses, general manager, Australian Broadcasting Commission; Mr. J. P. Gilmour, senior engineer, Canadian Broadcasting Corporation; Mr. R. E. Santo, transmission and development engineer, Canadian Broadcasting Corporation (behind Gilmour); Mr. B. N. MacLarty, deputy chief engineer, Marconi's; Mr. R. T. B. Wynn, deputy chief engineer, BBC; Mr. W. L. Harrison, chief engineer, New Zealand Broadcasting Service.



A PRE-VIEW AND ADVANCE INFORMATION ON SOME OF THE EXHIBITS

DUE to our early press dates it is not possible in this issue to deal with any "surprises" which might appear at this year's Radio Show at Earls Court. As most of our readers know, manufacturers vie with each other in producing something novel or outstanding at the annual exhibition, and in the past some remarkable secrets have been kept right up to the opening hour. Due to our national economy, it is not expected that anything untoward will be revealed this year, unless it be in the field of television and this subject will, of course, be dealt with in our companion paper.

Information released up to the time of going to press indicates that certain interesting lines will be followed in the general design and appearance of radio receivers. With the growth of television the ordinary sound receiver is not having such an appeal to the public, and endeavours to make it more attractive are reflected in the general appearance or material from which the cabinets are made, rather than in the actual circuitry or performance of the receiver. On page 393, for instance, is a radiogram from the Pilot factories, which, whilst it incorporates the sliding drawer idea for the gramophone auto-changer, is finished in a modern light wood. This idea is seen in many modern furnishing houses and is well suited to the up-to-date flat or home. In this particular model (No. R.G.A.61 or R.G.A.63, with three-speed mechanism), the exterior is in walnut veneer, but when opened ready for use all exposed surfaces are seen to be in sycamore, which, with the white control knobs, presents a most pleasing appearance.



Collaro A.C. 3/514 gramophone unit. It is a 3-speed model.

Table Models

In the table models it will be found that the general trend is towards smaller models, generally of the self-contained and A.C./D.C. type. Many of these are also of the battery/mains type and come into the category of the "Personal" receiver. Again, the design will be found to be "modern" and the finish, usually in plastic, very clean and bright.

VISIT OUR STAND No. 52

For the Best Books, Blueprints,
Periodicals & Reader Service

We show a Pilot model illustrating this feature, the receiver being the latest version of the Little Maestro, a 5-valve superhet which has been brought up to date each year now, whilst still possessing its main original features. This particular model is available in brown, cream or green. Some

of these new models have the speaker so placed that the sound is audible on both sides of the cabinet, whilst in at least one instance the tuning and controls are also made available from either side. As these models do not require an external aerial this means that they may be placed on a table in the centre of a room and the programmes may be heard anywhere in the room. The battery supplies make this type of receiver suitable for outdoor use.

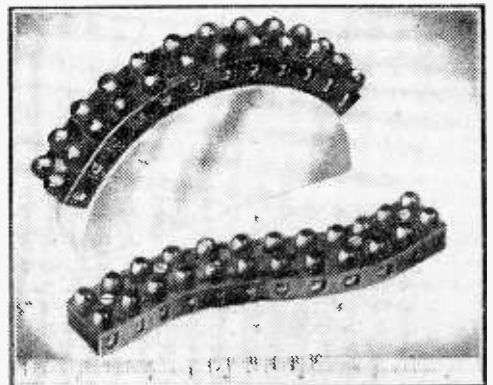

Flexible terminal mounts in the Belling-Lee range.

De-luxe Models

Among the combined or de-luxe types of receiver may be mentioned the McCarthy combined radiogram-television, which has optional F.M. switching for the new high-quality broadcasts if and when they take place. This receiver is of the 8-valve type with gramophone compensating network and push-pull output stage, three wavebands, combined television and F.M. receiver (15-valve circuit) and a triple

illustration shows two mounting positions, and it will be obvious from this that it may be mounted on the most uneven or irregular surface (without fracture). The well-known Belling-Lee terminals and aerial equipment will also be exhibited.

Loudspeakers

A special demonstration room is being taken by Goodmans to demonstrate their high-fidelity speakers, and these may be heard reproducing from tape, disc and radio. Included in this demonstration will be the Axiom 150 Mk. II and the Axiom 22 Mk. II, both of which have a bass resonance of 35 c.p.s. In addition there will be seen for the first time some new elliptical speakers with 7in. x 4in. and 10in. x 6in. cones.

The well-known Stentorian speakers of the Whiteley Electrical Co. will also be demonstrated in a sound-proof room on their stand, and the duplex models which incorporate their own tweeter will undoubtedly attract those who are interested in high quality and do not have the space to mount two separate speakers. There is, of course, also the point which is favoured by many enthusiasts that the sound source becomes one central point with this type of speaker rather than two as when separate speakers are employed. For high powers the 12in. model should be used.

There will be seen the complete range of W.B. speakers from the small 3in. model to P.A. and industrial models.

On this stand will also be seen the special Radio Sonde transmitter used in conjunction with balloons for transmitting weather reports, A.M. and F.M. transmitters and similar equipment.

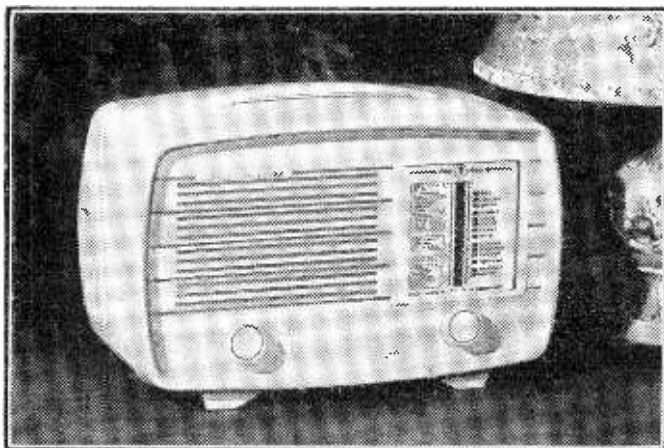

The latest version of the Pilot Little Maestro.

loudspeaker unit with cross-over network. The cabinet houses a built-in horn and shelves for record-storage albums.

Components

No doubt the majority of our readers are more interested in the constructor component market, and most of the well-known names will be found at Earls Court. The Belling-Lee items, for instance, will be found this year to be augmented by certain components which have primarily been produced for the television market, but which will still have application to the normal radio equipment. A valuable item is the thermal-delay switch, one of which is illustrated on page 394, whilst the flexible terminal block will immediately appeal to the experimenter as forming a very useful item for inclusion in certain types of equipment. This is of P.V.C., and the terminal screws are securely gripped by the resilient moulding and cannot be shaken out or dislodged accidentally, even when the block is mounted upside down. The

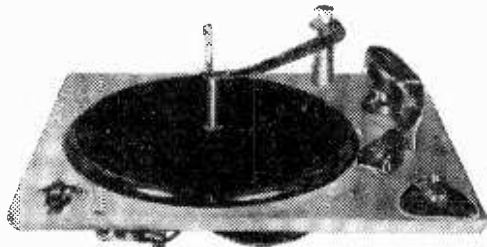

One of the Collaro playing desks.

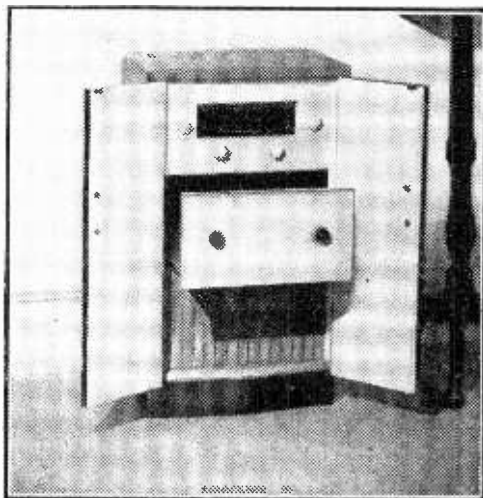

Another Pilot receiver—a radiogram with sycamore panelling inside.

Other Components

Amongst the other components to be seen are the various condensers—mica, ceramic, electrolytic, etc., features by Dubilier and T.C.C. In this connection the novel tester shown opposite should be inspected as it shows how condensers are tested and sorted into relative capacities according to tolerances, and this is only one of the five special machines which T.C.C. are showing.

Special rectifiers, such as the SenTerCel by Standard Telephones and Cables, and the metal rectifiers by Westinghouse company, will attract attention as these are now being produced with much smaller physical dimensions and certain types will withstand overloads which previously could not be tolerated. One particularly interesting item on the Westinghouse stand is a "Transbooster," which is a constant potential rectifier capable of holding a set D.C. output voltage to within limits of plus or minus one per cent., irrespective of variations in load, notwithstanding a mains input voltage variation of plus six or minus four per cent.

On the Stratton stand will be seen the specialised short-wave items and complete receivers which have been popular for years under the "Eddystone"

demonstration will take the form of a section from the Pye factory where engineers will be assembling television camera units. The makers point out that

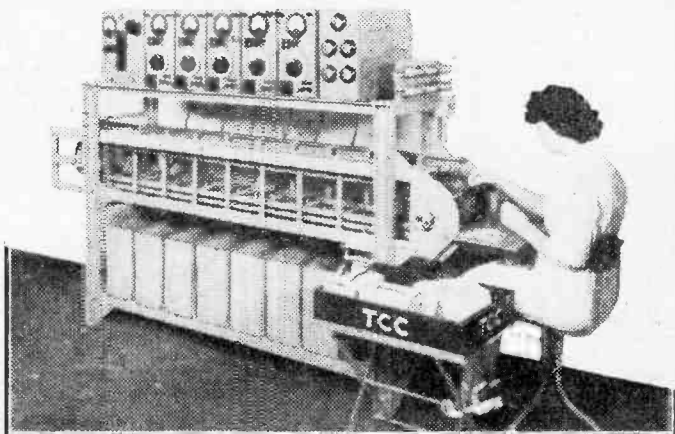

One of the T.C.C. condenser testing machines. See this on Stand No. 72

the manufacture of each camera involves more than 10,000 soldered joints. Some of the equipment which will be made up on this stand at the show will be exported by air to the U.S.A.

New Dry Batteries

Among the batteries will be seen seven popular new all-dry low-tension batteries in attractive new-style casings from the G.E.C. Blue Label range. Also, two new layer batteries which have been added to the Red Label range of The General Electric Co., Ltd.

All of these batteries are designed for the latest battery portable and combined mains-battery operated receivers referred to on page 392.

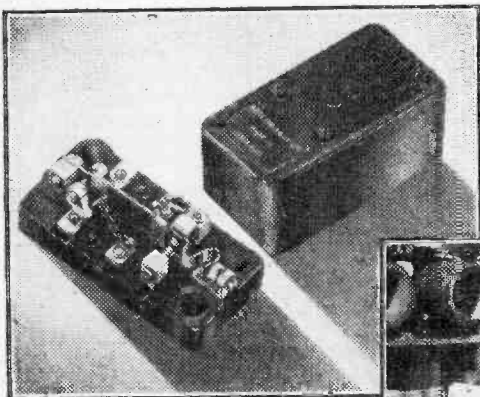

A Belling-Lee thermal delay switch.

trade-mark. An interesting feature of the items shown and which is included in the receivers is the die-cast chassis, providing mechanical rigidity and enabling more efficient screening to be carried out.

Gramophone pick-ups and motors, together with complete units, consisting of changers, three-speed players, etc., will be features by Collaro, Decca, Garrard, etc., and items are shown on pages 392 & 393.

Multicore Solders will again have a working demonstration, showing how their three-core flux is used commercially, and this year the

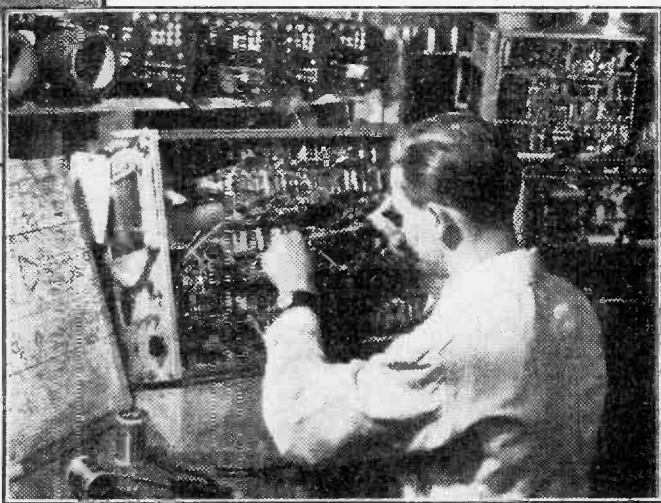

See the technicians wiring up a television camera (over 10,000 joints) on Multicore Stand No. 32.

Guide to the Exhibitors

List of Exhibitors in Alphabetical Order, with Stand Numbers



Name	Address	Stand No.	Name	Address	Stand No.
Aerialite, Ltd.	Castle Wks., Stalybridge, Cheshire	50	Kolster-Brandes, Ltd.	Footscray, Sidcup, Kent	28
Amplion (1932), Ltd.	230, Tottenham Ct. Rd., London, W.1	54	Lée Products (G.B.), Ltd.	90, Gt. Eastern St., E.C.2	77
Antiference, Ltd.	67, Bryanston St., Marble Arch, W.1	22	Linguaphone Institute, Ltd.	207/209, Regent St., W.1	96
Automatic Coil Winder & Elec. Equip. Co., Ltd.	Winder House, Douglas St., S.W.1	46	Livingston Laboratories, Ltd.	Retcar St., Dartmouth Park Hill, N.19	93
Balcombe Ltd., A. J.	52, Tabernacle St., London, E.C.2	35	McMichael Radio, Ltd.	190, Strand, W.C.2	69
Belling & Lee, Ltd.	Cambridge Arterial Rd., Enfield, Middx	25	Marconiphone Co., Ltd.	Hayes, Middx	87
Bulgin & Co., Ltd., A. F.	By-Pass Rd., Barking, Essex	1	Masteradio, Ltd.	10/20, Fitzroy Pl., N.W.1	63
Bush Radio, Ltd.	Power Rd., Chiswick, W.4	16	Mullard, Ltd.	Century Hse., Shaftesbury Ave., W.C.2	17
Chloride Batteries, Ltd.	Publicity Dept., 6/10, Whitefield St., W.1	94	Multicore Solders, Ltd.	Maylands Ave., Hemel Hempstead, Herts	32
Cole, Ltd., E. K.	Ekco Works, Southend-on-Sea, Essex	24	Murphy Radio, Ltd.	Welwyn Garden City, Herts	15
Collaro, Ltd.	Ripple Wks., By-pass Rd., Barking, Essex	91	Newnes Ltd., Geo.	Tower House, Southampton St., W.C.2	52
Co-operative Wholesale Society, Ltd.	1, Balloon St., Manchester, 4	12	Pamphonic Reproducers, Ltd.	Westmoreland Rd., Queensbury, London, N.W.9	85
Cossor, Ltd., A. C.	Cossor House, Highbury Grove, N.5	37	Peto-Scott Elec. Instruments, Ltd.	Addlestone Rd., Weybridge, Surrey	23
Decca Record Co., Ltd.	1/3, Brixton Rd., London, S.W.9	61	Philco (Overseas), Ltd.	Lion House, Richmond, Surrey	38
Dubilier Condenser Co. (1925), Ltd.	Ducon Wks., Victoria Rd., North Acton, W.3	79	Philips Electrical, Ltd.	Century Hse., Shaftesbury Ave., W.C.2	59 & 60
Dynatron Radio, Ltd.	Perfecta Wks., Ray Lea Rd., Maidenhead, Berks	40	Pilot Radio, Ltd.	31/37, Park Royal Rd., N.W.10	58
Econasign Co., Ltd.	92, Victoria St., London, S.W.1	21	Plessey Co., Ltd.	Vicarage Lane, Ifford, Essex	80
Edison Swan Elec. Co., Ltd.	155, Charing Cross Rd., W.C.2	62	Portogram Radio Elec. Industries, Ltd.	"Preil Works," St. Rule St., S.W.8	20
E.M.I. Sales & Service, Ltd.	Hayes, Middx	68	" PRACTICAL WIRELESS " & " PRACTICAL TELEVISION "		52
English Elec. Co., Ltd.	Queens House, Kingsway, W.C.2	67	Pye, Ltd.	Radio Works, Cambridge	36 & 84
Ever Ready Co. (G.B.), Ltd.	Hercules Place, Holloway, N.7	57	Radio Gramophone Dev. Co., Ltd.	Pale Meadow Print Works, Bridgnorth, Shropshire	29
Felgate Radio, Ltd.	6, Studland St., London, W.6	7	Roberts' Radio Co., Ltd.	Creek Rd., East Molesey, Surrey	39
Ferguson Radio Corporation, Ltd.	105, Judd St., London, W.C.1	88	Rola Celestion Ltd.	Ferry Wks., Summer Rd., Thames Ditton, Surrey	73
Ferranti, Ltd.	Hollinwood, Lincs	14	Regentone Products, Ltd.	Eastern Avenue, Romford, Essex	13
Garrard Eng. & Mfg. Co., Ltd.	Newcastle St., Swindon, Wilts	92	Scophony Baird, Ltd.	Lancelot Rd., Wembley, Middx	33
General Elec. Co., Ltd.	Magnet House, Kingsway, W.C.2	26 & 78	Sculptured Sound-Sali, Ltd.	79a, St. Leonard's Rd., Windsor, Berks	121
Goodmans Industries, Ltd.	Lancelot Rd., Wembley, Middx	41	Selmer & Co., Ltd., Henri	114/116, Charing Cross Rd., W.C.2	10
Gramophone Co., Ltd.	Head Office, Hayes, Middx	89	Simon Sound Service, Ltd.	48, George St., London, W.1	47
Hunt (Capacitors), Ltd., A. H.	Bendon Valley, Garratt Lane, S.W.18	56	Sobell Industries, Ltd.	Langley Park, nr. Slough, Bucks	34
Imhof, Ltd., Alfred	112, New Oxford St., W.C.1	19	Standard Telephone & Cables, Ltd. (BRIMAR)	Footscray, Sidcup, Kent	6
Invicta Radio, Ltd.	Parkhurst Rd., Holloway, N.7	71			
J.B. Mfg. Co. (Cabinets), Ltd.	86, Palmerston Rd., Walthamstow, E.17	9			

Name	Address	Stand No.	Name	Address	Stand No.
Standard Telephone & Cables, Ltd. (SenTerCel)	Connaught House, Aldwych, W.C.2	55	Telequipment Electronic, Ltd.	73a, Beresford Rd., Hornsey, N.8	83
Stella Radio & T/V Co., Ltd.	Oxford Hse., 9/15, Oxford St., W.1	27	Telerection, Ltd.	Antenna Wks., St. Pauls, Cheltenham, Glos	11
Stratton & Co., Ltd.	Eddystone Wks., Alvechurch Rd., West Heath, Birmingham, 31	124	Ultra Electric, Ltd.	Western Ave., Acton, W.3	70
Skarsten Mfg. Co., Ltd.	21, Hyde Way, Welwyn Garden City, Herts	48	Valradio, Ltd.	New Chapel Rd., Feltham, Middx	122
Taylor Elec. Inst., Ltd.	419, Montrose Ave., Slough, Bucks	53	Vidor, Ltd.	West Street, Erith, Kent	90
Telegraph Condenser Co., Ltd.	North Acton, W.3	72	Westinghouse Brake & Signal Co., Ltd.	82, York Way, King's Cross, N.1	49
Telegraph Con. & Maintenance Co., Ltd.	Telcon Wks., Greenwich, S.E.10	42	Whiteley Elec. Radio Co., Ltd.	Victoria St., Mansfield, Notts	95
			Wolsey Television, Ltd.	75, Gresham Rd., Brixton, S.W.9	76

Radio Technicians May Get Deferment

DETAILS OF RECENT CORRESPONDENCE AND AN OFFICIAL DESCRIPTION OF A "RADIO TECHNICIAN"

TO increase the number of technicians available in the radio industry, the Radio Industry Council, in agreement with the Ministry of Labour and National Service, is introducing a scheme of training for radio technical and laboratory assistants which may qualify them for deferment of military service. Trainees will register with the R.I.C. at the age of 16 or up to 17 and will be issued with a nationally recognised certificate on completion of training at the age of 21. Trainees will apply for deferment of military service in the normal way, with R.I.C. support. In a letter to member-firms the Secretary of the R.I.C. states:

"Not only will the long-term effect of the R.I.C. scheme be beneficial to the industry, but, in the short-term, the fact that the scheme has the approval of the Ministry of Labour means that trainees under it will be eligible for deferment from military service, thus maintaining the members already in training."

In a memorandum to its officers throughout the country the Ministry of Labour states that:

"Trainees are to be given progressive training through workshops, followed by a period in test departments and/or laboratories. The trainee should not normally be employed on lengthy repetition work except where such work is progressive and only as a stage in the training. The final year should be spent in the laboratories or test-room or on test-equipment maintenance or prototype construction; all work being arranged in stages so as to provide an orderly course of training to the technician level as defined."

"Trainees are to be released from one day or two half-days per week for training in (1) A National Certificate Course in Electrical Engineering, (2) An Internal Grouped Course of the City and Guilds of London Institute in Telecommunications Engineering, or (3) Such other course for the training of radio technicians as may be later determined by the Technical Training Committee of the Radio Industry Council in conjunction with the Ministry of Education."

The scheme, which has been approved by the four constituent associations of the R.I.C., lays down

only the broad lines on which training should progress and does not supplant any training scheme operated by individual companies and recognised by local offices of the Ministry of Labour, the intention being to provide a national scheme embracing existing ones.

The Ministry of Labour defines a radio technician thus:

"A radio technician is a person who carries out in a responsible manner approved techniques which are either common knowledge amongst those who are technically expert in his branch of industry or specially prescribed by professional radio engineers. These techniques are not those of the craftsman, though they may involve manual skill; in many cases they include the skilled use of delicate and complicated instruments and may also require the intelligent and accurate use of approved methods of calculation. They involve practical experience of some limited branch of radio-engineering combined with the ability to complete the details of a project using well-established practice."

"To become a radio technician a person must have received a technical education up to a standard at least, and preferably beyond, that of the Ordinary National Certificate in Electrical Engineering, and in addition must have had training and experience in the particular sphere of radio-engineering in which he is to work."

Just Published

8th (Fully Revised) Edition of the
PRACTICAL MOTORIST'S ENCYCLOPEDIA
By F. J. CAMM

With full section on Car Radio

400 pages, 493 Illustrations

17/6 or 18/- by post from:

**GEORGE NEWNES LTD., Tower House,
Southampton Street, Strand, W.C.2**

A Bench Power Pack

A STABILISED SUPPLY FOR THE WORKSHOP

By R. Hindle

IN the February, 1952, issue steps taken to prepare for a season's work were described and a simple method of condenser testing was explained. This requires a D.C. source, which could be the H.T. supply of an ordinary receiver. There are many purposes, however, for which a power supply is required for testing and for supplying items of test gear, and it is soon realised that a suitable supply should be made permanently available on the work-bench, specially designed for the purpose, sufficiently versatile and providing the necessary facilities for any reasonable requirement.

The specification of such a pack should cover the following factors :

1. *Voltage.* A nominally 350-volt supply is cheaply provided by means of standard components and probably represents the minimum for the purpose. A higher voltage is occasionally an advantage, but unfortunately the cost of additional volts (other factors being equal) rises steeply. It is desirable also to arrange for lower voltage outputs either by adjustment to the main output or by the provision of alternative outputs.

2. *Current.* This will vary considerably for different purposes from zero upwards. The maximum that can be provided by standard components of reasonable price is 150 mA. and this will probably be found adequate.

3. *Regulation.* An ordinary power pack, even assuming an unvarying input mains voltage, will vary considerably in D.C. voltage output depending on the current drawn by the load applied. Using a 350-0-350-volt mains transformer feeding a standard rectifier circuit the output will rise to nearly 500 volts when no current is being drawn from it, falling to 350 volts on normal load. The smoothing condensers form part of the load and if electrolytics are used the leakage current is appreciable. The change in voltage with varying load is called the regulation of the supply, which is said to be good when the voltage change for a given change in current is low. The regulation is conveniently measured by calculating the equivalent resistance represented by the change in output voltage caused by a change in load current and the aim is to design for a minimum equivalent resistance. For instance, a change of 100 volts in output for a change of 100 mA. in load current is (by Ohms Law) equivalent to a resistance of 1,000 Ω , but if the output voltage can be regulated so that for the same range of current change the output voltage change is only 1 volt the equivalent resistance is only 10 Ω .

To combine in a single output all these requirements, i.e., a variable voltage with a high maximum, providing a large current and giving an equivalent resistance in the region of unity, is likely to prove expensive and complicated, but by providing different outputs for different purposes an almost equally useful pack can

be produced at a reasonable cost. In practice it is unlikely that the full output voltage or the full current output will be required for use when exceptional regulation is called for and so the arrangement is to feed out the unregulated full voltage capable of giving the maximum current and to provide an alternative regulated source giving somewhat lower power.

Adjustment of Voltage

It is not easy to provide facilities for continuously variable voltage output from an unregulated source in a predictable form to operate over a wide range of current outputs and in practice it is easier to arrange for voltage dropping in the individual pieces of equipment to be connected to the pack. The regulated supply serves the purpose, however, of a voltage tap in cases where regulation is not required, and consequently it is as well to design the regulated output to supply a reasonably high current. The regulated output can be made continuously variable over a limited range.

Basic Power Circuit

The design of the basic power supply circuit follows conventional lines. A full-wave rectifier is used in preference to a half-wave circuit, as is customary when a mains transformer is used, because it is then easy to provide the required centre-tapped alternating voltage source. The advantages of the full-wave circuit are :

1. The peak current flow through the rectifier for a given load current is less and consequently when the load is drawing up to maximum current rating there is less strain on the rectifier cathode.

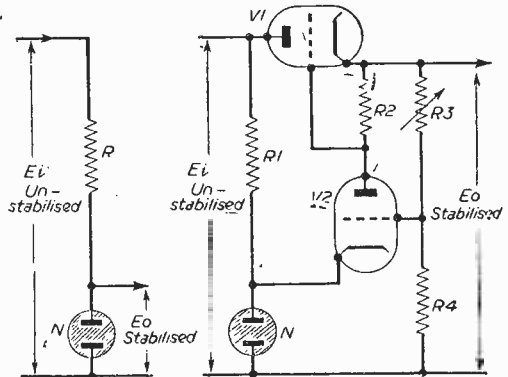

Fig. 1 (left).—Parallel neon stabiliser, and Fig. 2 (right).—Series valve stabiliser.

2. The peak current referred to in 1 is determined by the size of the reservoir condenser as well as by the load. It is possible, therefore, to use a larger reservoir condenser with full-wave than with half-wave rectification without fear of damaging the rectifier.

3. Smoothing is more effective with full-wave rectification because the fundamental hum frequency is 100 c/s whereas with half-wave rectification it is 50 c/s (assuming 50 cycle mains).

Of the alternative reservoir condenser arrangements the choke input circuit (i.e., where the reservoir condenser follows the first smoothing choke) gives better regulation but it also reduces the output voltage and as more effective regulation (or stabilisation, as it is alternatively called) is planned the more conventional condenser input circuit is adopted.

Regulation Design

Two methods of regulation are available. The first is to introduce a variable current device in parallel with the load which will draw more current from the supply as the load takes less, so counteracting the tendency for the supply voltage to rise. Similarly, if the supply voltage tends to rise because of an increase in mains voltage the device draws more current, holding down the voltage supplied to the load. Thus the regulating device takes care of both load fluctuations and mains fluctuations.

The second method is to put in series with the load a device the resistance of which varies inversely as the current flowing through it. When the load current increases the unregulated supply voltage tends to decrease but the resistance of the regulating device decreases and, therefore, the voltage dropped across it decreases, tending to hold constant the voltage applied to the load. On the face of it this method would seem to be useless in cases of mains voltage fluctuations because an increase in mains causes an increase in rectified supply voltage which would generally cause an increase in current drawn which, by the above argument, would cause a decrease in resistance of the regulating device, so accentuating instead of counteracting the voltage increase presented to the load. This is not the case, however, because though the regulation is due to a change in voltage drop caused by varying the resistance, the degree of that change is controlled, not by the current flowing, but, as will be seen later, by feeding back the voltage change as presented by the load, much in the same way as the more familiar A.V.C. operates.

The simplest example of the first type of regulating device, or stabiliser, is the neon tube which tends to keep the voltage across it stable by drawing more current as the voltage increases and vice versa. The simple circuit is given in Fig. 1. An increase in load current increases the voltage drop across R, decreasing the voltage presented to the load and to the neon N. N now draws less current, however, and as its current also flows through R the total current through R tends to be stable and consequently the voltage across it tends to stabilise and the voltage change across the neon and the load is largely counteracted.

This method is reasonably effective but it is not good enough for many purposes. Its equivalent resistance is about 300Ω , a long way from the 1Ω stipulated

in the specification at the beginning of this article. The current range over which it can work is also limited. The stabilised output voltage of a neon tube is fixed by the voltage at which the tube burns after it has struck (i.e., when the gas content glows), and cannot be adjusted, but stabilisation at multiples of the burning voltage can be achieved by using neons in series and connecting a high resistance across each neon to ensure voltage distribution. The Stabilivolt is, in fact, a number of neon cells in one envelope, giving regulated outputs in steps of 70 volts, the burning voltage of the individual cells.

Hard valve circuits of the parallel type are practicable but for normal use the second (series) type is generally preferable when more complicated regulating circuits are to be used. A valve takes the place of the series variable resistance element, its resistance (r_g), which varies with its grid voltage (e_g), being controlled by a second valve which serves to amplify the fluctuations in the stabilised output, feeding them back negatively to the controlling valve.

Circuit

The basic circuit is given in Fig. 2. It will be seen that the grid bias between grid and cathode of V1 is provided by the voltage across the load resistance (R2) of V2. This voltage is determined by the anode current of V2, which flows through R2 and this current in turn is determined by the grid bias which, it should be remembered, is not the voltage of the grid with respect to earth but the difference in voltage between the grid and the cathode.

R1 and N form a stabiliser of the simple type previously discussed. V2 draws its current through N, interposed between its cathode and earth or H.T. negative. The cathode is thus held steady at the burning voltage of N. A proportion of the output voltage (E_o) selected by the potentiometer formed by R3, R4, is applied to the grid of V2. The difference between this grid potential and the neon burning voltage is the effective bias to V2 which determines the valve current and, therefore, the voltage across R2 which is the bias to V1. Any variation in E_o is applied in part to the grid of V2, changing the bias of V1 and so changing the effective resistance of V1 to compensate for the output voltage change. Suppose the voltage output tends to increase. Then the grid of V2 goes more positive (i.e., the effective grid bias is less negative). V2 now draws more current and there is a greater voltage drop across R2. This is the bias to V1, which is thus increased, increasing the effective resistance of V1, increasing the voltage drop across V1 and so counteracting to a large degree the increase in E_o that would otherwise take place.

If V2 is arranged to give a high degree of amplification the voltage at the grid of the valve (i.e., across R4), will need to vary only slightly to run V1 through a wide degree of control and so the voltage can be considered to be comparatively stable and about equal to the burning voltage of N. The current through R4 to sustain this voltage is drawn through R3 from the stabilised voltage source. The voltage output can thus be said to be determined by the ratio of R3 to R4 because the current producing approximately the burning voltage of N across R4 is the only current through R3 and by Ohms Law the voltage across R3 is in proportion to the resistance of R3.

(To be continued)

On your Wavelength

by THERMION

On Choosing a Receiver

PRIOR to and during every Radio Show I am asked to give advice on the choice of a receiver. I have some decided views on the matter. I always advise those who consult me to prepare a short list of makes by a process of elimination which I will now describe.

The first consideration is service after sales. A receiver may look most attractive and its price may appeal, but if it is backed by unreasonable service or by service conditions which convert a comparatively cheap receiver into a dear one after a year or so, don't buy it. If there is not a dealer in your district, for example, handling that particular make, you are going to be put to some expense in collection and delivery fees when the set goes wrong. I do not say that receivers made by small firms are unsatisfactory; what I do say is, that in some cases their service is unsatisfactory and their charges exorbitant.

The next point to ascertain is whether the manufacturers supply with the receiver reasonable technical data to enable the skilled owner to carry out the simpler adjustments and repairs on his own. For this purpose he will need a circuit diagram and a list of component values and their makes. Typical voltage and current readings should also be given. This is the first snag the would-be purchaser will come up against. There are some firms (in the majority I am afraid) who do not supply such data, except to their recognised agents. They want to force the purchaser into the agents' hands, and, unfortunately, the reputation of some dealers in the matter of excessive charges is too well known to need further stressing by me. I have never been able to understand this stupid attitude on the part of some manufacturers in refusing to disclose values and circuitry.

Another point concerning servicing is this: before buying a receiver ascertain whether it is the policy of the maker to ask for an examination fee. This can amount to as much as 30s., even more. Such a charge, in my view, is unjustifiable, and I would not, myself, buy a receiver from such a manufacturer. This examination fee has to be paid, in some cases, *whether the repairs are finally put in hand or not*. The unsuspecting purchaser writes to the maker complaining of some defect and the manufacturer then collects the receiver. Within a week or so (!) the owner will receive an estimate for repairs to which has been added the examination fee. I do not advise the purchase of a receiver where the policy of the manufacturer is to dip into your pocket on service charges throughout the life of the receiver. I take it that the would-be purchaser has made up his mind whether he requires a table model or a console, whether he requires a radiogram, all-wave or two-wave coverage, quality reproduction or an "ether roamer" set. The size of the room in which the receiver is to be installed and the nature of its furnishings, particularly the timber employed, will, of course, decide to some extent the cabinet style. It is a simple matter with these facts in mind to go

through makers' lists and to prepare a short list. From that point, investigate the various points I have enumerated above, when you will find that the short list becomes even shorter! Manufacturers should understand that we are not still in the twenties. Most people to-day have a reasonable knowledge of radio. It would seem the policy of some firms to manufacture sets and sell them at a small profit or at cost and rely upon service charges to make their profits!

There is not a receiver on the market, the performance of which cannot be equalled or excelled by a well-designed, home-built receiver. The most recent design published by this journal—the "P.W." Three-speed Autogram—is a good example. I listened to a demonstration of this and I can say with certitude that there is not a receiver on the market of equivalent quality. Certainly, by building a set yourself, you save that monstrous deodand, 66½ per cent. purchase tax, which the merciless State imposes on all commercial radio receivers. It is possible, too, to buy very cheap components to-day, thus effecting a further saving.

The "P.W." sponsored designs are backed by a better technical advice service than that of many manufacturers. It is free, too, and prompt. The service this journal gives to builders of its receivers is excellent and highly valued—even by dealers, many of whom avail themselves of it.

Whilst I am dealing with the choice of a receiver it is interesting to observe from recently published statistics, that the average number of sets sold per shop continued to show a decline. The restriction on hire purchase imposed in the Budget probably has something to do with this, although I observe that the profits of one or two manufacturers are up.

The BBC Governors—Selection Plan Dropped

I AM glad that the Government has dropped its plan to set up an independent committee responsible for the selection of BBC governors. I would like to see all of the governors sacked as well, for I do not like the system. The BBC is not a university and it should be run on straight-forward commercial lines with a board of directors, a chairman, each of whom is working full time. I have not liked in the past the choice of governors.

Shape of Things to Come

THE recently announced formation of a company to develop equipment for sponsored broadcasting is a straw indicative of the changing pattern of broadcasting in this country. The company intends to provide the type of service approved by the Government's White Paper on broadcasting and which Parliament has endorsed. The first programme will be awaited by your humble scribe with more than ordinary interest, and I shall await with even greater relish the comments of those radio critics, so-called, who are under the mistaken impression that criticism automatically implies evisceration of the person or the subject criticised. At best they praise with faint damns.

the decrease of the voltage drop across R_1 (see Fig. 1), R_1 being a resistor externally connected between the anode and the target.

The fluorescence has a somewhat fan-like movement and it is therefore entirely dependent upon the biasing of the control grid.

In actual circuit use the controlling voltage is sometimes taken from the A.V.C. circuit (Fig. 1) and thus an indication of resonance is given when the unlit portion of the target is at minimum. Alternatively, some types are recommended to have their controlling voltage taken from a detector circuit and not the A.V.C. diode circuit. This enables visual tuning to be obtained below what is termed a delay point (Fig. 2).

For Measuring Equipment

As a point of interest, the majority of the surplus indicators have one ray control electrode and the triode unit in one envelope, but one type, namely

the CV847, has two ray controlling electrodes and requires a separate triode valve to act as the amplifier. However, these two controlling electrodes can be strapped together in parallel and used as one element (Fig. 3) and with a separate triode they can be used in a conventional circuit.

The types available on the surplus market are listed in Table One which also includes their electrical characteristics; this table should, however, prove useful to the experimenting amateur as well as the constructor. Furthermore, these valves lend themselves admirably to the amateur who likes to construct measuring equipment. One such piece that can be constructed is that of a valve voltmeter, wherein the indicator replaces the conventional meter.

For measuring equipment it is advisable to adopt the most sensitive types for reasons of accuracy. In conclusion, one must not forget that the cost of such valves against that of a good quality microammeter is very small.

VHF Broadcasting in the U.S.A.

A REPORT ISSUED BY MESSRS. PYE, LTD.

AS stated in our Editorial page last month, a report has been circularised in this country covering the position of VHF in the U.S.A. and as this is of great importance in view of the findings of the Beveridge Committee, we feel that readers would like to have the opportunity of reading the report, a copy of which is given below:

"It is paradoxical that while Britain is apparently about to embark on VHF broadcasting, in America where FM VHF broadcasting has been in existence for fifteen years many people are wondering whether it can survive much longer. In the belief that the facts about U.S. FM broadcasting are insufficiently well known in this country we have compiled the following report. It is based mainly upon a survey carried out by two of our executives who have just returned from a two months' visit to the U.S.

The facts and figures given in the report have been obtained from four sources:—

- (a) The FCC personnel and records.
- (b) The American Radio and Television Manufacturers' Association.
- (c) The American journal 'Broadcasting.'
- (d) Interviews with manufacturers and station operators in many parts of the U.S.

Receiver Production

In 1952, 15 years after the establishment of the first FM stations, only 5 per cent. of all sound radios and only 2 per cent. of all TV sets currently manufactured incorporate FM Sound Broadcasting.

An indication of its importance in the eyes of the American public is obtained from the fact that three times as many 'clock' radios and seven times as many car radios are sold as are FM models.

The largest radio receiver manufacturer stated that about 5 per cent. of his sets had an FM range and the biggest and most 'loyal' FM manufacturer stated that about 12 per cent. of his output

had FM. Many manufacturers have dropped FM altogether.

Receiver Price

AM table radios retail at from 12 to 40 dollars. A typical table model sells at about 30 dollars. A similar model, including an FM range, sells at about 60 dollars. The cheapest FM model sells at 55 dollars, and the FM table model may be priced as high as 90 dollars.

If similar circuits were adopted by British manufacturers the typical table model now costing £15 would cost £30 with FM, plus tax in both cases.

The cost of receivers has undoubtedly been one important factor in inhibiting the sales of FM radio in the U.S., but in spite of this, past efforts to produce really cheap FM have failed and been dropped.

The super-regenerative receivers and convertors now being tried out in Germany have disappeared from the market entirely. Those American manufacturers who still market FM have come to the conclusion that an FM receiver must have high sensitivity, good limiting, low drift and low distortion even if these features make the resulting receiver expensive.

On the retail side we could find little enthusiasm for FM, most models being sold at a discount. At Macey's radio department we counted 130 radios on show. Only five had FM.

There is no such thing as an FM portable or an FM car radio. This is presumably because the cost would far outweigh the advantages, if any, of FM in these spheres.

Station Operation

The position here is equally gloomy. There are some 600 FM stations licensed compared with 2,700 AM. The number has dwindled from 800 at the peak period and it is expected to continue to decline. Many existing FM operators have submitted appli-

cations to FCC asking to be allowed to reduce their hours of operation.

Of the 600 stations in existence only 65 represent independent operations. The others are affiliated to AM stations and merely duplicate the AM programme. Of the independent stations only six claim to have shown a profit in 1951. The majority of the others lose money heavily. Twenty-one such stations were closed down in the year 1950-51 alone.

No separate figures are available for the affiliated stations, but most of these seem to represent a 'holding down the channel' operation. The comment of the station manager of WHAM Rochester was typical. He stated that if his AM outlet broke down his telephone switchboard would be inundated with complaints within a half-minute. The FM outlet conveying the same programme could fail for half an hour and no one seemed to mind, and no calls would be received.

The position of FM has not been greatly influenced, as one might think, by television. This is shown by the AM station revenue figures. In TV-developed areas AM revenue was down by only two per cent. in 1951. In non-TV areas AM revenue was up by 10 per cent. It is interesting to note that TV is so far showing little sign of ousting AM sound radio in the U.S. It is merely changing its character and the listening habits of the public.

Public Reaction

No official estimates were available of the number of listeners using FM but it is probably less than one per cent. The average listener does not have it on his set. Of those who do, many just do not use the FM band.

FM does make a limited appeal to certain minorities such as:—

- (a) High quality reproduction enthusiasts.
- (b) Rural listeners in those areas where night-time reception of AM is bad.
- (c) The smalltown local station listener whose daytime only AM station closes down at night.
- (d) Foreign language and educational broadcasts to minority groups in the metropolitan areas.
- (e) Specialised broadcasting such as broadcasting background music to restaurants.

None of these functions constitutes a primary public service and few have any commercial attraction. FM in the U.S. is at best a gap-filler for the AM services. It has met with no success when trying merely to do what the AM stations do already, but to do it a little better. Such success as it has had has been in tackling those specialised fields which the AM stations neglect. It is largely in the hope that these special functions may grow to flourish that FM is warding off the threat of extinction.

Conclusion

One is led to conclude that in the U.S. at least, FM receivers are much too expensive in relation to what they offer the public in terms of improved reception or alternative programmes. In the eyes of the public the FM band is probably worth about as much as the inclusion of a short wave band is to a British listener.

On the other hand all attempts to meet this low price bracket have been abandoned by the American manufacturers. One has the impression that their

problem would have been substantially easier and the position healthier if the modulation choice had been AM, but the overall impression is that any form of VHF sound broadcasting has a very difficult furrow to plough.

So far as Britain is concerned there is reason to fear that VHF broadcasting may suffer a similar or a worse fate. If we stumble into it without benefiting from the American experience it probably will.

It is certainly incumbent upon those who promote it to advance logical reasons why it may be expected to fare better.

J. R. BRINKLEY, J. O. STANLEY,
Pye, Ltd., Radio Works, Cambridge.
3rd June, 1952."

British L.P. Discs. for U.S.A.

FURTHERING the close co-operation which has existed for so many years between R. C. A. Victor (U.S.A.) and the Gramophone Company Ltd. (England), the companies have made a joint announcement in America that a new series of English records is to be launched on the United States market.

This distinctive new series will be composed entirely of H.M.V. Long Play 33½ r.p.m. records and the new 45 r.p.m. 7in. microgroove records. The series will present those world-renowned artistes and conductors who are under contract to the Gramophone Co. Ltd.

The rapidly expanding market for Long Play records and for the 45 r.p.m. microgroove records in America gives every hope that the introduction of this new series of British recordings will prove a most valuable contribution to the dollar export market.

Behind this interesting announcement lies the fact that there has always been in America a considerable section of the music-loving public who like to have British recordings and also, of course, the fact that many artistes and conductors of world repute are under contract to the Gramophone Co. Ltd.

All of the recordings involved have been made in England or European countries on British equipment, which ensures artistic performance and recording quality without superior in the world.

As a gesture which proved of especial interest to Americans, the Gramophone Co. Ltd. flew the original "His Master's Voice" trademark painting to New York for the launching of these important new records. It was exhibited at the Press conference held in New York when the introduction of the new series was announced.

This is the first time that this world-renowned picture has been to America and the interest on its arrival was quite remarkable. Arrangements were quickly put in hand for television and radio programmes to be broadcast featuring the romantic story behind this painting.

J. David Bicknell, "His Master's Voice" artistes manager, who accompanied the picture on this flight to New York, recorded a half-hour interview for subsequent transmission over an important American radio network and the picture was in great demand by American Press photographers.

Painted by Francis Barraud before the turn of the century, this picture has left the company's board room only once before in 50 years. This was on the occasion of its exhibition at the Royal Easter Show in Sydney, Australia, in 1950.



MODEL 77A—20,000 o.p.v. An entirely new instrument incorporating the latest improvements in manufacturing technique. Refinements include shockproof moulded case, clear and easy to read scales, leather carrying handle, and many other features.

OVERLOAD PROTECTION. Meter movement has instantaneous overload protection, effective on all ranges.

BUZZER. A Buzzer is fitted internally for quick continuity testing.

METER. Precision engineered moving coil, fitted with 5" scale and knife edge pointer.

SWITCHING. One switch selects both circuit and range. Heavily silver plated beryllium copper switch contacts ensure low loss and trouble-free operation. Large 2" milled knob for easy handling

SENSITIVITY. 20,000 ohms per volt D.C., 5,000 ohms per volt A.C.

RANGES :—

VOLTS D.C. 0-7.5-30-75-300-750-3,000.

VOLTS A.C. 0-7.5-30-75-300-750.

MILLIAMPS D.C. 0-.15-1.5-15-150-1,500.

AMPERES D.C. 0-15

RESISTANCE. 10 ohms-5 megohms in two ranges with self-contained battery.

OUTPUT. As for A.C. volt ranges except 3,000 V., via a condenser.



Limited supplies from stock now available for the home market.

AVAILABLE ON HIRE PURCHASE TERMS AT LIST PRICE.

List Price **£15 - 0 - 0** or **£2 - 5 - 0** Deposit and 10 Monthly Payments of **£1 - 8 - 8.**

Please write for illustrated leaflet featuring our new range of radio and television test gear.

TAYLOR ELECTRICAL INSTRUMENTS LTD.

MONTROSE AVENUE, SLOUGH, BUCKS

Telephone : SLOUGH 21381

G.E.C. flat screen 12"

Types 6705A and 6706A cathode-ray tubes have now been introduced and replace the types 6703A and 6704A respectively for all equipment purposes. These tubes have a practically flat screen and a design-centre maximum anode voltage of 10 kV.

In all other respects, these latest types are similar to those they replace: aluminised screen for longer life and outstanding brilliance; external conductive coating, which, in conjunction with the internal coating, can be used as the E.H.T. reservoir capacitor; and the standard international octal base.

Heater ratings:

6705A. 6.3 volts 0.5 amps. approx.

6706A. 0.3 amps. 10.5 volts approx.

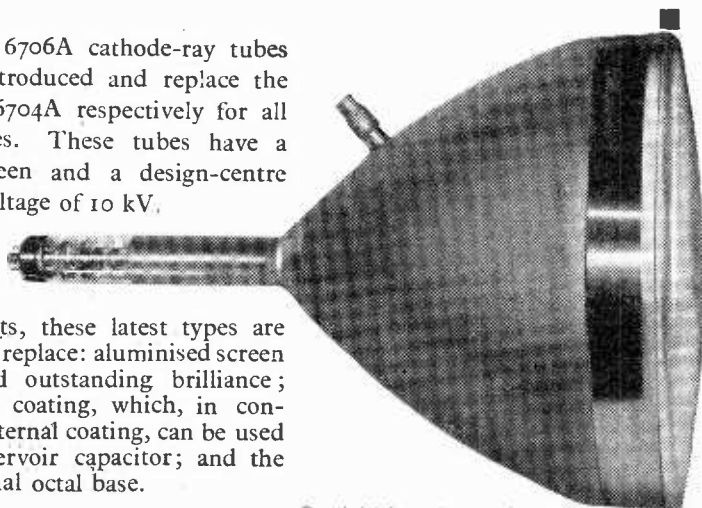

Cathode-Ray Tubes

Detailed information on these tubes, and Osram valves suitable for television, may be obtained from:

OSRAM VALVE & ELECTRONICS DEPT.

THE GENERAL ELECTRIC CO. LTD., MAGNET HOUSE, KINGSWAY, W.C.2.

CONSTRUCTOR'S POLISHED CABINET. Size 10 x 6 1/2 x 5 in. approx. supplied in flatbed form, grooved and ready to glue together. Complete with plastic front, 5 valve chassis, cadmium plated, size 8 1/4 x 4 1/2 in. tuning scale, knob and back. Illustration shows it would look when assembled. Two bottom knobs not supplied. 10/-, plus 1/6 post and packing.



Twin-gang and Pair of T.R.F. Coils with circuit to suit above 8/6.

Wave-change Switches, 6-pole 3-way, 2/-; 3-pole 2-way, 1/2; 4-pole 3-way 1/8; 5-pole 3-way 1/8; P. & P. 3c. each. Valveholders, Paxolin International Octal, 4d. each. Moulded international Octal, 7d. each. EF50 ceramic, 7d. each. Moulded BTG slightly soiled, 6d. each. Trimmers, 5-40 pf. 5d.; 10-110, 10-250, 10-450 pf., 10d. Twin-gang .0005 Tuning Condensers, 5/-, With trimmers, 7/6. Midget .00037 dust cover and trimmers, 8/6.

P. M. SPEAKERS with less trans. trans.

2 1/2 in.	15/6	11/6
3 in.	15/-	11/6
5 in.	14/6	11/6
6 1/2 in.	17/-	13/6
8 in.	16/-	13/6

Post and packing on each of the above, 1/- extra.

PERSONAL PORTABLE CABINET in cream-coloured plastic; size 7 x 4 1/2 x 3 in. Complete 4-valve chassis. Scale and 3 knobs. Takes miniature 90 v. and 7 1/2 v. batteries, 9/-, 2 1/2 in. P.M. Speaker to fit above, 13/6. Miniature output transformer, 5/-. Miniature wave-change switch 1/6. Miniature 1-pole 4-way used as Volume and Off, 1/6. 4 BTG valveholders, 2/-. Midget twin-gang (in. dia., tin. long and pair medium and long-wave TRF coils tin. long x tin. wide; complete with 4-valve all-dry mains and battery circuit, 8/6. Condenser Kit, comprising 11 miniature condensers, 3/6. Resistor Kit, comprising 16 miniature resistors, 4/-. The above receiver (less valves and batteries) could be built for approximately 49/-.

Point to Point Wiring Diagram, 1/-. Four valves to suit above, £2, post paid.

Terms of business:—Cash with order. Dispatch of goods within three days from receipt or order. Where post and packing charge is not stated, please add 1/- up to 10/-, 1/6 up to £1 and 2/- up to £2. All enquiries and Lists, stamped, addressed and enclosed.

D. COHEN TELEVISION COMPONENTS 23, HIGH STREET, ACTON, W.3. (Opposite Granada Cinema)

Hours of Business: Saturdays 9-6 p.m. Wednesdays 9-1 p.m. Other days 9-4.30 p.m.

Constructor's Parcel, comprising chassis 8 in. x 4 in. x 1 1/2 in. with speaker and valveholder cut-outs, 5in. P.M. speaker with transformer, twin gang with trimmers, pair T.R.F. coils long and medium, iron cored, four valveholders, 20 K. volume control and wave-change switch. 21/-.

6 Iron-cored Coils on Alladin formers, 13-50, 188-550, and 950-2000 meters. 1 F. 465 Kc. tuning condenser .0005, 8/6. Mains or Battery Superhet Portable Coils. Comprising medium-wave frame aerial and long-wave loading coil, used as aerial coils. Midget iron-cored screened L/M coils, complete with circuit I.F. frequency 465 Kc., 9/6.

465 Kc. Midget I.F.s. Q.120, size 1 1/2 in. long, 1 in. wide, 1 in. deep, by very famous manufacturer. Pre-aligned adjustable iron-dust cores. Per pair, 12/6. Coils and I.F.s. £1, post paid.

Midget Bakelite Cabinet, 7 x 5 1/2 x 5 in. with 5 valve chassis, medium and long wave scale and back (takes standard twin-gang and 3 1/2" speaker), 15/-, plus 1/6 post and packing.

Output Transformers. Standard type, 5,000-ohms Imp. 2-ohms speech coil, 4/9; Push-Pull 6 v. 6 matching 10-watt 2-ohms speech coil, 6/9. Miniature type 42-1, 3/3.

MAINS TRANSFORMERS

These transformers are all famous radio manufacturers' surplus and are fully interleaved, impregnated and guaranteed.

Primary, 200-250 v. P. & P. on each, 1/6 extra.

250-0-250 100 mA., 4 v. 4 amp., 4 v. 2 amp., upright or drop-through. 16/-.

300-0-300, 100 mA., 6 v. 3 amp., 5 v. 2 amp., 17/6.

Drop-thro', 350-0-350 v. 70 mA., 6 v. 2.5 amp., 5 v. 2 amp., 14/6.

280-0-280, semi-shrouded drop-through, 80 mA., 6 v. 3 amp., 5 v. 2 amp., 16/6.

Semi-shrouded, drop-thro', 280-0-280, 80 mA., 4 v. 6 amp., 4 v. 2 amp., 12/6.

Auto-wound, H.T. 280 v. at 360 mA., 4 v. 3 amp., 2 v. 3 amp., or 6 v. 3 amp. Separate 4 v. 3 amp. rectifier winding (upright or drop-through), 10/6.

350-0-350, 120 mA., 4 v. 4 amp., 4 v. 3 amp., drop-through, 21/-.

Auto-transformer, various combinations of voltages including 110 v. 70 watts, and 3/4 v. windings at 1 amp., 2 v. 1 amp., drop-through or upright mounting, 10/6.

250-0-250, 60 mA., 6 v. 3 amp., 12/6.

250-0-250, 80 mA., 6 v. 4 amp., 14/-.

Pri. 230 v. Sec. 200-0-200 35 mA., 6 v. 1 amp., lamp, 8/6.

Heater Transformer, Pri. 200-250 v. 6 v. 1 1/2 amp., 6/-; 2 v. 2 1/2 amp., 5/-; P. & P. each 1/-.

RADIO SUPPLY CO. 15, WELLINGTON ST., LEEDS, 1.

Post Terms C.W.O. or C.O.D. No C.O.D. under £1. Postage 1/- charged on orders up to £1; from £1 to £3 add 1/6; over £3 post free. Open to callers 9 a.m. to 5.30 p.m. Saturdays until 1 p.m.

R.S.C. MAINS TRANSFORMERS

Fully Guaranteed. Interleaved and Impregnated. Primaries 200-230-250 v. 50 c/s Screened.

TOP SHROUDED DROP THROUGH 0-9-15 v 6 a., 22/9; 0-4-9-15-24 v 3 a., 22/9; 0-9-15-30 v 3 a. 23/9

SMOOTHING CHOKES 200 ma., 3-10 h. 50 ohms 18/9
250 ma., 3 h. 100 ohms 8/9
200 ma. 5 h. 100 ohms 7/6
100 ma., 10 h. 100 ohms 7/6
60 ma., 10 h. 100 ohms 5/9
60 ma., 10 h. 350 ohms 5/6

ELIMINATOR TRANSFORMERS Primarkes 200-250 v 50 c/s., 120 v 40 ma. 7/11
120-0-120 v 30 ma., 4 v 1 a. 12/9

OUTPUT TRANSFORMERS Midget Battery, Pentode 66: 1 for 3S4, etc. 3/6
Small Pentode, 5,000 ohms to 3 ohms 3/9
Standard Pentode, 5,000 to 3 ohms 4/0
Multi ratio 40 ma., 30: 1, 45: 1, 60: 1, 90: 1 Class B Push-Pull 5/6
Push-Pull 10-12 watts 6V6 to 3 or 15 ohms 15/11
Push-Pull 10-12 watts to match 6L6, FX4, 6V6, etc. to 3-5-8 or 15 ohms 10/11
Push-Pull 15 watts to match 6L6, etc. to 3 or 15 ohms Speaker 22/9
Williamson type, exact to author's spec. 85/-

SPECIAL OFFERS. Mains Trans. 220-240 v Primary 6.3 v 1.5 a., small Ex. Gov. Block Paper 4 mid. 600 v. P.M. SPEAKERS. All 2-3 ohms, 5in. F.W. 11/9; 5in. Goodmans, 12/9; 6in. F.W. 13/11; 8in. Plessey, 14/6; 8in. Rolva, 17/6; 10in. Goodmans, 26/9

VOL. CONTROL'S. All values, long spindle, mesh switch, 26/-; with S.P. Switch, 3/11. (CHASSIS.—1 1/2 s.w.g. Undrilled Aluminium. Receiver type.—10-51-2in., 3-9; 11-6-2in., 4/3; 12-8-2in., 5-3; 11in., 7/6; 20-8-2in., 8/11; Amplifier type.—12-9-2in., 7/11; 16-8-2in., 10/11; 14-10-3in., 12/9

EX-GOVT. VALVES (NEW) 174 8/11 6V6GT 8/11 EF39 7/6
184 8/11 6X5GT 9/6 EF50 6/6
185 8/11 6X4 9/6 EF80 12/9
1R5 8/11 8D2 2/9 EF92 11/9
2C34 1/11 9D2 2/11 EF91 11/9
4D1 1/11 954 1/11 ECL80 12/9
5Y3G 9/6 12A6 7/9 KT41 13/9
5Y4G 11/6 12B6 11/6 KT61 9/6
5Z4C3 9/6 12K8GT 9/9 KT66 11/6
7E2 5/4 9/6 12R7GT 10/6 KT2 4/11
7E6 6/5 6/11 12Q7GT 10/6 MS/PEN5/6
6A5 9/11 12SH7 5/9 MHL6 9/6
6B7G 5/11 12SC7 6/11 MU14 9/6
8U7 7/6 15D2 4/6 PEN46 9/6
6K7G 6/6 25L6GT 10/6 RK34 1/11
11J1 6K7 7/6 35Z4GT 10/6 SP4 5/6
607G 9/11 31L6GT 9/9 U50 9/6
6BK7 9/11 80 10/6 QP21 6/9
6CS7 6/9 D1 1/3 VU12 2/9
6V6 6/11 EF36 6/9 Y63 10/6

SELENIUM RECTIFIERS.—Ex New Equipment. 120 v 40 ma. (small). 3/3. New 36 v 50 ma. 1ld.; 12-15 v 2 1/2 a. F.W. Bridge, 13/9; 12-15 v 4 1/2 a. F.W. Bridge, 18/9.

ELECTROLYTICS. Tubular 8 mfd. 350 v. 1/6; 8 mfd. 450 v. 1/11; Can 16 mfd. 450 v. 2/11; 8-8 mfd. 450 v. 3/11; 8-16 mfd. 450 v. 4/6; 12-12 mfd. 450 v. 6-16 mfd. 450 v. 4/6; 32 mfd. 350 v. 3/9; 32 mfd. 450 v. 4/9; 32-32 mfd. 350 v. 5/9; 32-32 mfd. 450 v. 6/9; 32-32 mfd. 350 v. 5/9; 32-32 mfd. 350 v. plus 25 mfd. 25 v. (small), 4/11.

Continued in Classified Columns.

FULL RANGE OF STANDARD COMPONENTS AVAILABLE AT KEEN PRICES. ALL GOODS GUARANTEED AND NEW UNLESS OTHERWISE STATED. QUANTITY QUOTATIONS GIVEN FOR STANDARD TYPE OR SPECIAL TRANS. S.A.E. PLEASE WITH ALL ENQUIRIES. FULL STOCK LIST, 4d. SPECIAL LIST FOR TRADE, 4d.

FILAMENT TRANSFORMERS All with 200-250 v 50 c/s primaries: 6.3 v 2 a., 7/6; 0-4-6.3 v 2 a., 7/9; 12 v 1 a., 7/11; 6.3 v 3 a., 10/11; 6.3 v 6 a., 17/9; 0-2-4-5-6-3 v 4 a., 17/9; 12 v 3 a., or 24 v 1.5 a. 17/9

CHARGER TRANSFORMERS All with 200-230-250 v 50 c/s Primaries: 0-9-15 v 1.5 a., 13/9; 0-9-15 v 3 a., 16/9

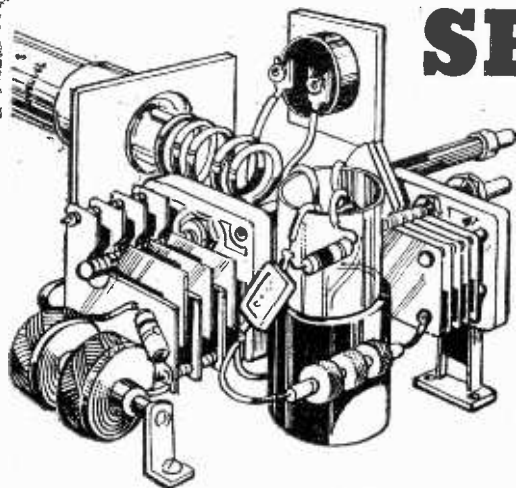

SHORT-WAVE SECTION

SHORT-WAVE LOGS AND LISTENING

By A. W. Mann

TO-DAY the short-wave bands have much to offer the active short-wave listener. Time was, however, when the frequency channels were much less congested, transmitter power relatively low, and receivers less sensitive than is the case to-day.

In spite of such handicaps there was much of interest to be heard on the broadcast, commercial and amateur bands.

Most of the broadcast stations were of an experimental nature, and were engaged in collecting data as to suitability of wavelength according to the time of day.

The coming to light of a number of old log books brings to mind much that has been heard at the writer's location and since forgotten.

The American pioneer KDKA, for example, transmitted on a wavelength of 62.5 metres, while 2XAF was on 32.77 metres, 2XL 90 metres and WRB on 70.74 metres. In the writer's opinion the programme material of those days was superior in many ways to some present-day broadcasts from the U.S.A.

There were, of course, a considerable number of European stations on the air, and anything heard outside of Europe was regarded as DX.

Africa

African broadcasters on the air now are in some instances using comparatively high power, and are thus more or less consistently received throughout the world. During the period under review, however, there was but one low-power transmitter. This was the first colonial short-wave station 7LO Nairobi, Kenya Colony, transmitting on a wavelength of 100 metres.

Until the wavelength was changed to 31 metres all my attempts to receive those transmissions failed. We did eventually hear an outside broadcast from a lions' drinking place.

There are now several stations transmitting programmes from various parts of the African continent, but QRM in the case of Nairobi and other low-power ones makes reception difficult.

The reception of these stations is a good test by the way for those interested in directional aerials and specialised reception. All are listed from time to time in short-wave listener publications.

Canada

Canada has, in the writer's opinion, one of the best and most consistent short-wave broadcast networks. During the greater part of the year the transmissions radiated by the CBC can be heard on various frequencies when directed to this country. This applies to all types of receivers used. The high-power transmitters used to-day in conjunction with beam arrays account in large measure for such consistent reception.

While there were several low-power transmitters on the air during the periods covered by the old log books, receiving the transmissions radiated was by no means easy or consistent. Among a total of twenty stations listed as of then high-power, not one Canadian station was included. CFCX Montreal and several others listed were heard, but generally at poor volume and with bad fading. VE9DR Drummondville, however, was the most consistent and relayed main station programmes.

VE9DR was a Canadian Marconi station, and the QSL card pictured a gigantic control room with a number of transmitters lining the sides.

Australia

So far as Australian transmissions are concerned reception of the early low-power transmissions was usually good. Amongst those verified were 3LR 600 watts, 2FC and VK2ME, the latter using 20 kW.

Nowadays, America, Canada and Australia radiate regular scheduled programmes which are received with ease under normal receiving conditions, and this being so can no longer be regarded as DX.

Rocky Point, which had a forest of aerials, a large number of transmitters, and a long list of assigned frequencies was a hot favourite, and could be heard working 'phone with ships, including *Empress of Britain* GMBJ, *Olympic* G2GN, a call by the way now held by a Chelmsford amateur, and several other big liners.

The chief interests so far as these ship-to-shore transmissions were concerned centred on the technical conversation which ensued during the contacts.

Usually, when tuned to a ship transmission the position of the vessel was given to the shore station operator. This enabled the listener to refer to his world map and find out just how far across the Atlantic it happened to be at the time.

One liner regularly gave the position on schedule at 9 p.m., and the distance covered in 24 hours was surprising. The writer remembers hearing the *Olympic* working WOW when in Lat. 44°, 58' N., 35°, 81' W.

All the big liners, as they were fitted with ship-to-shore telephony apparatus, were followed during the testing-out period. *Leviathan*, *Majestic*, *Aquitania*

Monarch of Bermuda. The SS *Belganland* being followed in this way while on a world cruise. The *Berengavia* was also heard.

Included in the list were the well-known Italian and French liners, as well as those of Germany. The French *Normandy* on her maiden trip was heard when 600 miles out from Southampton.

Little Ships

In due course both ships and shore stations were fitted with speech inversion apparatus, and apart from occasions when the operator used position B in which the inverter is out of circuit, one seldom heard those stations or verified them with certainty.

Having in the meantime discovered the trawler 'phones, attention was paid to the smaller craft. These included *The Rudyard Kipling* and *St. Roland* which, I believe, are still to be heard. There were dozens of others, some of which were at times off Bear Island, the coast of Greenland and Iceland respectively, together with some up in the White Sea area.

The modern counterpart to this type of listening is to tune for maritime mobiles which are American 10 metres amateur stations aboard ship, as per *Flying Enterprise*.

Outstanding Broadcasts

Amongst what the writer considers the most outstanding short-wave broadcasts heard, considering the period and receivers used, was the arrival of the German Graf Zeppelin at Lakehurst, Los Angeles. The outside broadcast was radiated from 2XAD on 19.56 metres. Three 'planes were flying over the hangar ready to meet the airship as it approached in an easterly direction with a fine bank of cloud behind it.

Three biplanes and eight monoplanes completed the escort, one of the former being a five-engined machine. 'Phone conversation was a little later heard in German, and was thought at the time to be from the airship to ground.

It was at this period of listening activity that I turned my attention to the building of a three-valve receiver using triode detector, R.C.C., and transformer-coupled L.F. stages, also to directional aerials.

This combination provided reasonably good loud-speaker reception under favourable conditions. Later, this set was rebuilt into a metal cabinet. Other events of interest via 2XAD was the arrival of the multi-engined German aircraft DO-X in New York harbour, also the arrival of the Italian so-called air armada at Chicago. When the England to Australia flight was under way, news as to the progress of the competitors was received through various channels.

During my years of active, consistent listening, many famous personalities were heard, including several pioneer airmen and other record-breakers. The most outstanding of all was the Marchese Marconi heard on two occasions during the testing out of HVJ, and at the official opening of that station. M. Mathieu, who was associated with Marconi in his experiments aboard his floating laboratory, the steam yacht *Electra*, was also heard on occasion.

Listening to test transmissions from new stations used to be very interesting, especially when working duplex with others in this country, U.S.A., Australia, Canada, and South America, the listener as well as the engineers gaining an idea as to the potentialities of the transmitter in use.

Aircraft

Unlike American listeners who had transcontinental air service 'planes and ground stations to search for, our listening depended on picking up a chance transmission from service aircraft.

Among those logged were some tests between aircraft and ground while the former were flying over Dublin Bay at 2,000ft. and 6,000ft. This was in June 1930. Signals were at R4QSA3 at 2,000ft.; a complete fade-out occurred at 6,000ft.

If this was a service aircraft, I wonder what type of low-power transmitter was in use. The TR9, I believe, dates back to that year. The wavelength used, however, was between 150-160 metres, and it may be that a preceding model was in use or a special variant of the TR9. Not bad for low power in any case.

Good Conditions

Receiving conditions generally were much superior than in recent years due, of course, to the fact that we were in a more favourable phase of the eleven-year cycle. This enabled one to obtain loudspeaker reception of the transmissions radiated by Dutch East Indies' stations PLE and PMA, etc.

The same applies to a number of South American stations, including LSX Buenos Aires, 20 kW C.O.C.D., Habana Cuba, 48.92 metres, YVQ Maracay Venezuela, PRA3 Rio de Janeiro, Brazil, and dozens of others throughout the world. PRA3 and PRBA were run by the radio club of that country and the Companhia Radio Internacional.

Simple Apparatus

This article, based on old log books as the source of reference, is but a fraction of what they contain in the way of entries. For example, long-period reports were appreciated at that time by station authorities, and we have data concerning such reports as sent to America, Australia, Java and others. The lowest-powered short-wave broadcast transmitter heard was VP3MR using 150 watts of Georgetown, British Guiana.

The aerials used covered almost everything from a 15ft. wire to a 2ft. sided frame, with set coupled end-on, all indoor types. I note a QSL card for VE-9HX, the Halifax short-wave relay of the Canadian CHNO. This dates with the putting into commission of the first directional aerial used at this location.

Some are apt to decry the relaxation of sitting down and tuning in short-wave broadcasts, and are all for listening to amateur transmissions, and would have everyone else do the same. To my way of thinking there is nothing like mixing one's interests and listening to all kinds of transmissions, building experimental receivers and trying them out, together with a few aerial experiments thrown in.

In addition, it helps to take a spell away from radio. One comes back to it with renewed interest and increased enthusiasm. Taking the radio press as a guide, it would appear that the specialist short-wave broadcast listener is in the minority so far as reporters are concerned.

Newcomers to short-wave radio are prone to regard compilers of call-sign lists common to specialised publications as super experts.

The fact, however, remains that getting to know one's receiver, how to handle it, when to listen and where, are the only qualifications necessary plus, of course, plenty of time to devote to operating.

A Dual-Wave

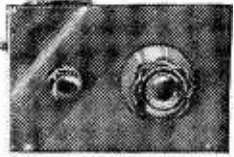

CRYSTAL DIODE RECEIVER

AN IDEAL SET FOR THE BEGINNER

By F. G. Rayer

THE crystal set has always enjoyed a certain measure of popularity, and such receivers have undoubtedly been constructed in large numbers over a period of many years. Modern developments have enabled the old-fashioned crystal detector, which had to be adjusted by hand, to be eliminated, but before going on to consider the kind of results which may be expected, the factors which have made crystal receivers so popular should be noted. Such a receiver forms a stand-by always ready for use when required and is, of course, wholly independent of any mains or battery supply. It therefore allows local programmes to be heard when the main receiver is out of commission, either from power cuts or other breakdown, or because batteries have run down and no replacement is at the moment available. Such a receiver can also be used in a bedroom, or when it is desired to listen to a certain programme personally. There are *no* running costs, and no licence is required when this is already obtained for another receiver. The initial cost is low, while circuit and constructional details are such that no difficulty whatever should be experienced by anyone making up the receiver, even if they have done no work of this kind before. Furthermore, if some wrong connection were made no damage is caused, and the receiver would work correctly when the error was rectified. This is by no means so with valve receivers, where valves or other components may, in some cases, be damaged by the application of wrong voltages, or other errors in connecting up.

Results to Expect

The receiver is simply switched on, as with a valve set, when required, a 3-way switch providing "Off,"

"Medium Wave" and "Long Wave" positions. The range at which transmissions may be picked up, and the volume obtained, depends to a large extent on local conditions, and particularly upon the aerial and earth system. Used in the Midlands, the receiver picked up a few of the more powerful continental stations with surprising strength; it also provided "Light" and "Home" programmes at excellent volume, and the Third programme at sufficient strength for prolonged listening with ease. These results were obtained with a 50ft. outdoor aerial, plus the usual earth. With the aerial removed, Home and Light programmes were audible but weak. With an indoor aerial volume was restored to a perfectly satisfactory level. The long outdoor aerial, with no earth, gave rather poor volume, which was still further reduced when using the indoor aerial alone. It is, therefore, very desirable that an earth connection be arranged, even if the receiver is used upstairs. An indoor aerial would be satisfactory in many areas for local reception.

These details should serve as a guide, but reception conditions vary throughout the country. In some areas the Third programme transmissions are not well received, even with a valve set.

Circuit Details

An air-cored coil of fairly large size is generally best for such a receiver, and has the added advantage that it can be wound easily by the constructor who

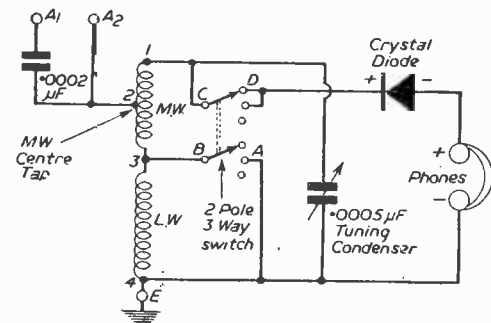

Fig. 1.—Circuit of the crystal receiver.

COMPONENTS FOR THE DUAL-WAVE "CRYSTAL DIODE."

- J.B. Standard .0005 μ F. tuning condenser with mounting feet. (Coventry Radio.)
- Type C1065.S. 2 $\frac{1}{2}$ in. knob. (Coventry Radio.)
- 7/8th in. diameter knob (Coventry Radio.)
- 2-pole 3-way wafer-type rotary switch. (Coventry Radio.)
- Five 4 B.A. terminals type C2512. (Coventry Radio.)
- .0002 μ F. fixed condenser (Dubilier, etc.). (Coventry Radio.)
- Crystal diode with mounting brackets. (Post Radio Supplies.)
- Brown Bakelite Panel 6in. x 4in. x $\frac{1}{8}$ in. thick. (Post Radio Supplies.)
- Terminal Strip 6in. x 1in. x 1/16in. (Post Radio Supplies.)
- Coil former 3in. by 1 $\frac{1}{2}$ in. diameter, 2 oz. 28 S.W.G. enamelled wire, and 2 oz. 34 S.W.G. D.S.C. wire. (Post Radio Supplies.)
- Wood for baseboard, screws, etc.

wishes to make his own coil. A compromise has to be made between selectivity and volume, and two aerial terminals are fitted so that the user can select that most suitable for local conditions. When aerial terminal "A2" is used the aerial is taken to a centre-tap on the medium-wave section of the coil, and this gives fair selectivity and good volume. Using terminal "A1" brings in a fixed condenser of .0002μF. This particularly increases selectivity on long waves, and helps to prevent long wave breakthrough where the receiver is used close to a long wave transmitter.

The receiver is switched off when not required as mentioned. The correct polarity is indicated for the "Phone" terminals because a steady direct current of about 50 microamperes flows, when the receiver is tuned to a local transmitter, and with some types

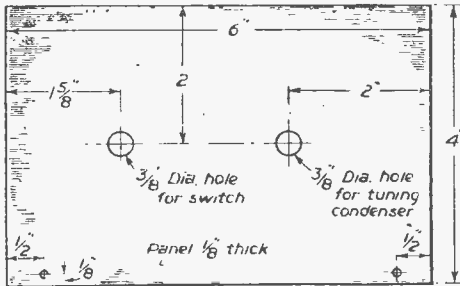

Fig. 2.—Details of the panel.

neat cabinet. The panel is 4in. by 6in. and the receiver 5 1/4 in. deep, excluding terminals. The polished brown bakelite panel specified ensures that the final appearance is satisfactory. No reduction drive is used with the tuning condenser, as this is scarcely necessary. The large knob, with skirt and engraved line, proves perfectly satisfactory for tuning. (The suppliers of this knob can also provide a knob with scale, and this could be used instead if the constructor prefers.)

In addition to the specified crystal diode, other similar detectors are available. The Sylvania 1N22 or CV102 may be used and have similar dimensions and characteristics. A second-hand detector (e.g., one taken from used ex-Service apparatus) is not

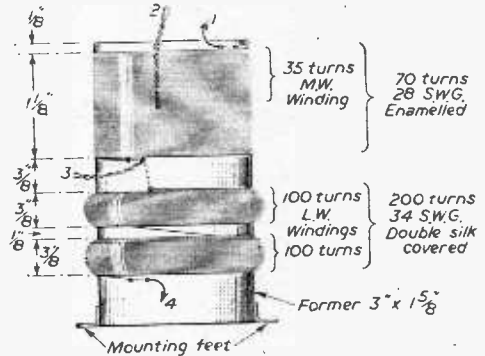
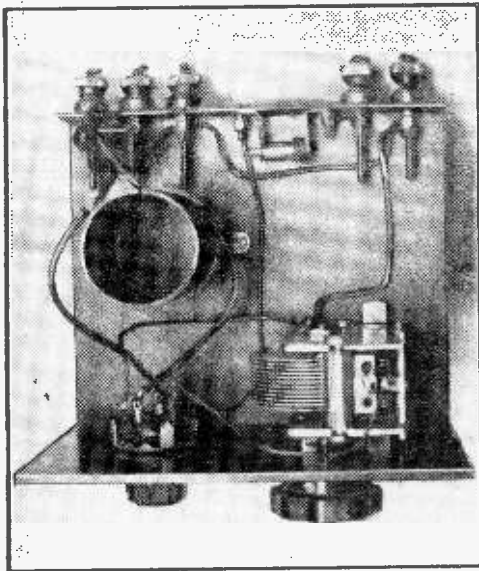

Fig. 3.—Coil data.

of headphones this could cause some slight eventual demagnetisation, if the phones were wrongly connected.

Points on Construction

The overall dimensions have been kept down so that the completed receiver can be housed in a small,



Plan view of the receiver.

recommended, as it may have been misused, or had its sensitivity reduced. When using the 1N22 type, the large end may need scraping because these have a screw which is subsequently covered with hard varnish so that no electrical contact may exist between the detector and mounting brackets.

In order that the tuning control may be in a central position, the tuning condenser is raised by 1/2 in., and this can be done by placing 1/2 in. bushes under the fixing brackets, or by placing a piece of wood roughly 2 in. square by 1/2 in. thick under the condenser before screwing it in position.

Rotary switches of the type illustrated are manufactured in certain sizes, and a lesser number of contacts than the maximum number which can be accommodated on the switch may be found. The same type of wafer is used for both 2, 3 and 4-pole switches. As only two poles are required, the other contact tags are ignored, if fitted to the switch. If they are not fitted, part of the wafer may appear blank. These points sometimes appear to confuse constructors who have never used this type of switch before, but if a 2-pole, 3-way switch is ordered they can be sure that this is suitable, and if extra contacts are found on the actual component, these are disregarded.

The diagram makes the construction of the coil quite clear. The dimensions between the respective windings are not critical, but given as a guide to the disposition of the windings. The ends are secured by passing them through small holes in the former, and should be left 4 in. or 5 in. long to reach to the various parts in the receiver. Point "2" is formed by making a loop in the wire, and point "3" will consist of two ends of wire, twisted together—the junction between medium- and long-wave sections of the coil. All turns must be wound in the same direction.

Aerial, Earth and Phones

The best aerial is a fairly long, outdoor one, situated as far as possible from buildings and other earthed objects, and as high as possible. However, circumstances often prevent such an aerial being erected, and good results can be obtained with other types. Whatever kind of aerial is used, it should be insulated by using one or two aerial insulators at the points of suspension. The down-lead should not descend against the house wall, but be kept a few feet away, if possible. Losses will then be avoided (and these can be severe in wet weather, if the down-lead is attached to brickwork), and signal pick-up increased. An average outdoor aerial could consist of about 50ft. of wire, this forming both the down-lead and horizontal portion. If space permits, a longer aerial can be used, with some slight increase in volume.

An indoor aerial can be made from any insulated wire, which is usually placed round the picture rail, against the wall. It is sufficient to take the wire along two walls of the room. If it can only be taken along one wall, sufficient volume may still be obtained, though the wire is then likely to be somewhat short. In a bedroom, results with the aerial at floor level will be found to be similar to those when the wire is near the ceiling. Under reasonable conditions an indoor aerial should be satisfactory. However, it cannot provide as much signal pick-up as a good outdoor aerial. If the building has a metal fabric or steel framework then an outdoor aerial is likely to be essential.

The earth lead should be taken to a metal object actually buried out of doors. Earthing spikes are obtainable for this purpose, or the wire may be securely attached to any metal object (preferably of a

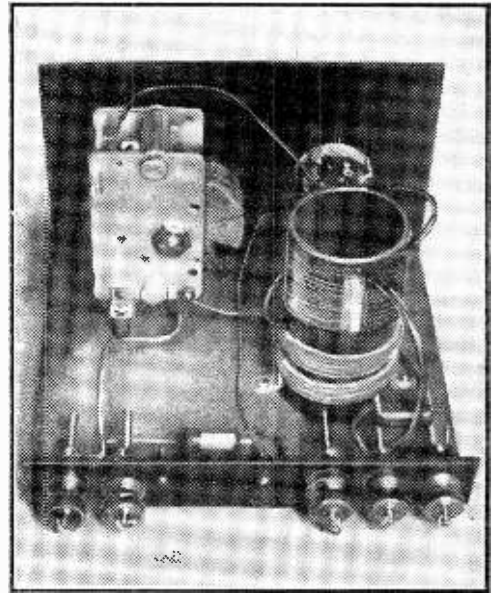

Another view of the receiver.

type not likely to corrode). In some cases an earthing point may be available in the house, or a descending water main can be used.

A wide variety of headphones can be operated with success, but low impedance headphones are not suitable.

Balanced-armature headphones, now readily obtainable, are satisfactory; so are medium- and high-impedance phones of all types. Moving-coil phones are not suitable, being of low impedance. If it is particularly desired to use such phones, or other low-impedance types which may be to hand, then a matching transformer is required. The primary of this should be connected to the phone terminals on the receiver, and the headphones should be taken to the transformer secondary. The transformer *must* be of correct type for the phones used; if it is not, volume will be reduced. The usual speaker-matching transformer is *not* suitable for most moving-coil phones, as the latter are of somewhat higher impedance than the normal loudspeaker.

A ready-made cabinet for the receiver may be obtained from James Tallon & Sons, Ltd., Manor Works, Manor Road, Rugby.

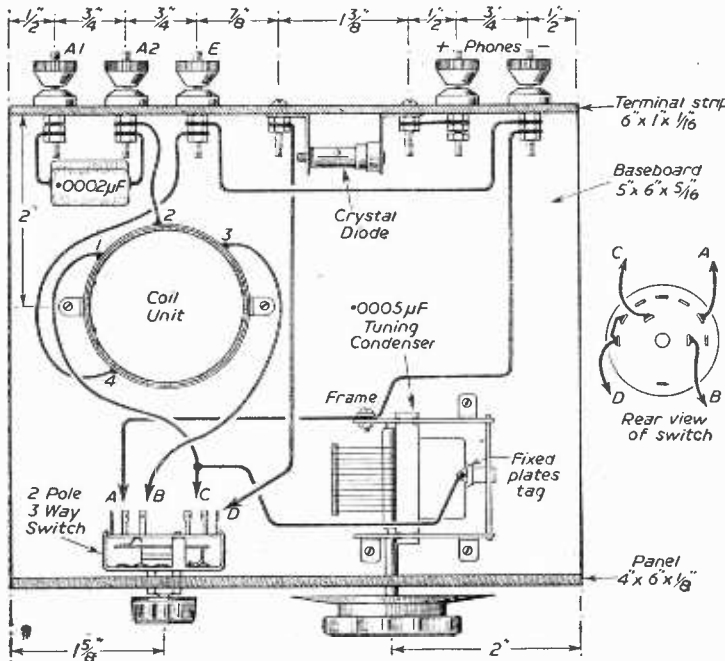

Fig. 4.—Wiring diagram of the receiver and switch.

TRANSMITTING TOPICS



MORE ABOUT SUPER-MODULATION By Wm. A. Hope

FOLLOWING the author's recent article in PRACTICAL WIRELESS, he has heard of the difficulties which have, unfortunately, dissuaded the potential constructor from using this system. The chief difficulty encountered is that of tuning up the transmitter and, at the same time, obtaining a good match between the aerial system and the P.A./P.M. stages. The purpose of this article is to clear up any difficulties on the subject.

Carrier Spreading

This is experienced when the aerial is over-coupled to the output stage of the transmitter; thus, there exists a mis-match between the radiating system and the P.A./P.M. stages. If the aerial coupling to the P.A./P.M. stages is too loose, the maximum P.M. efficiency will not be obtained. Thus, it will be seen that the degree of coupling which exists between the output stage of the transmitter and the aerial is a deciding factor when S.M. is to be used. If the P.A. valve is not operating under normal Class C conditions, the result will be a slight spreading of the carrier. Bad "splattering" off the side-bands can be remedied by checking that the R.F. drive and the audio volts to the P.A. valve are correct for the valve in question. When there is too little R.F. drive on the P.A. grid, this (assuming the audio volts input to be negative going) will cause the R.F. output to reach zero before the peak I_a of the P.M. valve has reached maximum.

Aerial Coupling

Now we come to the tricky part of the setting-up procedure—namely, the aerial coupling. The tank circuit should be tuned to resonance as indicated by the minimum of "dip." This "dip," in practice, is found to be higher than that of the normal P.A. The aerial loading is now increased until the P.A. draws maximum current and the drive and bias to the P.A. adjusted until the P.A. is operating at about three-quarters of its C.W. rating. It should be stressed here that these operations should be done with the transmitter output connected to a resistive load equal to the characteristic impedance of the aerial system. This ensures that the load on the P.A. stage is constant during the initial "loading" procedure. Once the P.A./P.M. stage has been correctly matched to the

aerial system, the operator will find that readjustment is not normally required.

Transmitter Adjustments

Because of the "sharp" tuning of the P.A., any variation in the V.F.O. frequency will cause the tank circuit to be re-tuned. If R.F. ammeters are employed in the feeders, then it is only a question of tuning the P.A. until the feeder currents reach a maximum. On no account should the loading on the tank circuit be adjusted, as this will cause a mismatch and previous time and patience will have been wasted. The modulator should be switched on and the audio gain control advanced until there is an upward "kick" in the P.M. I_a as registered by the P.M. milliammeter. It should be noticed, however, that this current reading must not reach a value greater than that stipulated for the valve in question. The reverse is the case with regard to the P.A. valve. There will be a decrease in I_a , which should not be less than one-quarter of the valve I_a under C.W. conditions. If this does happen, the audio volts must be reduced or, alternatively, the R.V. drive must be increased. This, however, should not be experienced if due care has been taken while setting up.

Final Points

The author, in writing this article, assumes that the V.F.O., buffer and P.A. stages of the transmitter are stable. This point should be ascertained before considering super-modulation, as instability can produce many phenomena when using this system; and much valuable time is wasted in trying to find a remedy. Critical voltages such as the V_a of the oscillator and the S.G. potentials of the P.A./P.M. valves should, where possible, be well regulated, as this will help no end in the overall efficiency of the super-modulation system. Finally, the author hopes that some points, regarding the transmitter setting-up procedure, have been clarified here and will be glad to help anyone who comes up against any major problems dealing with the operation or construction of this modulation system.

WIRELESS COILS, CHOKES AND TRANSFORMERS

8th Edition now ready.

Price 6/- by post 6/6d.



THE



Electronic Organ

COMPLETE CONSTRUCTIONAL DATA FOR
A MONOPHONIC 4-OCTAVE INSTRUMENT
FOR DOMESTIC OR PROFESSIONAL USE

By W. J. Delaney (G2FMY)

THE modern electronic organ is of two main types, the larger having a full-size keyboard similar to a piano or standard organ and capable of playing chordal effects, and the smaller having a fore-shortened keyboard and capable of playing single notes only. The first type is known as a polyphonic and the second a monophonic, and to increase the utility of the latter special tone circuits are associated with it, in most cases these being designed to resemble normal orchestral instruments. This type of instrument is primarily intended to be used by a pianist in conjunction with the piano, the right hand picking out the melody with suitable tonal effects whilst the left hand continues the piano accompaniment. In a small orchestra it may be used to augment the general tone of the instruments employed in the combination. We have received many requests from time to time for constructional details of an organ, and although we have in the past given general articles on the subject we have not so far published a constructional feature on either type. We have accordingly carried out some experiments with various arrangements, and in view of the economy of the monophonic type have produced a simple instrument which, for domestic purposes, needs only five valves plus rectifier, and it may be adapted for professional use with only three additional valves. The cost of the domestic model would be about £15, and the professional model a few pounds more. The main difficulty with any form of organ is, of course, the obtaining of a suitable keyboard, and although it may be possible for some readers to get hold of discarded accordion keyboards, it appears that most constructors will have to make up their own, and in this design the

construction is of the very simplest and does not call for workshop facilities.

Features

The organ has a two-octave keyboard which may be pitched by the constructor to correspond with any desired part of the piano keyboard. The central switch on the control panel gives three separate octave ranges (bass, tenor and soprano), and in conjunction with the keyboard this means that the overall compass of the instrument is four octaves. There are five separate tonal switches which may be used singly or in combination, thus producing dozens of different effects, and in conjunction with these is a separate switch which, by the addition of certain

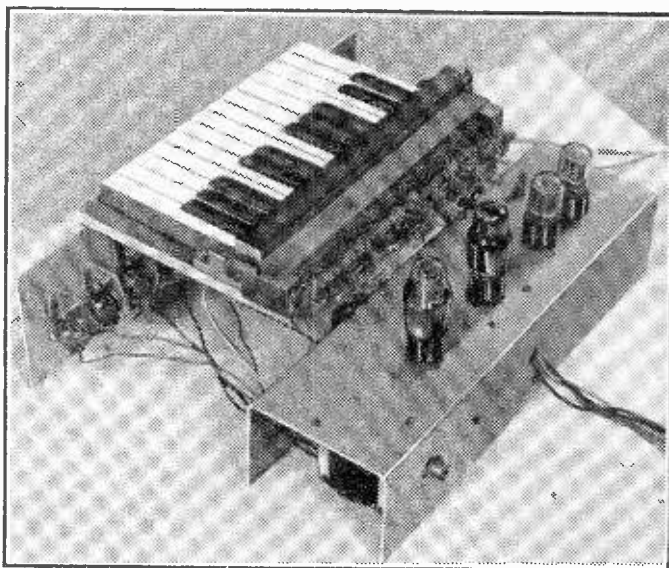

View of the keyboard and main chassis which is a self-contained unit.

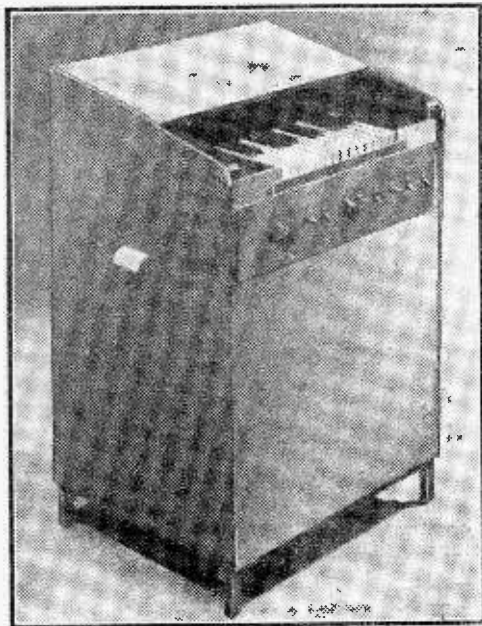

The player's view of the organ.

harmonics, changes the overall tone of the entire instrument. For want of a name I have called this a "strings/woodwind" switch, although strictly it does not make the reproduction resemble these types of instrument. In one position, however, the tone might be described as "hard" and in the other "soft," and this increases the usefulness of the tone

LIST OF C

- RESISTORS** (all $\frac{1}{2}$ watt, except 1 as stated)
- One at $150\ \Omega$
 - Two at $1k\ \Omega$
 - One at $1.5k\ \Omega$
 - Three at $2.2k\ \Omega$
 - Four at $10k\ \Omega$
 - One at $15k\ \Omega$
 - Five at $22k\ \Omega$
 - Three at $47k\ \Omega$
 - Four at $100k\ \Omega$
 - One at $470k\ \Omega$
 - One at $.5M\ \Omega$
 - One at $1M\ \Omega$
 - One at $5k\ \Omega$ (1 watt)
 - R11, and R_a to R_x (see text)
- (Dubilier, Erie, etc.)

- CONDENSERS**
- One at $500\ \mu F$
 - One at $.005\ \mu F$
 - One at $.01\ \mu F$
 - Two at $.02\ \mu F$
 - Three $8\ \mu F$ electrolytics 500 w. working.
 - One $32\ \mu F$ electrolytic 500 w. working.
 - One $16\ \mu F$ electrolytic 500 w. working.
 - Two $50\ \mu F$, 12v. or 25v. working (T.C.C., Dubilier, etc.).
 - Five at $.1\ \mu F$
 - One at $.15\ \mu F$
 - One at $.25\ \mu F$ (or two $.1\ \mu F$ in parallel)

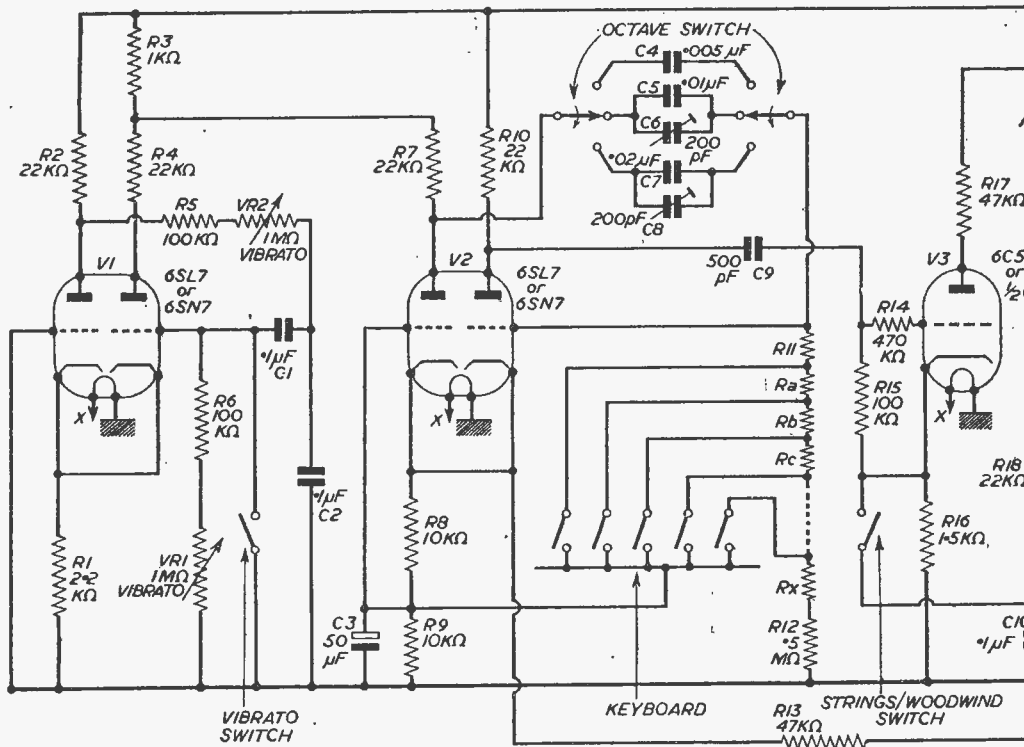
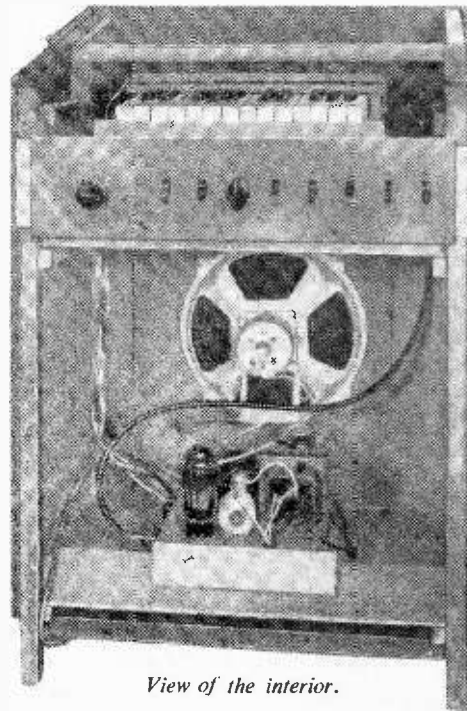

Fig. 1.—Theoretical circuit of the organ

switches. Finally, vibrato may be added as desired by the remaining control; and although this is pre-set there is no reason why it should not be brought out to a panel control, either as a variable or as a two- or three-position switch so that different speeds of vibrato may be added as desired. The volume or "swell" control is of the ordinary knob

COMPONENTS

- Two 200 pF trimmers (see text)
- Seven key type on/off switches (see text) } Smith's Radio
- Small push-pull output transformer, L1.
- H.F. choke, Type HF9s (L2)
- One 5-way tag, strip, Type T24
- Two 2-way tag, strips, Type T17
- One octal plug, Type P.112
- Seven octal valveholders (Clix).
- Mains transformer (250-0-250 at 80 mA ; 6.3v. at 3A. and 5v. at 2A.) (Wearite).
- Smoothing choke, 10 to 20 henries at 80 mA.
- One DRM3B selenium rectifier (or two RM/3 in series) (Standard Telephones & Cables).
- 2-pole 3-way Wafer type switch.
- Extension control Type N.630 (Eddystone).
- Coaxial plugs and sockets, two each, Types L604/S and L734/P (Belling & Lee).
- One Stentorian Duplex 10in. loudspeaker (W.B.).
- Two 6SL7s or 6SN7s; two 6CSs or L63s; one EL33 and one 5Z4.
- Chassis, connecting wire, screws, etc.



View of the interior.

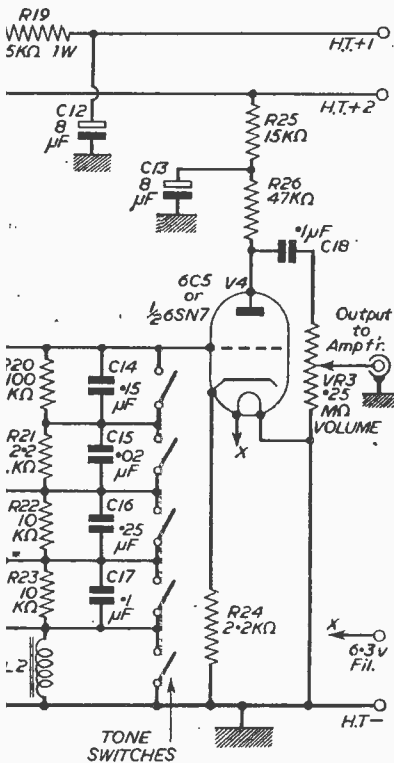

Restic type amplifier and power pack.

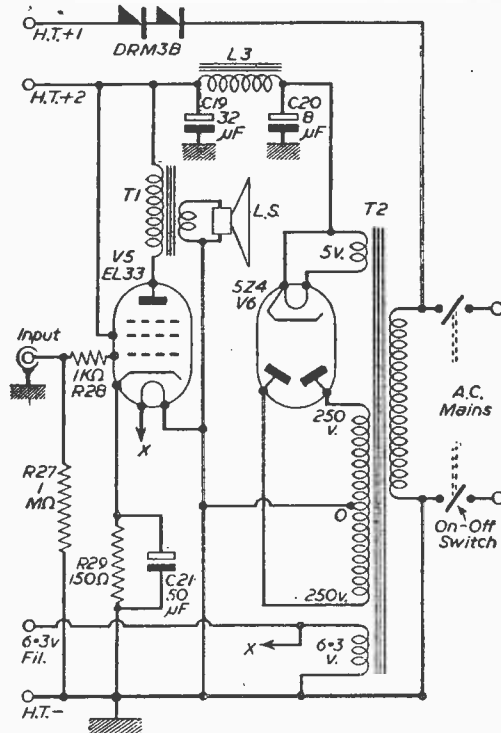

controlled type, but again, if desired, this may be foot-operated and its place on the panel taken by a jack into which a plug from the foot-control may be inserted. There is ample scope in the design for improvements, and work is at present being carried out on the design with a view to producing a "de-luxe" type of instrument, details of which will be published if it is found to be in demand.

The Circuit

In the circuit V2 is the "note generator" stage, a simple multivibrator with variable grid and anode components to cover the desired ranges, and this with V1, which is the vibrator generator, are based on the arrangement described some years ago in these pages by Mr. F. C. Blake. The arrangement is fool-proof and very easy to set up, although it calls for a little patience to get the pitch of every note correct. To avoid frequency shift when adjusting volume or tone switches these two stages, which as will be seen, both utilise double triodes, are fed from a half-wave rectifier and do not carry the current of any other part of the circuit. Two alternative arrangements are possible here, the arrangement shown in Fig. 1 having the drawback that the main chassis is "live" to one side of the mains, but by utilising a separate control panel as shown in the illustrations, together with a special extension for the octave switch, the panel is "dead" and there are no live controls. If, however, it is thought desirable, a separate 1-to-1 mains transformer may be used to feed these stages, and the modification is shown in Fig. 2. The stability is of a high order, and it will be found that a key may be pressed, the instrument switched on with the volume control at its maximum position, and as the valves warm up the note will be heard at correct pitch from the moment it becomes audible, right up to maximum volume, and any desired combination of tone or volume or vibrato may be used without the slightest variation in pitch.

There are a number of separate resistors in the grid circuit of the second half of V2 and the junction of each of these is connected to a separate key on the keyboard, with a common "earth return." V2 is biased to cut-off by R9, and when any key is pressed, R11, plus any resistors between it and the key in question, are joined across the grid circuit and control the frequency of oscillation. If all musical notes were mathematically related it would be possible to specify so many 1,000 or 2,000 ohms resistors—for instance, for inclusion between each adjacent key—

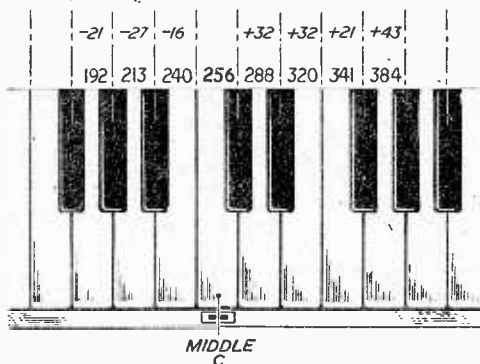

Fig. 3—Relative frequencies of one octave.

but, as may be seen from Fig. 3, the difference between the notes on the piano is not constant, and this means that all kinds of odd values have to be used for Ra, Rb, etc. The method of arriving at these will be described later. R11 is set to produce the highest note which is required, and the keyboard may be set up to coincide with the centre of the piano or with the octave above as desired.

There are two outputs from V2, the anode being taken in the usual way to a simple triode, and the

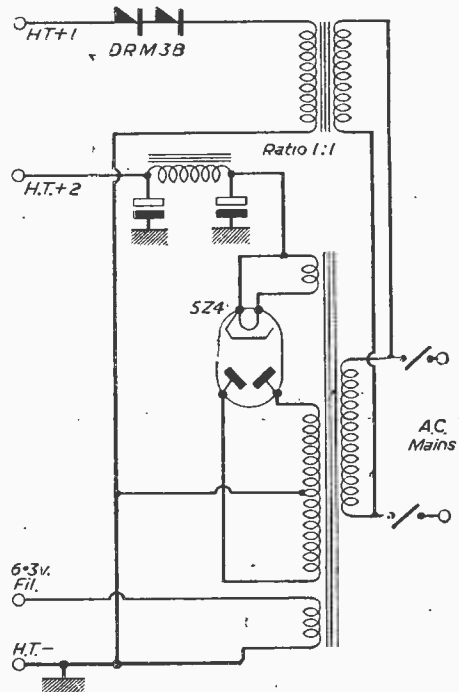

Fig. 2.—Alternative arrangement for feeding selenium rectifier.

main output being taken from the common cathodes. This is fed, with suitable stoppers, to the grid of the single L.F. stage which is used to produce the various tones, but the output from V3, also on the cathode-follower principle, is also taken, through a switch, to the grid of the L.F. stage, and the difference in phase and harmonic relationship produces the desired change in tone. In the tone-control stage, which is an adaptation of the popular Hammond Solovox arrangement, the normal grid-leak is replaced by four separate resistors in series with an iron-cored H.F. choke (L2), and across each of the resistors is a fixed condenser and short-circuiting switch. In addition, across two of the resistors is a centre-tapped L.F. choke (L1), actually a push-pull output transformer with the secondary ignored. As the two halves of this component are identical and the two associated resistors are also identical, it is possible to make both circuits harmonically related, and although C16 is specified as .25 μ F, this is only because this is a standard value, and two .1 μ F condensers in parallel, may be used.

(To be continued)



OPEN TILL 6 PM SATURDAYS

TELEPHONES: AMBASSADOR 4033 & PADDINGTON 3271/2

PREMIER RADIO Company

(REGRD) B. H. MORRIS & CO (RADIO) LTD. EST. 40 YRS.

THIS IS OUR ONLY ADDRESS (Dept. P.W.) 207 • EDGWARE ROAD • LONDON • W2 (THIS IS OUR ONLY ADDRESS)

BALANCED ARMATURE LOW RESISTANCE HEADPHONES. Type 1, 5/11 pair. Type 2, 9/11 pair.
HIGH RESISTANCE HEADPHONES. 12/6 pair.
LIGHTWEIGHT HIGH RESISTANCE HEADPHONES. 14/6 pair.
BRAND NEW R1155 RECEIVERS, in original cases, complete with 10 valves, £11. 19s. 6d. 10/6 Packing and carriage.
THREE PIECE AERIALS—Brand New.
 12ft.—3 4ft. screw-in sections of copper-plated steel, highly flexible with non-stick screw fits, tapering 3in. to 1in. Brand new in container, 6/9. Also plug-in type, 4/9. Packing and carriage, 1/6. Insulated Base, 3/-.

BUILD A PROFESSIONAL-LOOKING RADIO AT LESS THAN HALF TO-DAY'S PRICE

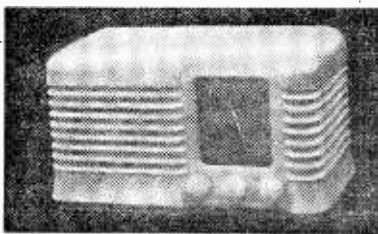

We can supply all the parts to help you. Bakelite Cabinet (Brown or Ivory), 17/6. Packing and insurance, 2/6.
 Punched Chassis, 3 valve plus rectifier T.R.F., 3/9
 Engraved Glass Dial, 180-550 and 800-2,200 m. with station names, new wavebands. 1/6
T.R.F. COILS 180-550, 800-2,200 metres, pair 6/6
 Drum (2 1/2 in. diam.) 1/6
 Driving Head 1/6
 Double Pointer 4/6
 Spring 3/6
 Nylon Cord (yard) 6/6
 Dial Front Plate 2/6

SEND 1/6 FOR EASY-TO-FOLLOW POINT-TO-POINT DIAGRAMS AND CIRCUIT DIAGRAM, which show you HOW YOU can build the Receiver illustrated at HALF TO-DAY'S PRICE.

THE COMPLETE KIT to construct a 3-valve plus rectifier TRF Receiver for use on 200/250 v. A.C. mains can be supplied at £6. 9s. 6d., plus 2/6 packing and carriage.
 Each Kit is complete in every detail, nothing has to be made or improvised. Easy-to-follow, point-to-point diagrams are supplied, making construction very simple. The Dial is illuminated and the Receiver, housed in a Bakelite Cabinet size 12in. x 5in. x 6in., presents an attractive appearance. The valve line-up is 7TA—H.F. Pentode, VR 116—Detector, ATP4—Output, and Metal Rectifier.

Waveband coverage is for the medium and long bands. Choice of Walnut or Ivory-coloured Cabinet.

EX U.S.A. U.H.F. AERIAL, with Untuned Detector Stage consisting of VR92 Valve. Brand new, 5/-.

CRYSTAL MICROPHONE

An entirely insulated crystal microphone which can be safely used on A.C./D.C. amplifiers. High impedance. No background noise, really natural tone. The ideal Mike for tape, wire and disc recording and sound projectors. Price 22/6.

AVAILABLE ONCE AGAIN!
A.C.R. 1 C.R. TUBES. (Direct Replacement for A.C.R. 2X) Data Sheet Supplied. 51in. Screen. 4 Volt Heater. This Electrostatic Tube is recommended as eminently suitable for Television. 15/- plus 2/6 Pkg., Carr. and Ins.
V.C.R. 97 C.R. TUBES.
 We are once again able to offer this famous tube with the usual PREMIER guarantee of a full screen picture, free from cut-off. Every tube is television picture tested before despatch. Price £2/5/-, post paid.

TERMS OF BUSINESS: CASH WITH ORDER OR C.O.D. OVER £1. Please add 1/- Post for Orders under 10/-, 1/6 under 40/-, unless otherwise stated.
NOTE: Prices quoted are those ruling at the time of going to press, and are subject to alteration without notice.

GARLAND BROS. LTD

CHESHAM HOUSE, DEPTFORD BROADWAY, S.E.8. TEL: TIDEWAY 4412/3
 5 OBELISK PARADE, LEWISHAM, S.E.13. TEL: LEE GREEN 4038

THE 'GARLAND' TAPE RECORDER

£37/10/0

Including a 1,200ft. reel of Scotch Boy Tape and a spare spool. Carriage, etc., 15/-.
 Crate £1 (not charged if you undertake to return carriage paid to us). No wiring or soldering to be done—just plug in and record and play back from Radio, mike or pick-up. Incorporating the new Lane Tape Table and the new Lane Amplifier, housed in a de luxe walnut veneered cabinet and supplied complete with a 1,200ft. reel of tape and a spare spool. **GARLAND KIT FOR THIS RECORDER £32/5/-** plus carr. and crate as above.

AMPLIFIER A.C.II

This popular amplifier is still available for those who desire good quality at a low cost. Output is 4 watts, and volume and tone controls are incorporated. High grade output transformer. H.T. and L.T. supplies are from mains transformer. Amplifier-wired and tested. £6/2/6. Plus 5/- carriage. ***GARLAND KIT FOR THIS AMPLIFIER £5/2/6**, plus 5/- carriage.

THE NEW LANE TAPE TABLE

A new version of the popular "Lane." Three motors, very fast wind-on and rewind (under one minute); heads are high impedance on mu-metal laminations, with half-thou. gap, giving a half-hour playing time on each side of a 1,200ft. tape reel. Plus 10/- carriage. £16/10/0.

COLLARO HIGH TORQUE MOTORS

4-pole shaded pole; 1,500 r.p.m.; for A.C., tapped 100-125 v. and 200-250 v. State if clockwise or anti-clockwise required. Ideal for tape recorders, fans, etc. 37/6.

MOTEK RECORD-PLAYBACK AND ERASE HEADS

High impedance (1,000 ohm) chromium-plated enclosed type. Genuine half-track with half-thou. gap of beryllium copper. Record play-back heads are wound on Mu-metal laminations, and Erase Heads on Radiometal. Single hole fixing enables ready use for replacement purposes or for conversion of existing tape decks to high impedance. Wide frequency range. Pressure pads not required. Price either type, 39/6.

CATHODE RAY TUBES

Electrostatic focusing and deflection; 5in. diameter; second anode voltage, 2 kV, max.; intensifier, 4 kV, max. Exactly as specified for the "Television Oscilloscope" described in the June and July issues of "Wireless World". Brand new in original crate or carton, 32/6 each.

MAINS TRANSFORMERS

All primaries 200-220-240 v.
 MT1: 250-0-250 v. 80 mA., 0-4-6.3 v. 3 a., 0-4-5 v. 2 a., 20/- each.
 MT2: 350-0-350 v. 80 mA., 0-4-6.3 v. 3a., 0-4-5 v. 2 a., 20/- each.
 MT3: 0-30 v., tapped to give 3 v., 4 v., 5 v., 6 v., 8 v., 9 v., 10 v., 12 v., 15 v., 18 v., 20 v., 24 v., 30 v., all at 2 a. The ideal model-makers transformer. 19/6.
 MT4: Charger-tfmr., 0-4 v. 4 a., 10 v. 4 a., 20 v. 3 a., 19/6.
 MT5: Auto; 0-10-120-200-230-250 v. at 100 w., 19/6.
 137: Heavy-duty shrouded; 250-0-250 v. 120 mA., 6.3 v. 7 a., 5 v. 5 a., 37/6.
 190: Heavy-duty shrouded; 350-0-350 v. 120 mA., 6.3 v. 5 a. C.T., 5 v. 5 a., 42/6.

METAL RECTIFIERS

Type MR2, 125 v. at 100 mA. Two in series required for mains voltage. Price 4/- each. Type 14D/1972, 250 v. 25 mA. (with reservoir condenser). Small size ideal for test equipment, also in place of 14D/36 in TIV circuits. Price 6/6 each. 6 v. 1 a. half-wave (or full wave with C.T. tfmr.), price 5/- each; 12 v. 1 a. bridge, price 8/6 each; 12 v. 4 a. bridge, price 22/6.

DE LUXE TAPE RECORDER CABINETS

Veneered walnut, to take UE7 Amplifier and Lane Tape Table. £6.

GARLAND BROS.—Please send Post Orders to Deptford Branch

— YOU CAN RELY ON US —

FILAMENT TRANSFORMERS.—200/240 v. tapped to 6.3 1½ amp. midget, 8/6; multi-secondary, 3 v. to 30 v. at 2 a., tapped primary, 24/-.

COILS.—Wearite "P" coils, 3/- each full range; Weymouth "H" coils, 2/6; "K" coils, 4/9; CT2W2, 10/6 pair; CS3W3, 12/3 pair; MW/LW TRF pair with reaction, 7/6; Viewmaster coils for London, 22/-; Birmingham, 28/-; Holme Moss, 28/-; Electronic Holme Moss coils, 19/6; L9 Viewmaster choke coil, 2/-.

RECTIFIERS.—WX6 3/9; WX3, 3/9; 14D36, 11/6; 14A86, 20/-; 3/6 EHT 100, 29/-; 5 ma 12 v., 1/-; 12 v. 1 a., 7/6.

HIGH VOLTAGE CONDENSERS.—New T.C.C. .001 5 Kv., 6/-; .001 12 Kv., 10/-; 1 mfd. 5 Kv., .01 mfd. 6 Kv., 10/-; .01 mfd. 5 Kv., surplus, 3/6.

HIGH IMPEDANCE HEADPHONES.—New American surplus, unused, 12/6 pair. **CERAMIC TRIMMERS.**—50 pf., 9d.; 100 pf., 1/-; 150 pf. 1/-; 250 pf., 1/7; 500 pf., 2/-; 750 pf., 2/3; 1,000 pf., 2/6.

SPEAKER TRANSFORMERS.—Standard Pentode, 4/6; Midget Pentode, 4/-; Triode type, 4/6; Super Midget for IS4, 354 valves, 5/-; push-pull new transformers, PAX4 for two PX4 in p/pull, 10 watts, 35/-; 15 watt, push-pull, 6L6, primary 5,000 secondary 15, 7.5, 3.75 or 2.5, 42/-; Multi-ratio OP transformers, MR7, 14, 18, 19, 22, 25 to 1, also 26, 36, 33, 44, 66, 100 to 1, centre-tapped, 7-10 watts, 13/9; Wharfedale, Type "P" 30, 45, 60, 90 to 1, 8/6; Elstone multi-ratio, 8/9.

MIDGET

Conds. .001, .002, .005, 1/3; .01 .02. 1 mfd., 1/6-
Twin-gangs .0005 with trimmers, 10/6.
Resistors, Midget, 6L, 1 w. and 1 w.
Valves, IS4, 9/-; IT4, 9/-; 3A4, 7/6; 1R5, 10/6.
I.F.s 465 kc/s very small, 21/- pair.
3in. Speaker, 14/3; 2in. WB, 17/3.
Weymouth midget iron-cored coils, 3/6.
50 pf trimmers, 9d.; 100 pf., 1/-.
BTG Holders, 1/-, with screen, 2/6.

T.C.C. METAL MUTES, METAL PACKS, VISCONAL CONDENSERS. All in stock. **ADCOLA SOLDERING IRON.**—Pencil bit, 22/6, state voltage.

MULLARD, BRIMAR, MARCONI/OSRAM Valve Manuals, 5/6 ea., post free.

4 v. 4 pin Rectifier valve, 125 ma 500 v., 8/6.
12AT7 Double triode noval based valve, 6 v. or 12 v. heater, 9/6.

EY51 EHT Rectifier valve, 12/6.

DH77 BTG base DD/Triode, 6.3 v., 8/6.

6AM6 Tele. Pent., BTG Base, 6.3 v., 9/-.

VR105 Stabilisor, 6/6.

2 v. Battery O/P Pen220A, 5/-.

3524, 9/6; 35L6GT, 10/6.

6L7 Metal, 7/-; 9D2, 6/-.

I.F. TRANSFORMERS.—RS/GB, 465 kc/s, 12/6 pair; midget Wearite M800, 21/- pair; supermidget, RRSR, 465 kc/s, 21/- pair.

VOLUME CONTROLS.—Standard, less switch, 2/9; with switch, 4/3; Midget types, 3/6 and 5/- with switch; Wirewound types, Colvern preset, 2/6; standard, 5/6. All standard valve stocked.

MAINS TRANSFORMERS.—SR/350 80 m/a 200/230/250 v. to 350/0/350 v. 6.3 v. 4 a. tapped at 4 v., 5 v. at 2 amps, tapped at 4 v., 28/6. SR/250 80 m/a as SR/350, but 250/0/250 v., 28/6. 80 m/a, Trans. 250/0/250 6.3 v. 3 a., 5 v. 2 a., small dimensions, 22/6.

SWITCHES.—4 pole 2 way, 4/-; 3 pole 4 way, 4/-; 2 pole, 6 way, 4/-; 1 pole 12 way, 4/-; 6 pole 3 way, 4/3; 4 pole 4 way, 3/6.

MISCELLANEOUS.—Octal valve cans, 1/6; Viewmaster envelope, 5/-; London, Birmingham, Holme Moss (state which) easy built televisor, 2/6; B.T.H. Germanium crystals, 5/6; Qmax cutters, 11in., 16/-; 1in., 12/4; 11in., 17/9; 2in., 13/4; all sizes stocked; Solon soldering iron, pencil bit, 22/6; oval bit, 21/-; State voltage.

VALVE HOLDERS.—Int. octal, 6d.; Mazda octal, 6d.; British 5 and 7 pin 6d.; local, 1/3; BTG, 1/-; EF50 (ceramic), 1/-; UX American, 6d.; B12A (duo-decal), 2/6; Noval (B9A), 1/-; B8A, 1/3.

TUBULAR CONDENSERS.—.001. .002. .005. .01. .02. .05. .1. 6d.

MICA.—.0001. .0002. .0003. .0005. .001. .002. .005, 6d.

RADIO SERVICING Co. 444, WANDSWORTH ROAD, LONDON, S.W.8

Telephone: MACaulay 4155

Buses 77, 77a, 168, 169.

Open till 6.30 p.m., except Wednesday.



can help your career through personal postal tuition

in any of these subjects:

- Accoutancy Exams. ★ Aircraft Eng. & Radio ★ Architecture ★ Auditing ★ Book-keeping ★ Building ★ Carpentry ★ Chemistry ★ Civil Service ★ Commercial Art ★ Commercial Arithmetic ★ Company Law ★ Costing ★ Diesel Engines ★ Draughtsmanship ★ Electric Wiring ★ Engineering (Civil; Electrical; Mechanical; Motor; Steam; Structural) ★ Jigs, Tools & Fixtures ★ Journalism ★ Languages ★ Mathematics ★ Mining ★ Modern Business Methods ★ Plumbing ★ Police ★ Press Tool Work ★ Quantity Surveying ★ Radio ★ Salesmanship ★ Secretarial Exams. ★ Shorthand ★ Surveying ★ Telecommunications ★ Television Works Management ★ Workshop Practice

and GENERAL CERTIFICATE OF EDUCATION

SUCCESS WILL BE YOURS

As a Bennett College Student your own Personal Tutor will coach you until you qualify, at your pace, with no time wasted. You will learn quickly, easily.

SEND TODAY FOR A FREE PROSPECTUS

TO THE BENNETT COLLEGE, DEPT. 1.104, SHEFFIELD.

Please send me your prospectus on..... (Subject)

NAME

ADDRESS

..... AGE (IF UNDER 21).....

PLEASE WRITE IN BLOCK LETTERS

ARMY CARBON MICROPHONES complete with switch, 5/9. Matched transformer, 4/6.

NEW UNSPILLABLE EXIDE PO-2 accumulators, 11 A. H. 4½ x 3½ x 2in., 18/6.

TR1196 CIRCUIT AND CONVERSION DATA, 1/3. 1147A or B, 1/6.

New IN34 CRYSTAL DIODES, 5/6.

P.M. SPEAKERS, 8in. Rola, 20/-; 10in. Goodman, 31/6. 5in. Goodman, 14/6.

SELENIUM RECTIFIERS. H.W. 250v. 120 mA., 9/-; F.W. 6 or 12v. 4 A., 26/-; 6 A., 30/-; 3 A., 14/6; ½ A., 5/6.

TRANSFORMERS. 200-240 volts, tapped 3-4-5-6-8-9-10-12-15-18-20-24 and 30 volts at 2 A. 21/6.

TYPE 18 TRANS. CHASSIS, clean condition, partly stripped, 8/6 to clear.

10H./120 mA. BRASS SHROUDED CHOKES, 7/6.

T.C.C. TYPE CP58QO, .1 mfd. 7 kv. Condensers, 10/6.

M/C MICROPHONES, 7/6. Trans. to match, 5/-.

PRACTICE MORSE KEY AND BUZZER SETS, 7/6.

VC97 C.R. TUBES, picture tested, new and crated. 45/-; base, 3/6.

PHONES, High Resistance, 11/6; Low, 8/6.

TYPE IN34 GERMANIUM CRYSTAL DIODES, 5/6.

TUFNOL PANELS, 12in. x 8in. x ¼in., 4/6.

MINIATURE VALVES. New. DL72, CK512AX, 9/-; 9001, 9002, 9003, 7/6.

NEW 2 VOLT 10 A.H. EXIDE ACCUMULATORS, 6/6.

SPECIAL OFFER. Famous Type R103A New Communications Receiver 1.7-7.5 mc/s. Internal A.C. Power Pack and 6v. Vibrator Pack. Circuit supplied for easy conversion to M.W. and 14 mc/s bands £10. Only few available. Carriage Paid in England.

ALL POST PAID.

THE RADIO & ELECTRICAL MART

253b, Portobello Road, London, W.11

Phone: Park 6026

A Direct-reading Bridge

ANOTHER INTERESTING DESIGN WITH SOME NOVEL FEATURES

By Robert D. Paterson

OF the making of bridges as of books there would seem to be no end. Nevertheless, many practical interpretations of the bridge principle prove unsatisfactory in use because they lack comprehensiveness and readability. So the author offers no apology for putting forward yet another design which, though orthodox in theory, possesses both these characteristics in full.

There is no doubt of its comprehensiveness. Values of resistance, capacity and inductance from 10 ohms to 10 megohms, 10 pF to 1,000 μ F and 10 μ H to 100 H. can be measured with one movement of the range dial and another of the multiplier dial, while the single index mark which is common to both dials makes the instrument eminently readable. The reading is made from left to right just like a printed page. In the sketch of the panel (Fig. 2) the condenser being measured is $25 \times 0.1 \mu$ F.

The Theoretical Diagram

The theoretical diagram (Fig. 1) may at first sight appear to be complicated. In reality it is not so. The following individual circuits can be readily picked out: the energising unit, the indicator unit and the bridge proper. The last in its turn can be broken down into three types of bridge for the measurement of R, C, and L respectively. Setting the range dial to the required range not only selects the correct ratio

arms, but sets up the appropriate bridge network. These are set out in simplified form in Table 1, with the ranges obtained appended. The bridge in all its forms is energised from an audio source, either 50 c/s stepped down from the mains or a neon or valve oscillator. A null point indicator consisting of a magic eye preceded by an amplifying stage is incorporated.

The Bridge

A wire-wound variable resistor of 10 K Ω resistance, another of 20 K Ω , a 4 pole, 11-way range-selector switch and a set of six precision resistors and condensers compose the bridge proper. The 10 K Ω resistor which forms the variable arm must be of good quality, capable of being closely adjusted and free from back lash. It should preferably be of large diameter, say 3in. The 20 K Ω resistor is used to estimate the power factor of condensers and inductances. The bridge can be built with a variable ratio arm other than 10 K Ω but with less convenience. Either the ranges will be different and the multiplying factors fractional and liable to miscalculation, or else odd values of precision components will be needed, and these are difficult to obtain. A 10 K Ω resistor in conjunction with standards whose values are multiples or submultiples of 10 produces ranges which are convenient and easy to read. However

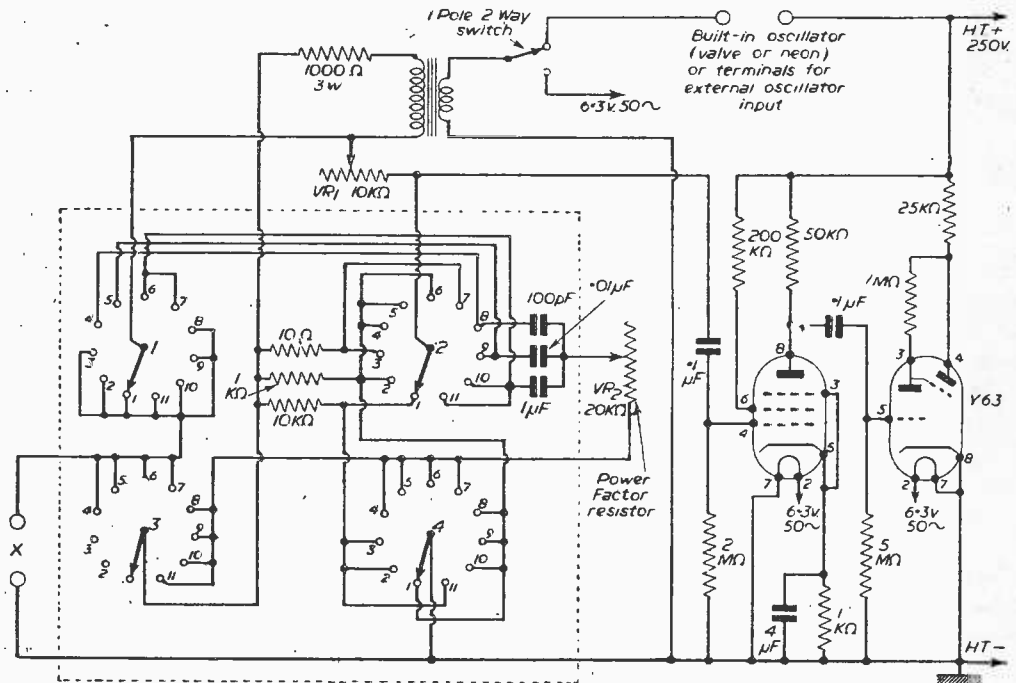

Fig. 1.—Theoretical circuit of the bridge described in this article.

if a variable resistor on hand is of a suitable type but measures a little more than 10 KΩ, it may be used, and the unnecessarily great overlap between ranges accepted as a necessary evil, or a fixed resistor of suitable value may be wired between the moving arm and the end (not the free end if it is a potentiometer) of the variable. The value of the required resistor can be calculated from Ohm's Law where :

$$\frac{1}{\text{required R}} = \frac{1}{10 \text{ K}\Omega} + \frac{1}{\text{present R}}$$

or by trial and error, using an ordinary D.C. resistance meter to adjust the combined value to 10 KΩ or

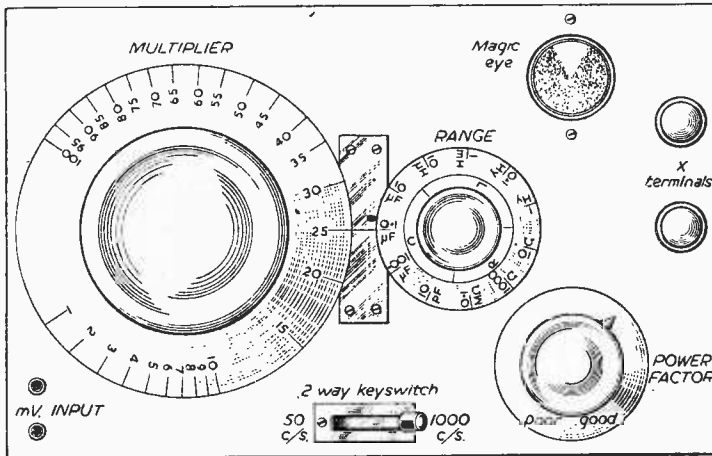

Fig. 2.—Suggested panel layout; the words in capital letters are inscribed on the panel, the others are just for guidance.

just over. Since the ranges are calculated upon using the variable resistor from its maximum value 10 KΩ down to one-hundredth part of the maximum, namely, 100 Ω, a nominal 10 KΩ resistor which is short of that value by less than 100 Ω can be pressed into service by inserting in series with it a fixed resistor to raise its value again to 10 KΩ or slightly over.

Energising the Bridge

The energising voltage is drawn from the secondary of a step-up transformer of ratio 1 to 5 or so, an ordinary audio-type being suitable. This transformer may be fed from a variety of sources. In the original model two sources were available chosen by the throw of a switch. One was 50 c/s drawn from the heaters of the valves and this, thanks to the sensitiveness of the magic eye and its amplifier, sufficed for nine out of ten of the measurements made with the bridge. For high values of resistance, and low values of inductance and capacity, where the null point on 50 c/s is indistinct, provision was made to use a signal at about 1,000 c/s generated by a multivibrator circuit (described by the writer in PRACTICAL WIRELESS for May last) and injected at the terminals shown on the panel. Alternative forms of 1,000 c/s generators which could be incorporated in the bridge are suggested in Fig. 3—the component values given should be regarded as experimental as the writer has not found it necessary to try either in place of the existing sources. A 1,000 Ω 3-watt resistor is shown in series with the secondary of the transformer.

Without it the bridge could pass during the measurement of a low impedance a current large enough to damage the component or the transformer. The resistor limits the current to a safe value, but when a high impedance is being measured it has relatively little effect, and nearly the whole voltage across the secondary is available to produce a sharp null point.

Construction

It will be seen from the theoretical diagram that one of the "x" terminals is at earth potential. This is a useful feature since it means that components earthed to a chassis can be tested without isolating them completely from it. But it also implies that the whole of the variable arm of the bridge VRI is at a different potential and therefore certain precautions must be taken to avoid hand-capacity effects. First, the chassis and the panel upon which the bridge is built should be of metal and connected to the earth line of the power unit, that is usually to the centre tap of the mains transformer. Secondly, VRI should not be fixed to the panel but to a bracket at the rear of the chassis and connected to the dial by a flexible coupling and a rod of insulating material. Thirdly, since the final adjustment of the bridge will be made with the left hand upon VRI (if the layout suggested in Fig. 2 is adopted), the "x" terminals

should be placed at the opposite end of the chassis. Otherwise the layout of the instrument can be varied within wide limits to suit the constructor's own requirements and material. The single index common to the range dial and the multiplier dial should, of course, be retained. The range and multiplier knobs should be of the flat type so that a circular piece of white cardboard can be fixed to the skirt of each to carry the graduations. They should also be capable of being adjusted on the spindles so that the flat portions are the same distance from the panel. This is shown in Fig. 4 as is the plan of the index. The latter can

(Continued on page 421)

TABLE I
Range Switch Positions

1, 2 & 3			4, 5, 6 & 7			8, 9, 10 & 11		
Wheatstone Bridge			Capacity Bridge			Hayes Bridge		
Range 1	10-1000Ω		10-1000pF			10-1000μH		
2	1K-100KΩ		0.01-0.1μF			1-100mH		
3	100KΩ-10MΩ		0.1-10μF			0.1-10H		
4	10MΩ		10-1000pF			1-100H		

80 ohm COAX
CABLE
STANDARD 1/4" diam.
Polythene insulated
NOT EX GOV.
10d. per yd.

RESISTORS.—All Values. 1 w., 40.; 1 w., 6d.; 1 w., 80.; 2 w., 1/-.
WIRE-WOUND RESISTORS. Best makes Miniature Ceramic Type.—5 w., 15 ohm to 4 K., 1/9; 10 w., 20 ohm. to 6 K., 2/3; 15 w., 30 ohm. to 10 K., 2/9; 5 w. Vitreous, 12 K. to 25 K., 9-.

W/W POTS.—T.V. Type Pre-Set. Miniature. Potted knob is knurled and slotted. 200, 500 ohm., 1 K., 2 K., 2.5 K., 5 K., 10 K., 15 K., 20 K., 25 K., each 3/-.
COILS.—Weatite "P" type, 2/6 each; Midget—Osmon "Q" type, 3/6 each. All ranges in stock.

O/P. TRANSFORMERS.—Standard pentode, 3/9; Heavy duty 70 ma., 4/6; Universal tapped primary, 4/9; Midget 354, etc., 3/8; 1/2" chokes 10 H. 70 ma., 4/6; Midget inter-valve trans., Ratio 4:1, 4/6.

WIRE ENAMELLED COPPER.—14, 16, 18 s.w.g., 3d. per yd.; 20, 22 s.w.g., 2d. yd.; 24, 26 s.w.g., 1d. yd.; 28 to 32, 1d. yd.; 34 to 40 s.w.g., 1d. yd.

ELECTROLYTICS.—New Stock. 8/400 v. B.E.C. Midget Tub., 2/6. 8/450 v. T.C.C., Small Can, 2/6. 16/450 v. T.C.C., Med. Can, 3/6. 8+8/450 v. B.E.C. Midget Tub., 4/-. 8+16/450 v. B.E.C., Med. Can, 5/-. 16+16/450 v. B.E.C., Med. Can, 5/6. 20/250 v. B.E.P., Ins. Tub., 1/8. 50/50 v. B.E.C., Ins. Tub., 2/-.
1852 REGENSTONE RADIO CHASSIS.—Long, Medium, Short Wave, Superhet. A.C. Mains 200/250 v. Five Mullard Valves ECH42, EF41, EB041, EL41, 6Z40. Reception tested O.K. Some metal corrosion due to fire salvage. Bargain. Price 61 gns., var. 3/6.

NEW BOXED VALVES ALL GUARANTEED

SUMMER SALE PRICES

1R5 .. 9/-	6AM6 .. 10/6	12K8 .. 9/6	EF39 .. 8/6
1R4 .. 9/-	6B46 .. 12/6	12Q7 .. 10/6	6BE6 .. 10/6
1R5 .. 9/-	6K7 .. 6/6	35L6 .. 9/6	EF50 .. 7/6
1T4 .. 9/-	6K8 .. 10/6	3Z24 .. 10/6	6BW6 .. 10/6
3R4 .. 9/6	6L6 .. 10/6	50L6 .. 8/6	EF91 .. 10/6
5V4 .. 9/6	6N7 .. 8/6	807 .. 10/6	EF92 .. 9/6
5Z4 .. 8/9	6Q7 .. 10/6	EA50 .. 2/-	EY31 .. 12/6
6B9 .. 7/6	6R7 .. 10/6	EB34 .. 1/6	EY91 .. 7/6
6C4 .. 7/6	6RN7 .. 11/-	EB91 .. 8/6	KT61 .. 10/6
6P9 .. 8/9	6V6 .. 9/6	EBCC3 .. 9/6	KT69 .. 9/6
6R6 .. 6/6	6X5 .. 9/-	ECL91 .. 7/6	MU12 .. 9/6
6I16 .. 3/6	6U5 (Y63) 9/-	ECL80 .. 12/6	SP41 .. 4/6
6J7 .. 8/-	7K7 .. 9/6	PEH46 .. 7/6	SP61 .. 8/6
6K6 .. 7/8	12K7 .. 10/6	EF36 .. 7/6	X61 .. 10/6

SPECIAL PRICE PER SET :
1R5, 1T4, 1R5, 3R5 32/6
6K8, 6K7, 6Q7, 6V6, 5Z4 40/-
12K8, 12K7, 12Q7, 35Z4, 35L6, 45/-
10EP91 for Pract. Television A.C./D.C. TV 85/-
RP50 Ex New Equip. All tested. 4 for £1.

1852 REGENSTONE RADIO CHASSIS.—Long, Medium, Short Wave, Superhet. A.C. Mains 200/250 v. Five Mullard Valves ECH42, EF41, EB041, EL41, 6Z40. Reception tested O.K. Some metal corrosion due to fire salvage. Bargain. Price 61 gns., var. 3/6.

T.R.S. 307, WHITEHORSE ROAD, 61 GNS. WEST CROYDON.
Telephone: THORnton Heath 1665
Mail Order: 71, Meadvale Road, East Croydon.
Bargain Lists, 3d. Terms C.W.O. or C.O.D. Over £1 post free. P. & P. 6d. extra.

VOLUME CONTROLS
Midget Ediswan type.
All values, long spindles.
guaranteed 1 year.
LESS Sw. S.P. Sw. D.P. Sw.
3/- 4/- 4/9

TRANSFORMERS.—For many years we have manufactured and re-wound exclusively for the trade, research laboratories, etc. These facilities are now being extended to the Radio Constructor. The same high quality in manufacture will still be maintained and all windings are interwelded and impregnated. We use our own Transformer products on all our experimental and service work. We are busy and we only recommend what we use ourselves.

P.P. O/P Trans. to spec. from 15/6. Quality ditto, Stubby Lamps, and low leakage windings from 35/. Williamson Mains Transformer, 47/8. Heater Taps, 6.3 v. 11 amp., 7/8. 350-0-350, 50 ma., 6.3 v. 4 a., 5 v. 2 a., ditto 300-0-300, ditto 250-0-250, 21/. Viewmaster Mains Transformer, Int. 4 type, 35/-. E.H.T. Transformer, 2.5 Kv., 4 v. and 2+2 v., £2/10/0; ditto, 1.75 Kv., £2/5/0. P. & P. extra on Transformers.

* Quotations for specials per return.
M'core solder 60/40, 10 1/2 lb.; 4d. yd; 5in. P.M. Speaker Pleseye, 11/6; T.C. wire 16 to 22 s.w.g. per yd., 3d.; Microphone Transformer, 50 : 1, 2.9 : 8 mfd., 500 v. Dubilier Tubular, 3/-; 16 mfd., 500 v. Dubilier Tubular, 4/-.

BARGAIN CORNER.
Twin Gang, 0005 mfd., 5/6; 2 v. Accumulator 10 A/H, 4/9; 6 v. Vibrator Pack (less vib.), 12/6; 12 v. Vibrator Transformer, 7/6; 1.0. valve holders, Paxolin, doz. 2/6; .002 mfd. 10 Kv. E.H.T., 2/8; Met./Rect. 260 v. 80 ma. (equip.), 6/6.

G2AK This Month's Bargains G2AK

MINI FOUR. All parts from stock. Ready Drilled Chassis Kit, 7/6. P. & P. 1/-.
MIDGET SPEAKERS, W.B., 2 1/2 in., 18/6; Philips, 3 in., 15/-; W.B., 5 in., 16/-; Elac, 6 1/2 in., 17/6. P. & P., 1/-.
TEST PRODS. for test meters. Red and black, 4/6 pair.
ELAC FOCUS UNITS, for triode and tetrode tubes. P.M. type; List, 30/- . Our price, 20/-, post free.
SPECIAL TRANSFORMER OFFER. Varley or Woden, 0-250 Tapped Primary. 350/350 80 mA. 4v. 2.5 A.C.T. 4v. 5 A.C.T., 17/6 each. P. & P., 1/6. Limited Quantity.
SELENIUM RECTIFIERS, 250 v. 60 ma. D.C. output. New, 7/6 each.
MORSE PRACTICE SETS, with double-action buzzer, output for 'phones excellent key; require only 4 1/2 v. battery. As new, 7/6. P. & P., 1/-.
MIDGET OUTPUT TRANSFORMERS for personal portables, 6/- . Standard pen., 5/6. Mike trans. for M.C. mikes, 2/-; for carbon, 1/3 each.
XTAL DIODES, 3/9 each. Germanium diodes, 4/6 each.
POTENTIOMETERS. Carbon, 50 k., 100 k., 1 meg, and 2 meg., 1/6 each. 500 ohm H.D. toroidal, 3/6 each. 50 K. W.W. Pre-Set Type, 2/- each. 20 K. W.W. Pre-Set, 1/- ea.
TWIN FEEDER. 300 ohm H.D. Twin, 5d. yd. Standard K25 300 ohm., 9d. yd. K24 150 ohm, 9d. yd. Coax. T.V. cable, 1 in., 1/3 yd. Packing and postage on cables, 1/6.
SPECIAL VALVE OFFER. Kit of 4 midget 1.4 v. valves, 1' each 1R5, 1R5, 1T4 and IS4, 35/- or 9/6 each, separately. Postage free on all orders over £1 except where specifically stated. **PLEASE PRINT YOUR NAME AND ADDRESS.**

CHAS. H. YOUNG, G2AK
All callers to 110 Dale End, Birmingham CENTRAL. 1635
Mail orders to 102 Holloway Head, Birmingham MIDLAND 3254

faithful reproduction
from 50 c/s to 10 Kc/s at 7 1/2 in/sec using



High-quality recorder reproducers demand high-quality tape to produce results that will satisfy the discriminating listener.

"SCOTCH BOY" MAGNETIC TAPE HAS:

- High, uniform sensitivity
- High fidelity at low speeds
- High signal/noise ratio
- Medium coercivity, easy erasure
- Low distortion and transfer
- Special cellulose acetate base giving strength and durability.

in 1200', 600', 300' reels and other sizes.

If you want advice on any tape-recording problem, our entire technical knowledge is at your disposal.

MINNESOTA MINING & MANUFACTURING Co. Ltd
167 Strand, London, W.C.2. Telephone: TEMple Bar 6363

TELEVISION CAN BE YOURS FOR £7

We offer extended payments on two alternative sets :-

P.T. ARGUS. This was described in three recent issues of "Practical Television" and we have had good reports about the quality of reception. This Televisor uses the Government surplus tube Type VCR97 which is now firmly established in the domestic T.V. field. The total price of all components and tube is approximately £20 (list on request) or if you prefer send only £7 deposit, the balance can be spread over 12 months.

VIEWMASTER. This set we need not describe, the name being almost a household word, the total cost depends largely on the type of tube used and as from time to time we have perfect tubes to offer at half current price due to the fact that they have had slight use, we suggest that you leave the purchase of the tube until last.

The total cost of the Viewmaster is £40-£45 depending upon the tube, or if you prefer send only £12 deposit, the balance can be spread over 12 months. If you would rather study the data then send only 2/6 for P.T. Argus or 7/6 for Viewmaster, we are quite willing to refund your cash if you return the data within 7 days.

Yours for £4 17s. 6d.

COMMUNICATIONS RECEIVER R.1155

We have just bought a new consignment of these and can guarantee them to be absolutely unused (not just in re-cracked cases).

This set, as most will know, is considered to be one of the finest communications receivers available today. The frequency range is 75 kc/s to 18 Mc/s. It is complete with 10 valves and is fitted in a black metal case. Made for the R.A.F. so obviously a robust receiver which will give years of service. The price is £14 10s. 0d. or will be sent against deposit of £4 17s. 6d. and balance over 12 months. If you cannot call to collect please include an additional 10/- to cover cost of transit and carriage. This is partly returnable to you if and when you return the transit case.

MAINS POWER PACK FOR R.1155

With Pentode output stage. Plugs into socket on receiver so no internal modifications are required. Price, £5 10s. 0d. complete with 8in. speaker, ready to work, carriage 3/6 extra.

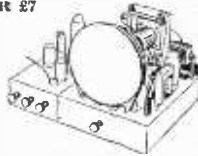

MAGNETIC TAPE RECORDER Yours for £10 10s. 0d.

Tape Deck. Fitted with 3 motors giving fast rewind-forward run and no friction. High fidelity record play back giving approximately 1 hour playing from standard 1,200ft. tape. Additional reels of tape, 35/- each.

Amplifier. High gain enables recording to be made from microphone, pick-up or loudspeaker. Separate bass and treble lift controls.

Cabinet. Portable is rexine covered; table model is polished walnut.

Instruction Booklet. Shows in close detail exactly how to assemble and operate the recorder, is free with kit or available separately at 5/- (credited if you buy kit or completed recorder). Price. Complete kit of parts including 6 B.V.A. valve, reel of best tape, loudspeaker and cabinet (state whether portable or table model required). £31 0s. 0d. or £10 10s. 0d. deposit and balance over 12 months. If required we will assemble and test for £4 extra. Suitable crystal hand table microphone £1 15s. 0d. extra.



THERMOSTATS

All thermostats are fitted with heavy silver contacts and can be adjusted to operate between 30 deg. F. and 300 deg. F. suitable for use with aquariums, electric blankets, space heaters, greenhouse heaters, etc., etc. 1 amp. 250 v., 3/6 (as illustrated); 2 amp. 250 v., 5/6; 5 amp. 250 v., 14/6. Notes.—5 amp. model is fitted with patent arcing device and the 2 amp. model is a quick make and break type. All ratings for A.C.; for D.C. divide by 6.

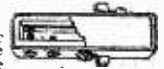

Crystal Set

Long and medium wave, uses latest crystal valve, good results without batteries, or mains. Price 16/6 plus 1/6 post.

Crystal Set to Build Yourself Our little sets owe their excellent performance to the latest type of crystal valve, you can make the rest with our free blueprint.



WINDMILL HILL, RUISLIP MANOR, MIDD. and at 152-153, FLEET STREET, E.C.4.

PRECISION EQUIPMENT

★ FREE 84-PAGE BROCHURE



This free brochure describes the Courses of Training offered by E.M.I. Institutes — the only Postal College which is part of a world-famous Industrial Organisation.

- Aeronautical Engineering • Motor Engineering • Draughtsmanship • Elect. Engineering • Production Engineering • Management • Languages • Refrigeration Engineering • Civil Service • General Certificate of Education • Radio, Television and Electronics • University Training • Mathematics • Mechanical Engineering • Heating & Ventilation Engineering • Public Speaking • Police • Telecommunications, etc. etc.

Special Courses for A.M.I.Mech.E., A. M. I. C. E., A. M. I. P. E., A.M.Brit.I.R.E., A.F.R.Ae.S., City & Guilds Exams., etc.

POST NOW

This coupon entitles you to a FREE copy of "Successful Careers".
Post to E.M.I. Institutes, Dept. 32,
43 Grove Park Road, Chiswick, London, W.4

EMI INSTITUTES
associated with
MARGONIPHONE COLUMBIA & H. M. V.

COURSES FROM £1 PER MONTH

Name

Address

IC9

(Continued from page 418)

be made from Perspex, rectangular in shape and provided with four countersunk screw holes for fixing to the panel. The index mark is a straight scratch in the upper surface of the Perspex filled in with a trace of black enamel. When the index is correctly set on the panel the index mark should lie on the straight line joining the spindles of the variable resistances, and these in turn should lie on the horizontal centre line of the panel or on a line parallel to it. Make the chassis of the usual inverted U pattern. Mark out and drill the panel for the controls, the terminals and the magic eye. Then attach it to the chassis. Next mount VRI with its coupling and knob as suggested above. Fit a blank cardboard scale to the knob. Wire up the multiple switch unit, that is the wiring shown inside the dotted line in Fig. 1 and mount it on the panel with its knob and accompanying scale. Lastly, put the index in position. Then before wiring VRI or the switch unit to each other or to any other components calibrate both as follows:—

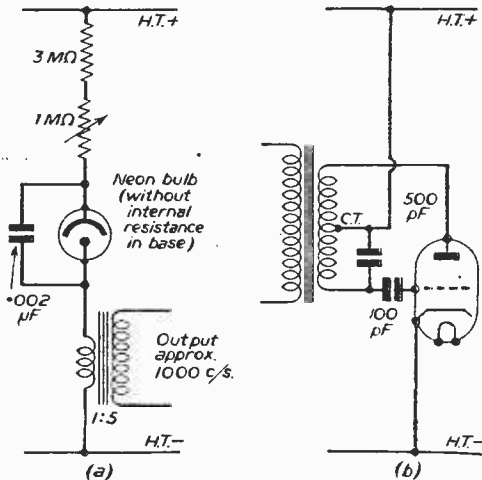

Fig. 3.—Alternative audio sources. (a) Neon oscillator and (b) valve oscillator with a centre-tapped transformer.

Calibration is easy if a second bridge or resistance meter is available. Since the readings of the bridge are all proportional to the resistance of the 10 KΩ variable, calibrate the latter at intervals of 100 ohms and mark these intervals 0, 1, 2, etc., up to 100. There is no objection, of course, to closer calibration, 1.1, 1.2, etc. The calibration should be done, as stated before, while the variable resistance is still unconnected to any other components. Mark on the dial of the range switch opposite the index mark in each of its eleven positions the lowest value of the corresponding range as shown in Table 1. The lowest value is chosen because it is intended to be multiplied by the simple factors shown opposite on the multiplier dial.

Completing the Bridge

Wire in the other components so that the connections between the parts of the bridge proper are very short, particularly those of the 100 pF. standard condenser, the 10 KΩ standard resistor and the leads to the grids of the amplifier and magic eye respec-

tively. Keep the precision components as far as possible from the heat of the valves. Thorough ventilation is essential and this should be kept in mind when choosing a case to house the completed instrument. A sufficient number of ventilation holes should be provided in its sides.

The N.P.I. and the Power Pack

The amplifying portion of the null point indicator may be placed on the chassis but the magic eye itself must be mounted at right angles to the panel. In the original model an escutcheon for the magic eye

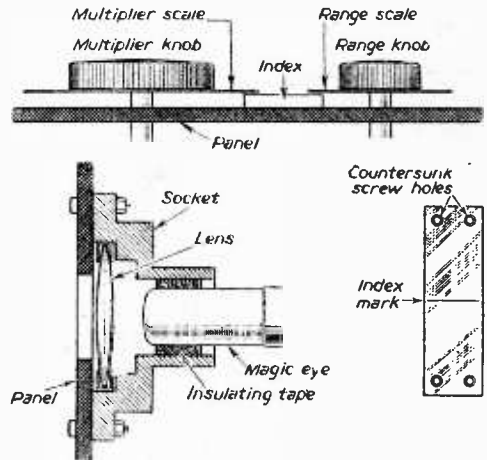

Fig. 4.—Section of escutcheon for magic eye, and indicator mounting details.

was made from a surplus multi-pin socket. The pins were stripped out, leaving a circular tube with a flange carrying conveniently tapped holes to take fixing screws. A lens was fixed in the tubular part by means of washers cut from rubber and cardboard, and the screen end of the magic eye itself was wrapped round with sufficient insulating tape to make a firm push fit in the back of the escutcheon (see Fig. 4). The escutcheon once screwed to the panel provided support, magnification and a neat finish to the indicator. As an alternative to making a U chassis the valves and the audio transformer, from which the energising voltage is drawn, may be mounted on a small sub-chassis set parallel to the panel and spaced from it by distance pieces so that the magic eye lies in its correct position. By this method the wiring can be made very short indeed. An integral power pack may be used but in view of the effect of the heat generated on the precision components a separate unit is desirable, and it is assumed that such is available. The demands of the instrument are very light. The type of leads to which the unknown will be attached depends upon the "x" terminals used, but those ending in crocodile clips are most generally useful. No attempt is made to calibrate the power factor resistance apart from marking "good" at the minimum end and "poor" at the other.

Using the Bridge

To use the bridge set the frequency switch to one of its two positions 50 c/s or 1,000 c/s, and turn

the range switch to the appropriate section R, C or L. Connect the unknown across the "x" terminals, rotate the multiplier dial through its full sweep. If the magic eye opens and closes again adjust the

little experience with the bridge will soon teach the user whether a higher or lower range is required. When the value of the "unknown" is known approximately the correct range can, of course, be chosen

LIST OF COMPONENTS

Valves :	Precision Resistors and Condensers:	Sundries :
1 R.F. Pentode. 6AC7	One each 10 Ω , 1,000 Ω , 10k Ω ,	1 large skirted knob.
1 Magic Eye. Y63	100pF, 0.01 μ F, 1.0 μ F.	1 small skirted knob.
		1 pointer knob.
Switches :		2 valveholders.
1 1p. 2w. key type.	Fixed Resistors and Condensers:	1 neon lamp (without voltage dropping resistor in base).
1 4p. 11w. rotary.	1 5M Ω .	4 insulated terminals.
	2 2M Ω .	2 flying leads terminating in crocodile clips.
Variable Resistors :	1 1M Ω .	Cardboard for panel and dials.
1 10k Ω W/W.	1 200k Ω .	Mains unit supplying 6.3 heater volts and about 250 volts D.C.
1 20k Ω W/W.	1 50k Ω .	Sheet of Perspex.
1 1 M Ω preset.	1 25k Ω .	
	1 1k Ω .	
	1 0.002 μ F.	
	2 0.1 μ F.	
	1 4 μ F or an electrolytic condenser of greater capacity.	

multiplier dial for maximum shadow. The value of the component can now be read off from the dials. If a null point cannot be obtained the neighbouring ranges must be tried in similar fashion. A

at once. If the null point is not sharp adjust the power factor resistance until a more definite indication is obtained. Then read off the resistance, capacity or inductance from the dials.

An Aerial Current and Tuning Indicator

A TRANSMITTING ACCESSORY BY G2VU

THIS device consists of an ordinary screw bulb-holder adapted so that it can be used in the aerial feeder circuit for tuning, and to indicate the actual aerial current in the case of low-power sets.

An insulated silver-tipped spring passes, as shown in the drawing, through a slot in the bottom of the holder, which is attached to a piece of strip brass, and is operated by screwing the bulb in or out,

Bulb Rating

Screw bulbs can be obtained in various ratings, and it is easy to choose one suited to the output of the set and thus obtain an indication of the wattage being dealt with. The centre contacts of the bulbs should be filed down as they are usually oversize.

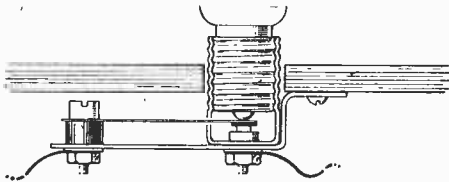

Details of the simple indicator described here.

causing the spring to make contact with a silver pin in the head of the holding screw, thus acting as a switch.

When the bulb is fully screwed in, it is short circuited and a direct metallic circuit is provided for the aerial current. On giving the bulb a quarter turn outwardly the insulated spring follows the bulb and brings it into circuit.

Advantages

Tuning and indicating by bulb has several advantages, apart from saving of cost and space. This holder is arranged for one hole fixing and occupies a space of only 1 1/4 in. by 5/16 in. Two advantages are that the cutting in or out of the bulb does not interrupt the circuit, and if the bulb is burnt out, by screwing it in the circuit is instantly restored.

Stockholm Conference on VHF.

A CONFERENCE to consider the assignment of very high frequencies (ultra short wavelengths) for sound and television broadcasting in Europe, which began in Stockholm on May 28th, has just completed its work (on June 30th). The use of television and very high frequency sound broadcasting on any appreciable scale by European countries is a comparatively recent development, and the Conference, which was convened at the suggestion of the Swedish Administration, was the first of its kind. It was attended by representatives of 31 countries.

The Stockholm Conference has produced an agreement with which are associated three plans for the assignment of frequencies to European broadcasting stations, one for each of these three bands.

In band one (41-68 Mc/s) the Conference accepted the assignments which the United Kingdom has made for the five high-power television stations of the BBC, and for the five low-power stations which are to open in due course. The way in which sound and television broadcasting services will develop in the United Kingdom in bands two (87.5-100 Mc/s) and three (174-216 Mc/s) has yet to be decided.

The Stockholm plans will come into force on July 1st, 1953, and are due to be reviewed not later than July 1st, 1957.



introducing our latest kit

The *Skyway* TAPE RECORDER AND RECORDING AMPLIFIER

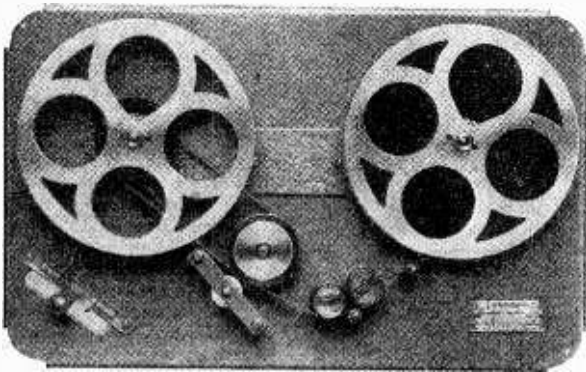

Available as a kit of machined parts ready for assembly or as a complete unit ready for use. Many desirable features are incorporated including 2-speed operation for 3 1/2 in. or 7 1/2 in. per second; Hi-Fi record/playback and R.F. erase heads of the half-track type giving over 2 hours playing time on one reel of tape. Completely automatic operation with ONE-KNOB CONTROL for stop, rewind and forward; instant rewind without unthreading. Ball-bearing capstan, oilite self-lubricating bushes to all other bearings. Attractive blue mottle hammered finish.

**RECORDER UNIT
KIT
PRICE** **18 GNS.**
Less tape and reels.

**COMPLETE
wired and tested
with tape and reels.** **£25**

**De Luxe AMPLIFIER
KIT with 8-stage
wiring diagram.** **14 GNS.**

Illustrated leaflet free on request



U.E.I. CORPN.,

THE A.C. MAINS RL155 COMMUNICATIONS RECEIVER.—This famous Bomber Command Receiver now available complete with power pack, output stage and speaker, ready to operate. Just plug in and receive the world, with a receiver of the £100 class. Wave ranges covered are 18.5-7.5 mcs., 7.5-3.0 mcs., 1,500-600 kcs., 500-200 kcs., 200-75 kcs. Every set is thoroughly tested and checked before despatch, and is BRAND NEW AND UNUSED IN THE MAKER'S TRANSIT CASE. ONLY £16 19s. 6d. complete (carriage, etc., 15.6) OR BRAND NEW RECEIVER ONLY £11 18s. 6d. (carriage 10/6). **POWER PACK, OUTPUT STAGE AND SPEAKER** ready to plug on to any RL155. ONLY 25 10s. (carriage, etc., 5/-). **BUY THE COMPLETE RECEIVING STATION AND SAVE 10/-.** **INDICATOR UNIT TYPE 6.**—Contains 6in. C.R. Tube, VCR97, 4 valves EF50, 1 of EB34 and 1 of EA50. The unit recommended for conversion to the "Wireless World" General Purpose Oscilloscope, full details supplied (or available separately, 1/-). ONLY 79/6 (carriage, etc., 7/6). **MODULATOR TYPE 67.**—Contains fully-smoothed normal A.C. Mains power pack, transformer being 345 v.-0-345 v. at 200 ma., 6.3 v. 5 a., 6.3 v. 250 ma., 5 v. 2 a. Also contains 6 valves SF61, 3 of EA50, 2 of EB34, and 1 of 5Z4. Complete in metal case size 8in. x 8in. x 7in. ONLY 72/6 (carriage, etc., 5/-). **100 MICROAMPS METER.**—21in. Flush Mounting. Widely calibrated scale of 15 divisions marked "Yards" which can be rewritten to suit requirements. These movements are almost unobtainable today, and being BRAND NEW IN MAKER'S CARTONS, are a "snip" at ONLY 39/6. **50 MICROAMPS METER.**—2in. Flush mounting. Another movement which is in short supply and is also BRAND NEW IN MAKER'S CARTON. ONLY 45/-. Also a few 2 1/2in. type available. ONLY 70/-.

POTENTIOMETERS		
Less switch	3/-	
With switch	4/6	
VALVEHOLDERS		
I.O. or M.O.	6d.	
B9G	10d.	
Diode	6d.	
RESISTORS		
1w.	4d.	
1w.	5d.	
1w.	6d.	
2w.	9d.	
15w., 2.5k.	2/-	
CONDENSERS		
Mica and Silver Mica		
Tubulars—		
1mf.	6d.	
.01mf.	9d.	
.05mf.	6d.	
.005mf.	2d.	
.5mf.	9d.	
25mf. 25v.	2/6	
30mf. 12v.	4/6	
1mf. 2.5kv.	1/6	
ELECTROLYTICS		
5mf. 450v.	2/6	
8 x 8mf. 450v.	4/9	
16 x 16 mf. 450v.	7/6	
25mf. 25v.	1/8	
30mf. 12v.	1/6	
P.M. SPEAKERS (With Transformer)		
5in. Goodmans	15/-	
8in. Goodmans	17/6	
P.M. SPEAKERS (Less Transformer)		
5in. Bola	16/6	
6in. Plessey	14/6	
10in. Goodmans	22/6	
(Postage 1/6 per speaker.)		
PENTODE OUTPUT TRANSFORMER		
Goodmans	5/6	
CHOKE		
20H. 80ma.	9/-	
30H. 100ma.	12/6	
5H. 200ma.	6/-	
(Postage 1/- per choke.)		

THE RADIO CORNER, 138, Gray's Inn Road, London, W.C.1 (Phone TERminus 7937)

TRANSFORMERS.—Manufactured to our specification, and fully guaranteed. Normal Primaries. 425 v.-0-425 v. 200 ma., 6.3 v. 6 a., 6.3 v. 8 a., 5 v. 3 a., 0-2-4-6.3 v. 3 a. ONLY 72/6. 425 v.-0-425 v. 200 ma., 6.3 v. 4 a., 6.3 v. 4 a., 5 v. 3 a. ONLY 50/- 350 v.-0-350 v. 160 ma., 6.3 v. 6 a., 6.3 v. 3 a., 5 v. 3 a. ONLY 42/6. 250 v.-0-250 v. 100 ma., 6.3 v. 6 a., 5 v. 3 a., upright mounting. Universal Mounting 350 v.-0-350 v. 80 ma., 0-4-6.3 v. 4 a., 0-4-5 v. 2 a. ONLY 18/6. 250-0-250 v. 80 ma., 0-4-6.3 v. 4 a., 0-4-5 v. 2 a., ONLY 18/6. The following are upright mounting. EHT for VCR97 Tube, 2,500 v. 5 ma., 2v.-0-2 v. 1.1 a., 2v.-0-2 v. 2 a. ONLY 37/6. * EHT 5,500 v. 5 ma., 2 v. 1 a., 2v. 1 a. ONLY 72/6. EHT 7,000 v. 5 ma., 4 v. 1 a. ONLY 82/6.

PLEASE ADD 1/6 PER TRANSFORMER POSTAGE

TRANSFORMER, for use on trains, models, etc., giving outputs of 3 v., 4 v., 5 v., 6 v., 8 v., 9 v., 10 v., 12 v., 15 v., 18 v., 20 v., 24 v., 30 v., at 2 amps., from normal mains input. ONLY 17/6 (postage 1/-).

TRANSFORMERS.—Ex W.D. and Admiralty, built to more than 50% safety factor, with normal A.C. Mains Primaries. All Brand New and Unused. 300 v.-0-300 v. 200 ma., 5 v. 3 a., 6.3 v. 5 a. C.T., 20 v. 750 ma., 70 v. 100 ma. Weight 12lb. ONLY 42/6 (postage, etc., 2/6). 330 v. 0-330 v. 100 ma., 4 v. 3 a. Weight 7 lb. ONLY 22/6 (postage, 1/6). I.T. 5 v.-0-5 v. 5 a., 5 v.-0-5 v. 5 a., 5 v.-0-5 v. 5 a. By using combination of windings will give various voltages at high current. Weight 11 lb. ONLY 35/- (postage etc., 2/6). I.T. 6.3 v. 7.7 a., 4.2 v. 2.5 a., 4 v. 1 a. ONLY 19/6 (postage, 1/6). EHT 1,400 v. 2 ma., 500 v. 10 ma., 300 v. 10 ma., 2 v. 1.5 a. ONLY 21/- (postage, 1/6).

Cash with order, please, and print name and address clearly.

Open until 1 p.m. Saturdays, we are 2 mins. from High Holborn (Chancery Lane Station), 5 mins. by bus from King's Cross.



TALK on your Own Radio
SING
RADIOMICROPHONE

post 1/6

12/6

connects to Radio pick-up
or Gram Sockets. Ideal
Baby Alarm or House Phone

**EASY TERMS
CATALOGUE**
5d. stamps.

ELECTROLYTIC CONDENSERS (Brand New 1952 Stock). Postage 6d.

Wire Ends	Cans
2m d. 450 v. .. 2/-	8 x 8 m/d. 500 v. 3/6
4 .. 450 v. .. 2/6	8 x 16 .. 500 v. 4/0
8 .. 500 v. .. 2/6	16 x 16 .. 500 v. 5/0
16 .. 500 v. .. 2/8	16 x 24 .. 350 v. 5/9
25 .. 25 v. .. 1/3	16 x 32 .. 274 v. 6/6
50 .. 50 v. .. 1/2-	16 m/d. Govt. Surplus 175 v. each 1/-

SERVICE SHEETS, the one you require enclosed if available in a dozen our choice, 10/6.

CONDENSER TESTERS AND RECTIFIER UNITS Plug straight into A.C. mains, 200/240 v., and is indispensable for examination of condensers. Very slight and intermittent leakages which cannot be discovered by conventional instruments can be traced by this unit. Complete 59/6. Post 1/-, supplies are becoming limited.

A.C./D.C. NEON TESTER, TYPE 400. This new model is specially designed for one-pole tests on mains, incorporating a highly sensitive neon tube—striking voltage 100/500 v. A.C./D.C. Also suitable for indicating polarity on D.C. current, when the glow of the lower electrode will indicate the negative pole, 11/3. Post 6d.

TAYLOR 7-range multimeters, A.C./D.C., 0-6-30-150-300 v. 0-20 mfd.—300 m/A. 21-tampers precision M.I. movement, 50/-, Post 1/4.

TAYLOR ON EASY TERMS. KARY TERMS up to 10 months—and very near Cash Price on all TAYLOR METERS.

ADCOLA 3/16in. DIA. BIT SOLDERING INSTRUMENT. Miniature type to meet every requirement for Radio, Television, etc., 22/6, post 1/-.

HYDROMETERS Unbreakable, all plastic correct for 60° F., 7/8.

★ —If yours is a (RARE) valve problem **BULLS** are the people most likely to solve it.



"DEMOBBER VALVES"

Manual 2/3
Post free

Give us Equivalents of British and American Service and Cross Reference of Commercial Types with an Appendix of B.V.A. Equivalents, and comprehensive Price List. We have still Valves left at our **OLD-BUDGET** rates which are actually sold at the old price.

EXPORT

to all parts of the Commonwealth and beyond—safely packed, fully insured (no C.O.D.) and free of tax. Just a few of so many:

1G6, 5/-; 1R5, 11/6; 3Q5, 5/-; 6AB7, VT176, 5/-; 6AC7, VT112 18/2, 8/6; 6B8, 9/6; 6C4, 8/6; 6SJ7, 10/6; 6SN7, 12/3; 7B3, 5/-; 215S0, 6/-; 934, 5/-; 9002, 7/8; AC8P3, 11/6; AEF3, 0/2, 8/-; AT4, 5/-; RF6, 12/6; FC13, 14/-; HL3C, 10/6; HL23DD, 9/6; HL4DD, 12/6; KT263, 7/8; LP2, 7/-; M8Pen, 7/8; Pen30C, 15/-; Pen46, 10/-; TH221, 10/-; VR105, 15/-; VR150, 15/-; VU111, 7/-; Y83, 9/-, Post 9d.

(Kindly mark envelope PW9.)

RADIO BULLS VALVES
246, HIGH ST. STRATFORD AWM

AMERICAN

Type, British Made
A.C. ELECTRIC PAINT SPRAYER

Just plug in & spray. Easier than a brush—twice as fast. Post 2/-

AMPLION TEST METER. 1,800 ohm per volt on all D.C. and A.C. ranges, 10 v., 100 v., and 500 v. D.C. and A.C., 50 mA and 500 mA D.C. Resistance up to 200,000 ohm (3,000 ohm centres scale), with self-contained battery, 5,000 volt range with a separate H.T. test-prpd (9/6 extra). Supplied with test prods. Multi-colour scale easily readable, 25.

ROD ANTENNAS. 1-foot sections, interlocking and extending, copper plated steel, 2/8 dozen.

RESISTOR COLOUR CODE INDICATORS. accurate, disc type, 1/3.

SPEAKER MATCHING TRANSFORMERS. Ex-Govt. Surplus guaranteed, 2/-, post 6d.

MORSE BUZZER OUTFITS. Consisting of a buzzer, a Morse key and a battery compartment, all mounted on a polished baseboard. All parts high grade ex-Air Ministry. An excellent gift for a boy. 6/-, post free.

B.T.H. Germanium Crystal Diodes. Sale Price 3/-, Post 6d.

JUNERO PATENT MULTI-PURPOSE TOOL REDUCED

It punches, bends, shears and threads. Specially designed for Model Making, Metal Working and Home Repairs. (Formerly 20/-) now 10/-.



With "Nakro" slide gauge (formerly 27/8), now 17/6. On AP! PROVAL on week. Refund Guaranteed.

NOW 10/- TAX FREE
Post 1/6.

DUAL RANGE POCKET -VOLTMETER-

0-12 v., 0-250 v. A.C./D.C.

Robustly constructed in Black Lacquered Brass Case. This accurate and well-finished instrument has many uses in the workshop and the home. The Dual Range makes possible the accurate testing of Car, and all L.T. and H.T. Batteries, and house and workshop wiring. The moving Iron System permits considerable overload without damage to the instrument. Particular attention has been paid to Scale Clarity.

DIAMETER 2ins. DEPTH 1in. THE TECHNICAL SERVICES CO. Sherbland Works, Banstead, Surrey.



Price 19/- each. Plus postage and packing 1/-.

WALTON'S OF WOLVERHAMPTON

Super Sensitive High Speed RELAYS 7/6 Each Postage 6d.
Miniature Intervalve TRANSFORMER 3/6 6d.
Plastic MAP CASES, 14in. x 10 1/2in. 3/6 1/-
60v. Standard H.T. BATTERIES 6/- 1/6
10in. ROLA P.M. Extension SPEAKER 25/- Each .. 1/-
8in. TELEDUCTOR P.M. Extension SPEAKER 17/6 1/-
8in. TELEDUCTOR P.M. Extension SPEAKER (with transformer) 19/6 .. 1/-
SPECIAL 8+3+3 mfd. ELECTROLYTIC, 550v. D.C. working (only supplied with other goods), 1/6 each.
TELEVISION CHASSIS, contains 6 Octol, 8 B9C, 3B7G Valve Holders, 6 Tag Panels and metal chassis 16in. x 12in. BRAND NEW and unwired, 10/6 each. Postage 1/6.
Boxes of NUTS, BOLTS & WASHERS, mainly B.A. sizes. each box contains approx. 1,000 items, 3/6. Post 1/-.
Boxes of RIVETS, mainly all, various lengths, 1/16in. to 1in. dia. approx. 1,000 items, 3/6, Post 1/-.
METERS—Centre Reading—75-0-75 Microamps, plain scale Brand new. Only 10/6 each, Postage 6d.
Send s.a.c. and 3d. in stamps for our latest general list.

WALTON'S WIRELESS STORES, 48, Stafford Street, WOLVERHAMPTON

★ A New Receiver for the Home Constructor ★
THE "TWIN" ONE VALVE POCKET RECEIVER

This interesting circuit is designed around the famous "twin" valve now available as a British midget type operating from midget dry batteries. The receiver requires no aerial, earth, or external power supplies, the batteries being entirely self-contained.

As a result of the use of midget components, and the elimination of tuning coils, the set when not in use slips easily into the jacket pocket.

This receiver can be used anywhere, indoors or out, giving powerful headphone reception of many stations on the medium waveband. Full instructions, Circuit, Point-to-Point Wiring Diagram and Component List.

Price 3/3, post free.
SWIFT RADIO (W), 137, COTHAM BROW, BRISTOL, 6
Orders by post only.

CABINETS

Owing to over-production these slightly factory soiled figured Walnut Radio Cabinets can be offered at a bargain price. Manufactured for £3.17.5.

Our price 35/- Incl. P.T.

Can be bought singly or in quantities, and can be adapted for all Mains or Battery units. Post and packing 2/- each, 12 or over, carriage paid.

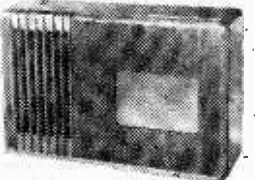

Interior size
19 1/2 x 12 1/2 x 6 1/2 in.

CARLTON CABINET WORKS (LONDON) LTD.

234, High Street, Stratford, E.15
Telephone: MARYLAND 2987

A Cheap Wattmeter

MAKING A SIMPLE CURRENT RECORDER FROM SURPLUS EQUIPMENT

By J. McGrail

OBTAIN an A.C. electric light meter (they can be bought for 10s. upwards) and, having removed it from its iron case, dismantle it completely except for the coil "K."

Separate very carefully the aluminium disc and its spindle. Drill the disc to take the 4 B.A. rod "A" (which I made $\frac{3}{16}$ in. long). The needles "B" should be a tight fit in the 4 B.A. rod. Clamp the disc between the nuts "C," leaving about $\frac{1}{16}$ in. clear at one end of the rod "A." Next drill nut "D" to take wire "G." (I used 18 gauge, shaped as illustrated.) Obtain the mainspring from a small wrist-watch—one can be bought for 1s. if necessary—and solder its inner end to the rod "A" where the $\frac{3}{16}$ in. was left. Thread nut "D" (with "G" fitted in hole x) on to "A" close to "C," and follow with "E."

Do not tighten "E" yet. The original coils "L" were too thick and insensitive, and I replaced them by two coils of 20 turns each of 22 gauge. I used 14 gauge copper wire to mount the pivots "F" and to anchor the outer end of the spring. One length was held under screw "S" and the free end was made into a loop and "F¹" was soldered to it. The second was held under screw "W" and "F²" was soldered in the same way.

Assembly

The aluminium disc was dropped between the iron cores of the coils "K" and "L" and the wire holding the pivots (which had already been approximately shaped) was carefully closed to hold the disc free from obstruction. The third piece of 14 gauge wire was held under screw "T" and its free end brought up to the outer end of the spring and soldered. Having got this far, the disc should swing for some time before finally coming to rest. If it doesn't the use of the 14 gauge wire will become apparent as this can be moved in any direction with the aid of a pair of pliers. The nut "D" must now

be turned so that "G" almost touches the support of "F¹" and the lock-nut "E" tightened.

The Case

I made a wooden box 6 in. x 6 in. x 8 in. and drilled a $\frac{3}{8}$ in. hole in the centre of one end. Then I placed

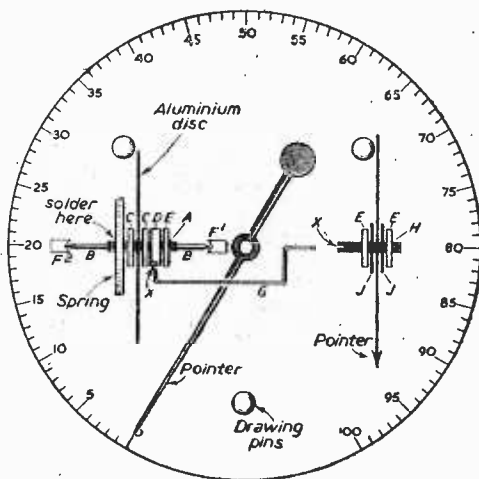

Fig. 1.—Details of the dial and pointer mounting.

the meter in the box so that the 6 B.A. rod "H" (previously fixed to "G" at x) protruded by about $\frac{1}{16}$ in. Next I cut and marked a white cardboard disc and fixed it to the end of the box by three drawing-

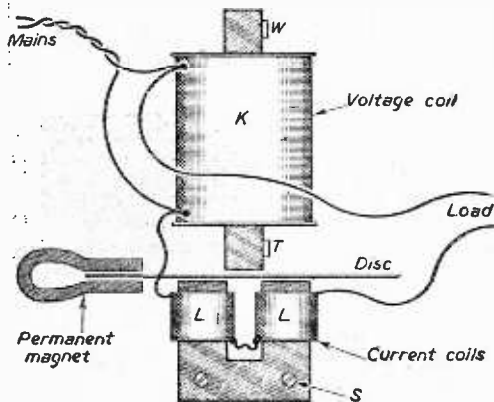

Fig. 2.—General assembly and circuit details.

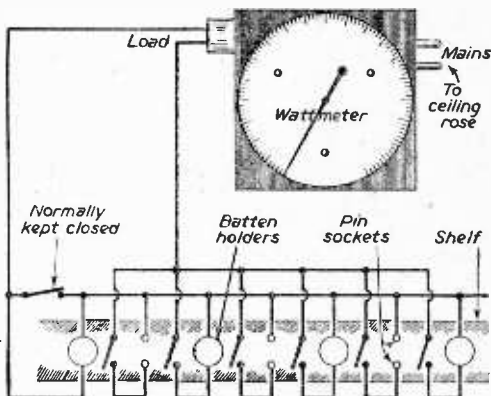

Fig. 3.—Typical workshop or experimental bench arrangement.

pins, also a pointer as shown. This latter was placed on "H" and clamped between "E" and "J," pointing to 0 on the dial. The coils "L" should be wired as shown and if the pointer tries to move the wrong way the connections for "L" must be reversed. It is necessary, when re-assembling, to replace the permanent magnet.

Packing may be necessary to raise the meter so that "H" comes opposite the $\frac{3}{8}$ in. hole in the box. The dial diameter is 6 in. It may be helpful to solder "G" at x and also where the needles enter "A." I marked my meter dial "0 to 100" in black and calibrated (in red) by means of lamps of various wattages.

In order to take full advantages of the meter I have screwed a 5-amp. pin socket on the load side of the box and a pin plug on the input side. Under the shelf on which the meter stands I have screwed seven lamp and pin sockets with their respective switches. Six of these are in shunt and one in series with the rest. They are connected as shown. The series socket is used when I am doubtful of the apparatus I am testing, and is normally shorted out.

Dunsfold Airfield

THE Hawker Aircraft Co., Ltd., who recently took over Dunsfold Airfield, near Guildford, have now completed a new control tower which has been equipped with some of the latest radio and navigational aid equipment, including two V.H.F. D/F installations designed and manufactured by Marconi's Wireless Telegraph Co., Ltd.

The facilities provided for the controller are three V.H.F. channels for communication with aircraft, with automatic D/F on two of them, one V.H.F. channel for contact with the fire appliance, and telephonic communication with selected people on the airfield, together with other necessary authorities in addition to the normal airfield exchange. Provision has been made for a further V.H.F. channel to be fitted at a later date.

The "heart" of the installation is an air traffic control desk, which has been especially designed by International Aeradio, Ltd., to fulfil the requirements of the controller. From the panel in front of him he can determine the local meteorological conditions, as a barometer, wind speed and wind direction indicators, together with a clock, are fitted in the control escutcheon. The heads for driving the wind speed and wind direction indicators are mounted on the roof of the tower. The two escutcheons, on either side of the meteorological one, house loudspeakers to which the receivers on the radio channels are connected, and to identify the channels, close to his left-hand, the controller has four luminous indicators, on the caps of which are engraved the frequencies. On reception a lamp inside the indicator is illuminated showing which channel is calling, whilst to transmit the controller merely depresses the indicator and speaks into the microphone. A fifth indicator gives broadcast facilities which can be used in the event of an emergency. No volume controls are available on the desk, as a special amplifier is fitted between the receiver and loudspeaker which gives a constant output irrespective of the input. The output is set to the required level during installation and thereafter it is not touched. The controller has, therefore, the minimum number of controls for the radio side of his work.

A 100 w. lamp is normally kept in this holder. Shunts across the "load" would enable the meter to be used for anything higher than 5 amps.

MATERIALS REQUIRED

- A. 4 B.A. screwed rod drilled $\frac{1}{8}$ in. at each end to take gram. needles "B."
- B. Gramophone needles.
- C. Thin 4 B.A. nuts.
- D. Thicker 4 B.A. nut drilled at x to take "G."
- E. 4 and 6 B.A. locking nuts.
- F. Pivots (from balance of old clock or M/a. meter).
- G. Copper wire shaped to bring "H" in line with "B" and of a gauge to fit x.
- H. 6 B.A. screwed rod drilled to take "G."
- J. 6 B.A. washers.

The screwed rods can be any length but the aim is lightness.

News from the Clubs

ECCLES & DISTRICT RADIO SOCIETY (G3GX1)

Hon. Sec.: G. Gray, 2, Egerton Road, Monton Green, Eccles, nr. Manchester.

THE club continues to meet weekly on Mondays at 7.30 p.m. at Eccles House Club, Abbey Grove, Eccles, and a cordial invitation is extended to any interested radio-enthusiast to come along to the meetings.

Full workshop facilities are now available, also access to test gear at nearby premises on a Wednesday night.

Arrangements are being made for members to visit Holme Moss television station in the near future.

LEICESTER RADIO SOCIETY

Hon. Sec.: A. L. Mitthorpe (G2FMO), 3, Winster Drive, Thurmaston, nr. Leicester.

AT the meeting held in the clubroom on July 7th, two short lectures were given, one on D/F equipment with practical demonstrations by P. Simpson (G3GGK), and the other on 150-watt transmitters by G8RY. The next important event of the society will be a D/F day on August 30th, and full details of this will be given at the meeting on August 18th.

On September 1st the "Ediswan Cathode-ray Tube" lecture will be given by C. L. Wright, B.Sc.(Eng.), and on October 6th H. Turner (G8VN) will give his lecture and demonstration of "Modern Cinema Sound Recording Equipment."

The society meet every first and third Monday every month, and meetings are held in the clubroom of the Holly Bush Hotel, Belgrave Gate, Leicester, at 7.30 p.m.

Further details of membership can be obtained from the Hon. Secretary.

THE WEST MIDDLESEX RADIO CLUB

Hon. Sec.: P. W. Smith, 121, Richmond Avenue, Hillingdon, Middx.

THE West Middlesex Radio Club meets on the second and fourth Wednesdays of each month at the Labour Hall, Southall Broadway, visitors being welcome.

August meetings are: Wed., 13th: Recorded talks. "The Ether" and "The Ionosphere," followed by a discussion; Wed., 27th: Lecture: "The Principles of Radar."

THE MIDLAND AMATEUR RADIO SOCIETY

Hon. Sec.: G. W. C. Smith (G3HDK), 84, Woodlands Road, Birmingham, 11.

THE field week-end organised by the above Society held on June 28th-29th was a great success, the weather being perfect, and an enjoyable time was had by all. A total of 20 countries were worked.

Following usual practice, a general meeting of the Society will not be held during the month of August.

THE ROCHDALE RADIO AND TELEVISION SOCIETY

Hon. Sec.: J. Riley, 1, Darley Bank, Britannia, Bacup.

THE society have obtained premises for use as a clubroom and all activities this month are concerned with decoration. Meetings are on Friday evenings at 7.45 p.m. at the clubroom, 1, Law Street, Sudden, Rochdale.

CLYDESDALE

Bargains in Ex-Service Radio and Electronic Equipment



**A.C. MAINS 200/250 Volts
GRAMOPHONE MOTORS**

Fitted with 9-inch Turntable and mounted on 8-inch metal plate, for crystal pick-up. Mig. special line.
ASK FOR NUMBER 58/6 Each **POST PAID**
H320

CARBON POWER MICROPHONE
In original carton With transformer and leads (made by Tannoy). Requires only a loud-speaker and 12-volt acc. to make a portable P.A. equipment. Power consumption approx. 2 amps. Output 4-5 watts.
ASK FOR NUMBER 45/- **POST PAID**
P/E694



BC825-A TRANSMITTER CHASSIS



Less Valves Packed by stripped val by the B.O.T. but contains many useful parts. R.F. section in good order. Less valves, crystal switch and crystals. Dim., 15 1/2 in. x 7 1/2 in. x 6 in. Separate modulation transformer and choke supplied.
ASK FOR NUMBER 29/6 **CARRIAGE PAID**
P/E752

TRANSMITTER TUNING UNITS
Unused, but externally soiled, cases slightly dented and scratched, diam. 17 1/2 in. x 8 in. approx.
T.U.5B, a few only at 35/-
T.U.6B, T.U.7B, T.U.8B, T.U.9B, T.U.26B. 1st grade at 22/6 each; 2nd grade at 18/6 each.

A.C. MAINS INDUCTION MOTOR

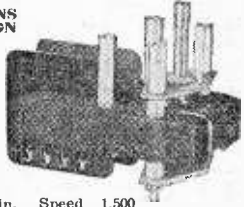

FOR 100-120 or 200-240 volts.
Ideal for models, recorders, etc. 4-hole spinning diameter 1 1/2 in. Length 1 1/2 in. Speed 1,500 r.p.m.
ASK FOR NUMBER 27/6 **POST PAID**
P/H798



ROTARY TRANSFORMER Type 44
Ref.: 10KB/409

input 18 volts. 2.13 amps. Output 450 volts 0.5 amps., with extension spindle both ends. Length 8 1/2 in. x 3 1/2 in. x 3 1/2 in. finish grey.
ASK FOR NUMBER 27/6 **POST PAID**
F/H845

100Kc/s CRYSTAL

Made by Biller, U.S.A. Upright mounting. Dimensions : 1 1/2 in. x 1 1/2 in. x 1 1/2 in. 3-pin plug.
ASK FOR NUMBER 19/6 Each **POST PAID**
F/H795

NEW LIST OF EX-SERVICE ITEMS
No. 8C NOW READY. PRICE, 1/6. Price credited on purchase of 10/- value or over.

FOR INEXPENSIVE TELEVISION INDICATOR UNIT, TYPE 6H
(In Maker's original case)

Containing a VCR97 Cathode Ray Tube, with mu-metal screen, 4VR91's (EF50), 3VR54's (EB34), various w.w. pots, switches, 1 1/2 V. cond., resistors, etc., built in metal chassis to fit into metal box 18 in. x 8 1/2 in. x 7 1/2 in. All controls are brought to front panel beside viewing screen.
ASK FOR NUMBER 89/6 **CARRIAGE PAID**
P/E777

Order direct from:

CLYDESDALE SUPPLY CO., LTD.

2 Bridge Street, Glasgow, C.5.

Phone: SOUTH 2706/9

Visit our Branches in Scotland, England and N. Ireland

HENRY'S

"PYE" 45 M/Cs STRIP. Special purchase of M.O.S. Type 3593 Unit, size 15 1/2 in. x 8 in. x 2 in. Complete with 45 mc/s Pye Strip, 12 Valves, 10 EF50, EB34 and EA50. Volume controls and a host of other Resistors and Condensers. Sound and vision can be incorporated on this chassis with minimum of space. New condition, £5, carriage paid. Circuit supplied.

FOUR SECTION CHASSIS adaptable for the "Argus" Television lay-out, 21/- carr. pd. 182A UNIT. Containing VCR517 6in. C.R. Tube. Mu-metal shield. 3 EF50, 5 SP61, 5U4G, 9W/W Pups. Resistors and Condensers. Tag boards. Tube guaranteed for TV. (No cut-off.) Or suitable for Scope. Brand New, less relay. In original packing case. 79/6, plus 7/6 carriage.

CATHODE RAY TUBES. VCR97 Brand New. Guaranteed Full Picture 40/- carriage 5/-
VCR517. Brand New. Guaranteed Full Picture 40/- 5/-
3BP1. Brand New. Suitable for Scopes 25/- 3/-
9in. ESCUTCHEON. Brown Bakelite. Suitable Plate glass and Mask for 9in. Tube. Price 7/6 each.

★ A COMBINED SIGNAL TRACER AND AUDIO OSCILLATOR ★

An easy-to-build unit that can be used for I.F. and Audio signal tracing, without any switching or tuning. Including variable output oscillator, for amplifier checking. Highly sensitive, responds to signals picked up from an ordinary receiving aerial. The circuit is that of a high-gain 2-stage, resistance-coupled audio frequency amplifier, employing 3 miniature 1.4 valves, with a 3-inch speaker in the output of the Power Amplifier Stage. An added advantage being that as this Unit is "All-Dry" it can be used with safety on A.C. or A.C./D.C. mains and Battery sets. The complete Kit with portable cabinet (size 6in. x 7in. x 6in.) and battery weighs only 4 lbs. We shall be pleased to supply a complete Kit for the construction of the above, right down to the last nut and bolt, including 2-1T4 and 1-1S4 Valves, 3in. Speaker and Portable case and All-Dry Battery for 24/19/6. Concise instructions and circuits supplied. If preferred, circuit and instructions only can be supplied for 1/6. If required this Unit will be assembled and tested for an extra charge of 15/- This is a highly efficient instrument, and a MUST for every radio man.

METAL RECTIFIERS. S.T.C. 300 volt 75 m/a., 6/-; S.T.C. R.M.2. 150 volt 120 m/a., 4/6; G.E.C. 6 volt 1 amp., 4/-; Westinghouse 12 volt 2 1/2 amp., 12/6; S.T.C. 12 volt 3 1/2 amp., 17/6; 12 volt 8 amps., 32/6; E.H.T. Pencil Type, 600 volt 1 m/a., 4/7; E.H.T. Pencil Type, 1,000 volt 1 m/a., 6/-; 2,550 volt 1 m/a., 14/8; 5,150 volt 1 m/a., 26/-; 1 m/a. Meter Rect., 11/6

E.H.T. TRANSFORMER FOR VCR97. Input 230v. Output 2500v., 4v., 2.0-2.45-

E.H.T. TRANSFORMER FOR 5CP1. Input 230v. Output 3,250v. 6.3v. at 0.6 amp., 2.0-2v., 45-

5 K.V. STEWART E.H.T. TRANSFORMER. Input 210/230/250 volts. Output 5kV. and 4v. 1 amp. Insulation volts 6,500. D.C., 79/6

WALKIE-TALKIE TYPE 46. Containing 6 Valves, 2 of VP23, HL23/DD, QP25, TP25, ATP4, 3 I.F.T.'s 1.6 Mc/s. Mike and Intervalve Trans. Aerial Rods, etc. Metal case, size 12in. x 6in. x 4in. In new condition but less transmitting components removed by the M.O.S. Price including carriage, 35/- Less valves 14/-

STROBE UNITS. Brand New, in sealed maker's cartons, these contain SIX EF50's, one 5Z4, five EA50's, one SP61, a host of condensers, resistors, transformers, chokes, relays, switches, seven pots and five smoothing condensers. On two easily separated chassis they measure 6in. x 8 1/2 in. x 7 1/2 in. ONLY 67/6, plus 5/- car.

EX-GOVT. VALVES. The following are Brand New:--
EF50 Red Sylvanian, Original Boxes (U.S.A.) 10 0
EF50 English Types, Original Boxes 8 6
EF50 Ex-Units, Guaranteed 8 0
The following at 8/6 each:--
EP30, EF54, CV68, EF8, EF96, EF99, EK32, EL32, EBC33, 42SP7, 6K7GT, 6J7GT, 6L7GT, 6SK7GT, 6SJ7GT, 6BG6T, 6N7GT, 6J5GT, 6C5GT, 6AC7, 6SA7GT, 6SH7GT, 6D6, 6C6, 6N7, 12SA7GT, 12SK7GT, 12S7GT, 12SQ7GT, 12C.8, 12SR7GT, 12SH7GT, 12A6GT, 14A7GT, 12Q7GT, 7ATGT, 7C7GT, 7H7GT, 7S7GT, 7B6GT, 41MP, 955, 9001, 902, 9003, VU150, 30, 2B7, 929, 12, 12, V41, MS, P6NB, 6S57, KTW62, V570, 7545, 5Z4G, 5Y3G, 6X5GT, 1G6GT.
At 10/-: 6F7, AC6/PEN, MU14, 6AM6, 6V6G, 6V6GT, 5U4G, 6Q7, 6A8G, U52, U19, PX25, 6AG5, 5R4G, EF91, 80. At 11/-: 25Z6GT, 35L6GT, 50L6GT, KT81. At 12/6: 6A7, 6K9G, 6K8GT, KT33C, 43, 6L6G, 1B22, 6AG7, 6SL7GT, 6SN7GT, 6K6, 6J6. At 5/-: VU111, D41, D42, D63, VU133, VU12A, RL18, 6H6, 4D1, VR65, SP61, 954. At 3/6: EB34, VR92, D1.
ALL DRY BATTERY VALVES. 1S5, 1R5, 1T4, 154, 3S4, 3V4, 1L5GT, 1H5, 1N5GT, 3Q5GT, at 10/- or 36/- set of four. At 8/6: 1P22, TP22, TD2A, TP22, VP23, HL23/DD, PEN25, TP25. At 6/-: 21SSG, KT2, PEN220. At 4/-: P2 (Super Power). At 2/6: HL2. At 7/6: HIVAC, XH and XL. At 12/6: 1A7GT. At 15/-: 6AK5.
28 PAGE CATALOGUE ★

★ SEND STAMPS FOR

5 HARROW ROAD, PADDINGTON, LONDON, W.2. TEL: PADDINGTON 1008/9, 0401.

THE HAM'S SHOP

65, DONECALL STREET, BELFAST

DEFINITELY THE CHEAPEST ELECTRICAL AND RADIO SHOP IN THE UNITED KINGDOM.

ROD AERIALS. 12ft. at 5/6. WHY PAY MORE. **MAINS TRANSFORMERS** 250-0-250 6.3 v. and 5 v. at 16/-; 350-0-350 6.3 v. at 17/6; 350-0-350 6.3 v. and 5 v. (RM at 25/-). **METAL BOXES WITH LID.** 5in. x 2 1/2in. x 2in., 1/16 each. (Cannot be repeated.) **ELECTROLYTIC CONDENSERS.** 32 mfd., 3/-; 50 mfd. 50 v., 1/3 and 1/6 each; 8, 16 mfd. 450 v., at 4/6 each; 25 4d. each. **MICA CONDENSERS.** .001 to .0001 6d. each. **RECTIFIERS.** 230 v. 80 m/a., 5/6 each. **RECEIVERS.**—Type 1155, £7 10s. each. **REELS FOR TAPE RECORDERS.** 21- each. **WIRE FOR RECORDERS.** 15/- per reel. (Cannot be repeated.) **TEST OSCILLATORS AND SIGNAL GENERATORS.** 30 to 40 mc/s., £6 each. **ALADDIN FORMERS,** with cores, at 6d. and 9d. **PLUGS AND SOCKETS.** 3-pin, 5 amp., 2/6 each. **SMOOTHING IRON ELEMENTS,** 1/9 each. **TRANS-MITTERS.** 1154, 1216 each, less meters and resistances. **SPEAKER GAUZE.** 1/6 per sq. ft. **TRANSFORMERS.** I.F., 465 kc/s, 10/- per pair; 1.6 meg/s., 7/6 per pair. **CO-AX CABLES.** 1in, 80 ohms, 1/3 per yard. **CHASSIS WITH COMPONENTS.** 7/6 each. **DIALS S.N. ADMIRALTY PATTERN,** 4/6 each. **MOTORS.** 6, 12, 24 v. A.C. and D.C., 12/6 each, suitable for hedge clippers. **TRANSMITTING COIL FORMERS.** 3/6 each. **TRANSMITTING CONDENSERS,** split stators, various caps, 17/6 each. (Cannot be repeated.) **WESTON TEST METERS,** £6 10s. each. (Cost £30 each.) **TRANSMITTER RECEIVER.** Type 1P, £3 10s. each, complete. **RECEIVERS.** A.R.88, £45 (one only). **RECEIVERS, CNY1,** complete with power unit. £5. **TRANSMITTER RECEIVER,** Halicrafter, £20. **TOBE COMMUNICATION RECEIVER.** Less cabinet, £6 10s. **VALVES.** Prices, etc., on application.

PACKING AND CARRIAGE EXTRA. ENQUIRIES PLEASE ENCLOSE S.A.E.
DELIVERIES WITHIN 10 DAYS.
Thousands of other bargains too numerous to mention.
ALWAYS AT YOUR SERVICE.

BSR INDUCTION MOTORS

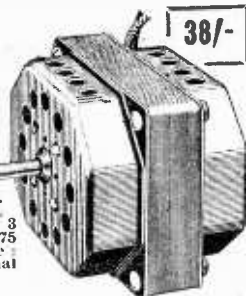

4-POLE MOTOR, FP 10
Fully protected. Negligible external magnetic field. Oil impregnated self-aligning bearings. Silent running. Speed constancy. Voltage: 100/125-200/250 A.C. Consumption at 230 V.: 14 watts. Speed (light): 1,400 R.P.M. Max. and Starting Torque: 3 inch ozs. Shaft dia.: .1875 inches. Weight: 1 1/2 lb. Size: 3 1/2in. x 2 7/8in. x 2 1/2in. External shaft length: 1 inch.

2-POLE MOTORS Models SR1 and SR2

Rugged and highly efficient motors that will stand heavy overloads, and for intermittent ratings are capable of giving up to twice the rated power. These motors are ideal for gramophone motors, fans, motion displays, switch movements, timing mechanisms, wire and tape recorders, etc.

SPECIFICATION: Voltage: 230 A.C. Frequency: 50 cycles (Other voltages and frequencies to order.)

	S.R.1	S.R.2
Consumption (light)	21 watts	17 watts
Speed (light)	2,750 r.p.m.	2,750 r.p.m.
Starting Torque	2.3 inch ozs.	1.7 inch ozs.
Full Load Torque	3.0 inch ozs.	2.0 inch ozs.
Weight	2.31 lbs.	1.7 lbs.
Price	32/-	25/-

Shaft diameter: .1875 inches. Bearings: Self-aligning. Under 30 deg. temperature rise. Vacuum impregnated layer wound coil. **B.S.R SHADED POLE INDUCTION MOTORS, TYPE TP1**
Speed 2,900 r.p.m. * Mains consumption, 10-15 watts. * 200-250 V. 50 c/s. A.C. * Net wt. 1 lb. 22/-



E & G MAIL ORDER SUPPLY CO.

The Radio Centre

33, Tottenham Court Rd., London, W.1.

FREE TO AMBITIOUS ENGINEERS!

This 144-page Book



'ENGINEERING OPPORTUNITIES'

is a highly informative guide to the best-paid Engineering posts. It tells you how you can quickly prepare at home on "NO PASS—NO FEE" terms for a recognised engineering qualification, outlines the widest range of modern Home-Study Courses in all branches of Engineering and explains the benefits of our Employment Dept. If you're earning less than £14 a week you cannot afford to miss reading this unique book. Send for your copy to-day—FREE.

--- FREE COUPON ---
Please send me your FREE 144-page "ENGINEERING OPPORTUNITIES"

NAME
ADDRESS

Subject or Exam. that interests me
British Institute of Engineering Technology,
409B, Shakespear House,
17/19, Stratford Place, London, W.1

Have you sent for your copy?

WHICH IS YOUR PET SUBJECT?

Mechanical Eng.
Electrical Eng.
Civil Engineering
Radio Engineering
Automobile Eng.
Aeronautical Eng.
Production Eng.
Building, Plastics,
Draughtsmanship
Television, etc.

GET SOME LETTERS AFTER YOUR

NAME!
A.M.I.Mech.E.
A.M.I.C.E.
A.M.I.P.E.
A.M.I.M.I.
L.I.O.B.
A.F.R.Ae.S.
B.Sc.
A.M.Brit.I.R.E.
CITY & GUILDS
GEN. CERT.
OF EDUCATION
etc., etc.

"ADCOLA" SOLDERING INSTRUMENTS

Regd. Trade Mark



Regd. Design No. 600302

(British, U.S. and Foreign Patents)

For Wireless and Television Assembly

The advanced design of the Adcola Instruments meeting the modern requirements of Television, Telecommunication and

Radar Engineers

SUPPLY FOR ALL VOLT RANGES FROM 617v. to 2301/250v.
3/16in. dia. Bit. Standard Model 2/6
1/2in. dia. Bit. Standard Model 2/6
3/16in. dia. Detachable Bit. Model 30/-

Sole Manufacturers:

ADCOLA PRODUCTS LIMITED

GENERAL OFFICES & WORKS: CRANMER COURT, CLAPHAM HIGH STREET, LONDON, S.W.4. (MACaulay 4272)

Wireless Fundamentals

By E. Armitage, M.A. (Cantab.), B.Sc. (Lond.). This book will prove helpful even to those without previous electrical knowledge. It develops the theory of radio from the fundamentals to an explanation of the superheterodyne principle, and includes Appendixes giving details of more complex aspects of the subject. Illustrated. 18/- net.

PITMAN, Parker Street, Kingsway, London, W.C.2



Designing the Output Stage

HOW TO WORK OUT BIAS VALUES, TRANSFORMER RATIOS AND OTHER IMPORTANT DATA

By J. S. Kendall

THERE are many beginners who manage to obtain some odd valves but, although they are able to find the characteristic of them in a valve data book, are unable to use them. They are either used in incorrectly designed circuits with disappointing results, or they are kept until a suitable circuit turns up. Again, it may be required to replace an obsolete valve with a more modern one (this latter is often the concern of the service engineer).

Fig. 1 is the output stage of a mains receiver or amplifier. The problem in designing is where to start. There are four calculations to be made: they are: the value of the grid resistor, the ratio of the output transformer, and the value of the resistance and condenser in the cathode circuit.

Taking the calculations in the order given, the grid resistor will be dealt with first. If this is too high in value a charge will accumulate on the control grid, and for some peculiar reason it will attain a positive potential and cause a rise in anode current with the result that the valve is quickly ruined by overheating and excessive cathode current. Dr.

Circuit of a 'mains' output stage

Frederick E. Terman, of Stamford University in America, who is a great authority on valves, gives the formula for the calculation of the maximum value as $\frac{10}{G^2}$ M Ω . For those that do not follow

maths readily this means that if the mutual conductance figure, which is given in milliamperes per volt, is multiplied by itself and the result divided into 10, the maximum value of grid resistor will be found. An example or two will be found helpful here.

The EL32 has a slope (that is another name for mutual conductance) of 2.8. If this figure is multiplied by itself we get 7.86, or to the nearest number above—8. Divide this into 10 and we get 1.25. This is the maximum resistance that should, in M Ω , be used as a grid resistance for this valve.

For another example take the EL33. This has a slope of 9.0 mA/V, and as $9 \times 9 = 81$, this gives a maximum resistance value of $10/81$ M Ω . This works out to 125 K Ω , say 100 K Ω to be a safe working value.

Ohms Law

The value of the cathode resistor can be found by a simple application of Ohms Law, which, as most readers know, states that the current flowing in the circuit is directly proportional to the applied voltage

and inversely proportional to the resistance. In short, the current is found by dividing the voltage in volts by the resistance in ohms. In radio engineering we use the milliampere far more than the ampere so, if we divide the voltage in volts by the resistance in thousands of ohms, the result will be in milliamperes. For example, the current through a resistor of 5,000 Ω with five volts applied will be .001 ampere, i.e., 1 mA, but if we use 5 K Ω in place of 5,000 ohms (it is the same thing but in a different mathematical form) the result of 1 mA will be obtained first time.

The first step in the calculation of the cathode resistor is to find the total cathode current, and this is the sum of both the anode and screen current of the valve. For the EL32 this is 32 for the anode current and 5 for the screen, which makes a total of 37. The bias required is —18 volts, and by Ohms Law R is the voltage divided by the current, which gives R as $\frac{18 \times 1,000}{37}$ (the introduction of the 1,000 is to

bring the answer to ohms instead of K Ω). As the tolerance of the average resistance is only 10 per cent., for simplicity of calculation the 37 can be taken as 36, and this then makes the answer a round 500 Ω . For a second example take the EL33; this has a screen current of 4 mA and an anode current of 36 mA. As the bias required is 6 volts, then the resistor required will be $\frac{6 \times 1,000}{40}$ Ω , which, on working out, gives a value of 150 Ω . Quite simple, isn't it?

For finding the value of the cathode condenser take the value of the cathode resistor and calculate the value of condenser which will give an impedance of one-fifth this value at the lowest frequency required to be handled by the stage. (It is frequently easiest to settle for a 50 μ F as this is usually O.K.) If the lowest frequency required is low, say, 100 cycles,

then using the formula $Z = \frac{10^6}{2\pi fC}$ where f is the frequency, π is Pi and is equal to 3.14 and C is in μ F, transposing the formula we get $C = \frac{10^6}{2\pi fZ}$ by

filling in the figures for the signs and letters $C = \frac{10^6}{6.28 \times 100 \times 15} = \frac{10^4}{6.28 \times 15} = \frac{10^4}{94}$ approx., there-

fore C equals 150 μ F for the EL33, but for the EL32 it works out to 45 μ F. In the latter case a 50 μ F would be in order.

The above calculation will depend on just what is wanted in the way of frequency response.

Output Transformer

The choice of the output transformer is in itself quite an art. Here the type of service required must be taken into account, together with the anode current of the valve, frequency response of the circuit, the load resistance of the valve, and the impedance of the speaker used.

There are two ways of labelling output transformers. One is to state the maximum current that can be passed before saturation occurs in the core (this causes the distortion in the output transformer itself), whilst the other is to state the maximum standing anode current. The former way of marking transformers is used by some of the firms that hope to sell inferior goods, but other firms state both the maximum current and the power. This latter way of marking is very useful where the component is to be used in a push-pull circuit, where the maximum current is perhaps five or six times the standing value. This is the case in Class AB2. For a single-ended stage the maximum current is normally twice that of the standing current. Some firms make a transformer to suit particular valves, such as a single 6V6G matching to a 2Ω , 4Ω , 7Ω or 15Ω speaker, but there are many firms that turn out a multi-ratio type.

Take, for example, the Radiospares "Standard" output transformer. This is a multi-ratio type rated at maximum standing current of 40 mA, and gives a choice of 18 different ratios. Given this component how are we to make the best use of it? The turns ratio of a transformer gives a ratio of voltage. The output from a valve is in terms of power. Now

power is E_a^2/R , so we take E_a as the output voltage at the anode of the valve, E_s as the voltage developed across the speaker and R_s as the impedance of the speaker. If the power is the same on both sides of the transformer then E_a^2/R_a equals E_s^2/R_s . Transposing this equation $\frac{R_a}{R_s} = \frac{E_a^2}{E_s^2}$ but $\frac{E_a}{E_s}$ is the turns

ratio of the transformer, then $\frac{E_a^2}{E_s^2} = \frac{R_a}{R_s} \cdot \frac{E_s}{E_a} = \sqrt{\frac{R_a}{R_s}}$

Therefore the ratio for an EL32 matched to a 4Ω speaker will be the square root of the load impedance. For this valve it is $\sqrt{8,000}$ equals 90 divided by the square root of the speaker impedance ($\sqrt{4}$ equals 2), which gives 45.

Take for a second example the EL33. This has a load impedance of 7,000, so that the ratio with a 3Ω speaker will be $\sqrt{\frac{7,000}{3}} = 48$. In this case it

would be permissible to use a ratio of 50:1, as 10 per cent. either way makes very little difference.

The student of radio should obtain a manual of valve data and then try designing an output stage by theory, and then after the calculations have been mastered, try building one of his own design.

The Mini-four

SOME HINTS FROM TWO OF OUR READERS

THIS extremely compact receiver, with its switched tuning, has been found to work very well when fitted to a bicycle. The only alterations to the set itself were the insertion of a five-pin socket and a double-pole isolating switch for the internal batteries. There is adequate room for these on the left-hand side of the receiver, viewing it from the front. As the life of the internal battery is so short, it was thought worth while to run the set off the larger batteries placed in the saddle-bag, thus saving the internal battery for portable use. This suggestion comes from Mr. Corbett, who adds the following details.

Four of the five pins on the socket should be connected to the L.T. and H.T. connections of the set and the batteries should be connected to the associated pins of a five-pin plug. The fifth pin on the socket should be taken to the "hot" side of the output transformer secondary. The connection to the external speaker from the plug should be taken to this fifth pin and the earth pin (usually L.T. negative).

This speaker should be mounted in the back of a suitable sized metal box and a head-lamp face off an old battery lamp cut out with metal shears and bolted on the front. The lamp may then be used with a dynamo, and the speaker will not be so obvious.

The aerial may be of the rod type mounted on the cycle (but insulated from it), or the aerial lead may be taken to a handlebar grip, so that the rider's body acts as the aerial. In this case, a few yards of wire would have to be thrown out if the rider wanted to use the set while dismantled from his machine.

An H.T. of 45 volts is ample and may be made up from nine-volt G.B. batteries, or a 45-volt H.T. battery may be used. The L.T. may be any 1.5 volt cell,

but the larger the better. The internal batteries must be cut out with the isolating switch when the plug is in position or one set of batteries will run down the other.

The Home and Light programmes were received with ample volume except under bridges and near large buildings when the cycle was being ridden. The set may still be used as a portable by disconnecting the plug and switching on the internal batteries.

Aerial Socket

Mr. Coote, of Southend-on-Sea, has made a neat arrangement for plugging in the aerial when an outside aerial is needed with this receiver. The idea is self-explanatory from the illustration below, where, instead of the 4 B.A. C.S. screws supplied by the cabinet makers, he substitutes a 2 or 4 B.A. screw with large or flanged head (diameter between $\frac{1}{2}$ in. and $\frac{3}{4}$ in.) with a hole drilled in one as shown.

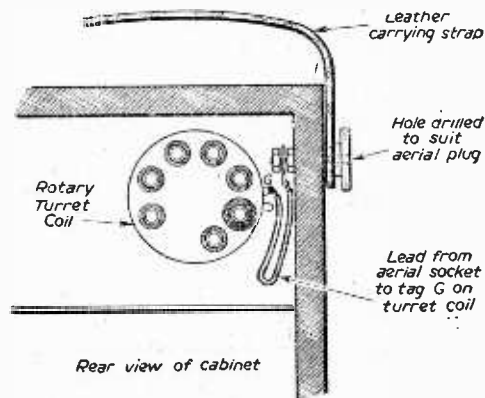

Mr. Coote's idea for an aerial socket.

JOHN FARMER

CIRCUIT-TESTING OHMMETERS, twin scale, 0-1,000 and 100-200,000 ohms and inf.; in bakelite case, complete with test leads and Prods., leather carrying case, new battery; in perfect condition at less than half list price. 25 each, post and reg. 1/4.

PUSH-BUTTON UNITS, radio type, 5-way, each s.p.c.o., brand new, 2/6, post 4d. Also a larger type, 4-way, each 4-pole changeover, fitted independent return 3/6, post 6d.

HAMOFLI CONNECTING WIRE, rubber covered, 1/029 tinned copper; 50yd. coils, 7/6, post 1/-; 500yd. coils, 6/0/-, post 2/-.

Also 1/040, 50yd. coils, 8/6, post 1/-; 500yd. coils, 7/0/-, post 2/-.

All perfect stock.

VARIABLE RHEOSTATS (No. 428), wirewound on vit. steel: (a) 2 ohms, 20 amps., laminated slider, base fitting, 1 1/2 in. long, 7/6, post 1/6; (b) 5.3 ohms, 8 amps., helical traverse control, carbon brush slider, 1 1/2 in. long, 12/6, post 1/6.

RADIO TRANSFORMERS, pri. 200-220-240v., sec. 350-0-350v. at 80 mA., 6.3v. tapped at 4v. at 5 amps., 5v. tapped at 4v. at 2 amps., screen. New, boxed, 20/-.

AUTOTRANSFORMERS, 100 watts, tappings 0-10-120-200-220-250v., other voltages available are 110-190-220-240v. All terminations marked.

Brand new, boxed, 21/-, post 1/3.

TV AUTO TRANSFORMERS, 0-20-250-250-200v., 500 mA., 50 cs., set 8.3v. 7 amps., 0-2-6.3v. 2 amps. Superior make, brand new, boxed, 39/-, post 1/6.

MULTIPLE L.T. TRANSFORMERS, pri. 200-220-240v., sec. 90v. 2 amps., tapped at 3-4-5-6-8-9-10-12-15-18-20 and 24v. Brand new, boxed, 22/6, post 1/3.

M.C. METERS (a) 0-200 mA., basic movement 8 mA., 2in. scale, flush panel mounting, 17/6, post 6d.; (b) 0-50 mA., 2 1/2 in. scale, projection mounting type, 10/-, post 6d.

All new, boxed, **AMMETERS**, 0-9 amps., hot wire, 2 1/2 in. scale, flush panel mounting, brand new, boxed, 10/-, post 6d.

Send to-day for a copy of our 1952 catalogue.

(Dept. A.3),

194, HARBORNE PARK RD.,
HARBORNE, B'HAM, 17

Tel.: HARBORNE 1309.

MODERN ELECTRICS LTD.

164, Charing Cross Road,
London, W.C.2

Phone: TEMple Bar 7587

Immediate delivery from stock

Export enquiries welcomed

SOUND MIRROR RECORDER. The deck of this famous recorder may now be purchased complete. Price £3 0 0

CONNOISSEUR 2-speed Motors ...	22	18	6
GARRARD RC72A 3-speed Auto-changers ...	16	6	6
CONNOISSEUR Pickups—Std. and Microgroove ...	10	0	8
Standard ...	4	1	5
ACOS, G.P.20 P/U ...	3	1	5
ACOS, LP. and Std. Heads ...	2	3	4
DECCA, Pickup ...	3	15	4
DECCA, Motors— 3 1/2 and 78 speed ...	3	18	6
3 1/2 and 78 speed ...	6	8	6

TEST GEAR

AVO— Model 7 ...	19	10	0
Model 8 ...	23	10	0
D.C. Minor ...	5	5	0
Unimiron ...	10	10	0
Univ. Bridge ...	26	0	0
SIGNAL GEN.— Wide Band ...	30	0	0
VALVE TESTER ...	60	0	0
Electronic Test Meter ...	40	0	0

TAYLOR. ALL TAYLOR TEST GEAR IN STOCK. Still available on H.P. Send S.A.E. for catalogue and terms.



DEPT. P.W.
18 TOTTENHAM CT. RD.
LONDON, W.I
MUSEum 4539/2453

Ronette Microphone. The latest Ronette XTAL mike. Freq. 30-7,500 cps. Only 52/-.

Gramophone Equipment. B.S.R., 331-78 RPM Motor Unit, 7/4, plus 1/6. B.S.R. 3-speed Motor Unit, 26.8.6, plus 1/6. Collaro 3-speed Unit, XTAL Heads, 15.9.5. Collaro 78 RPM Changer, 21.3.3. Collaro 3 RC5011, 3-speed, XTAL Heads, 218.16.0.

Decca XMS P/U P. 27, plus 1/-. Connoisseur STD P/U P., 24.11.8, plus 1/-. 8/Light weight, one head, 26.9.0.

LP Head, 71.8. Trans., 15/-.

Fibre P/U.P. 44.3.2. Trans., 25/-.

Chancery XTAL P/U.P. 54/-, plus 1/-. LP Insert, 31/6.

Collaro AC514 Player Unit MAG Head, 56.10.5, plus 2/-.

Garrard Heads.—Hi Fi, 59.11. Miniature, 54/4. Standard, 26/6, plus 1/-. Post. Adaptors, Type A, 9/2. B, 9/7. C, 4/8, plus 1/-. Post.

Collaro ACC Motor, 12in. Table, 210.8.11, plus 2/6.

Garrard A/S Speed Controlled 3S RPM 12in. Table, 25.10.0, plus 2/6.

Garrard ACT2A 3-speed Turnover MAG Head, 218.6.6, plus 3/6.

Decco Coil Pack.—For P.V. Mini Four. 42.10, plus 1/-. M500 Wartite 158, 21/-, plus 1/-. 3in. Elec. Speaker, 15/-, plus 1/-. Miniature O/P Trans., 4/-.

Min 4 meg. Pot. OP. w., 5/-.

Metal Rectifiers, RM2, 123 v., 100 ma. 5/-.

R.M.1, 125 v. 60 ma., 4/6, plus 1/-. Type 20 SFC 240 v. 80 ma., 7/6, plus 1/-.
Decco "C" W.T.F. Coils. Medium and Long wave, 8/- pair, plus 1/-.
Variable Condensers.—Midget 2-gang 500 pf. 7/6, with dust cover, 10/6. Standard, 7/6 with Trimmer. 8/6. 3-gang 500 pf. 7/6. All plus 1/- postage.

Speakers.—3in. ELAC, 15/-. 5in. ELAC, 15/-.

8in. ROLA, 19/6. 10in. Ginnham, 27/6.

12in. Truvox, 32, 59/6, plus 1/3 postage.

New Laser Tape Deck.—3 motors, Erase and Playback Heads, 218.10.2, carriage 5/-. OC2 OSC Coil, 10/-, plus 6d.

Qualitee Deck Kit.—2 Motor, Single Triax, 7 1/2in. HBC, 213.13.0, plus 3/6 post. OSC Coil, 9/6, plus 6d.

Collaro Tape Deck Motors.—Left and right hand drive, 38/6 each, plus 1/6.

Scotch Boy.—EMI—GEC Tape, 35/-, plus 6d.

Polished Cabinet.—Complete with P/U Transformer to take EMI Auto Changer, size 14in. x 14in. Solid Mahogany, 39/6, plus 3/6 carriage.

Rezine Player Case.—Cut for BSR Motor, 39/6, plus 3/6.

ERM 300. Public Address Amplifier.—KT66 Output, Black Mounting, 4 Valves Metered, Brand New. 225. A few only.

Transformers.—6.3 v., 1.5 a., 7/6, plus 9d. 4 v. 2 a., 7/6, plus 9d. 12 v. 1 a., 8/6, plus 9d. 0.3 v. 6 a., 19/6, plus 1/6. Williamson Output, 24.10.0. Oboke, 27.9, plus 1/-.
Choices.—10 h. 150 ma., 16.3, plus 1/3. CH3, 10 h. 75 ma. 300/2, 4/9, plus 1/-. CH4, 10 h. 80 ma., 150/2, 4/9, plus 1/6. 500 v. 1,500/2, 6/6, plus 1/6. 50 h. 20 ma., 1,100/2, 6/6, plus 1/6. 30 h. 20 ma., 6/6, plus 1/6. 20 h. 10 ma., 5/6, plus 1/6.

Condensers.—64 MF, 350 v. BEC, 5/-. 20+30 mf. +25 mf. 450 v. and 25 v. DUB., 7/6. 32+32 mf. 450 v. DUB., 5/-.

32+32 mf. 450 v. BUC, 5/-.

16+8 mf. 450 v. BEC Midget, 4/6. 16+8 mf. 500 v. DUB., 5/-.

8+8 mf. 500 v. DUB., 5/-.

16 mf. 350 v. Hunts w/jend., 2/6. 8 mf. 450 v. BEC w/jend., 2/6. All plus 9d. post.

FULL MAIL ORDER FACILITIES

(Please Add Postage)
Shop Hours, Monday to Friday, 9—5.30 p.m.,
Saturday, 1 p.m.

LYONS RADIO LTD.

3 GOLDHAWK ROAD Dept. M.P.
SHEPHERDS BUSH, LONDON, W.12
Telephone: SHEPHERDS Bush 1729

RADIO EXHIBITION.—During the period of the Exhibition we are holding a SPECIAL SALE. Our premises are only just over a mile from Earls Court, so if in town why not call and inspect a fine selection of Rx's, Tx's, Test Gear, Components, etc., all at clearance prices.

EXAMPLES: R155's from 25. Mains Transformers from 5/-. Type D Wavemeters from 45/-. Avo's and single-range Meters, etc. (Callers only, please, as details by phone or post will be impossible.)

HIGH VACUUM RECTIFIERS.—For those interested in the subject (see p. 352, August issue of "P.W."), we have the following types available: CV1111 at 5/-, CV1133 at 6/6, CV1120 at 6/6, all new and unused. Postage under three, 1/-; any three of the valves 15/-.
OVER UNITS TYPE 3.—A high-grade power unit operated from 200/250v. 50 cps. A.C. mains. Outputs are 220v., smoothed D.C. at 70 mA. and 6.3v. A.C. at 4 amps. Designed for use with the R132 and R1481, but quite suitable for most communications receivers. Made for rack or bench mounting. Panel size 19in. x 7in., and depth over dust cover 1 1/2 in. Front panel is fitted with 0/300 voltmeter and 0/150 milliammeter for indicating output voltage and current, and both input and output are fused, and a two-section filter gives high degree of smoothing. Interior metal work may be store soiled, but exterior appearance good and all tested before despatch to ensure perfect working order. Supplied complete with rectifier valve, circuit diagram and plugs. PRICE 24/-, carriage 7/6.

TWIN FEEDER.—Standard 300-ohm twin feeder ribbon (7/0), brand new condition at the special price of 9d. per yard, or 8/- per dozen yards, plus 7 1/2 d. vd. over 12 yds. Post any quantity, 1/6. Trade enquiries invited for 1,000ft. coils.

VALVES.—6J6, 6K8GT, 6SN7GT, 6BA6, 6BE6, 6BW6, 807, 12BA6, 12T6, 5Y3GT, 8012, 6AM6 (6F12, 6F91, 277, SP6), 8AL5 (6D2, E891, D77, D66), 6F92 (W77, 9D6), 6AT5 (D7H7), 10-7, 717A, 6V6GT, 9/6, 1T4, 1S5, 1U5, 15GT, 3V4, 6SL7GT, 6A8, VR105, PEN48, 8/6, 6AC7, 6K7GT, 6N7GT, VR137, 12SL7, 12SH7, 12SG7, 12S9A, 6B8, 7/6, VR136, 12J5GT, AR2P1, 6/6. VT501, 1625, 5/-, VR54, 4/6. VR22, 2/6. 7F8, 20/-.

VOLUME CONTROLS.—Short Spindle, 2K, 3K, 5K, 100K, 2/6 for 2.

RESISTORS.—Wirewound. 400 ohms, 7,000 ohms. 9d. each.

CHOKES.—3 hy. 200 mA., 4/-.

20 hy. 10 mA., 3/-.

CONDENSERS.—Oil Filled. 4 mfd. 600 v. D.C. w/kg., 7/6. 1 mfd. 6,000 v. D.C., 12. 6. 05 mfd. 16,000 v. D.C., 7/6.

CONDENSERS.—Block. Approx. 2 x 1 x 3 in. high. 1 mfd., 5 mfd. 1 mfd. 2 mfd., 400 v. D.C. w/kg., 03 mfd. 500 v. D.C., 25 mfd. 3,000 v., 1 mfd. 1,000 v. D.C., 1/3 each.

CONDENSERS.—Block approx. 3 x 1 1/2 x 1/2 in. high. 10 mfd. 450 v. D.C. w/kg., 5/-.

400 for 1155 Receiver, complete l.e. valve. These are not strippings, 10/-.

Control Unit Type 179. Black Metal case approx. 4 x 2 x 5 in. Containing 3 switches, condensers, plugs, knob, etc., 3/6.

Control Unit 454a, containing 0.1 mA. Meter, 6 Pots., Switches, Panel Lights, etc. Brand New, 30/-.

J. B. SERVICE

(BEXLEYHEATH), LTD.,
5, MAYPLACE ROAD WEST,
BEXLEYHEATH, KENT

All prices include Postage or Carriage
Regret no lists. S.A.E. for enquiries
please.

SALVAGE RADIO-GRAM CHASSIS. Price £9/17/6. 5 Valve S'Het. 1952 Models. Made to sell at three times this price. Latest Duo-Type Midget Valves (3BA series). Can be built into your own cabinet in combination with one of our salvage auto-change units to make a first-class radio-gram and save pounds. All units guaranteed and tested before despatch.

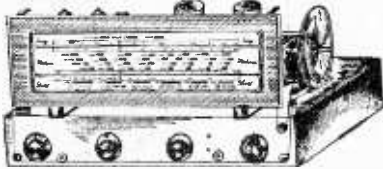

GRAMOPHONE MOTORS. Unused. Made by E.M.I. Need cleaning, but in working order. Complete, but no winder handles. Ideal for building your gramophone wire recorder, saucerpan stirrer, wool, cotton or wire re-winders; or anything requiring a strong spring motor. Speed control down to 33 1/3. Two main springs alone worth price of 25/6. Post and packing, 2/3.



EXTENSION SPEAKERS. New type in baffle stand, with metal fret. 5in. P.M. 19/9. Post 1/-.

VALVES. Surplus and salvage includes: EB91, EF50, EF91, VT60, 6K7, 174, 1R5, at 8/9; 7H7, 7B6, VP133, KT741, at 6/9; SP2, TT11, at 5/9; EY51, 11/9.

CONDENSERS. Tuning, two-gang, from 2/9.

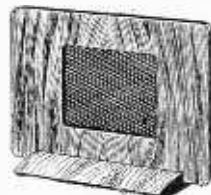

1952 Catalogue available on request (21d. stamp).

C.W.O. of C.O.D. **DUKE'S** 621 Romford Road, London, E.12 GRA 6877 Money Back Guarantee



HOME STUDY

backs radio experience with sound technical knowledge

MANY men who wished to link their radio experience with a sound technological background have received successful instruction by means of an I.C.S. Course. Its value has been proved not only to amateurs but to men who already have a professional interest in radio and television engineering, including those taking qualifying examinations. It is invaluable, also, to Students who wish to prepare themselves for a job in this field. Courses of Instruction include the following:

Complete Radio Engineering, Radio Service Engineers Radio Service and Sales, Advanced Short-Wave Radio Elementary Electronics, Radar, Radio and Television Technology

And the following Radio Examinations: British Institution of Radio Engineers P.M.G. Certificates for Wireless Operators City and Guilds Telecommunications C. & G. Radio Service Cert. (R.T.E.B.)

Write today for our FREE "Radio" booklet, which fully describes the above I.C.S. Courses. Fees are moderate and include all books required. **GENEROUS DISCOUNT TO H.M. FORCES**



Dept. 170a, International Bldgs., Kingsway, London, W.C.2.

THREE FOR THE PRICE OF ONE!!
SPRAGUE TRIPLE 0. mfd. metal Block condensers, 400 v. D.C., 9d. only. Also available U.S.A. metal block 0.5-0.8-3.0 mfd., an amazing bargain at 6d. Metal Tubular 25 mfd. 500 v. 9d. each. 7/- doz. **FOR THIS MONTH ONLY!** 1 ONE EACH OF ABOVE 1/6 1/11 **CO-AX CABLE.** Standard 75/80 ohms 1/2 in. only, 104 yd. **SILVERED MICAS:** 10, 15, 20, 30, 50, 70, 100, 120, 200, 3,000, 4,000, 4,700 pf., 3/8 doz. **POTENTIOMETERS:** 500 k. standard diam., Loose, 1/6, sealed cartons, 1/9. **WIRE WOUND** screwdriver adjustment, 3/6, 9d. only. **VCR97a:** Brand New, in spring crates; tested, full picture, 37/8, carriage 5/-. Limited stock.

VALVES !!
 A—Original cartons. B—Unused and boxed.
 Type A B Type A B
 5243 10/6 — 6KTGT 6/9 — EA50 — 2/6
 6P60 9/6 — 6K8GT — 12/6 EB34 — 2/6
 6J5 6/9 — 6Q7GT 13/- 11/6 KTW61 8/6
 6J5GT 6/8 — 6R7 10/- — Pen 383 9/8 8/6
 6J76 6/8 — 6SH7 6/9 — VU150 10/-
 6K6GT 8/6 — 6K87 7/8 — VU111 3/6 —
 6K7 7/8 — 6V6GT 12/6 10/- 80 — 8/9
MANY MORE AVAILABLE: Send s.a.e. for full list. Orders OVER 5/- POST FREE. Otherwise, 6d. **REED & FORD, 2A, Barley Rd., Ainslie, SOUTHPORT.**

SPECIAL OFFER

For 1 month only. **DISCOUNT** of 6d. per valve on orders for 3 or more. Send stamp for full list.

NEW AND BOXED.—X79, 15/-; X78, 185BT, 12/6; 6AK5, 6K8, 807, EC51, 6BA6, 5U4, 10/-; U41, U41, EBC41, UBC41, ELAL, UY41, 9/6; ELG1, 3Q4, 6P33, 7D5, 8/6; VR105/30, VR150/30, 8/-; 174, EF92, 8/6; 6X5, 6AG5, 6C4, 6SF5, 6L7, 6N7, 6AL5, EB91, 6F7, EA91, 7/6; 1L4, 3A4, 6/9; 802, MS/PEN 6/6. Also VP2B, slightly soiled, but guaranteed 8/6.

ALL-DAY PORTABLE CABINETS again available as previously advertised. Can also be supplied to your specification.

ROOM-TO-ROOM COMMUNICATION without amplifiers or batteries. Can be used up to 100 yds. Only 7/6 per set, plus 1/6 postage.

9d. postage on other orders under £2. **ELECTRAD RADIO, 59, HIGH STREET, BELFAST, N.I.**

—THE MODERN BOOK CO.—

The Radio Amateur's Handbook, by the A.R.R.L. Price 30s. 0d., postage 1s. 0d.
Amplifiers, by G. A. Briggs and H. H. Garner. Price 15s. 6d., postage 6d.
Everyman's Wireless Book, by F. J. Camm. Price 12s. 6d., postage 6d.
The A.R.R.L. Antenna Book, by the A.R.R.L. Price 10s. 6d., postage 9d.
Radio and Television Receiver Troubleshooting and Repair, by A. A. Ghrardi and J. R. Johnson. Price 5s. 0d., postage 1s. 0d.
Wireless Fundamentals, by E. Armitage. Price 18s. 0d., postage 9d.
TV Fault Finding, compiled by "The Radio Constructor." Price 5s. 0d., postage 4d.
Handbook of Line Communication, Volume I, compiled by "The Royal Signals." Price 20s. 0d., postage 1s.
Loudspeakers, by G. A. Briggs. Price 7s. 6d., postage 4d.
Wireless Servicing Manual, by W. T. Cocking. Price 12s. 6d., postage 6d.
Classified Radio Receiver Diagrams, by E. M. Squire. Price 10s. 6d., postage 6d.
Magnetic Recording, by S. J. Begun. Price 25s. 0d., postage 9d.
The Williamson Amplifier, by D. T. N. Williamson. Price 3s. 6d., postage 3d.
Telecommunications Principles, by R. N. Renton. Price 37s. 6d., postage 1s. 0d.
Radio Valve Data, compiled by "The Wireless World." Price 3s. 6d., postage 3d.
 We have the finest selection of British and American radio books in the Country. Complete list on application.
19-23, PRAED STREET (Dept. W.9), LONDON. PADDINGTON 4185.

RADIO G200 ANNOUNCES

VALVES.—NGT1, GDT4C, CV18, E1138, VR92, VR78, 3/9. 6 for £1. KT61, KT66, 7A5gt, 6K7gt, 6K7G, 6N7G, 65H7, 12SC7, 65K7G, 12SG7, KT44, EF22, 6J5gt, EF54, EC52, EF36, 9006, 757, 787, 7H7, 7R7, 7C6, 1457, 7Y4, 719, X61, 6Q7gt, 6L7, X75, 65L7, 12S17, 1K32, 6B8, 6L6G, 387/1291, 68G6, 6CD6, 6E6, 6V6gt, 6AC7, 6K6gt, 617G, 12A6, Pen.46, 2A3, 6B4, 6U5G, 65G7, 6X5gt, KT41, 7A3, 12AT7 (500 mc/s double triode F.C.), 12AX7, 9/- 5763, 9/6.
 Post 6d. Registered 1/-.

ARTHUR HOILE
ELECTRICAL ENGINEERS,
55 UNION STREET, MAIDSTONE, KENT
 'Phone 2 2812

STAN WILLETTS
43, Spon Lane, West Bromwich, Staffs.
SMITHS 3-PLY CLOCKS, 2in. dial, metal case, 29/6, post 9d.
R1155 COMMUNICATION RECEIVERS, complete with 10 valves, brand new, tested and guaranteed, £10.15/-; second-hand, otherwise perfect, £9.15/-, carriage 7/6.
TR9 SHORT-WAVE RECEIVERS, 31-80 metres, complete with 6 battery-operated valves, 15/6, less valves 6/9, post 2/9.
32 MFD. CONDENSERS (U.S.A.) Guaranteed Brand New, 2/- each, 4 for 6/6, post 1/-; BRAND NEW VALVES, 6Q7, 9/6; 6X5, 8/6; 65L7, 8/9; 6SN7, 10/6; 6K7, 5/6; 6V6, 8/9; 6J5, 4/6; 6J7, 5/9; 6AM6, 9/6; 6U5, 6/9; 12U5, 6/9; 12S7, 6/6; 35L6, 8/9; 7R7, 6/9; 14R7, 6/9; 7C5, 10/6; 7C6, 7/6; 7H7, 6/9; 524, 10/6; 2C34, R334, 1/9; 6A50, 2/-; VU111, 2/6; 3B7, 6/-; 3D6, 3/6; 1LD5, 4/6; SP41, 8D2, 4D1, 1/9 each; ATP4, 3/6; post extra.
 1 and 2 Meg. Pots., 1/8 each, 100 k. with switch, 1/8; 5kVW., 10 watt, 2/6; post 6d.
INDICATOR 62, complete with VCR97 and 20 valves, 75/-, post 9/6.
WANTED.—All types of Valves, Receivers and Test Equipment.

Programme Pointers

By MAURICE REEVE



Speeches

THAT this programme is boring, always was boring and ought to be abolished, might well be the terms of a motion to ban—among other boring programmes—the broadcasting of the proceedings of the Pilgrims Society. Anything more paralytically dull, more fulsomely harmful or more sleep-compelling than the speeches made at their dinner to Mr. Eden recently could scarcely be imagined. The same old recollections of the Pilgrim Fathers, the same references to Bunker Hill and 1812—rather sinister now by virtue of their frequent repetition—the same absence of any of the realities of Anglo-American relations—conveying to the intelligent listener the almost certain knowledge that much was being withheld from him because it would not be “good” for him to know it—the general atmosphere of hypocrisy and of “you scratch my back while I scratch yours” pervading the whole proceedings, made for a sickening and repellant forty-five minutes (incidentally, it ran well over its time and ruined an excellent programme Louis Kenner was scheduled to give).

Mr. Eden, for all his charm and popular photogenic personality, imparts a peculiar sentimental rise and fall to his radio voice which, during the course of a speech of any length, often becomes extremely monotonous. Coupled with entirely irrelevant references to the greater speed of motor cars to-day compared to fifty years ago—when the Pilgrims were founded—and to the frequency with which the Atlantic is crossed by air now as to then, made up an oratorical performance that was anything but stimulating. Next time I listen to a Pilgrims Banquet I shall play a game of darts. They will not put me off my stroke.

Plays

“Murder on the Map” was a report by Wynford Vaughan Thomas on threats to our famous beautiful landscape by the encroachments of modern science, industry, housing and what you will. A very good programme and Mr. Thomas a fervid and eloquent defender of beauty and “hands off.” Not always convincing, I’m afraid, for the very reason that, until our population is drastically reduced, the amenities which fifty millions and more require and, by any reckoning, are entitled to, will eat away our matchless inheritance. It needn’t be uncontrolled spoliation, of course, but some of it, alas, must go, unless the country is to become the playground for millions of occasional visitors from the cities and the slums.

What better radio fare can be demanded than a Somerset Maugham comedy well acted and produced? This we had in “Penelope,” in which a young, inexperienced wife is counselled by a mature man of the world on how to bring her erring young husband back to his proper place, to wit, at her feet. All was accomplished with the utmost gaiety and charm by everyone concerned. D. A. Clark-Smith, Nan

Munro and Max Adrian were the chief protagonists, and Peggy Wells was the capable adaptor for broadcasting.

Another play of not a dissimilar character though rather solid, but of great worth and merit, was “Love and Geography.” As the author’s name is probably as difficult for an Englishman to write as to pronounce, I will kill two birds by giving myself some practice in the former by writing it here, and the reader the opportunity of reading it—in the same place—Bjørnstjerne Bjørnson. Norwegian, needless to say.

In this piece maps and travel threaten to play the part of co-respondent. But the situation is saved with great charm and philosophic wisdom. Cecil Trouncer, Avice Landone and Catherine Lacey were the contestants this time, with Cynthia Pughe the adaptor for broadcasting. What a pity this sort of stuff can never reach the boards! It is our fault and not ———’s.

A third play which is by way of being a masterpiece, was Rosetand’s “l’Aiglon,” the story of the loyalty Napoleon’s son rallied round himself and of his unavailing efforts to restore the Buonapartist dynasty to the French throne. The story is highly romantic and much beautiful writing goes to the telling of it. Marius Goring headed a large cast, which must receive my compliments *in toto* as space forbids their separate mention. The distinguished playwright, Clemence Dane, was both translator and adaptor for broadcasting. There must be quite a staff of these latter at Broadcasting House.

Pianist

And lastly, Claudio Arrau completed his noble and Herculean task of playing all the Beethoven Sonatas and the 33 Variations. The best was as good as we are likely to get from any pianist these days.

Stories

Four other programmes of more than ordinary merit are left for mention. “The Voice of the Actor” was of exceptional interest in comparing past and present masters of the histrionic art. My word, how methods and styles have changed! Couldn’t singers and pianists, etc., be similarly brought together? “The Banning of the Mikado” attractively narrated an incredible story which out-Gilberted Gilbert in sardonic humour. We shall probably do the same again when the next Japanese Crown Prince honours us similarly. “SHAPE,” another Vaughan Thomas documentary, purported to tell a frightfully important story. But, as with the Pilgrims Dinner, one couldn’t help feeling that all that was vital and really important was being left unsaid.

OPEN TO DISCUSSION

The Editor does not necessarily agree with the opinions expressed by his correspondents. All letters must be accompanied by the name and address of the sender (not necessarily for publication).

Converting to Push-pull

SIR,—Regarding the article in your July issue, the following comments may be of interest.

The Schultz push-pull arrangement is not self-balancing, and thus, if the output transformer is electrically centre-tapped, the alternating currents in the two halves of its primary being unequal, one valve (the one with the signal on its control grid) delivers more power than the other. It is possible that the degree of unbalance resulting from the use of the circuit constants on page 322 would pass unnoticed, but in any case, it can be minimised by increasing the value of R_c .

In the article the suggestion is made that the potential drop across R_c may be regained by modifications to the H.T. smoothing arrangements. It seems probable, however, that a more elegant system would be to feed H.T. to the anodes and screen grids of the output valves directly from the cathode of the rectifier, i.e., use the voltage across the reservoir capacitor. The voltage at this point is likely to be high enough to offset the drop across R_c . If the voltage is higher than is necessary to compensate for the drop due to R_c , then R_c can be increased with consequent improvement in the balance of the alternating anode currents. The voltage across the reservoir capacitor will admittedly have a strong alternating component, but as the system is closely balanced for an input applied via the H.T. supply, very little—if any—hum will be introduced. Further, the hum on the smoothed H.T. rail will fall due to the reduction in the current flowing through the smoothing filter.

In the article it is implied that a $32 \mu F$ reservoir capacitor may be used. While in many instances this is likely, readers should ensure that such a value would not result in the peak charging current exceeding the limit laid down by the valve makers for the particular rectifier in use. If the maker's figure would be exceeded by such a value there seems little to be done. The normal solution in such cases of increasing the series impedance of the source feeding the rectifier would tend to offset the effect of an increase in capacity.

In conclusion, it may be mentioned that this push-pull circuit is also known as "long-tailed pair," the name being a reference to the apparent increase in the length of the grid-base of valves used in such a circuit.—S. C. MURISON (Surbiton).

Condenser Testing

SIR,—I note from the remarks of Mr. Hindle in your July issue that he is not in favour of the addition of a potentiometer resistance to adjust the voltage given by a power pack as mentioned in his article of February. I still contend that a potentiometer gives more flexible control to the neon test circuit for general radio condensers and condensers used in tuning circuits.

Many power packs give a voltage in excess of 400 volts if measured with an electrostatic voltmeter and with a discharge resistance of $5 M\Omega$ the pulse of the neon lamp can be so rapid on small condensers that it cannot be easily timed.

It has been found that with a $0.1 \mu F$ condenser, for example, the pulse at about 270 volts applied pressure can be slowed down to measurable timing and comparison made with equal or equivalent condenser values.

The potentiometer can easily be marked so that the minimum voltage to suit the striking voltage of the lamp is not exceeded.

In timing circuits for traffic signals ("robots," they call them in South Africa) where a $5 \mu F$ condenser discharges through adjustable resistances, and the control relays are "triggered" by neon lamps, the D.C. source from the "transrector" is stabilised by a valve circuit, and by potentiometer control, regulated to a lower value. In tests on many condensers with a capacity bridge the value of the capacity of the condensers has been found to be rarely far off the rated value, but the insulation resistance between plates can, in humid tropical climates, fall from hundreds of $M\Omega$ to a few $M\Omega$ when kept in stock for a few weeks only.

Condensers which fail through inadequate sealing against the ingress of moisture are useless for traffic control and X-ray timing devices.

Mr. Hindle mentions the straight part of the charging curve of a condenser, yet a reference to the equation for the time constant in terms of P.D. and time indicates that the charging curve cannot be straight at any portion.

The "Osglim" lamp was mentioned because it should be easily procurable and, incidentally, many types of neon lamps are fitted with internal high resistance although this fact is only ascertainable by opening up the cap.

(Continued on page 437)

Whilst we are always pleased to assist readers with their technical difficulties, we regret that we are unable to supply diagrams or provide instructions for modifying surplus equipment. We cannot supply alternative details for constructional articles which appear in these pages. WE CANNOT UNDERTAKE TO ANSWER QUERIES OVER THE TELEPHONE. If a postal reply is required a stamped and addressed envelope must be enclosed.

OUTSTANDING BARGAIN

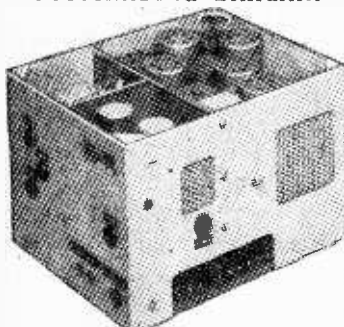

G.E.C. V.H.F. RECEIVERS

The receiver is complete with 10 valves, as follows: H.F. and 1st Det. stages, ZA2, 954 or EF50's. Local oscillator, Det. 19, three L.F. stages KTW83's, Det. and A.V.C. D63 Double diode. L.F. H63, output KT63. Noise Suppressor D63. Power requirements: 6v. 3 a. 270v. 80 ma.

Technical Data

Frequency Range
 (A) 128-131 mc/s (2134-229 metres).
 (B) 95.5-100 mc/s (3.14-3.0 metres).
 (C) 78.5-82 mc/s (3.85-3.68 metres).
SPECIFY RANGE REQUIRED.
 Intermediate Frequency 8.3-9.8 mc/s.
 Oscillator Crystal Controlled.
 Sensitivity 3 microvolts for 50 MW audio output. 30% modulation as 130 mc/s. Input impedance 72 ohms.
 Housed in a grey enamel steel case 10in. x 9in. x 7in. Total weight 22 lbs.
 £2/9/6, plus 5/- carriage.

H.P. RADIO SERVICES LTD.,
 Britain's Leading Radio Mail Order House,
 55, County Road, Walton, LIVERPOOL 4
 Tel.: AINTREE 1445.

Best Buy at Britain's

COMMUNICATION RECEIVER R1155. Absolutely BRAND NEW and in perfect working order, complete with technical data, £11.19.6, plus 10/6 carriage and packing in original transit cases. Technical details for 1/3 post paid.

FEW ONLY, slightly used R1155's, air tested, for only £7.19.6, plus 10/6 carriage. **R1155 POWER PACK AND OUTPUT STAGE** in black case, size 8 1/2 in. x 6 1/2 in. x 4 in.—enables the receiver to be operated direct from A.C. mains without any modifications. Price £4.10.0, plus 3/6 carriage.

SPECIAL OFFER of brand new R1155, Power Pack and new boxed 6V. speaker for only £17.10.0 carriage paid.

SPECIAL PURPOSE VALVES VT501 (TT11), 5/-, 954 2/6, VR136 (EF54) 6/6, E1148 2/6, VR65A (5E41) 3/6, 2C34 (RK34) 2/6. Hundreds of other types in stock. Post 6d. extra for 1-4 valves.

SYLVANIA RED EF50's, Brand New at 8/6 each. British types at 5/- (tested).

30 VOLT TRANSFORMER, standard primary, secondary 30 volts 2 amp. tapped to give 3, 4, 5, 6, 8, 9, 10, 12, 15, 18, 20 and 24 volts. Price 17/6, plus 1/- post. Brand new and guaranteed.

METAL RECTIFIER, 12 volt, 21 amp. full-wave bridge at 12/6, plus 6d. post.

SPRAGUE CONDENSERS, .01 mF. 1,000 volt, .02 mF. 750 volts at 7/6 doz. .005 mF. 1,000 volts, .002 mF. 1,000 volts at 6/- doz. All metal cased tubulars wire ended. Micamold ditto .1 mF. 350 volts at 7/6 doz. Small mica TCC Condensers .001 mF. CM200 at 6/- doz.

ELECTROLYTIC CONDENSERS, 32 mF. 450 volts wkg. in metal can 1/- each to callers, or 6 for 7/6, post paid.

CHARLES BRITAIN (RADIO) LTD.
 11, Upper Saint Martin's Lane, London, W.C.2. TEM.0545
 Shop hours, 9-6 p.m. (9-1 p.m. Thursday)
— OPEN ALL DAY SATURDAY —

NORMAN H. FIELD
 68, HURST ST., BIRMINGHAM 5.

Mail Order Department:
 54-65, Church Lane, WOLVERHAMPTON.

VALVES
 At 12/6: 6K8, EF91, ECC32, 6SN7. At 11/6: 6Y3/SZ, 9Q7, KT61, KT65, 6F8, 6K6. At 10/-: 6SS7, PEN45, 50Y/GT. At 9/-: ARP6, 6X5, KT63, IT4, 1S4. At 7/6: 12SL7, 7R7, 77, 6J7, VR150, 6G6GT, VR119, 6ACT, OZ4, 12A6, 12AC7, VR126, At 7/-: 6BB, 1G8/GT, 1A5/GT, 6K7G, VR53, ER39, EF36, 1616. At 6/6: EF50, VR51, 6H6, ARP12, VP23. At 5/6: 12J5, 6SH7, 3D6, 6SS7. At 5/-: 2A3, VU133, 12SH7, 6J5GT, 1625, TV51, PEN20A, VR118, KT3. At 4/6: SP61, VR65, 12H6, VU120. At 3/6: RR72, ARP3, 9D2. At 3/-: VR13, 2155G, VU111, RK3, 2C34, VU133, HL2, VR21, VR66, P61, VR65A, SP41. At 2/6: VR54, EB34, D1, VR78, CV6.

E.H.T. TRANSFORMERS—2,500 v. 5 m.a. 4 v. 2 amps, 0-2.4 v. 4 amps 210-250 v. 50 cycles. Completely wax impregnated. 42 6 each.

MAINS TRANSFORMERS—Input 230 v., AC. Output 18 v.-26 v.-44 v. at 2 amps. 12/6 each.

RFARY CONVERTERS—Approx. 6 volts input and 220 v. at 80 m.a. output. 12/6 each.

MODULATION TRANSFORMERS—U.S.A. manf. potted. P/P211 to single 211. Ratio 1 to 1.2, 100 w. size. Suitable P/P307's to 807 single. 7/6 each.

1155 LOOP AERIALS, D.F. 8'6 each. 500 KC/S CRYSTALS, 7/- each.

METERS marked AIR/OIL Moving Coil base 200 Microamps. Very sensitive. 2 in. square, 7/6 each.

METERS—0-1 amp. R.F. Thermo-couple, 2in. square, 5/6.

BATTERY AMPLIFIER—A1368 with 2 valves 210LF and C21, 2 v. and 120 v. 15/- Brand New, plus 1/6 if carrying case required.

Kit of 12 Valves for Viewmaster at 68-4-0.
 Please add something for Postage. Money Back Guarantee.

One coil, 4 circuits. Simple receivers from a crystal set to a 3 valver. Full circuits enclosed. T.R.I. Coil. 5/- P.P. 6d.

HILLFIELDS RADIO
 8, BURNHAM ROAD,
 WHITLEY, COVENTRY

SUPACOILS

SIMPLIFIED SYSTEM DEFINITELY ENABLES ANYBODY TO BUILD FIRST-CLASS SETS, ETC. We supply full constructional details for a purely nominal charge and as an introduction to our latest

CONSTRUCTOR'S HANDBOOK (Price 2/6 only)

Incorporates complete details for building a **CHEAP, HIGH-EFFICIENCY COIL PACK**

together with **14 CIRCUITS AND ILLUSTRATIONS** of Receivers, Amplifiers, etc., which YOU can build

Lots of other information too! **DON'T DELAY**

Send 2/6 now for our **LATEST HANDBOOK** complete catalogue and monthly bargain list sent with each handbook

Obtainable only from:—
SUPACOILS MAIL ORDER OFFICE
 98 Greenway Ave., London, E.17



The "Fluxite Quins" at Work
 "Do these people know what they're about? We can't see to FLUXITE! Smoked out! It's a lick to me..."
 "It's your blowlamp!" cried EE.
 "Dropped clean down the chimney, old scout!"

See that **FLUXITE** is always by you—in the house—garage—workshop—wherever speedy soldering is needed. Used for over 40 years in government works and by leading engineers and manufacturers. Of all ironmongers—in tins, from 1/- upwards.

FLUXITE
 SIMPLIFIES ALL SOLDERING

Write for Book on the Art of "SOFT" Soldering and for Leaflets on CASE-HARDENING STEEL and TEMPERING TOOLS with FLUXITE. Price 11d. each.
FLUXITE Ltd., Dept. W.P.
 Bernondesty Street, London, S.E.1.

LONDON CENTRAL RADIO STORES

Owing to our large contract we are still able to supply

PHILCO 5-VALVE RECONDITIONED SETS
 5 VALVE—UNIVERSAL MAINS—AND A.C.

These superhet receivers have all been thoroughly overhauled at our works. Ready for immediate use and GUARANTEED. We have sold over 3,000 of these sets all over the country. If in London call and see them for yourself.

ALL-WAVE TABLE MODEL, incorporating two-speed tuning and provision for normal aerial or dipole. Medium or dark walnut cabinet. Size 18 1/2 x 20 x 9 1/2 in. Excellent performance. **150/-**

LARGE TABLE MODEL, in light walnut cabinet only, size 19 x 18 x 10 1/2 in., large dial in metres and frequency. Exceptional high gain using high "Q" I.F. transformers and special aerial circuit. Normal or dipole aerials may be used. **80/-**

MEDIUM TABLE MODEL, known as the "Cathedral Model," receiving all British and European stations with great clarity and freedom from interference. Normal or dipole aerial input. Available in light or dark oak. **80/-**

Cabinet size, 19 x 14 x 10 in. **80/-** Plus 10/6 per set carriage and packing.

We are still buyers of **GOOD USED or NEW EQUIPMENT—AR88's, D.B. 'SCOPES, METERS and all kinds of TEST GEAR, CONVERTERS, etc.**

LONDON CENTRAL RADIO STORES
 23, Lisie Street, W.C.2 GERrard 2869

YOU can become a first-class RADIO ENGINEER

Our Home-Study Courses in Radio, Television and Mathematics are a proved success. Students tell us how our training has helped them to earn money in their spare time, start businesses of their own, or get bigger salaries. One student recently reported that he is now earning £1,600 a year. Send for free details. Write your name and address on a postcard (2d. postage) and address it to the Principal:

R. HEATH BRADLEY, T.C.R.C.,
36, Northfield Road, Ringwood, Hants.

T. & C. RADIO COLLEGE
HOME-STUDY COURSES IN
ELECTRONICS & MATHEMATICS

IS YOUR SLIP SHOWING?



Let's be honest — we all make a slip sometimes, but when it comes to radio construction don't take a chance on unknown and untried circuits! With OUR series of unique LIFE-SIZE, "EASY-AS-ABC" CONSTRUCTION SHEETS, matched components, punched chassis and ALIGNED UNITS radio assembly is really

easy for the Home Constructor! If you have average ability you can tackle any or all of our LARGE RANGE OF GUARANTEED OUTFITS knowing that failure is impossible!

Send 2/6 NOW for your copy of "THE HOME CONSTRUCTORS HANDBOOK." The NEW 2/52 ISSUE is obtainable by mail ONLY from

RODING LABORATORIES (PW9)
301, Hurn Airport, Christchurch Hants.

CABINETS

To YOUR specification. Send 9d. for illustrated catalogue.

COMPONENTS

We hold extensive stocks of radio and television components.

GRAM MOTORS

All the latest Auto-changers and Pick-ups available.

AMPLIFIERS

Send for details of our latest models.

SPEAKERS

All sizes and types available. We stock the full GOODMANS range.

TELEVISION

All the VIEWMASTER parts are stocked.

Send 6d. for complete and latest lists.

LEWIS RADIO CO.

All correspondence to :
(Dept. K.15.)

322, HIGH RD., WOOD GREEN, LONDON, N.22

Callers to :

120, GREEN LANES, PALMERS GREEN, LONDON, N.13
(Near Bowes Road)

Phone : BOWes Park 6064

BARGAIN LINES

GARRARD 3-speed GRAM UNITS with two separate hi-fi Decca Magnetic or Acos GP crystal pickup heads, price £12.5.0. **GARRARD HG2A 3-SPEED AUTO-CHANGERS** with ditto, price £19.13.4. **CONSOLE RADIOGRAM CABINETS**, 30in. high, pull-out motorboard cut for autochanger, price £6.17.6. **PORTABLE RECORD PLAYER CABINETS** in brown rexine, 39/6. **PORTABLE MICROGRAM CABINETS**, take gram unit, amplifier and 6in. speaker, price 57/6. **GENUINE new ACOS GP19 and GP191P P.U.** heads, £4 per pair. "SYMPHONY" AMPLIFIER, Bass, Treble and Middle controls, scratch-cut, negative feedback, 10 gns.; **BASS REFLEX CABINET KITS**, stand 30in. high, fully cut, complete with all screws, nails, deflector plate and felt. 6in. speaker model, 85/-; 10in. speaker model, 97/6; 12in. speaker model, 107/6. Carriage 7/6 extra. Ready built, 7/6 extra.

Send 2d. for full catalogue.

NORTHERN RADIO SERVICES, 16, Kings College Road, London, N.W.3. PR1mrose 8314.

NEW SENSATIONAL POCKET SIZE

"FLICK-A-DISC" VALVE CHART

(Copyright Reserved)

A FLICK-O-THE-DISC AND YOUR VALVE EQUIVALENT IS AT YOUR FINGERTIPS

Instant Equivalents to over 300 English, American and Ex-W.D. VALVES from 1.4 to 40 volt valves.

A MUST for EVERY Radio Engineer

From :
Richard EDEN, Ltd.,
93, Westbourne Grove,
London, W.2.

TRADE ENQUIRIES INVITED

2/6

Each. Post 3d.

Established over 30 years

ELECTRADIX RADIOS

SPECIAL PARCEL OFFER!

Parcel containing good selection of components valuable in every junk box. All clean, dismantled from Government 7/6 post surplus : 7 lbs. 1/-.

Send orders to Dept. G.

214, Queenstown Road, London, S.W.8

Telephone : MACaulay 2159

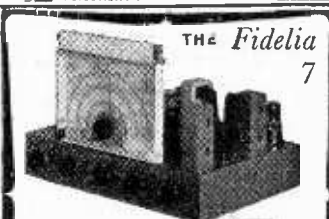

Luxury 7-valve Radiogram chassis £21-15-0. Also 9-valve De Luxe Chassis at £25-5-0, and 10-valve model at £31-10-0. Data sheets on request.

ELECTRO Acoustic DEVELOPMENTS
2 Amburst Road,
Telcombe Cliffs, Sussex

TELEVISION COMPONENTS

for the

"Practical Television Receiver" **VIEWMASTER, E.E. TELEVISOR** and **HAYNES TP38** IN STOCK

Price Lists available on request.

J. T. FILMER,
Maypole Estate, Bexley, Kent.
Tel. : Bexleyheath 7287

NEW GOODS ONLY

CONDENSERS.—450 v. wkg., 1 mfd., 2/9 : 4. 3/2 : 8. 3/4 : 16. 4/6 : 32. 5/10 : 8-8. 4/9 : 8-16. 6/- : 16-16. 7/3 : 500 v. wkg., 1 mfd., 3/- : 2. 3/3 : 4. 3/5 : 6. 3/6 : 16. 6/- : 32. 9/6 : 8-8. 6/6 : 8-16. 9/8 : 16-16. 9/9 : 25 x 25v., 25 x 50 v., 50 x 12 v., 2/3 : 50 x 50 v., 2/6. Tubulars, 500 v. wkg., up to .0005, 8d.; to .006, 10d.; to .04, 11d.; to 1. 1/2 : 2. 25 : 1/6 : .5. 2/3. Mica, up to .002, 1/- : to .01, 1/6 : 8/11. Mica, up to 100 pf., 9d. : to 500 pf., 1/- : to 1,000 pf., 1/2 : 2,000, 3,000 pf., 1/3.

VOLUME CONTROLS.—Long spindles, all values, 3/3 : with sw., 5/3 : D.P. sw., 6/- : Semi Midg. type, 1. 1. 2 meg., 4/- : with sw., 5/9 : D.P. sw., 6/6 : Wire Wound, less sw., 1 K. to 80 K., 6/6 : 100 K., 7/9.

RESISTORS.—All std. values, 1 W., 5d. : 1 W., 6d. : 1 W., 8d. : 2 W., 1/- : 3 W., 1/3 : Wire Wound, 5 W., up to 5 K., 2/- : 10 W., up to 10 K., 2/9.

Terms : Orders up to 10/-, post 6d.; up to £1, 9d.; over post free. Cash with Order. Obtain copy of our Lists, 5d., post free.

22, FRANCIS STREET, SCUNTHORPE, LINCOLNSHIRE

H.A.C. SHORT WAVE EQUIPMENT

Noted for over 19 years for S.W. Receivers and Kits of Quality.

Improved designs with Denco coils :
One-Valve Kit, Model "C" Price, 25/-
Two " " " " " " " " 50/-

All kits complete with all components, accessories, and full instructions. Before ordering call and inspect a demonstration receiver, or send stamped, addressed envelope for descriptive catalogue.

"H.A.C." SHORT-WAVE PRODUCTS
(Dept. TH), 11, Old Bond Street, London, W.1.

(Continued from page 434)

It has been found with a reduced supply voltage that the cheap neon lamps, with a low striking voltage of about 90 volts, and obtainable in most stores, can be usefully employed for condenser testing.

Trusting this information may be of interest to your readers.—K. COOMBS (Cape Town, S.A.).

Receiver Design at V.H.F.

SIR,—I note in your July issue of PRACTICAL WIRELESS, on page 316, one of your contributors labels the first valve in the circuit as ECH33. I think this is probably a typographical error and should be ECH35.

I thought I had better mention this as we have already had an enquiry or two for ECH33, and we can trace it only to this particular diagram.—C. H. GARDNER (Mullard Ltd.).

Cycle Radio

SIR,—Out of interest and enthusiasm for radio, I have succeeded in making a four-valve receiver for my bicycle.

Using full-size valves, it runs on as low a voltage as 60 volts H.T., 2 volts L.T., size being 7in. × 4½in. × 3in., I have the battery, L.T., etc., in a box in the saddle-bag, with frame aerial round inside the box. Reception is perfect; I can get stations all the way round the scale and on long or medium wave.

I've braced the valves with rubber inside the chassis against shock.

It will work a midget speaker, but I prefer to use those small button phones.

I don't lose any volume when riding, except on a sharp turn, but I don't lose audibility, just slight volume is lost.

I have the set mounted on the handlebars, and the rest of the gear—aerial and batteries, etc.—in the saddle-bag.

It is a four-valve straight built on an amplifier panel; three knobs, selectivity, volume and tuning switch is incorporated with the volume switch.—R. ALEXANDER (Whitstable).

Balanced Twin Speakers

SIR,—I was interested by the letter from G. Hurrell, in the June issue.

I built my own amplifier and I am using a home-made cross-over network at 3,000 c/s, feeding a 12in. bass speaker and a 5in. "tweeter." Both speakers are "doctored" to give improved results and were originally quite cheap.

However, the result is excellent quality which—in my opinion—is more realistic than most. But it is very "squeaky."

I, too, have had to attend concerts to gain a fair estimate of the balance of a live orchestra.

I have come to these conclusions. The majority of commercial receivers "cut off" at about 4,000 or 5,000 c/s. This is the "standard" by which reproduced music is judged.

Standard records, even when they have the higher frequencies, are no better for it since your ears tend to become "deaf" to the "needle hiss," and so to the high frequencies. Anyway, most people have the sense to cut the top on standard records to get rid of the hiss.

I hope my experience has done something to reassure Mr. Hurrell and I hope he "sticks to his guns."—G. J. BADMAN (Street, Som.).

Sign of the Times

SIR,—I read with some amusement, the comments by A. J. S., in his futile attempts to purchase a volume control and switch in his native town. I have come to the conclusion, that most radio shops look with disdain upon the struggling amateur. There are, of course, exceptions, but they are few and far between. My advice to A. J. S. is why trouble the locals for anything, when we have, at our elbow, everything which is required in PRACTICAL WIRELESS, including catalogues advertised by a goodly percentage of radio dealers, and it only needs a stamped addressed envelope to either, and their shop window will be placed before you, at a price no amateur would refuse.—W./O. T. WHITE (R.A.F., West Kirby).

"Amateur Transmitters"

SIR,—May I reply to the letter by Mr. R. Lockwood, of Leicester, in the August issue.

Mr. Lockwood states that most amateurs to-day appear on the air as self-styled comedians and that little technical matter is discussed. He also goes on to say that the amateur does not care what type of signal he puts out so long as he gets on the air.

I, as an officer of the radio society embracing most of the amateur transmitters in his home town, cannot allow this statement to go unchallenged.

The quality of the transmissions put out by members of the Leicester Radio Society are without exception equal to "BBC performance," and I suggest that Mr. Lockwood listens to the local net any Sunday morning on 1900 kc/s, when he will find enough technical matter to last him the whole of the week.

He did not state which frequency band he generally uses or the type of receiver he operates, as poor quality is often the result of bad receiving conditions.

Finally, may I state that if Mr. Lockwood is so interested in technical tuition, he will be made welcome at any of the meetings of the local radio society, where he can "air his views" and actually take part in a local transmission. The society meet every first and third Monday in the month, at the Holly Bush Hotel, and announcements appear frequently in the technical press.—C. L. WRIGHT, B.Sc. (G3CCA) (Publicity Officer, Leicester Radio Society).

Editorial and Advertisement Offices: "Practical Wireless," George Newnes, Ltd., Tower House, Southampton Street, Strand, W.C.2. Phone: Temple Bar 4363. Telegrams: Newnes, Band, London. Registered at the G.P.O. for transmission by Canadian Magazine Post.

The Editor will be pleased to consider articles of a practical nature suitable for publication in "Practical Wireless." Such articles should be written on one side of the paper only, and should contain the name and address of the sender. Whilst the Editor does not hold himself responsible for manuscripts, every effort will be made to return them if a stamped and addressed envelope is enclosed. All correspondence intended for the Editor should be addressed: The Editor, "Practical Wireless," George Newnes, Ltd., Tower House, Southampton Street, Strand, W.C.2. Owing to the rapid progress in the design of wireless apparatus and to our efforts to keep our readers in touch with the latest developments, we give no warranty that apparatus described in our columns is not the subject of letters patent. Copyright in all drawings, photographs and articles published in "Practical Wireless" is specifically reserved throughout the countries signatory to the Berne Convention and the U.S.A. Reproductions or imitations of any of these are therefore expressly forbidden: "Practical Wireless" incorporates "Amateur Wireless."

BOOKS

BRITISH SHORT WAVE LEAGUE is devoted to the interests of amateur radio enthusiasts. Publishes 12-page "BSWL Review," monthly (members only). Offers many services and activity departments. World wide membership. Founded 1935. Apply for details to: **BRITISH SHORT WAVE LEAGUE**, 55, Victoria St., London, S.W.1. (Abbey 2384.)

AMERICAN MAGAZINES, 1 year incl., "Audio Engineering," 28/6; "High Fidelity," 28/6; Radio Electronics," 32/3, etc. Send for free booklet. **WILEN LTD.** (Dept. 40), 101, Fleet St., London, E.C.4.

I.P.R.E. TECHNICAL PUBLICATIONS: 5,500 Alignment Peaks for Super-heterodynes, 5/9, post free. Data for constructing TV Aerial Strength Meter, 7/6. Sample copy The Practical Radio Engineer, quarterly publication of the Institute, 2/-; membership and examination data 1/-; Secretary, I.P.R.E., 20, Fairfield Rd., London, N.8.

35 MODERN Radio Text-books for sale; bargain to student. Box No. 223. c/o PRACTICAL WIRELESS.

RECEIVERS & COMPONENTS

HOME CONSTRUCTORS, short wave radio, television. Send for free list. Components, Valves, Kits, Speakers, etc. **THE RADIO EQUIPMENT COMPANY** (P.W. Dept.), Castor Rd., Brixham, Devon.

EVERYTHING for radio constructors. Condensers, Coils, Valves, Resistors, etc. Send stamp for list. **SMITH**, 98, West End Road, Morecambe. Quick service.

MAKE a Superhet for £6 or T.R.F. for £5/5/-, including valves and cabinet, full instructions 1/6; midget I.F.T.s, 7/8in. sq., 465 KC, 8/6 pr.; ex-equip. Valveholders, used but in perfect condition, International or Mazda coil, 1/9 doz.; 2 m/m Siles ing, 1/- doz.; yds.; 1 gr. asst. BA Screws and Nuts, brand new, 5/-; Tub. cond. new, 1/ 350v, 2/9 doz.; 1 x 500v, 4/- doz.; Electrolytics, guaranteed, aluminium can type, std. size, 8 mfd x 500v, 1/9 ea., 18/- doz.; 200 mfd x 12v, 6d. ea., 4/6 doz. Min. P. and P. charge, 1/-. Thousands of components available; latest list 3d. **SUSSEX ELECTRONICS LTD.**, Princes Street, Brighton.

CONDENSERS.—Special offer, limited stocks, .01+.01 at 450v, 1/-; 50 at 12v, reversible, 1/6; .5 at 3.5kv, 3/6; 1 at 400, 9d.; 2 at 250, 9d.; 1 at 450, 9d.; .002 mica, 6d.; 500 at 12v, 1/6; Philips 32, 6/8; .5 at 150, 9d.; 0005 tuning, single, 4/-; 2-gang 5/-; 3-gang 7/6. **C.T.S. ELECTRONICS**, 44, Lower Church Street, Croydon.

SALE 1 V. Battery Set, perfect, in case, 25/-, post 1/6. Standard iron-core IFS, new, 5/6 pr., post 6d. **A. VANSTONE**, Cleland, Ashstead, Surrey.

M & L COIL w/react. and Circuits 3/6; M & L Crystal Coil, 2/6. Lists 4d. **CARTER'S**, 578, Washwood Heath Rd., B'ham, 8.

READ, BUY AND BENEFIT! 10in. P.M. Speakers with trans. in cabinet, 35/- each! T.C.C. 8-8 mfd, 450v, cans, 2/6; 16 mfd, 450v, 2/-; Micamold, 1/ mfd, 7/6 doz.; Octal Plus, 6d. each; RK34 twin-triode 10-watt Valve, 25/-; dozen! Add postage. **ELECTRONIX**, 220b, Canterbury St., Gillingham, Kent.

RATES

5/- per line or part thereof average five words to line, minimum 2 lines. Box No. 1/- extra. Advertisements must be prepaid and addressed to Advertisement Manager, "Practical Wireless," Tower House, Southampton St., Strand, London, W.C.2.

EDS'S STUDIOS, Chelsea, offers real bargains in new components.—Electrolytic Condensers, 32-16 mfd 350v Hunts All can., 4/6 ea.; 32-32 mfd 350v with fixing base BEC, 4/9; 8-16 mfd Hunts All can., 450v wkg., 5/- ea.; 8-8 mfd 450v wkg., small can. Hunts, 3/- ea.; 12-12 mfd TCC 350v wkg., 2/9 ea., or 2/6 per doz.; 8 mfd Dubilier Drillite 500v tubular, 2/- ea.; 25 mfd 25v Hunts small can., 1/3 ea.; 1/5 mfd 50v TCC with fixing screw, 2/1 ea. Speakers: 8in. ELAC PM less trans., new and boxed, 15/- ea.; 5in. Goodmans, 10/6 ea.; Speaker Transformers, small multi ratio, 4/- ea.; Mains Transformers, new and boxed, pms. 200-220-240v, sec. 350-0-350v 80ma, 4v 5 amp 6-3 4 amp 4-5-2 amp, 17/6 ea., or with 250-0-250 same heaters, 17/6; Small Heater Transformers, 6-3 2 amps 110v 1 amp., 5/9 ea. Special offer: Volume Controls, Centalab with DP switch 3-d meg, spindle 1 1/4in. long, only 2/9 ea., or 2/6 doz. All the Ekco chassis and components previously advertised are still available. Send for new lists. Terms: C.W.O. or C.O.D. over 10/-. **EDS'S STUDIOS**, 255, Fulham Rd., Chelsea, London, S.W.3.

RF UNITS, type 24 or 24 mod. 27 1/6 ea., less valves; 100 new Tubulars, most types assorted, 7/6; 100 Resistors assorted, 10/-; R1124 Receivers for TV sound, with 6-v 13 valves, enough gear to make a mains midget with valves and components to spare, 30/- ea. Meters, moving, coil, 0-20 or 0-40v, 7/6; 0-20 or 0-50 amp, 7/6; 2 1/2in. flush type, 3in. flush, 100ma, 250ma, or 500ma, at 12/6 ea.; all other types in stock. Special offer, soiled VR65s, dirty but O.K., 18/- doz. Chore Horse Petrol Electric Generating Sets, 12-15v 20 amp (300w), runs 15 hrs. or more to the gal.; fully automatic and self-starting; complete with all controls and ready to use, £16/10/- ea.; ex Gov., guaranteed perfect order. Charging and Rectifier Units, 24v 10 amps upwards, from £8/10/-; Radio and Electrical Components of every description in stock, also Optical Goods. Send s.a.e. for our Lists of 1,001 Bargains. Our new booklet, "How to Use ex-Gov. Lenses and Prisms," price 2/6, tells you how to make your own Telescopes, Binoculars, Enlargers, Projectors, Microscopes, Episcopes, etc., and shows you how to get the best results at the cheapest price by using ex-Gov. lenses of the finest quality. All types mentioned are in stock. Lists free. If interested in Stereoscopic Projection with no extra gadgets of any description send s.a.e. for details of our 16mm. Film Loops and Film Strip in colour. Booklet telling all about it, £1/1/-; **H. W. ENGLISH**, Rayleigh Rd., Hutton, Brentwood, Essex.

RADIO SUPPLY CO., 15, Wellington St., Leeds.—W.W. Pots, 20 ohms, 5K, 20K, 50K (standard spindles), 1/11; Co-axial Cable, 1in., 80 ohms, 11d. yd.; ex-E.M.I., 2 gangs, .0005 mfd, 4/9; Dial Bulbs, M.E.S., 6.5v 0.15A, 8v 0.15A, 6/11 doz.; Tubular Condensers (new, not ex-Gov.), 0.001 mfd 750v, 0.01 mfd 750v, 0.05 mfd 350v, 0.1 mfd 350v, 0.25 mfd 350v, 0.02 mfd 1,500v, 3/3 doz. of 1 type; Battery Set Converter Kits, all parts to convert any type of battery receiver to all mains, consist of H.T. trans., L.T. trans., H.T. rect., L.T. rect., H.T. smoothing choke and elects., H.T. dropper resistor, L.T. smoothing choke and elects., and L.T. dropper resistor, circuit supplied, 45/-; H.T. Eliminator and Trickle Charger Kits, consist of H.T. and L.T. trans., H.T. and L.T. rects., smoothing choke, 20-40 mfd elect. and adjust. charger resistor, circuit supplied, 27/6; Battery Charger Kits, consist of mains trans., bridge rectifier and adjust. resistor, to charge 6 or 12v acc. at 3 amps, 27/6, or at 4 1/2 amps, 45/-; C.W.O. or C.O.D. over £1. Post 1/- under £1, 1/6 under £3.

TRANSFORMERS, Mains (salvage), 260-0-260, 6.3v, 3a, tapped for 250, 210, 110v. Price 12/6; post 2/-; also standard O.P. Trans. at 3/9; post 1/-; **DUKE'S**, 621, Rounford Rd., E.12. (Grangewood 6677.)

VALVES

UNIQUE OFFER of new 1.4 volt bat. Valves, ideal for that T.R.F. job. Set of 3 for 12/6, comprising each of 1LW5, 1LD5, 3DG, post free. R. ARMES, 15, Lebanon Gardens, Wandsworth, S.W.18.

"VIEWMASTER" VALVES, as specified, all guaranteed brand new and boxed, comprising 5 EF50, 1 KT61, 1 6P25, 1 EBC33, 1 EB91, 2 6K25, 1 6P28, set of 12, £6/2/6 (postage and insurance 2/-); PL38, PZ30, 18/6; EY51, 14/6; 6P25, 10C1, 6C9, ECH42, X78, 13/6; EF80, DK32, 1A7G, 10P13, 10LD11, 10F9, 6F15, EC91, 12/6; 50L6GT, ECL80, UL41, UF41, UEC41, 1N5, 1H5C, 1C53, 3G5, 10/6; 2526GT, 25Z5, AZ31, 5Z4G, UY41, U404, U09, X61M, 10/-; 6V6GT, KT61, MU1A, 9/6; 1S5, 1R5, 1T4, 3V4, 1S4 8/9; EF91, 6F12, 6AM6, EB91, 8/6; 7Y4, 7C5, 7C6, 7B7, 7H7, 7S7, 7/6; EF39, EF8, EF50, 7/1-; 6K7G, HV2A, 6/3. All new and boxed. Postage, 4d. per valve extra. **READERS RADIO**, 24, Colberg Place, Stamford Hill, London, N.16.

WINWOOD for Value.—New boxed Valves, 1T4, 1S4, 1S5, 1R5, 1H5, 1A7, 1N5, 1C5, 6V6, 6F6, 5Z4, 6X5, EF91, EB91, 9/- ea.; ECH35, 6B8, 12K8, 12C7, 70/- ea. Goodmans's 5in. P.M., 10/9; Plessey 8in., 12/9; 10in. M.E. 1, 250 ohms, w/trans., 26/6; Rola 10in., w/trans., 24/6. 450vV Conds., 8 mfd 2/3, 16 3/-, 8 x 8 3/6, 8 x 16 4/-, 16 x 16 4/3, 32 x 32 6/-; 500vV, 8 mfd 2/6, 16 3/6, 8 x 8 4/-; Semi-midget V/ centrs., L/sp., valves 10K, 25K, 50K, 100K, 1/ 2, 1-meg., 3/6, SP/sw 5/-, DP/sw 5/9, .0003 and .0005 React./Conds., 3/3; Midget .0005, 1/gang, 9/6; .0005, 3-gangs, 5/9. Med./wave Coils, 6/- doz., S/wave, 6/- doz. Droppers, 2 and 3, 3/9 each. Stamp list, 12, Carnarvon Road, Leyton, E.10. (Post only.)

WANTED, Valves, small or large quantities, 6K8, 6V6, 5Z4, 6AC7, 1R5, 1S5, FW4/500, 6Q7, 12K8, 80, VU39, EBC33, 354, etc., etc. Prompt cash. **WM. CARVIS**, 103, North Street, Leeds, 7.

HANNEY OF BATH offers: All components for the "P.W." 3-speed Autogram and Tape Deck Amplifier; send for a detailed parts list now. Acos GP20 Pickups, std. or L.P. 71/5, heads only, 43/4. Acos Crystal Microphones, type Mic. 16-1 and 16-2. £12/12/-; Mic. 22-1 and 22-2. £8/8/-; Mic. 30, £4/4/- W.B. Stentorian Speakers (all 3 ohm speech coil), 24 in. 18/6, 3 in. 19/6, 5 in. 21/-, 6 in. 24/8, 8 in. 32/8, 9 in. 36/9, 10 in. 44/6. Goodman's Speakers (15 ohm) Axion 150, £10/5/6; Audion 60, £8/12/6; Roia G12s, £8/5/- Gram. motors. Decca-BSR 2-speed with turntable. 74/4; ditto 3-speed, type MU14. £7/3/4; Collaro, type 3RC521, auto-changers, 2 GP27 heads, £18/14/8; type 3RC522 (as 522, but mixed) £21/4/3. Output Transformers, Partridge Williamson, £6/19/6; 50-watt, potted for PX4, 6V6, 6L6 and watt. potted for PX4, 6V6, 6L6 and watt. valves, in push-pull, 47/3; Elstone 7-10 watt multiratio, 8/9; ditto 4-watt multiratio, 8/9; supermidget type for personal portables. 4/6; potted mike transformers, 60-1 and 100-1, 9/-; filament trans., 6.3v. 1.5a, 7/6. Coilpacks, Wearite, type 705, 53/4; Osmor Q. type HO, 52/-; H.F. stage for same, 21/8; ETA 4-station tuning unit, 47/4. Coils, Wearite F, 3/- each; Osmor Q, 4/-; Weymouth H, 3/9; Weymouth TR, 10/3 pair; Denco C. type TRF, 8/- pair; RM TRF, 15/- pair. Dials, J.B. full vision, 13/3; J.B. S.L.5, 26/6; J.B. SL8, 27/6; also spare scales for same; Osmor dials, 24/6, escutcheon extra 4/-; Rectifiers, Brimar RM1 4/6, RM2 5/-, RM3 6/-, RM4 18/-, DRM1 10/-, DRM2B 11/-, SB3 10/6; Westinghouse 3EH45 22/6, 3EH750 24/10. Viewmaster: Everything now in stock for all 5 channels; see our advert. in the current issue of PRACTICAL TELEVISION. Sundries: GEC Germanium crystal diodes, 4/- each; Polystyrene varnish, 1/10 large bottle; Solon pencil bit irons, 23/8; Taylor Montrose Multimeters, 50/-; nuts, bolts, washers, etc., etc. Send 6d. stamp for our full lists now. L. F. HANNEY 77, Lower Bristol Rd., Bath. (Tel.: 3811.)

AL. PANELS, 16 gauge, 16in. x 12in., 12in. x 9in., 12in. x 6in., 15in. x 11in., 11in. x 9in., 13in. x 10in., 10in. x 9in. Send S.A.E. WILTON RADIO, 30, Giants Grave Rd., Neath.

G.E.C. Hand Microphones, brand new, 5/6, post free. R.E.P. LTD., 33, Much Park St., Coventry.

DYNAMOS, Motors, Rotary Converters and Amateurs' surplus, from 2/- TOPHAM, 76, Avenue Rd., Saint Neots.

40 GERMANIUM Diode Circuits, 3/2. S.A.E. for lists. Also Components, Valves, etc. WESTWOOD RADIO, Westwoodside, Doncaster.

MAKE YOUR OWN H.T. Batteries cheaply. 12 volt, 8 cell units. 12/- per dozen. EAST'S, 141, Eastcote Rd., Ruislip.

TAPE RECORDINGS, ETC.

THE NEW LINE-A-TONE Tape Recording Panel, no threading of tape; fast forward and rewind, 3 speeds, complete freedom from wow or flutter; in fact this panel embodies all the requirements of the professional recordist. The price still remains at £20. Place your order early. MORECAMBE SOUND SERVICE, "Sealand Works," Cross Cop, Morecambe.

WIRE RECORDER Constructional Details, 1/6; stainless steel Recording Wire, 3,600ft. reels, 5/6. Reduced rates for larger quantities. 12, Rosendale Ave., Blackley, Manchester, 9.

WANTED, Varley 3-gang permeability Tuner, B.P. 100. Must be perfect. H. E. TUPPEN, 255, Malpas Rd., Brockley, S.E.4.

SUMMER SALES.—Rock bottom prices—fast delivery. S.A.E. list. ANNAKIN, 25, Ashfield Place, Outley, Yorks.

SITUATIONS VACANT

The engagement of persons answering these advertisements must be made through a Local Office of the Ministry of Labour or a Scheduled Employment Agency if the applicant is a man aged 18-64, inclusive, or a woman aged 18-59, inclusive, unless he or she, or the employment, is exempted from the provisions of the Notification of Vacancies Order, 1952.

REQD. IMM.—Lab. tech. perm. pensionable, at Norwood Tech. Coll. Knight's Hill, W. Norwood, S.E.27. Telecom. Eng. and Phy. lab. Sal. 69/- wkly. at 16 to 96/- at 19; £270 a yr. at 20; on entry, add £18 for each full year of age above 20, but max. comm. sal. £342. Ann. incs. £18 to £278, and with spec. qualns. to £414. If over 18 apply through emp. exch. or sched. agency. Appl. forms from coll. sec. ret. within 14 days. (664.)

ELECTRONIC TESTERS are required by the Nelson Research Laboratories, English Electric Co. Ltd., Stafford, in their expanding Electronics Laboratories. Applicants should have completed or be completing National Service and preference will be given to young men studying for higher qualifications. There are excellent opportunities for promotion to Laboratory work for the right type of man. Please write, giving full details and quoting reference "ENGLISH ELECTRIC 944," to Westminster Employment Exchange, Chadwick St., London, S.W.1.

OPPORTUNITY IN NEW ZEALAND

Vacancies exist in the Royal New Zealand Air Force for single British ex-Servicemen (age 21 to 40) in the trades of Telegraphist, Wireless Fitter, Wireless Mechanic and Wireless Operator (Ground). Suitable applicants of 30 years of age or under will be considered for trade training in any of the above trades. Excellent rates of pay and conditions offered. For information write to:

R.N.Z.A.F. Headquarters
(Dept. P.W.1.),
Adelphi Building, John Adam Street, London, W.C.2.

EX-W.D. unused Fluorescent Lighting Sets for 12 and 24 volts D.C. input, 230v, A.C. output; Rotary Converter, Choke, P.P. Condenser, Leak Transformer for 85 watt Sodium Lamps; the whole enclosed in metal box; £5 to clear. A. J. PHILPOTT, Fountain Sq., Fenton, Stoke-on-Trent.

WINDCHARGERS.—12v. "Jammelite" Electric Lighting Plant Units, S.A.E. and 24d. stamp for illustrated folder. H. JAMIESON & CO., Mid-laphouse Works, Liskard, Cornwall.

REPAIRS AND REWINDS

VACUUM CLEANERS and Gram. Motors, repairs our speciality. Armature rewinds, new bearings and commutators fitted, also transformers rewound. Competitive prices. Trade enquiries invited. 14 days c.o.d. service. Send s.a.e. for price lists to: A.D.S. CO. (V.E.M. Dept.), 261-3, Lichfield Rd., Aston, Birmingham, 6. Est. 1935.

EDUCATIONAL

FREE! Brochure giving details of Home Study Training in Radio, Television, and all branches of Electronics. Courses for the Hobby Enthusiast or for those aiming at the A.M.Brit.I.R.E., City and Guilds Telecommunications, R.T.E.B., and other Professional examinations. Train with the College operated by Britain's largest Electronic organisation. Moderate fees. Write to E.M.I. INSTITUTES, Postal Division, Dept. PW28, 43, Grove Park Rd., London, W.4. (Associated with H.M.V.)

RADIO OFFICERS urgently reqd. We train most in shortest period. Training fees payable after appointments secured. Scholarships available. Boarders accepted. 2d. stamp for Prospectus. Wireless College, Colwyn Bay.

A.M.I.MECH.E., A.M.Brit.I.R.E., City and Guilds, etc., on "no pass—no fee" terms; over 95% successes. For details of exams. and courses in all branches of engineering, building etc. write for 14-page handbook—free. B.I.E.T. (Dept. 342B), 17, Stratford Place, London, W.1.

MERCHANT NAVY and Air Radio.—Here is an opportunity to train as Radio Officer. The big liners are open to you, but you must qualify for the P.M.G. Certificate. Day, Evening and "Radiocerts" postal courses. Estd. 30 years; s.a.e. for prospectus from Director, THE WIRELESS SCHOOL 21, Manor Gardens, London, N.7. (Tel.: ARC. 3694.)

THE INSTITUTE of Practical Radio Engineers Home Study Courses are suitable coaching text for I.P.R.E. and other qualifying examinations. Fees are moderate. Syllabus of seven modern courses post free from SECRETARY, I.P.R.E., 20, Fairfield Rd., London, N.8.

WORLD TRAVEL and Adventure in the Merchant Navy.—Young men, 15 years upwards, required for training in Marine Wireless and Direction-finding at Sea. (Trainees in forthcoming Registration Groups are eligible for deferment of Military call-up.) Immediate sea-going positions on completion of training. Suitable candidates will be entered as officers and must be prepared to sail to all parts of the world. Low training fees. Send 1/- P.O. for Prospectus to OVERSEAS HOUSE (Dept. P.W.1), Brooks' Bar, Manchester, 16. (Tel. MOSS-side 2047.)

FIRST-CLASS RADIO COURSES . .

GET A CERTIFICATE!

QUALIFY AT HOME—IN SPARE TIME

After brief, intensely interesting study—undertaken at home in your spare time—YOU can secure your professional qualification. Prepare for YOUR share in the post-war boom in Radio. Let us show you how!

FREE GUIDE

The New Free Guide contains 132 pages of information of the greatest importance to those seeking such success-compelling qualifications as A.M.Brit.I.R.E., City and Guilds Final Radio, P.M.G. Radio Amateurs, Exams., Gen. Cert. of Educ., London B.Sc. (Eng.), A.M.I.P.E., A.M.I.Mech.E., Draughtsmanship (all branches), etc., together with particulars of our remarkable Guarantee of

SUCCESS OR NO FEE

Write now for your copy of this invaluable publication. It may well prove to be the turning point in your career.

FOUNDED 1885—OVER 150,000 SUCCESSES

NATIONAL INSTITUTE OF ENGINEERING

(Dept. 461), 148, HOLBORN, LONDON, E.C.1

MORSE CODE Training

Send for the Candler

BOOK OF FACTS

It gives details of all Courses available

CANDLER SYSTEM CO. Dept. 5L0
52B, Abingdon Road, London, W.8
Candler System Co., Denver, Colorado, U.S.A.

TRANSFORMERS

- No. 1. 250-0-250v. 80 ma. 0-4v. 5a., 6.3v. 3.5a., 0-4.5v. 2a. 17/-.
- No. 2. As No. 1 but 350-0-350v., 17/-.
- No. 3. 25v. 2.5a. tapped to give almost any voltage up to 25v. Ideal for chargers, models, W.D. motors, etc., 16/6.



- No. 4. 4v., 9v., 20v. 4 amp. For 2, 6 and 12 volt chargers, 16/-.

- No. 5. Auto wound, 10-0-110-200-230-250v. 150 watts. For general voltage changing up or down. 16/6.

- No. 6. 250-0-250v. 100 ma., 0.3v. 3.5a., 5v. 2a., 22/-.
- No. 7. Television Auto with overwind. 0-200-230-250-280v. 500 ma., 6.3v. 7a., 0-2-6.3v. 2a. 38/6.

Viewmaster Type. 6.3v. 7a., 0-2-6.3v. 2a. 35/-.

All types upright or drop through. No others available. Primaries on 1, 2, 4 and 6 tapped 200-230-250v. Intertwined, impregnated, Screened, Guaranteed.

Terms: C.W.O., C.O.D. or pro forma. Postage 1/6 1 to 3

HILLFIELDS RADIO,
8, BURNHAM ROAD,
WHITLEY, COVENTRY

CLASSIFIED ADVERTISEMENTS

(Continued from page 439)

DISTINCTIVE DUPLICATING! Attractive work: materials: lowest cost: 100. 8in. x 10in., 7/7; 1,000. 33/-; delivered 48 hours: discounts quantities. Lists. "SPEEDWELL" (D5), Albert St., Lockwood, Huddersfield.
WALNUT Radiogram Cabinets. Stamp details. E. WISKER, 501, Hale End Rd., Highams Park, E.4.

SERVICE SHEETS for hire. Reasonable terms. S.A.E. for particulars to W. J. HERBERT, 118, Gelli Rd., Gelli Pentre, Rhondda, Glam.

WALNUT Radiogram Cabinets of distinction, stamp details. R. SHAW, 69, Fairlop Rd., E.11.

COILS

For Summer All Dry Portable (June, 1951 P.W.), 4/3; also Circuit for Simple A.D. 2-Valve Receiver, Dual Wave Coil with 1 Valve, 2 Valve, and Crystal Receiver Circuits, 4/3. TRF Coils, AD3 Band 3 (Aug. P.W.), 6/6 pr. 1FTS Min. Coil Packs, Viewmaster Coils, etc., at very competitive prices. Trade supplied.

T. G. HOWELL,
29, McWilliam Rd., Brighton, 7.



???'HOWSIT DUN'???

A.C. MAINS GRAMOPHONE AMPLIFIER KIT

Complete kit of parts, incl. Dia-gram, Data, Valve & Speaker 57/6 post free. (Wired and Tested 13/- extra)

GUARANTEED NEW BOXED VALVES
G.T.1, 154, 155, VU39, 35L6, 35Z4, 1R5, 1H5, 1N5, KT63, X63, X65, 1A7, 1C5, 5Z4, 6SL7, 6SN7, EF50, 5U4, 6X5, 6V6, EF80, EBC33, W21, 6F6, EB91, EF91, KT61, 6Q7, 5Y3, U50, 12K7, 93, Post Free.

SPECIAL: 6K7 Metal. Soiled, Tested, Four, for 12/6 Post Free.

Catalogue, Circuits, Data, 1/- Post Free. Only Address:
Elm Road, London, E.17.
Phone: KEY 4813



For high and low voltage testing:—1-30 and 100-950 volts A.C. or D.C. Write for interesting leaflet 29F.



CONDENSERS
1+1.1 Mfd. 250 Volt, 6d. ea.
50 Mfd. 6 Volt, 6d. ea.
25 Pf. Twin Gang, 2/- ea.
.01 Mfd. 350 Volt, Tubular, 4d. ea.
.60 Mfd. 12 Volt, 1/- ea.
100 Pf. Variable, 2/- ea.
.01 Mfd. Mica, 500 Volt, 4d. ea.
.05 Mfd. 300 Volt, 6d. ea.

SPEAKERS P.M.
5in. Goodmans, 13/6 ea.
8in. Goodmans, 16/6 ea.
6in. Elac, 14/6 ea.
Microphones, P.O. Insert (Carbon), 1/9 ea.
Orders under £2, add 1/3 post. Over, free. Stamp for Lists.
Tel.: St. Albans 5951.

BOLD & BURROWS,
12/18 VERULAM ROAD (A5),
ST. ALBANS. HERTS.

L.R.S. NEW EASY TERMS!

Prompt and Efficient Service.
In stock for immediate delivery.

LOUDSPEAKERS
Audiom 60. Cash £8.12.6 or 30/- with order and 8 monthly instalments of 20/-.
Axiom 150 Mk.II. Cash £10.5.6, or 35/- with order and 9 monthly instalments of 20/-.
WB 10in. Concentric Duplex. Cash £7.15.0, or 25/- with order and 7 monthly instalments of 20/-.

14 FREE SHAVES with the AMAZING NEW REMINGTON Contour 6 ELECTRIC SHAVER will convince you that there is nothing to equal it for speed, comfort and efficiency.

14 days FREE TRIAL available on receipt of 20/- deposit (returnable if not entirely satisfied). Balance 8 monthly instalments of 21/- Cash £8.19.5.

All above Carriage and Packing paid. Leaflets available on request.

The LONDON RADIO SUPPLY COMPANY, LIMITED.
BALCOMBE, SUSSEX
Estab. 1925. Telephone: Balcombe 254

Amateur Radio Enthusiasts THE INCOMPARABLE GLOBE-KING
SINGLE VALVE S.W. RECEIVER
● WORLD-WIDE RANGE 11-100 METRES ● CRYSTAL-CLEAR NOISE-FREE RECEPTION ● ELECTRICAL BAND-SPREAD TUNING ● EXTREMELY LOW RUNNING COSTS
Catalogue Free. Stamp for postage.
JOHNSONS (RADIO)
46, FRIAR STREET, WORCESTER

SPARKS' DATA SHEETS

Guaranteed and Tested Radio Designs THE "GIUMMY" PORTABLE—An All-dry 2-Valve which does give good Phone sigs, on Med. and Long waves. Self-contained aerial and batteries. Tested in Dorset 70 miles from nearest Regional Station and 115 miles from Droitwich. Size approx. 8in. x 4 1/2in. x 2 1/2in. Data Sheet, 3/21. Post Paid.
THE "MIDDY" A 2-Valve which gives amazing results on Med. and Long waves and "Ship-to-Shore" transmissions when used with a short aerial. Good Speaker results. All-dry 12 tubes. The Ideal Set for the Beside, Caravans, The Den and Yachts. Dorset tested. D Sheet, 3/21. Post Paid.
THE "ENTERPRISE" A Very Efficient 3-Valve Plus Rect. TRF Med-Long-wave Receiver for A.C. Mains. 41 Watts of Quality on Radio and P.U. External or Mains Aerial. A Fine, Economical Set for the Home. D/Sheet, etc., 3/21. Post Paid.
THE "ENSIGN" Good Quality from the "Local" Stations in areas where high selectivity is not essential. Plus good P.U. reproduction. 41 Watts Output. Med/Long waves. Valves 6J7, 6V6 Plus Rect. Easy to Build. D/Sheet, etc., 3/21. Post Paid.
Many other Designs Available.

STAMP FOR LIST COMPONENTS SUPPLIED
L. ORMOND SPARKS (P),
48A, HIGH STREET, SWANAGE,
DORSET

Practical Wireless BLUEPRINT SERVICE

PRACTICAL WIRELESS

No. of
Blueprint

CRYSTAL SETS

- 1s. each.
1937 Crystal Receiver .. PW71*
The "Junior" Crystal
Set PW94*

STRAIGHT SETS

Battery Operated

- One-Valve : 2s. each.
The "Pyramid" One-
valver (HF Pen) .. PW93*
Two-valve : 2s. each.
The Signet Two (D &
LF) PW76*
Three-valve : 2s. each.
Summit Three (HF Pen,
D, Pen) PW37*
The "Rapid" Straight
3 (D, 2 LF (RC &
Trans)) PW82*
F. J. Camm's "Sprite"
Three (HF Pen, D,
Tel) PW87*
Four-valve : 2s. each.
Fury Four Super (SG,
SG, D, Pen) PW34C*

Mains Operated

- Two-valve: 2s. each.
Selectone A.C. Radio-
gram Two (D, Pow) PW19*
Three-valve : 2s. each.
Double - Diode - Triode
Three (HF Pen, DDT,
Pen) PW23*
Four-valve : 2s. each.
A.C. Fury Four (SG, SG,
D, Pen) PW20*
A.C. Hall-Mark (HF
Pen, D, Push-Pull) .. PW45*

SUPERHETS

- Battery Sets : 2s. each.
F. J. Camm's 2-valve
Superhet PW52*

No. of
Blueprint

SHORT-WAVE SETS

Battery Operated

- One-valve : 2s. each.
Simple S.W. One-valver PW88*
Two-valve : 2s. each.
Midget Short-wave Two
(D, Pen) PW38A*
Three-valve : 2s. each.
Experimenter's Short-
wave Three (SG, D,
Pow) PW30A*
The Perfect 3 (D, 2 LF
(RC and Trans)) .. PW63*
The Band-spread S.W.
Three (HF Pen, D
(Pen), Pen) PW68*

PORTABLES

- Four-valve : 2s.
"Imp" Portable 4 (D,
LF, LF, Pen) PW86*
1s.
The "Mini-Four" All-
dry (4 valve superhet) PW

MISCELLANEOUS

- 2s. each.
S.W. Converter-Adapter
(1 valve) PW48A*
(2 sheets), 7s. 6d.
The P.W. 3-speed Auto-
gram.

TELEVISION

- The Practical Television Receiver,
(3 sheets) 10/6
The "Argus" (6in. C.R. Tube) 2/6

AMATEUR WIRELESS AND WIRELESS MAGAZINE

STRAIGHT SETS

Battery Operated

- One-valve : 2s.
B.B.C. Special One-
valver AW387*
Two-valve : 2s. each.
A modern Two-valver .. WM405*

Mains Operated

- Two-valve : 2s. each.
Consoelectric Two (D,
Pen), A.C. AW403

SPECIAL NOTICE

THESE blueprints are drawn full size. The issues containing descriptions of these sets are now out of print, but an asterisk beside the blueprint number denotes that constructional details are available, free with the blueprint.
The index letters which precede the Blueprint Number indicate the periodical in which the description appears: Thus P.W. refers to PRACTICAL WIRELESS, A.W. to Amateur Wireless, W.M. to Wireless Magazine.
Send (preferably) a postal order to cover the cost of the Blueprint (stamps over 6d. unacceptable) to PRACTICAL WIRELESS Blueprint Dept., George Newnes, Ltd., Tower House, Southampton Street, Strand, W.C.2.

No. of
Blueprint

SHORT-WAVE SETS

Battery Operated

- One-valve : 2s. each.
S.W. One-valver for
America AW425*
Two-valve : 2s. each.
Ultra-short Battery Two
(SG, det Pen) WM402*
Four-valve : 3s. each.
A.W. Short Wave World-
beater (HF Pen, D, RC,
Trans) AW436*
Standard Four-valver
Short-waver (SG, D,
LF, P) WM383*

Mains Operated

- Four-valve : 3s.
Standard Four-valve A.C.
Short-waver (SG, D,
RC, Trans) WM391*

MISCELLANEOUS

- Enthusiast's Power Am-
plifier (10 Watts) (3/-) WM387*
Listener's 5-watt A.C.
Amplifier (3/-) .. WM392*
Harris Electrogram
Battery Amplifier (2/-) WM395*
De Luxe Concert A.C.
Electrogram (2/-) .. WM403*

HINTS COUPON

This coupon is available until Sept. 1st, 1952, and must accompany all Practical Hints.
PRACTICAL WIRELESS, Sept., 1952.

Published on the 7th of each month by GEORGE NEWNES, LIMITED, Tower House, Southampton Street, Strand, London, W.C.2. and printed in England by W. SPEARHEAD & SONS, LTD., Exmoor Street, London, W.10. Sole Agents for Australia and New Zealand: GORDON & GOTCH (A/sia), LTD, South Africa: CENTRAL NEWS AGENCY, LTD. Subscription rate including postage, for one year: Inland and Abroad 13s. 6d. (Canada 13s.). Registered at the General Post Office for the Canadian Magazine Post.

LASKY'S RADIO

METAL RECTIFIERS
6 volts 4 amps. LASKY'S PRICE, 17/6.
12 volts 4 amps. LASKY'S PRICE, 17/6.

I.F. TRANSFORMERS
465 kc/s. Iron dust cores, complete in screening-can, size 9 1/2 in. high, 1 1/2 in. square.
LASKY'S PRICE, 6/9 per pair.

25 WATT AMPLIFIERS.
By Romac.

BRAND NEW AND UNUSED
For use on 200-250 volts. A.C. Mains. Supplied complete with all valves. 2 6L8's in push-pull, also a loud and absolute wave radio tuner unit. Absolutely perfect, ready for operation.
LASKY'S PRICE, 22/5. Carriage and packing 25/- extra.

2 VOLT BATTERY VALVES

KT2 3/6
HL2 4/6
Postage 6d. per valve extra.

INCOMPLETE INTERCOM MASTER UNIT CHASSIS

Contains 16+16 mfd. 450 v.w. condenser, 2 Yaxley switches, valveholders, input and output transformers, etc. Less valves and S/R switch.
LASKY'S PRICE, 15/- each.
Carriage 2/6 extra.

CABINETS FOR INTERCOM UNITS
LASKY'S PRICE, 18/6 each.
Carriage 2/6 extra.

EXTENSION SPEAKER CABINETS
For use with 3in. speaker. LASKY'S PRICE, 9/11 each. carriage 2/- extra.

FOR CALLERS ONLY. RECEIVER TYPE S/LC. No. 4

Built on strong metal chassis: 20 x 8 x 8 1/2 in. Contains 11 valves: 2 EF50; 4 5P61; 2 6P1; 2 VR32; 1 PEN46. Also 13.5 mc/s I.F. Strip. Hundreds of other components, including resistances, condensers, coils, etc.
LASKY'S PRICE, 25/-.

EX. A.M. RECEIVER TYPE RL155. BRAND NEW AND UNUSED. IN WOOD TRANSIT CASE.

Supplied complete with 10 valves. Aerial tested before despatch. Circuit: B.F.O., A.V.C., R.F. Amp. two I.F. Stages, magic eye, etc., etc. 5 Frequency ranges: 18.5-7.5 mc/s; 7.5-3.0 mc/s; 1,500-600 kc/s; 500-200 kc/s; 200-75 kc/s. Full modification and circuit details supplied.
LASKY'S PRICE, £12 19/6. Carriage 7/6 extra.
POWER PACK AND OUTPUT STAGE FOR THE RL155. Supplied fully wired and assembled, with rectifier and output valve. Ready for use on A.C. Mains 200-250 volts. LASKY'S PRICE, 79/6 if purchased with RL155 Receiver. Otherwise 99/6, carriage 5/- extra.

SPECIAL COIL BUY SUPERHET COILS. For 465 kc/s.

I.F.
No. 1. Dual wave, medium and long. Aerial and oscillator. Supplied with circuit. Size of each coil: 1 1/2 in. high, 1 in. diameter.
LASKY'S PRICE, 2/11 per pair.
Post 9d. extra.
No. 2. For short wave, 25-65 metres. Aerial and oscillator. Supplied with circuit diagram. Size of each coil: 1 1/2 in. high, 1 in. diameter.
LASKY'S PRICE, 1/11 per pair.
Post 9d. extra.

SOLON HENLY SOLDERING IRONS. Complete with mains lead. Oval bit.
LASKY'S PRICE, 19/-. Postage 1/6 extra.

COIL PACKS

No. 1. 3 Wavebands, 12-35 metres; 35-100 metres; 200-550 metres. 1 1/2 in. spindle. long wavechange switch. Completely assembled and wired. Size: 4 in. x 4 in. x 3 in. BRAND NEW.
LASKY'S PRICE, 16/-
Postage 1/- extra.

CAR RADIOS. By Romac. BRAND NEW AND UNUSED. 12 Volt. 6 Valves, including R.F. amplifier, L. and M. Wavebands. Perfect working order ready for installation.
Listed at £33. LASKY'S PRICE, £15 19/6.
Complete with all valves. Carriage 10/- extra.

LASKY'S RADIO

LASKY'S (HARROW ROAD), LTD.,
370, HARROW ROAD, PADDINGTON, LONDON, W.9.

Telephones: CUNningham 1979-7214.

Hours: Mon. to Sat., 9.30 a.m. to 6 p.m.; Thurs. half day, 1 p.m. Postage and packing charges (unless otherwise stated); on orders value £1—1s. 0d. extra; £5—2s. 0d. extra; £10—3s. 6d. extra; over £10 carriage free. All goods fully insured in transit.

T.C.C. VISCONOL HIGH VOLTAGE CONDENSERS

04 mfd., 12.5 Kv., 7/6.
Electrolytic 32 + 100 mfd., 450 v.w. T.C.C. Type CE10PE. 7/6. Postage extra.

024	8/-	6K9M	13/-	18K7	9/-
1A5GT	8/6	016	11/6	18D2	4/8
1C5GT	8/6	G17	8/6	25A6G	9/6
106GT	7/6	6N7	7/6	32ZGT	9/6
114	8/-	6N7GT	7/6	33LGT	10/-
11L03	6/9	6Q7G	11/6	50L9GT	10/-
1R3	9/6	6R7	8/-	AC1P8	7/9
184	9/-	68A7GT	9/6	CH435	14/6
185	9/6	68Q7	7/6	CV139	(£139)
1T4	9/6	68J7	7/-	CV6	3/9
1U5	10/6	68J7	9/6	MKT4	10/6
2A3	7/9	68K7	7/-	CV135	9/-
2153Q	4/-	68L7	9/6	CRP72	4/-
2K3	6/8	68N7GT	11/6	DD13	7/6
3A4	9/-	68Q7	9/6	DD73M	10/-
3D6	9/6	6C36	9/6	DD77	(6A76)
3Q4	9/6	6V6G	10/6	DL43	8/-
384	10/6	6V6GT	10/6	ELC41	11/6
3V4	9/6	6V6	8/-	ECL80	12/6
4D1	4/9	6X5GT	8/8	ECL84	12/6
4L2	9/6	6Z6	8/-	ECL86	12/6
5B4	9/-	6AM6	11/6	EL41	11/6

VALVES GUARANTEED NEW & BOXED

5H4C	9/-	6A15	9/-	PW4500	9/9
6K5G	9/6	7B6	9/-	G6Z5	4/6
6Y3GT	9/6	7H7	9/-	HL123DD	8/6
5Z4G	10/6	7B9	9/-	HP210	8/-
5Z4M	9/6	7C5	9/-	KT30	11/-
6A7	7/6	7C8	9/-	KT32	10/-
6B4	3/6	7D7	9/-	KT38C	11/6
6R8	7/9	7R7	9/-	KT61	10/6
6C5GT	7/6	7Y4	9/-	KT66	11/6
6C6	7/6	7T7	7/9	KT81	11/6
6C8	9/-	7B	8/-	KTW61	8/9
6D4	7/6	80	9/6	KTW63	7/9
6F6G	9/-	807	10/6	KTZ41	6/9
6F6M	9/6	8D2	4/9	KTZ63	7/9
Pen A4	11/-	954	2/9	MH4	8/-
6F8G	9/-	955	5/9	OK7G	6/6
608G	7/6	956	3/2	OK7GT	6/6
6H6	4/6	912	4/9	2B6	7/9
6J5G	5/6	9063	6/8	U78	9/-
6J5GT	5/6	12A6	7/9	MS/PEN	5/-
6J7M	8/6	12C8	9/6	GB6Q	12/6
6J7G	6/9	12K8	9/6	NT40	11/6
6K5GT	8/6	1283T	7/9	NT40	11/6
6K8G	12/6	11L45	2/-	PEN25	8/6

ALPHA RADIO SUPPLY CO.

MIDGET OUTPUT TRANSFORMER

For Personal Sets, 4/3 each; A.W.F. Power Pentode, 4/- each; Midget I.F. Trans., Weatite 4306, 456/475 kc/s, 10/8 pair.

WIRE WOUND CONTROLS

5Ω, 200Ω, 5 kΩ, 10 kΩ, 20 kΩ, 25 kΩ, 50 kΩ, 2/9 each.

METAL RECTIFIERS

1 wave, 250v, 45 mA., 6/9 each; Bridge, 12v, 5 amp., 18/6 each; 12v, 1 amp., 4/8 each.

MAINS TRANSFORMERS

3-way Mounting Type. Primary 200-220-240v. Secondary, 250-0-250v., 80 mA., 0-4v., 5 amp.; 0-6.3v., 4 amp.; 0-35v., 2 amp., 16/- each. As above, with 250-0-250v. H.T. secondary, 16/- each. Ex-Govt. Equip., 350-0-350v., 80 mA., 2-4.3v. Windings and 5v.-Tapped. Primary, Surface Mounting, Wax Dipped, 25/6 each. Postage on Transformers, 1/6 each.

ENGRAVED KNOBS

1 1/2 in. dia. for 4 in. spindles, available Cream or Brown as follows: "Focus," "Contrast," "Brilliance," "Brightness," "Brilliance On/Off," "Wave-change," "On/Off," "Tuning," "Volume," "S.M.L. Gram," "Tone," "Vol. On/Off," "Radio-gram," "Bass," "Trebble," "Record-Play." Also Plain Knobs to match, 1/6 each.

ENAMELLED COPPER WIRE

1 1/2 reels, 14 S.W.G., 1/9 each; 1 1/2 reels, 16 S.W.G., 1/9 each.

CLIX SPADE TERMINALS

Red and Black, 3d. each.

PEN46	8/6	VU133	4/-	BARRETTET	
PEN20A	5/6	30GT	9/-	161	7/6
PL82	12/6	X78	9/-	150A	7/6
PM2A	4/9	12A7	10/6	U403	9/-
PM1HF	4/9	6A7	10/6	UDT19	7/6
PM205	4/9	6BE9	10/6	UG6	9/-
PEN43DD	6/9	68A7	9/-	TH4	10/6
	10/-	U76	9/-	TH300	10/-
RKR72	4/-	2013C	6/2	TR13	13/-
TP25	9/6	35A5	9/6	QP22B	12/6
U30	8/6	35Z3	9/6	EP80	12/6
UCH42	12/6	6A5	9/-	ECH42	12/6
UL41	11/6	6A5K5	9/-	UCH42	13/6
UY41	10/6	6B6A	9/-	EAF42	11/6
VR33	7/6	PEN383	12/-	ERF80	11/6
VR54	4/-	UR3C	9/6	FL35	10/6
VR55	6/-	AZ31	9/-	UB41	9/-
VR56	7/6	U31	9/-	UL46	12/6
VR57	8/-	UY91	9/-	EZ35	9/-
VR65	4/-	BL63	7/-	EL42	11/6
VR65A	4/-	6C4	8/8	UL44	15/-
VR91	6/6	4U7	9/-	UF41	10/6

VALVES MAJORITY IN MAKERS' CARTONS

EF50	Sylvania	TP2620	12/-	128GT	9/-
		EBC3	8/6	7193	3/6
EA50	2/6	TSP4	8/-	65M	5/6
VR119	4/6	6C10	12/6	10L1D11	10/6
VE78	7/6	6C9	12/6	10C1	11/6
VR135	6/-	6D3	12/6	10F9	13/6
VR137	5/9	6L18	10/6	10F13	12/6
VT52	8/-	20P2	13/6	10L1D11	11/6
VP23	8/6	6F14	13/6	VT61	7/6
VP41	8/-	1P2	10/6	21D4	7/6
VP39	9/6	10P1	13/6	EP13A	10/6
VU111	4/6	6L290	10/6	BOH21	9/6
VU120A	4/6	6D5	10/6	HL42DD	11/6
VM84B	11/6	20D1	9/-	HL133DD	9/6
VS70	3/9	6P15	13/6	ME41	9/-
W21	4/9	1P11	10/6	TH2321	10/6
W77	9/-	U401	9/-	HP4301	10/-
X18	10/-	10F13	9/6	HP4106	10/6
X61	11/6	10P3	15/-	PEN DD2530	8/6
Y63	9/-	6119	14/6	QP25	8/6
VR150/30	9/6	20L1	14/6	GY60	7/6
VS68	4/-	6F12	11/6	KT8	9/6
TP22	12/6	6D2	9/-	68T7	9/-
HL23	6/6	6A5	9/-		

TERMS: Cash with order or C.O.D. MAIL ORDER ONLY. Full List available; send 3d. stamps. Postage, 6d. under 10/-, 1/- under 20/-, 1/6 under 40/-

5/6 VINCES CHAMBERS, VICTORIA SQUARE, LEEDS, 1