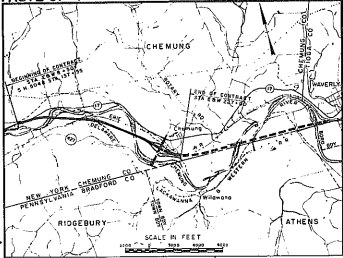


FASTE 67-4

FASTE 67-4



SITE OF WORK

PLANS FOR CONSTRUCTING WITH FEDERAL AID, THE SOUTHERN TIER EXPRESSWAY (Lowman - Waverly, Part I) From Station 8+50 to Station 227+00, a length of 4.14 miles (Plus 0.41 miles of Access) in the Town of Chemung

200 SHEETS

CHEMUNG COUNTY

CONTRACT NO. F.A.S.T.E. 67-4

CONTRACTOR'S NAME: THE HURKIN-CONKEY CONSTRUCTION COMPANY

DATE OF AWARD: September 18, 1967

COMPLETION DATE: December 1st, 1970

DATE OF FINAL ACCEPTANCE: 1-27-71

FISCAL SHARE COSTS: (1) \$1,768,725.45

(2) \$2,203,640

(3) \$2,377,644

COMBINED TOTAL COST \$1,879,307.69

DISTRICT ENGINEER - L.W. HALLENBECK

Regional Director, Region No. 6

ENGINEER IN CHARGE: P.A. FLAHEE

FED. ROAD DIST. NO.	STATE	FED. AID PROJ. NO.	SHEET NO.	TOTAL SHEETS
1	N.Y.	APD-221(21)	1R	247

SOUTHERN TIER EXPRESSWAY SECTION 6R LOWMAN - WAVERLY PART I CHEMUNG COUNTY

TYPE OF CONSTRUCTION		
Cement Concrete Pavement		4.01 Miles
Miscellaneous Work		0.13 Miles
Access		1.14 Miles
Canal Concrete Pavement		4.65 Miles
Asphalt Concrete, Type 1A		0.68 Miles
Graded Gravel		

Including:

- Bridge No. 1, Eastbound Expwy. over Chemung River, 7 Span Comp. Girder, 820' Total Length
- Bridge No. 1, Westbound Expwy. over Chemung River, 7 Span Comp. Girder, 820' Total Length
- R.E.C.S. and Bridge No. 2, Eastbound Expwy. over Erie-Lackawanna Railroad and Parshall's Cove, 8 Span Comp. Girder, 915' Total Length
- R.E.C.S. and Bridge No. 2, Westbound Expwy. over the Erie-Lackawanna Railroad and Parshall's Cove, 9 Span Comp. Girder, 1114' Total Length
- Bridge No. 3, Eastbound Expwy. over Chemung River, 7 Span Comp. Girder, 820' Total Length
- Bridge No. 3, Westbound Expwy. over Chemung River, 7 Span Comp. Girder, 820' Total Length
- H.O.S. Bridge No. 4, County Road 9 over Expwy., 2 Span Comp. Girder, 225' Total Length
- R.E.C.S. Bridge No. 8, County Road 9 over Erie-Lackawanna Railroad, 3 Span Comp. Girder, 166' Total Length

Bridge No. 9-1, County Road 9 over Chemung River, 7 Span Comp. Girder, 820' Total Length

Improvement and Rehabilitation of the Channel of the Chemung River for a Total Length of 1.91 Miles

STANDARD STRUCTURE SHEETS

53-34, 58-60, 51-72(2), 61-71, 65-6, 62-6, 65-60, 63-3, 63-3A, 63-91B, 63-11W, 63-43, 64-19, 64-19A, 64-2, 64-25, 64-25A, 64-25B, 64-25C, 64-25D, 65-1, 65-102, 65-105, 65-22B, 66-11C, 66-11D, 66-15, 66-17A, 66-43(2), 66-43(2), 66-43(2), 66-49B, 66-53, 66-61, 67-42(2), 67-42C

All work contemplated under this contract to be covered by and in conformity with the specifications adopted January 2, 1962 as amended by Addendum No. 1, Item No. 39, except as modified on these plans and in the Itemized Proposal.

RECOMMENDED BY: *[Signature]* DATE: April 19, 1969
W. J. DENNIS, DISTRICT ENGINEER

APPROVED BY: *[Signature]* DATE: 6-2-69
HUL BURTH, ASSISTANT CHIEF ENGINEER, HIGHWAYS

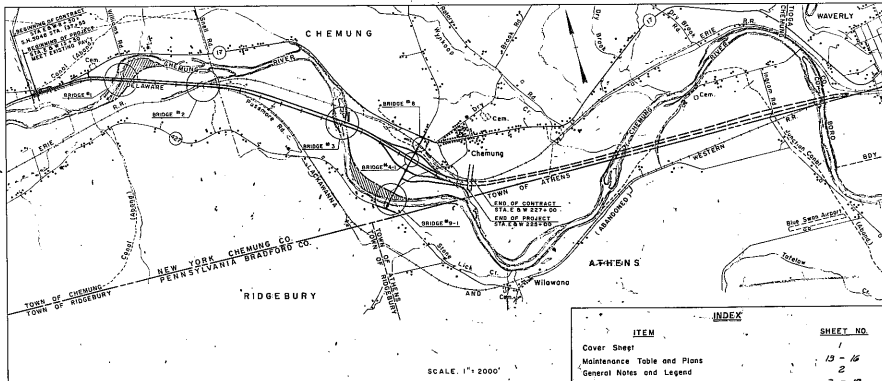
[Signature] DATE: June 2, 1969
V. J. BURNS, DEPUTY CHIEF ENGINEER, BRIDGES

[Signature] DATE: June 2, 1967
ROBERT W. SHEET, CHIEF ENGINEER

DEPARTMENT OF TRANSPORTATION
BUREAU OF PUBLIC ROADS

APPROVED: _____ DATE: _____
DIVISION ENGINEER

RECORD PLANS



DESIGN TRAFFIC DATA

Design Class	Rural Class	2	Mod
Estimated 1973 Traffic	D.H.	1100	
	A.A.D.T.	14100	
Estimated 1990 Traffic	D.H.	1910	
	A.A.D.T.	25300	

INDEX

ITEM	SHEET NO.
Cover Sheet	1
Maintenance Table and Plans	13 - 16
General Notes and Legend	2
Typical Sections	3 - 12
Grade and Elevation	13 - 20
Summary of Highway Quantities	21 - 26
Resurfacing S.H. 5016	27 - 35
Tables	36 - 37
200' Scale Location Plans	38
Drainage Details	39 - 41
Roadside Development Sheet	42
Suggested Maintenance of Traffic Plan	43-44
50' Scale Plans	45 - 49
Bridge	50 - 199

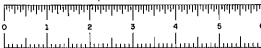
NOTE: THESE RECORD PRINTS HAVE BEEN REVISED TO SHOW REPAIR WORK DONE FOLLOWING THE FLOOD OF JUNE 1972. THE FOLLOWING SHEETS HAVE BEEN REVISED: 39 F1R1, 40 F1R1, 42 R1, 42 G1, 43 R1, 54 R1, 55 R1, 58 R1, 63 R1, 64 R1, 71 R1, AND 73 R1. FOR ADDITIONAL REPAIR WORK ON BRIDGES SEE RECORD PRINTS ON: EMERGENCY REPAIR CONTRACT, LOWMAN TO WAVERLY PARTS 1 & 2, CHEMUNG COUNTY, PIN 6700.05.321.

PREPARED BY:
GOODKIND & O'DEA
CONSULTING ENGINEERS
NEW YORK, NEW YORK

[Signature]
WILSON B. WITTELL
LICENSE NO. 29962

FASTE 67-4

FASTE 67-4



FED. ROAD DIST. NO.	STATE	FED. AID PROJ. NO.	FISCAL YEAR	SHEET NO.	TOTAL SHEETS
1	N.Y.	APD 221(421)	2	200	

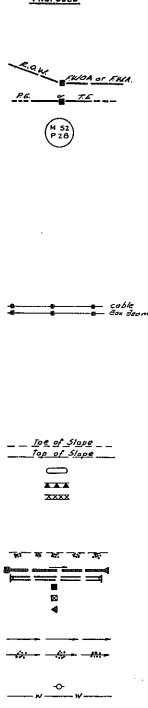
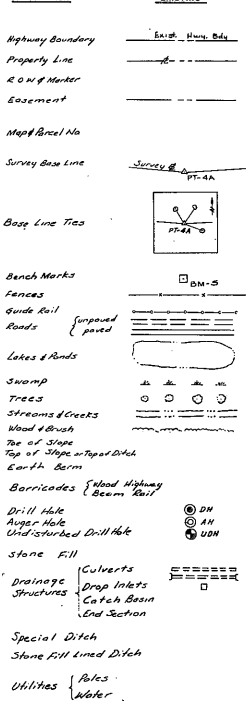
SOUTHERN TIER EXPRESSWAY SECTION 6R
107MAN - WAVERLY PART I
CHEMUNG COUNTY

TYPICAL SECTION STATION LIMITS		
STATION TO STATION	SECTION	CONDITION
MAINLINE		
EASTBOUND		
E59+50 - E29+75	T-1A	Normal
E29+75 - E32+75	T-1B	Transition
E32+75 - E45+75	T-1B	Bank Rt. 1/2"/ft.
E45+75 - E48+75	T-1B	Transition
E48+75 - E51+10.66.60	T-2A	Normal
E51+10.66 - E59+12.86	Br Bridge	Normal
E59+12.86 - E86+01.42	T-2A	Normal
E86+01.42 - E95+16.39	Br Bridge	Normal
E95+16.39 - E95+25	T-2A	Normal
E95+25 - E99+00	T-2B	Transition
E99+00 - E112+75	T-2B	Bank Rt. 3/8"/ft.
E112+75 - E116+50	T-2B	Transition
E116+50 - E155+09.79	T-2A	Normal
E155+09.79 - E163+92.21	Br Bridge	Normal
E163+92.21 - E164+25	T-2A	Normal
E164+25 - E168+25	T-2B	Transition
E168+25 - E182+50	T-2B	Bank Rt. 1/4"/ft.
E182+50 - E186+50	T-2B	Transition
E186+50 - E208+25	T-2A	Normal
E208+25 - E211+25	T-2B	Transition
E211+25 - E225+00	T-2B	Bank Lt. 1/2"/ft.
WESTBOUND		
W6+00 - W31+00	T-1A	Normal
W31+00 - W34+00	T-1B	Transition
W34+00 - W37+00	T-1B	Bank Rt. 1/2"/ft.
W37+00 - W50+00	T-1B	Transition
W50+00 - W51+71.87	T-2A	Normal
W51+71.87 - W59+75.13	Br Bridge	Normal
W59+75.13 - W81+58.75	T-2A	Normal
W81+58.75 - W89+71.72	Br Bridge	Normal
W89+71.72 - W89+75	T-2A	Normal
W89+75 - W102+50	T-2B	Transition
W102+50 - W116+00	T-2B	Bank Rt. 3/8"/ft.
W116+00 - W119+75	T-2B	Transition
W119+75 - W155+72.52	T-2A	Normal
W155+72.52 - W163+74.93	Br Bridge	Normal
W163+74.93 - W164+00	T-2A	Normal
W164+00 - W166+50	T-2B	Transition
W166+50 - W177+50	T-2B	Bank Rt. 3/8"/ft.
W177+50 - W181+25	T-2B	Transition
W181+25 - W206+75	T-2A	Normal
W206+75 - W209+75	T-2B	Transition
W209+75 - W225+00	T-2B	Bank Lt. 1/2"/ft.

MEDIAN WIDTHS		
STATION TO STATION	MEDIAN WIDTH	
E6+50 - E32+14.00	26'	
E32+14.00 - E47+36.72	26' to 72'	
E47+36.72 - E98+05.67	72'	
E98+05.67 - E116+16.97	72' to 150'	
E116+16.97 - E165+12.59	150'	
E165+12.59 - E183+16.61	150' to 72'	
E183+16.61 - E208+16.10	72'	
E208+16.10 - E225+00	72' to 150'	

Notes: Sta. W21+25 - W29+50
Modifying Median Section to
accommodate Box-Beam
Median Barrier.

LEGEND



- ABBREVIATIONS**
- EL or Elev. Elevation
 - Inv. Invert
 - Ed. Edge
 - Prop. Proposed
 - TGL Theoretical Grade Line
 - PL Property Line
 - CL Center Line
 - BL Base Line
 - ML Main Line
 - EB Eastbound
 - WB Westbound
 - BM Bench Mark
 - STY Story
 - FRM Frame
 - SH Shed
 - GRG Garage
 - BRK Brick
 - SH Stone Highway
 - WSE&G New York State Elect. & Gas
 - TEL Telephone

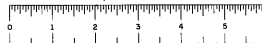
- GENERAL NOTES**
- THE GRID CONTROL SHOWN ON THE PLANS IS BASED ON NEW YORK STATE PLANE COORDINATES - CENTRAL ZONE. THE ELEVATION DATUM IS BASED ON U.S. COAST AND GEODETIC SURVEY BENCH MARK ELEVATIONS REFERRED TO MEAN SEA LEVEL.
 - THE CONTRACTOR'S ATTENTION IS DIRECTED TO THE SPECIAL NOTES FOR THE STRUCTURES WHICH APPEAR IN THE PROPOSAL. PARTICULAR ATTENTION SHOULD BE GIVEN TO THE FOUNDATION NOTES WHICH BRIEFLY OUTLINE THE INDICATED SUBSURFACE CONDITIONS AT THE SITE OF THE STRUCTURES AND WHICH SPECIFY CERTAIN REQUIREMENTS RELATIVE TO CONSTRUCTION.
 - IT SHALL BE THE RESPONSIBILITY OF THE CONTRACTOR TO ACQUAINT HIMSELF WITH THE DRAINAGE CHARACTERISTICS OF THE AREA, SO THAT HE WILL PROCEED HIS WORK WITH FULL KNOWLEDGE OF THE POTENTIAL DRAINAGE PROBLEMS.
 - ALL EXISTING DRAINAGE WITHIN THE LIMITS OF THE CONTRACT SHALL BE ABANDONED EXCEPT AS SHOWN ON THE PLANS, OR AS DIRECTED BY THE ENGINEER.
 - ALL EXISTING DRAINAGE LINES SHALL BE MAINTAINED IN SERVICE UNTIL THE REPLACEMENT LINES ARE COMPLETED.
 - THE COST OF PROVIDING ALL LABOR AND MATERIALS NECESSARY TO MAINTAIN SUFFICIENT FLOW OF CULVERT FLOW DURING CONSTRUCTION AS WELL AS THE COST OF KEEPING THE WORK FREE OF MUD, SNOW, AND ICE SHALL BE INCLUDED IN THE UNIT PRICE BID FOR ITEM 51 TRENCH AND CULVERT EXCAVATION.
 - THE LOCATION OF GAS AND WATER MAINS AND TELEPHONE DUCTS SHOWN ON THE PLANS OR AS DIRECTED BY THE ENGINEER IN ACCORDANCE WITH THE N.Y.S.D.P.M. POLICY AND STANDARDS MANUAL, FOR ENGINEERS TO STATE HIGHWAYS WHICH BECAME EFFECTIVE JULY 1, 1957.
 - TRAFFIC SIGNS FOR RESTRICTED HIGHWAYS SHALL BE LOCATED IN ACCORDANCE WITH THE STANDARD STRUCTURE SHEETS AND AS DIRECTED BY THE ENGINEER.
 - DRIVEWAYS SHALL BE REPAIRED AND RESURFACED AS SHOWN ON THE PLANS OR AS DIRECTED BY THE ENGINEER IN ACCORDANCE WITH THE N.Y.S.D.P.M. POLICY AND STANDARDS MANUAL, FOR ENGINEERS TO STATE HIGHWAYS WHICH BECAME EFFECTIVE JULY 1, 1957.

**TYPICAL SECTION STA. LIMITS,
MEDIAN WIDTHS,
LEGEND,
ABBREVIATIONS,
& GENERAL NOTES**

Prepared and recommended
A. O. G. O'DEA
CONSULTING ENGINEERS

Date: 11/19
Consulting Engineers

DRG. NO.	SCALE	DATE	GOODKIND & O'DEA CONSULTING ENGINEERS
T-0	None	11/19	

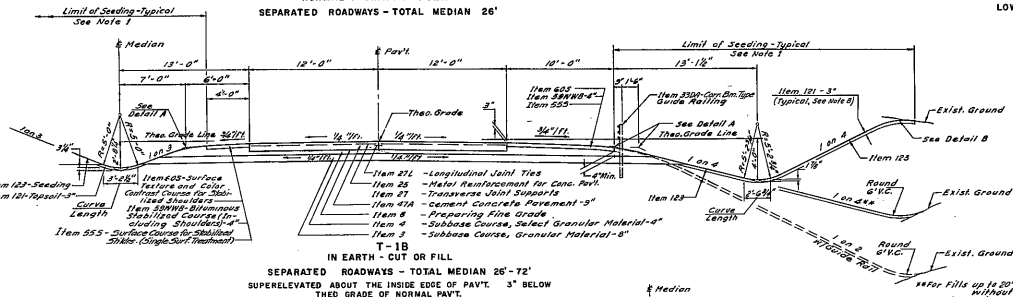


F.A.S.T. 67-4

FED. ROAD DIST. NO.	STATE	FED. AID PROJ. NO.	FISCAL YEAR	SHEET NO.	TOTAL SHEETS
1	N.Y.	APD 221-2(1)	3	200	

SOUTHERN TIER EXPRESSWAY SECTION 6R
LOWMAN - WAVERLY PART 1
CHEMUNG COUNTY

T-1A
HALF SECTION IN EARTH - CUT OR FILL
NORMAL PAVEMENT CROWN
SEPARATED ROADWAYS - TOTAL MEDIAN 26'



T-1B
IN EARTH - CUT OR FILL
SEPARATED ROADWAYS - TOTAL MEDIAN 26'-72"
SUPERELEVATED ABOVE THE INSIDE EDGE OF PAVT. 3" BELOW THEO GRADE OF NORMAL PAVT.

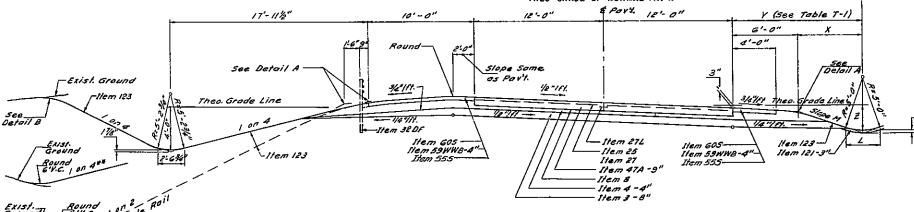
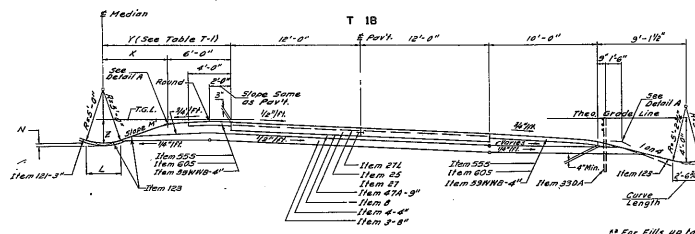


TABLE T-1

V	13'-0"	12'-0"	11'-0"	10'-0"	9'-0"	8'-0"	7'-0"	6'-0"
X	7'-0"	8'-0"	9'-0"	10'-0"	11'-0"	12'-0"	13'-0"	14'-0"
Y	100.3	100.55	100.8	101.05	101.3	101.55	101.8	102.05
Z	39'	38'	37'	36'	35'	34'	33'	32'
E	32.5'	32.5'	32.5'	32.5'	32.5'	32.5'	32.5'	32.5'
F	32.5'	32.5'	32.5'	32.5'	32.5'	32.5'	32.5'	32.5'

- NOTES:
- All earth graded areas and disturbed earth areas shall be fertilized and seeded.
 - Grass seedlings in the clear section shall be stock-piled and placed as directed by the Engineer or as shown on the plans.
 - The shoulder base slope above the same elevation of the pavement subbase material shall be fertilized and seeded only.
 - The height of fill is measured from the pavement edge to the top of slope.
 - In embankment sections, guide rolling shall be used on fill slopes greater than 1 on 4 or as shown on plans or as ordered by the Engineer.
 - Slope breaks at shoulders shall be rounded as shown on Detail A, Dwg. No. T-8.
 - Top of slope shall be rounded as shown on Detail B, Dwg. No. T-8.
 - Any excavation below the maximum pavement line shall be backfilled at the contractor's expense with approved materials as ordered and directed by the Engineer.

(LEFT HALF SECTION - READ OPPOSITE FROM TRAVEL DIRECTION)



(RIGHT HALF SECTION - READ IN TRAVEL DIRECTION)

In shops by A.S.P.
Made by A.S.P.
Checked by J.H.
Tried by J.H.
Checked by J.H.

Prepared and recommended by G. J. GARDNER & CO. Inc. Consulting Engineers

TYPICAL SECTIONS
MAINLINE
SEPARATED ROADWAYS

SHEET NO.	SCALE	DATE	ENGINEER
T-1	1/4" = 1'-0"	4/11/49	GOODRIND & ODEA CONSULTING ENGINEERS

NOTE: For Station Limits See Dwg. No. T-0

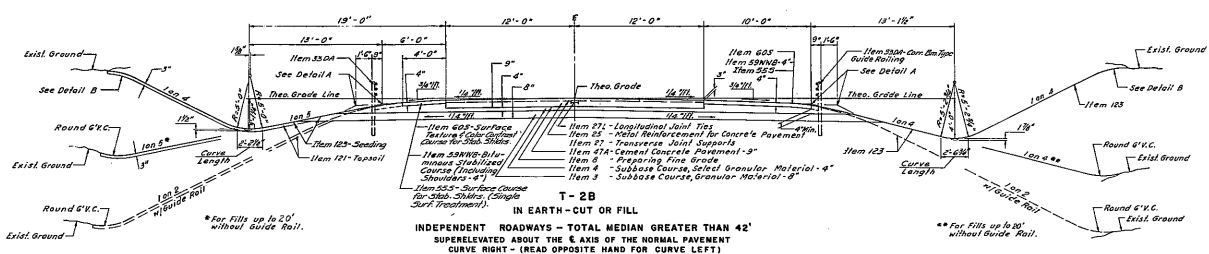


F.A.C.C.F. 67-4

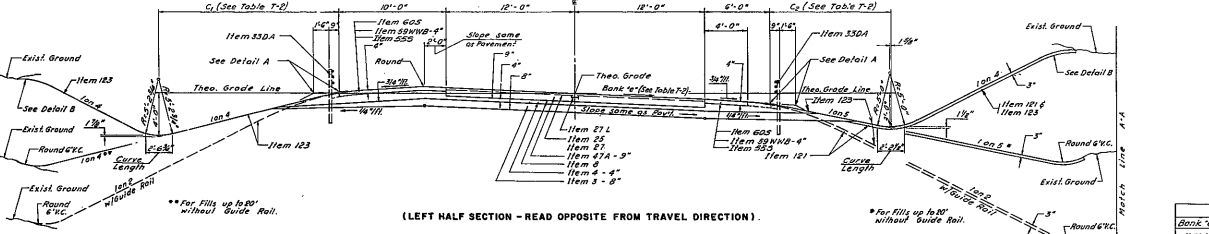
FED. ROAD REG. NO.	STATE	FED. AID PROJ. NO.	FISCAL YEAR	SHEET NO.	TOTAL SHEETS
1	N.Y.	APD 221(21)		4	200

T-2A
 HALF SECTION IN EARTH-CUT OR FILL
 NORMAL PAVEMENT CROWN
 INDEPENDENT ROADWAYS - TOTAL MEDIAN GREATER THAN 36'

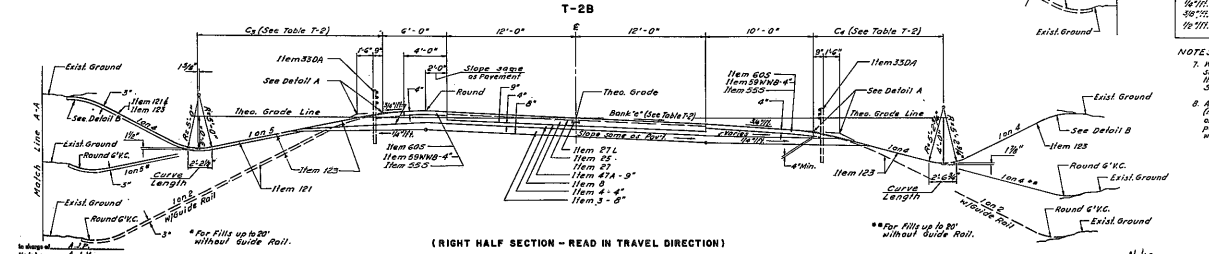
SOUTHERN TIER EXPRESSWAY SECTION 6R
 LOWMAN - WAVERLY PART 1
 CHEMUNG COUNTY



T-2B
 IN EARTH-CUT OR FILL
 INDEPENDENT ROADWAYS - TOTAL MEDIAN GREATER THAN 42'
 SUPERELEVATED ABOUT THE & AXIS OF THE NORMAL PAVEMENT
 CURVE RIGHT - (READ OPPOSITE HAND FOR CURVE LEFT)



(LEFT HALF SECTION - READ OPPOSITE FROM TRAVEL DIRECTION)



(RIGHT HALF SECTION - READ IN TRAVEL DIRECTION)

TABLE T-2

Bank %	C ₁	C ₂	C ₃	C ₄
30%	15'-0"	10'-0"	15'-0"	15'-10"
35%	16'-0"	11'-0"	16'-0"	16'-10"
40%	16'-10"	11'-3"	17'-3"	17'-10"

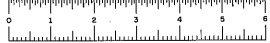
NOTES: (Continued)
 3. When guide rail is used the stabilized shoulder shall be extended 6 inches to the face of the guide rail post. See Detail A, Divg. No. T-8.
 4. All eastbound & westbound roadway side slopes (median & outside) shall be deposited, the depth of 3 inches, from the lower elevation of the pavement subbase material to the intersection with original ground.
 NOTE: For Station Limits See Divg. No. T-2

TYPICAL SECTIONS
 MAINLINE
 INDEPENDENT ROADWAYS

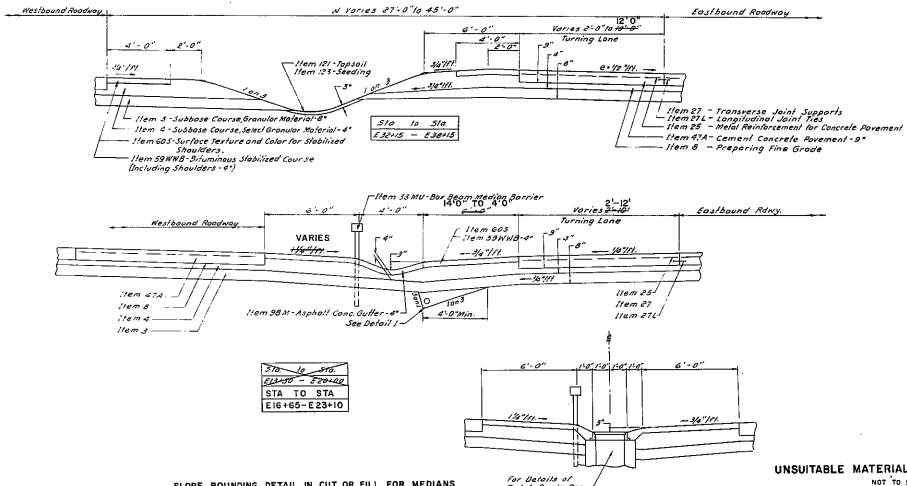
DWG. NO.	SCALE	DATE	GOODING & O'NEA CONSULTING ENGINEERS
T-2	1/4"=1'-0"	4/1/69	

In design by: J.P.S.
 Checked by: J.P.S.
 Drawn by: J.P.S.
 Checked by: J.P.S.

Prepared and recommended by: J.P.S. & O'NEA
 Checked by: J.P.S.
 Date: 4/1/69
 Consulting Engineers

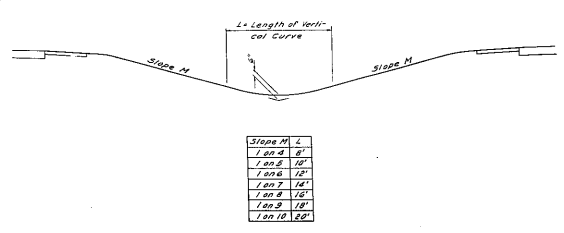


DETAIL OF MEDIAN LESS THAN 72 FT. WITH TURNING LANE
SCALE: 3/8" = 1'-0"

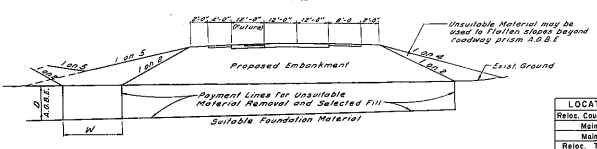


STA TO STA	E 2315 - E 2321 B
STA TO STA	E 1615 - E 2310

SLOPE ROUNDING DETAIL IN CUT OR FILL FOR MEDIANS GREATER THAN 72 FT. WITH INTERSECTING SLOPES
SCALE: 1/4" = 1'-0"

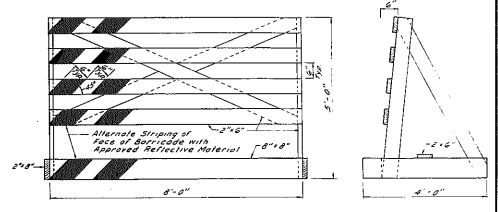


UNDESIRABLE MATERIAL REMOVAL SECTION
NOT TO SCALE



- NOTES:
- The transverse payment lines for removal shall be toe to toe of the 1 on 2 slope as shown.
 - Backfill with Item 202-EX, Selected Fill, to an elevation 2 feet above water surface at the time of construction or as ordered by Engineer.
 - Unsuitable material shall be removed from the median when the distance (W) between excavation limits (described in note 1) is less than depth of unsuitable material (D).
 - Unsuitable material shall be excavated under Item 2, Unclassified Excavation, to depths ordered by Engineer. (D)
 - Where unsuitable materials exist past the ends of any culvert, it should be removed beyond the toe of slope for a distance of 10 feet on each side of the culvert and for 10 feet past the face of the headwalls.

WOOD HIGHWAY BARRICADE, ITEM 213
SCALE: 3/4" = 1'-0"



LOCATIONS	LENGTH (L.F.)
N. Sta. W 118+20.0	40
N. Sta. E 178+00.0 to E 183+00.0	400
Ramp E 10+33.5	112
Ramp E 28+05.2	112
Beginning of Project for Maintenance of Traffic	240
LOCATIONS	LENGTH (L.F.)
N. Sta. W 118+00.0	35
N. Sta. E 172+00.0 to 183+00.0	1040
Ramp E 10+33.5	48
Ramp E 28+05.2	91
Beginning of Project for Maintenance of Traffic	332

- NOTES:
- ALL LUMBER SHALL BE DOUGLAS FIR, COMMON GR. UNLESS OTHERWISE SPECIFIED. BARRICADES SHALL BE CONST. IN SECTIONS AS SHOWN.
 - UPON COMPLETION, ALL LUMBER SHALL BE PAINTED WITH TWO (2) COATS OF WHITE PRIMER, AFTER WHICH THE REFLECTIVE MATERIAL SHALL BE APPLIED AS SHOWN.

LOCATIONS	STA. TO STA.
Ridge County Reg 9	A42+102 - A43+102
Mainline	W219+502 - W221+002
Mainline	E 231+002 - E 232+002
Ridge T.R. 283	G37+002 - G42+002

REVISIONS

- TURNING LANE
- BARRICADE

TYPICAL SECTIONS
MISCELLANEOUS DETAILS

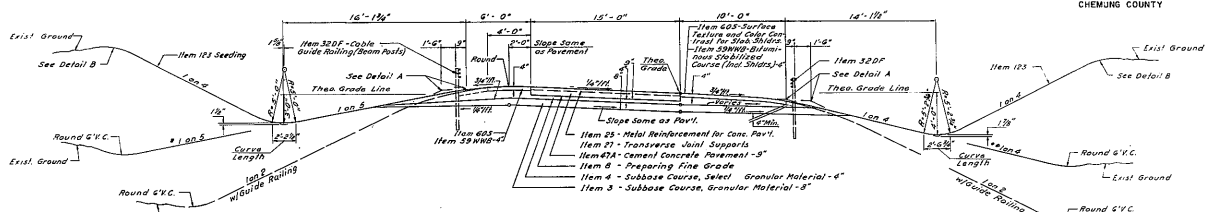
Prepared and recommended
M. O. A. GOODING & ODEA
Consulting Engineers

Date: 4/1/77
Consulting Engineers

DWG. NO.	SCALE	DATE	GOODING & ODEA CONSULTING ENGINEERS
T - 3	As Shown	4/1/77	

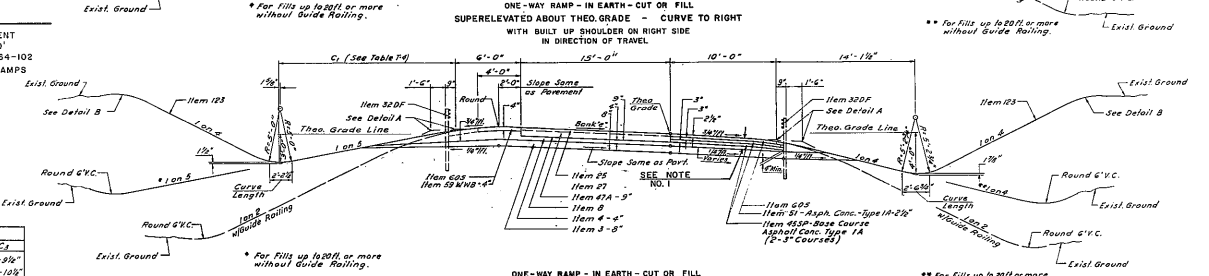
ONE-WAY RAMP - IN EARTH - CUT OR FILL
NORMAL PAVEMENT CROSS SLOPE - IN DIRECTION OF TRAVEL

SOUTHERN TIER EXPRESSWAY SECTION GR
LOWMAN - WAVERLY PART 1
CHEMUNG COUNTY

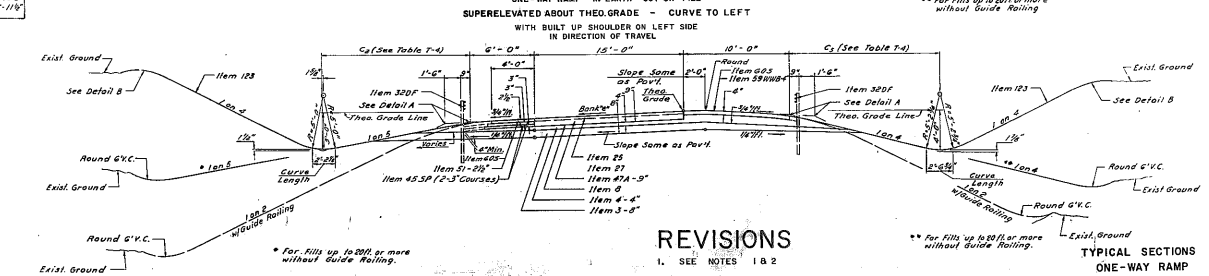


NOTES

- FULL SHOULDER TREATMENT 20' BEFORE P.C. TO 10' BEYOND P.T. LETTER 64-102
- ADDED TOPSOIL ON RAMP



Bank %	C ₁	C ₂	C ₃
16 1/2%	10'-10"	12'-2 1/2"	14'-9 1/2"
18 1/2%	11'-4 1/2"	13'-0"	15'-0"
20%	11'-11"	13'-7 1/2"	15'-11"



REVISIONS

- SEE NOTES 1 & 2

In charge of A. J. P.
 Drafted by A. J. P.
 Checked by N. B.
 Revised by A. J. P.
 Checked by A. J. P.

Printed and recommended
 W-214-102-80
 GOODKIND & DYBA
 Consulting Engineers

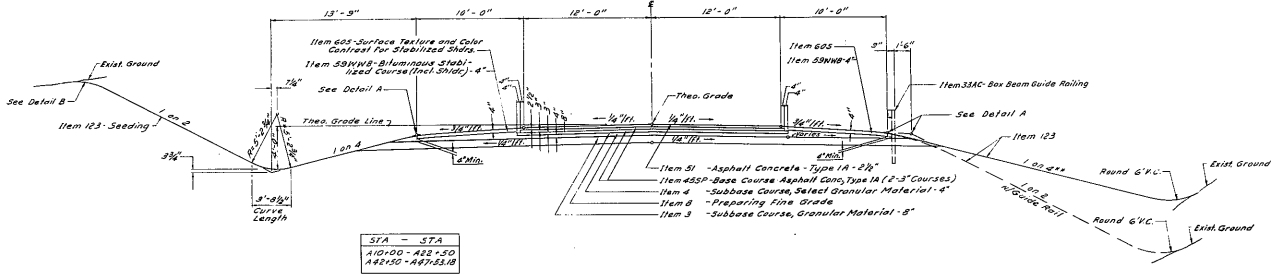
Date: 4/17
 DWG. NO. T-4
 SCALE 1/4"=1'-0"
 DATE 4/17
 GOODKIND & DYBA
 CONSULTING ENGINEERS

TYPICAL SECTIONS
ONE-WAY RAMP

FED. ROAD DIST. NO.	STATE	FED. AID PROJ. NO.	FISCAL YEAR	SHEET NO.	TOTAL SHEETS
1	N.Y.			T-1	19 D

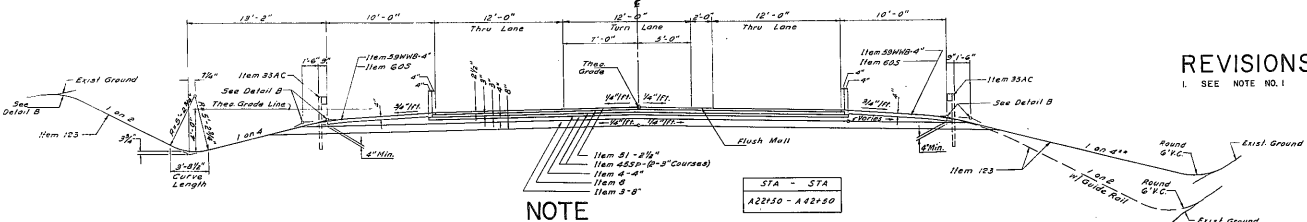
SOUTHERN TIER EXPRESSWAY SECTION GR
LOWMAN - WAYERLY PART I
CHEMUNG COUNTY

**RELOCATED COUNTY ROAD 9
IN EARTH - CUT OR FILL
NORMAL PAVEMENT CROWN**



** For fills up 20' or more without Guide Rail.

**RELOCATED COUNTY ROAD 9
IN EARTH - CUT OR FILL
NORMAL PAVEMENT CROWN**



REVISIONS
I. SEE NOTE NO. 1

NOTE
I. ADDED TOPSOIL ON COUNTY ROAD 9

** For fills up to 20' or more without Guide Rail.

**TYPICAL SECTIONS
RELOCATED COUNTY ROAD 9**

Prepared and recommended by: [Signature]
GOODKIND & O'DEA
Consulting Engineers

DWG. NO.	SCALE	DATE	GOODKIND & O'DEA - CONSULTING ENGINEERS
T-5	1/4"=1'-0"	4/1/17	

Checked by: [Signature]
 Made by: [Signature]
 Created by: [Signature]

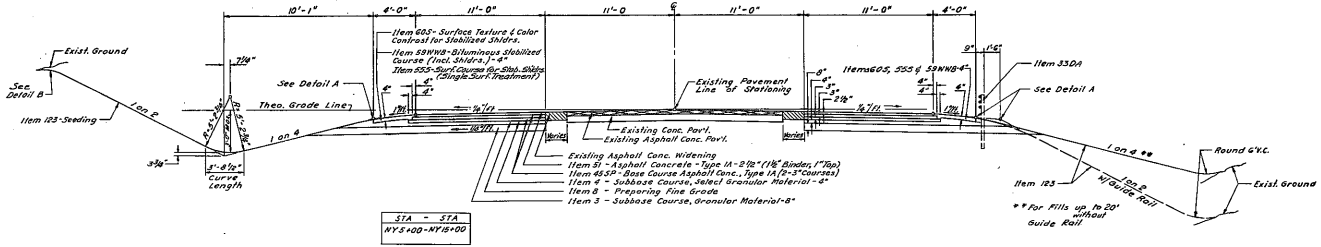


F.A.C.T.R. 67-4

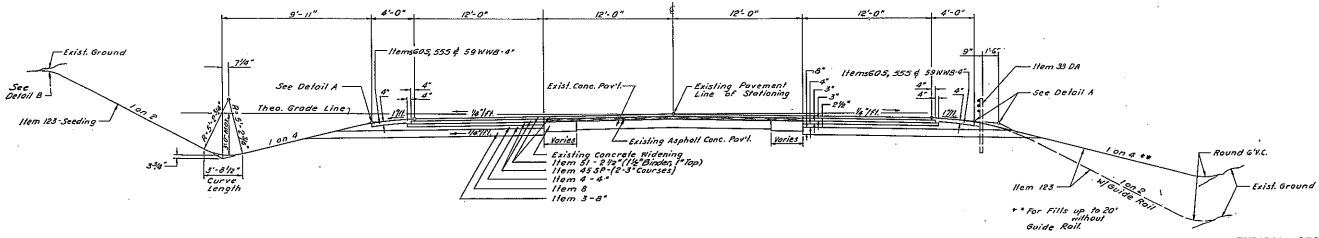
FED. ROAD DIST. NO.	STATE	FED. AID PROJ. NO.	FISCAL YEAR	SHEET NO.	TOTAL SHEETS
1	N.Y.	APD 221-0211	67	200	200

SOUTHERN TIER EXPRESSWAY SECTION ER - LOWMAN - WAVERLY PART I
CHEMUNG COUNTY

RECONSTRUCTED ROUTE 427
NORMAL PAVEMENT CROWN



RECONSTRUCTED ROUTE 17
NORMAL PAVEMENT CROWN



TYPICAL SECTIONS

SAFETY WIDENING
RECONSTRUCTED ROUTE 17
RECONSTRUCTED ROUTE 427

Prepared and recommended
11-9-11
COOPER & O'BEA
Consulting Engineers

Date: 4/1/17

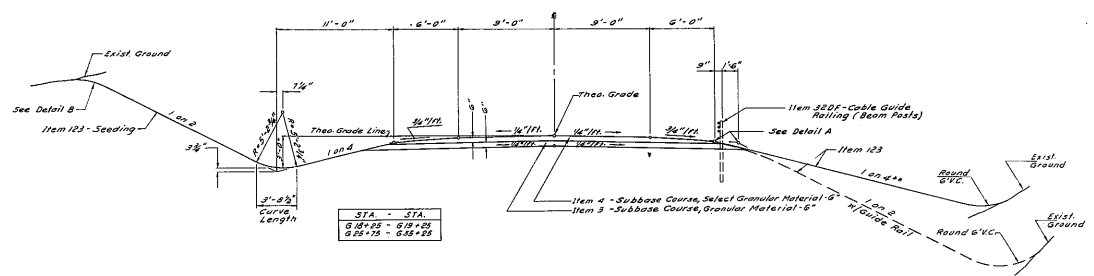
CONG. NO. SCALE DATE
T-BA 1/4"=1'-0" 4/1/17
COOPER & O'BEA
CONSULTING ENGINEERS

Checked by: J.P.P.
Drawn by: J.P.P.
Scale: 1/4"=1'-0"

FED. ROAD DIST. NO.	STATE	FED. AID PROJ. NO.	FISCAL YEAR	SHEET NO.	TOTAL SHEETS
1	N.Y.			9 R1	199

IN EARTH - CUT OR FILL
NORMAL PAVEMENT CROWN
RELOCATED T.R. 283

SOUTHERN TIER EXPRESSWAY SECTION 6R
LOWMAN - WAVERLY PART 1
CHEMUNG COUNTY



IN EARTH - CUT OR FILL
SUPERELEVATED ABOUT CENTER LINE AXIS
OF THE NORMAL PAVEMENT, CURVE RIGHT
(READ OPPOSITE HAND FOR CURVE LEFT)
RELOCATED T.R. 283

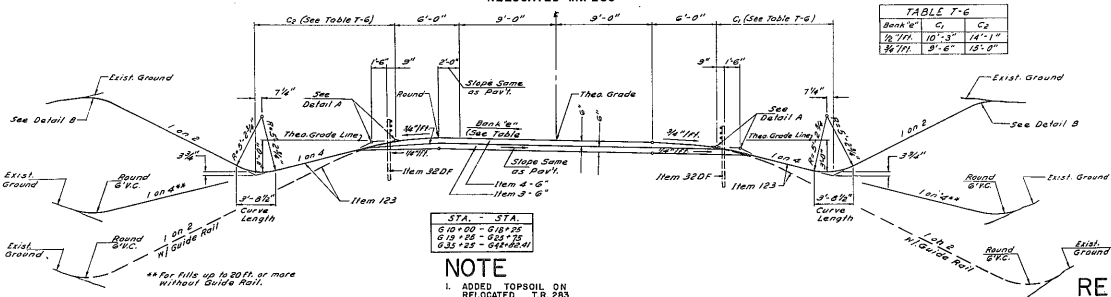


TABLE T-6

Bank	C ₁	C ₂
7 1/2%	10'-3"	14'-1"
3 3/4%	9'-6"	13'-0"

NOTE
1. ADDED TOPSOIL ON
RELOCATED T.R. 283

REVISIONS
1. SEE NOTE NO. 1

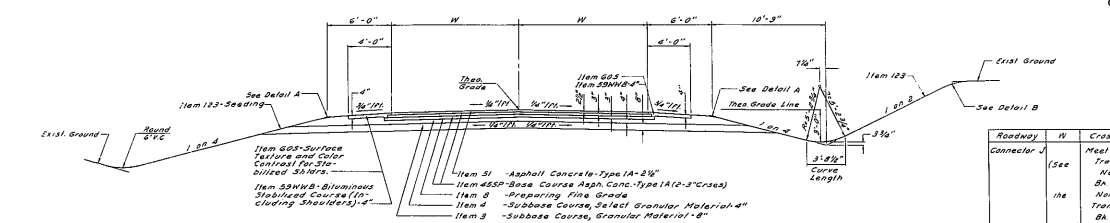
In charge of A.J.D.
 Made by G.D.E.
 Checked by G.D.E.
 Tracked by G.D.E.
 Checked by G.D.E.

Prepared and recommended
M. O. H. V. P. O. R.
 GOODING & ODEA
 Consulting Engineers

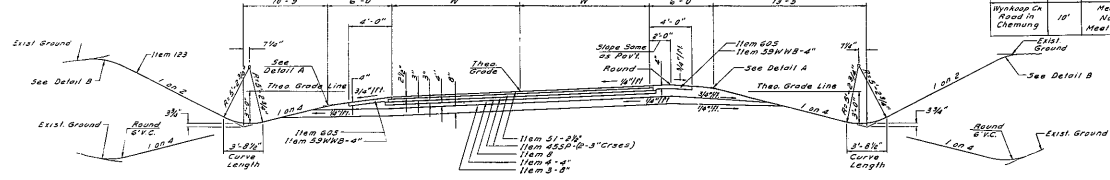
TYPICAL SECTIONS
 RELOCATED TOWN ROAD 283
 DWG. NO. T-6 SCALE 1/4"=1'-0" DATE 4/1/67
 GOODING & ODEA - CONSULTING ENGINEERS

FED. ROAD REG. NO.	STATE	FED. AID PROJ. NO.	FISCAL YEAR	SHEET NO.	TOTAL SHEETS
1	N.Y.			101	199

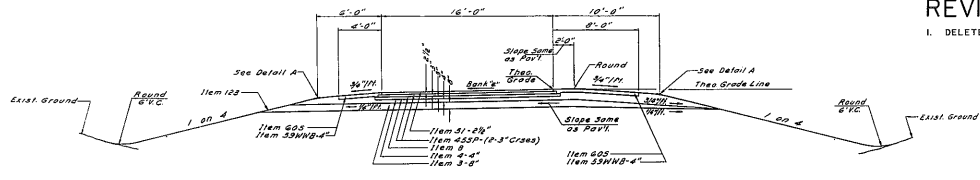
IN EARTH - CUT OR FILL
NORMAL PAVEMENT CROWN
T-7A



IN EARTH - CUT OR FILL
SUPERELEVATED ABOUT CENTER LINE AXIS
OF THE NORMAL PAVEMENT CURVE LEFT
(READ OPPOSITE HAND FOR CURVE RIGHT)
T-7B



IN EARTH - FILL
NORMAL AND SUPERELEVATED ABOUT
THEO. GRADE CURVE LEFT
CONNECTOR K



Connector K	Sta to Sta	Bank %	
	617877	87736	Varies

Roadway	W	Cross Slope	Sta to Sta	Secl.
Connector J	Meet Mainline	J1+12	J1+12	T-7B
	Transition	J1+12 - J8+00	J1+12	T-7B
	Normal	J8+00	J1+12	T-7A
	Sh. Lt. 1/4	J8+00 - J8+73.92	J1+12	T-7B
Plane	Normal	J8+73.92 - J8+00	J1+12	T-7A
	Transition	J8+00 - J10+15	J1+12	T-7B
	Sh. Rt. 1/4	J10+15 - J11+15	J1+12	T-7B
	Transition	J11+15 - J12+50	J1+12	T-7B
Connector L	Meet East Part	J12+50	J12+50	T-7B
	Meet Mainline	L10+12	L10+12 - L12+04	T-7A
Wynkoop Cr. Road in Chemung	Meet East Part	L12+04	L12+04	T-7A
	Normal	M10+18 - M12+00	M10+18	T-7A

REVISIONS

I. DELETE CONNECTORS J, K & L ONLY

TYPICAL SECTIONS
CONNECTORS J, K & L
RECONSTR. WYMKOP CREEK ROAD

Prepared and recommended
11-0-11-11-02
GODDARD & O'NEA
Consulting Engineers

SHEET NO.	SCALE	DATE	GODDARD & O'NEA CONSULTING ENGINEERS
T-7	1/4"=1'-0"	11/11	

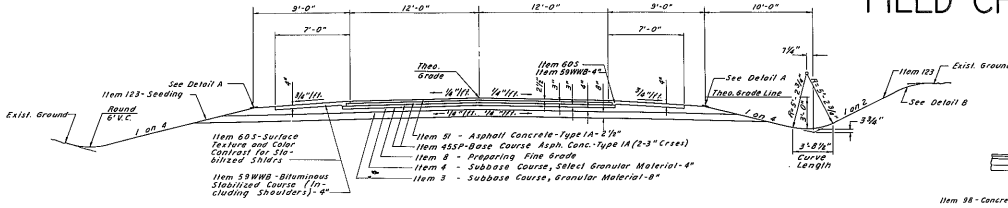
In Charge of
 Checked by
 Drawn by
 Date

FED. ROAD REG. NO.	STATE	FED. AID PROJ. NO.	FISCAL YEAR	SHEET NO.	TOTAL SHEETS
1	N.Y.			10 F1	

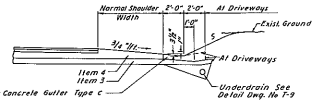
SOUTHERN TIER EXPRESSWAY SECTION 6R
LOWMAN - WAVERLY PART 1
CHEMUNG COUNTY

FIELD CHANGE

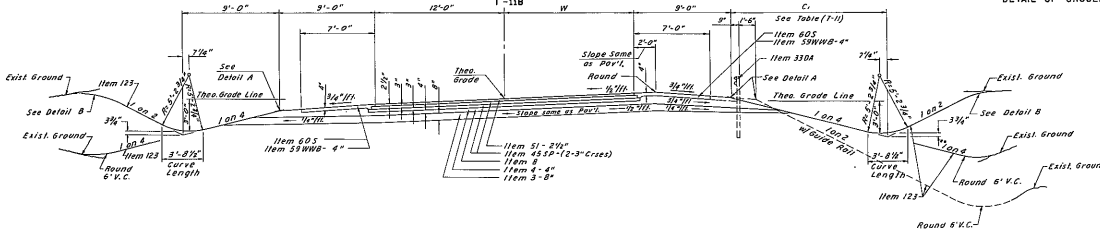
IN EARTH - CUT OR FILL
NORMAL PAVEMENT CROWN
T-11A



NAME	STA	TO STA	SCALE
Relocated Route 17	10175	11725	1" = 40'
Relocated Route 17	11725	11800	1" = 40'



IN EARTH - CUT OR FILL
SUPERELEVATED ABOUT CENTER LINE AXIS
OF THE NORMAL PAVEMENT CURVE LEFT
(READ OPPOSITE HAND FOR CURVE RIGHT)
T-11B



Roadway	W	Cross Slope	Sta	To Sta	Scale
Relocated Route 17	(See Plans)	Meet Exist. Pav't	10100	10100	7'-10"
		Transition	11175	11175	
		Bank Left 1/2"	11175	14125	
		Transition	14125	18175	
		Bank Right 1/2"	18175	21150	
		Transition	21150	24150	
		Bank Left 1/2"	24150	29425	
Connector V	12'	Meet Exist. Pav't	30175	30175	7'-10"
		Meet Mainline	V10112	V10112	
		Meet Mainline	V10112	V12420	

Bank "	W	C
1/2"	12'	13'-10"
3/4"	24'	15'-10"

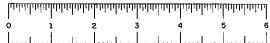
** For fills up to 10 ft. or more without Guide Rail

THIS SHEET DELETES THE SECTIONS FOR CONNECTOR'S "J", "K" AND "L" AND PROVIDES THE NEW TYPICAL SECTIONS FOR RELOCATED ROUTE 17 AND THE "V" CONNECTOR.

APPROVED
Date: 2-16-67
[Signature]
Asst. State Chief Engineer

Prepared and recommended by: [Signature]
GOODKIND & ODEA
Consulting Engineers

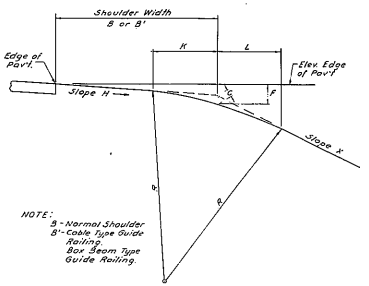
TYPICAL SECTIONS
RELOCATED ROUTE 17
CONNECTOR V
DWG. NO. SCALE DATE
GOODKIND & ODEA CONSULTING ENGINEERS



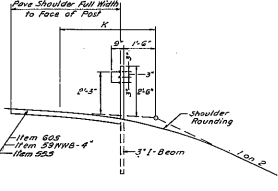
FED. ROAD DIST. NO.	STATE	FED. AID PROJ. NO.	FISCAL YEAR	SHEET NO.	TOTAL SHEETS
1	N.Y.	APD 221(421)		11	200

SOUTHERN TIER EXPRESSWAY SECTION 6R
LOWMAN - WATERY PART 1
CHEMUNG COUNTY

**DETAIL A
NORMAL SHOULDER ROUNDING**
NOT TO SCALE

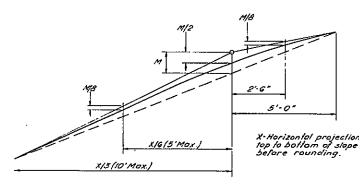


NOTE:
B - Normal Shoulder
B' - Chain Type Guide Rolling
B'' - Beam Type Guide Rolling

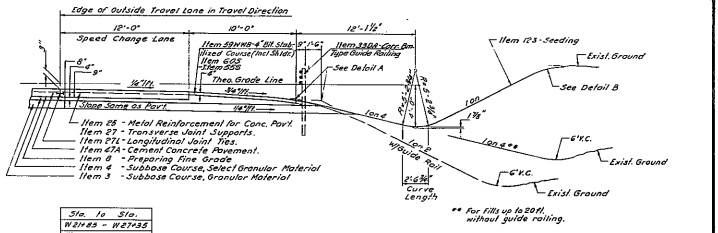


GUIDE RAIL & SHOULDER PAVING DETAIL

**DETAIL B
ROUNDING TOP OF CUT SLOPE**
NOT TO SCALE



SPEED CHANGE LANE - IN EARTH - CUT OR FILL
NORMAL PAVEMENT CROSS SECTION
SCALE: 1/4" = 1'-0"



5/16" to 5/8"
W24x85 - W27x85
W36x85 - W40x10
W12x75 - W12x50

SPEED CHANGE LANE - IN EARTH - CUT OR FILL
HIGH SIDE OF SUPERELEVATED PAVEMENT
SCALE: 1/4" = 1'-0"

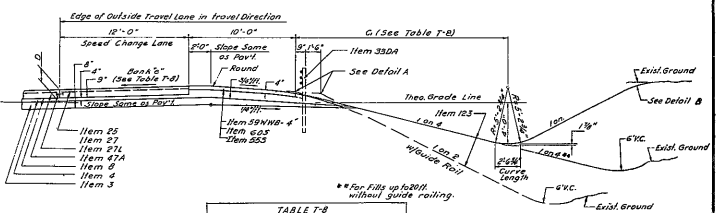


TABLE T-8
Slopes to Slopes
Slopes to Slopes
Slopes to Slopes

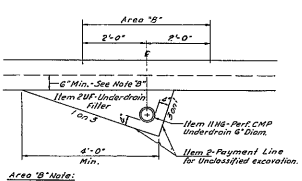
TYPICAL SECTIONS
DETAILS

Slope X+1 on 3	Slope X+1 on 4			Slope X+1 on 5		
	H per ft. 3/4"	H per ft. 1"	H per ft. 1 1/4"	H per ft. 1 1/2"	H per ft. 1 3/4"	H per ft. 2"
3/4"	0.44'	0.40'	0.35'	0.30'	0.25'	0.20'
1"	0.57'	0.48'	0.38'	0.33'	0.28'	0.23'
1 1/4"	0.69'	0.55'	0.42'	0.36'	0.31'	0.26'
1 1/2"	0.81'	0.64'	0.48'	0.41'	0.35'	0.29'
2"	1.14'	0.88'	0.63'	0.54'	0.46'	0.38'
3"	1.71'	1.26'	0.90'	0.78'	0.66'	0.54'
4"	2.28'	1.68'	1.17'	1.02'	0.87'	0.72'
5"	2.85'	2.10'	1.47'	1.28'	1.10'	0.92'

Slope in per ft.	Radius R	Curve Ton.	Curve Ext.	K	L	C
3/4"	102'	21.76'	4.43'	0.44'	4.42'	3.96'
1"	102'	23.61'	4.80'	0.48'	4.79'	4.29'
1 1/4"	102'	26.90'	5.09'	0.51'	5.08'	4.59'
1 1/2"	102'	29.53'	5.33'	0.54'	5.32'	4.84'
2"	102'	40.96'	7.01'	0.70'	6.99'	6.40'
3"	102'	64.76'	10.07'	1.00'	9.99'	9.06'
4"	102'	103.37'	15.00'	1.50'	14.99'	13.13'

NOTE: Where other rates of 5' Slopes are necessary, the value of 'C' may be obtained by interpolating in the table.

**DETAIL I
UNDERDRAIN TRENCH CUT SECTION**
NOT TO SCALE



Area 'B' Note:
After placing Pipe and Backfill the wheels or tracks of any equipment shall not operate in this area until the Pavt. Subbase has been placed to a minimum depth of 6 inches.

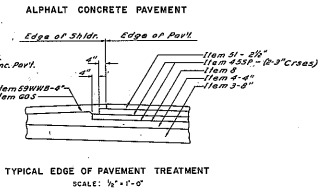
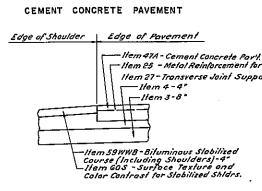
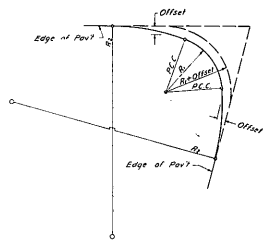
In charge of: A. J. P.
Made by: M. D.
Checked by: M. D.
Traced by: M. D.
Checked by: A. J. P.

Prepared and recommended
GODDARD & O'DEA
Consulting Engineers

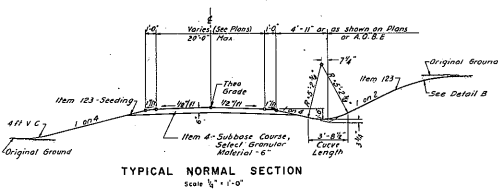
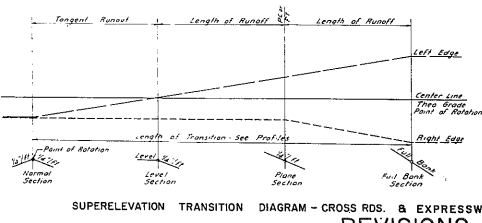
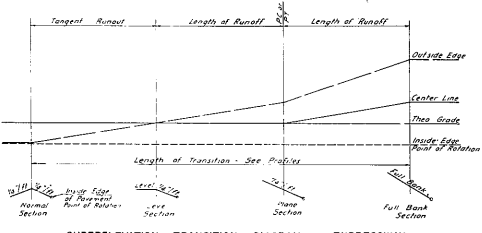
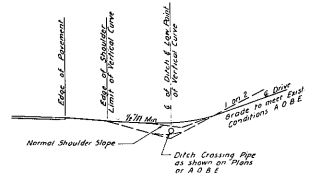
DWG. NO.	SCALE	DATE	GOODRIND & O'DEA CONSULTING ENGINEERS
T-8	AS SHOWN	4/11/77	

FED. ROAD DIST. NO.	STATE	FED. AID PROJ. NO.	SHEET NO.	TOTAL SHEETS
1	N.Y.		12 OF 19	199

SOUTHERN TIER EXPRESSWAY SECTION 6R
LOWMAN - WAVERLY PART 1
CHEMUNG COUNTY



TYPICAL EDGE OF PAVEMENT TREATMENT
SCALE: 1/2" = 1'-0"

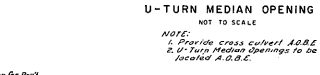
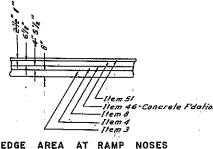
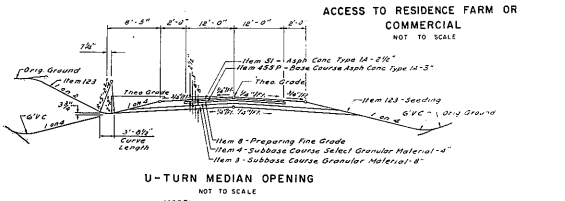


DRIVES

CONNECTOR	VOID
ROUTE 17	P11+20, RL
ROUTE 17	P11+80, LL
ROUTE 17	P12+55, LL
ROUTE 17	P13+55, RL

TURN-AROUNDS MAINLINE

VOID
W20+60-100' RL
E20+40-125' RL
W21+40-475' LL
W21+75-430' LL



TYPICAL SECTIONS
DRIVES, TURN-AROUNDS, MISCELLANEOUS DETAILS

In Charge of A.J.P.
 Made by A.V.V.
 Checked by S.S.
 Titled by R.C.E.F.W.
 Checked by L.V.P.

REVISIONS

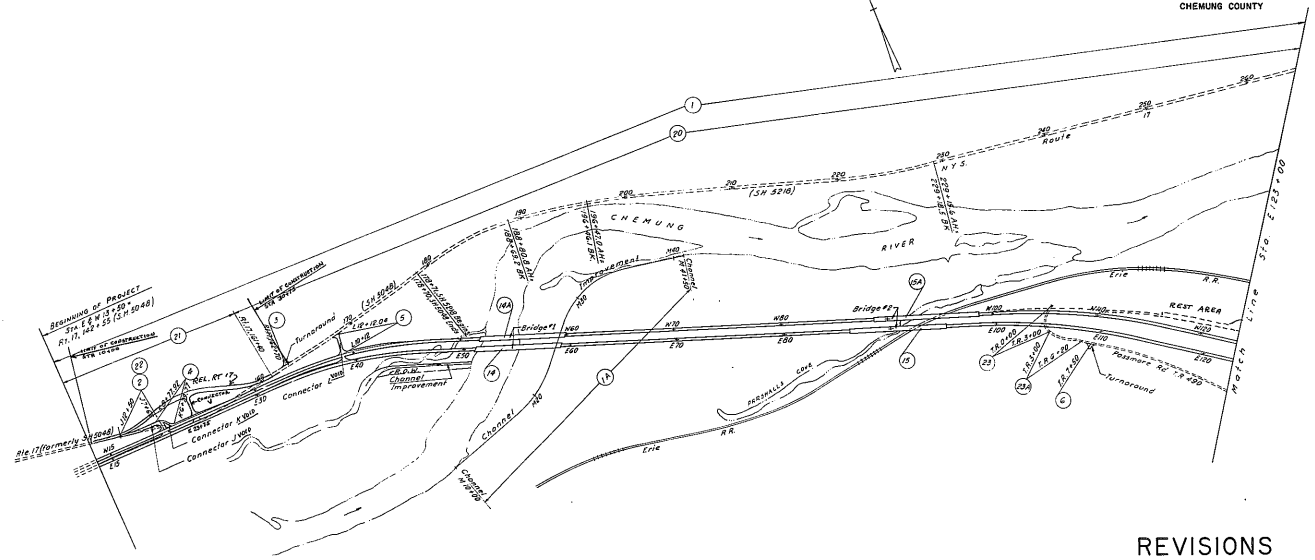
1. TYPICAL NORMAL SECTION (DRIVES)
2. TYPICAL NORMAL SECTION (TURN-AROUNDS MAINLINE)
3. WEDGE AREA AT RAMP NOSES

Prepared and Examined
[Signature]
 Consulting Engineers

DES. NO.	SCALE	DATE	GODDARD & O'DEA CONSULTING ENGINEERS
T-3	AS SHOWN	4/1/67	

FED. ROAD REG. NO.	STATE	FED. AID PROJ. NO.	FISCAL YEAR	SHEET NO.	TOTAL SHEETS
1	N.Y.			13 R/	199

SOUTHERN TIER EXPRESSWAY SECTION 6R
LOWMAN - WAVERLY PART 1
CHEMUNG COUNTY



- REVISIONS**
1. REST AREA (NEW)
 2. NEW DESIGN CONNECTOR V
 3. ALIGNMENT REVISION REL. RT. 17
 4. CONNECTOR J VOID
 5. CONNECTOR K VOID
 6. CONNECTOR L VOID

In Charge: *[Signature]*
 Checked By: *[Signature]*
 Date: *[Date]*

Prepared and recommended by: *[Signature]*
GOODKIND & O'DEA
 Consulting Engineers

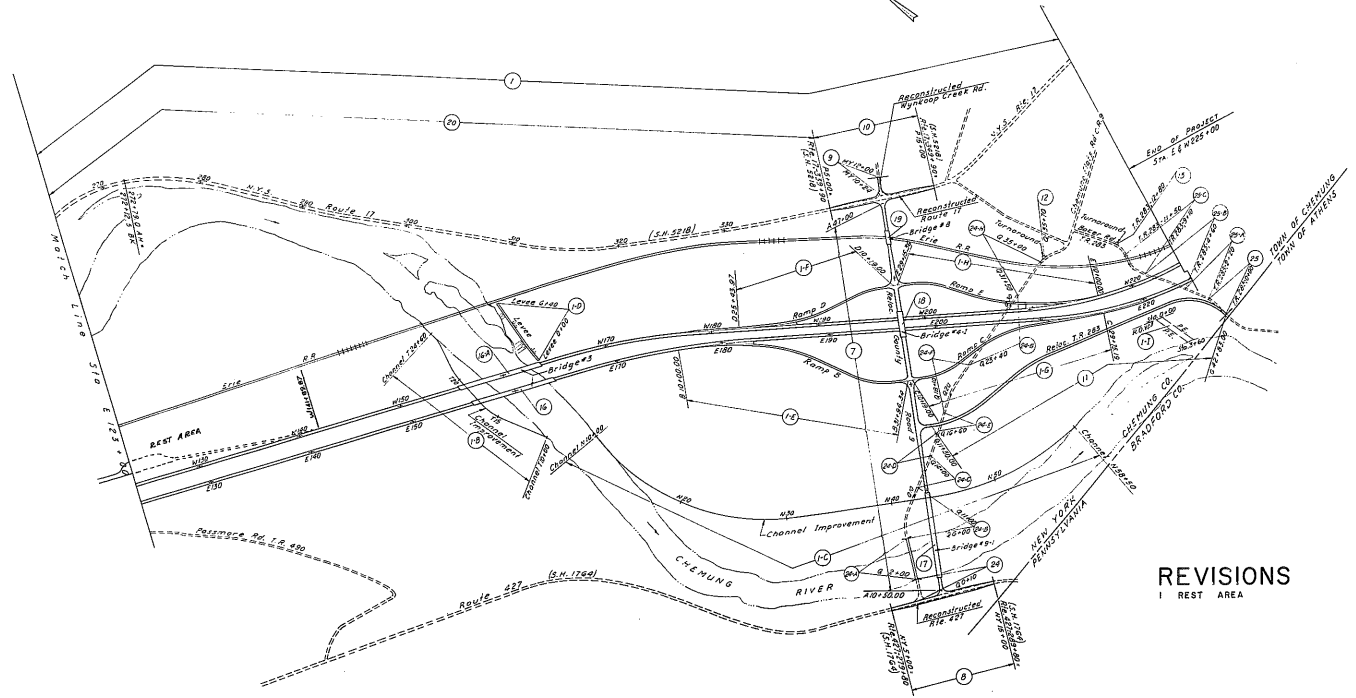
MAINTENANCE PLAN

DWG. NO.	SCALE	DATE	GOODKIND & O'DEA CONSULTING ENGINEERS
M-1	—	4/1/69	

FED. ROAD REG. NO.	STATE	FED. AID PROJ. NO.	FISCAL YEAR	SHEET NO.	TOTAL SHEETS
1	N.Y.			14 R1	199

SOUTHERN TIER EXPRESSWAY SECTION 6R

LOWMAN - WAVERLY PART 1
CHEMUNG COUNTY



Checked by: [Signature]
 Made by: [Signature]
 Drawn by: [Signature]

Prepared and recommended
 M. J. [Signature]
 GOODING & O'DEA
 Consulting Engineers

Date: 4/1/79

MAINTENANCE PLAN

DWG. NO.	SCALE	DATE	GOODING & O'DEA CONSULTING ENGINEERS
M-2	—	4/1/79	

TABLE OF MAINTENANCE

PART	HIGHWAY	LIMITS	FEATURES TO BE MAINTAINED	MILES	AGENCY	AUTHORITY FOR MAINTENANCE JURISDICTION
EXPRESSWAY AND RAMPS						
1	Southern Tier Expressway	E N 13130 to E N 22500	Mainline Roadway including Pav. Shoulders, Drainage System, Landscaping	4.01	State	Section 360-d Highway Law
1-A	Channel Improvement Chemung River	M 10100 to M 41150	Stream Channel and banks within ROW	0.29	State	" " " " " "
1-B	Channel Improvement Chemung River	T 10100 to T 24150	" " " " " "	0.28	State	" " " " " "
1-C	Channel Improvement Chemung River	N 10100 to N 38150	" " " " " "	0.28	State	" " " " " "
1-D	Levee Chemung River	0100 to 6100	Levee and banks within ROW	0.16	State	" " " " " "
1-E	Ramp B	E 10100 to E 31194.34	Pavement, Shoulders, Drainage System, Landscaping	0.41	State	" " " " " "
1-F	Ramp D	D 1011800 to D 25143.97	" " " " " "	0.29	State	" " " " " "
1-G	Ramp C	C 1011800 to C 29175.12	" " " " " "	0.37	State	" " " " " "
1-H	Ramp E	E 10100 to E 29115.36	" " " " " "	0.36	State	" " " " " "
1-I	Ditch	0100 to 3160	Ditch and slopes within ROW and PE taking lines	0.07	State	" " " " " "
CROSS ROADS, SERVICE ROADS AND INTERSECTIONS						
2	Connector F VOID	F 10100 to F 18150	Pavement, Shoulders, drainage system, Landscaping	0.09	County Chemung	Section 360-d Highway Law
3	Turnaround - Route 17 (SH 5040)	R 1117 162170 to 162170	" " " " " "	0.04	County Chemung	" " " " " "
4	Connector V	10112 to 12112	" " " " " "	0.04	County Chemung	" " " " " "
5	Connector K VOID	K 101227 to K 161227	" " " " " "	0.04	County Chemung	" " " " " "
6	Connector L VOID	L 101200 to L 121200	" " " " " "	0.06	County Chemung	" " " " " "
7	Turnaround - Passmore Road	T R 490 1150 to R 11	" " " " " "	0.70	Town Chemung	" " " " " "
8	County Road P	A 101500 to A 112100	" " " " " "	0.19	State	" " " " " "
9	Route 427 (SH 1762)	N Y 5100 to N Y 13100	" " " " " "	0.19	State	" " " " " "
10	Wynkoop Creek Road	M X 10158 to M Y 15100	" " " " " "	0.03	Town Chemung	" " " " " "
11	Route 17	P 5100 to P 15100	" " " " " "	0.17	County Chemung	" " " " " "
12	Town Road 283	G 11130 to G 25183	" " " " " "	0.60	Town Chemung	" " " " " "
13	Turnaround - Chemung Falls Road, City Rd. 9	G 35170 to G 41170	" " " " " "	-	County Chemung	" " " " " "
14	Turnaround - Baker Road, T.R. 283	T R 283 12100 to 12100	" " " " " "	-	Town Chemung	" " " " " "
STATE ROUTES						
14	Bridge over Chemung River	E 51101.03 to E 59112.839	Entire Structure	0.02	State	Section 360-d Highway Law
14-A	Bridge over Chemung River	N 51172.872 to N 59175.128	" " " " " "	0.02	State	" " " " " "
15	Bridge over Erie Railroad	E 06101.42 to E 95116.39	" " " " " "	0.17	State	" " " " " "
15-A	Bridge over Erie Railroad	N 01150.75 to N 79172.72	" " " " " "	0.21	State	" " " " " "
16	Bridge over Chemung River	E 155169.221 to E 163172.201	" " " " " "	0.15	State	" " " " " "
16-A	Bridge over Chemung River	N 155172.201 to N 163172.201	" " " " " "	0.15	State	" " " " " "
17	Bridge over Chemung River	A 11171.000 to A 17173.835	" " " " " "	0.15	State	" " " " " "
18	Bridge over Southern Tier Expressway	A 36154.701 to A 36173.670	" " " " " "	0.04	State	" " " " " "
19	Bridge over Erie Railroad	A 43102.19 to A 49160.56	" " " " " "	0.03	State	" " " " " "
ROADS ABANDONED						
20	Route 17 (Retained in Service)	R 1117 162170 to R 1117 162170	Abandoned to County of Chemung	0.34	County Chemung	Section 62 Highway Law
ROADS DESTROYED BY CONSTRUCTION						
21	Route 17 (SH 5040)	R 1117 162155 to R 1117 162170	Destroyed by construction	0.39	State	Section 360-d Highway Law
22	Route 17 (Formerly SH 5040)	J 7163 to J 12150	" " " " " "	0.08	Town Chemung	" " " " " "
23	Passmore Road T.R. 490	T R 490 - 0100 to T R 490 - 3100	" " " " " "	0.06	Town Chemung	" " " " " "
23-A	Passmore Road T.R. 490	T R 490 - 3100 to T R 490 - 6120	Abandon and remove	0.03	Town Chemung	" " " " " "

In charge of A.S.P.
Made by A.S.P.
Checked by A.S.P.
Checked by A.S.P.

REVISIONS
1 CROSS ROADS, SERVICE ROADS AND INTERSECTIONS

2 ROADS ABANDONED
3 ROADS DESTROYED BY CONSTRUCTION

Prepared and recommended by
A. J. O'NEILL
COUNTY ENGINEER

Date 4/1/67

DWG. NO.	SCALE	DATE	BOOKING & ODEA
M-3	-	4/1/67	CONSULTING ENGINEERS

SOUTHERN TIER EXPRESSWAY PART 1
LOWMAN - WAVERLY PART 1
CHEMUNG COUNTY

TABLE OF MAINTENANCE

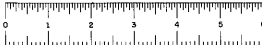
PARTIAL	HIGHWAY	LIMITS	FEATURES TO BE MAINTAINED	MILES	AGENCY	AUTHORITY FOR MAINTENANCE CONSTRUCTION	
						SECTION	SECTION
ROADS DESTROYED BY CONSTRUCTION (CONT'D)							
24	Chemung Flats County Road 9	Q 2110 to Q 2100	Abandon and Remove	0.04	County Chemung	Section 300-d Highway Law	
24-A	Chemung Flats County Road 9	Q 2100 to Q 6700	Bridge	0.08	County Chemung		
24-B	Chemung Flats County Road 9	Q 6700 to Q 11200	" " " "	0.09	County Chemung		
24-C	Chemung Flats County Road 9	Q 11200 to Q 14100	Destroyed by Construction	0.06	County Chemung		
24-D	Chemung Flats County Road 9	Q 14100 to Q 18100	Abandon and Remove	0.03	County Chemung		
24-E	Chemung Flats County Road 9	Q 18100 to Q 23100	Destroyed by Construction	0.03	County Chemung		
24-F	Chemung Flats County Road 9	Q 23100 to Q 23150	Abandon and Remove	0.10	County Chemung		
24-G	Chemung Flats County Road 9	Q 23150 to Q 31150	Destroyed by Construction	0.15	County Chemung		
24-H	Chemung Flats County Road 9	Q 31150 to Q 33100	Abandon and Remove	0.07	County Chemung		
25	Baker Road T R 283	TR 283-2100 to TR 283 2100	Destroyed by Construction	0.06	Town Chemung		
25-A	Baker Road T R 283	TR 283-2100 to TR 283 4160	Abandon and Remove	0.03	Town Chemung		
25-B	Baker Road T R 283	TR 283-4160 to TR 283 9110	Destroyed by Construction	0.09	Town Chemung		
25-C	Baker Road T R 283	TR 283-9110 to TR 283 11150	Abandon and Remove Bridge	0.05	Town Chemung		
SNOW REMOVAL							
26	Southern Tier Expressway Ramp B Ramp D Ramp C Ramp E County Road 9 Route 421 (SH 1760)	Stationing and mileage as listed on part Nos 1, 1-E, 1-F, 1-G, 1-H, 1-I & B	Pavement on part Nos. 1, 1-E, 1-F, 1-G, 1-H & I		State	Section 300-d Highway Law	
27	Turnaround Route 17 Connector F VOID Connector K VOID Connector G VOID Route 17 Turnaround-Chemung Flats Rd. City Rd. CONNECTOR V	Stationing and mileage as listed on part Nos. 6, 3, 4, 5, 10 & 11	Pavement on part Nos. 6, 3, 4, 5, 10 & 11		County Chemung	Section 300-d Highway Law	
28	Turnaround-Passmore Road TR 490 Wyness Creek Road Turnaround-Baker Road TR 283	Stationing and mileage as listed on part Nos. 6, 9, 11 & 13	Pavement on part Nos. 6, 9, 9, 11 & 13		Town Chemung	Section 300-d Highway Law	
<p>Note: 1) All existing sanitary sewers and other sewers not deemed to be part of the project by the Superintendent, water mains, hydrants and other municipally or privately owned facilities within the limits of the highway ROW which remain in service unchanged and all such facilities relocated or parts thereof as a part of the work performed under this project, whether temporary, located within or adjacent to the ROW, shall be maintained as the case may be, by the municipality or by the agency or unit having or having control and jurisdiction thereof at an own expense to the state.</p> <p>2) The portion of driveways or private roads constructed or adjusted under the project between the edge of pavement and the ditch or gutter line shall be maintained by the state. The remaining portion of the adjusted driveway or private road beyond the ditch or gutter line shall be maintained by the owner(s) under Section 39-A of the Highway Law. Also entrance stairs and walks shall be maintained by the owner(s) under Section 39-A of the Highway Law.</p>							

In Charge: ANP
 Made by: ANP
 Checked by: ANP
 Drawn by: ANP
 Checked by: ANP

REVISIONS
I. SNOW REMOVAL

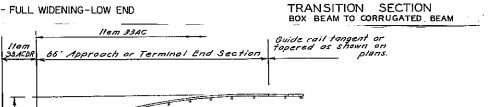
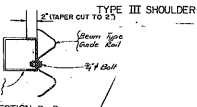
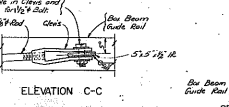
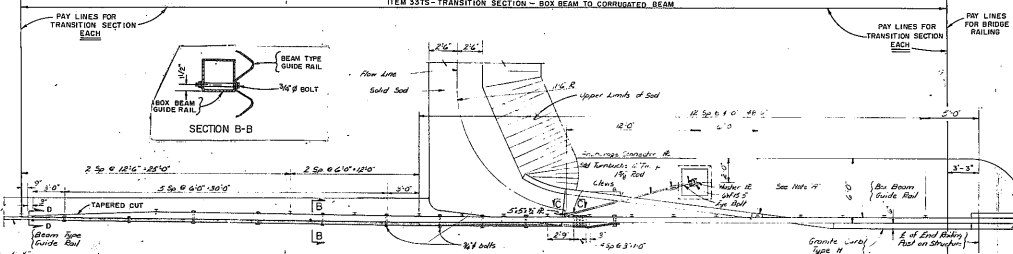
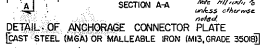
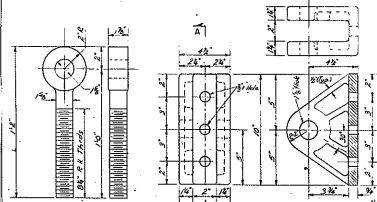
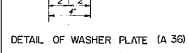
Prepared and recommended by: G. W. WOODS
 Consulting Engineer
 Date: 4/1/79

SWG. NO.	SCALE	DATE	WORKING & OREA CONSULTING ENGINEERS
M-5		4/1/79	

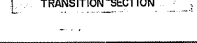
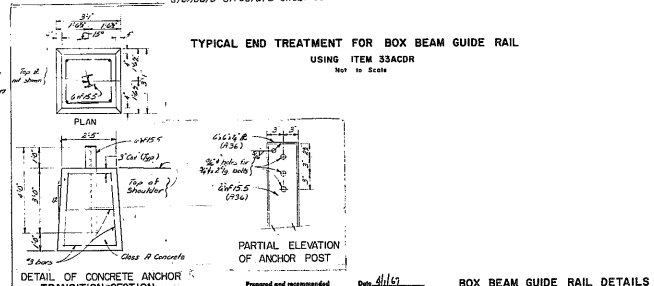
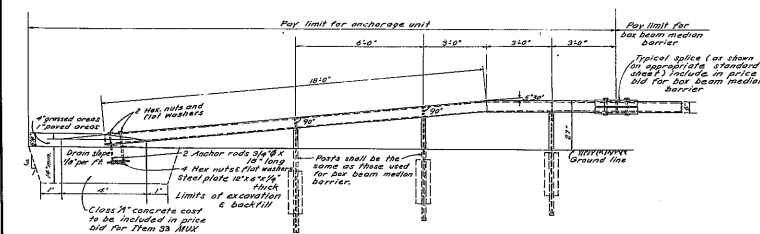
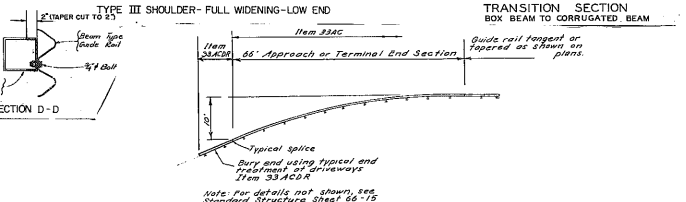
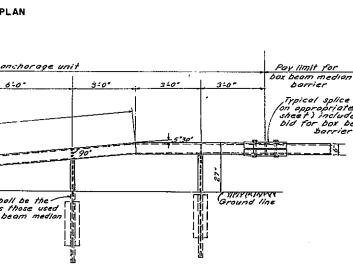
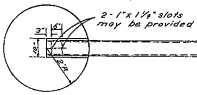


FED. ROAD DIST. NO.	STATE	FED. AID PROJ. NO.	FISCAL YEAR	SHEET NO.	TOTAL SHEETS
1	N.Y.	APD 221 (21)	77	2,00	

SOUTHERN TIER EXPRESSWAY SECTION 6R
LOWMAN - WAVERLY PART 1
CHEWING COUNTY



Notes:
 Strength of fittings in the connection between the Box Beam Guide Rail and the Concrete Abutment shall be as follows: The Clarks, 1/2" dia. Turnbuckle and Eye Bolt shall have a minimum tensile strength of 80,000 p.s.i.



Proposed and recommended
 GOODING & O'DEA
 Consulting Engineers

DRG. NO.	SCALE	DATE	GOODING & O'DEA CONSULTING ENGINEERS
T-10	As Shown	4/1/77	

SUMMARY OF HIGHWAY QUANTITIES

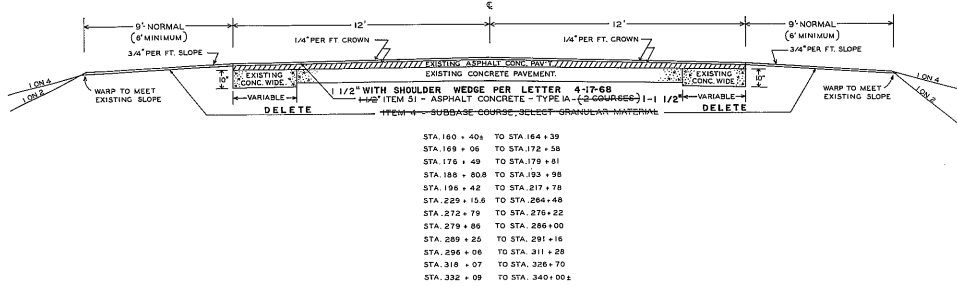
ITEM NO.	DESCRIPTION	UNIT	FINAL NEW	PROPOSAL	ITEM NO.	DESCRIPTION	UNIT	FINAL NEW	PROPOSAL
1	CLEARING AND GRUBBING	L.S.	100%	NEC.	30	MISCELLANEOUS METALS	Lb.	488.32	820
1A	CLEARING AND GRUBBING MOBILIZATION	ACRE	5	NEC.	300F	FRAMES AND GRATES - FABRICATED AND CASTINGS	S.F.	48.10	70
1W	FURNISHING WATER EQUIPMENT	L.S.	466.00%	NEC.	30F	FRAMES AND GRATES - FABRICATED AND CASTINGS	S.F.	399.5	400
1W	APPLYING WATER	M.Gal.	9,103.5	3320A	3320A	ANCHORAGE UNITS FOUR CORN. BEAM TYPE GUIDE RAILING	L.F.	49.5	14
2	UNCLASSIFIED EXCAVATION	C.Y.	3,255,000	3320C	3320C	ANCHORAGE UNITS FOUR CORN. BEAM TYPE GUIDE RAILING	L.F.	33,517.00	37,700
2A	UNCLASSIFIED EXCAVATION SELECTED FILL	C.Y.	480,281	3320C	3320C	ANCHORAGE UNITS FOUR CORN. BEAM TYPE GUIDE RAILING	L.F.	300,988	280,290
2C-BX	UNCLASSIFIED EXCAVATION SELECTED FILL	C.Y.	54,070.00	51,900	33AC	CORNUATED BEAM TYPE GUIDE RAILING	L.F.	6,209.90	5,145
2F-B	SELECTED GRANULAR FILL	C.Y.	11,800	33AGD	33AGD	CORNUATED BEAM TYPE GUIDE RAILING	L.F.	44,799	44,788
2F	UNDERDRAIN FILTER	C.Y.	158.94	100	33BU	BOX-BEAM GUIDE RAIL END ASSEMBLY	L.F.	21.39	15.39
3	SURFACE COURSE, GRANULAR MATERIAL	C.Y.	61,000	33BUA	33BUA	BOX-BEAM MEDIUM BARRIER END ASSEMBLY	L.F.	1,072.3	6,350
4	SURFACE COURSE, SELECT GRANULAR MATERIAL	C.Y.	41,016	33BUB	33BUB	BOX-BEAM MEDIUM BARRIER END ASSEMBLY	L.F.	49.5	488
5T	TRENCH AND CULVERT EXCAVATION	C.Y.	6,396	46	33TS	TRANSITION SECTION-BOX BEAM TO CORRUGATED BEAM	EA.	8	8
6	LABORATORY BUILDING	EA.	2	47AB	455P	BASE COURSE ASPHALT CONCRETE TYPE 1A	TON	2,958.56	7,590
68A	CONCRETE CYLINDER CURING BOX	EA.	2	51	46	CONCRETE FOUNDATION FOR PAVEMENT	C.Y.	23,029.29	240
6C-C	ENGINEER'S OFFICE (TYPE C)	L.S.	NEC. 200%	NEC.	594W	CEMENT CONCRETE PAVEMENT	C.Y.	10,484	29,020
7	TRIMMING ROAD SECTION	S.F. RD.	50,360	60S	60S	ASPHALT CONCRETE TYPE 1A	TON	2,830.01	8,300
8	PREPARING FINE GRADE	S.F.	133,430	70B	70B	BITUMINOUS STABILIZED COURSE (INCLUDING SHOULDERS)	C.Y.	7,830.78	8,889
11E51B	GALVANIZED METAL END SECTIONS, 18" DIA.	EA.	4	2	70H	BITUMINOUS STABILIZED COURSE (INCLUDING SHOULDERS)	S.Y.	75,420	75,420
11E52A	GALVANIZED METAL END SECTIONS, 24" DIA.	EA.	20	44	76	MAINTENANCE AND PROTECTION OF TRAFFIC (REQUIREMENT C)	L.S.	100%	NEC.
11E53D	GALVANIZED METAL END SECTIONS, 30" DIA.	EA.	1,824.8	4	76X	MAINTENANCE AND PROTECTION OF TRAFFIC ON SECTIONS OPENED TO TRAFFIC PRIOR TO ACCEPTANCE	L.M.C.D.	380	320
11H6	PERFORATED CORRUGATED METAL PIPE UNDERDRAIN, 6" DIA.	L.F.	895	830	830	MEDIUM STONE FILLING	C.Y.	448.67	460
11-B	ROUND CORRUGATED METAL PIPE, 8" DIA.	L.F.	190	190	78B	HEAVY STONE FILLING	C.Y.	3,201.8	2,080
11F18	ROUND CORRUGATED METAL PIPE, PAVED INVERT, 18" DIA. 16 GA.	L.F.	574	90	78C	GROUDED RIP-RAP	C.Y.	88,68.49	50
11F24B	ROUND CORRUGATED METAL PIPE, PAVED INVERT, 24" DIA. 16 GA.	L.F.	1,590	1,530	80A	REMOVING EXISTING SUPERSTRUCTURES	L.S.	NEC.	NEC.
11F24C	ROUND CORRUGATED METAL PIPE, PAVED INVERT, 24" DIA. 16 GA.	L.F.	384	390	81A	TEMPORARY SHEET PILING	S.F.	14,444	11,150
11F30	ROUND CORRUGATED METAL PIPE, PAVED INVERT, 30" DIA. 16 GA.	L.F.	76	80	83TX	CONCRETE GUTTERS	S.Y.	60	70
11F30B	ROUND CORRUGATED METAL PIPE, PAVED INVERT, 30" DIA. 12 GA.	L.F.	516	530	98	ASPHALT CONCRETE GUTTERS	TON	69	70
1277	ELONGATED CORRUGATED STRUCTURAL PLATE PIPE, 72" DIA. 10 GA.	L.F.	240	250	98H	CATCH BASINS	L.F.	31.67	40
12B9	ELONGATED CORRUGATED STRUCTURAL PLATE PIPE, 84" DIA. 12 GA.	L.F.	442	450	102AR	REINFORCED CONCRETE PIPE CLASS IV, 18" DIA.	L.F.	150.03	210
14-18	REINFORCED CONCRETE PIPE CLASS IV, 18" DIA.	L.F.	975.3	650	102B	REINFORCED CONCRETE PIPE CLASS IV, 24" DIA.	L.F.	2,538.348	2,980.974
14-24	REINFORCED CONCRETE PIPE CLASS IV, 24" DIA.	L.F.	1,826.234	1,740.844	104H	RIGHT-OF-WAY MARKERS TYPE H	EA.	148	160
14S18	REINFORCED CONCRETE PIPE END SECTIONS, 18" DIA.	EA.	3	1	104X	PERMANENT SURVEY MARKERS	EA.	6,374.19	4
14S24	REINFORCED CONCRETE PIPE END SECTIONS, 24" DIA.	EA.	10	11	106HS	CHAIN LINK FENCING, 6 FT. HIGH	L.F.	2,656.00	5,990
14S30	REINFORCED CONCRETE PIPE END SECTIONS, 30" DIA.	EA.	2	2	106H4	RIGHT-OF-WAY FENCING, 4 FT. HIGH	L.F.	4,460	61,470
14S412	END SECTIONS - OPTIONAL, 12" DIA.	EA.	4	2	106H6	CHAIN LINK AND WOOD SCREEN FENCING, 6 FT. HIGH	L.F.	2,410.00	350
14W12	CULVERT PIPE - OPTIONAL, 12" DIA.	L.F.	96	46	50	TEMPORARY WIRE FENCE	L.F.	80	210
14W18	REINFORCED CONCRETE PIPE CLASS IV, 18" DIA. DELETE	C.Y.	NEC.	NEC.	113B	HIGHWAY BARRICADE, 6 WF TYPE POSTS	L.F.	60	70
14W24	REINFORCED CONCRETE PIPE CLASS IV, 24" DIA. DELETE	C.Y.	NEC.	NEC.	116	STAKEOUT SURVEY	L.S.	100%	NEC.
14W30	REINFORCED CONCRETE PIPE CLASS IV, 30" DIA. DELETE	C.Y.	NEC.	NEC.	120DS	DISPOSAL OF BUILDINGS	L.S.	NEC.	NEC.
16	FURNISHING AND APPLYING CALCIUM CHLORIDE	TON	84.2	100	121	TOPSOIL PLACED FROM STOCKPILES	C.Y.	30,844	33,050
20	CLASS 9 CONCRETE FOR STRUCTURES	C.Y.	16,781.66	17	123	SEEDING	ACRE	18.87	181
25	METAL REINFORCEMENT FOR CONCRETE PAVEMENT	S.Y.P.	114,000	127S	127S	PLANTING, ELAEGANUS UMBELLATA	L.F.	1,363.00	8,514
25U	METAL REINFORCEMENT FOR CONCRETE PAVEMENT	S.Y.P.	1,660	213	213	WOOD HIGHWAY BARRICADE	EA.	1,450	1,450
27	TRANSVERSE JOINT SUPPORTS	L.F. JT.	17,066	51Z	51Z	ASPHALT CONCRETE (TOP COURSE)	TON	3,412.00	4,100
27L	LONGITUDINAL JOINT TIES	EA.	13,346	55B	55B	SURFACE COURSE FOR STABILIZED SHOULDERS (SINGLE SURFACE TREATMENT)	S.Y.	71,736.16	69,570
28	BAR REINFORCEMENT FOR STRUCTURES	Lb.	78	98	47AC	CEMENT CONCRETE PAVEMENT	C.Y.	20,000.0	—
					116A	STAKEOUT SURVEY	C.Y.	100%	—

REVISIONS
1. SUMMARY OF HIGHWAY QUANTITIES

No Change
 Checked by: *[Signature]*
 Date: *[Date]*

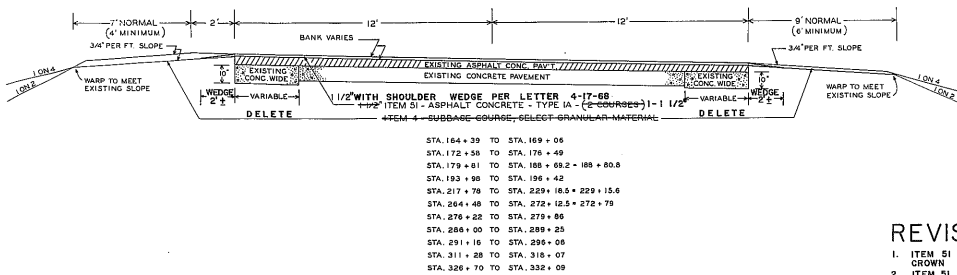
FED. RD. DIST. NO.	STATE	FEDERAL AID PROJECT NO.	SHEET NO.	TOTAL SHEETS
1	NEW YORK		19R1	199
LOWMAN-WAVERLY PART I				S.H.521B
SOUTHERN TIER EXPRESSWAY				
TYPICAL SECTIONS				

TYPICAL NORMAL CROWN SECTION



(NOT TO SCALE)

TYPICAL SUPERELEVATED SECTION



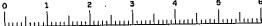
(NOT TO SCALE)

REVISIONS

1. ITEM 51 (TYPICAL NORMAL CROWN SECTION)
2. ITEM 51 (TYPICAL SUPERELEVATED SECTION)

IN CHARGE OF _____
DESIGNED BY _____
ESTIMATE BY _____
CHECKED BY *B. H. H. H.* V. *S. L. C. H. H.*

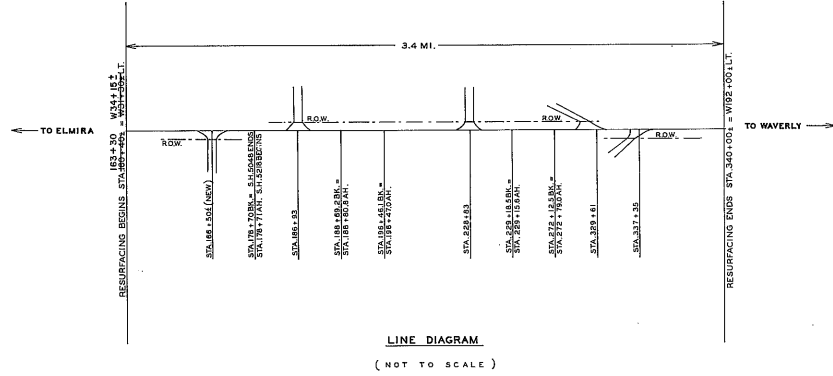
PREPARED PURSUANT TO THE HIGHWAY LAW & RECOMMENDED
BY *[Signature]* DISTRICT ENGINEER, DIST. NO. 4
19



FED. RD. DIST. NO.	STATE	FEDERAL AID PROJECT NO.	SHEET NO.	TOTAL SHEETS
1	NEW YORK		20/R/	19/3
LOWMAN-WAVERLY PART I			S.H. 5218	
SOUTHERN TIER EXPRESSWAY				
LINE DIAGRAM & TABLE OF LENGTHS				

LOWMAN - WAVERLY PT.

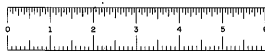
LOWMAN - WAVERLY PART I		
TABLE OF LENGTHS		
STATION	LENGTH	REMARKS
W 34+15 1/2 LT.		RESURFACING BEGINS
W 34+30+00	1540.0'	
163+30		S.H. 5048 ENDS
178+70		S.H. 5218 BEGINS
178+71	998.2'	
186+69.2 BR.		EQUALITY
188+80.8 AH.	765.3'	
196+46.1 DR.		EQUALITY
196+47.0 AH.	3271.5'	
229+18.0 BR.		EQUALITY
229+18.0 AH.	4296.9'	
272+12.5 BR.		EQUALITY
272+12.5 AH.	6721.0'	
340+00		RESURFACING ENDS
W 192+00 1/2 LT.		
TOTAL	17592.9'	3.3
TOTAL RESURFACING	17092.9'	LT. = 3.09 MILES



REVISIONS
TABLE OF LENGTHS
2. LINE DIAGRAM BEGINS STA.

IN CHARGE OF _____
DESIGNED BY _____ V _____
ESTIMATE BY _____ V _____
TRACED BY *E. J. Kelly* V *E. J. Kelly*

PREPARED IN ACCORDANCE WITH THE HIGHWAY LAW & RECOMMENDED
BY *[Signature]* DISTRICT ENGINEER, DIST. NO. 6
APR 10 1937



F.A.S.T.E. 67-4

FED. ROAD DIST. NO.	STATE	FED. AID PROJ. NO.	FISCAL YEAR	SHEET NO.	TOTAL SHEETS
1	N.Y.	APD 221-(21)	21	200	200

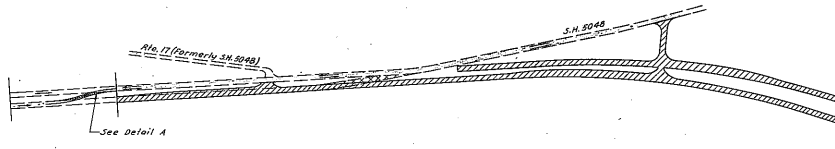
MAINTENANCE OF TRAFFIC PLAN AT BEGINNING OF PROJECT

STAGE I Traffic

Permanent Construction

Remove

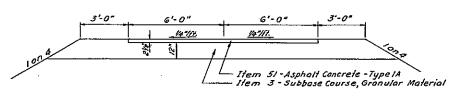
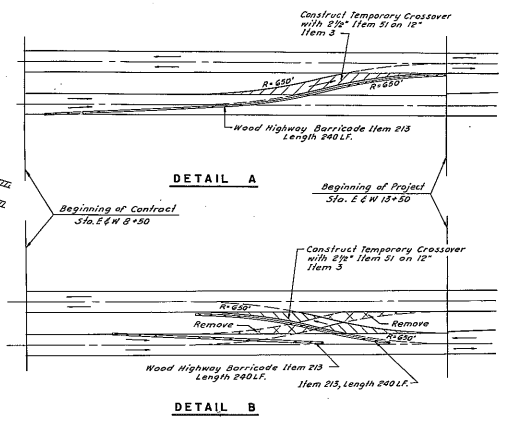
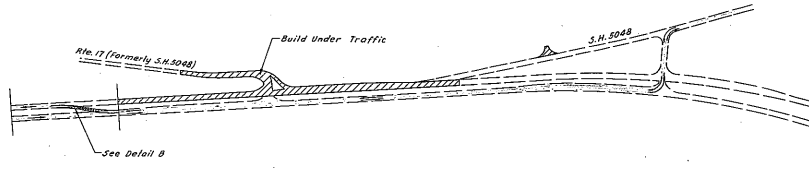
Temporary Crossover



STAGE II Traffic

Permanent Construction

Temporary Crossover



TEMPORARY ROAD

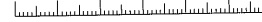
Checked by: *[Signature]*
 Drawn by: *[Signature]*
 Date: *[Date]*

Prepared and recommended by: *[Signature]*
 SPOONING & O'DEA Consulting Engineers

Date: 4/1/27

SUGGESTED MAINTENANCE OF TRAFFIC PLAN

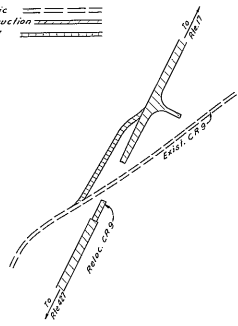
SWS. NO.	SCALE	DATE	GOODKIND & O'DEA CONSULTING ENGINEERS
NT-1	None	4/1/27	



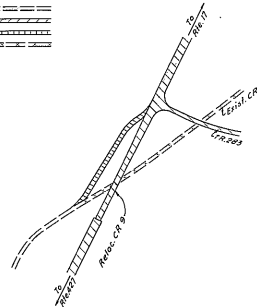
FED. AID PROJ. NO.	STATE	FED. AID PROJ. NO.	FISCAL YEAR	SHEET NO.	TOTAL SHEETS
1	N.Y.			21/31	199

SOUTHERN TIER EXPRESSWAY SECTION 6R
LOWNAH - WILVERLY PART I
CHEMUNG COUNTY

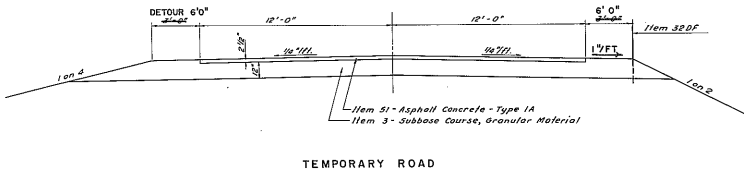
STAGE I Traffic
Permanent Construction
Temporary Road



STAGE II Traffic
Permanent Construction
Temporary Road
Remove



- STAGE I
- Traffic on Existing CR 9
 - Construct Relocated CR 9 from AS3+50.1 to Rte. 17 and from AS3+50.1 to Rte. 427.
 - Construct Temporary Road from AS3+2, Relocated CR 9, to Existing CR 9.
- STAGE II
- Traffic on Relocated CR 9, from Rte. 17 to Temporary Rd. Thence via Existing CR 9 to Rte. 427.
 - Complete remainder Relocated CR 9.
- STAGE III
- Traffic on Relocated CR 9.
 - Remove Temporary Road and remainder of former CR 9.



TEMPORARY ROAD

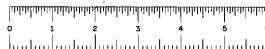
REVISIONS
I. TYPICAL SECTION TEMPORARY ROAD

In charge of: A.S.P.
Made by: A.S.P.
Checked by: A.S.P.
Drawn by: A.S.P.
Checked by: A.S.P.

Prepared and recommended by: A.S.P.
GOODENO & ODEA
Consulting Engineers

RELOC. CR 9
SUGGESTED
MAINTENANCE OF TRAFFIC PLAN

DWS. NO.	SCALE	DATE	GOODENO & ODEA CONSULTING ENGINEERS
MT-2	None	4/17	



FED. ROAD REG. NO.	STATE	FED. AID PROJ. NO.	FISCAL YEAR	SHEET NO.	TOTAL SHEETS
1	N.Y.	APD 221(21)		22	200
SOUTHERN TIER EXPRESSWAY SECTION ER LOWMAN - WAVERLY PART I CHEMUNG COUNTY					

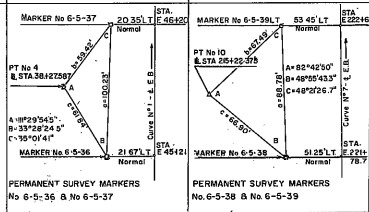
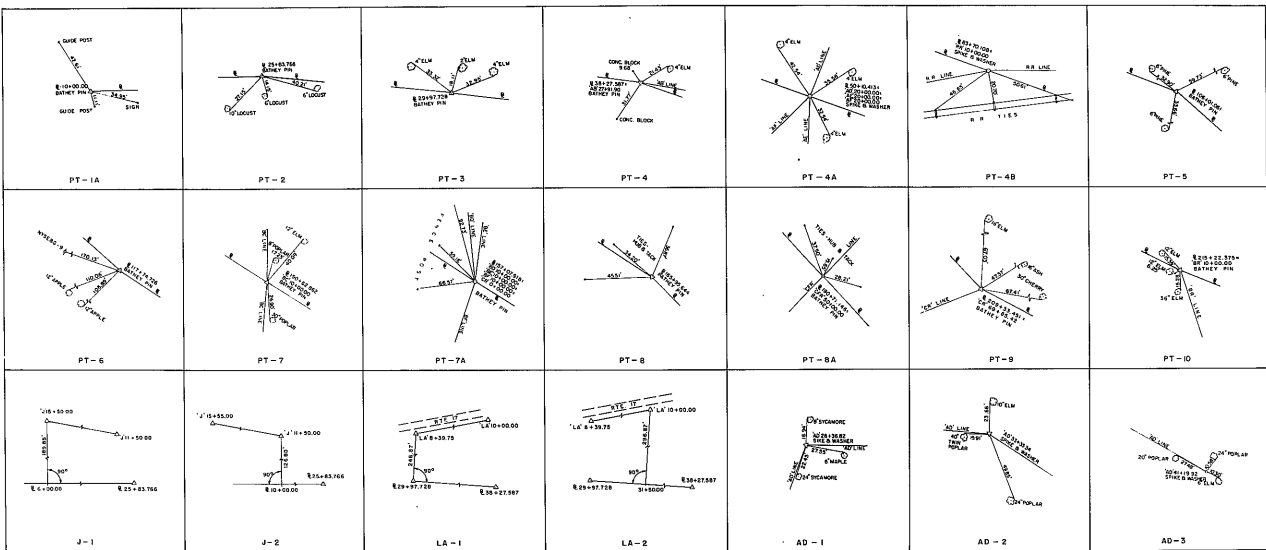
SURVEY BASE LINE COORDINATE SCHEDULE			
MONUMENT	B. L. STATION	NORTH	EAST
MAIN BASE LINE			
PT-1	6+00.00	738,721.574	471,449.561
PT-1A	10+00.00	738,729.843	471,859.175
PT-2	25+83.766	738,762.589	473,332.402
PT-3	29+97.228	738,723.031	473,864.670
PT-4	38+27.587	738,628.966	474,869.173
PT-4A	48+51.30		
PT-4A	50+10.413	738,228.132	475,782.033
PT-4B	62+00.00		
PT-4B	67+00.00		
PT-4B	73+70.00	737,089.812	478,942.095
PT-5	106+01.061	736,333.866	481,041.985
PT-6	117+76.726	735,567.644	481,921.024
PT-7	150+62.862	733,747.081	484,682.352
PT-7A	157+07.918	733,418.558	485,225.148
PT-8	165+95.644		
PT-8A	190+71.146	732,918.920	485,972.145
PT-9	200+33.151	729,284.899	488,950.184
PT-10	215+22.375	729,524.806	489,478.561
PT-11	225+79.259	729,161.877	490,471.176
AUXILIARY BASE LINES			
J-1	15+55.00	738,911.383	471,445.337
J-2	11+50.00	738,856.615	471,846.554
LA-1	8+39.75	738,968.307	473,872.670
LA-2	10+00.00	739,000.714	474,029.630
AD-1A	24+50.00	738,647.649	475,944.837
ADA	0+00.00		
AD-1	26+36.82	738,821.814	476,012.426
AD-2	33+35.34	738,869.087	476,709.344
AD-3	41+19.92	738,540.546	477,821.823
ADA-1	5+50.00	738,448.667	476,457.980
AE-1	8+40.75	737,428.923	474,942.316
AE-1	8+52.40	737,081.476	475,735.511
RA-1	4+93.97	736,996.819	478,445.469
RA-2	18+19.55	737,097.058	479,762.812

BENCH MARK SCHEDULE			
NUMBER	B. L. STATION	OFFSET	ELEVATION
BM-1	10+00	76' LT.	819.45
BM-2	18+43	60' LT.	815.16
BM-3	28+33	91' RT.	810.49
BM-4	39+62	5' LT.	817.78
BM-5	48+53	5' LT.	820.02
BM-6	59+28	22' RT.	824.22
BM-7	69+48	29' LT.	830.08
BM-N-7	83+46	2' RT.	810.17
BM-8	98+73	8' LT.	843.43
BM-9	109+82	44' LT.	844.98
BM-10	124+32	24' LT.	818.92
BM-11	134+24	133' LT.	802.43
BM-12	150+81	21' RT.	799.16
BM-13	156+34	128' RT.	795.95
BM-14	165+95.644	-	797.80
BM-15	179+35	457' LT.	796.94
BM-16	190+42	555' LT.	798.41
BM-17	201+09	199' LT.	796.83
BM-18	209+97	20' LT.	797.87
BM-19	215+18	2' RT.	816.36

17

Prepared and recommended by: *[Signature]*
 Date: 9/20/17
 Consulting Engineers

TABLES			
DWG. NO.	SCALE	DATE	GOODKIND & O'DEA CONSULTING ENGINEERS
S-1		9/20/17	



REVISIONS
1 PERMANENT SURVEY MARKERS ADDITION

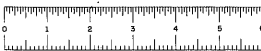
Proposed and recommended

 GOODENO & O'DEA
 Consulting Engineers

SURVEY BASE LINE TIES

DWG. NO.	SCALE	DATE	GOODENO & O'DEA - CONSULTING ENGINEERS
S-2	No Scale	4/1/64	

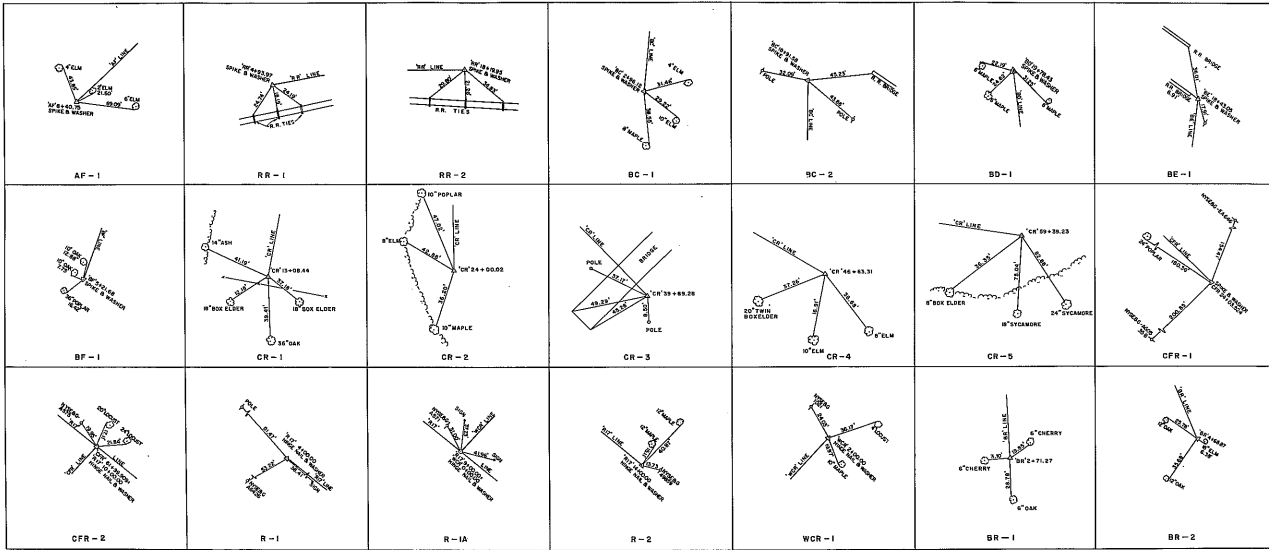
As Checked by: J. J. O'Dea
 Drawn by: J. J. O'Dea
 Checked by: J. J. O'Dea
 Date: 4/1/64



F.A.C.T.E. 67-4

FED. ROAD REC. NO.	STATE	FED. AID PROG. NO.	FISCAL YEAR	SHEET NO.	TOTAL SHEETS
1	N.Y.	APD 221 (21)	20	200	

SOUTHERN TIER EXPRESSWAY SECTION 6R
LOWMAN - WAVERLY PART I
CHEMUNG COUNTY



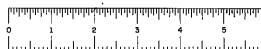
Checked by: A. J. B.
 Drawn by: A. J. B.
 Date: 4/1/47

Prepared and recommended
ALON W. B. B.
 Consulting Engineers

Date: 4/1/47

SURVEY BASE LINE TIES

DWG. NO.	SCALE	DATE	GOODKIND & ODEA CONSULTING ENGINEERS
5-3	No. Scale	4/1/47	



FED. ROAD REG. NO.	STATE	FED. AID PROJ. NO.	FISCAL YEAR	SHEET NO.	TOTAL SHEETS
1	N.Y.	APD 221(41)	76	200	
SOUTHERN TIER EXPRESSWAY SECTION 6R LOWMAN - WAVERLY PART I CHEMUNG COUNTY					

SCHEDULE OF ALIGNMENT CONTROL POINT TIES TO SURVEY BASELINE									
EASTBOUND		WESTBOUND		STATION		STATION		STATION	
REG. PROJ.	STA. STATION	REG. PROJ.	STA. STATION	STATION	STATION	STATION	STATION	STATION	STATION
E 1350.000	600.697R	W 1350.000	599.661L	W1200.000	1340.565L	W1200.000	1340.565L	W1200.000	1340.565L
E 1400.000	650.487R	E12400.000	11864.457R	W 1400.000	649.653L	W12400.000	11603.277L	W12400.000	11603.277L
E 1600.000	850.444R	E12600.000	11884.403R	W 1600.000	849.608L	W12600.000	11823.716L	W12600.000	11823.716L
E 1800.000	1050.600R	E12800.000	12084.370R	W 1800.000	1049.566L	W12800.000	12023.686L	W12800.000	12023.686L
E 2000.000	1250.558R	E13000.000	12284.335R	W 2000.000	1249.523L	W13000.000	12223.654L	W13000.000	12223.654L
E 2200.000	1450.515R	E13200.000	12484.300R	W 2200.000	1449.481L	W13200.000	12423.623L	W13200.000	12423.623L
E 2400.000	1650.472R	E13400.000	12684.265R	W 2400.000	1649.437L	W13400.000	12623.591L	W13400.000	12623.591L
E 2600.000	1850.429R	E13600.000	12884.230R	W 2600.000	1849.394L	W13600.000	12823.559L	W13600.000	12823.559L
E 2800.000	2050.386R	E13800.000	13084.195R	W 2800.000	2049.351L	W13800.000	13023.527L	W13800.000	13023.527L
E 3000.000	2250.343R	E14000.000	13284.160R	W 3000.000	2249.308L	W14000.000	13223.495L	W14000.000	13223.495L
E 3200.000	2450.300R	E14200.000	13484.125R	W 3200.000	2449.265L	W14200.000	13423.463L	W14200.000	13423.463L
E 3214.000	2464.279R	E14400.000	13684.100R	PC	W 3214.000	2464.279R	W14400.000	13623.431L	W14400.000
E 3400.000	2649.800R	E14600.000	13884.072R	W 3400.000	2649.800L	W14600.000	13823.399L	W14600.000	13823.399L
E 3600.000	2849.757R	E14800.000	14084.047R	W 3600.000	2849.757L	W14800.000	14023.367L	W14800.000	14023.367L
E 3800.000	3049.714R	E15000.000	14284.022R	W 3800.000	3049.714L	W15000.000	14223.335L	W15000.000	14223.335L
E 4000.000	3249.671R	E15200.000	14484.000R	W 4000.000	3249.671L	W15200.000	14423.303L	W15200.000	14423.303L
E 4200.000	3449.628R	E15400.000	14684.000R	W 4200.000	3449.628L	W15400.000	14623.271L	W15400.000	14623.271L
E 4400.000	3649.585R	E15600.000	14884.000R	W 4400.000	3649.585L	W15600.000	14823.239L	W15600.000	14823.239L
E 4600.000	3849.542R	E15800.000	15084.000R	W 4600.000	3849.542L	W15800.000	15023.207L	W15800.000	15023.207L
E 4627.504	3883.868R	E16000.000	15284.000R	PT	W 4627.504	3883.868R	W16000.000	15223.175L	W16000.000
E 4800.000	4049.520R	E16200.000	15484.000R	W 4800.000	4049.520L	W16200.000	15423.143L	W16200.000	15423.143L
E 5000.000	4249.477R	E16400.000	15684.000R	W 5000.000	4249.477L	W16400.000	15623.111L	W16400.000	15623.111L
E 5200.000	4449.434R	E16600.000	15884.000R	W 5200.000	4449.434L	W16600.000	15823.079L	W16600.000	15823.079L
E 5400.000	4649.391R	E16800.000	16084.000R	W 5400.000	4649.391L	W16800.000	16023.047L	W16800.000	16023.047L
E 5600.000	4849.348R	E17000.000	16284.000R	W 5600.000	4849.348L	W17000.000	16223.015L	W17000.000	16223.015L
E 5800.000	5049.305R	E17200.000	16484.000R	W 5800.000	5049.305L	W17200.000	16423.000L	W17200.000	16423.000L
E 6000.000	5249.262R	E17400.000	16684.000R	W 6000.000	5249.262L	W17400.000	16623.000L	W17400.000	16623.000L
E 6200.000	5449.219R	E17600.000	16884.000R	W 6200.000	5449.219L	W17600.000	16823.000L	W17600.000	16823.000L
E 6400.000	5649.176R	E17800.000	17084.000R	W 6400.000	5649.176L	W17800.000	17023.000L	W17800.000	17023.000L
E 6500.000	5659.800R	E18000.000	17132.830R	W 6500.000	5659.800L	W18000.000	17072.830L	W18000.000	17072.830L
E 6800.000	6059.051R	E18200.000	17332.830R	W 6800.000	6059.051L	W18200.000	17272.830L	W18200.000	17272.830L
E 7000.000	6259.008R	E18400.000	17532.830R	W 7000.000	6259.008L	W18400.000	17472.830L	W18400.000	17472.830L
E 7200.000	6459.000R	E18600.000	17732.830R	W 7200.000	6459.000L	W18600.000	17672.830L	W18600.000	17672.830L
E 7400.000	6659.000R	E18800.000	17932.830R	W 7400.000	6659.000L	W18800.000	17872.830L	W18800.000	17872.830L
E 7600.000	6859.000R	E19000.000	18132.830R	W 7600.000	6859.000L	W19000.000	18072.830L	W19000.000	18072.830L
E 7800.000	7059.000R	E19200.000	18332.830R	W 7800.000	7059.000L	W19200.000	18272.830L	W19200.000	18272.830L
E 8000.000	7259.000R	E19400.000	18532.830R	W 8000.000	7259.000L	W19400.000	18472.830L	W19400.000	18472.830L
E 8200.000	7459.000R	E19600.000	18732.830R	W 8200.000	7459.000L	W19600.000	18672.830L	W19600.000	18672.830L
E 8400.000	7659.000R	E19800.000	18932.830R	W 8400.000	7659.000L	W19800.000	18872.830L	W19800.000	18872.830L
E 8600.000	7859.000R	E20000.000	19132.830R	W 8600.000	7859.000L	W20000.000	19072.830L	W20000.000	19072.830L
E 8800.000	8059.000R	E20200.000	19332.830R	W 8800.000	8059.000L	W20200.000	19272.830L	W20200.000	19272.830L
E 9000.000	8259.000R	E20400.000	19532.830R	W 9000.000	8259.000L	W20400.000	19472.830L	W20400.000	19472.830L
E 9200.000	8459.000R	E20600.000	19732.830R	W 9200.000	8459.000L	W20600.000	19672.830L	W20600.000	19672.830L
E 9400.000	8659.000R	E20800.000	19932.830R	W 9400.000	8659.000L	W20800.000	19872.830L	W20800.000	19872.830L
E 9600.000	8859.000R	E21000.000	20132.830R	W 9600.000	8859.000L	W21000.000	20072.830L	W21000.000	20072.830L
E 9800.000	9059.000R	E21200.000	20332.830R	W 9800.000	9059.000L	W21200.000	20272.830L	W21200.000	20272.830L
E 9850.472	9061.204R	E21400.000	20532.830R	PC	W 9850.472	9061.204R	W21400.000	20472.830L	W21400.000
E10000.000	9259.000R	E21600.000	20732.830R	W 10000.000	9259.000L	W21600.000	20672.830L	W21600.000	20672.830L
E10200.000	9459.000R	E21800.000	20932.830R	W 10200.000	9459.000L	W21800.000	20872.830L	W21800.000	20872.830L
E10400.000	9659.000R	E22000.000	21132.830R	W 10400.000	9659.000L	W22000.000	21072.830L	W22000.000	21072.830L
E10600.000	9859.000R	E22200.000	21332.830R	W 10600.000	9859.000L	W22200.000	21272.830L	W22200.000	21272.830L
E10800.000	10059.000R	E22400.000	21532.830R	W 10800.000	10059.000L	W22400.000	21472.830L	W22400.000	21472.830L
E11000.000	10259.000R	E22600.000	21732.830R	W 11000.000	10259.000L	W22600.000	21672.830L	W22600.000	21672.830L
E11200.000	10459.000R	E22800.000	21932.830R	W 11200.000	10459.000L	W22800.000	21872.830L	W22800.000	21872.830L
E11347.061	10787.454R	E23000.000	22132.830R	PT	W 11347.061	10787.454R	W23000.000	22072.830L	W23000.000
E11400.000	10987.411R	E23200.000	22332.830R	W 11400.000	10987.411L	W23200.000	22272.830L	W23200.000	22272.830L
E11600.000	11187.368R	E23400.000	22532.830R	W 11600.000	11187.368L	W23400.000	22472.830L	W23400.000	22472.830L
E11800.000	11387.325R	E23600.000	22732.830R	W 11800.000	11387.325L	W23600.000	22672.830L	W23600.000	22672.830L
E12000.000	11587.282R	E23800.000	22932.830R	W 12000.000	11587.282L	W23800.000	22872.830L	W23800.000	22872.830L
E12200.000	11787.239R	E24000.000	23132.830R	W 12200.000	11787.239L	W24000.000	23072.830L	W24000.000	23072.830L
E12400.000	11987.196R	E24200.000	23332.830R	W 12400.000	11987.196L	W24200.000	23272.830L	W24200.000	23272.830L
E12600.000	12187.153R	E24400.000	23532.830R	W 12600.000	12187.153L	W24400.000	23472.830L	W24400.000	23472.830L
E12800.000	12387.110R	E24600.000	23732.830R	W 12800.000	12387.110L	W24600.000	23672.830L	W24600.000	23672.830L
E13000.000	12587.067R	E24800.000	23932.830R	W 13000.000	12587.067L	W24800.000	23872.830L	W24800.000	23872.830L
E13200.000	12787.024R	E25000.000	24132.830R	W 13200.000	12787.024L	W25000.000	24072.830L	W25000.000	24072.830L
E13400.000	12987.000R	E25200.000	24332.830R	W 13400.000	12987.000L	W25200.000	24272.830L	W25200.000	24272.830L
E13600.000	13187.000R	E25400.000	24532.830R	W 13600.000	13187.000L	W25400.000	24472.830L	W25400.000	24472.830L
E13800.000	13387.000R	E25600.000	24732.830R	W 13800.000	13387.000L	W25600.000	24672.830L	W25600.000	24672.830L
E14000.000	13587.000R	E25800.000	24932.830R	W 14000.000	13587.000L	W25800.000	24872.830L	W25800.000	24872.830L
E14200.000	13787.000R	E26000.000	25132.830R	W 14200.000	13787.000L	W26000.000	25072.830L	W26000.000	25072.830L
E14400.000	13987.000R	E26200.000	25332.830R	W 14400.000	13987.000L	W26200.000	25272.830L	W26200.000	25272.830L
E14600.000	14187.000R	E26400.000	25532.830R	W 14600.000	14187.000L	W26400.000	25472.830L	W26400.000	25472.830L
E14800.000	14387.000R	E26600.000	25732.830R	W 14800.000	14387.000L				

FIELD CHANGE

FED. ROAD PROJ. NO.	STATE	FEDERAL AID PROJECT NO.	SHEET NO.	TOTAL SHEETS
1	M.X.	APD 221 (21)	28	199
SOUTHERN TIER EXPRESSWAY SECTION 6R				
LOWMAN - WAVERLY PART I				
CHEMUNG COUNTY				

TABLE OF GUIDE RAILING

STATION TO STATION	SIDE	33DA L.F.	33DA SA	33AC L.F.	33ACDR SA	33MU L.F.	33MUA EA	STATION TO STATION	SIDE	33DA L.F.	33DA SA	33AC L.F.	33ACDR SA	33MU L.F.	33MUA EA
<p>ITEM 33 DA - CORRUGATED BEAM TYPE GUIDE RAILING ITEM 33 DDA - ANCHORAGE UNITS FOR CORRUGATED BEAM TYPE GUIDE RAILING ITEM 33 DDA - BOX BEAM GUIDE RAIL END ASSEMBLY ITEM 33 ACOR - BOX BEAM MEDIAN BARRIER END ASSEMBLY ITEM 33 MU - BOX BEAM MEDIAN BARRIER END ASSEMBLY ITEM 33 MUA - BOX BEAM MEDIAN BARRIER END ASSEMBLY</p>															
<p>RELOC. COUNTY ROAD 9 A10+45 - A10+52 RT. 936.1 2 A10+52 - A11+00 RT. 936.2 2 A11+00 - A11+52 RT. 130.5 1 A11+52 - A24+26 RT. 146.5 1 A19+93 - A24+26 RT. 437.6 1 A20+00 - A23+16 RT. 550.0 1 A21+20 - A23+75 RT. 325.1 1 A24+26 - A29+75 RT. 325.1 1</p>															
<p>RAMP D A31+00 - A33+50 RT. 250.1 1 A30+80 - A33+50 RT. 262.6 1 A36+85 - A38+75.3 RT. 179.3 1 A37+00 - A38+67.2 RT. 167.2 1 A38+97 - A41+97 RT. 200.1 1 A40+00 - A42+05 RT. 212.6 1 A44+75 - A46+24 RT. 170.5 1 A44+86 - A46+40 RT. 170.5 1</p>															
<p>RAMP B B12+15 - B31+35 RT. 1825.5 1 B27+90 - B31+50 RT. 363.2 1 B31+50 - B31+84.34 RT. 66.5 1 B31+85 - B31+84.34 RT. 99.6 1</p>															
<p>RAMP C C10+80 - C28+80 RT. 1600.0 1 C10+29 - C10+85 RT. 83.3 1 C10+29 - C10+80 RT. 99.6 1 C10+85 - C13+00 RT. 237.6 1</p>															
<p>RAMP D D10+75 - D30+79 RT. 1989.2 1 D10+29 - D12+54 RT. 99.6 1 D10+29 - D10+75 RT. 99.6 1</p>															
<p>RAMP E E10+00 - E28+77 RT. 1879.0 1 E28+07 - E29+26 RT. 187.0 1 E28+77 - E29+26 RT. 93.1 1</p>															
<p>RELOC. T.R. 283 G10+29 - G10+70 RT. 99.6 1 G10+70 - G19+65 RT. 900.4 1 G20+50 - G24+60 RT. 412.6 2 G25+50 - G42+60 RT. 1882.0 2 G10+75 - G34+20 RT. 2337.6 1 G10+29 - G10+75 RT. 99.6 1</p>															
<p>RELOC. RT. 17 I7+00 - I23+20 RT. 637.8 2</p>															
<p>TOTAL NEAT 33,576.3 17 6,209.6 21 1,872.3 4</p> <p>TOTAL PROPOSAL 35,700 14 7,140 16 2,350 4</p>															

NOTE: ITEM 33TS-TRANSITION SECTION - BOX BEAM TO CORRUGATED WILL BE USED AS FOLLOWS:

STATION	SIDE	STATION	SIDE	STATION	SIDE
E45+94	RT.	W154+33	LT.	A20+62	RT.
W50+72	LT.	E154+93	RT.	A33+47	RT.
E60+12	RT.	W164+94	LT.	A33+52	LT.
E84+11	RT.	E165+08	RT.	A41+88	RT.
W60+92	LT.	W86+52	LT.	A42+05	LT.

NOTE: GUIDE RAILING SHALL BE INSTALLED IN ACCORDANCE WITH THE TABLE ABOVE AND NOT AS SHOWN ON THE 1"=50' SCALE PLANS

TABLE OF ITEM 104H
RIGHT OF WAY MARKERS

LOCATION	SIDE	EACH
RELOCATED RT. 17	RT.	7
RELOCATED RT. 17	LT.	7
EASTBOUND	RT.	22
WESTBOUND	LT.	33
RAMP E	RT.	7
RAMP D	RT.	1
RAMP B	RT.	1
RAMP C	RT.	1
ROUTE 427	LT.	1
WYNCOOP ROAD	LT.	2
WYNCOOP ROAD	RT.	2
RELOC. T.R. 283	RT.	9
RELOC. T.R. 283	LT.	2
RECON. RT. 17	LT.	5
RECON. RT. 17	RT.	8
CHANNEL IMPROV. M	RT.	7
CHANNEL IMPROV. T	LT.	2
CHANNEL IMPROV. N	LT.	10
RELOC. C.R. 9	LT.	11
RELOC. C.R. 9	RT.	15
TOTAL NEAT		151
TOTAL PROPOSAL		160

TABLE OF ITEM 104X
PERMANENT SURVEY MARKERS

LOCATION	SIDE	EACH
MAINLINE		
EASTBOUND ROADWAY	RT.	2
WESTBOUND ROADWAY	LT.	2
TOTAL NEAT		4
TOTAL PROPOSAL		4

TABLE OF FENCING

STATION TO STATION	SIDE	106MS6 L.F.	106R L.F.	106SW6 L.F.
<p>ITEM 106MS6 - CHAIN LINK FENCING - 6' HIGH ITEM 106R - RIGHT OF WAY FENCING - 4' HIGH ITEM 106SW6 - CHAIN LINK AND WOOD SCREEN FENCING 6' HIGH</p>				
<p>MAINLINE</p>				
E15+50	RT.	1,290.9	4102.3	
W29+39	RT.			735.0
W39+60	RT.			854.6
W49+44	RT.			1,118.0
E41+50	RT.			3,172.5
E59+09	RT.			3,728.9
W59+62	RT.			7,476.2
E92+16	RT.			2,533.3
W100+54	RT.			2,070.7
E163+83	RT.			4,808.2
W143+80	RT.			894.0
W125+05	RT.			71.0
W120+80	RT.			79.0
<p>SIDERoads</p>				
RAMP B, B18+00 - B30+75	RT.	1,734.3		
C.R. 9 A27+88 - A24+88	LT.			1,073.5
RAMP D, D18+93 - D11+50	LT.			102.5
C.R. 9 A24+82 - G11+30	RT.			711.2
C.R. 9 G11+30 - A27+83	RT.			1,435.0
T.R. 283 G11+30 - G17+67	LT.			2,467.0
C.R. 9 A43+20 - A43+50	LT.			172.8
C.R. 9 A42+65 - A43+00	RT.			156.4
<p>RELOC. RT. 17</p>				
14+70 - 19+00	RT.			446.2
21+24 - W29+39	LT.			328.9
14+00 - 21+25	LT.			357.4
* E196+25 - W197+20				174.0
TOTAL NEAT		6,374.1	34,564.7	
TOTAL PROPOSAL		5,990	41,470	350

* USED AS TEMPORARY ROAD BARRICADE FOR E.B. & W.B. WILL BE REMOVED WHEN NEXT SECTION IS OPENED

THIS SHEET DELETES ALL OF SHEET NO. 28

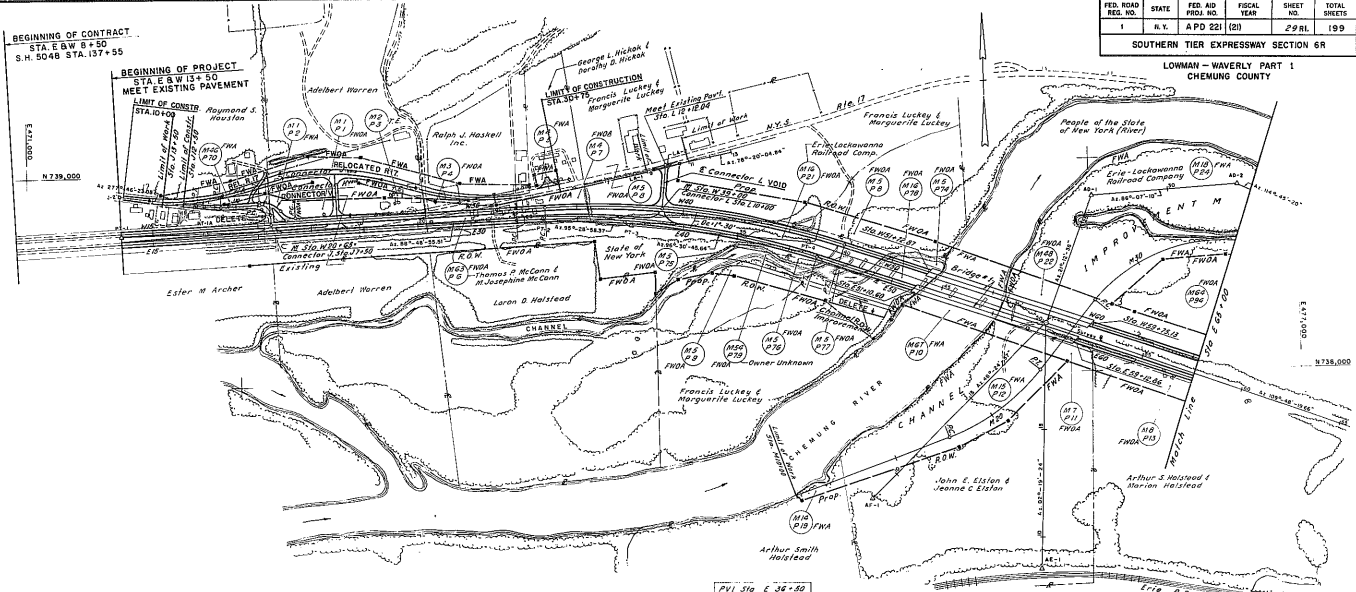
TABLES

DWG. NO.	SCALE	DATE	GOODKIND & O'DEA CONSULTING ENGINEERS (INCORPORATED)
5-7			

FED. ROAD DIST. NO.	STATE	FED. AID PROJ. NO.	FISCAL YEAR	SHEET NO.	TOTAL SHEETS
1	N.Y.	A PD 221	(20)	29 RL	199

SOUTHERN TIER EXPRESSWAY SECTION 6R

LOWMAN - WAVERLY PART 1
CHEMUNG COUNTY



BEGINNING OF CONTRACT
STA. E & W 8+50
S.H. 5048 STA. 137+55

BEGINNING OF PROJECT
STA. E & W 13+50
MEET EXISTING PAVEMENT

PVI STA. E & W 24+00
Elev. 822.25
LVC 400'
MG 0.40'
SSD 378'

PVI STA. E & W 30+00
Elev. 800.88
LVC 400'
MG 0.40'
SSD 378'

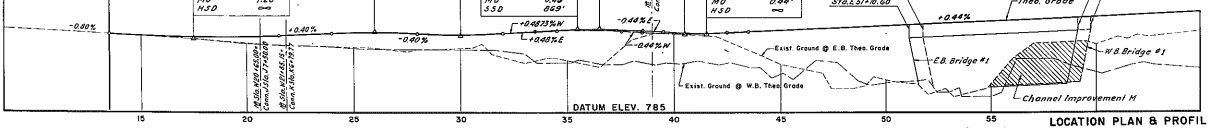
PVI STA. E & W 35+50
Elev. 823.57
LVC 400'
MG 0.46'
SSD 376'

PVI STA. E & W 40+50
Elev. 851.33
LVC 400'
MG 0.40'
SSD 378'

PVI STA. E & W 41+50
Elev. 851.75
LVC 400'
MG 0.40'
SSD 378'

REVISIONS

1. RELOCATED R.I.T ALIGNMENTS
2. ADDITION OF CONNECTOR V.
3. DELETE CONNECTORS J, K & L.
4. ROW MONUMENTS ON REL. R.I.T AREA
5. RT. OF SW. ABUT. BRDG. N.1



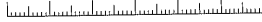
LOCATION PLAN & PROFILE
STA. 8+50 TO STA. 65+00

Proposed and recommended
GODKIND & O'DEA
Consulting Engineers

Date: 4/1/67
Consulting Engineers

DWG. NO.	SCALE	DATE	ENGINEER
L-1	1"=20'	4/1/67	GODKIND & O'DEA CONSULTING ENGINEERS

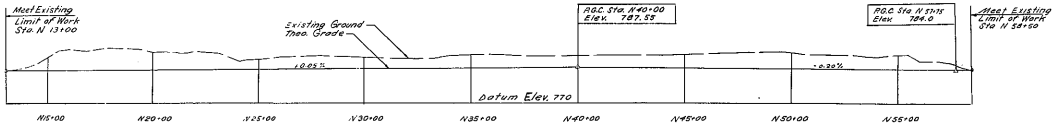
No. 1000
 No. 1001
 No. 1002
 No. 1003
 No. 1004
 No. 1005
 No. 1006
 No. 1007
 No. 1008
 No. 1009
 No. 1010
 No. 1011
 No. 1012
 No. 1013
 No. 1014
 No. 1015
 No. 1016
 No. 1017
 No. 1018
 No. 1019
 No. 1020
 No. 1021
 No. 1022
 No. 1023
 No. 1024
 No. 1025
 No. 1026
 No. 1027
 No. 1028
 No. 1029
 No. 1030
 No. 1031
 No. 1032
 No. 1033
 No. 1034
 No. 1035
 No. 1036
 No. 1037
 No. 1038
 No. 1039
 No. 1040
 No. 1041
 No. 1042
 No. 1043
 No. 1044
 No. 1045
 No. 1046
 No. 1047
 No. 1048
 No. 1049
 No. 1050
 No. 1051
 No. 1052
 No. 1053
 No. 1054
 No. 1055
 No. 1056
 No. 1057
 No. 1058
 No. 1059
 No. 1060
 No. 1061
 No. 1062
 No. 1063
 No. 1064
 No. 1065
 No. 1066
 No. 1067
 No. 1068
 No. 1069
 No. 1070
 No. 1071
 No. 1072
 No. 1073
 No. 1074
 No. 1075
 No. 1076
 No. 1077
 No. 1078
 No. 1079
 No. 1080
 No. 1081
 No. 1082
 No. 1083
 No. 1084
 No. 1085
 No. 1086
 No. 1087
 No. 1088
 No. 1089
 No. 1090
 No. 1091
 No. 1092
 No. 1093
 No. 1094
 No. 1095
 No. 1096
 No. 1097
 No. 1098
 No. 1099
 No. 1100
 No. 1101
 No. 1102
 No. 1103
 No. 1104
 No. 1105
 No. 1106
 No. 1107
 No. 1108
 No. 1109
 No. 1110
 No. 1111
 No. 1112
 No. 1113
 No. 1114
 No. 1115
 No. 1116
 No. 1117
 No. 1118
 No. 1119
 No. 1120
 No. 1121
 No. 1122
 No. 1123
 No. 1124
 No. 1125
 No. 1126
 No. 1127
 No. 1128
 No. 1129
 No. 1130
 No. 1131
 No. 1132
 No. 1133
 No. 1134
 No. 1135
 No. 1136
 No. 1137
 No. 1138
 No. 1139
 No. 1140
 No. 1141
 No. 1142
 No. 1143
 No. 1144
 No. 1145
 No. 1146
 No. 1147
 No. 1148
 No. 1149
 No. 1150
 No. 1151
 No. 1152
 No. 1153
 No. 1154
 No. 1155
 No. 1156
 No. 1157
 No. 1158
 No. 1159
 No. 1160
 No. 1161
 No. 1162
 No. 1163
 No. 1164
 No. 1165
 No. 1166
 No. 1167
 No. 1168
 No. 1169
 No. 1170
 No. 1171
 No. 1172
 No. 1173
 No. 1174
 No. 1175
 No. 1176
 No. 1177
 No. 1178
 No. 1179
 No. 1180
 No. 1181
 No. 1182
 No. 1183
 No. 1184
 No. 1185
 No. 1186
 No. 1187
 No. 1188
 No. 1189
 No. 1190
 No. 1191
 No. 1192
 No. 1193
 No. 1194
 No. 1195
 No. 1196
 No. 1197
 No. 1198
 No. 1199
 No. 1200
 No. 1201
 No. 1202
 No. 1203
 No. 1204
 No. 1205
 No. 1206
 No. 1207
 No. 1208
 No. 1209
 No. 1210
 No. 1211
 No. 1212
 No. 1213
 No. 1214
 No. 1215
 No. 1216
 No. 1217
 No. 1218
 No. 1219
 No. 1220
 No. 1221
 No. 1222
 No. 1223
 No. 1224
 No. 1225
 No. 1226
 No. 1227
 No. 1228
 No. 1229
 No. 1230
 No. 1231
 No. 1232
 No. 1233
 No. 1234
 No. 1235
 No. 1236
 No. 1237
 No. 1238
 No. 1239
 No. 1240
 No. 1241
 No. 1242
 No. 1243
 No. 1244
 No. 1245
 No. 1246
 No. 1247
 No. 1248
 No. 1249
 No. 1250
 No. 1251
 No. 1252
 No. 1253
 No. 1254
 No. 1255
 No. 1256
 No. 1257
 No. 1258
 No. 1259
 No. 1260
 No. 1261
 No. 1262
 No. 1263
 No. 1264
 No. 1265
 No. 1266
 No. 1267
 No. 1268
 No. 1269
 No. 1270
 No. 1271
 No. 1272
 No. 1273
 No. 1274
 No. 1275
 No. 1276
 No. 1277
 No. 1278
 No. 1279
 No. 1280
 No. 1281
 No. 1282
 No. 1283
 No. 1284
 No. 1285
 No. 1286
 No. 1287
 No. 1288
 No. 1289
 No. 1290
 No. 1291
 No. 1292
 No. 1293
 No. 1294
 No. 1295
 No. 1296
 No. 1297
 No. 1298
 No. 1299
 No. 1300
 No. 1301
 No. 1302
 No. 1303
 No. 1304
 No. 1305
 No. 1306
 No. 1307
 No. 1308
 No. 1309
 No. 1310
 No. 1311
 No. 1312
 No. 1313
 No. 1314
 No. 1315
 No. 1316
 No. 1317
 No. 1318
 No. 1319
 No. 1320
 No. 1321
 No. 1322
 No. 1323
 No. 1324
 No. 1325
 No. 1326
 No. 1327
 No. 1328
 No. 1329
 No. 1330
 No. 1331
 No. 1332
 No. 1333
 No. 1334
 No. 1335
 No. 1336
 No. 1337
 No. 1338
 No. 1339
 No. 1340
 No. 1341
 No. 1342
 No. 1343
 No. 1344
 No. 1345
 No. 1346
 No. 1347
 No. 1348
 No. 1349
 No. 1350
 No. 1351
 No. 1352
 No. 1353
 No. 1354
 No. 1355
 No. 1356
 No. 1357
 No. 1358
 No. 1359
 No. 1360
 No. 1361
 No. 1362
 No. 1363
 No. 1364
 No. 1365
 No. 1366
 No. 1367
 No. 1368
 No. 1369
 No. 1370
 No. 1371
 No. 1372
 No. 1373
 No. 1374
 No. 1375
 No. 1376
 No. 1377
 No. 1378
 No. 1379
 No. 1380
 No. 1381
 No. 1382
 No. 1383
 No. 1384
 No. 1385
 No. 1386
 No. 1387
 No. 1388
 No. 1389
 No. 1390
 No. 1391
 No. 1392
 No. 1393
 No. 1394
 No. 1395
 No. 1396
 No. 1397
 No. 1398
 No. 1399
 No. 1400
 No. 1401
 No. 1402
 No. 1403
 No. 1404
 No. 1405
 No. 1406
 No. 1407
 No. 1408
 No. 1409
 No. 1410
 No. 1411
 No. 1412
 No. 1413
 No. 1414
 No. 1415
 No. 1416
 No. 1417
 No. 1418
 No. 1419
 No. 1420
 No. 1421
 No. 1422
 No. 1423
 No. 1424
 No. 1425
 No. 1426
 No. 1427
 No. 1428
 No. 1429
 No. 1430
 No. 1431
 No. 1432
 No. 1433
 No. 1434
 No. 1435
 No. 1436
 No. 1437
 No. 1438
 No. 1439
 No. 1440
 No. 1441
 No. 1442
 No. 1443
 No. 1444
 No. 1445
 No. 1446
 No. 1447
 No. 1448
 No. 1449
 No. 1450
 No. 1451
 No. 1452
 No. 1453
 No. 1454
 No. 1455
 No. 1456
 No. 1457
 No. 1458
 No. 1459
 No. 1460
 No. 1461
 No. 1462
 No. 1463
 No. 1464
 No. 1465
 No. 1466
 No. 1467
 No. 1468
 No. 1469
 No. 1470
 No. 1471
 No. 1472
 No. 1473
 No. 1474
 No. 1475
 No. 1476
 No. 1477
 No. 1478
 No. 1479
 No. 1480
 No. 1481
 No. 1482
 No. 1483
 No. 1484
 No. 1485
 No. 1486
 No. 1487
 No. 1488
 No. 1489
 No. 1490
 No. 1491
 No. 1492
 No. 1493
 No. 1494
 No. 1495
 No. 1496
 No. 1497
 No. 1498
 No. 1499
 No. 1500
 No. 1501
 No. 1502
 No. 1503
 No. 1504
 No. 1505
 No. 1506
 No. 1507
 No. 1508
 No. 1509
 No. 1510
 No. 1511
 No. 1512
 No. 1513
 No. 1514
 No. 1515
 No. 1516
 No. 1517
 No. 1518
 No. 1519
 No. 1520
 No. 1521
 No. 1522
 No. 1523
 No. 1524
 No. 1525
 No. 1526
 No. 1527
 No. 1528
 No. 1529
 No. 1530
 No. 1531
 No. 1532
 No. 1533
 No. 1534
 No. 1535
 No. 1536
 No. 1537
 No. 1538
 No. 1539
 No. 1540
 No. 1541
 No. 1542
 No. 1543
 No. 1544
 No. 1545
 No. 1546
 No. 1547
 No. 1548
 No. 1549
 No. 1550
 No. 1551
 No. 1552
 No. 1553
 No. 1554
 No. 1555
 No. 1556
 No. 1557
 No. 1558
 No. 1559
 No. 1560
 No. 1561
 No. 1562
 No. 1563
 No. 1564
 No. 1565
 No. 1566
 No. 1567
 No. 1568
 No. 1569
 No. 1570
 No. 1571
 No. 1572
 No. 1573
 No. 1574
 No. 1575
 No. 1576
 No. 1577
 No. 1578
 No. 1579
 No. 1580
 No. 1581
 No. 1582
 No. 1583
 No. 1584
 No. 1585
 No. 1586
 No. 1587
 No. 1588
 No. 1589
 No. 1590
 No. 1591
 No. 1592
 No. 1593
 No. 1594
 No. 1595
 No. 1596
 No. 1597
 No. 1598
 No. 1599
 No. 1600
 No. 1601
 No. 1602
 No. 1603
 No. 1604
 No. 1605
 No. 1606
 No. 1607
 No. 1608
 No. 1609
 No. 1610
 No. 1611
 No. 1612
 No. 1613
 No. 1614
 No. 1615
 No. 1616
 No. 1617
 No. 1618
 No. 1619
 No. 1620
 No. 1621
 No. 1622
 No. 1623
 No. 1624
 No. 1625
 No. 1626
 No. 1627
 No. 1628
 No. 1629
 No. 1630
 No. 1631
 No. 1632
 No. 1633
 No. 1634
 No. 1635
 No. 1636
 No. 1637
 No. 1638
 No. 1639
 No. 1640
 No. 1641
 No. 1642
 No. 1643
 No. 1644
 No. 1645
 No. 1646
 No. 1647
 No. 1648
 No. 1649
 No. 1650
 No. 1651
 No. 1652
 No. 1653
 No. 1654
 No. 1655
 No. 1656
 No. 1657
 No. 1658
 No. 1659
 No. 1660
 No. 1661
 No. 1662
 No. 1663
 No. 1664
 No. 1665
 No. 1666
 No. 1667
 No. 1668
 No. 1669
 No. 1670
 No. 1671
 No. 1672
 No. 1673
 No. 1674
 No. 1675
 No. 1676
 No. 1677
 No. 1678
 No. 1679
 No. 1680
 No. 1681
 No. 1682
 No. 1683
 No. 1684
 No. 1685
 No. 1686
 No. 1687
 No. 1688
 No. 1689
 No. 1690
 No. 1691
 No. 1692
 No. 1693
 No. 1694
 No. 1695
 No. 1696
 No. 1697
 No. 1698
 No. 1699
 No. 1700
 No. 1701
 No. 1702
 No. 1703
 No. 1704
 No. 1705
 No. 1706
 No. 1707
 No. 1708
 No. 1709
 No. 1710
 No. 1711
 No. 1712
 No. 1713
 No. 1714
 No. 1715
 No. 1716
 No. 1717
 No. 1718
 No. 1719
 No. 1720
 No. 1721
 No. 1722
 No. 1723
 No. 1724
 No. 1725
 No. 1726
 No. 1727
 No. 1728
 No. 1729
 No. 1730
 No. 1731
 No. 1732
 No. 1733
 No. 1734
 No. 1735
 No. 1736
 No. 1737
 No. 1738
 No. 1739
 No. 1740
 No. 1741
 No. 1742
 No. 1743
 No. 1744
 No. 1745
 No. 1746
 No. 1747
 No. 1748
 No. 1749
 No. 1750
 No. 1751
 No. 1752
 No. 1753
 No. 1754
 No. 1755
 No. 1756
 No. 1757
 No. 1758
 No. 1759
 No. 1760
 No. 1761
 No. 1762
 No. 1763
 No. 1764
 No. 1765
 No. 1766
 No. 1767
 No. 1768
 No. 1769
 No. 1770
 No. 1771
 No. 1772
 No. 1773
 No. 1774
 No. 1775
 No. 1776
 No. 1777
 No. 1778
 No. 1779
 No. 1780
 No. 1781
 No. 1782
 No. 1783
 No. 1784
 No. 1785
 No. 1786
 No. 1787
 No. 1788
 No. 1789
 No. 1790
 No. 1791
 No. 1792
 No. 1793
 No. 1794
 No. 1795
 No. 1796
 No. 1797
 No. 1798
 No. 1799
 No. 1800
 No. 1801
 No. 1802
 No. 1803
 No. 1804
 No. 1805
 No. 1806
 No. 1807
 No. 1808
 No. 1809
 No. 1810
 No. 1811
 No. 1812
 No. 1813
 No. 1814
 No. 1815
 No. 1816
 No. 1817
 No. 1818
 No. 1819
 No. 1820
 No. 1821
 No. 1822
 No. 1823
 No. 1824
 No. 1825
 No. 1826
 No. 1827
 No. 1828
 No. 1829
 No. 1830
 No. 1831
 No. 1832
 No. 1833
 No. 1834
 No. 1835
 No. 1836
 No. 1837
 No. 1838
 No. 1839
 No. 1840
 No. 1841
 No. 1842
 No. 1843
 No. 1844
 No. 1845
 No. 1846
 No. 1847
 No. 1848
 No. 1849
 No. 1850
 No. 1851
 No. 1852
 No. 1853
 No. 1854
 No. 1855
 No. 1856
 No. 1857
 No. 1858
 No. 1859
 No. 1860
 No. 1861
 No. 1862
 No. 1863
 No. 1864
 No. 1865
 No. 1866
 No. 1867
 No. 1868
 No. 1869
 No. 1870
 No. 1871
 No. 1872
 No. 1873
 No. 1874
 No. 1875
 No. 1876
 No. 1877
 No. 1878
 No. 1879
 No. 1880
 No. 1881
 No. 1882
 No. 1883
 No. 1884
 No. 1885
 No. 1886
 No. 1887
 No. 1888
 No. 1889
 No. 1890
 No. 1891
 No. 1892
 No. 1893
 No. 1894
 No. 1895
 No. 1896
 No. 1897
 No. 1898
 No. 1899
 No. 1900
 No. 1901
 No. 1902
 No. 1903
 No. 1904
 No. 1905
 No. 1906
 No. 1907
 No. 1908
 No. 1909
 No. 1910
 No. 1911
 No. 1912
 No. 1913
 No. 1914
 No. 1915
 No. 1916
 No. 1917
 No. 1918
 No. 1919
 No. 1920
 No. 1921
 No. 1922
 No. 1923
 No. 1924
 No. 1925
 No. 1926
 No. 1927
 No. 1928
 No. 1929
 No. 1930
 No. 1931
 No. 1932
 No. 1933
 No. 1934
 No. 1935
 No. 1936
 No. 1937
 No. 1938
 No. 1939
 No. 1940
 No. 1941
 No. 1942
 No. 1943
 No. 1944
 No. 1945
 No. 1946
 No. 1947
 No. 1948
 No. 1949
 No. 1950
 No. 1951
 No. 1952
 No. 1953
 No. 1954
 No. 1955
 No. 1956
 No. 1957
 No. 1958
 No. 1959
 No. 1960
 No. 1961
 No. 1962
 No. 1963
 No. 1964
 No. 1965
 No. 1966
 No. 1967
 No. 1968
 No. 1969
 No. 1970
 No. 1971
 No. 1972
 No. 1973
 No. 1974
 No. 1



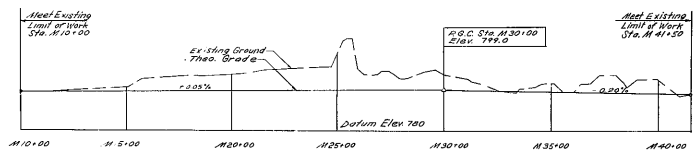
FED. ROAD REG. NO.	STATE	FED. AID PROJ. NO.	FISCAL YEAR	SHEET NO.	TOTAL SHEETS
1	N.Y.			JOR 1	199

SOUTHERN TIER EXPRESSWAY SECTION 6R

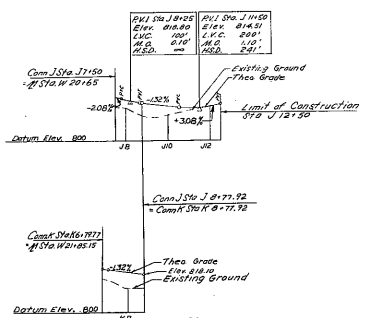
LOWMAN - WAVERLY PART 1
CHEMUNG COUNTY



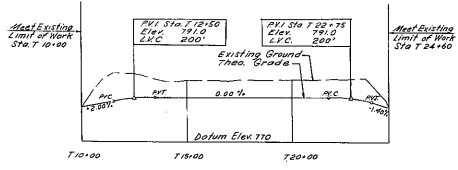
CHANNEL IMPROVEMENT N



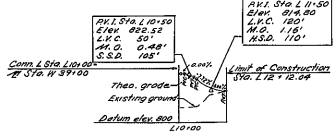
CHANNEL IMPROVEMENT M



VOID CONNECTORS J & K
REVISIONS
1. DELETE CONNECTORS J, K & L



CHANNEL IMPROVEMENT T



VOID CONNECTOR L

Prepared and recommended by
GOODKIND & ODEA

Date: 4/1/47
Consulting Engineers

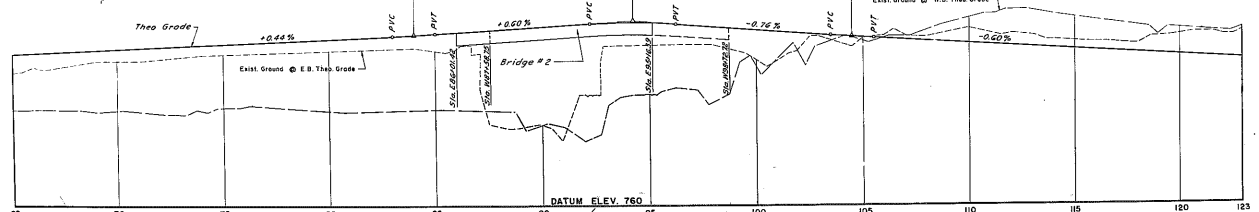
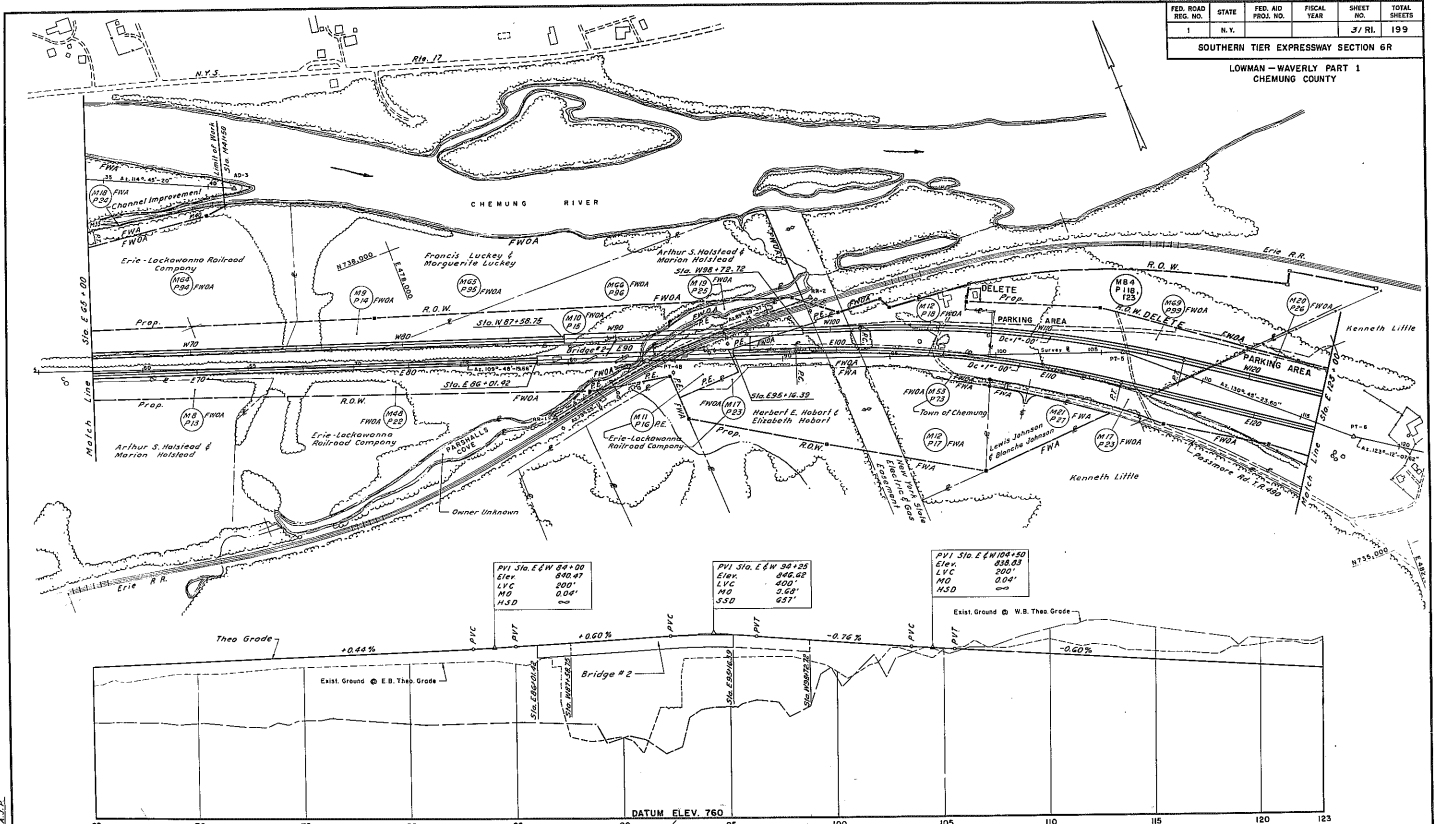
PROFILES
CHANNEL IMPROVEMENTS N, M & T
VOID CONNECTORS J & K

DWG. NO.	SCALE	DATE	GOODKIND & ODEA
L-1A	1" = 20'	4/1/47	CONSULTING ENGINEERS

FED. ROAD REC. NO.	STATE	FED. AID PROJ. NO.	FISCAL YEAR	SHEET NO.	TOTAL SHEETS
1	N.Y.			3/ RL	199

SOUTHERN TIER EXPRESSWAY SECTION 6R

LOWMAN - WAVERLY PART 1
CHEMUNG COUNTY



PVI Sta. E & W 84+00
Elev. 840.47
LVC 300'
MD 0.04'
M&D 0.04'

PVI Sta. E & W 98+25
Elev. 846.02
LVC 300'
MD 0.04'
M&D 0.04'

PVI Sta. E & W 104+50
Elev. 838.03
LVC 300'
MD 0.04'
M&D 0.04'

REVISIONS

- 1) ADDITION OF PARKING AREA
- 2) R.O.W. LINE FROM STA. W 106+40 TO STA. W 123+35 L.T.

Prepared and recommended
by *[Signature]*
GOODKIND & O'SEA
Consulting Engineers

Date: *4/1/47*
Consulting Engineer

LOCATION PLAN & PROFILE
STA. 65+00 TO STA. 123+00

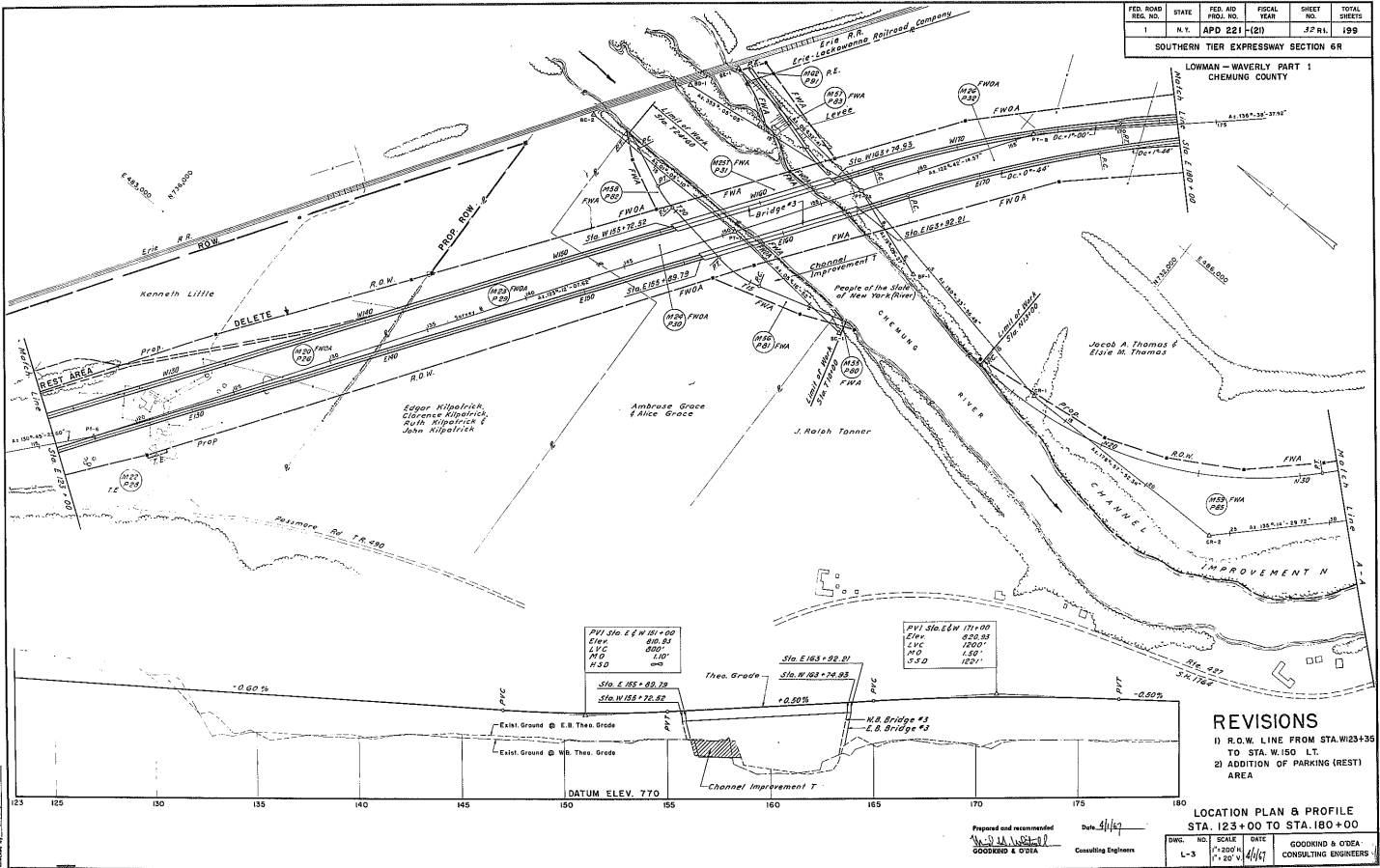
DRAW. NO.	SCALE	DATE	GOODKIND & O'SEA CONSULTING ENGINEERS
L-2	1" = 200'	4/1/47	

No. 100
 Date: 4/1/47
 Drawn by: J. J. O'SEA
 Checked by: J. J. O'SEA

FED. ROAD REG. NO.	STATE	FED. AID PROJ. NO.	FISCAL YEAR	SHEET NO.	TOTAL SHEETS
1	N.Y.	APD 221-1(2)		37	199

SOUTHERN TIER EXPRESSWAY SECTION 6R

LOWMAN - WAVERLY PART 1
CHEMUNG COUNTY



REVISIONS

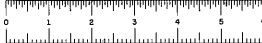
- 1) R.O.W. LINE FROM STA. W123+35 TO STA. W150 LT.
- 2) ADDITION OF PARKING (REST) AREA

LOCATION PLAN & PROFILE
STA. 123+00 TO STA. 180+00

Prepared and recommended
Date: 4/1/67
Consulting Engineers

DWG. NO.	SCALE	DATE	GOODING & ODEA
L-3	1"=200' 1"=50'	4/1/67	CONSULTING ENGINEERS

In Charge: [Signature]
 Checked By: [Signature]
 Date: 4/1/67

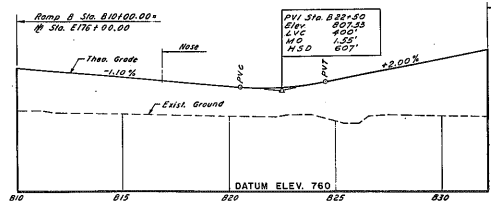


FAST 974

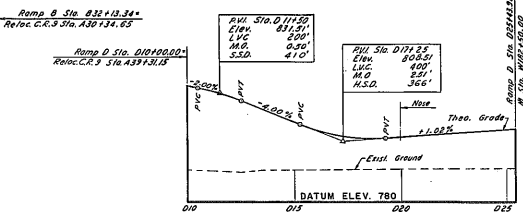
FED. ROAD DIST. NO.	STATE	FED. AID PROJ. NO.	FISCAL YEAR	SHEET NO.	TOTAL SHEETS
1	N.Y.	APD 221-211	34	200	

SOUTHERN TIER EXPRESSWAY SECTION 6R

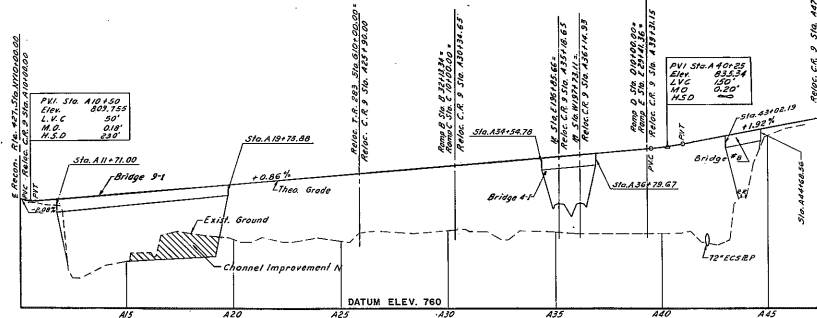
LOWMAN - WAVERLY PART 1
CHEMUNG COUNTY



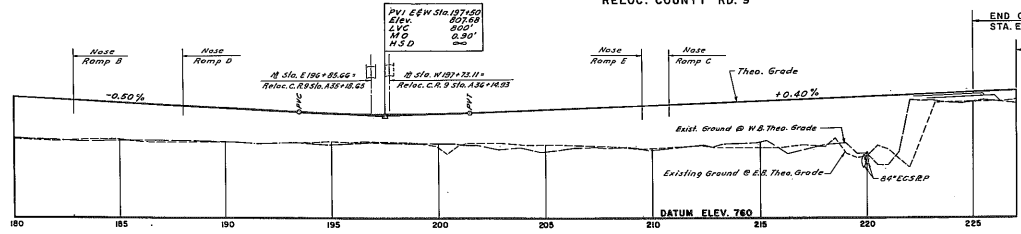
RAMP B



RAMP D



RELOC. COUNTY RD. 9



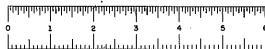
PROFILE
RELOC. C.R. 9, RAMP B & D
@ STA. 180+00 TO STA. 227+00

Proposed and recommended
 [Signature]
 CONSULTING ENGINEERS

DATE: 4/17/17

DATE	SCALE	NO.	BY
4/17/17	1"=20'	L-5	[Signature]

600020 & ODEA
CONSULTING ENGINEERS

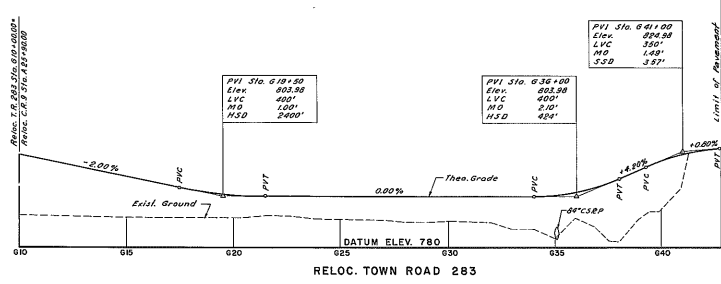
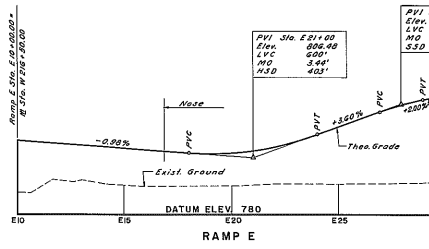
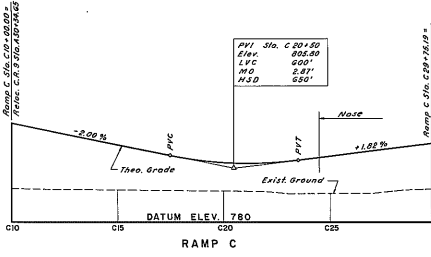


F.A.S.T.E 37-4

FED. ROAD DIST. NO.	STATE	FED. AID PROJ. NO.	FISCAL YEAR	SHEET NO.	TOTAL SHEETS
1	N.Y.	APD 221 (2)	55	35	200

SOUTHERN TIER EXPRESSWAY SECTION 6R

LOWMAN - WAVERLY PART 1
CHEMUNG COUNTY



Checked by: J.L.A.P.
 Drawn by: J.L.A.P.

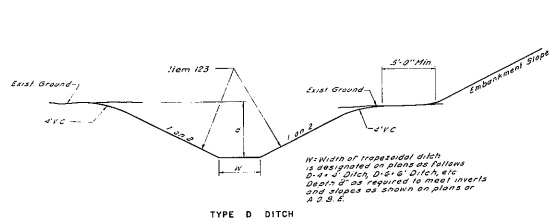
PROFILE
 RELOC. TOWN ROAD 283, RAMPS C & E

Prepared and recommended
 11-9-11
 GOODKING & O'DEA
 Consulting Engineers

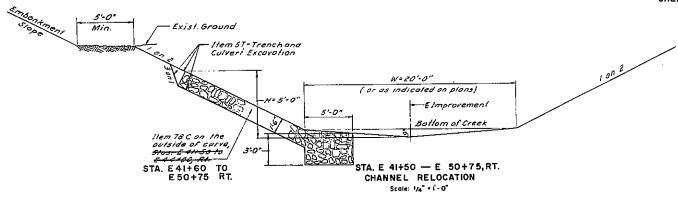
DWG. NO.	SCALE	DATE	GOODKING & O'DEA CONSULTING ENGINEERS
L-5A	1"=20'	11/9/11	

FED. ROAD DIST. NO.	STATE	FED. AID PROJ. NO.	FISCAL YEAR	SHEET NO.	TOTAL SHEETS
1	N.Y.			36 RI	199

SOUTHERN TIER EXPRESSWAY SECTION 6R
LOWMAN - WAWERLY PART 1
CHEMUNG COUNTY



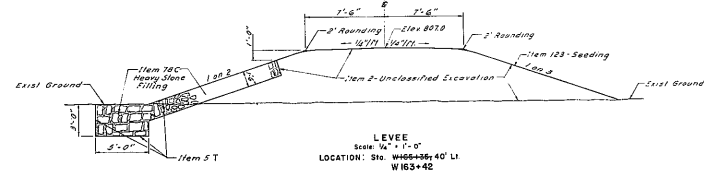
TYPE D DITCH
 Not to Scale



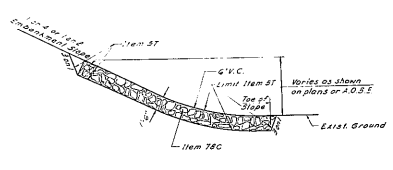
CHANNEL RELOCATION
 Scale 1/4"=1'-0"



STONE FILL LINED TYPE D DITCH
 Not to Scale

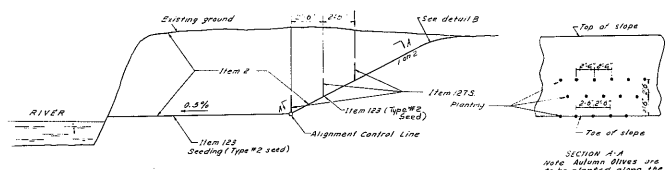


LEVEE
 Scale 1/4"=1'-0"
 LOCATION: Sta. W18+88 to W21+33, LI



DETAIL FOR STONE FILLING ON EMBANKMENT SLOPES
 Scale 1/4"=1'-0"

LOCATION: Sta. W21+83 to W221+33, LI



CHANNEL IMPROVEMENT
 Scale 1/4"=1'-0"

LOCATION: Bridge No. 1, Sta. M10+00 to M41+50
 Bridge No. 3, Sta. T10+00 to T28+50
 Bridge No. 2-1, Sta. N18+00 to N58+50

REVISIONS

- 1 CHANNEL RELOCATION
- 2 LEVEE LOCATION

DRAINAGE DETAILS

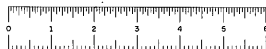
SECTION 2-A
 Note: Autumn olives are to be planted along the full length of the new channel bank slope strip where it is within the Autumn olives will be installed by the contractor without charge by the State of New York. See the Roadside Development Sheet, Drawing No. RD-1

Prepared and recommended
GOODKIND & O'DEA
 Consulting Engineers

Date: 11/17
 Consulting Engineers

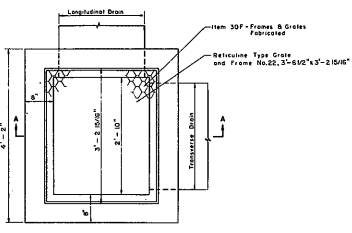
DWG. NO.	SCALE	DATE	GOODKIND & O'DEA CONSULTING ENGINEERS
D-1	As Shown	11/17	

Scale: 1/4"=1'-0"
 Date: 11/17
 Drawing No. RD-1

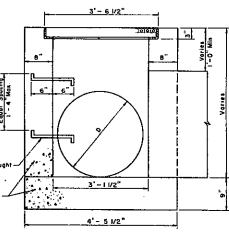


FED. ROAD DIST. NO.	STATE	FED. AID PROJ. NO.	FISCAL YEAR	SHEET NO.	TOTAL SHEETS
1	N.C.	APD 221-1011	37	200	

SOUTHERN TIER EXPRESSWAY SECTION 6R
LOWMAN - WAVERLY PART 1
CHEMUNG COUNTY

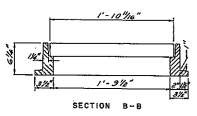


PLAN

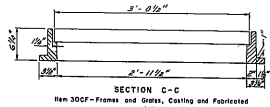


SECTION A-A

DROP INLET DETAIL
Item 1022B-Drop Inlets
Scale: 1" = 1'-0"

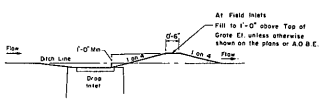


SECTION B-B

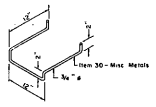


SECTION C-C

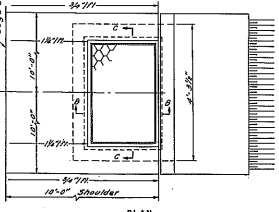
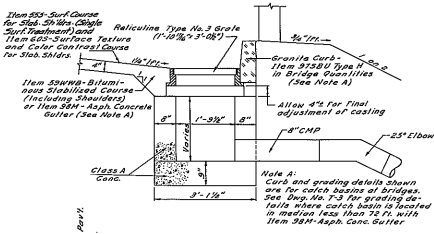
Item 1022C-Frames and Grates, Curbs and Fabricated
Scale: 1/2" = 1'-0"



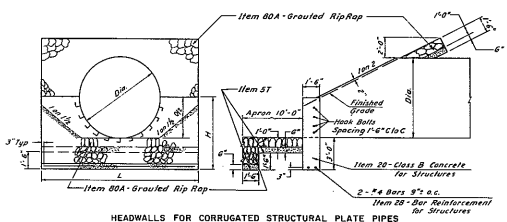
GRADING FOR DROP INLETS
Not to Scale



GALVANIZED WROUGHT IRON STEP
Item 30 - Miscellaneous Metals

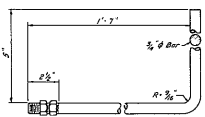


PLAN
CATCH BASIN
Item 1022A
Scale: 3/4" = 1'-0"



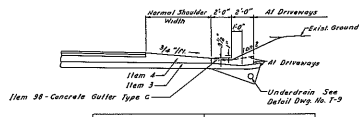
HEADWALLS FOR CORRUGATED STRUCTURAL PLATE PIPES

TYPE	ITEM	12 E
Size-D	20"	86"
H	6'-0"	82"
E	12'-0"	121 1/2"



HOOK BOLT DETAIL
Not to Scale

Note: Hook bolt must shall meet the current ASTM A-307. Threads shall be American Standard Coarse Thread Series, Class 2. Drop Pin Detail shall be guaranteed to meet current ASTM Specification A-151. The galvanizing on the heads shall not prevent turning the nut by hand. Nuts shall be carbon steel not dip galvanized to meet ASTM Specification A-153. Nut threads shall be American Standard Coarse Thread Series (5/8" max. diameter), cleaned after galvanizing to provide a free running fit on the case. Drop Nuts shall be 1/2" hex. nuts, 3/4" thick, curve crowned to approximately 1" radius.



DETAIL OF SHOULDER WITH TYPE C CONCRETE GUTTER
Scale: 1/4" = 1'-0"

NAME	STA.	TO STA.
Wynkoop Creek Road	MY 10+40	MY 12+00 L.S.

DRAINAGE DETAILS

In Charge of: S. J. P.
Made By: S. J.
Checked By: S. J.
Scale: 1" = 1'-0"

Prepared and recommended by: M. P. OGDEN & OSA
Date: 4/1/67
Consulting Engineers

DWG. NO.	SCALE	DATE	GOODKIND & ODEA CONSULTING ENGINEERS
D-2	As Shown	4/1/67	

SCHEDULE A

LOCATION AND QUANTITY OF PAYMENT ITEMS

STATION TO STATION	SIDE	ITEM UNIT	QUANTITY	REMARKS	
		10A	6.0	On areas where Item 121 is used.	
10M11+50 - 225+00	SEW	121	S.F.	24,905	
Interchange		121	S.F.	8,072	
Local Item 121	HEAV		S.F.	33,044	
		TYPE			
10M11+50 - 225+00		1	123	Acres	88.93
10M11+50 - 225+00		2	123	Acres	88.93
10M11+50 - 225+00		3	123	Acres	88.93
10M11+50 - 225+00		4	123	Acres	88.93
10M11+50 - 225+00		5	123	Acres	88.93
10M11+50 - 225+00		6	123	Acres	88.93
10M11+50 - 225+00		7	123	Acres	88.93
10M11+50 - 225+00		8	123	Acres	88.93
10M11+50 - 225+00		9	123	Acres	88.93
10M11+50 - 225+00		10	123	Acres	88.93
10M11+50 - 225+00		11	123	Acres	88.93
10M11+50 - 225+00		12	123	Acres	88.93
10M11+50 - 225+00		13	123	Acres	88.93
10M11+50 - 225+00		14	123	Acres	88.93
10M11+50 - 225+00		15	123	Acres	88.93
10M11+50 - 225+00		16	123	Acres	88.93
10M11+50 - 225+00		17	123	Acres	88.93
10M11+50 - 225+00		18	123	Acres	88.93
10M11+50 - 225+00		19	123	Acres	88.93
10M11+50 - 225+00		20	123	Acres	88.93
10M11+50 - 225+00		21	123	Acres	88.93
10M11+50 - 225+00		22	123	Acres	88.93
10M11+50 - 225+00		23	123	Acres	88.93
10M11+50 - 225+00		24	123	Acres	88.93
10M11+50 - 225+00		25	123	Acres	88.93
10M11+50 - 225+00		26	123	Acres	88.93
10M11+50 - 225+00		27	123	Acres	88.93
10M11+50 - 225+00		28	123	Acres	88.93
10M11+50 - 225+00		29	123	Acres	88.93
10M11+50 - 225+00		30	123	Acres	88.93
10M11+50 - 225+00		31	123	Acres	88.93
10M11+50 - 225+00		32	123	Acres	88.93
10M11+50 - 225+00		33	123	Acres	88.93
10M11+50 - 225+00		34	123	Acres	88.93
10M11+50 - 225+00		35	123	Acres	88.93
10M11+50 - 225+00		36	123	Acres	88.93
10M11+50 - 225+00		37	123	Acres	88.93
10M11+50 - 225+00		38	123	Acres	88.93
10M11+50 - 225+00		39	123	Acres	88.93
10M11+50 - 225+00		40	123	Acres	88.93
10M11+50 - 225+00		41	123	Acres	88.93
10M11+50 - 225+00		42	123	Acres	88.93
10M11+50 - 225+00		43	123	Acres	88.93
10M11+50 - 225+00		44	123	Acres	88.93
10M11+50 - 225+00		45	123	Acres	88.93
10M11+50 - 225+00		46	123	Acres	88.93
10M11+50 - 225+00		47	123	Acres	88.93
10M11+50 - 225+00		48	123	Acres	88.93
10M11+50 - 225+00		49	123	Acres	88.93
10M11+50 - 225+00		50	123	Acres	88.93
10M11+50 - 225+00		51	123	Acres	88.93
10M11+50 - 225+00		52	123	Acres	88.93
10M11+50 - 225+00		53	123	Acres	88.93
10M11+50 - 225+00		54	123	Acres	88.93
10M11+50 - 225+00		55	123	Acres	88.93
10M11+50 - 225+00		56	123	Acres	88.93
10M11+50 - 225+00		57	123	Acres	88.93
10M11+50 - 225+00		58	123	Acres	88.93
10M11+50 - 225+00		59	123	Acres	88.93
10M11+50 - 225+00		60	123	Acres	88.93
10M11+50 - 225+00		61	123	Acres	88.93
10M11+50 - 225+00		62	123	Acres	88.93
10M11+50 - 225+00		63	123	Acres	88.93
10M11+50 - 225+00		64	123	Acres	88.93
10M11+50 - 225+00		65	123	Acres	88.93
10M11+50 - 225+00		66	123	Acres	88.93
10M11+50 - 225+00		67	123	Acres	88.93
10M11+50 - 225+00		68	123	Acres	88.93
10M11+50 - 225+00		69	123	Acres	88.93
10M11+50 - 225+00		70	123	Acres	88.93
10M11+50 - 225+00		71	123	Acres	88.93
10M11+50 - 225+00		72	123	Acres	88.93
10M11+50 - 225+00		73	123	Acres	88.93
10M11+50 - 225+00		74	123	Acres	88.93
10M11+50 - 225+00		75	123	Acres	88.93
10M11+50 - 225+00		76	123	Acres	88.93
10M11+50 - 225+00		77	123	Acres	88.93
10M11+50 - 225+00		78	123	Acres	88.93
10M11+50 - 225+00		79	123	Acres	88.93
10M11+50 - 225+00		80	123	Acres	88.93
10M11+50 - 225+00		81	123	Acres	88.93
10M11+50 - 225+00		82	123	Acres	88.93
10M11+50 - 225+00		83	123	Acres	88.93
10M11+50 - 225+00		84	123	Acres	88.93
10M11+50 - 225+00		85	123	Acres	88.93
10M11+50 - 225+00		86	123	Acres	88.93
10M11+50 - 225+00		87	123	Acres	88.93
10M11+50 - 225+00		88	123	Acres	88.93
10M11+50 - 225+00		89	123	Acres	88.93
10M11+50 - 225+00		90	123	Acres	88.93
10M11+50 - 225+00		91	123	Acres	88.93
10M11+50 - 225+00		92	123	Acres	88.93
10M11+50 - 225+00		93	123	Acres	88.93
10M11+50 - 225+00		94	123	Acres	88.93
10M11+50 - 225+00		95	123	Acres	88.93
10M11+50 - 225+00		96	123	Acres	88.93
10M11+50 - 225+00		97	123	Acres	88.93
10M11+50 - 225+00		98	123	Acres	88.93
10M11+50 - 225+00		99	123	Acres	88.93
10M11+50 - 225+00		100	123	Acres	88.93

SCHEDULE B

DETAIL SPECIFICATIONS TO ACCOMPANY 1982 PUBLIC WORKS SPECIFICATIONS

ITEM NO.	DESCRIPTION
121	CLEARING AND GRUBBING
121A	Clearing shall extend 10 feet beyond the top of slope in cut and the top of slope in fill. The natural growth shall be retained between the above limits and the R.O.W. except A.D.B.E. The entire interchange area shall be cleared of all growth except trees and shrubs A.D.B.E.
121B	APPLYING WATER
121C	Area: See Schedule A Seed shall be watered as specified under item 124 at the intervals as directed by the Engineer.
121D	TOPSOIL PLACED FROM STOCKPILES
121E	Area: See Schedule A Depth: 3 inches
121F	SEEDING
121G	Area: See Schedule A Seeds: M-58, See Schedule D Type #1: River Overflow areas. Type #1: All other areas.
121H	Fertilizer: M-54 Type No. 1 (1-2-1) M-56, Hay or M-57, Straw Leasing Dates: Type #1: As directed by the Engineer Type #2: Nov between Oct. 1st to Apr. 15th Because of danger of flooding. Method #1 shall apply for all areas except in the milt; all stockpiles 3 inches or over in greatest dimension shall be removed before seeding the milt. Rate of Fertilizer: 80 lbs of Nitrogen per acre Rate of Seed: Type #1: 50 lbs Pure Live Seed Per Acre Type #2: 50 lbs Pure Live Seed Per Acre Rate of Milt: 1 to 1 tons per acre or to completely cover the ground to the satisfaction of the Engineer.
121I	SODDING
121J	Area: See Schedule A Fertilizer shall be as specified above for item 123 Soil: M-52 Type No. 1 Pegging Stakes: M-62 (1" x 2" x 8" min) Topsoil: As specified for item 121 Sodding shall be as shown on signed structure sheet 50 - 34 or as directed by the Engineer. Pegging Sod: Depth of cutting sod shall not be in excess of 1-1/2 inches.
121K	PLANTING
121L	Locations: See Schedule A Plants: See Schedule C (NOTE: Plants shall be rooted cuttings available to the Contractor without charge at Pointed Post, N.Y. Planting material: Topsoil: Not required Fertilizer: Not required Organic Matter: Not required Milt: M-57, 50 lbs Planting seasons: Because of the danger of flooding planting will only be permitted from Apr. 1st to May 15. Size of pits: None required. Seedlings will be stuck in ground using a mattock, crowbar will not be permitted. Staking and planting not required. Milt: To completely cover the ground of the planted beds to the satisfaction of the Engineer. May be applied with Milt #1000) - as part of the sodding operation between the rows.

SCHEDULE C

DETAIL SPECIFICATIONS FOR PLANTS

ITEM NO.	QUANT.	GENUS & SPECIES	ABBR.	COMMON NAME	SIZE	ROOTS	PLANTING	SOURCE	REMARKS	SPACING
121A	121A	Elaeagnus Umbellata		Autumn Olive	2 1/2" dia	cuttings	BR	To be 3 rows staggered 12' x 12'		

SCHEDULE D

DETAIL SPECIFICATIONS FOR SEEDS

ITEM NO.	QUANT.	GENUS & SPECIES	ABBR.	COMMON NAME	SIZE	ROOTS	PLANTING	SOURCE	REMARKS	SPACING
121A	121A	Elaeagnus Umbellata		Autumn Olive	2 1/2" dia	cuttings	BR	To be 3 rows staggered 12' x 12'		

SUMMARY

ITEM	TOTAL QUANTITY	NAME OF ITEM
121A	24,905 S.F.	Applying Water
121B	180 Acres	Topsoil Placed From Stockpiles
121C	180 Acres	Seeding
121D	180 Acres	Seeding
121E	180 Acres	Seeding
121F	180 Acres	Seeding
121G	180 Acres	Seeding
121H	180 Acres	Seeding
121I	180 Acres	Seeding
121J	180 Acres	Seeding
121K	180 Acres	Seeding
121L	180 Acres	Seeding
121M	180 Acres	Seeding
121N	180 Acres	Seeding
121O	180 Acres	Seeding
121P	180 Acres	Seeding
121Q	180 Acres	Seeding
121R	180 Acres	Seeding
121S	180 Acres	Seeding
121T	180 Acres	Seeding
121U	180 Acres	Seeding
121V	180 Acres	Seeding
121W	180 Acres	Seeding
121X	180 Acres	Seeding
121Y	180 Acres	Seeding
121Z	180 Acres	Seeding

REVISIONS

1. SCHEDULE A
2. SCHEDULE D SUMMARY

Key To ABBREVIATIONS:
BR - Bare Root

ROADSIDE DEVELOPMENT SHEET

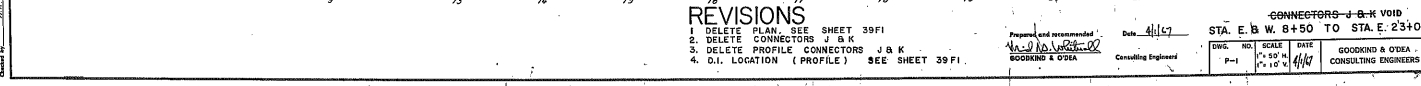
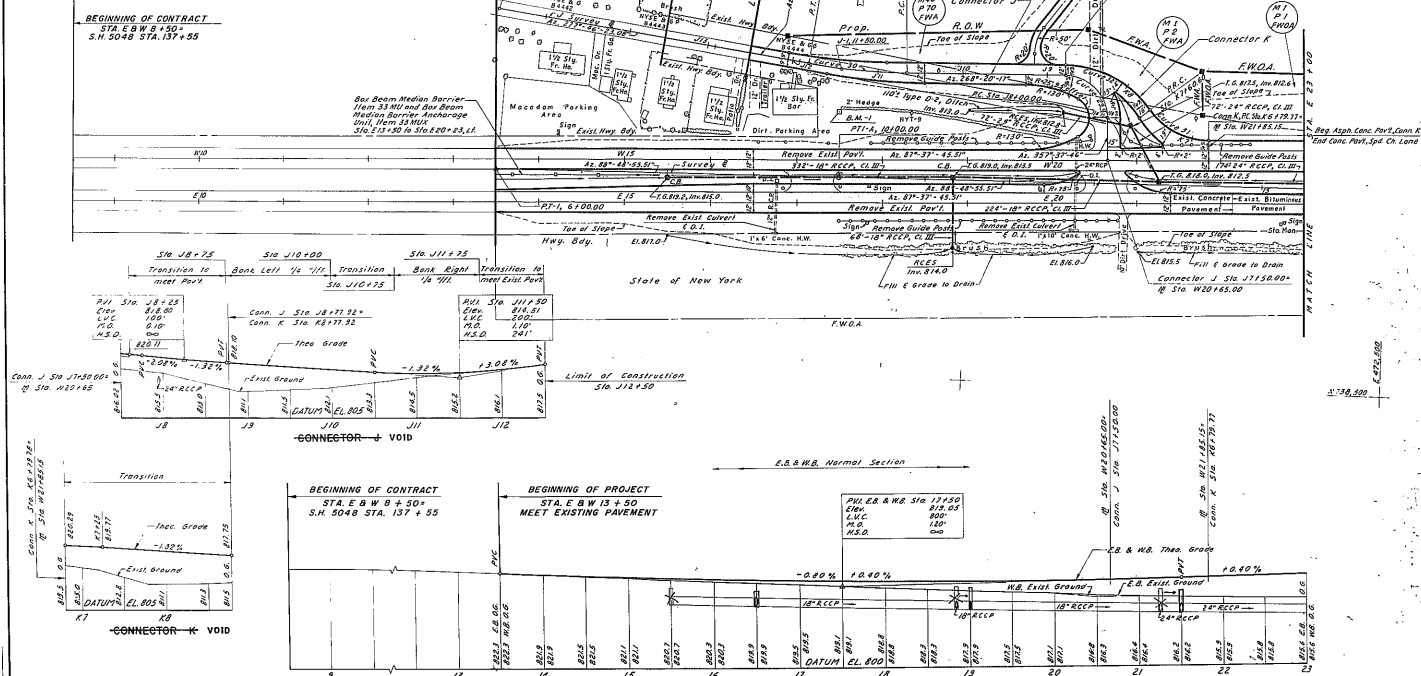
E. J. ...
APPROVED DESIGN LANDSCAPE ARCHITECT

DATE: 4/1/79

DWG NO. RD1
SCALE: N=1"=40'
DATE: 4/1/79
GOODKIND & O'DEA CONSULTING ENGINEERS

SOUTHERN TIER EXPRESSWAY SECTION 6R
LOWMAN - WAVERLY PART 1
CHEMUNG COUNTY

CURVE DATA						COORDINATES					
No.	R	Δ	D	T	L	N	E	N	E	N	E
29	50.000	137°21'29"	104°51'28.60"	49.388	77.927	738812.111	476,108.882	738812.111	473,409.218		
30	700.000	8°26'00.00"	8°41'00.00"	57.768	115.227	738855.822	473,281.160	738855.822	471,406.583		
31	85.000	144°20'00.00"	67°24'24.84"	43.782	80.888	738791.400	473,282.160	738812.111	473,214.205		
32	125.000	134°44'28.83"	45°20'12.84"	63.382	117.319	738825.132	473,211.588	738825.132	472,103.210		



REVISIONS

1. DELETE PLAN, SEE SHEET 39F1
2. DELETE CONNECTORS J & K
3. DELETE PROFILE CONNECTORS J & K
4. D.I. LOCATION (PROFILE) SEE SHEET 39F1.

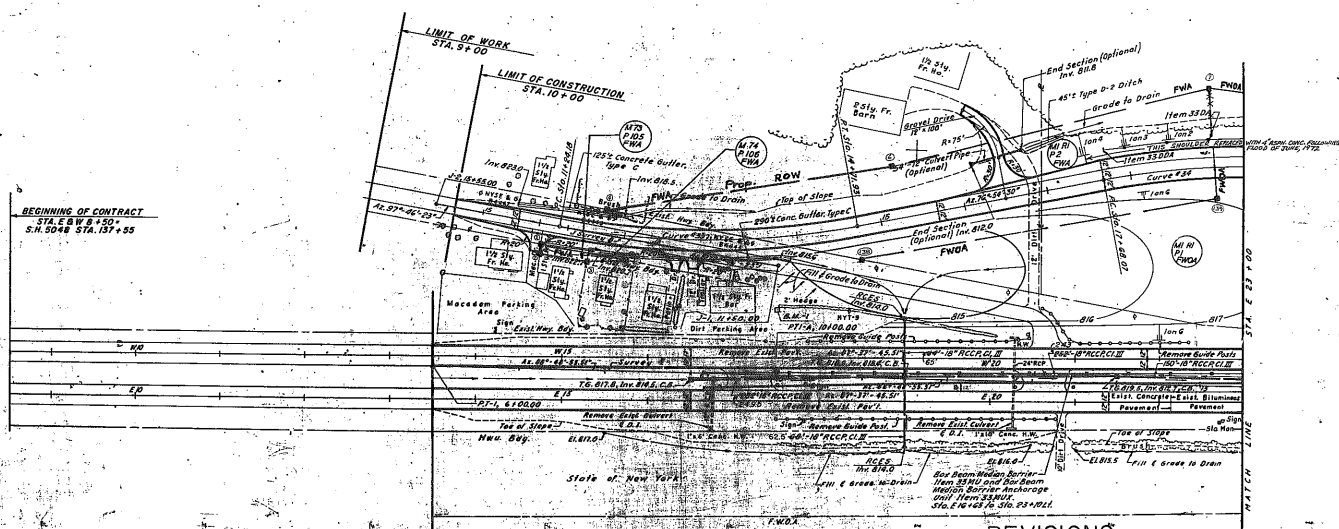
Prepared and recommended by: *[Signature]* Date: 4/1/77
 Consulting Engineer: GOODRIND & O'NEA
 STA. E & W 8 + 50 TO STA. E 23 + 00
 Scale: 1" = 40' HORIZ. 1" = 10' VERT.
 SHEET NO. P-1 DATE 4/1/77 CONSULTING ENGINEERS

CURVE DATA						COORDINATES					
No.	R	Δ	D	T	L	N	E	N	E		
38	387.800	10°-01'-53"	6°-00'-00"	10175.820'	567.742'	258.021	723	121.568	072	228.201	600
39	228.201	104°-53'-30"	6°-00'-00"	1245.038	475.072'	258.021	682	120.222	371	228.201	600

FED. ROAD REG. NO.	STATE	FED. AID PROJ. NO.	FISCAL YEAR	SHEET NO.	TOTAL SHEETS
1	N.Y.			39	109

SOUTHERN TIER EXPRESSWAY SECTION 6R
 LOWMAN - WAVERLY PART 1
 CHEMUNG COUNTY

FIELD CHANGE



REVISIONS

1. R.O.W. MONUMENTS NUMERATION
 2. REVISION TO PIPE LENGTHS
 3. GUIDE RAIL (SEE SHEET 28R1)
- NOTE: THIS SHEET REVISED TO SHOW WORK DONE FOLLOWING EMBANKMENT OF JUNE, 1972. EMERGENCY REPAIR CONTRACTOR'S SHEET DELETES PLANNED CONNECTIONS BETWEEN THE EXPRESSWAY AND THE COUNTY ROAD AND REALIGNS THE COUNTY ROAD.

APPROVED
 [Signature]
 [Title]

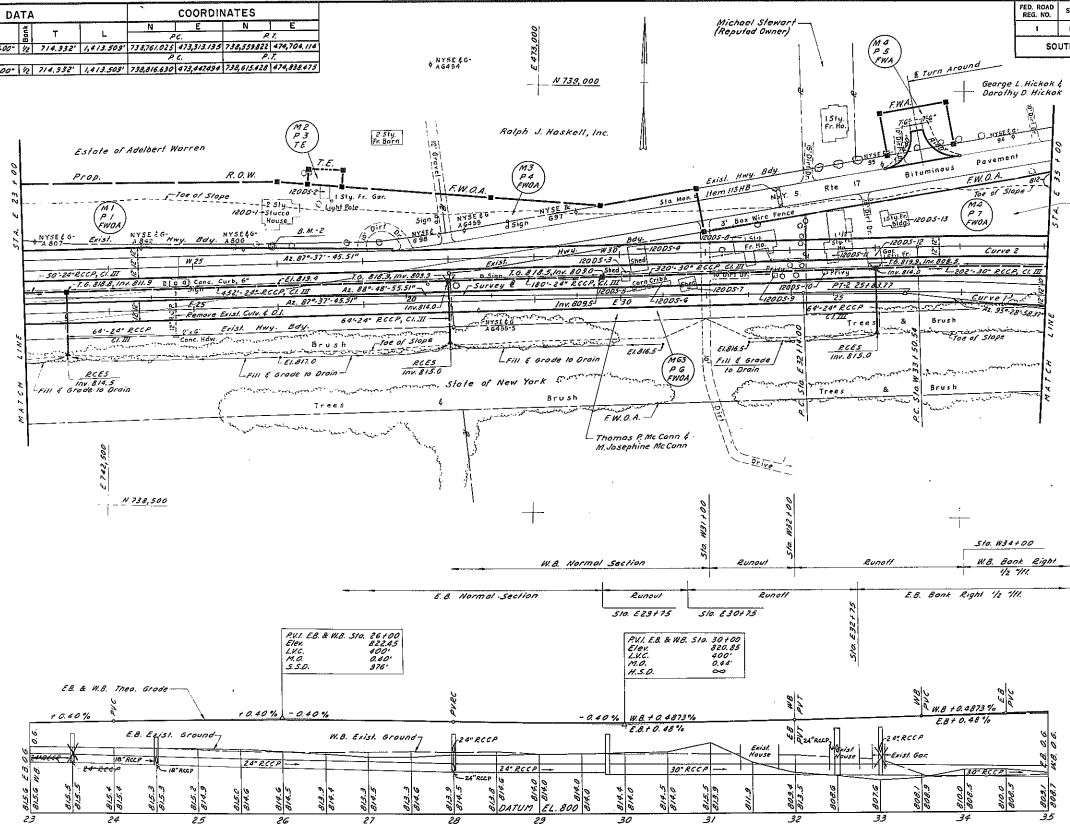
Proposed and Recommended
 [Signature]
 [Title]

STA. E. & W. 8+50 TO STA. E. 23+00
 [Signature]
 [Title]

CURVE DATA						COORDINATES					
No.	R	Δ	D	T	L	N	E	N	E	N	E
1	3,813.719	27°12'03.43"	27°12'03.43"	714.332	1,413.209	728,816.630	423,842.854	728,816.630	423,842.854	728,816.630	423,842.854
2	3,813.719	27°12'03.43"	27°12'03.43"	714.332	1,413.209	728,816.630	423,842.854	728,816.630	423,842.854	728,816.630	423,842.854

FED. ROAD REG. NO.	STATE	FED. AID PROJ. NO.	FISCAL YEAR	SHEET NO.	TOTAL SHEETS
1	N.Y.			40 R1	190

SOUTHERN TIER EXPRESSWAY SECTION 6R
 LOWMAN - WAVERLY PART 1
 CHEMUNG COUNTY



PULL E.B. & W.B. STA. 26+00	500.00
L.V.C.	400.00
M.G.	600.00
S.C.A.	900.00

PULL E.B. & W.B. STA. 30+00	500.00
L.V.C.	400.00
M.G.	600.00
H.S.P.	00

- REVISIONS**
1. DELETE PLAN (SEE SHEET 40 F1)
 2. D.I. LOCATION & PIPE DIAMETERS, (PROFILE)

Proposed and recommended
 GOODING & O'DEA
 Consulting Engineers

STA. E. 23+00 TO STA. E. 35+00

DWG. NO.	SCALE	DATE	GOODING & O'DEA CONSULTING ENGINEERS
P-2	1" = 50' H	4/1/67	

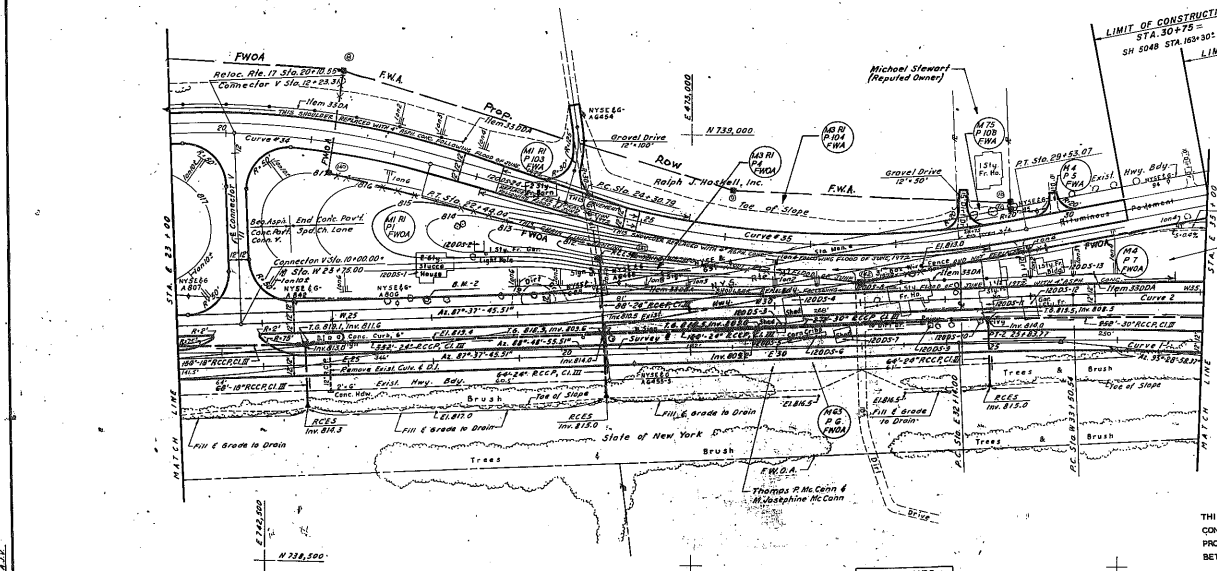
All Changes Made by: [Signature]
 Checked by: [Signature]
 Date: [Date]

FED. ROAD DIST. NO.	STATE	FISCAL YEAR	SHEET NO.	TOTAL SHEETS
1	N.Y.		40	119

SOUTHERN TIER EXPRESSWAY SECTION 6R
 LOWMAN - WAVERLY PART 1
 CHEMUNG COUNTY

FIELD CHANGE

CURVE DATA				COORDINATES			
No	R	Δ	D	N	E	N	E
1	2,670.773	27°-11'00"	17-30-00"	716.332	4712.892	728.161	4721.133
2	1,872.721	27°-11'00"	17-30-00"	316.332	4412.892	328.161	4421.133
3	356.350	28°-11'-30"	6°-00'-00"	248.034	472.377	258.948	472.377
4	1,145.876	26°-00'-50"	5°-20'-00"	265.724	202.200	276.125	202.200



- REVISIONS**
1. R.O.W. MONUMENTS NUMERATION
 2. LENGTH OF PIPES
 3. GUIDE RAIL (SEE SHEET 28R1)
- NOTE: SHOULDER & PAVEMENT REPLACEMENT FOLLOWING ROAD OF STATE 1972. RESS EXISTING LINE PAVING MAINTAINED AND NOT REPLACED AS SHOWN. THIS WORK DONE UNDER CONTRACT WITH CHEMUNG COUNTY. P.N. 6700.95.92.

THIS SHEET REALIGNS OLD ROUTE 17 AND CONNECTS IT TO THE COUNTY ROAD. IT ALSO PROVIDES A SINGLE CONNECTION CONNECTOR 'V' BETWEEN THE COUNTY ROAD AND THE EXPRESSWAY.

APPROVED
 [Signature]
 Civil Engineer

Prepared and recommended by: [Signature]
 GOODKIND & O'DEA
 Consulting Engineers

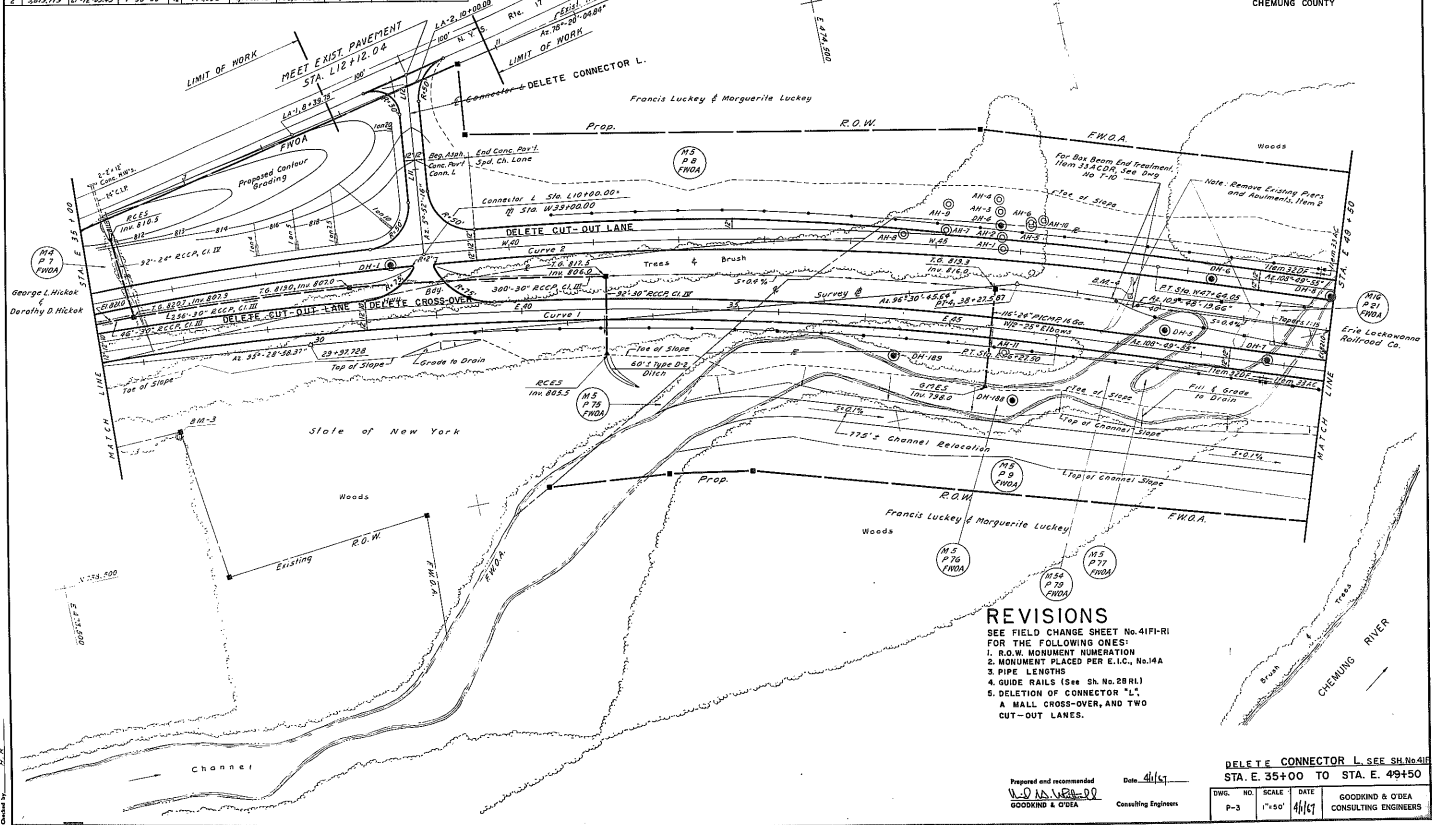
STA. E. 23+00 TO STA. E. 35+00	DATE	SCALE
	11/19	1" = 50'

Checked by: [Signature]
 Date: 11/19/72
 Title: [Signature]
 Title: [Signature]

CURVE DATA						COORDINATES					
No.	R	Δ	D	T	L	N	E	N	E	N	E
1	3818.51'	27°12'08.45"	7°30'00"	214832'	6118.89'	738761.025	725121.13	732558.82	727204.174		
2	2818.51'	27°12'08.45"	7°30'00"	214832'	6118.89'	738761.025	725121.13	732558.82	727204.174		

FED. ROAD REG. NO.	STATE	FED. AID PROJ. NO.	FISCAL YEAR	SHEET NO.	TOTAL SHEETS
1	N.Y.			41/41	199

SOUTHERN TIER EXPRESSWAY SECTION 6R
LOWMAN - WAVERLY PART 1
CHEMUNG COUNTY



- REVISIONS**
SEE FIELD CHANGE SHEET No. 41FR-1 FOR THE FOLLOWING ONES:
1. R.O.W. MONUMENT NUMERATION
 2. MONUMENT PLACED PER E.I.C., No. 14A
 3. PIPE LENGTHS
 4. GUIDE RAILS (See Sh. No. 28 RL)
 5. DELETION OF CONNECTOR "L"
- A. HALL CROSS-OVER, AND TWO CUT-OUT LANES.

Prepared and recommended by: **V. O. McVee, P.E.**
GOODKIND & O'DEA Consulting Engineers

Date: **4/1/50**

DWG. NO.	SCALE	DATE	GOODKIND & O'DEA CONSULTING ENGINEERS
P-3	1"=50'	4/1/50	

In Charge of...
 Checked by...
 Drawn by...

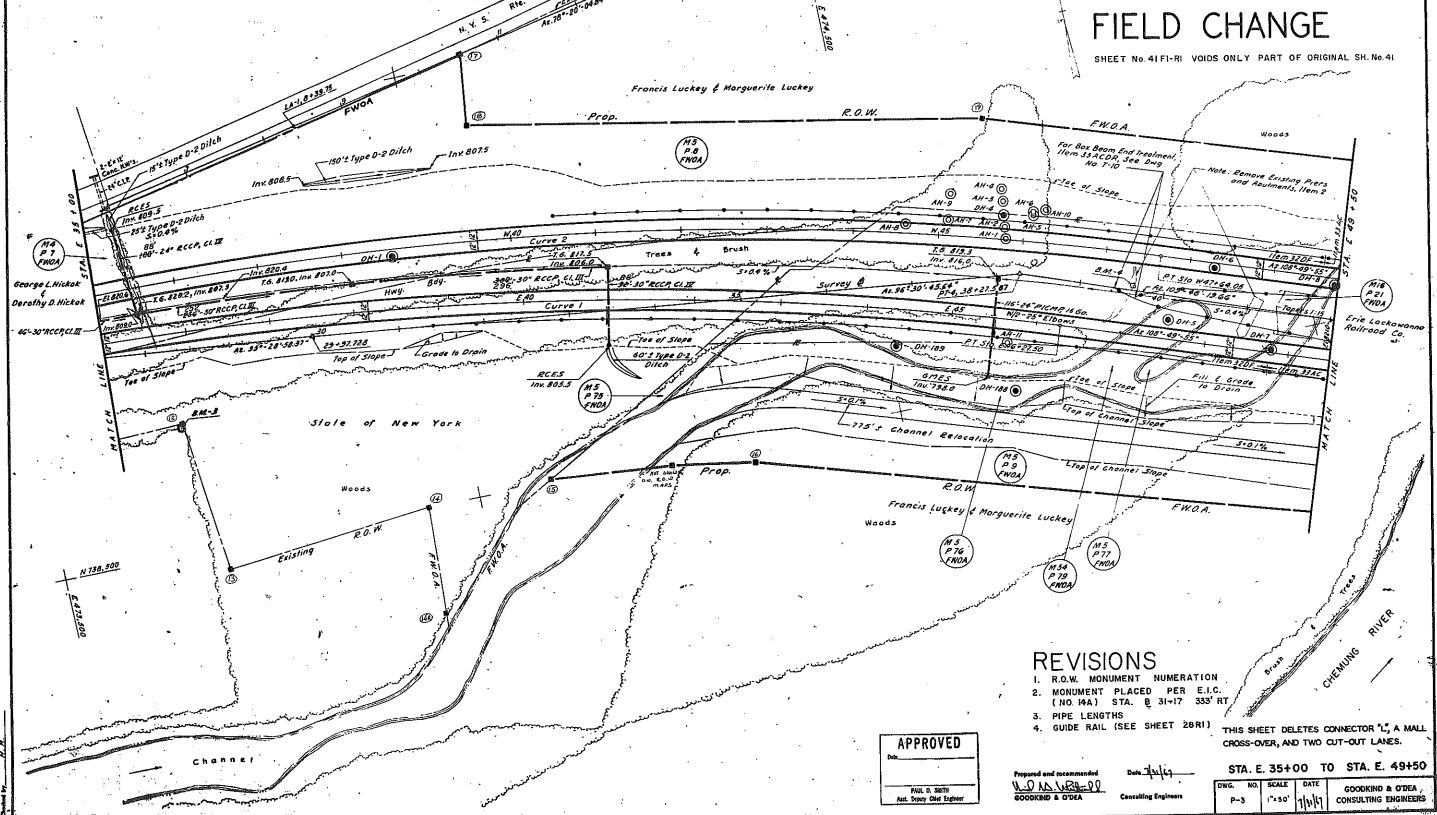
FED. ROAD DIST. NO.	STATE	FED. AID PROJ. NO.	FISCAL YEAR	SHEET NO.	TOTAL SHEETS
1	N.Y.			4/FIR	199

SOUTHERN TIER EXPRESSWAY SECTION 6R
 LOWMAN - WAVERLY PART 1
 CHEMUNG COUNTY

FIELD CHANGE

SHEET No. 41 FI-RI VOIDS ONLY PART OF ORIGINAL SH. No. 41

CURVE DATA					COORDINATES					
No.	R.	Δ	D	L	N	E	N	E	X	Y
1	28137.2	12°-14'08.42"	17-30.26'	271	714332	4812893	228261023	228261023	228261023	228261023
2	180137.2	12°-14'08.42"	17-30.26'	271	714332	4812893	228261023	228261023	228261023	228261023



REVISIONS

- R.O.W. MONUMENT NUMERATION
- MONUMENT PLACED PER E.I.C. (NO. 14A) STA. @ 31+17 335' RT
- PIPE LENGTHS
- GUIDE RAIL (SEE SHEET 28R1)

THIS SHEET DELETES CONNECTOR "A", A SMALL CROSS-OVER, AND TWO CUT-OUT LANES.

APPROVED
 Date: _____
 HUI S. BATH
 Asst. State Chief Engineer

Prepared and accompanied by: W.D. WEAVER
 GOODKIND & O'DEA
 Consulting Engineers

STA. E. 35+00 TO STA. E. 49+50
 DWG. NO. P-3 SCALE 1"=50' DATE 7/1/19
 GOODKIND & O'DEA
 CONSULTING ENGINEERS

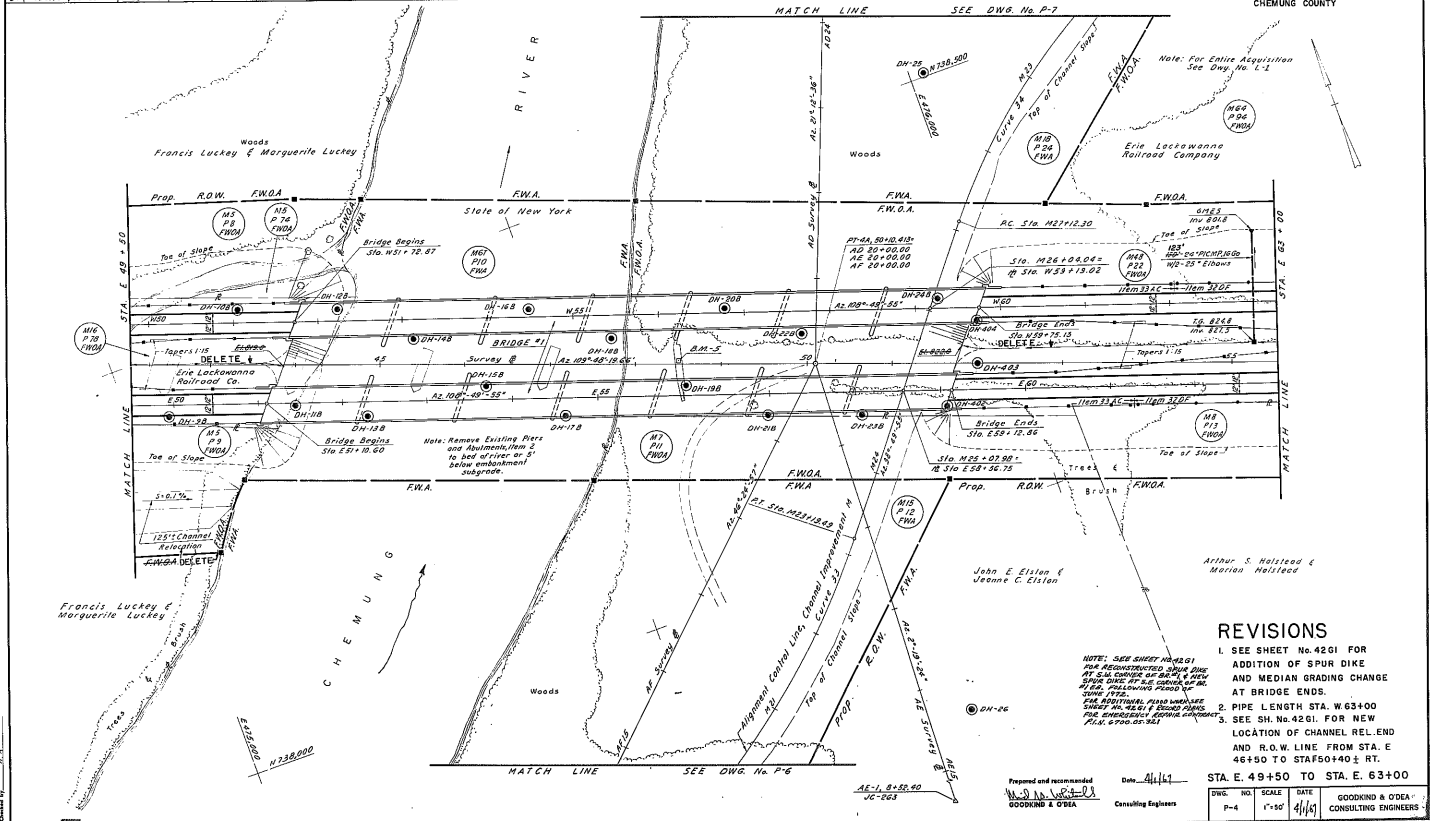
As Shown on: 1. 11/1/19
 2. 11/1/19
 3. 11/1/19
 4. 11/1/19
 5. 11/1/19
 6. 11/1/19
 7. 11/1/19
 8. 11/1/19
 9. 11/1/19
 10. 11/1/19
 11. 11/1/19
 12. 11/1/19
 13. 11/1/19
 14. 11/1/19
 15. 11/1/19
 16. 11/1/19
 17. 11/1/19
 18. 11/1/19
 19. 11/1/19
 20. 11/1/19
 21. 11/1/19
 22. 11/1/19
 23. 11/1/19
 24. 11/1/19
 25. 11/1/19
 26. 11/1/19
 27. 11/1/19
 28. 11/1/19
 29. 11/1/19
 30. 11/1/19
 31. 11/1/19
 32. 11/1/19
 33. 11/1/19
 34. 11/1/19
 35. 11/1/19
 36. 11/1/19
 37. 11/1/19
 38. 11/1/19
 39. 11/1/19
 40. 11/1/19
 41. 11/1/19
 42. 11/1/19
 43. 11/1/19
 44. 11/1/19
 45. 11/1/19
 46. 11/1/19
 47. 11/1/19
 48. 11/1/19
 49. 11/1/19
 50. 11/1/19
 51. 11/1/19
 52. 11/1/19
 53. 11/1/19
 54. 11/1/19
 55. 11/1/19
 56. 11/1/19
 57. 11/1/19
 58. 11/1/19
 59. 11/1/19
 60. 11/1/19
 61. 11/1/19
 62. 11/1/19
 63. 11/1/19
 64. 11/1/19
 65. 11/1/19
 66. 11/1/19
 67. 11/1/19
 68. 11/1/19
 69. 11/1/19
 70. 11/1/19
 71. 11/1/19
 72. 11/1/19
 73. 11/1/19
 74. 11/1/19
 75. 11/1/19
 76. 11/1/19
 77. 11/1/19
 78. 11/1/19
 79. 11/1/19
 80. 11/1/19
 81. 11/1/19
 82. 11/1/19
 83. 11/1/19
 84. 11/1/19
 85. 11/1/19
 86. 11/1/19
 87. 11/1/19
 88. 11/1/19
 89. 11/1/19
 90. 11/1/19
 91. 11/1/19
 92. 11/1/19
 93. 11/1/19
 94. 11/1/19
 95. 11/1/19
 96. 11/1/19
 97. 11/1/19
 98. 11/1/19
 99. 11/1/19
 100. 11/1/19

CURVE DATA						COORDINATES					
No.	R	Δ	D	T	L	N	E	N	E		
33	1,000.00	27°43'00"	27°43'00"	284.074	883.361	73,370,613	47,510,272	73,860,036	47,533,184		
34	750.00	60°35'00"	27°30'21.8"	438.118	793.021	73,826,340	48,333,690	73,826,340	47,620,433		

FED. ROAD REG. NO.	STATE	FED. AID PROJ. NO.	FISCAL YEAR	SHEET NO.	TOTAL SHEETS
1	N.Y.			42 of 119	199

SOUTHERN TIER EXPRESSWAY SECTION 6R

LOWMAN - WAVERLY PART 1
CHEMUNG COUNTY



- ### REVISIONS
- SEE SHEET No. 42GI FOR ADDITION OF SPUR DIKE AND MEDIAN GRADING CHANGE AT BRIDGE ENDS.
 - PIPE LENGTH STA. W 63+00
 - SEE SH. No. 42GI FOR NEW LOCATION OF CHANNEL REL. END AND R.O.W. LINE FROM STA. E 46+50 TO STA. E. 63+00

NOTE: SEE SHEET No. 42GI FOR REVISIONS TO THIS DRAWING. ALL DIMENSIONS ARE TO FACE UNLESS OTHERWISE NOTED. THE FOLLOWING POINTS OF INTEREST ARE: STA. 46+50 TO STA. 47+00. STA. 63+00 TO STA. 63+50.

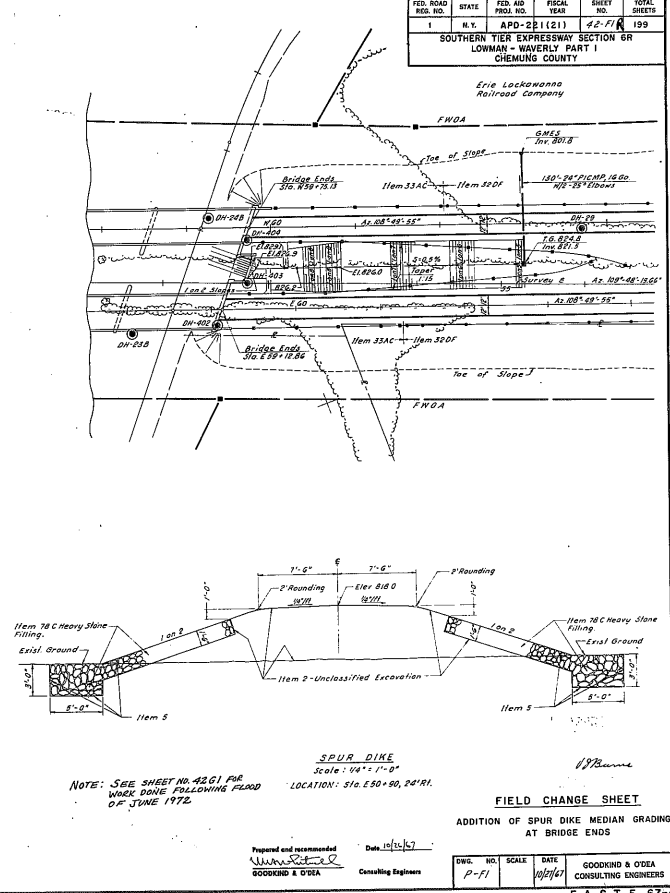
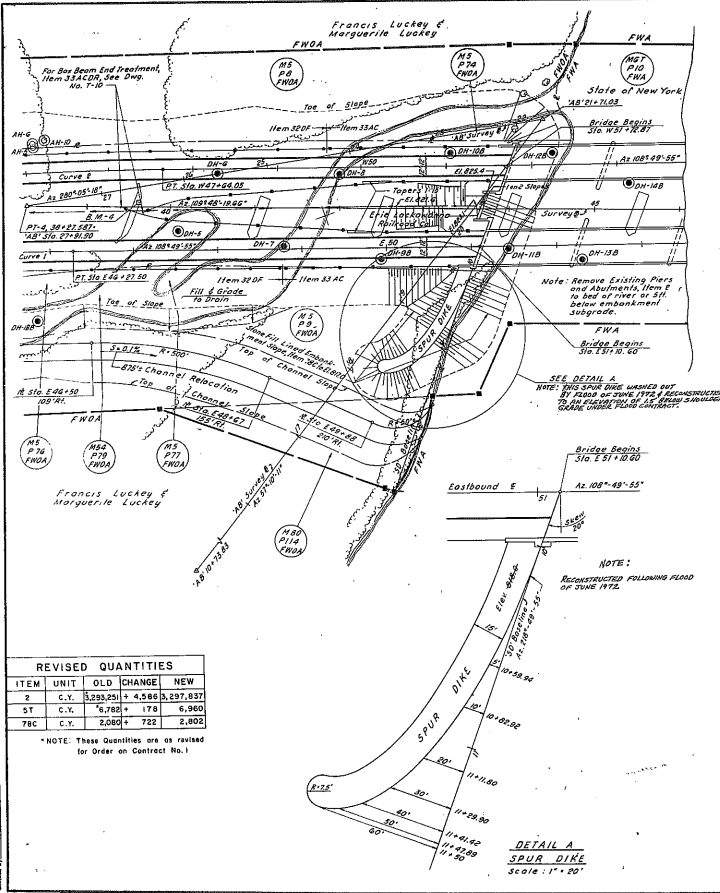
Prepared and recommended by: *[Signature]*
Consulting Engineers

DWG. NO.	SCALE	DATE	DATE
P-4	1"=50'	4/1/19	

GOODING & O'DEA
CONSULTING ENGINEERS

FED. ROAD PROJ. NO.	STATE	FED. AID PROJ. NO.	FISCAL YEAR	SHEET NO.	TOTAL SHEETS
1	N.Y.	APD-211(21)	1957	22-77	199

SOUTHERN TIER EXPRESSWAY SECTION OR LOWMAN - WAVERLY PART I CHEMUNG COUNTY



REVISED QUANTITIES

ITEM	UNIT	OLD	CHANGE	NEW
2	C.Y.	3,293.75	+ 4,286	3,297.637
51	C.Y.	5,700	- 170	5,500
78C	C.Y.	2,080	+ 722	2,802

* NOTE: These Quantities are as revised for Order on Contract No. 1.

NOTE: SEE SHEET NO. 42 G1 FOR WORK DONE FOLLOWING FLOOD OF JUNE 1972. LOCATION: STA. 50+90, 24°11'

FIELD CHANGE SHEET
ADDITION OF SPUR DIKE MEDIAN GRADING AT BRIDGE ENDS

Prepared and recommended by: *[Signature]* Date: 10/25/67
GOODKIND & O'DEA Consulting Engineers

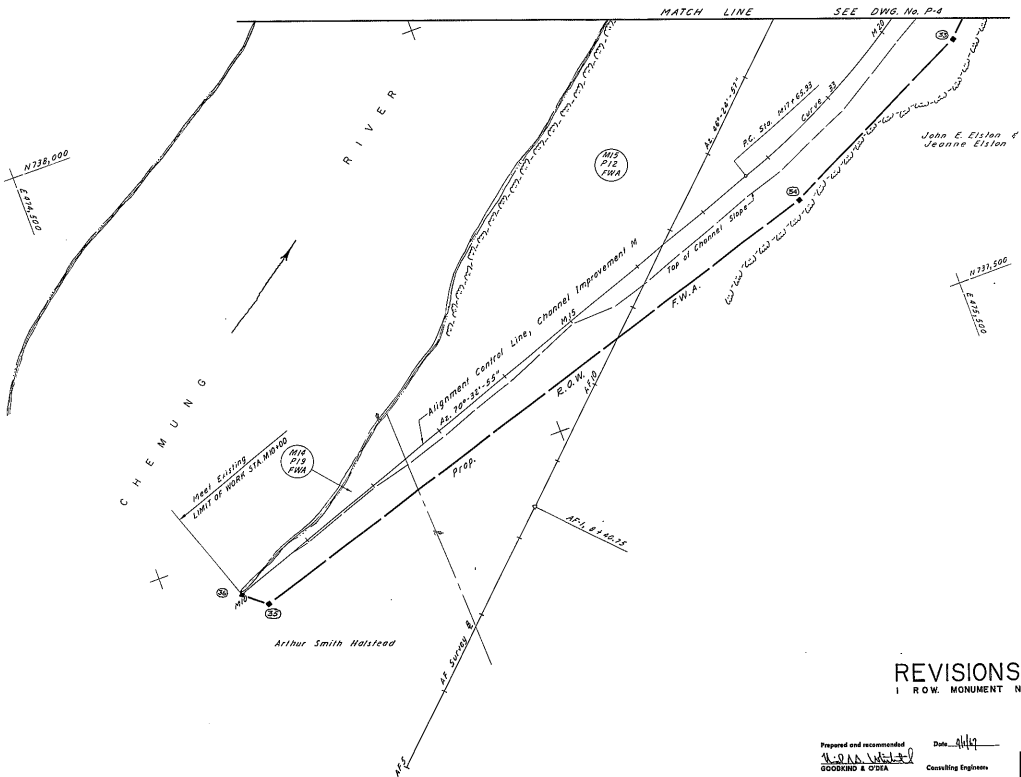
DWG. NO.	SCALE	DATE	GOODKIND & O'DEA CONSULTING ENGINEERS
P-1		10/25/67	

CURVE DATA						COORDINATES					
No.	R	Δ	D	T	L	N	E	N	E		
						PC	PT	PC	PT		
33	100000	37°-43'-00"	54°-43'-46.42"	284.072	553.361	73,170.019	913,102.21	736,020.144	675,251.197		

FED. ROAD REG. NO.	STATE	FED. AID PROJ. NO.	FISCAL YEAR	SHEET NO.	TOTAL SHEETS
1	N.Y.			42 RI	199

SOUTHERN TIER EXPRESSWAY SECTION 6R

LOWMAN - WAVERLY PART 1
CHEMUNG COUNTY



REVISIONS
1 R.O.W. MONUMENT NUMERATION

Prepared and recommended
[Signature]
GOODKIND & O'DEA
Consulting Engineers

Date: 4/1/17

CHANNEL IMPROVEMENT M

DWG. NO.	SCALE	DATE	GOODKIND & O'DEA CONSULTING ENGINEERS
P-6	1"=50'	4/1/17	

In Charge: *[Signature]*
 Checked by: *[Signature]*
 Date: 4/1/17

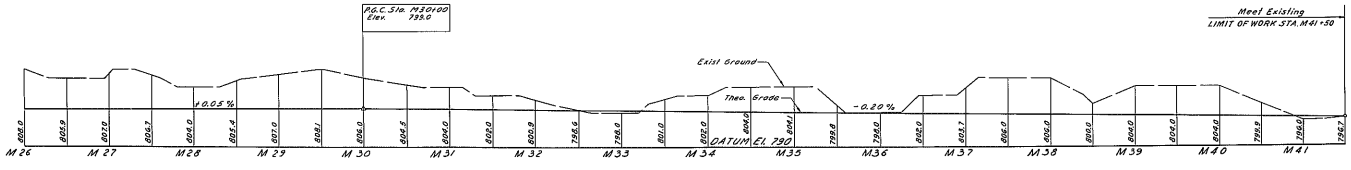
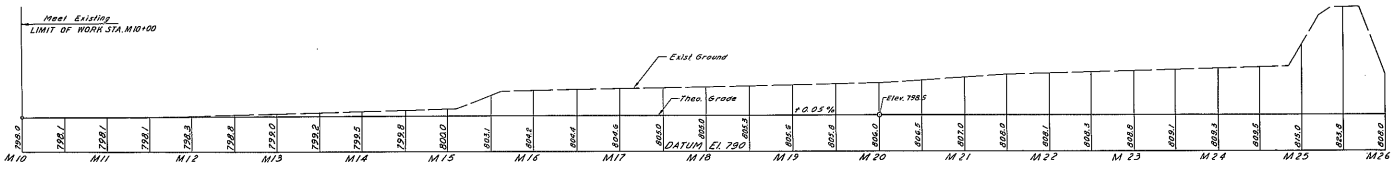


PLATE 07-4

FED. ROAD DIST. NO.	STATE	FED. AID PROJ. NO.	FISCAL YEAR	SHEET NO.	TOTAL SHEETS
1	N.Y.	APD 221-013	66	26	200

SOUTHERN TIER EXPRESSWAY SECTION 6R

LOWMAN - WAVERLY PART 1
CHEMUNG COUNTY



Checked by: [Signature]
 Date: [Date]

Prepared and recommended by: [Signature]
 GOODKIND & O'DEA
 Consulting Engineers

Date: 4/1/67

CHANNEL IMPROVEMENT M

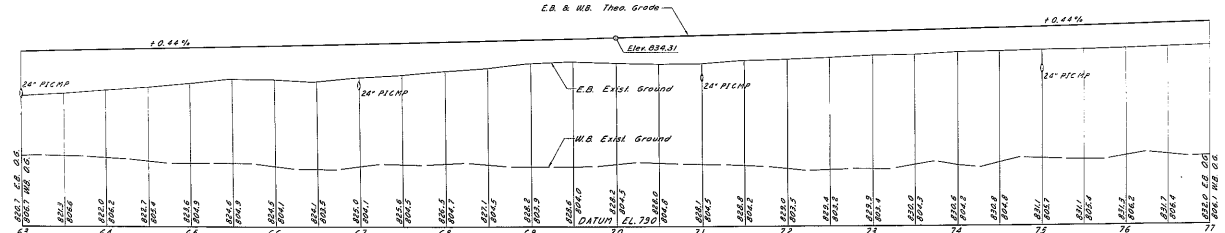
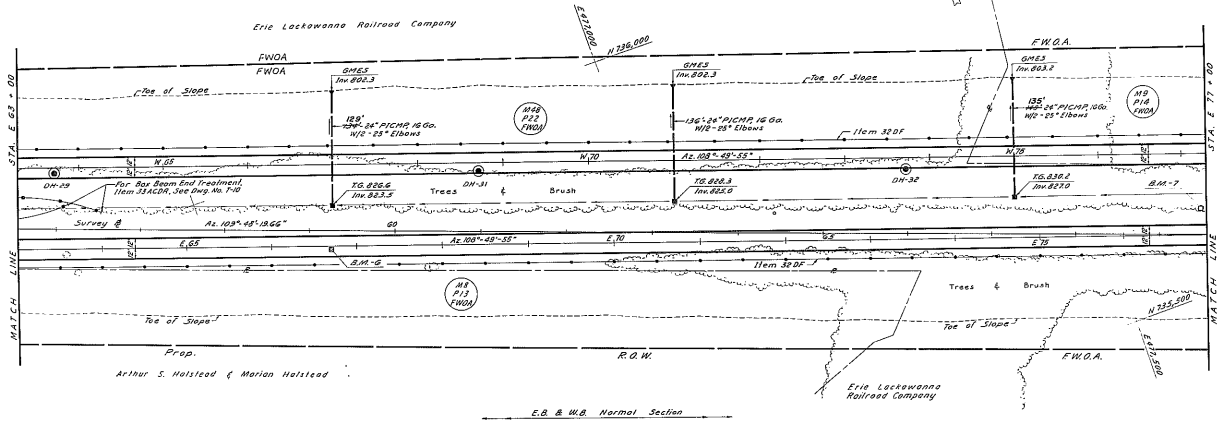
DWG. NO.	SCALE	DATE	GOODKIND & O'DEA CONSULTING ENGINEERS
P-8	1" = 50' H 1" = 100' V	4/1/67	

FED. ROAD DIST. NO.	STATE	FED. AID PROJ. NO.	FISCAL YEAR	SHEET NO.	TOTAL SHEETS
1	N.Y.			47 RI	199

SOUTHERN TIER EXPRESSWAY SECTION 6R

LOWMAN - WAVERLY PART I
CHEMUNG COUNTY

Note: For Entire Acquisition,
See Drawg. Nos. L-1 & L-2



REVISIONS
1. PIPE LENGTHS, STA.
W.67+00 & STA. W75+00

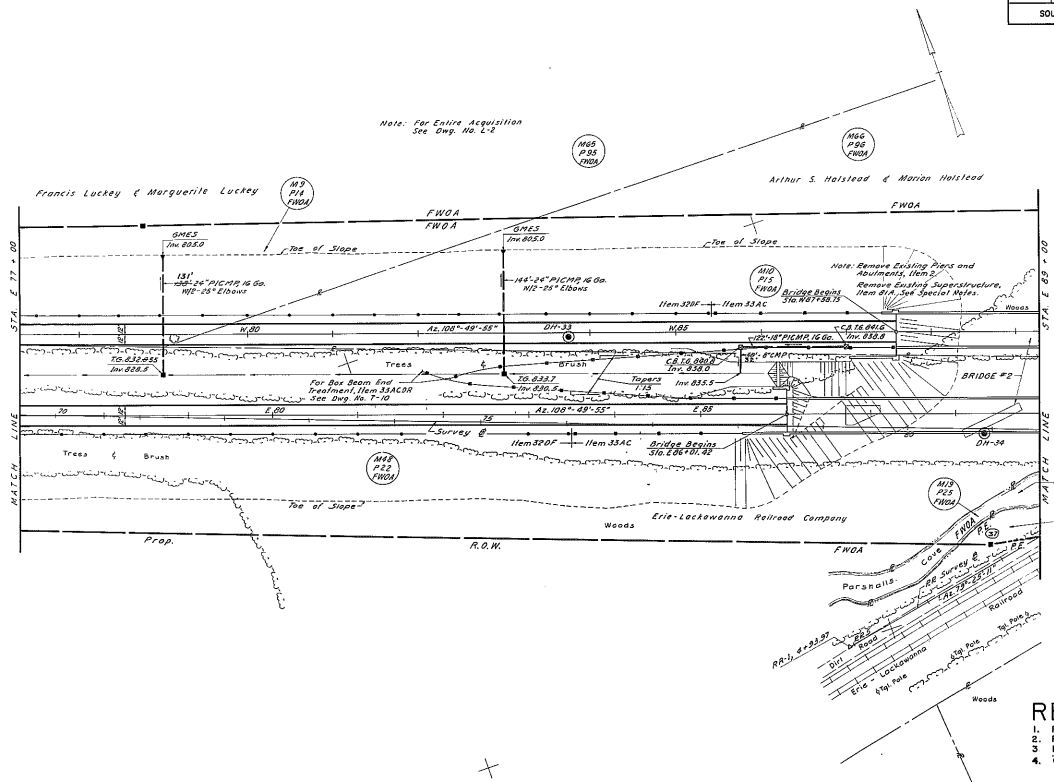
Prepared and recommended by
[Signature]
GOODENO & O'DEA
Consulting Engineers

STA. E. 63+00 TO STA. E. 77+00
DWR. NO. P-9
SCALE 1" = 50' H
DATE 11/11
GOODENO & O'DEA
CONSULTING ENGINEERS

In Charge: *[Signature]*
 Made by: *[Signature]*
 Checked by: *[Signature]*

FED. ROAD DIST. NO.	STATE	FED. AID PROJ. NO.	FISCAL YEAR	SHEET NO.	TOTAL SHEETS
1	N.Y.			28 RI	199

SOUTHERN TIER EXPRESSWAY SECTION 6R
LOWMAN - WAVERLY PART 1
CHEMUNG COUNTY



- REVISIONS**
1. R.O.W. MONUMENT NUMERATIONS
 2. PIPE LENGTHS, STA. W79+00 & W85+75 RT
 3. D.I. STA. W79+00 ELEVATIONS
 4. GUIDE RAIL (SEE SHEET 28 RI)

Prepared and recommended
10/11/83
 GOODKIND & ODEA
 Consulting Engineers

Date: 4/1/87
 STA. E. 77+00 TO STA. E. 89+00
 DWG. NO. SCALE DATE
 P-10 1"=50' 4/1/87
 GOODKIND & ODEA
 CONSULTING ENGINEERS

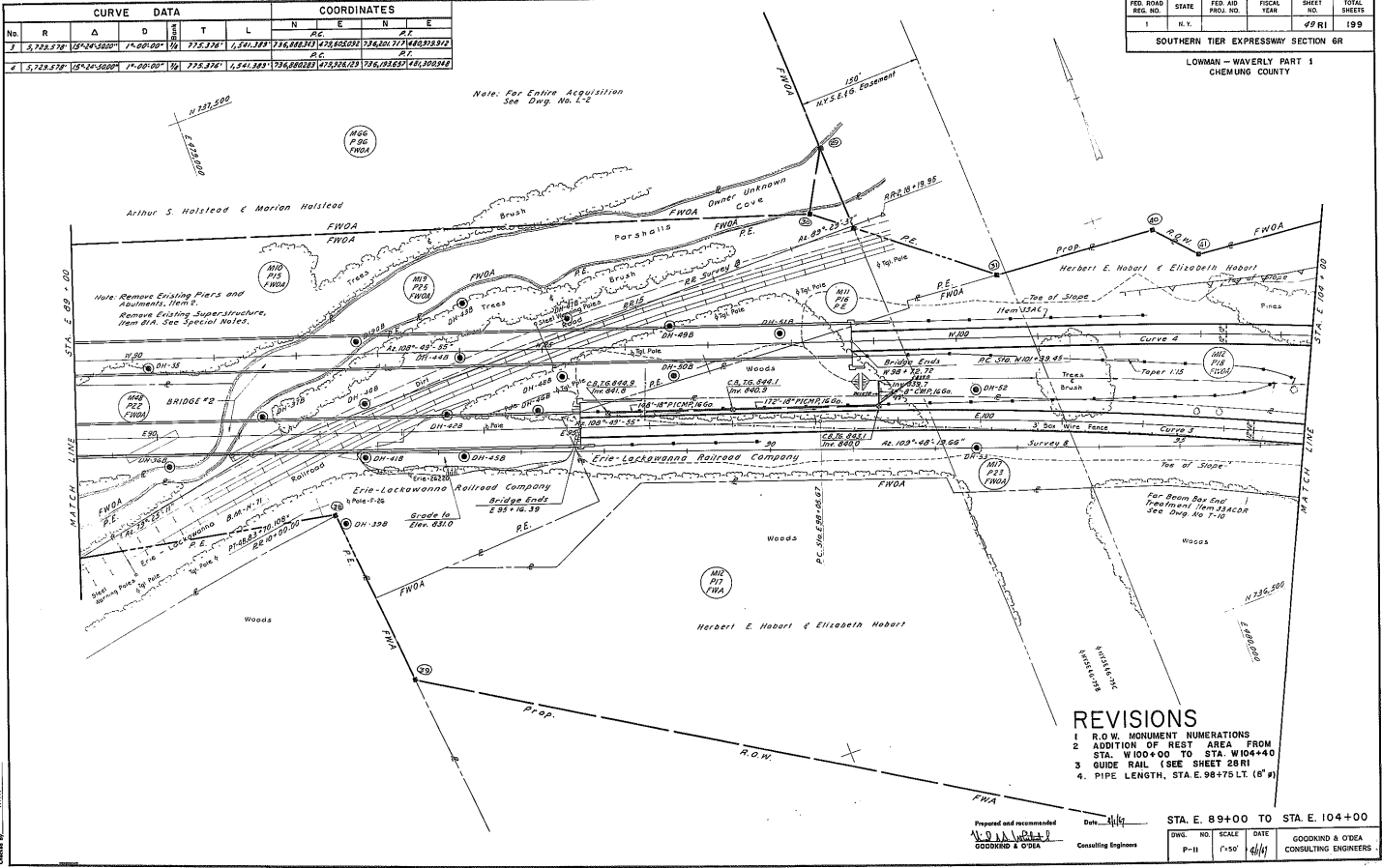
In Charge: 10/11/83
 Checked by: 10/11/83
 Approved by: 10/11/83
 Date: 10/11/83

CURVE DATA						COORDINATES					
No.	R	A	D	T	L	N	E	N	E		
1	3,728.574	15°24'50.00"	17.00'00"	171	772.374	1,561.181	736.816	478.850	736.816	478.850	736.816
2	5,229.872	12°24'50.00"	17.00'00"	171	772.374	1,561.181	736.816	478.850	736.816	478.850	736.816

FED. ROAD DIST. NO.	STATE	FED. AID PROJ. NO.	FISCAL YEAR	SHEET NO.	TOTAL SHEETS
1	N.Y.			4281	199

SOUTHERN TIER EXPRESSWAY SECTION 6R
LOWMAN - WAVELY PART 1
CHEMUNG COUNTY

Note: For Entire Acquisition See Dwg. No. E-2



REVISIONS

1. R.O.W. MONUMENT NUMERATIONS
2. ADDITION OF REST AREA FROM STA. W104+00 TO STA. W104+40
3. GUIDE RAIL (SEE SHEET 28R1)
4. PIPE LENGTH, STA. E. 98+75 LT. (6' 9")

Prepared and recommended by **W. J. WOODS**
 Consulting Engineers
 Date: **4/1/41**
 STA. E. 89+00 TO STA. E. 104+00
 SHEET NO. **P-11** SCALE **1"=50'** DATE **4/1/41** GOODING & ODEA CONSULTING ENGINEERS

W. J. Woods
 Consulting Engineer
 100 N. 1st St.
 Erie, Pa.
 4/1/41

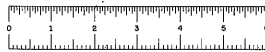
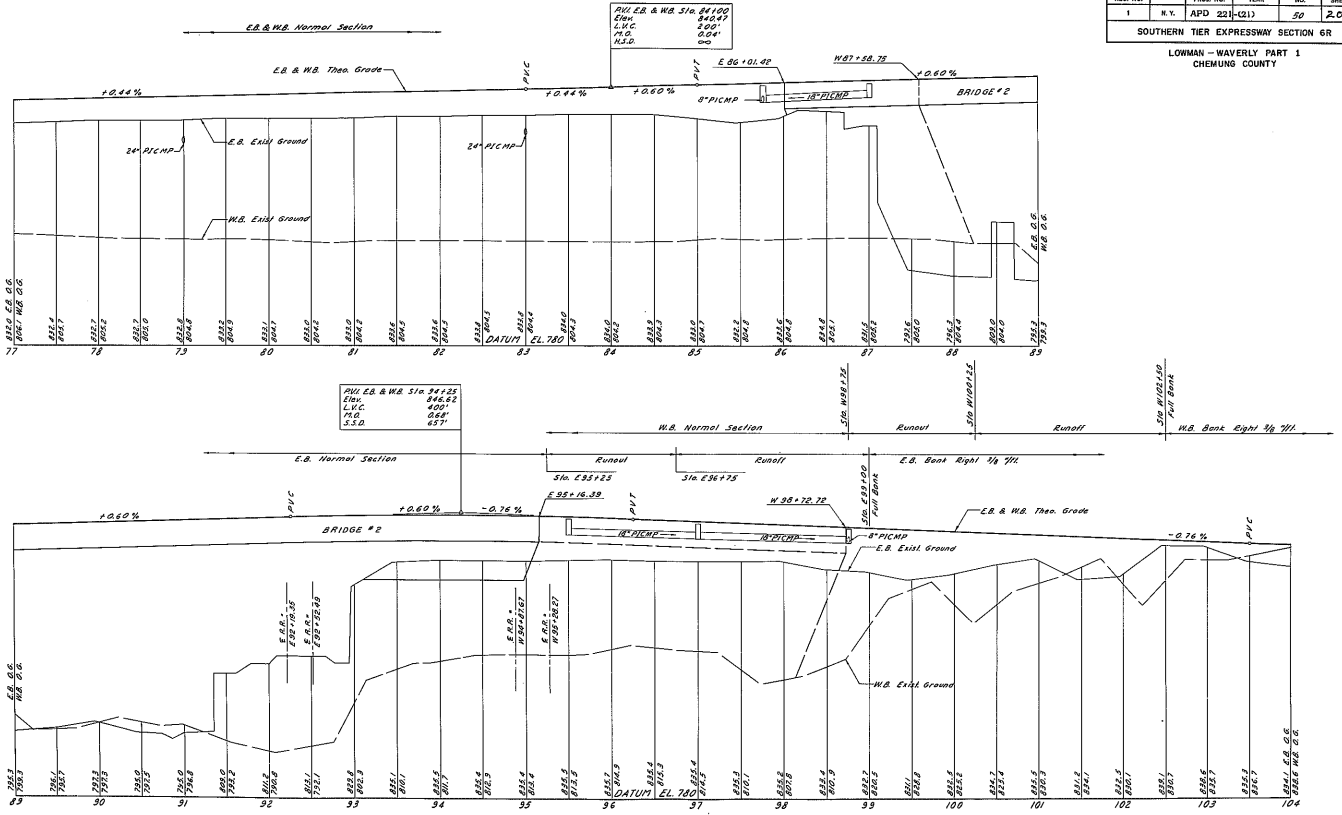


PLATE 27-4

FED. ROAD DIST. NO.	STATE	FED. AID PROJ. NO.	FISCAL YEAR	SHEET NO.	TOTAL SHEETS
1	K.Y.	APD 221-(21)	50	200	

SOUTHERN TIER EXPRESSWAY SECTION 6R
LOWMAN - WAVERLY PART 1
CHEMUNG COUNTY



By Order of: A.L.A.
Checked by: E.
Designed by: G.C.

Prepared and recommended by: *[Signature]*
GOODKIND & ODEA
Consulting Engineers

Date: 4/1/57

STAS. E.W. 77+00 TO 104+00

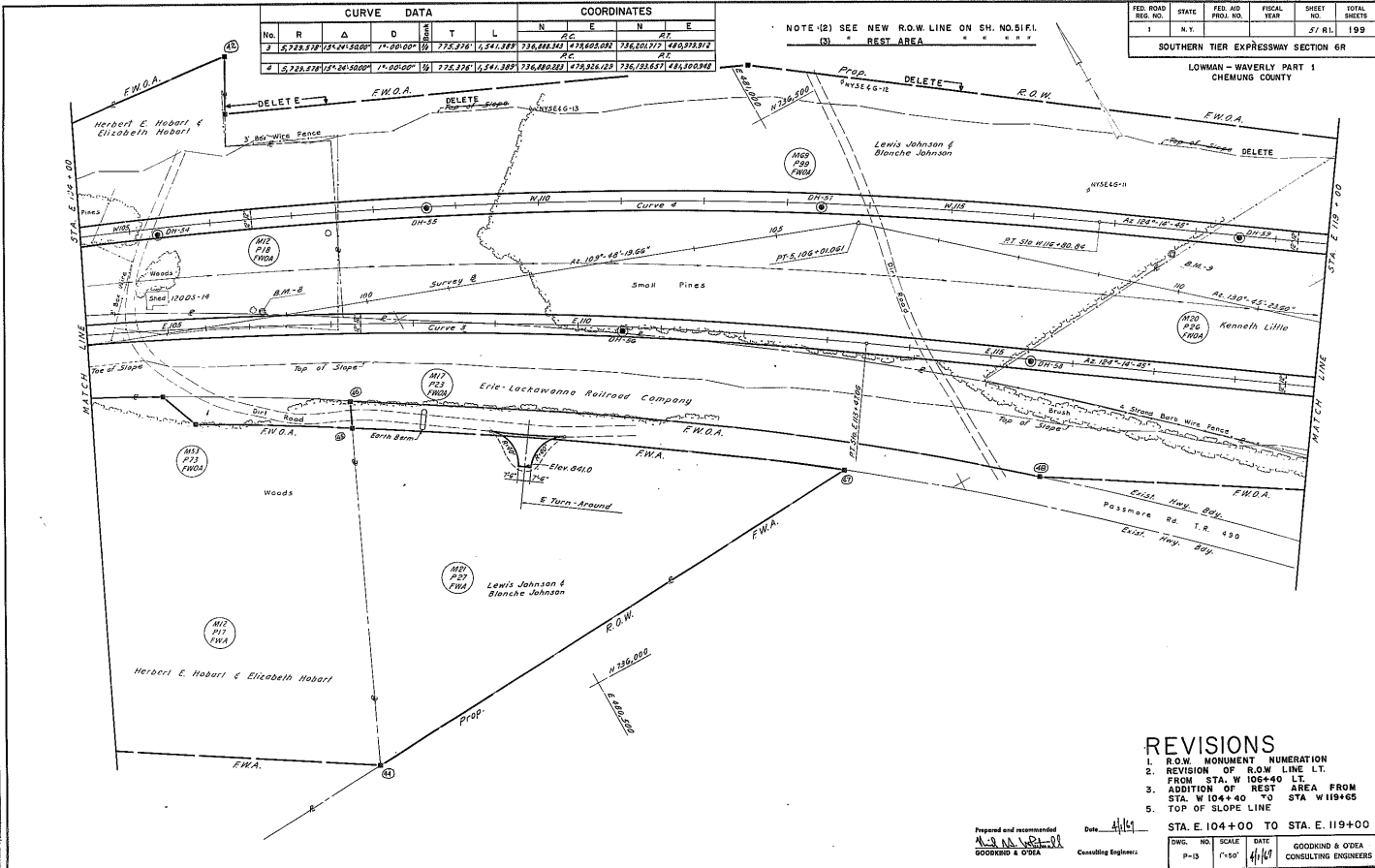
DWG. NO.	SCALE	DATE	GOODKIND & ODEA CONSULTING ENGINEERS
P-12	1" = 40'	4/1/57	

CURVE DATA						COORDINATES					
No.	R	Δ	D	S	T	L	N	E	N	E	
							PC	PT	PC	PT	
3	5,228.210	151°04'38.00"	1°-00'00"	10	775.378	1,541.389	736,886.313	1028,605.091	736,802.777	1,420,728.712	
4	5,228.210	151°04'38.00"	1°-00'00"	10	775.378	1,541.389	736,886.313	1028,605.091	736,802.777	1,420,728.712	

NOTE (2) SEE NEW R.O.W. LINE ON SH. NO. 81FL
(3) REST AREA

FED. ROAD REG. NO.	STATE	FED. AID PROJ. NO.	FISCAL YEAR	SHEET NO.	TOTAL SHEETS
1	N.Y.			57	199

SOUTHERN TIER EXPRESSWAY SECTION 6R
LOWMAN - WAVERLY PART 1
CHEMUNG COUNTY



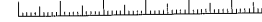
REVISIONS

1. R.O.W. MONUMENT NUMERATION
2. REVISION OF R.O.W. LINE L.T. FROM STA. W 104+40 L.T.
3. ADDITION OF REST AREA FROM STA. W 104+40 TO STA. W 119+65
5. TOP OF SLOPE LINE

Prepared and recommended: *[Signature]* Date: 4/11/11
GOODENO & O'NEA Consulting Engineers

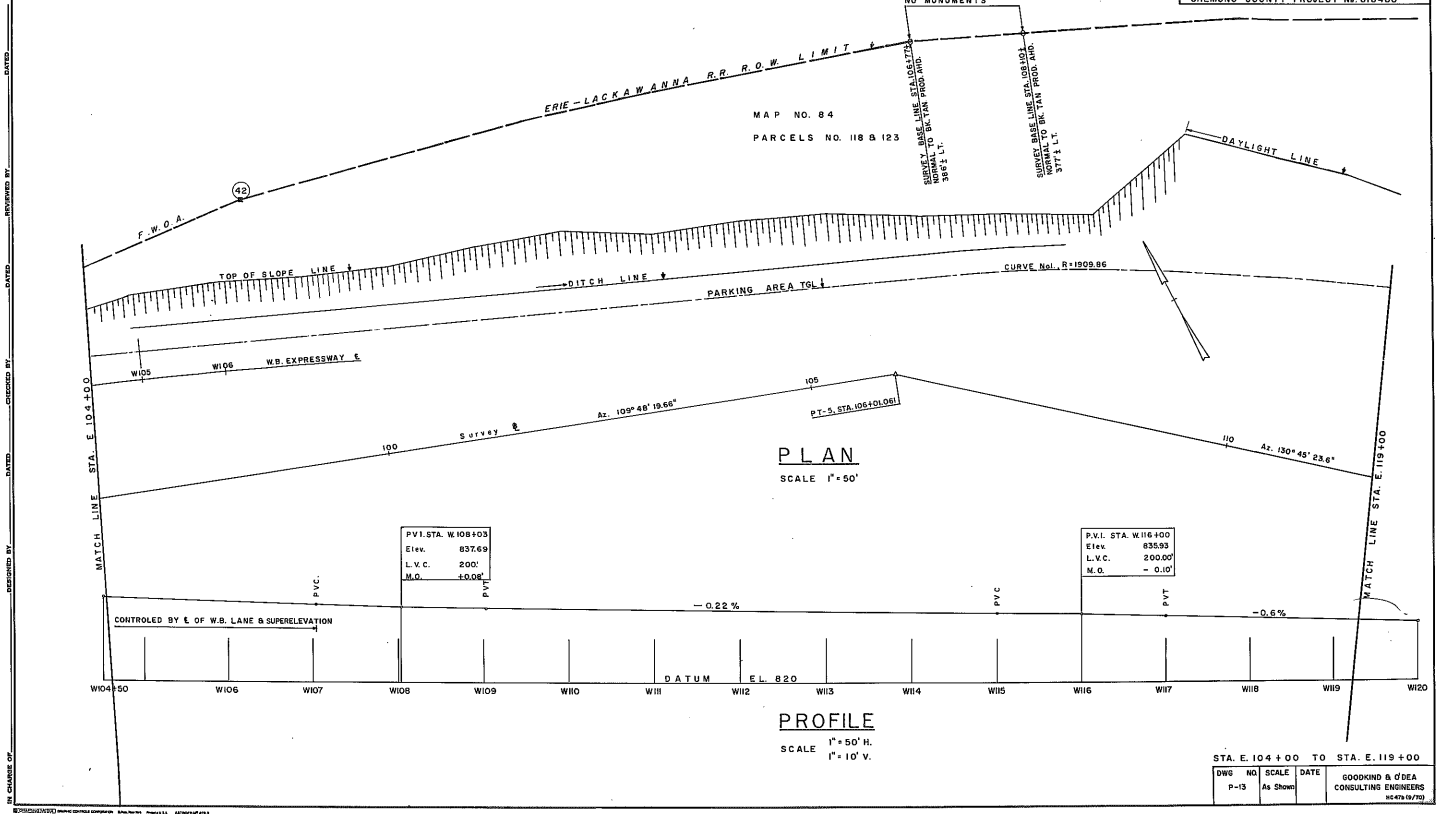
STA. E. 104+00	TO	STA. E. 119+00
DWG. NO.	SCALE	DATE
P-13	1"=50'	4/11/11

GOODENO & O'NEA CONSULTING ENGINEERS



MF 51R2 FIELD CHANGE SH.

FED. ROAD REG. NO.	STATE	FEDERAL AID PROJECT NO.	SHEET NO.	TOTAL SHEETS
1	N.Y.	APD-221 (21)	51-F1	199
LOWMAN-WAVERLY PT. I. F.A.S.T.E. 67-4				
SOUTHERN TIER EXPRESSWAY SECT. 6R				
PROPOSED SAFETY PARKING AREA SITE				
CHEMUNG COUNTY PROJECT No. 616400				

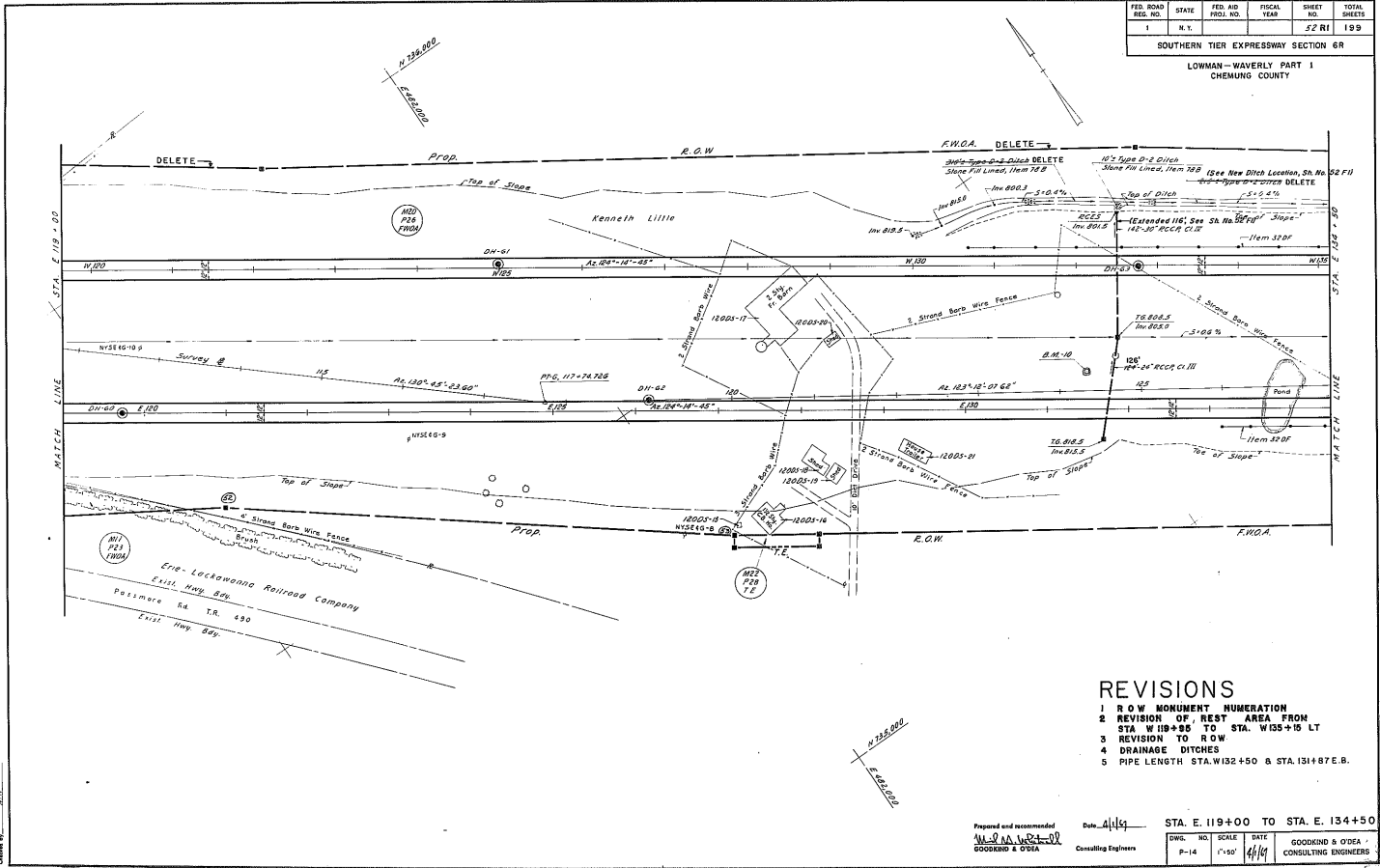


DWG. NO.	SCALE	DATE	GOODWIN & O'DEA CONSULTING ENGINEERS
P-13	As Shown		12/29/1972

DRAWN BY: [Name]
 CHECKED BY: [Name]
 DATE: [Date]

FED. ROAD REG. NO.	STATE	FED. AID PROJ. NO.	FISCAL YEAR	SHEET NO.	TOTAL SHEETS
1	N. Y.			52	119

SOUTHERN TIER EXPRESSWAY SECTION 6R
LOWMAN-WAVERLY PART 1
CHEMUNG COUNTY



- REVISIONS**
- 1 R.O.W MONUMENT HUMERATION
 - 2 REVISION OF REST AREA FROM STA. W118+85 TO STA. W135+15 LT
 - 3 REVISION TO R.O.W
 - 4 DRAINAGE DITCHES
 - 5 PIPE LENGTH STA. W132+50 & STA. 131+87 E.B.

Prepared and recommended by: *[Signature]* Date: *4/14* STA. E. 119+00 TO STA. E. 134+50
 GOODKIND & O'DEA Consulting Engineers

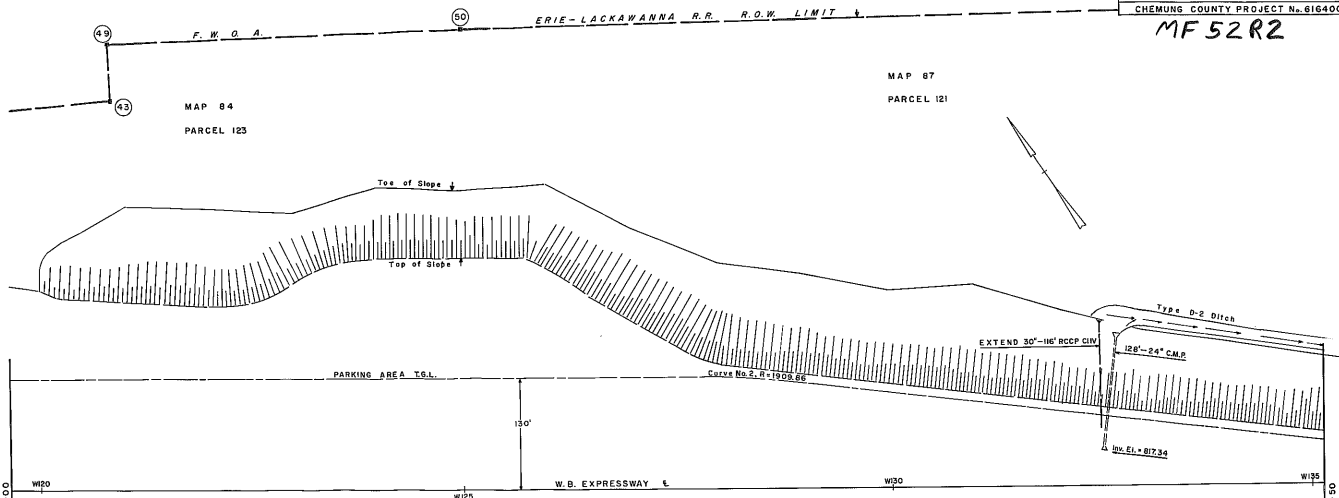
DWG. NO.	SCALE	DATE	GOODKIND & O'DEA CONSULTING ENGINEERS
P-14	1"=50'	4/14	

In Charge: *[Signature]*
 Checked By: *[Signature]*
 Date: *4/14*

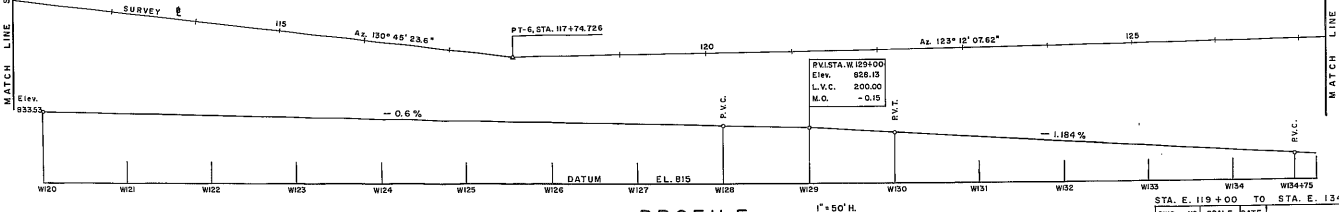
FIELD CHANGE SHEET

FED. ROAD REG. NO.	STATE	FEDERAL AID PROJECT NO.	SHEET NO.	TOTAL SHEETS
1	N.Y.	APD. 221-(2)	52-FI	199
LOWMAN-WAVERLY PT. I. F.A.S.T.E. 67-4				
SOUTHERN TIER EXPRESSWAY SECT. 6R				
PROPOSED SAFETY PARKING AREA SITE				
CHEMUNG COUNTY PROJECT No. 816400				

MF 52R2



PLAN SCALE 1" = 50'



PROFILE SCALE 1" = 50' H. 1" = 10' V.

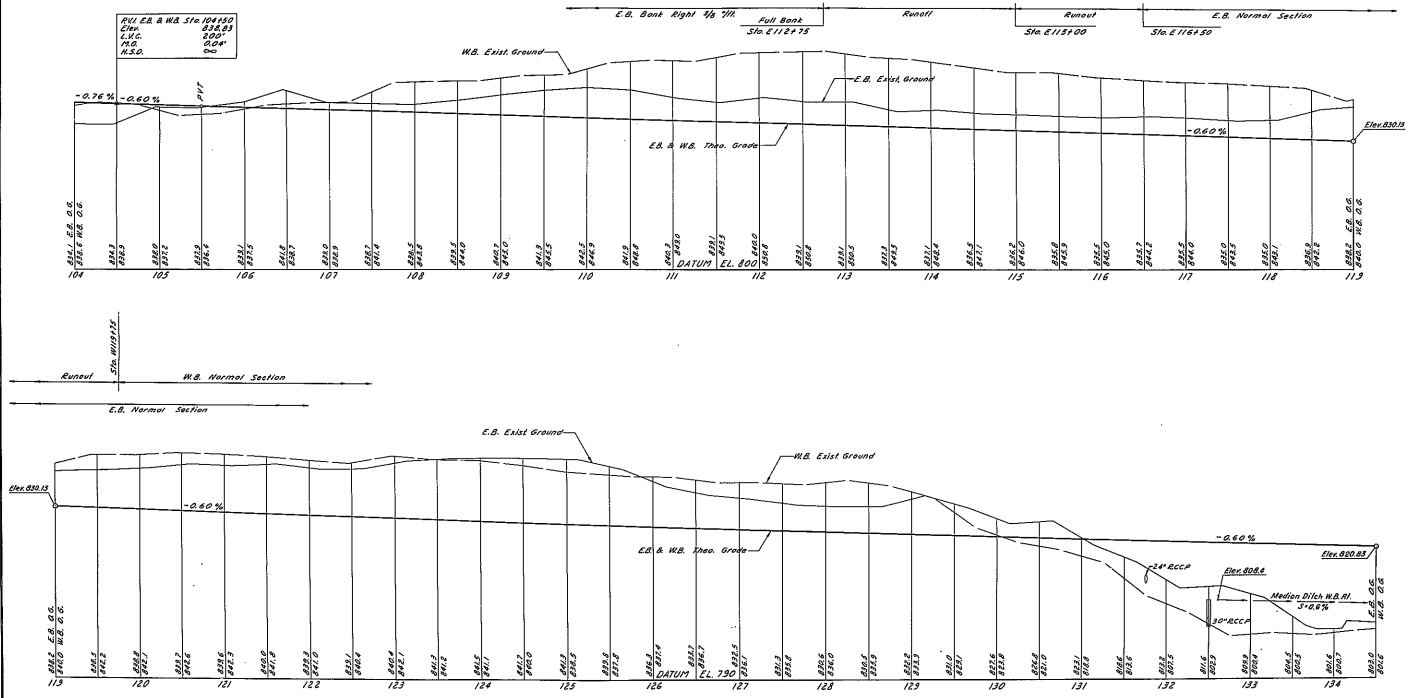
STA. E. 119+00	TO	STA. E. 134+50
DWG. NO. P-14	SCALE AS SHOWN	DATE AS SHOWN
GOODING & O'DEA CONSULTING ENGINEERS WASHINGTON		

IN CHARGE OF: _____
 DRAWN BY: _____
 CHECKED BY: _____
 REVIEWED BY: _____
 DATE: _____



FED. ROAD REG. NO.	STATE	FED. AID PROJ. NO.	FISCAL YEAR	SHEET NO.	TOTAL SHEETS
1	N.Y.	APD 221(C21)	53	100	200

SOUTHERN TIER EXPRESSWAY SECTION 6R
 LOWMAN - WAVERLY PART 1
 CHEMUNG COUNTY

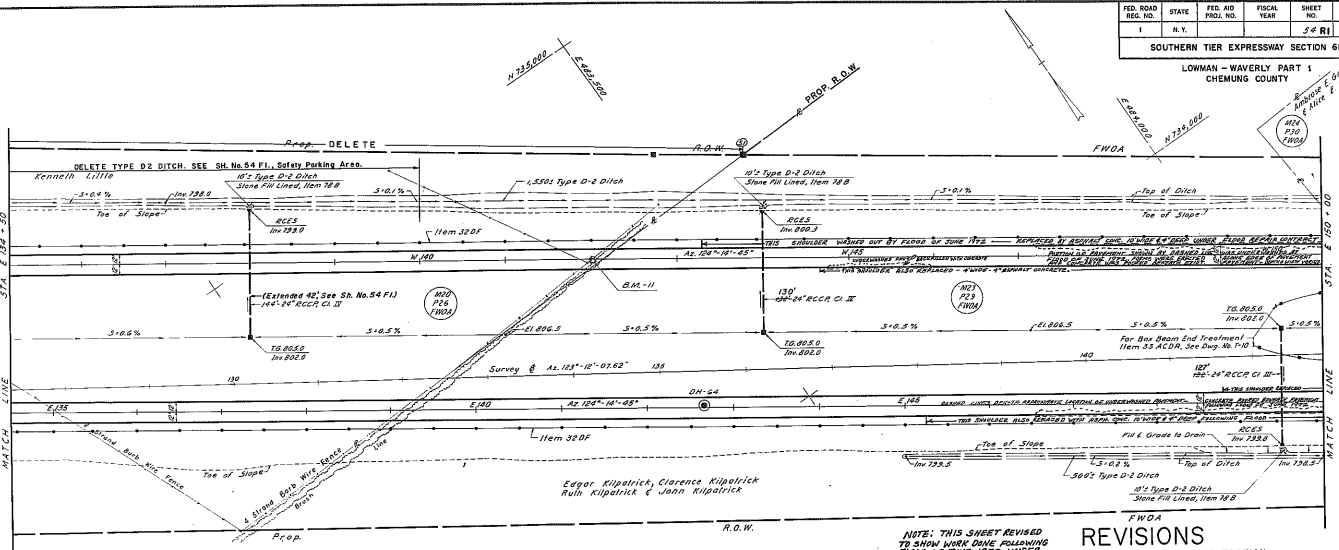


Prepared and recommended by: **A. D. V. B. & O'DEA**
 Consulting Engineers
 Date: 4/1/49
 STAS. E B W 104+00 TO 134+00
 DWG. NO. P-15 SCALE DATE GOODING & O'DEA CONSULTING ENGINEERS

In Charge: A. D. V. B.
 Checked by: A. D. V. B.
 Drawn by: A. D. V. B.

FED. ROAD DIST. NO.	STATE	FED. AID PROJ. NO.	FISCAL YEAR	SHEET NO.	TOTAL SHEETS
1	N.Y.			24 R1	199

SOUTHERN TIER EXPRESSWAY SECTION 6R
LOWMAN - WAVERLY PART 1
CHEMUNG COUNTY

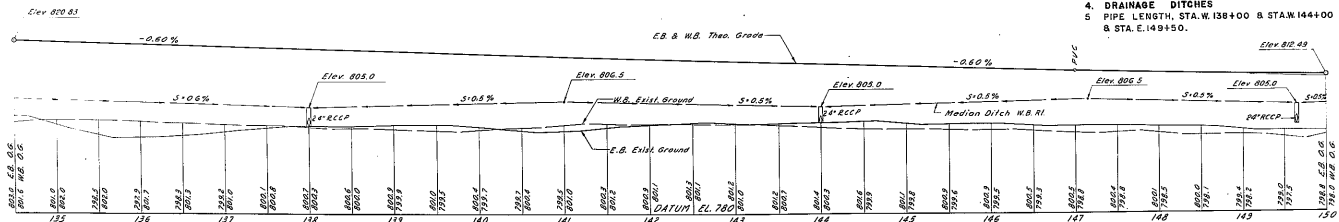


NOTE: THIS SHEET REVISED TO SHOW WORK DONE FOLLOWING COMPLETION OF THE EMERGENCY REPAIR CONTRACT.

1. REMOVE TO UNDESIRABLE PAVEMENT
2. REPLACEMENT OF WASHED OUT SANDWALERS

REVISIONS

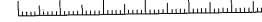
1. R.O.W. MONUMENT NUMERATION
2. REVISION OF R.O.W. FROM STA. W 119+65 TO W 100+25 LT.
3. ADDITION OF REST AREA FROM STA. W 119+65 TO STA. W 141+89 RT.
4. DRAINAGE DITCHES
5. PIPE LENGTH, STA. W 138+00 & STA. W 144+00 & STA. E. 149+50.



No. 1
 No. 2
 No. 3
 No. 4
 No. 5
 No. 6
 No. 7
 No. 8
 No. 9
 No. 10
 No. 11
 No. 12
 No. 13
 No. 14
 No. 15
 No. 16
 No. 17
 No. 18
 No. 19
 No. 20
 No. 21
 No. 22
 No. 23
 No. 24
 No. 25
 No. 26
 No. 27
 No. 28
 No. 29
 No. 30
 No. 31
 No. 32
 No. 33
 No. 34
 No. 35
 No. 36
 No. 37
 No. 38
 No. 39
 No. 40
 No. 41
 No. 42
 No. 43
 No. 44
 No. 45
 No. 46
 No. 47
 No. 48
 No. 49
 No. 50
 No. 51
 No. 52
 No. 53
 No. 54
 No. 55
 No. 56
 No. 57
 No. 58
 No. 59
 No. 60
 No. 61
 No. 62
 No. 63
 No. 64
 No. 65
 No. 66
 No. 67
 No. 68
 No. 69
 No. 70
 No. 71
 No. 72
 No. 73
 No. 74
 No. 75
 No. 76
 No. 77
 No. 78
 No. 79
 No. 80
 No. 81
 No. 82
 No. 83
 No. 84
 No. 85
 No. 86
 No. 87
 No. 88
 No. 89
 No. 90
 No. 91
 No. 92
 No. 93
 No. 94
 No. 95
 No. 96
 No. 97
 No. 98
 No. 99
 No. 100

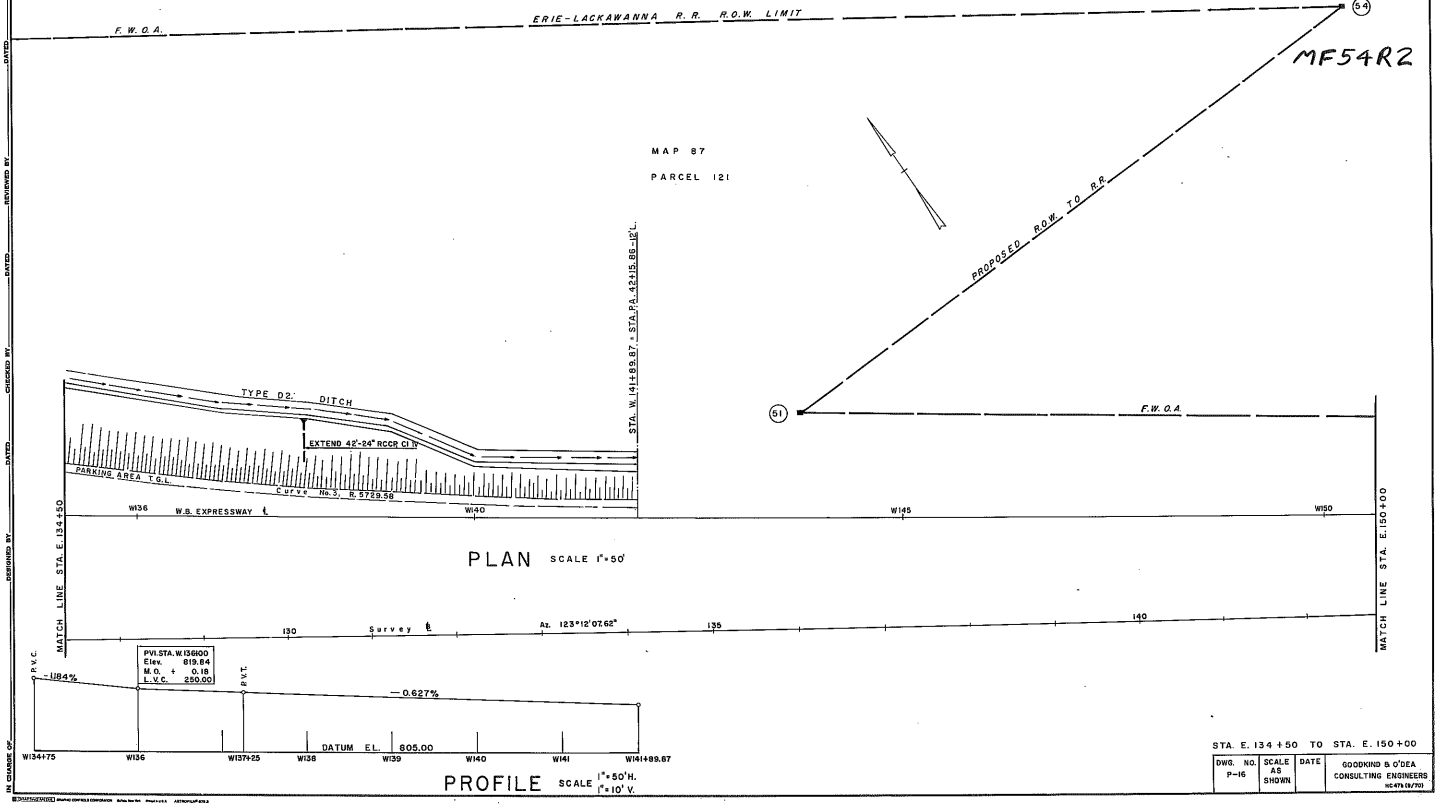
Proposed and recommended
 J. M. [Signature]
 GOODKIND & O'DEA
 Consulting Engineers

Date: 4/1/49
 STA. E. 134+50 TO STA. E. 150+00
 DWG. NO. SCALE DATE
 P-16 1"=50' 4/1/49
 GOODKIND & O'DEA CONSULTING ENGINEERS



FIELD CHANGE SHEET

FED. ROAD DIST. NO.	STATE	FEDERAL AID PROJECT NO.	SHEET NO.	TOTAL SHEETS
1	N.Y.	A.P.D. 221-(21)	54-F1	199
LOWMAN-WAVERLY PT. I. F.A.S.T.E. 67-4				
SOUTHERN TIER EXPRESSWAY SECT. 6R				
PROPOSED SAFETY PARKING AREA SITE				
CHEMUNG COUNTY PROJECT No. 816400				



PLAN SCALE 1"=50'

PROFILE SCALE 1"=50' H. 1"=10' V.

DWG. NO.	SCALE AS SHOWN	DATE	GODDING & O'DEA CONSULTING ENGINEERS WASHINGTON
P-16			

DATE: _____ CHECKED BY: _____ DRAWN BY: _____

MATCH LINE STA. E. 134+50 MATCH LINE STA. E. 150+00

FED. ROAD DIST. NO.	STATE	FED. AID PROJ. NO.	FISCAL YEAR	SHEET NO.	TOTAL SHEETS
1	N.Y.			52 RL	199

SOUTHERN TIER EXPRESSWAY SECTION 6R
LOWMAN - WAVERLY PART 1
CHEMUNG COUNTY

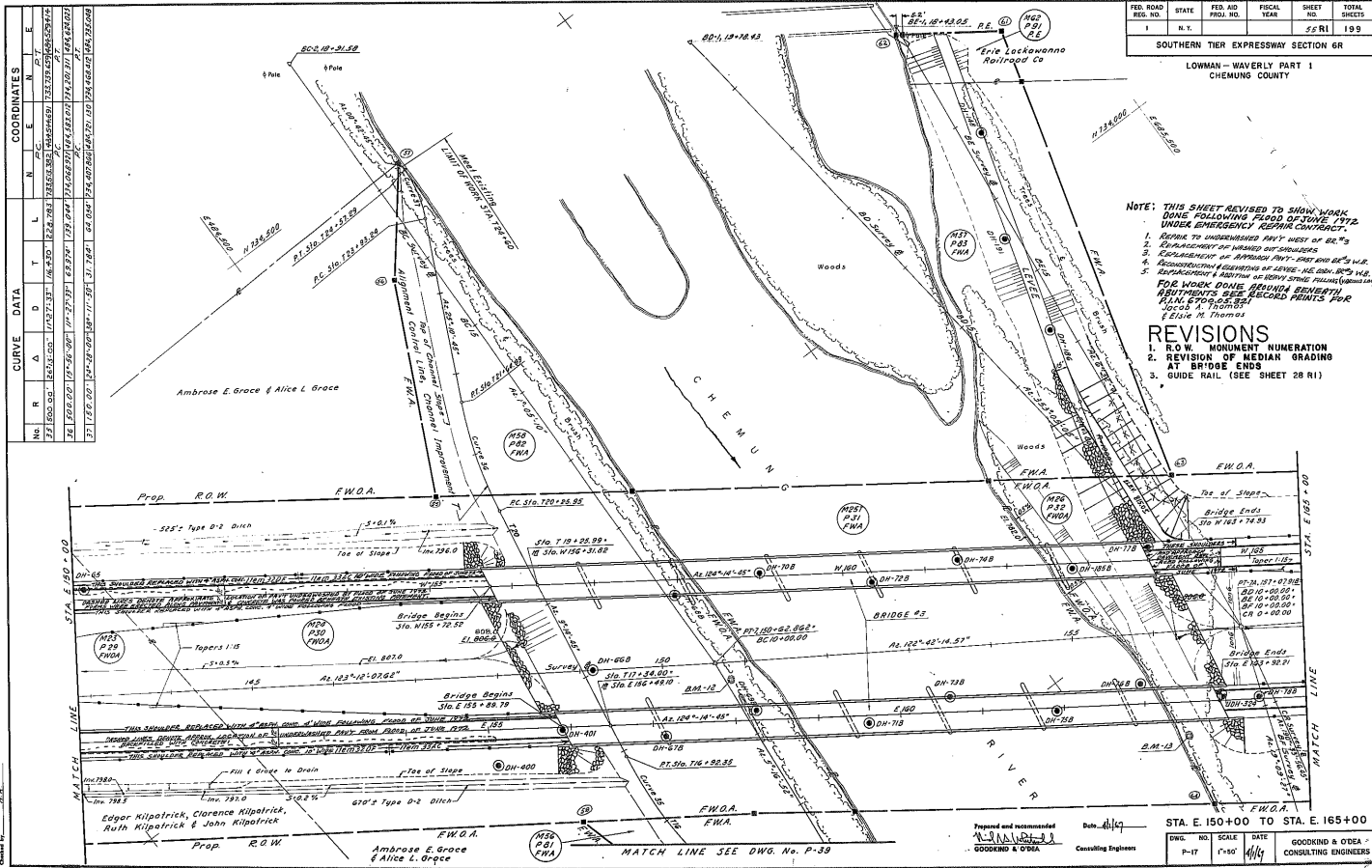
NOTE: THIS SHEET REVISED TO SHOW WORK DONE FOLLOWING FLOOD OF JUNE 1972 UNDER EMERGENCY CONTRACT.

1. BRIDGE TO UNDERPASS ANY WEST OF BE 50
2. REPLACEMENT OF INLAND AIR STRUCTURES
3. REPLACEMENT OF BRIDGE OVER JUNE AND DE STARS
4. RECONSTRUCTION OF GRADING OF LEVEE - SEE SHEET 52 RL 148
5. RECONSTRUCTION OF BRIDGE OF JOHN STONE PALMS (SEE SHEET 52 RL 148)

FOR WORK DONE BEYOND BRIDGE AT BRIDGE ENDS
ADJUSTMENTS SEE RECORD PRINTS FOR
JAMES M. THOMAS
E. CLIVE M. THOMAS

- REVISIONS**
1. R.O.W. MONUMENT NUMERATION
 2. REVISION OF MEDIAN GRADING AT BRIDGE ENDS
 3. GUIDE RAIL (SEE SHEET 28 R1)

No.	CURVE DATA		COORDINATES	
	A	D	N	E
1	172.00	172.00	172.00	172.00
2	172.00	172.00	172.00	172.00
3	172.00	172.00	172.00	172.00
4	172.00	172.00	172.00	172.00
5	172.00	172.00	172.00	172.00
6	172.00	172.00	172.00	172.00
7	172.00	172.00	172.00	172.00
8	172.00	172.00	172.00	172.00
9	172.00	172.00	172.00	172.00
10	172.00	172.00	172.00	172.00
11	172.00	172.00	172.00	172.00
12	172.00	172.00	172.00	172.00
13	172.00	172.00	172.00	172.00
14	172.00	172.00	172.00	172.00
15	172.00	172.00	172.00	172.00
16	172.00	172.00	172.00	172.00
17	172.00	172.00	172.00	172.00
18	172.00	172.00	172.00	172.00
19	172.00	172.00	172.00	172.00
20	172.00	172.00	172.00	172.00



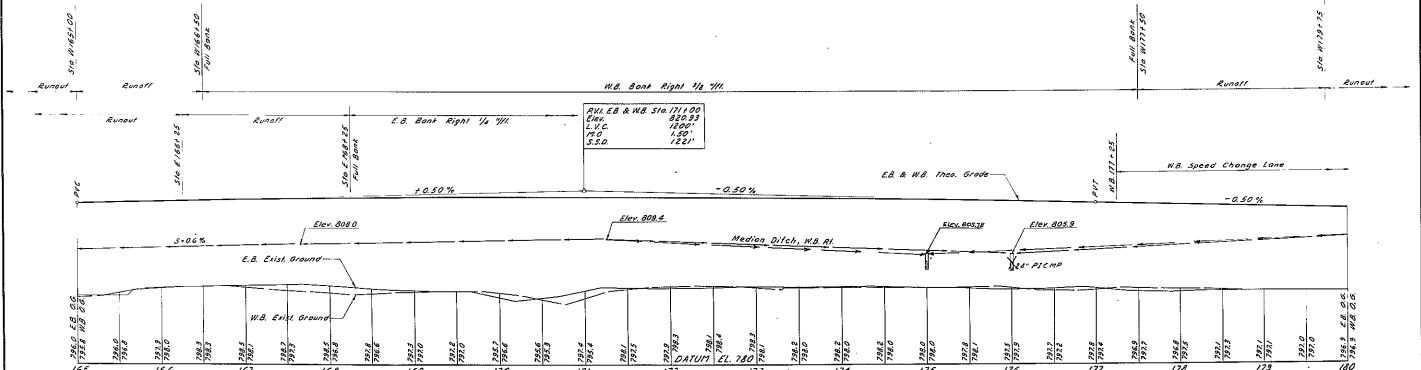
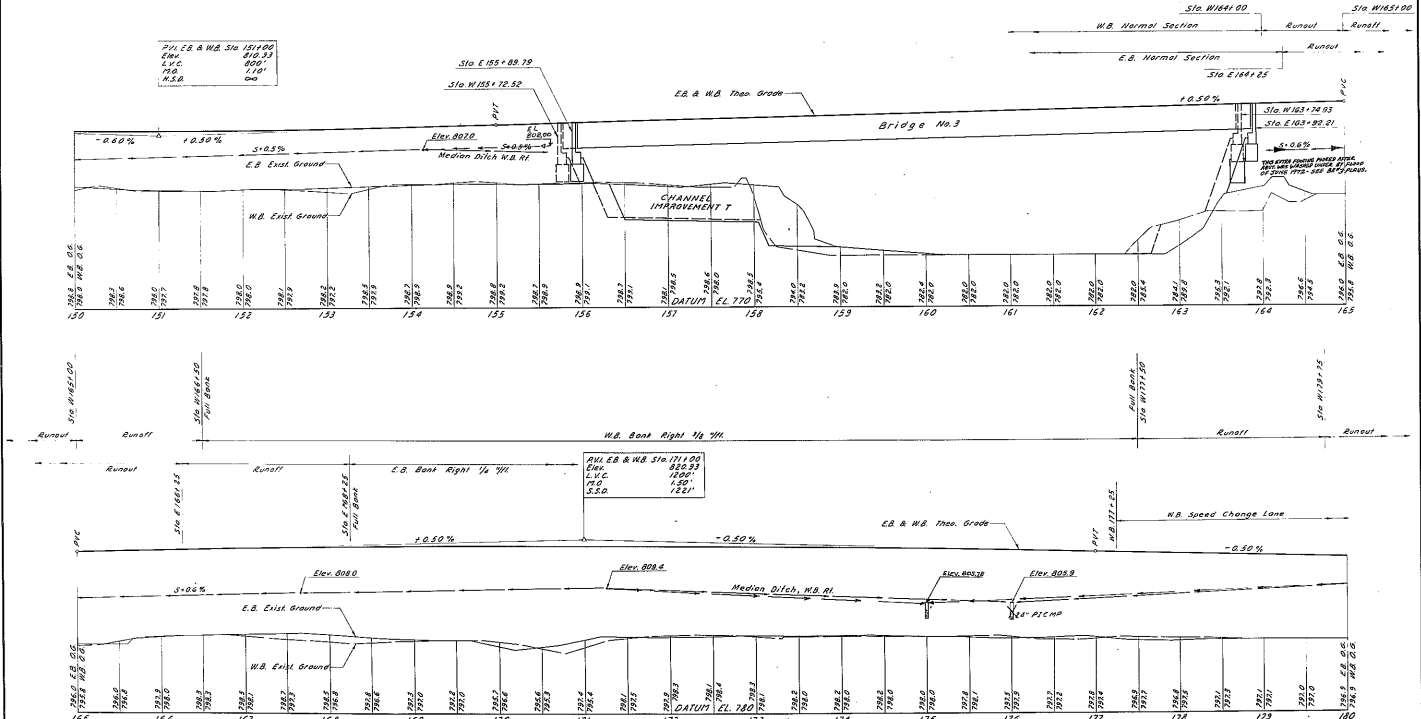
Prepared and recommended by: *[Signature]* Date: 4/1/77
 Consulting Engineers: GOODKIND & O'DEA
 STA. E. 150+00 TO STA. E. 165+00
 DWS. NO. P-17 SCALE 1"=50' DATE 4/1/77
 CONSULTING ENGINEERS

FED. ROAD DIST. NO.	STATE	FED. AID PROJ. NO.	FISCAL YEAR	SHEET NO.	TOTAL SHEETS
1	N.Y.	A.P.D. 221	(B)	57 B.L.	199

SOUTHERN TIER EXPRESSWAY SECTION 6R

LOWMAN - WAVERLY PART 1
CHEMUNG COUNTY

Full E.B. & W.B. Sta 151+00
C.M. 810.33
L.V.C. 850'
V.G. 1.0'
M.S.B. 0.0'



REVISIONS

- REVISION AT MEDIAN GRADING
- AT BRIDGE ENDS
- REVISED LOCATION OF CULVERT PIPE - STA. 175+00, MOVED TO E 175+00

Date: 4/1/49

STAS. E & W 150+00 TO 180+00

DATE	NO.	SCALE	DATE
P-19		1" = 50'	4/1/49

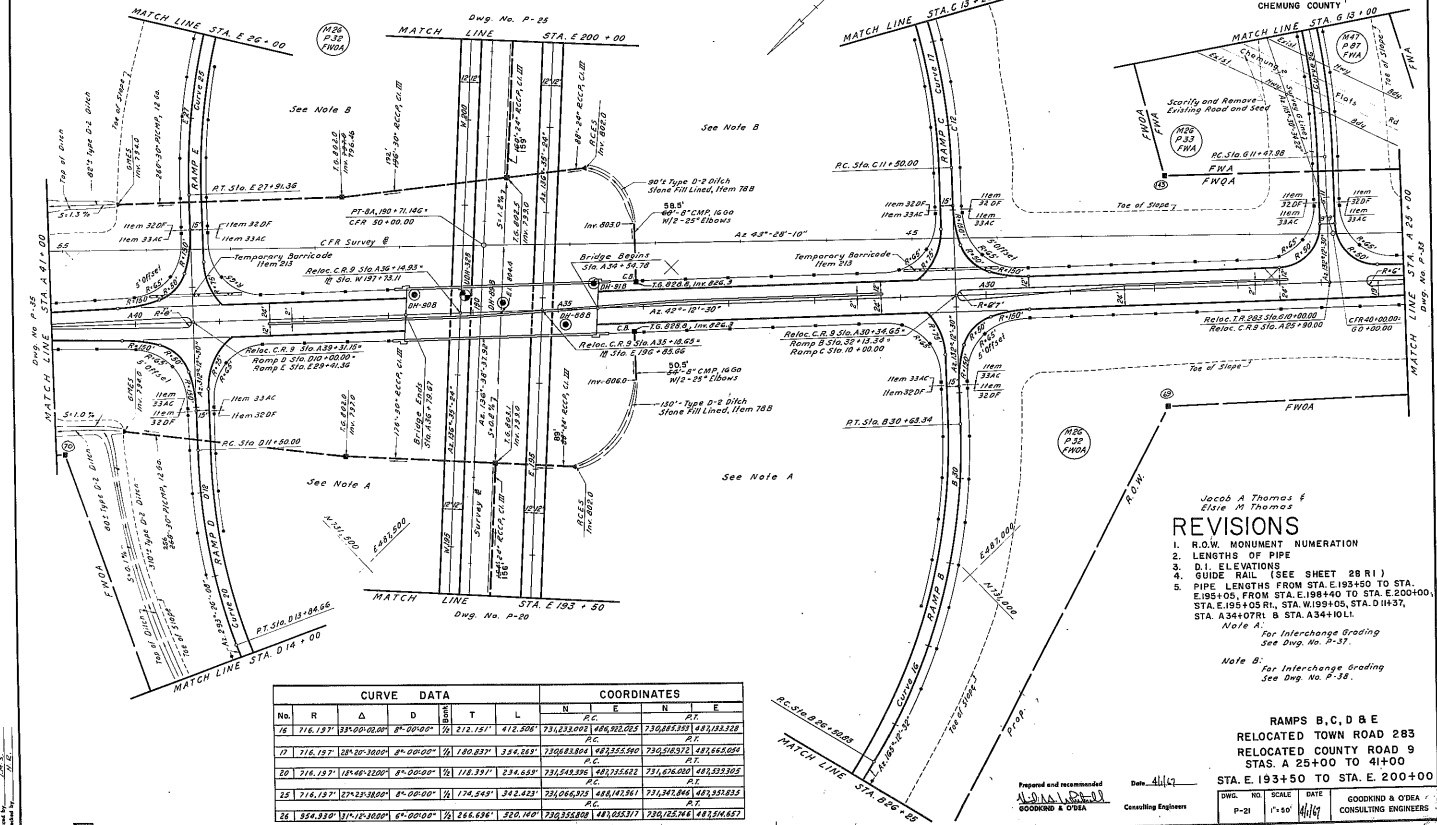
Consulting Engineers

GOODWIN & ODEA CONSULTING ENGINEERS

Vertical Curve
Data by
G.O.

SOUTHERN TIER EXPRESSWAY SECTION 6R
LOWMAN - WAVERLY PART I
CHEMUNG COUNTY

Jacob A. Thomas & Elsie M. Thomas



CURVE DATA						COORDINATES					
No.	R	Δ	D	T	L	N	E	N	E		
16	716.137'	33°00'00.00"	0°-00'00"	212.121'	472.500'	731,233.002	466,932.025	730,088.330	473,123.329		
17	216.197'	28°20'30.00"	2°-00'00"	180.837'	334.628'	730,088.330	466,932.025	730,548.971	481,668.084		
20	716.137'	12°40'20.00"	8°-00'00"	118.397'	234.629'	731,348.336	467,123.442	731,676.000	473,523.302		
22	716.137'	27°23'38.00"	4°-00'00"	174.548'	342.423'	731,676.000	467,123.442	732,342.846	481,351.823		
24	354.939'	17°12'18.00"	4°-00'00"	246.636'	320.140'	732,342.846	467,123.442	732,758.741	481,541.657		

REVISIONS

- R.O.W. MONUMENT NUMERATION
- LENGTHS OF PIPE
- D.I. ELEVATIONS
- GUIDE RAIL (SEE SHEET 28 R1)
- PIPE LENGTHS FROM STA. E 193+50 TO STA. E 195+05, FROM STA. E 198+40 TO STA. E 200+00, STA. E 195+05 RL, STA. W 199+05, STA. D 14+37, STA. A 34+07 RL, B STA. A 34+10 L.

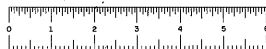
Note A: For Interchange Grading see Dwg. No. P-37.
Note B: For Interchange Grading see Dwg. No. P-38.

RAMPS B, C, D & E
RELOCATED TOWN ROAD 283
RELOCATED COUNTY ROAD 9
STAS. A 25+00 TO STA. E 200+00

Prepared and recommended by: *[Signature]*
GOODKIND & O'NEA
Consulting Engineers

Checked by: *[Signature]*
Consulting Engineers

Scale: 1" = 50'
Date: 11/14/19

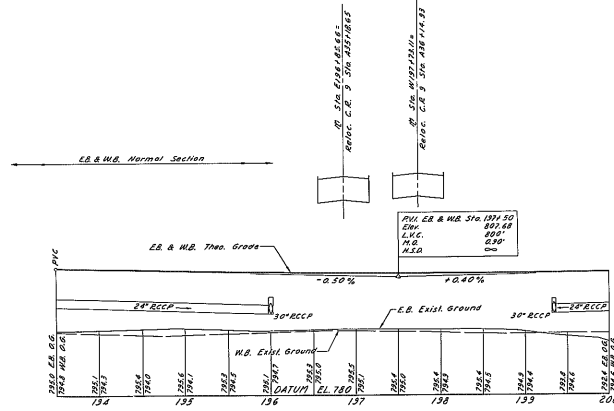
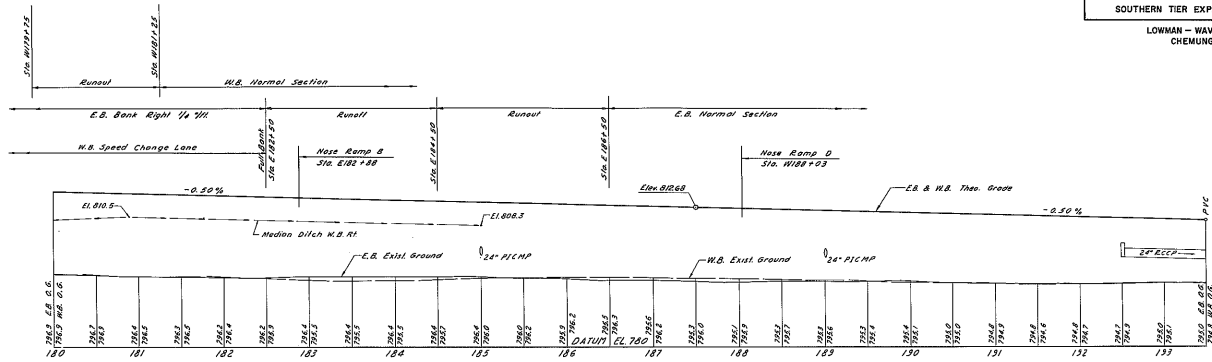


F.A.S.T.E. 67-4

FED. ROAD DIST. NO.	STATE	FED. AID PROJ. NO.	FISCAL YEAR	SHEET NO.	TOTAL SHEETS
1	N.Y.	APD 221-421	60	2.00	2.00

SOUTHERN TIER EXPRESSWAY SECTION 6R

LOWMAN - WAVERLY PART 1
CHEMUNG COUNTY

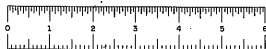


In Charge: A.J.D.
 Checked by: J.C.
 Drawn by: J.C.
 Contract No.: 67-4

Prepared and recommended by:

 GOODKIND & O'KEA Consulting Engineers

DATE: 4/1/71	STAS. E & W 180+00 TO 200+00
DWG. NO.: P-22	SCALE: 1" = 40' H, 1" = 10' V
DATE: 4/1/71	GOODKIND & O'KEA CONSULTING ENGINEERS

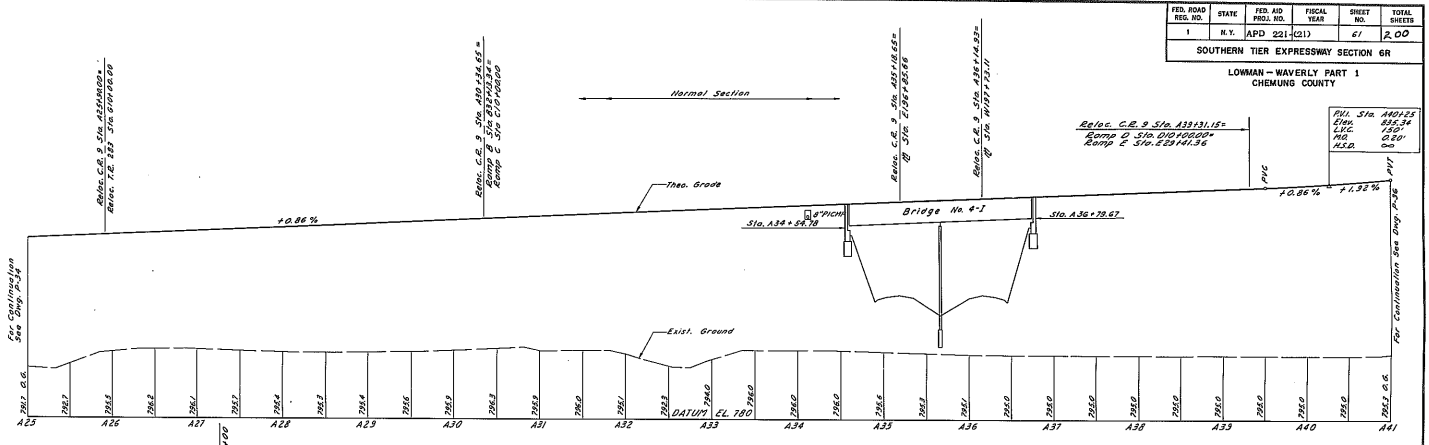


F.A.S.T.E 67-4

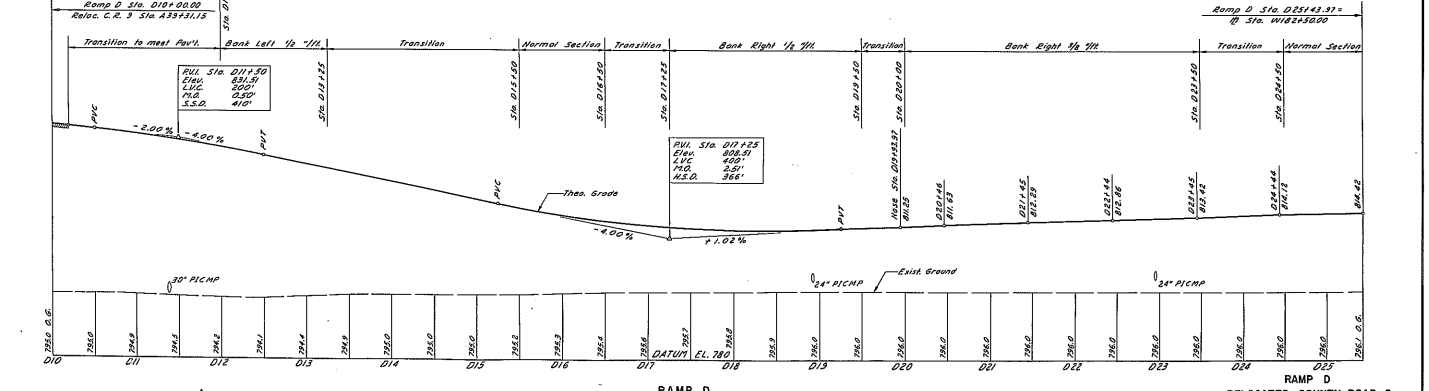
FED. ROAD DIST. NO.	STATE	FED. AID PROJ. NO.	FISCAL YEAR	SHEET NO.	TOTAL SHEETS
1	N.Y.	APD 221 (21)	67	200	

LOWMAN - WAVERLY PART I
CHEMUNG COUNTY

PVI Sta. 4001.25	2.00%
EL. 855.35	
L.S.C. 150'	
H.S.C. 600'	
M.S.C. 366'	



RELOCATED COUNTY ROAD 9



RAMP D

RAMP D
RELOCATED COUNTY ROAD 9
STAS. A 25+00 TO 44+00

Prepared and recommended

 Consulting Engineers

Date: 4/19

DWG. NO.	SCALE	DATE	GOODKIND & ODEA
P-23	1" = 40'	4/19	CONSULTING ENGINEERS

In Charge: G. H. ...
 Designer: G. H. ...
 Checker: G. H. ...

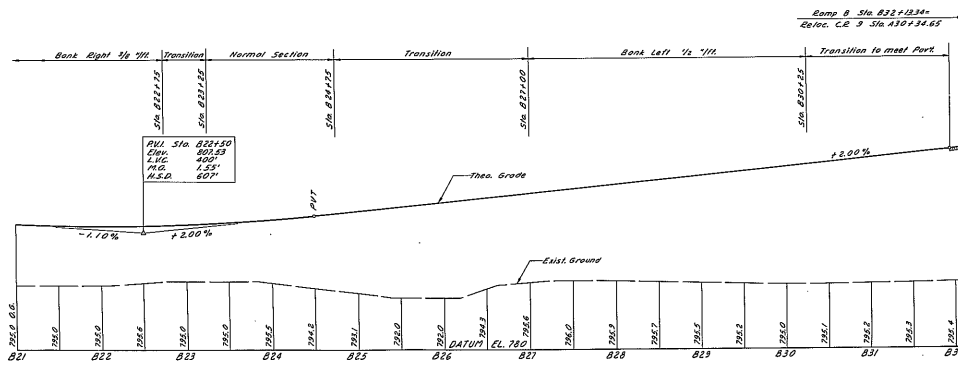
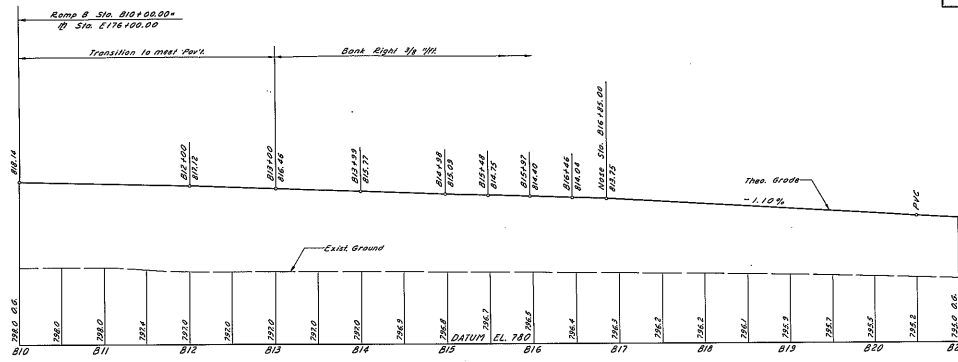


F.A.S.T.E. 67-4

FED. ROAD DIST. NO.	STATE	FED. AID PROJ. NO.	FISCAL YEAR	SHEET NO.	TOTAL SHEETS
1	N.Y.	APD 221-011	67	22	200

SOUTHERN TIER EXPRESSWAY SECTION 6R

LOWMAN - WAVERLY PART 1
CHEMUNG COUNTY



In Charge: J.P.P.
 Made By: G.C.K.S.
 Checked By: G.C.

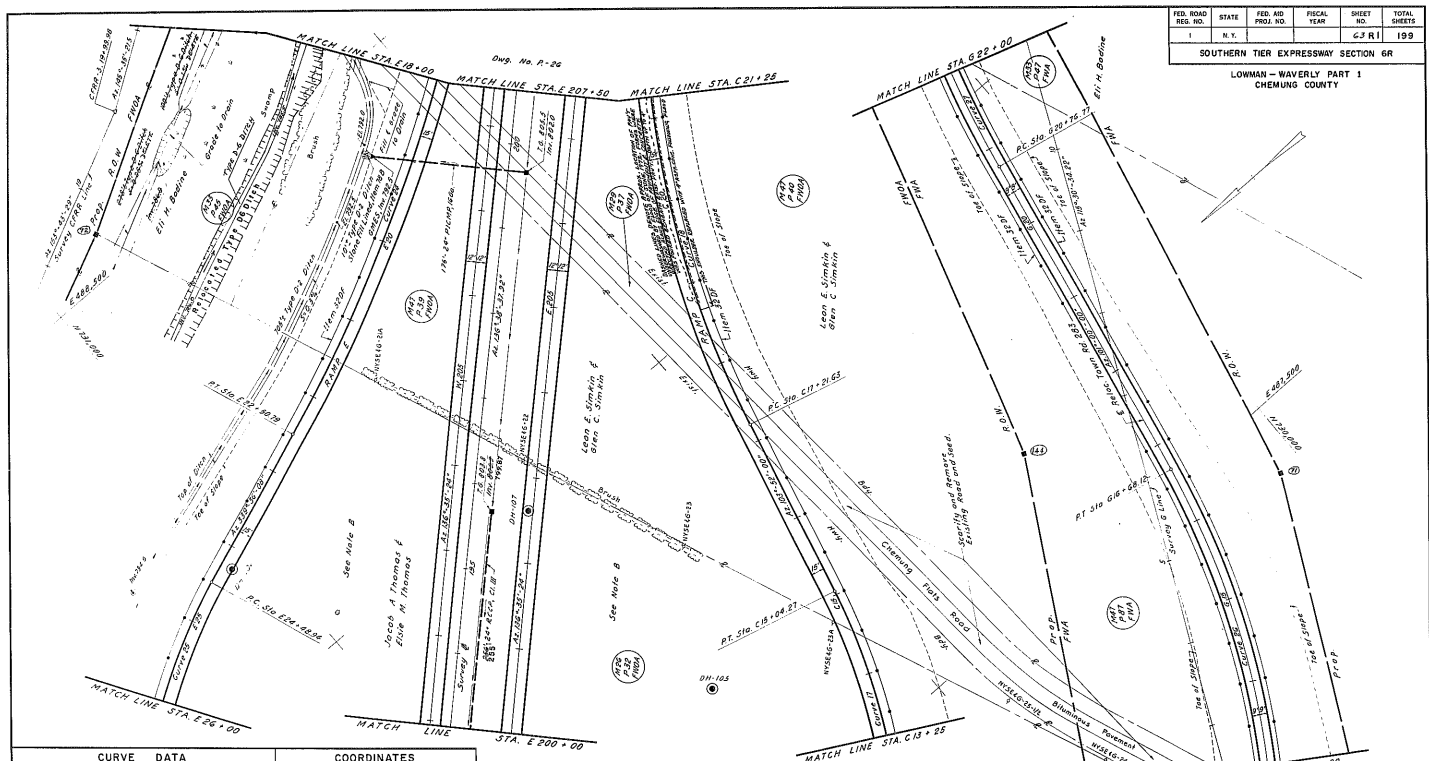
Prepared and recommended
 G.O.O. & O.E.A.
 Consulting Engineers

Date: 4/1/67

RAMP B				
DWG. NO.	SCALE	DATE	GOODKIND & OJEA CONSULTING ENGINEERS	
P-24	1" = 50'	4/1/67		

FED. ROAD REG. NO.	STATE	FED. AID PROJ. NO.	FISCAL YEAR	SHEET NO.	TOTAL SHEETS
1	N.Y.			CJ R1	199

SOUTHERN TIER EXPRESSWAY SECTION 6R
LOWMAN - WAVERLY PART 1
CHEMUNG COUNTY



CURVE DATA						COORDINATES					
No.	R	Δ	D	T	L	N	E	N	E	P.C.	P.T.
22	716.197	28°20'30.00"	0°50'00"	180.817	374.268	736623.004	423355.540	7361183.771	421645.604	P.C.	P.T.
23	1,143.318	67°00'40.00"	8°00'00"	726.383	543.557	736166.877	423376.082	7362018.616	422333.904	P.C.	P.T.
24	2,302.635	60°58'15.00"	3°00'00"	1,286.380	548.785	736281.640	426648.327	7362688.268	422212.024	P.C.	P.T.
25	716.197	27°52'32.00"	8°00'00"	714.549	342.427	736106.375	422471.361	7362322.864	421393.824	P.C.	P.T.
26	324.832	37°18'30.00"	8°00'00"	246.836	150.140	736355.808	421052.117	7362122.746	423214.687	P.C.	P.T.
27	1,143.318	17°40'00.00"	8°00'00"	771.228	340.000	736094.777	421272.728	7362314.024	422321.000	P.C.	P.T.

Dwg. No. P-21
NOTE: THIS SHEET REVISED TO SHOW WORK DONE UNDER EMERGENCY REPAIR CONTRACT FOLLOWING FLOOD OF JUNE, 1972.
1. REPAIR OF UNDERMINED APPROACH ON 'C' RAMP.
2. REPLACEMENT OF 30" WIDE 'C' RAMP.

- REVISIONS**
- R.O.W. MONUMENT NUMERATION
 - TYPE D-6 DITCH LOCATION
 - D.I. ELEVATION STA. E 202+56 LT.
 - GUIDE RAIL (SEE SHEET 28 R1)
 - PIPE LENGTH, MEDIAN, FROM STA. E200+00 TO E202+56

Note B: For Interchange Grading See Dwg. No. P-22

RAMPS C & E
RELOCATED TOWN ROAD 283
STA. E 200+00 TO STA. E 207+50

DATE: 4/1/71
SCALE: 1"=50'
CONSULTING ENGINEERS: GOODING & O'DEA

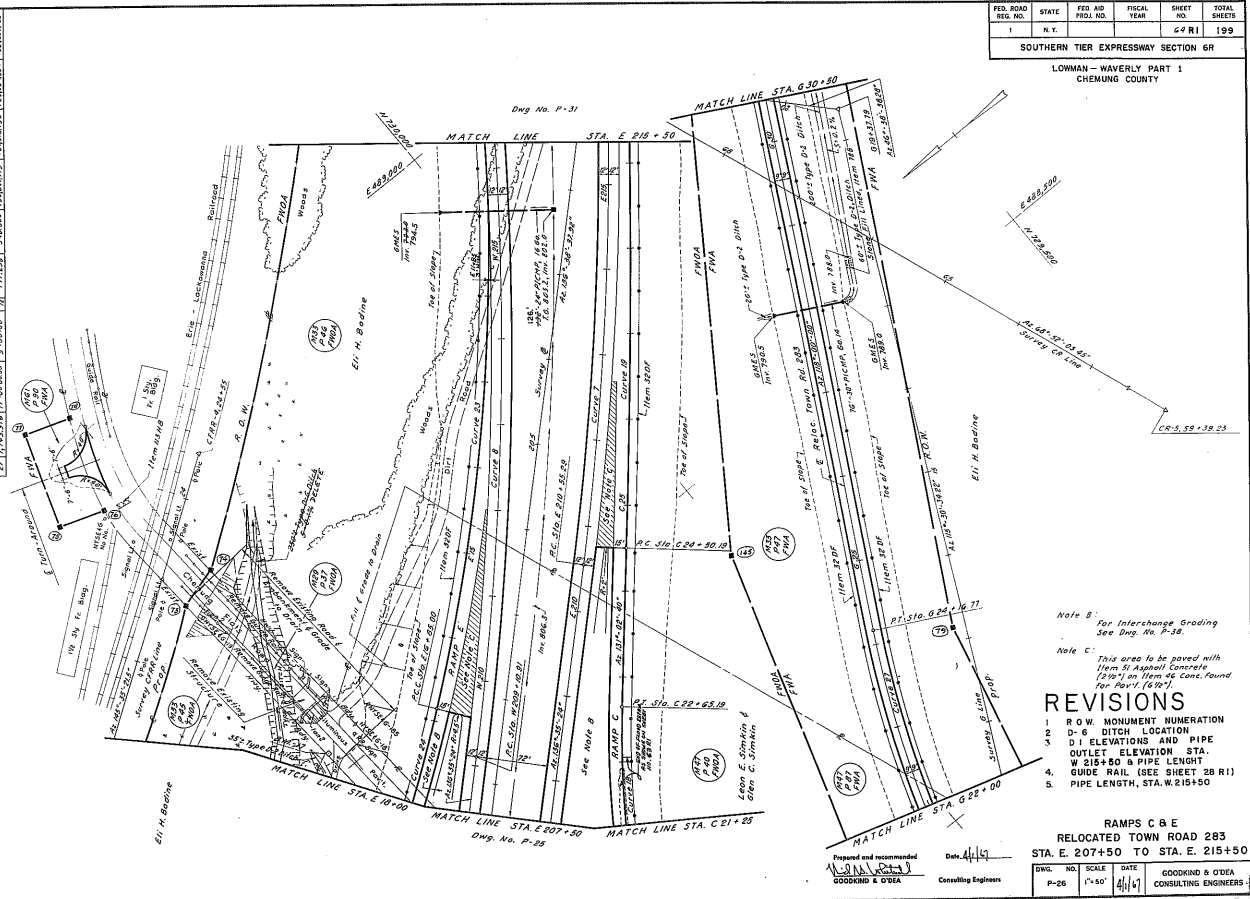
Date: 4/1/71
 Scale: 1"=50'
 Consulting Engineers: GOODING & O'DEA

FED. ROAD REG. NO.	STATE	FED AID PROJ. NO.	FISCAL YEAR	SHEET NO.	TOTAL SHEETS
1	N.Y.			64 R1	199

SOUTHERN TIER EXPRESSWAY SECTION 6R

LOWMAN - WAVERLY PART 1
CHEMUNG COUNTY

CURVE DATA		COORDINATES	
NO.	R	E	N
1	173.17	173.17	173.17
2	173.17	173.17	173.17
3	173.17	173.17	173.17
4	173.17	173.17	173.17
5	173.17	173.17	173.17
6	173.17	173.17	173.17
7	173.17	173.17	173.17
8	173.17	173.17	173.17
9	173.17	173.17	173.17
10	173.17	173.17	173.17
11	173.17	173.17	173.17
12	173.17	173.17	173.17
13	173.17	173.17	173.17
14	173.17	173.17	173.17
15	173.17	173.17	173.17
16	173.17	173.17	173.17
17	173.17	173.17	173.17
18	173.17	173.17	173.17
19	173.17	173.17	173.17
20	173.17	173.17	173.17
21	173.17	173.17	173.17
22	173.17	173.17	173.17
23	173.17	173.17	173.17
24	173.17	173.17	173.17
25	173.17	173.17	173.17
26	173.17	173.17	173.17
27	173.17	173.17	173.17
28	173.17	173.17	173.17
29	173.17	173.17	173.17
30	173.17	173.17	173.17
31	173.17	173.17	173.17
32	173.17	173.17	173.17
33	173.17	173.17	173.17
34	173.17	173.17	173.17
35	173.17	173.17	173.17
36	173.17	173.17	173.17
37	173.17	173.17	173.17
38	173.17	173.17	173.17
39	173.17	173.17	173.17
40	173.17	173.17	173.17
41	173.17	173.17	173.17
42	173.17	173.17	173.17
43	173.17	173.17	173.17
44	173.17	173.17	173.17
45	173.17	173.17	173.17
46	173.17	173.17	173.17
47	173.17	173.17	173.17
48	173.17	173.17	173.17
49	173.17	173.17	173.17
50	173.17	173.17	173.17
51	173.17	173.17	173.17
52	173.17	173.17	173.17
53	173.17	173.17	173.17
54	173.17	173.17	173.17
55	173.17	173.17	173.17
56	173.17	173.17	173.17
57	173.17	173.17	173.17
58	173.17	173.17	173.17
59	173.17	173.17	173.17
60	173.17	173.17	173.17
61	173.17	173.17	173.17
62	173.17	173.17	173.17
63	173.17	173.17	173.17
64	173.17	173.17	173.17
65	173.17	173.17	173.17
66	173.17	173.17	173.17
67	173.17	173.17	173.17
68	173.17	173.17	173.17
69	173.17	173.17	173.17
70	173.17	173.17	173.17
71	173.17	173.17	173.17
72	173.17	173.17	173.17
73	173.17	173.17	173.17
74	173.17	173.17	173.17
75	173.17	173.17	173.17
76	173.17	173.17	173.17
77	173.17	173.17	173.17
78	173.17	173.17	173.17
79	173.17	173.17	173.17
80	173.17	173.17	173.17
81	173.17	173.17	173.17
82	173.17	173.17	173.17
83	173.17	173.17	173.17
84	173.17	173.17	173.17
85	173.17	173.17	173.17
86	173.17	173.17	173.17
87	173.17	173.17	173.17
88	173.17	173.17	173.17
89	173.17	173.17	173.17
90	173.17	173.17	173.17
91	173.17	173.17	173.17
92	173.17	173.17	173.17
93	173.17	173.17	173.17
94	173.17	173.17	173.17
95	173.17	173.17	173.17
96	173.17	173.17	173.17
97	173.17	173.17	173.17
98	173.17	173.17	173.17
99	173.17	173.17	173.17
100	173.17	173.17	173.17



Note B: For Interchange Grading See Dog. No. P-26

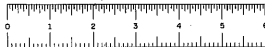
Note C: This area to be paved with Item 51 Asphalt Concrete (3 1/2") on Item 46 Conc. Found for Part (600')

- REVISIONS**
- 1 ROW MONUMENT NUMERATION
 - 2 D & S DITCH LOCATION
 - 3 D I ELEVATIONS AND PIPE OUTLET ELEVATION STA. W 215+50 & PIPE LENGTH
 - 4 GUIDE RAIL (SEE SHEET 28 R1)
 - 5 PIPE LENGTH, STA. W 215+50

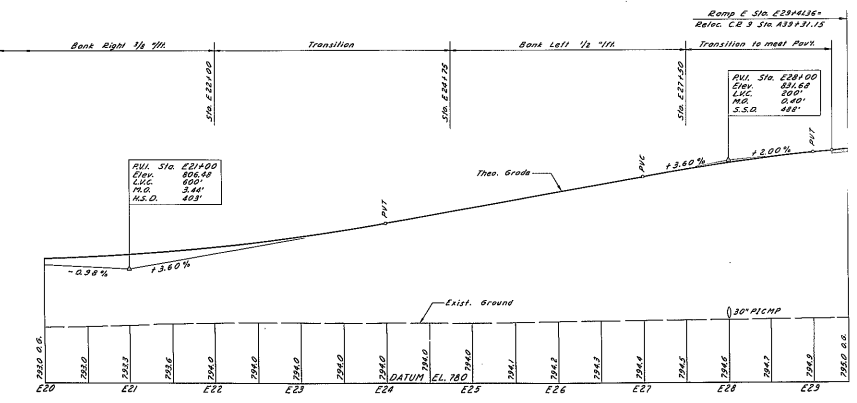
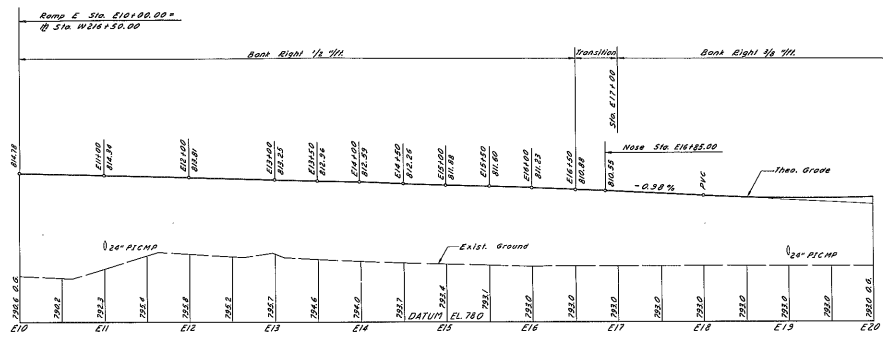
RAMPS C & E
RELOCATED TOWN ROAD 283
STA. E. 207+50 TO STA. E. 215+50

Prepared and recommended
Consulting Engineers
GOODKIND & O'DEA

DRAW. NO.	SCALE	DATE	GOODKIND & O'DEA CONSULTING ENGINEERS
P-26	1"=50'	4/1/51	



F.A.S. 118 67-4					
FED. ROAD REG. NO.	STATE	FED. AID PROJ. NO.	FISCAL YEAR	SHEET NO.	TOTAL SHEETS
1	N.Y.	AFD 221-(21)	66	66	200
SOUTHERN TIER EXPRESSWAY SECTION 6R					
LOWMAN - WAVERLY PART 1					
CHEMUNG COUNTY					

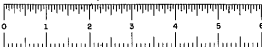


In Charge: J.P.P.
 Designer: J.P.P.
 Checker: J.P.P.
 Date: 4/1/67

Prepared and recommended by: *[Signature]*
 GODKIND & O'NEA
 Consulting Engineers

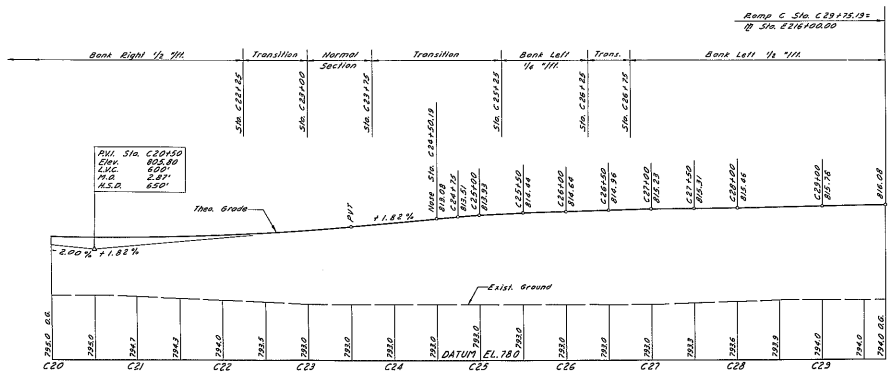
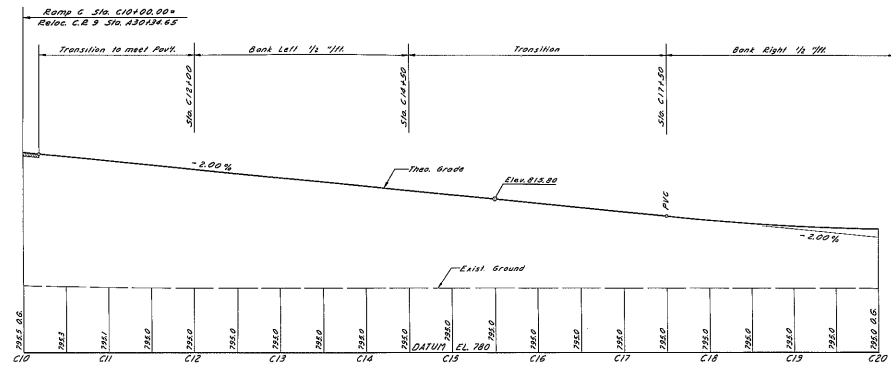
Date: 4/1/67
 Consulting Engineers

RAMP E			
DWG. NO.	SCALE	DATE	GODKIND & O'NEA CONSULTING ENGINEERS
P-28	1" = 50' H	4/1/67	



FED. ROAD DIST. NO.	STATE	FED. AID FISCAL YEAR	PROJECT NO.	SHEET NO.	TOTAL SHEETS
1	N.Y.	APD 221-(G1)	67	2	00

SOUTHERN TIER EXPRESSWAY SECTION 6R
 LOWMAN - WAVERLY PART 1
 CHEMUNG COUNTY



P.V.L. Sta. C20+50
 Elev. 825.80
 S.M.C. 680'
 M.R. 2.87'
 R.C.R. 650'

Prepared and recommended by: *[Signature]*
 GOODKIND & O'DEA
 Consulting Engineers

Date: 4/1/47

DWG. NO.	SCALE	DATE	ENGINEERS
P-29	1" = 40'	4/1/47	GOODKIND & O'DEA CONSULTING ENGINEERS

In Charge: *[Signature]*
 Checked: *[Signature]*
 Date: 4/1/47

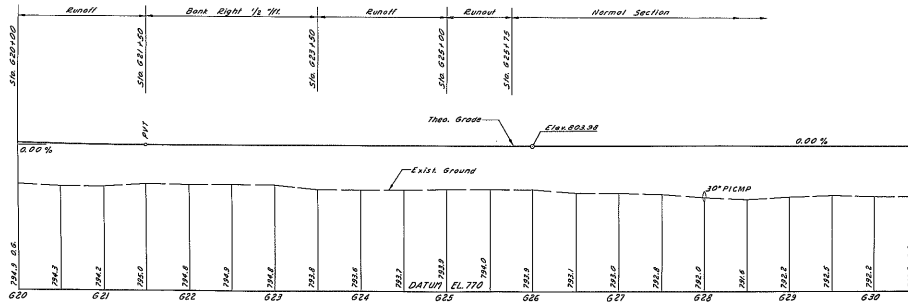
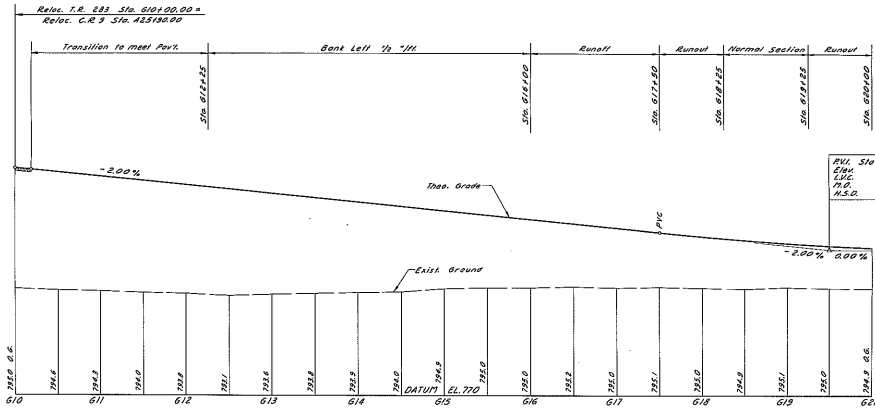


F.A.S.T.E. G7-4

FED. ROAD DIST. NO.	STATE	FED. AID PROJ. NO.	FISCAL YEAR	SHEET NO.	TOTAL SHEETS
1	N.Y.	APD 221	(21)	68	200

SOUTHERN TIER EXPRESSWAY SECTION 6R

LOWMAN - WAVELY PART 1
CHEMUNG COUNTY



Checked by: J.P.P.
 Drawn by: J.P.P.
 Date: 4/19/49

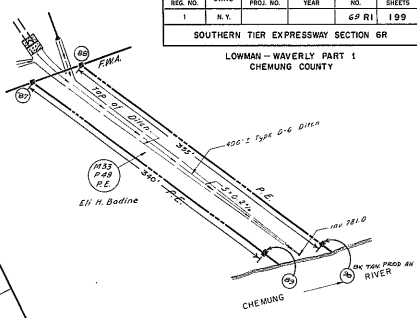
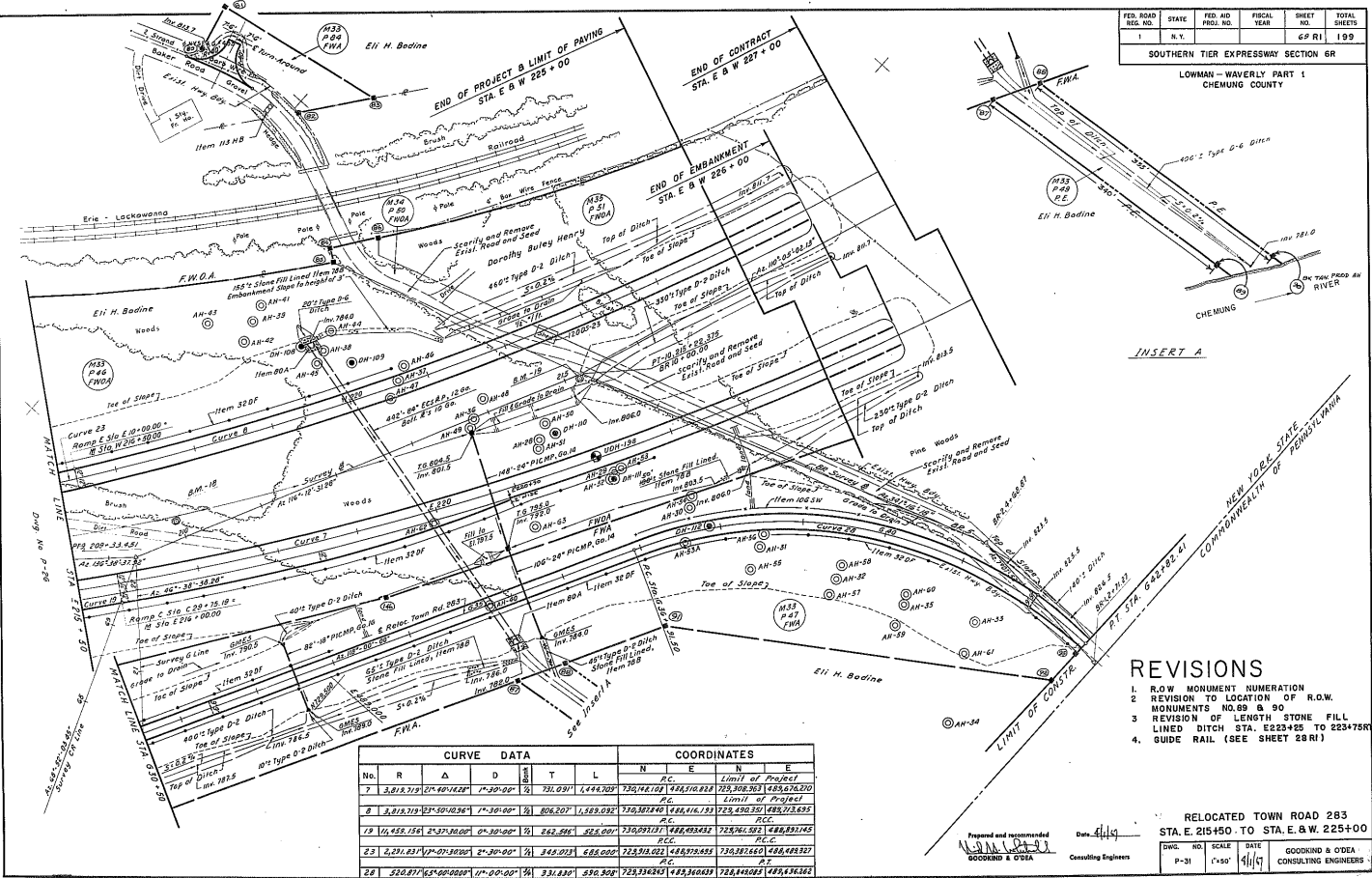
Prepared and recommended by: *[Signature]*
 Date: 4/19/49
 Consulting Engineers: GOODKIND & O'NEA

RELOCATED TOWN ROAD 263
STAS. G 10+00 TO 30+50

DWG. NO.	SCALE	DATE	GOODKIND & O'NEA CONSULTING ENGINEERS
P-30	1" = 40'	4/19/49	

FED. ROAD REG. NO.	STATE	FED. AID PROJ. NO.	FISCAL YEAR	SHEET NO.	TOTAL SHEETS
1	N.Y.			67 RI	109

SOUTHERN TIER EXPRESSWAY SECTION 6R
LOWMAN - WAVERLY PART 1
CHEMUNG COUNTY



INSERT A

REVISIONS

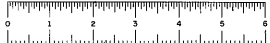
1. R.O.W MONUMENT NUMERATION
2. REVISION TO LOCATION OF R.O.W. MONUMENTS NO. 89 & 90
3. REVISION OF LENGTH STONE FILL LINED DITCH STA. E223+455 TO 223+750R
4. GUIDE RAIL (SEE SHEET 28R1)

CURVE DATA						COORDINATES			
No.	R	Δ	D	S	T	N	E	N	E
7	3,812.712	27°49'14.82"	1°30'00"	731.031	1,494.209	730,842.103	424,510.823	729,308.983	428,676.210
8	3,812.712	27°49'14.82"	1°30'00"	806.207	1,389.032	730,502.849	424,416.120	729,256.351	428,572.835
10	14,452.156	2°37'13.00"	0°30'00"	262.596	228.007	730,997.177	424,493.432	729,761.592	428,892.143
23	2,231.837	17°07'38.00"	2°30'00"	348.023	688.002	729,914.021	424,972.682	728,282.662	428,492.127
22	512.877	63°00'00.00"	0°00'00"	331.830	330.508	729,324.820	423,366.627	728,446.623	428,476.382

Prepared and recommended by: [Signature]
GOODKIND & O'DEA Consulting Engineers

DATE: 4/1/97
RELOCATED TOWN ROAD 283
STA. E. 215+50 TO STA. E. & W. 225+00
SCALE: 1"=50'
DATE: 4/1/97
GOODKIND & O'DEA CONSULTING ENGINEERS

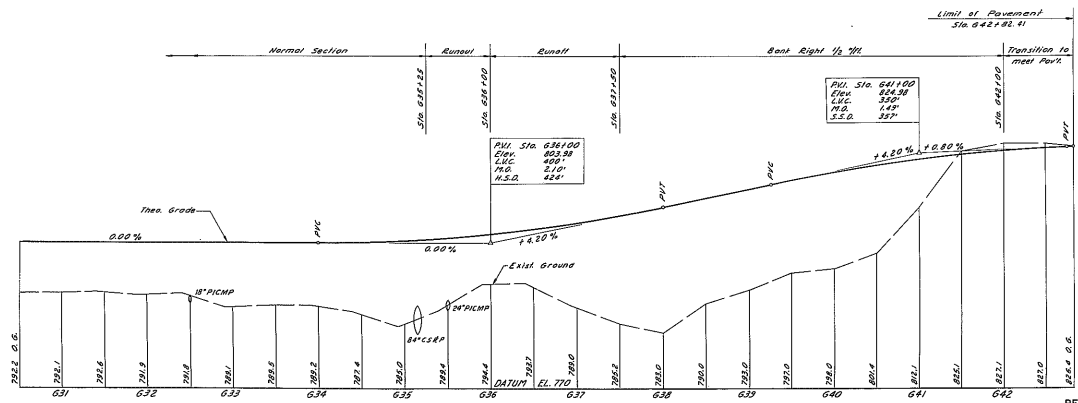
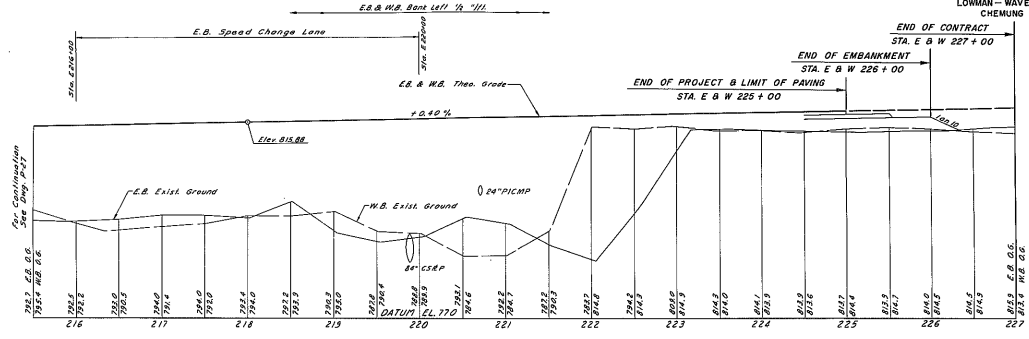
Scale: 1"=50'
Date: 4/1/97
Checked by: [Signature]



FED. ROAD REG. NO.	STATE	FED. AID PROJ. NO.	FISCAL YEAR	SHEET NO.	TOTAL SHEETS
1	N.C.	APD 221-021	70	70	200

SOUTHERN TIER EXPRESSWAY SECTION 6R

LOWMAN - WAVERLY PART 1
CHEMUNG COUNTY



RELOCATED TOWN ROAD 283

RELOCATED TOWN ROAD 283
STAS. 6 30+50 TO 42+63
STAS. E & W 215+50 TO 225+00

Prepared and recommended by: *[Signature]*
Date: 4/19/70
GOODKIND & ODEA Consulting Engineers

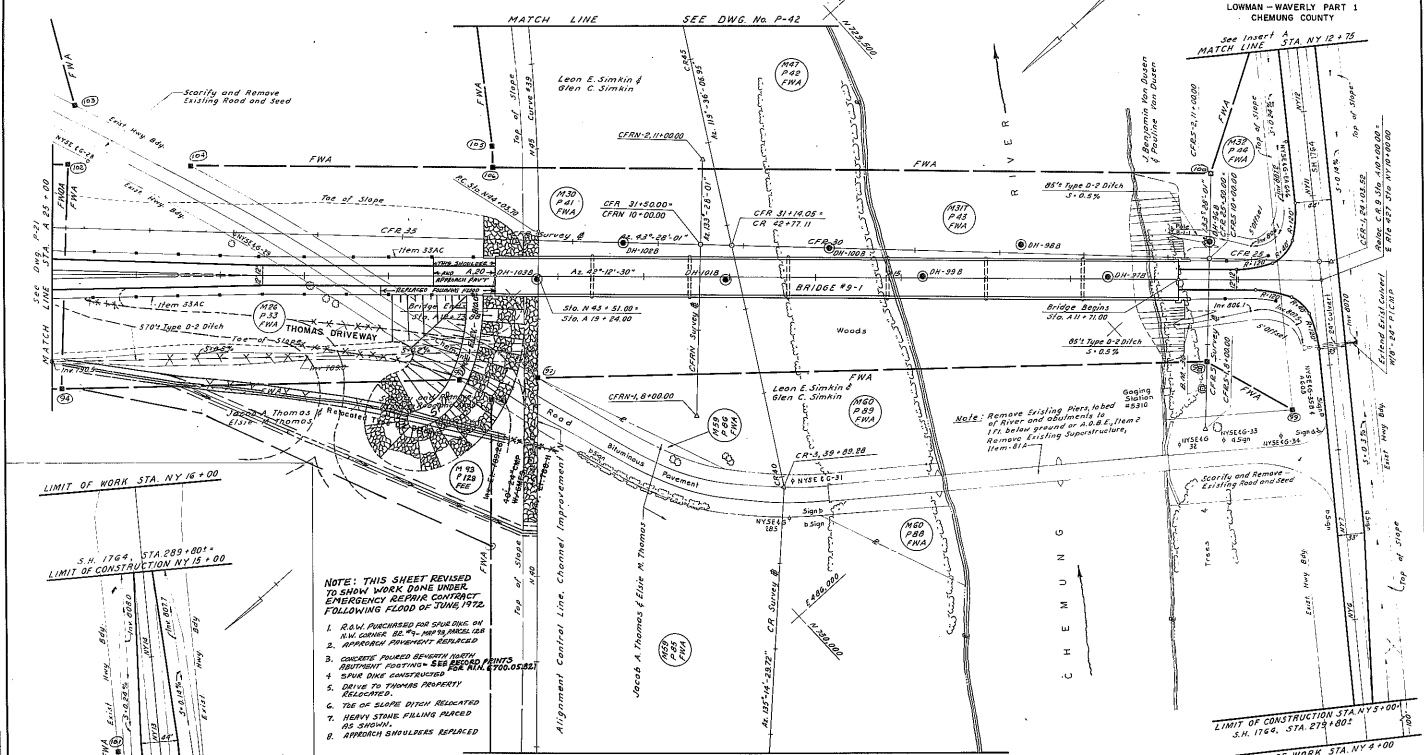
DWG. NO.	SCALE	DATE	GOODKIND & ODEA CONSULTING ENGINEERS
P-32	1" = 40'	4/19/70	

In Charge: *[Signature]*
 Designer: *[Signature]*
 Checker: *[Signature]*
 Date: 4/19/70

CURVE DATA				COORDINATES			
No	R	Δ	D	T	L	N	E
39	2500'	33°06'50"	5°40'45"	718.508'	1387.271'	129.826'	1066.237'
						1066.237'	1066.237'

FED. ROAD DIST. NO.	STATE	FED. AID PROJ. NO.	FISCAL YEAR	SHEET NO.	TOTAL SHEETS
1	N.Y.	APD 221-C21		71 R 1	199

SOUTHERN TIER EXPRESSWAY SECTION 6R
 LOWMAN - WAVERLY PART 1
 CHEMUNG COUNTY



NOTE: THIS SHEET REVISED TO SHOW WORK DONE UNDER EMERGENCY REPAIR CONTRACT FOLLOWING FLOOD OF JUNE, 1972.

1. R.O.W. PURCHASED FOR SIDE DITCH BY N.W. CORNER SE 7/4, 100' W. BRIDGE 128
2. APPROACH SHOULDER REPLACED
3. CONCRETE PAVED BENCH WITH APPROXIMATE POSTING SEE REVISION PRINTS
4. SIDE DITCH CONSTRUCTED
5. DRIVE TO THOMAS PROPERTY RELOCATED
6. TOP OF SLOPE DITCH RELOCATED
7. HEAVY STONE FILLING PLACED AS SHOWN
8. APPROACH SHOULDER REPLACED

REVISIONS

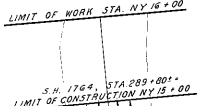
1. R.O.W. MONUMENT NUMERATION
2. GUIDE RAIL (SEE SHEET 28 R 1)
3. REVISION TO TYPE D-2 DITCH LOCATION

ADDITION OF THOMAS DRIVEWAY FROM STA. A19+24 TO STA. A25+00 LT.
 B 40'-24" CMP W/GMES, STA. A 19+24 LT.

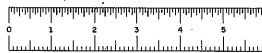
Prepared and recommended
 G. J. ...
 Consulting Engineers

RELOCATED COUNTY ROAD 9
 STAS. A 10+00 TO 25+00
 S.H. 1764, STA. 272+002

DWG. NO.	SCALE	DATE	ENGINEER
P-33	1"=50'	4/1/74	GOODKIND B. O'DEA



INSERT A



F.A.S.T.E. 67-4

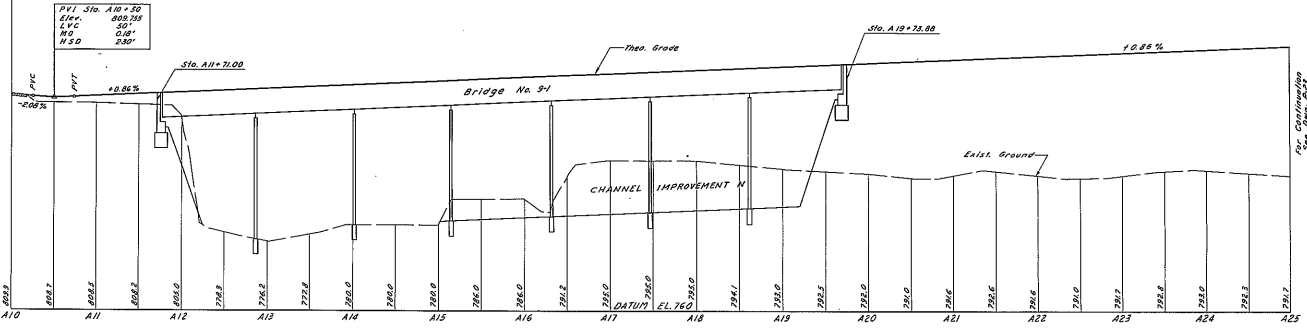
FED. ROAD REG. NO.	STATE	FED. AID PROJ. NO.	FISCAL YEAR	SHEET NO.	TOTAL SHEETS
1	N.Y.	APD 221-(21)		72	200

SOUTHERN TIER EXPRESSWAY SECTION 6R

LOWMAN - WAVERLY PART 1
CHEMUNG COUNTY

Reloc. C.E. 3 Sta. A10+00.00
E Reconstructed Eto. 427 Sta. N170+00.00

Normal Section



RELOCATED COUNTY ROAD 9

In Charge: *[Signature]*
 Checked By: *[Signature]*
 Date: *[Date]*

Prepared and recommended by:
[Signature]
 GOODKIND & O'DEA

Date: *[Date]*
 Consulting Engineers

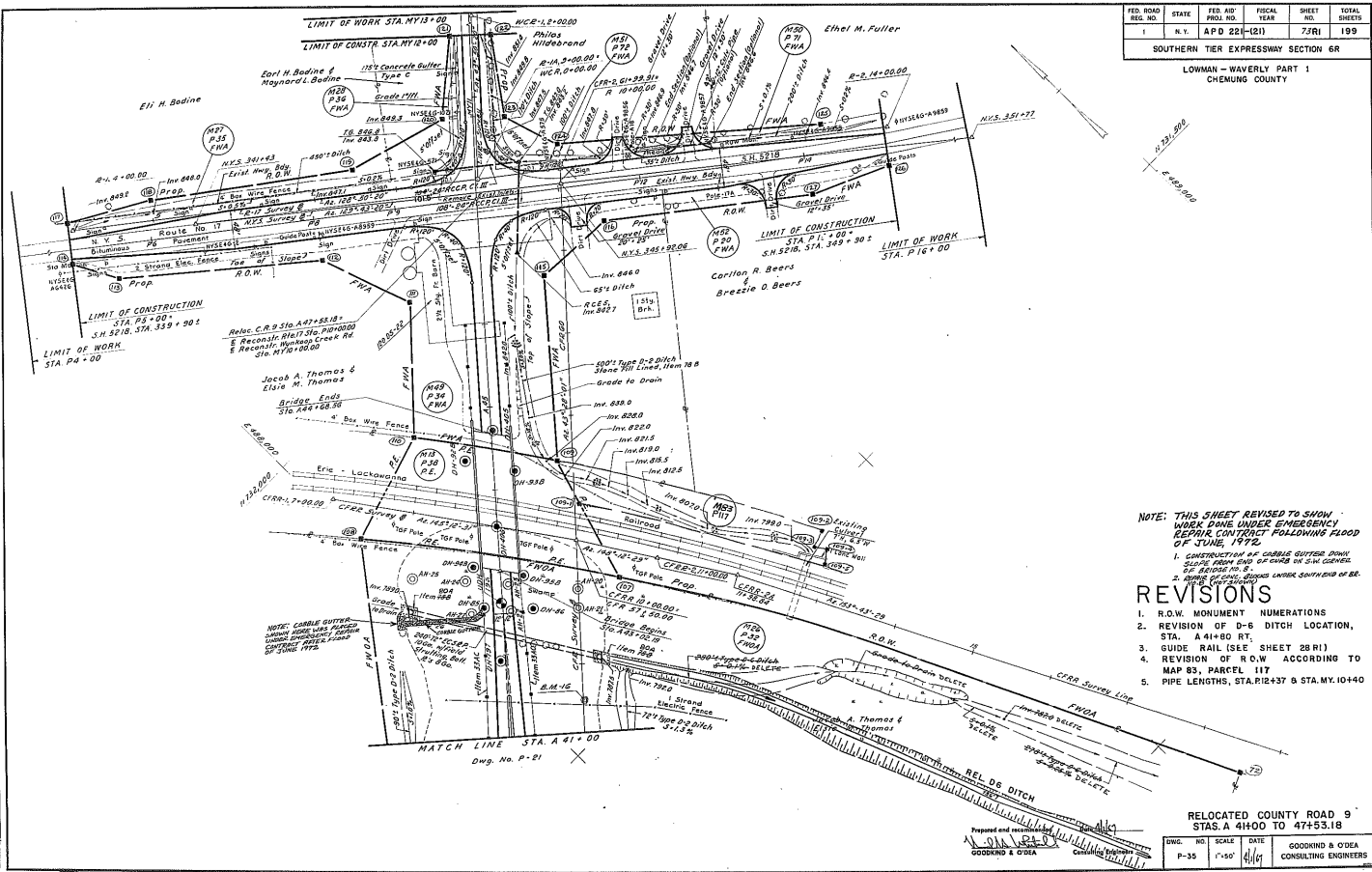
RELOCATED COUNTY ROAD 9
STAS. A 10+00 TO 25+00

DWG. NO.	SCALE	DATE	GOODKIND & O'DEA CONSULTING ENGINEERS
P-34	1" = 50' H. 1" = 10' V.	4/1/69	

FED. ROAD REG. NO.	STATE	FED. AID PROJ. NO.	FISCAL YEAR	SHEET NO.	TOTAL SHEETS
1	N.Y.	APD 221-(21)	73/74	199	

SOUTHERN TIER EXPRESSWAY SECTION 6R

LOWMAN - WAVERLY PART 1
CHEMUNG COUNTY



NOTE: THIS SHEET REVISED TO SHOW WORK DONE UNDER EMERGENCY REPAIR CONTRACT FOLLOWING FLOOD OF JUNE, 1972.

- REVISIONS**
1. CONSTRUCTION OF CABLE GUIDES DOWN SLOPE FROM END OF CURB ON S.W. CORNER OF SECTION 6R.
 2. REPAIR OF CURB, BRIDGE UNDER SWATHING OF RR.
 3. R.O.W. MONUMENT NUMERATIONS
 4. REVISION OF D-6 DITCH LOCATION, STA. A 41+80 RT.
 5. GUIDE RAIL (SEE SHEET 28 R1)
 6. REVISION OF R.O.W. ACCORDING TO MAP 83, PARCEL 117
 7. PIPE LENGTHS, STA. R12+37 & STA. MY.10+40

RELOCATED COUNTY ROAD 9
STAS. A 41+00 TO 47+53.18

DWG. NO.	SCALE	DATE	GOODKIND & O'DEA CONSULTING ENGINEERS
P-35	1"=50'	4/1/74	

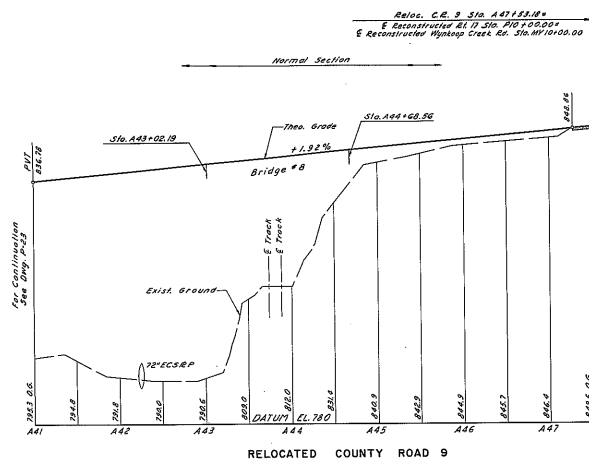
In Charge: [Signature]
 Checked By: [Signature]
 Date: [Date]



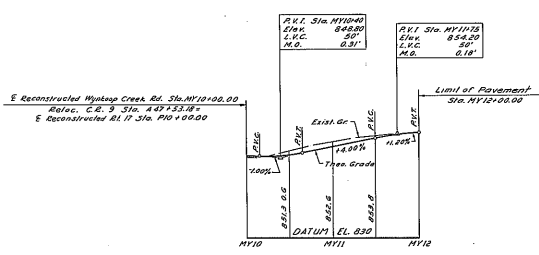
FED. ROAD DIST. NO.	STATE	FED. AID PROJ. NO.	FISCAL YEAR	SHEET NO.	TOTAL SHEETS
1	N.Y.	APD 221 (21)	74	200	

SOUTHERN TIER EXPRESSWAY SECTION 6R

LOWMAN - WAVERLY PART 1
CHEMUNG COUNTY



RELOCATED COUNTY ROAD 9



RECONSTRUCTED WYNKOOP CREEK ROAD

PROFILES

RECONST. WYNKOOP CREEK ROAD
RELOCATED COUNTY ROAD 9
STAS. 44100 TO 47+53.18

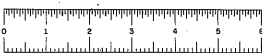
Prepared and recommended by
[Signature]
GOODRIND & ODEA
Consulting Engineers

Date: 4/1/74
Consulting Engineers

DRW.	REV.	SCALE	DATE
P-36		1" = 50' H. 1" = 10' V.	4/1/74

GOODRIND & ODEA
CONSULTING ENGINEERS

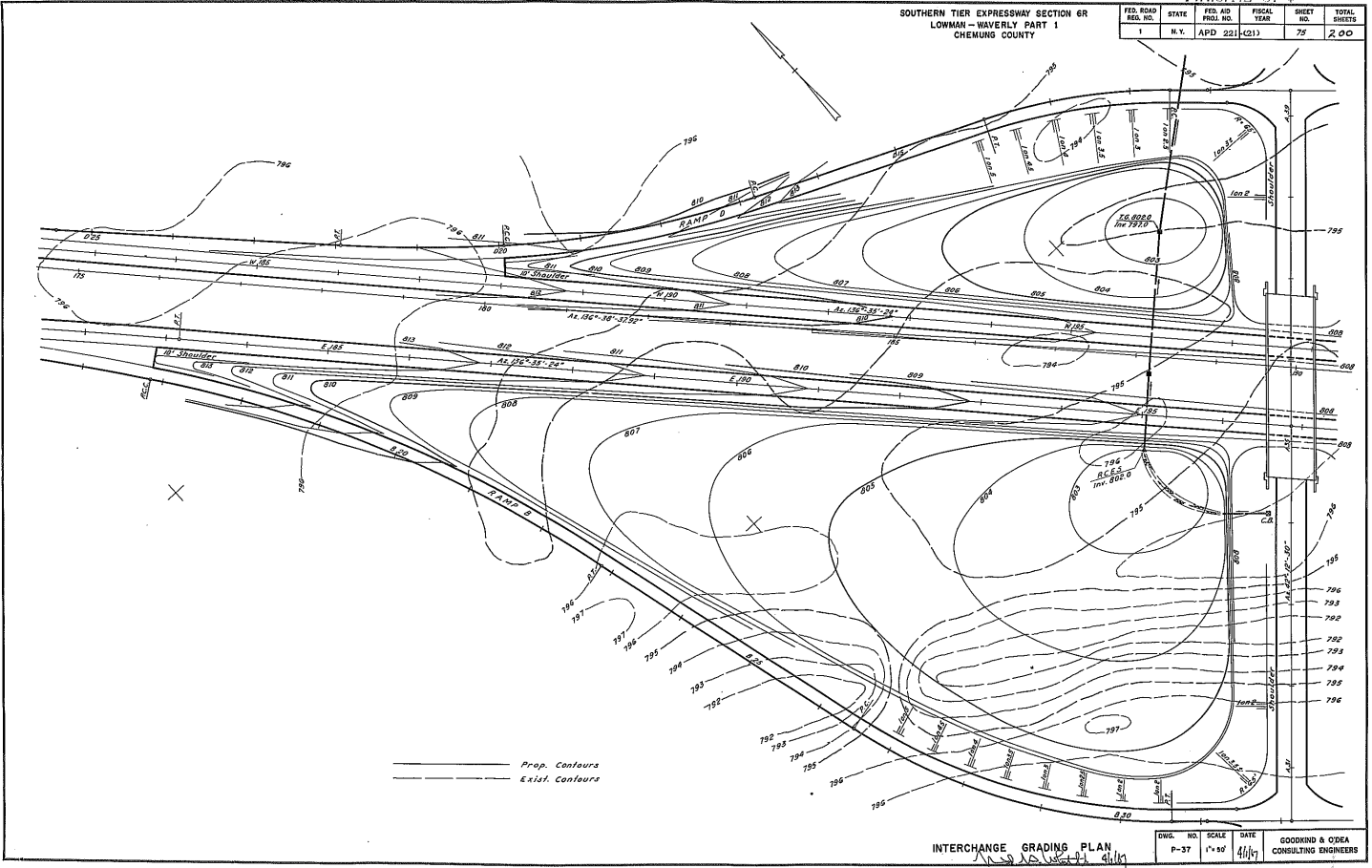
6 Sheets of 67-4
 Checked by: J.L. [Signature]
 Drawn by: J.L. [Signature]



F.A.S.T.E. 67-4

SOUTHERN TIER EXPRESSWAY SECTION 6R
LOWMAN - WAVERLY PART 1
CHEMUNG COUNTY

FED. ROAD REG. NO.	STATE	FED. AID PROJ. NO.	FISCAL YEAR	SHEET NO.	TOTAL SHEETS
1	N.Y.	APD 221-(21)	75	200	



Prop. Contours
Exist. Contours

INTERCHANGE GRADING PLAN
N.S. LAURETTI 4/1/77

DWG. NO.	SCALE	DATE	GOODKIND & ODEA CONSULTING ENGINEERS
P-37	1"=40'	4/1/77	

Checked by: J.S.C.
Designed by: J.S.C.
Drawn by: J.S.C.

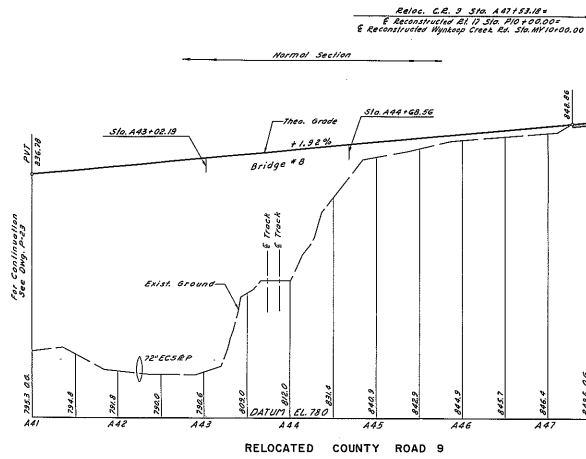


F.A.S.T.E 67-4

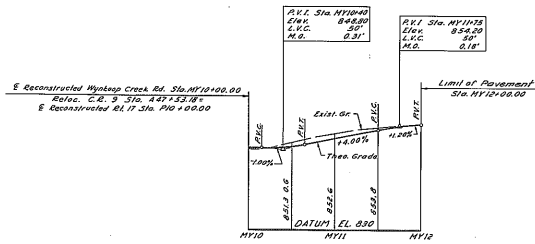
FED. ROAD DIST. NO.	STATE	FED. AID PROJ. NO.	FISCAL YEAR	SHEET NO.	TOTAL SHEETS
1	N.Y.	APD 321 (S1)	74	200	

SOUTHERN TIEN EXPRESSWAY SECTION 6R

LOWMAN - WAVERLY PART 1
CHEMUNG COUNTY



RELOCATED COUNTY ROAD 9



RECONSTRUCTED WYNKOOP CREEK ROAD

PROFILES

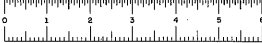
RECONST. WYNKOOP CREEK ROAD
RELOCATED COUNTY ROAD 9
STAS. A 4100 TO 47+53.18

Prepared and recommended by
[Signature]
GOODKIND & O'DEA

Date: 4/1/74
Consulting Engineers

DWG. NO.	SCALE	DATE	GOODKIND & O'DEA CONSULTING ENGINEERS
P-36	1" = 50' H 1" = 100' V	4/1/74	

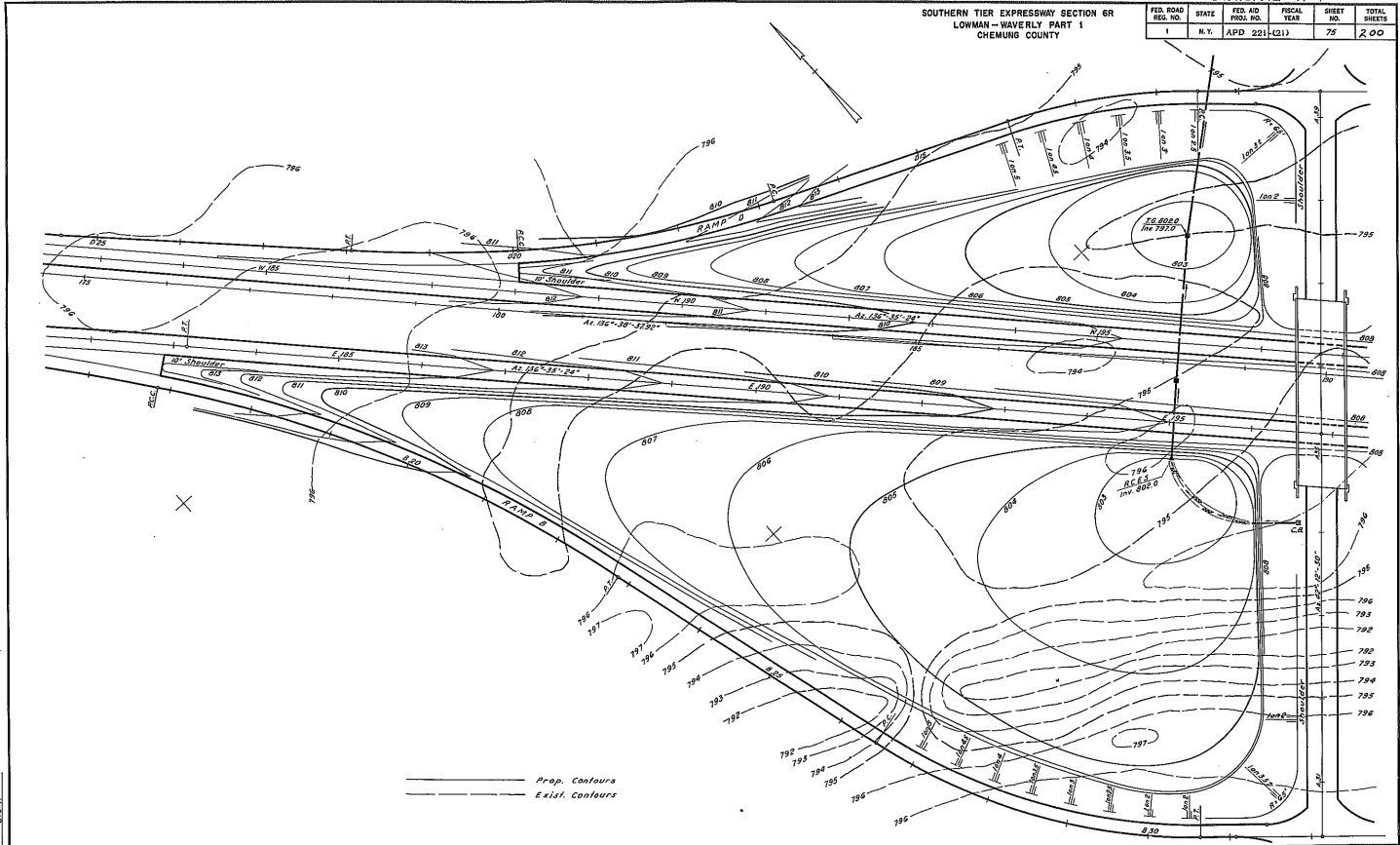
All Rights Reserved
 No Part of This Document
 May Be Reproduced or
 Transmitted in Any Form
 or by Any Means
 Without the Written
 Consent of the
 Copyright Owner



F.A.S.T.E 67-4

SOUTHERN TIER EXPRESSWAY SECTION 6R
LOWMAN-WAVERLY PART 1
CHEMUNG COUNTY

FED. ROAD DIST. NO.	STATE	FED. AID PROJ. NO.	FISCAL YEAR	SHEET NO.	TOTAL SHEETS
1	N.Y.	APD 221-(21)	75	200	



Prop. Contours
Exist. Contours

INTERCHANGE GRADING PLAN
AS NOTED

DWG. NO.	SCALE	DATE	GOODKIND & O'DEA CONSULTING ENGINEERS
P-37	1"=50'	4/1/77	

Checked by: S.C.V.
Designed by: S.C.V.
Drawn by: S.C.V.

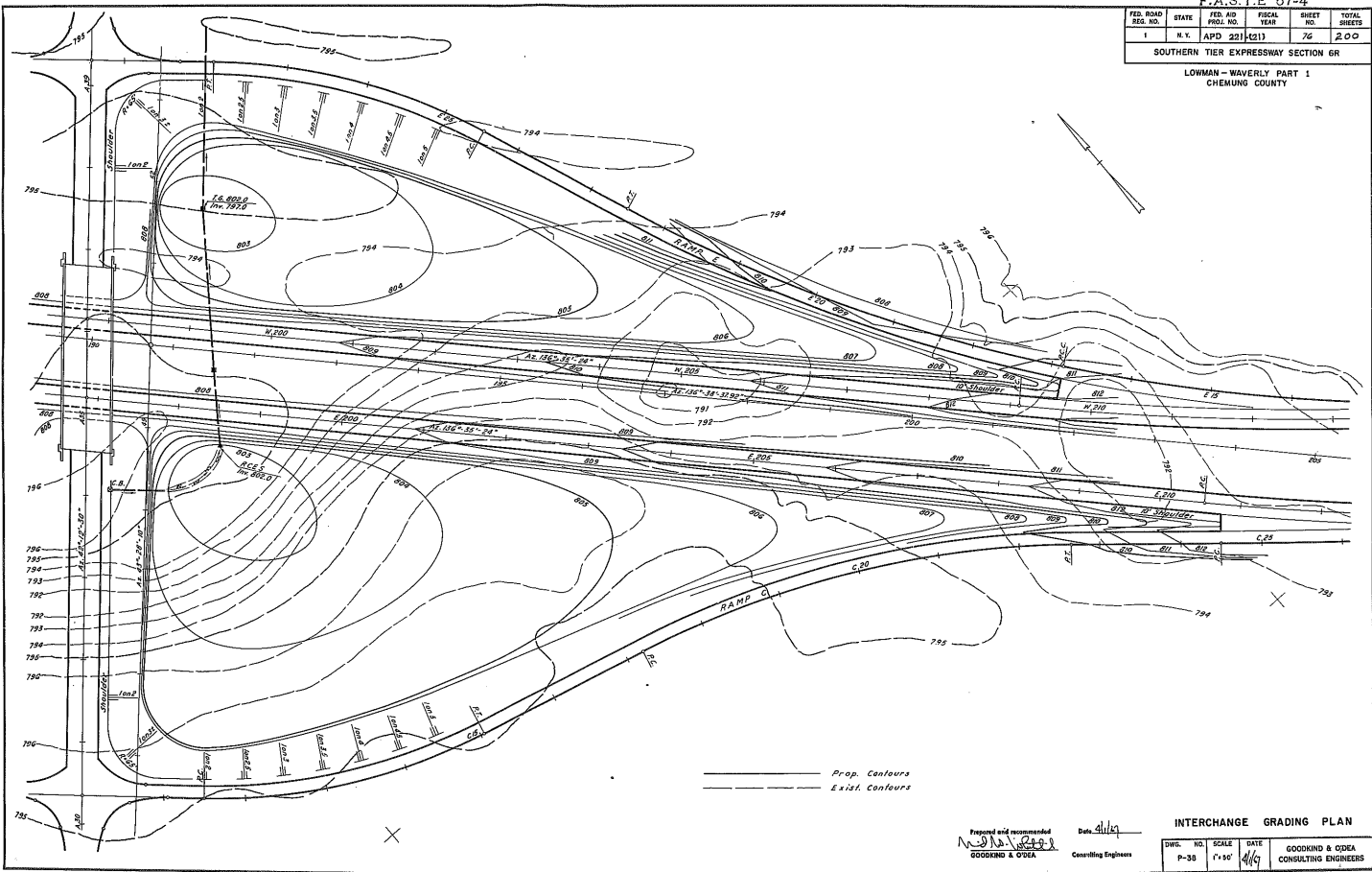


F.A.S.T.E 67-4

FED. ROAD DIST. NO.	STATE	FED. AID PROJ. NO.	FISCAL YEAR	SHEET NO.	TOTAL SHEETS
1	N.Y.	APD 221(021)	74	200	

SOUTHERN TIER EXPRESSWAY SECTION 6R

LOWMAN - WAVERLY PART 1
CHEMUNG COUNTY



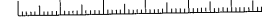
In Charge: A. J. O'Dea
 Checked By: A. J. O'Dea
 Date: 11/19/74

———— Prop. Contours
 - - - - - Exist. Contours

Prepared and recommended
M. J. O'Dea
 GOODKIND & O'DEA

Date: 11/19/74
 Consulting Engineers

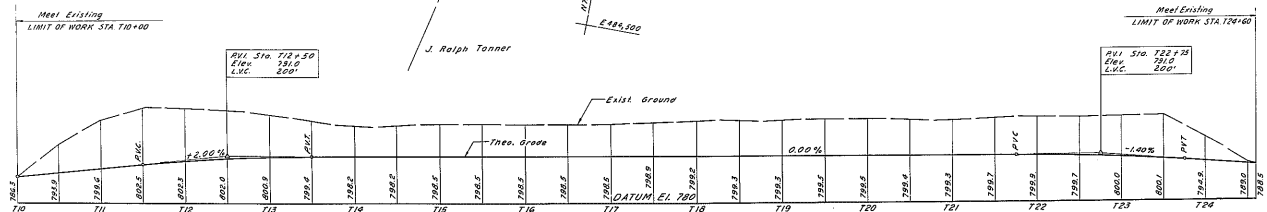
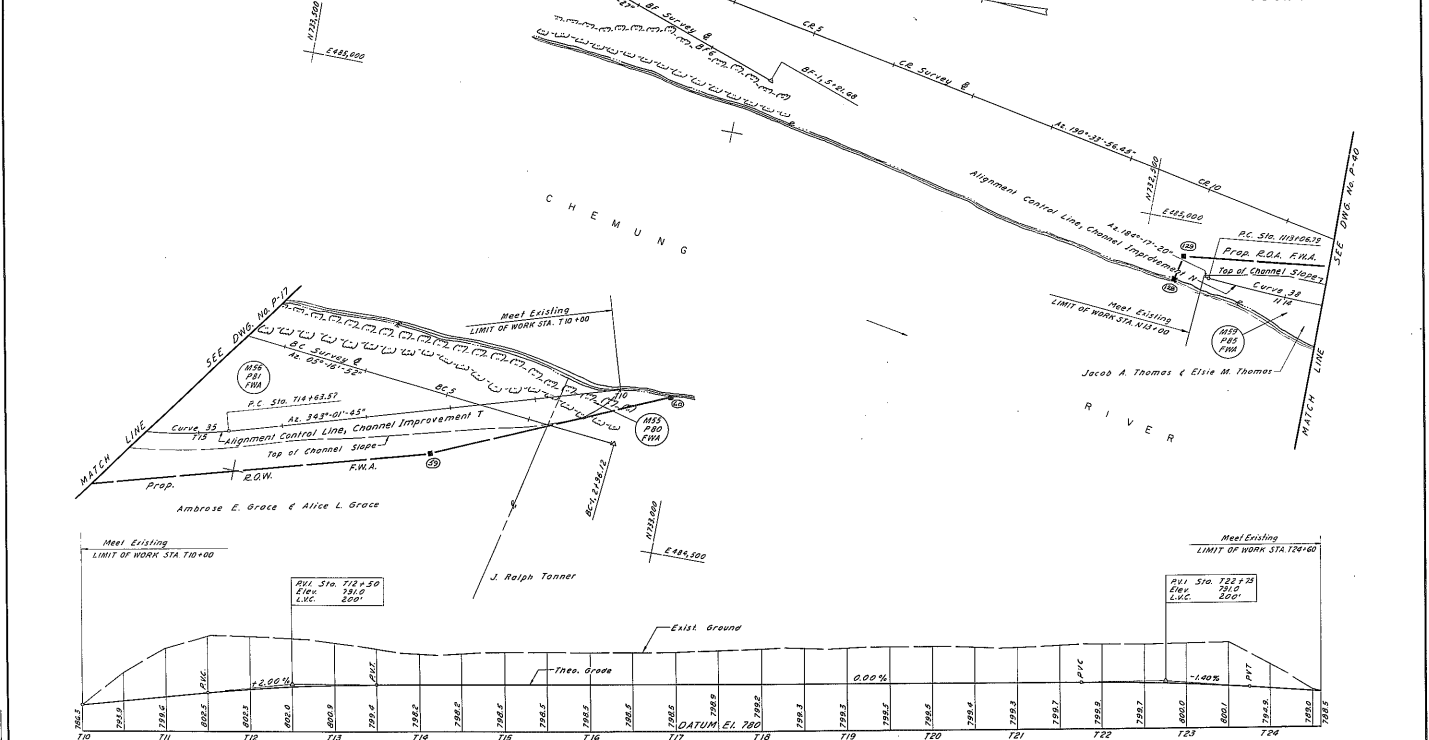
INTERCHANGE GRADING PLAN
 DWG. NO. | SCALE | DATE | GOODKIND & O'DEA
 P-38 | 1"=50' | 11/19/74 | CONSULTING ENGINEERS



CURVE DATA					COORDINATES				
No.	R	Δ	D	T	L	N	E	N	E
33	300.00'	24°-17'-00"	11°-00'-33"	116.430'	228.783'	733.573	882.544	671.772	839.426
34	1,000.00'	52°-04'-50"	2°-51'-53.24"	377.204'	1877.554'	1932.416	2294.484	2319.230	2822.238

FED. ROAD REC. NO.	STATE	FED. AID PROJ. NO.	FISCAL YEAR	SHEET NO.	TOTAL SHEETS
1	N.Y.			77RI	199

SOUTHERN TIER EXPRESSWAY SECTION 6R
LOWMAN - WAVERLY PART 1
CHEMUNG COUNTY



REVISIONS

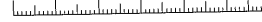
I. R.O.W. MONUMENT NUMERATION

Prepared and recommended
[Signature]
GOODKIND & O'DEA
Consulting Engineers

Date: 4/1/67
Consulting Engineers

CHANNEL IMPROVEMENTS N & T
DWG. NO. SCALE DATE
P-39 1" = 50' 4/1/67
GOODKIND & O'DEA
CONSULTING ENGINEERS

In Charge: *[Signature]*
 Drawn By: *[Signature]*
 Checked By: *[Signature]*

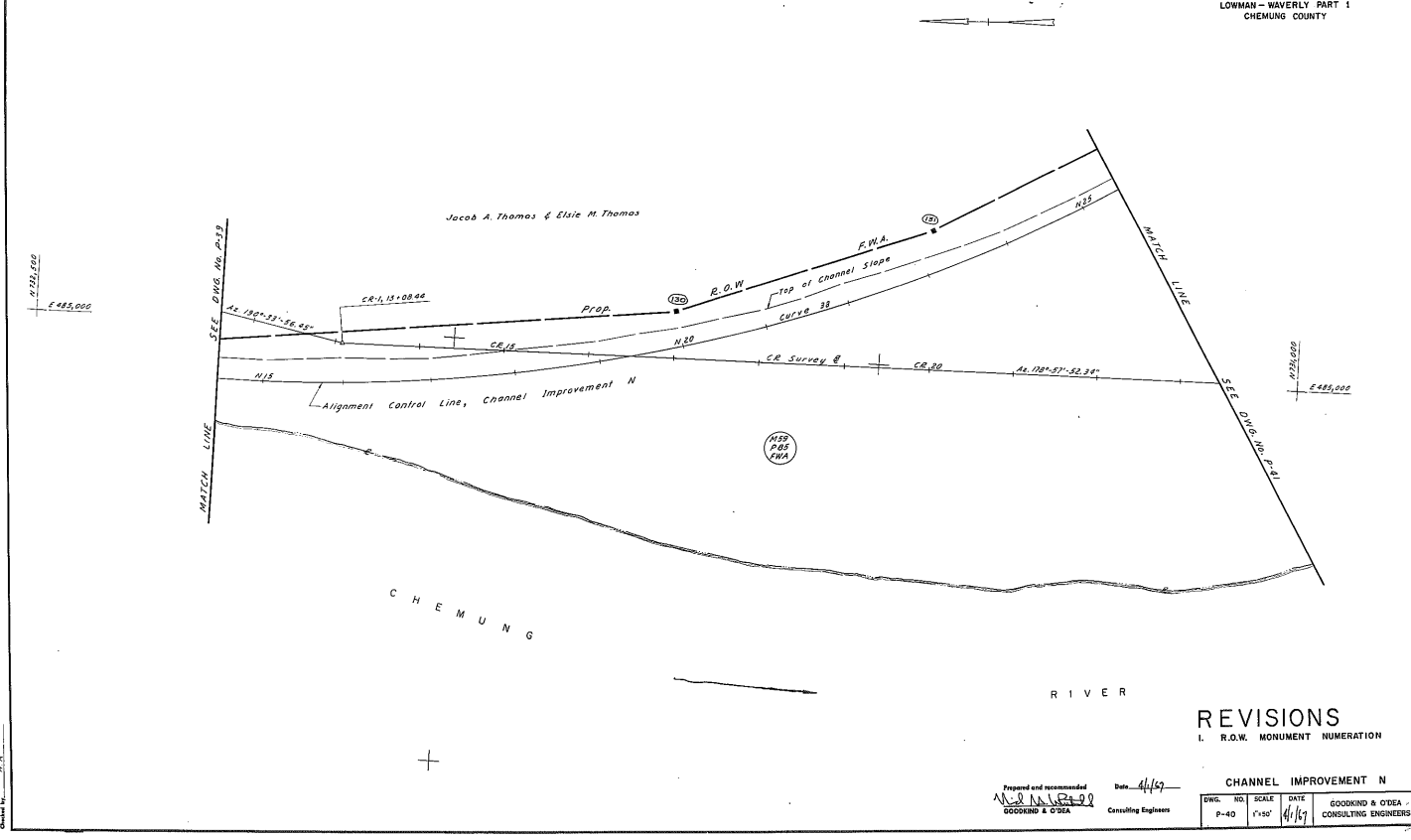


CURVE DATA						COORDINATES					
No	R	Δ	D	T	L	N	E	N	E		
1	1000.00	90°	100.00	100.00	100.00	100.00	100.00	100.00	100.00		

FED. ROAD REG. NO.	STATE	FED. AID PROJ. NO.	FISCAL YEAR	SHEET NO.	TOTAL SHEETS
1	N.Y.			74 R1	199

SOUTHERN TIER EXPRESSWAY SECTION 6R

LOWMAN - WAVERLY PART 1
CHEMUNG COUNTY



REVISIONS
I. R.O.W. MONUMENT NUMERATION

Prepared and recommended
[Signature]
GOODKIND & O'DEA
Consulting Engineers

Date: 4/1/59

DWG. NO.	SCALE	DATE	GOODKIND & O'DEA CONSULTING ENGINEERS
P-40	1"=50'	4/1/59	

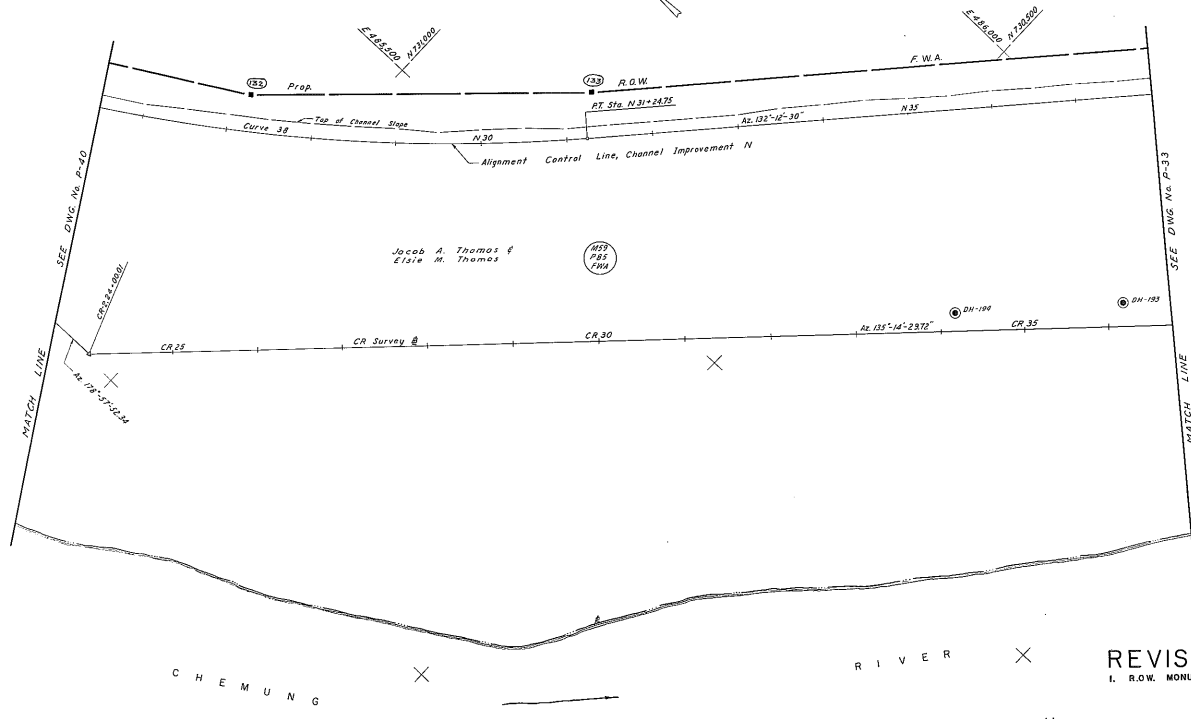
Made by: A.M.F. 11/58
 Checked by: J.P. 11/58
 Date: 11/58

CURVE DATA					COORDINATES				
No.	R	Δ	D	T	L	N	E	N	E
38	10000.00	52°-04'-30"	2°-57'-52.24"	972.806	1,817.954	121,406.724	104,313.112	170,182.277	143,518.274

FED. ROAD DIST. NO.	STATE	FED. AID PROJ. NO.	FISCAL YEAR	SHEET NO.	TOTAL SHEETS
1	N. Y.			79 RI	189

SOUTHERN TIER EXPRESSWAY SECTION 6R

LOWMAN - WAVERLY PART 1
CHEMUNG COUNTY



Jacob A. Thomas &
Elsie M. Thomas

(193)
P. 85
196

REVISIONS
I. R.O.W. MONUMENT NUMERATION

Prepared and recommended
[Signature]
GOODKIND & O'DEA
Consulting Engineers

Date: 4/1/67

CHANNEL IMPROVEMENT N
DWG. NO. P-41 SCALE 1"=50' DATE 4/1/67 GOODKIND & O'DEA CONSULTING ENGINEERS

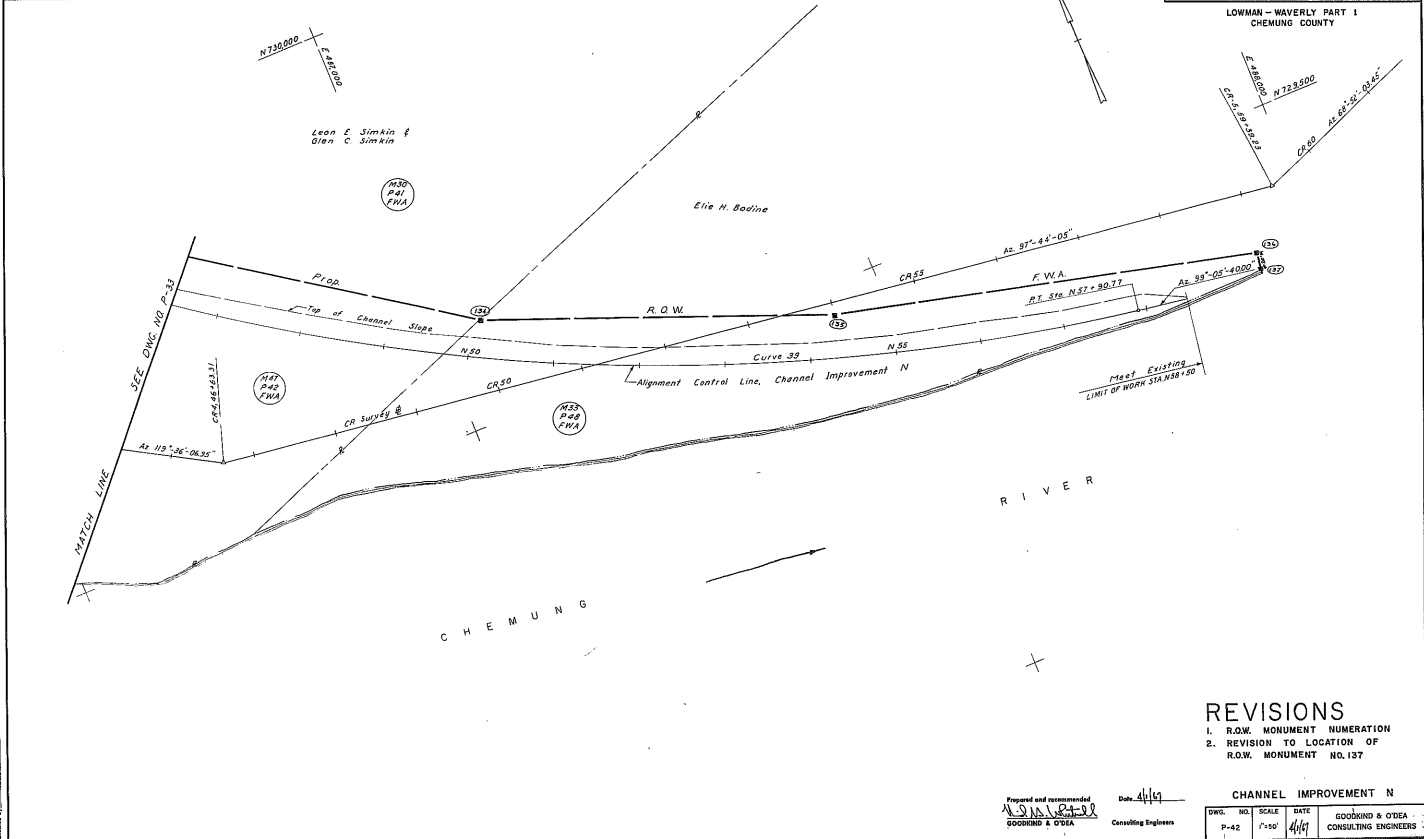
As Checked by: *[Signature]*
 Made by: *[Signature]*
 Checked by: *[Signature]*

CURVE DATA					COORDINATES				
No.	R	Δ	D	T	L	N	E	N	E
						P.C.	P.T.	P.C.	P.T.
33	2400'	31° 06' 30"	2° 23' 43.37"	718.508'	1387.07'	109.806.27'	146.537.10'	128.346.77'	147.228.340'

FED. ROAD REG. NO.	STATE	FED. AID PROJ. NO.	FISCAL YEAR	SHEET NO.	TOTAL SHEETS
1	N.Y.			308 R1	199

SOUTHERN TIER EXPRESSWAY SECTION 6R

LOWMAN - WAVERLY PART 1
CHEMUNG COUNTY



- REVISIONS**
- R.O.W. MONUMENT NUMERATION
 - REVISION TO LOCATION OF R.O.W. MONUMENT NO. 137

Prepared and recommended by: *[Signature]*
GOODKIND & O'DEA
Consulting Engineers

Date: 4/1/79

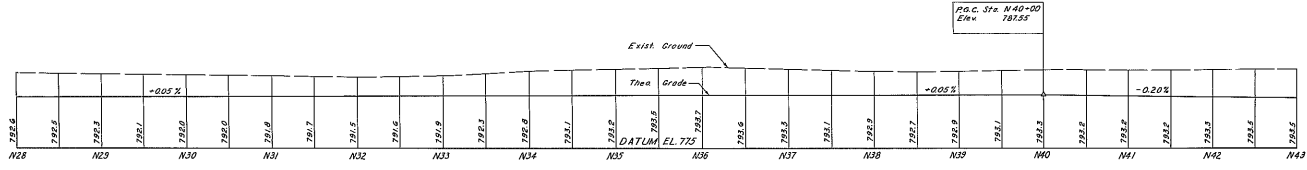
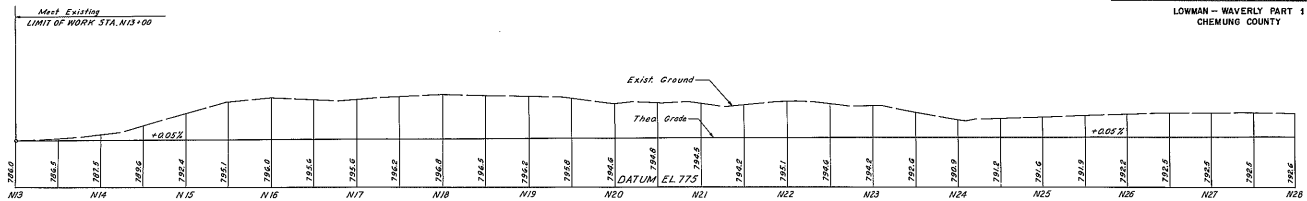
CHANNEL IMPROVEMENT N			
DWG. NO.	SCALE	DATE	GOODKIND & O'DEA CONSULTING ENGINEERS
P-42	1"=50'	4/1/79	

In Charge: *[Signature]*
 Checked by: *[Signature]*
 Date: *[Signature]*

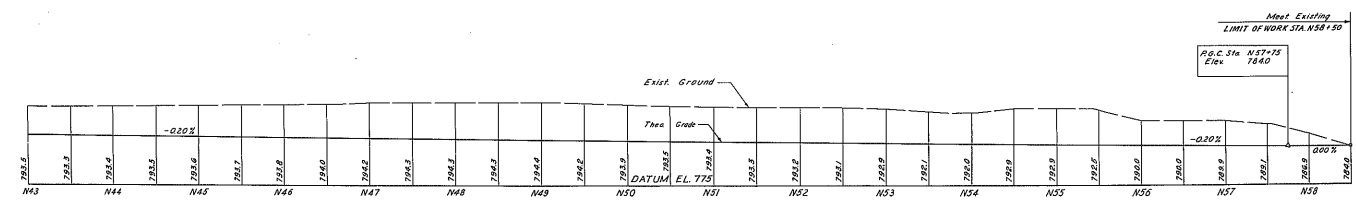


FED. ROAD DIST. NO.	STATE	FED. AID PROJ. NO.	FISCAL YEAR	SHEET NO.	TOTAL SHEETS
1	N.Y.	APD 221-(21)	01	200	200

SOUTHERN TIER EXPRESSWAY SECTION 6R
LOWMAN - WAVERLY PART 1
CHEMUNG COUNTY



P.C. Sta N40+00
Elev. 781.55



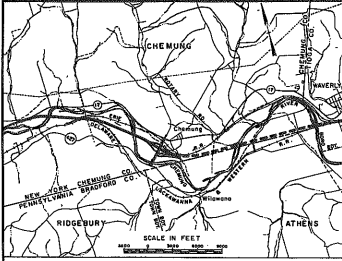
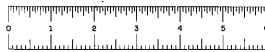
P.C. Sta N57+75
Elev. 784.0

As Shown on
Sheet No.
Checked by
Date

Prepared and recommended
ALL-D
GOODKIND & O'DEA
Consulting Engineers

Date 4/1/67

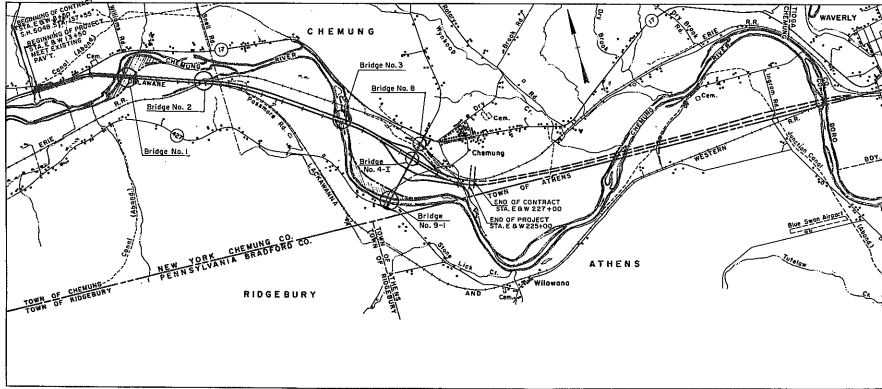
CHANNEL IMPROVEMENT N
DWG. NO. 1
SCALE 1"=10'
DATE 4/1/67
GOODKIND & O'DEA
CONSULTING ENGINEERS



LOCATION MAP

FED. ROAD REG. NO.	STATE	FED. AID PROG. NO.	SHEET NO.	TOTAL SHEETS
1	N.Y.	AFD-221(21)	22	200

SOUTHERN TIER EXPRESSWAY SECTION 6R
LOWMAN - WAVERLY PART I
CHEMUNG COUNTY



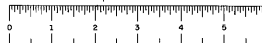
BRIDGE LOCATION PLAN

BRIDGE LOCATION PLAN

Prepared and recommended
W. J. O'Dea
GOODKING & O'DEA
Consulting Engineers

Date *4/1/47*

DWG. NO.	SCALE	DATE	GOODKING & O'DEA CONSULTING ENGINEERS
3-1	As Shown	4/1/47	



FED. ROAD DIST. NO.	STATE	FEDERAL AID PROJECT NO.	SHEET NO.	TOTAL SHEETS
1	N.Y.	APD-221C13	59	200

SOUTHERN TIER EXPRESSWAY SECTION 6R
LOWMAN - WAVERLY PART I
CHEMUNG COUNTY

GENERAL NOTES

Design Specifications: AASHTO 1961 modified and current American Welding Society modified. The stresses assumed for design purposes conform to 1961 AASHTO Specifications with the 28-day concrete stress (f_c) = 3000 psi minimum.

Bridges 41, 4 and 5: L.L. MS30-44 or two 24,000 lb. axle spaced 4'0" on centers.

Material and Construction Specifications: Specifications of N.Y.S. Department of Public Works dated January 3, 1963 with current additions and modifications.

The Contractor's attention is directed to the Special Notes for this structure which appear in the proposal. Particular attention should be given to the Foundation notes which briefly outline the anticipated subsurface conditions at the site of the structure and which specify certain requirements relative to construction.

The cost of furnishing and placing water used for setting and selected gravel fill will be paid for under Item 10 and 10M of the highway portion of the contract.

Reinforcing bars shall be lapped a minimum of 30 diameters.

The minimum cover for reinforcement shall be as follows:

Top bars in non-slab deck slab	1 1/2"
Bottom bars in non-slab deck slab	1 1/2"
Top bars in safety walks	1 1/2"
Partings	3"
All others	2"

All exposed edges of concrete are to be chamfered 1" unless shown otherwise on the plans.

The cost of all joint material will be included in the price bid for the various items of the contract.

All concrete anchor studs which are attached to the various steel details shall meet the requirements listed in paragraph 3, Construction Details, of Item 8B - Stud Sheet Connectors. Payment for furnishing and placing the concrete anchors will be included in the unit price bid for the item to which the anchors are attached.

Concrete Items and Comment:

Description	Item No.	Type of Comment
Pier columns and cap beams, superstructure and substructure safety walks, abutment bascule	18	2
Non-slab deck slabs	18M	2
Abutments, wingwalls, solid piers, all footings	20	2
Cast-in-Place Concrete Piles	85C	2

All concrete shall have entrained air in accordance with the specifications.

SUPERSTRUCTURE NOTES

After all superstructure steel has been erected, elevations shall be taken on the top of the steel at the centerline of web at each centerline of bearing, center of the span and at other locations where theoretical bottom of the slab elevations are indicated on the plans. The depth of haunch required to position the slab forces is obtained as follows: From the measured top of steel elevations subtract the deflections due to slab and superimposed dead load. Subtract this result from the listed bottom of slab elevation.

All bearings are to be field welded to base or girders.

If the Contractor elects to use corrugated metal form for the structural slab the details of these forms shall be submitted to the Deputy Chief Engineer (Design) for approval, prior to their use. The Contractor's attention is directed to additional notes appearing in the contract documents relative to corrugated metal form.

All intermediate stiffeners and/or connection plates used in pairs shall be welded to the web and be placed point tight against both flanges. This may be accomplished by cutting the stiffeners to fit or by cutting the stiffeners 1/8-inch short and then placing the stiffener tightly against the tension flange and welding the opposite end to the compression flange. Fitted stiffeners shall not be driven in place with sufficient force to distort the flange, web or stiffener.

All intermediate stiffeners used singly shall be placed point tight against the tension flange under dead load and welded to the web and compression flange under dead load.

When the particular type of well joint preparation is not shown on the plans by symbol or otherwise, any joint considered prequalified by Paragraph 215 of the A.W.C. Specification IS-0-68 may be used except that backing strips or plates, when used, shall be removed after welding and the joint ground smooth, unless otherwise specified. When the prequalified joints used placed a limit on the maximum thickness of plates joined; this thickness shall always refer to the thickness of material at the edge of the heat affect zone of the thicker plate.

The ends of all girders and beams and the bearing stiffeners shall be vertical. All intermediate transverse stiffeners shall be vertical unless otherwise approved by the Deputy Chief Engineer (Design).

All anchor bolts shall be galvanized in accordance with the requirements of material Specification 810.

Lined Oil Protective Coating, Item 6641C, to be applied to deck slab between curbs.

SUPERSTRUCTURE CONSTRUCTION PROCEDURES

1. Erect stringers, intermediate and end diaphragms.
2. Set railing anchor bolts by template.
3. After the superstructure steel has been erected, elevations shall be taken along the beams to provide information for adjustment of haunches to put the concrete slab in proper grade.
4. Form slab. The lateral working surface shall be finished as specified in Section 7, Structural Concrete, under heading "Finishing Integral Bearing Surfaces on Bridge Slabs" New York State Department of Public Works Specifications.
5. Place lower nuts on upper ends of railing anchor bolts.
6. Place railing on lower nuts and adjust to bring railing into line and grade.
7. Place upper nuts on anchor bolts and tighten down on plate.
8. Set granite curb to line and grade.
9. Four safety walk to proper line and grade.

SUBSTRUCTURE NOTES

All end, topsoil and excavatable material under the substructure substructure shall be removed as specified under the General Excavation Specifications and replaced by the same item as the layer of substructure adjacent and above as shown on the plans.

All substructure of Selected Pile, Item 82P-B and Selected Pile (Bridge Foundation) Item 82P-C, shall be computed to a minimum dry density of 100% of maximum density as defined under "Substructure" of the General Excavation Specifications. However, where piles are to be placed through the substructure, a minimum dry density of 90% of the Maximum Density will be required.

The Contractor shall place and compact all fill for bridges between the final west of slope in accordance with the plans and specifications in a manner satisfactory to the Deputy Chief Engineer (Design). The substructure shall be allowed to stand for a period of time satisfactory to the Deputy Chief Engineer (Design) prior to any substructure construction.

Items 2 and 2P-B and Items 2 and 2P-C shall be placed simultaneously, in contact, on both sides of the vertical support line. Shoring or other means shall not be used to separate the two materials.

The installation of Selected Pile, Item 82P-B, as shown on the structural plans, shall be completed immediately following the completion of abutments or walls.

For design foundation pressure, pile loads, estimated pile lengths and selected In-situ Test piles and respective Foundation Drawing.

Bituminous Material, Item 41, shall be applied to the backs of all abutments and wingwalls above top of footing, where fill is in contact with the walls.

Epoxy Protective Coating for Concrete shall be applied to the following surfaces:

Abutments - All exposed pedestal surfaces, bridge seats, including the area under the bearings, exposed vertical surfaces of abutment and curbside walls facing the superstructure.

Piers - All pedestal surfaces including the area under the bearings, and the top surface of pier between pedestals including the edge chamfer at top edge of pier column.

In Charge <i>L. Hollen</i>	Date	Revision
Checked by		
Design Checked by <i>L. Hollen</i>		
Detail Checked by <i>L. Hollen</i>		

Prepared and presented by *Goodkind & O'Dea*
Checked by *Goodkind & O'Dea*

Date *4/1/69*
Consulting Engineer

BRIDGE NOTES

DWG. NO.	SCALE	DATE	GOODKIND & O'DEA CONSULTING ENGINEERS
5-3		4/1/69	

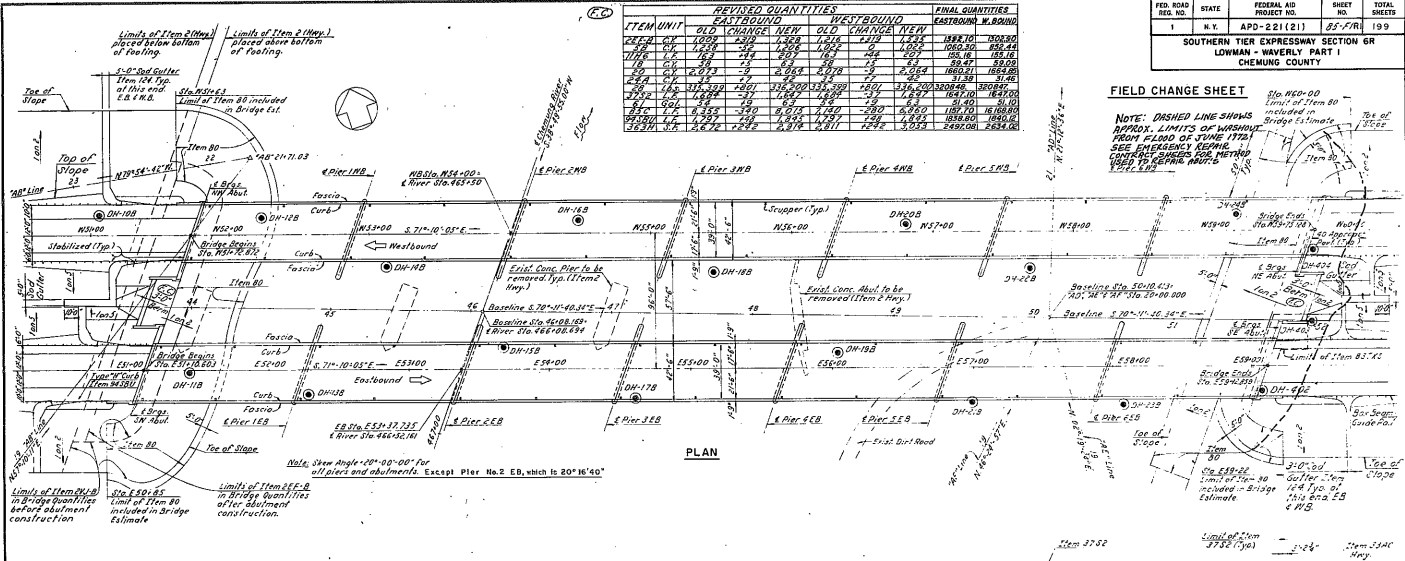
FED. ROAD DIST. NO.	STATE	FEDERAL AID PROJECT NO.	SHEET NO.	TOTAL SHEETS
1	N.Y.	APD-221(21)	25-77R	199

SOUTHERN TIER EXPRESSWAY SECTION 6R
LOWMAN - WAVERLY PART I
CHEMUNG COUNTY

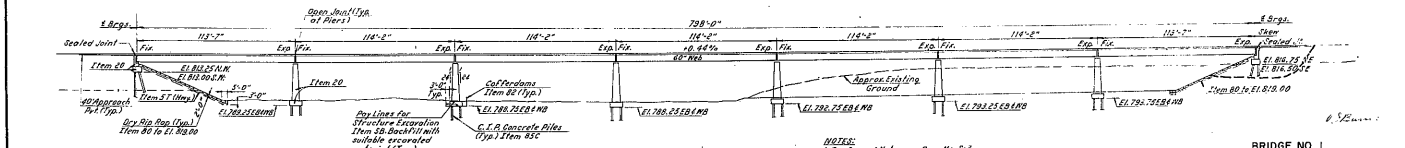
ITEM	UNIT	REVISED QUANTITIES			FINAL QUANTITIES		
		ESTIMATED	CHANGE	NEW	ESTIMATED	CHANGE	NEW
100	cu yd	1,000	-200	800	1,000	-200	800
101	sq yd	100	-20	80	100	-20	80
102	cu yd	500	-100	400	500	-100	400
103	sq yd	200	-40	160	200	-40	160
104	cu yd	300	-60	240	300	-60	240
105	sq yd	150	-30	120	150	-30	120
106	cu yd	400	-80	320	400	-80	320
107	sq yd	250	-50	200	250	-50	200
108	cu yd	100	-20	80	100	-20	80
109	sq yd	120	-24	96	120	-24	96
110	cu yd	200	-40	160	200	-40	160
111	sq yd	180	-36	144	180	-36	144
112	cu yd	300	-60	240	300	-60	240
113	sq yd	250	-50	200	250	-50	200
114	cu yd	150	-30	120	150	-30	120
115	sq yd	100	-20	80	100	-20	80
116	cu yd	80	-16	64	80	-16	64
117	sq yd	70	-14	56	70	-14	56
118	cu yd	60	-12	48	60	-12	48
119	sq yd	50	-10	40	50	-10	40
120	cu yd	40	-8	32	40	-8	32
121	sq yd	30	-6	24	30	-6	24
122	cu yd	20	-4	16	20	-4	16
123	sq yd	15	-3	12	15	-3	12
124	cu yd	10	-2	8	10	-2	8
125	sq yd	8	-1.6	6.4	8	-1.6	6.4
126	cu yd	6	-1.2	4.8	6	-1.2	4.8
127	sq yd	5	-1	4	5	-1	4
128	cu yd	4	-0.8	3.2	4	-0.8	3.2
129	sq yd	3	-0.6	2.4	3	-0.6	2.4
130	cu yd	2	-0.4	1.6	2	-0.4	1.6
131	sq yd	1.5	-0.3	1.2	1.5	-0.3	1.2
132	cu yd	1	-0.2	0.8	1	-0.2	0.8
133	sq yd	0.8	-0.16	0.64	0.8	-0.16	0.64
134	cu yd	0.6	-0.12	0.48	0.6	-0.12	0.48
135	sq yd	0.5	-0.1	0.4	0.5	-0.1	0.4
136	cu yd	0.4	-0.08	0.32	0.4	-0.08	0.32
137	sq yd	0.3	-0.06	0.24	0.3	-0.06	0.24
138	cu yd	0.2	-0.04	0.16	0.2	-0.04	0.16
139	sq yd	0.15	-0.03	0.12	0.15	-0.03	0.12
140	cu yd	0.1	-0.02	0.08	0.1	-0.02	0.08

FIELD CHANGE SHEET

NOTE: DASHED LINE SHOWS APPROX. LIMITS OF WASHING FROM FLOOD OF JUNE 1978. SEE EMERGENCY DESIGN CONTRACT SHEETS FOR METHOD USED TO ESTIMATE.



ELEVATION



REVISIONS

1. SKEW ANGLE ON PIER No. 2 EB.
2. ADDITION OF FINAL QUANTITIES TO TABLE OF REVISED ONES

LONGITUDINAL SECTION (ALONG E. EASTBOUND)

Date	Revision
10/15/78	1. SKEW ANGLE ON PIER No. 2 EB.
10/15/78	2. ADDITION OF FINAL QUANTITIES TO TABLE OF REVISED ONES

In Charge of E. G. Sullivan
Designed by J. G. Sullivan
Design Checked by J. G. Sullivan
Checked by J. G. Sullivan
Small Checked by J. G. Sullivan

NOTES:
1. For General Notes, see Div. No. 3-3
2. For Location Plan, see Div. No. 3-1
3. For Layout Plan, see Div. No. 3
4. For Payment Details of Abutments, see Div. No. 3

BRIDGE No. 1
EXPRESSWAY OVER CHEMUNG RIVER
GENERAL PLAN AND ELEVATION

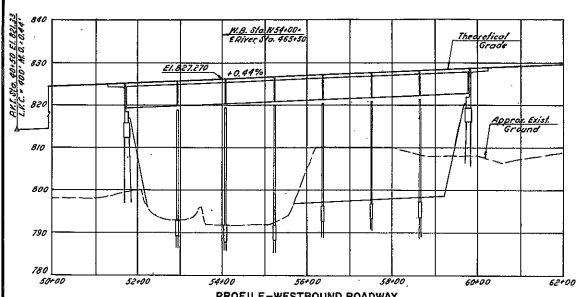
Prepared and recommended by
GODDARD & O'DEA
Consulting Engineers

DWG. NO.	SCALE	DATE	GODDARD & O'DEA CONSULTING ENGINEERS
1 of 16	1"=30'	10/16/78	F.A.S.I.E. 67-4

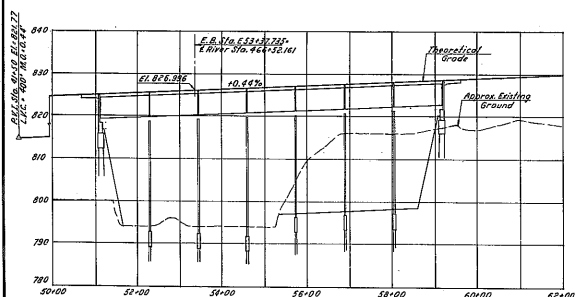


FED. ROAD DIST. NO.	STATE	FEDERAL AID PROJECT NO.	SHEET NO.	TOTAL SHEETS
1	R.C.	APD-221017	06	200

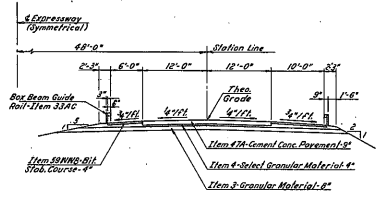
SOUTHERN TIER EXPRESSWAY SECTION BR
LOWMAN - WAVERLY PART I
CHEMUNG COUNTY



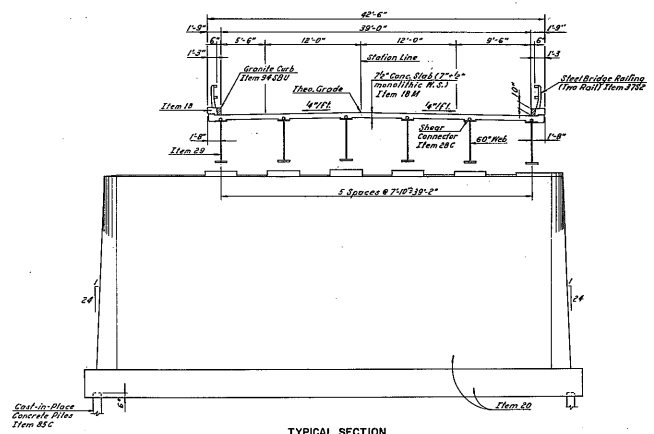
PROFILE-WESTBOUND ROADWAY
Scales: Horiz: 1"=100'
Vert: 1"=10'



PROFILE-EASTBOUND ROADWAY
Scales: Horiz: 1"=100'
Vert: 1"=10'



APPROACH SECTION-EXPRESSWAY
(IN DIRECTION OF TRAVEL)
Scale: 1/4"=1'-0"



TYPICAL SECTION
(IN DIRECTION OF TRAVEL)
Scale: 1/4"=1'-0"

By	Date	Revised
Checked by: <i>F. B. [Signature]</i>		
Designed by: <i>L. [Signature]</i>		
Field Checked by: <i>M. [Signature]</i>		
Reviewed by: <i>G. [Signature]</i>		
Exam. Checked by: <i>H. [Signature]</i>		

BRIDGE NO. 1
EXPRESSWAY OVER CHEMUNG RIVER
SECTIONS AND PROFILES

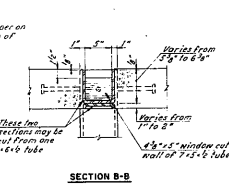
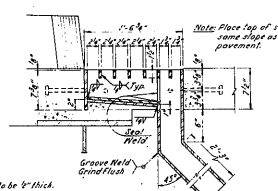
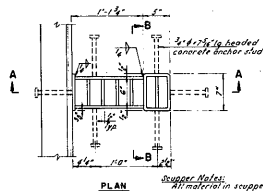
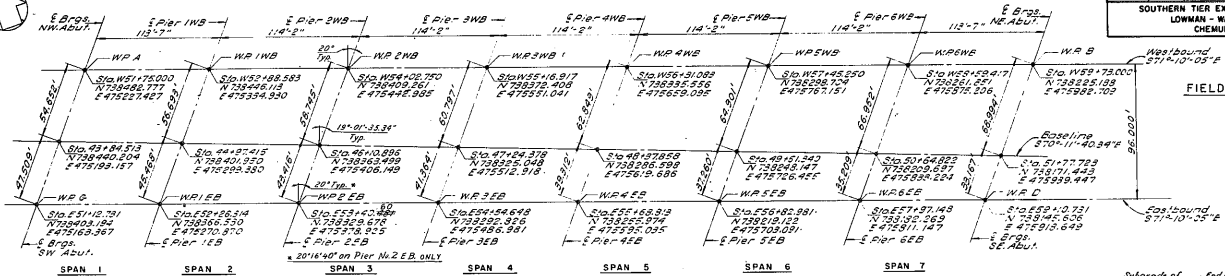
Prepared and recommended
[Signature]
ENGINEER & ARCHT.
Consulting Engineers

DWG. NO.	SCALE	DATE	ENGINEERS
2 of 16	As Shown	4/1/49	COOKING & ODEA CONSULTING ENGINEERS

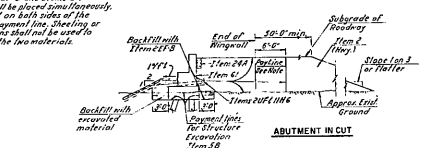
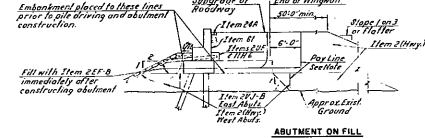
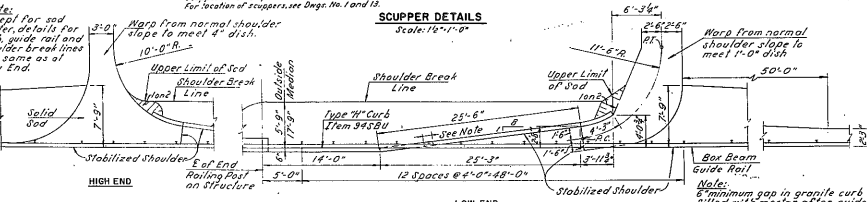
FED. ROAD DIST. NO.	STATE	FEDERAL AID PROJECT NO.	SHEET NO.	TOTAL SHEETS
1	N.Y.	APD-221(21)	87-F-199	199

SOUTHERN TIER EXPRESSWAY OVER CHEMUNG RIVER
LOWMAN - WAVERLY PART I
CHEMUNG COUNTY

FIELD CHANGE SHEET



SCUPPER DETAILS

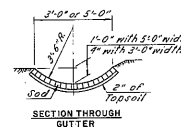


PAYMENT LINES AND DETAILS

Scale: 1/2" = 5'-0"

REVISIONS

1. SKEW ANGLE 20°16'40" ON PIER NO. 2 EB. ONLY



BRIDGE NO. 1

EXPRESSWAY OVER CHEMUNG RIVER
LAYOUT PLAN & DRAINAGE DETAILS

By	Date	Revised
Checked by: [Signature]		
Designed by: [Signature]		
Drawn by: [Signature]		
Field Checked by: [Signature]		

DRAINAGE DETAILS AT ENDS OF BRIDGE

Scale: 3/8" = 1'-0"

Prepared and recommended by: [Signature]
BOOKEND & O'NEA

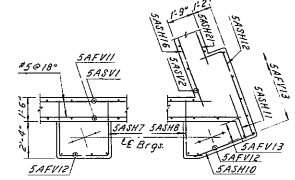
Date: 4/19/49
Consulting Engineer

REV. NO.	SCALE	DATE	GOODING & O'NEA CONSULTING ENGINEERS
3 OF 16	AS SHOWN	4/19/49	

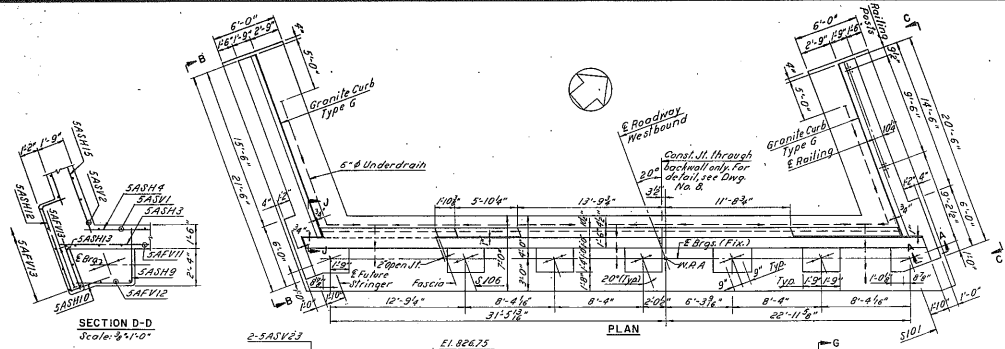
FED. ROAD DIST. NO.	STATE	FEDERAL AID PROJECT NO.	SHEET NO.	TOTAL SHEETS
1	N.Y.	APD-221 (21)	88-F1	199

SOUTHERN TIER EXPRESSWAY SECTION 6A
LOWMAN - WAVERLY PART I
CHEMUNG COUNTY

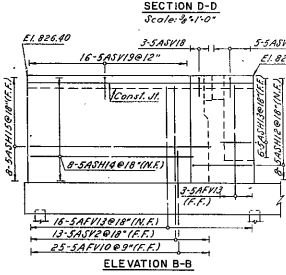
FIELD CHANGE SHEET
SHEET No. 88F1. VOIDS ALL OF ORIGINAL SH. No. 88



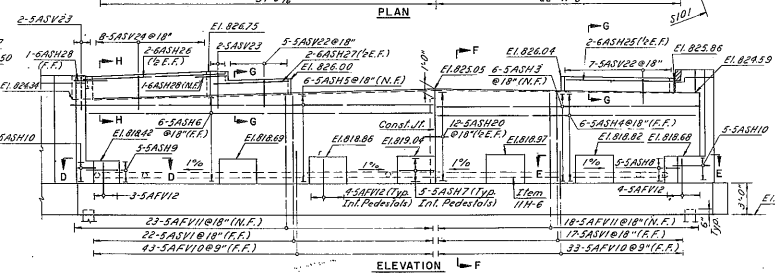
SECTION E-E
Scale: 3/4"=1'-0"



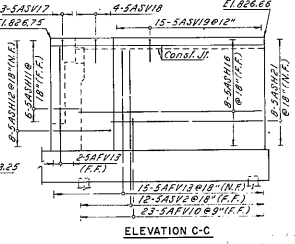
PLAN



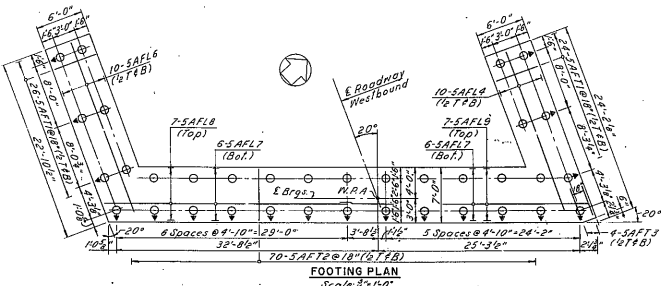
SECTION D-D
Scale: 3/4"=1'-0"



ELEVATION F



ELEVATION C-C



FOOTING PLAN
Scale: 1/2"=1'-0"

- REFERENCES:**
- For Bar List, see Dwg. No. 16.
 - For Rebar Details, see Dwg. No. 15.
 - For Anchor Bolt and Bearing Details, see Dwg. No. 12.
 - For Pile Detail, see Dwg. No. 10.
 - For Layout Plan, see Dwg. No. 3.
 - For Abutment Details, Sections A-A and F-F, see Dwg. No. 8.
 - For Sections G-G, H-H and J-J, see Dwg. No. 6.

- PILE NOTES:**
- All Piles to be C.I.P. Concrete Piles.
 - Ø denotes vertical pile.
 - Ø denotes pile battered on Ø in direction of arrow.
 - For design purposes, the pile load does not exceed 35 tons per pile.
 - Piles to be driven to a tip elevation no higher than 786.00.
 - Estimated length of piles is 40 feet.

AS BUILT REVISIONS

BRIDGE NO. 1
EXPRESSWAY OVER CHEMUNG RIVER
NW ABUTMENT

Prepared and recommended by: *[Signature]* Date: *[Date]*
Checked by: *[Signature]* Consulting Engineer

DWG. NO.	DATE	BY	REVISION
88-F1	6/2/18	J.R.	AS BUILT

GODKIND & O'NEAL
CONSULTING ENGINEERS

F.A.S.T.E. 67-4

In Charge of	Date	Revision
<i>[Signature]</i>		
<i>[Signature]</i>		
<i>[Signature]</i>		
<i>[Signature]</i>		



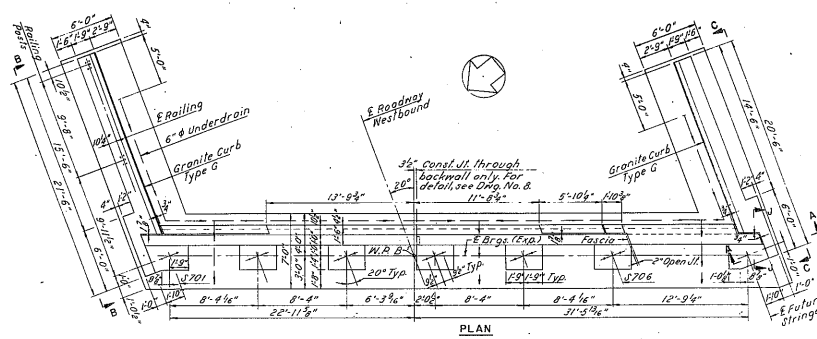
F.A.S.T.E. 67-4

FED. ROAD REG. NO.	STATE	FEDERAL AID PROJECT NO.	SHEET NO.	TOTAL SHEETS
1	N.Y.	APD-22(21)	29/71	199

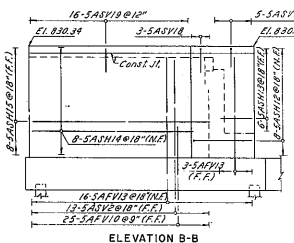
SOUTHERN TIER EXPRESSWAY SECTION GR
LOWMAN - WAVERLY PART I
CHEMUNG COUNTY

FIELD CHANGE SHEET

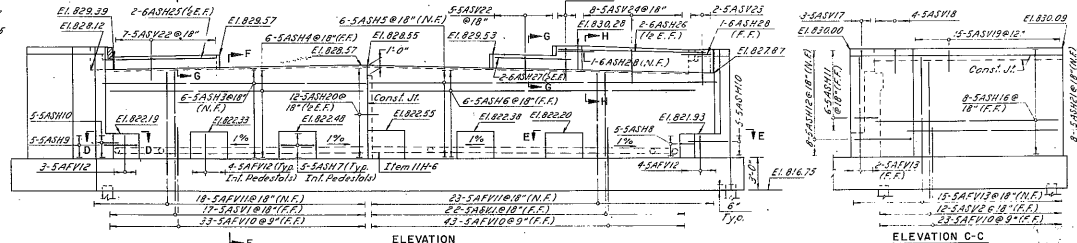
SHEET NO. 89-FI VOIDS ALL OF ORIGINAL SH.NO.89



PLAN

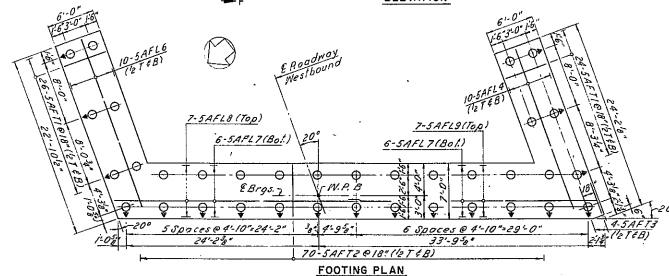


ELEVATION B-B



ELEVATION

ELEVATION C-C



FOOTING PLAN

- REFERENCES:**
1. For Bar List, see Dwg. No. 16.
 2. For Walling Details, see Dwg. No. 15.
 3. For Anchor Bolt and Bearing Details, see Dwg. No. 12.
 4. For Pile Details, see Dwg. No. 18.
 5. For Layout Plan, see Dwg. No. 3.
 6. For Abutment Details, sections A-A and F-F, see Dwg. No. 8.
 7. For Sections D-D and E-E, see Dwg. No. 4.
 8. For Sections G-G, H-H and J-J, see Dwg. No. 6.
- PILE NOTES:**
1. All Piles to be C.I.R. Concrete Piles.
 2. 3' Denotes vertical pile.
 3. 6" Denotes pile battered on 6 in direction of arrow.
 4. For design purposes the pile load does not exceed 35 tons per pile.
 5. Piles to be driven to a tip elevation no higher than EL. 788.00.
 6. Estimated length of piles is 30 feet.

NO AS BUILT REVISIONS

BRIDGE NO. 1
EXPRESSWAY OVER CHEMUNG RIVER
NE ABUTMENT

in Charge of	Date	Revision
Designed by <i>F. B. Quinn</i>		
Drawn by <i>M. J. McLaughlin</i>		
Checked by <i>M. J. McLaughlin</i>		
Field Checked by <i>M. J. McLaughlin</i>		

Prepared and recommended
Goodkind & O'Dea
Consulting Engineers

DWG. NO.	SCALE	DATE	GOODKIND & O'DEA CONSULTING ENGINEERS
5 of 16	1/4" = 1'-0"	5/22/66	

F.A.S.T.E. 67-4

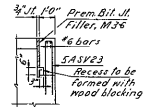


FED. ROAD DIST. NO.	STATE	FEDERAL AID PROJECT NO.	SHEET NO.	TOTAL SHEETS
1	N.Y.	APD-221(21)	30-F-1	199

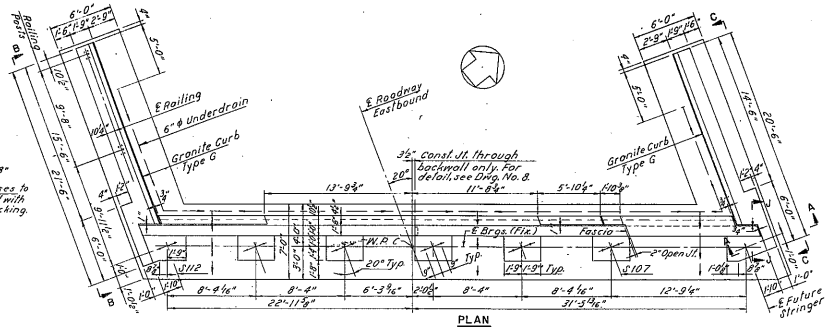
SOUTHERN TIER EXPRESSWAY SECTION 8A
LOWMAN - WAVERLY PART I
CHEMUNG COUNTY

FIELD CHANGE SHEET

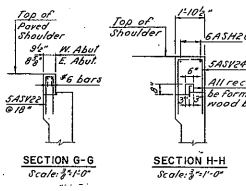
SHEET No. 90-F.1. VOIDS ALL OF ORIGINAL SH. No 90



SECTION J-J
Scale: 3/4\"/>

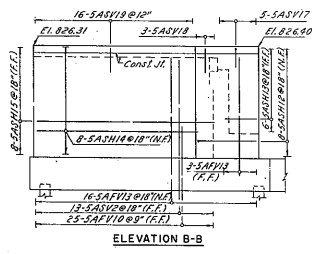


PLAN

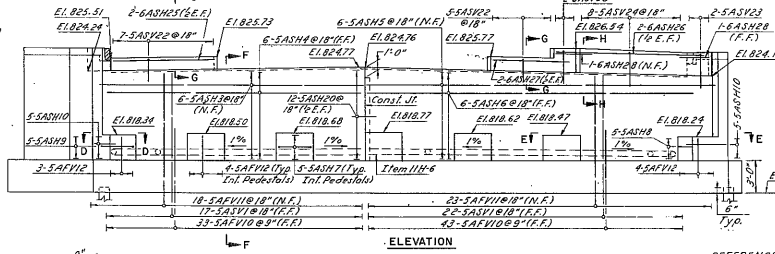


SECTION G-G
Scale: 3/4\"/>

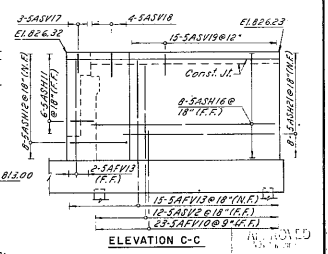
SECTION H-H
Scale: 3/4\"/>



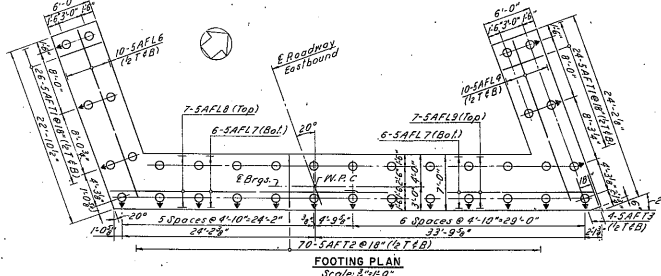
ELEVATION B-B



ELEVATION



ELEVATION C-C



FOOTING PLAN
Scale: 1/4\"/>

- REFERENCES:
- 1 For Bar List, see Dwg. No. 16.
 - 2 For Railing Details, see Dwg. No. 15.
 - 3 For Anchor Bolt and Bearing Details, see Dwg. No. 12.
 - 4 For Pile Detail, see Dwg. No. 10.
 - 5 For Layout Plan, see Dwg. No. 3.
 - 6 For Abutment Details, sections A-A and F-F, see Dwg. No. 8.
 - 7 For Sections D-D and E-E, see Dwg. No. 9.

- PILE NOTES:
- 1 All Piles To be C.I.P. Concrete Piles.
 - 2 O Denotes vertical pile.
 - 3 O Denotes pile battered on B in direction of arrow.
 - 4 For design purposes the pile load does not exceed 35 tons per pile.
 - 5 Piles to be driven to a tip elevation no higher than El. 702.00.
 - 6 Estimated length of pile is 50 feet.

NOT AS BUILT REVISIONS

In Charge of	Date	Revisions
<i>E. Bolger</i>		
<i>W. S. ...</i>		
<i>...</i>		
<i>...</i>		

Prepared and recommended by *...*
Checked by *...*

Date: *...*
Crossing Engineers

BRIDGE NO. 1
EXPRESSWAY OVER CHEMUNG RIVER
SW ABUTMENT

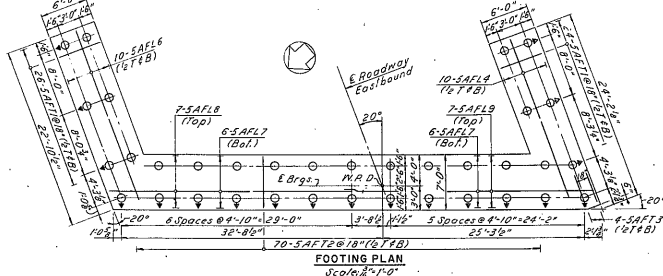
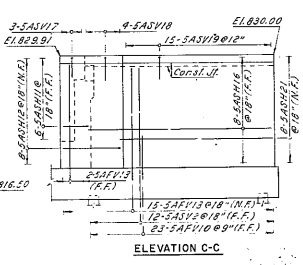
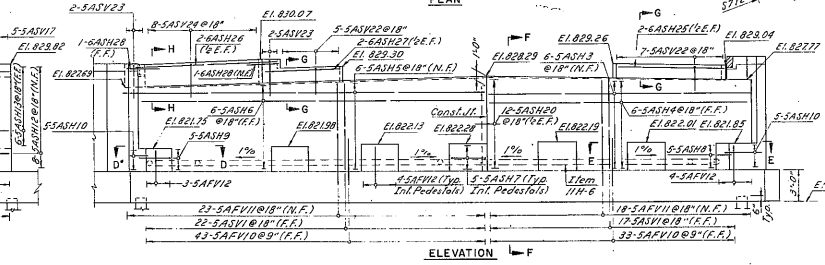
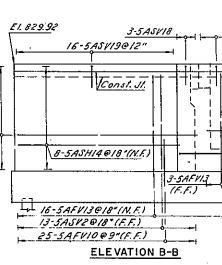
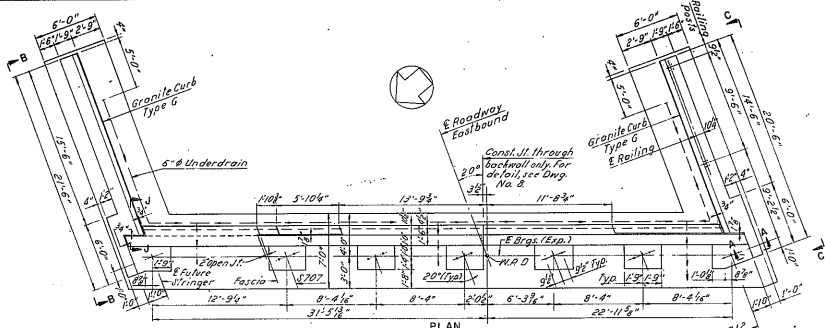
DWG. NO.	SCALE	DATE	ENGINEER
60716	1/4\"/>		

FED. ROAD DIST. NO.	STATE	FEDERAL AID PROJECT NO.	SHEET NO.	TOTAL SHEETS
1	N.Y.	APD-221 (21)	91-FI	159

SOUTHERN TIER EXPRESSWAY SECTION BR LOWMAN - HAVERLY PART I CHEMUNG COUNTY

FIELD CHANGE SHEET

SHEET No. 91-FI VOIDS ALL OF ORIGINAL SH. No. 91



- REFERENCES:**
1. For Bar L's, see Dwg. No. 16
 2. For Piling Details, see Dwg. No. 15
 3. For Anchor Bolt and Bearing Details, see Dwg. No. 12
 4. For Pile Details, see Dwg. No. 14
 5. For Layout Plans, see Dwg. No. 3
 6. For Abutment Details, Sections A-A and F-F, see Dwg. No. 8
 7. For Sections D-D and E-E, see Dwg. No. 4
 8. For Sections G-G, H-H and U-U, see Dwg. No. 6
- PILE NOTES:**
1. All Piles to be C.I.P. Concrete Piles
 2. O Denotes vertical pile
 3. Ⓞ Denotes pile battered 1 on 6 in direction of arrow
 4. For design purposes, the pile load does not exceed 33 tons per pile
 5. Piles to be driven to a tip elevation no higher than 7850
 6. Estimated length of piles is 35 feet

AS BUILT REVISIONS

By	Date	Revised
Checked by		
Designed by		
Drawn by		
Field Checked by		

Prepared & Recommended
GODDARD & OTEA
Consulting Engineers

BRIDGE NO. 1
EXPRESSWAY OVER CHEMUNG RIVER
SE ABUTMENT

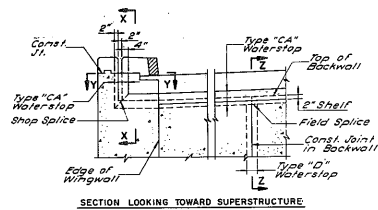
DWG. NO.	SCALE	DATE	DATE	DATE
7 of 16	1" = 10'	10/16		

FED. ROAD DIST. NO.	STATE	FEDERAL AID PROJECT NO.	SHEET NO.	TOTAL SHEETS
1	N.Y.	A14-321(21)	92/19	199

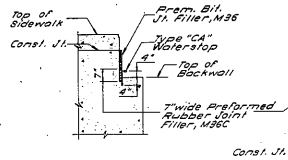
SOUTHERN TIER EXPRESSWAY SECTION 6R
LOWMAN - WAVERLY PART I
CHEMUNG COUNTY

FIELD CHANGE SHEET

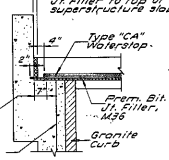
SHEET No. 92/F1 VOIDS ALL OF ORIGINAL SH. No. 92



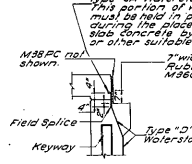
SECTION LOOKING TOWARD SUPERSTRUCTURE



SECTION X-X



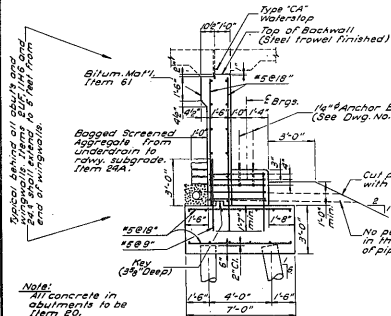
SECTION Y-Y



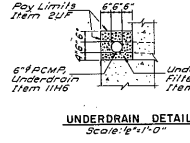
SECTION Z-Z

Glue Preformed Rubber Joint Filler to waterstop with Gasolene-Resistant or Waterbased Contact Cement.

INSTALLATION OF WATERSTOPS
 No Scale

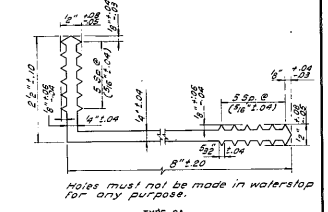


SECTION F-F

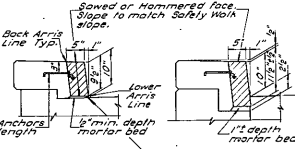


UNDERDRAIN DETAIL

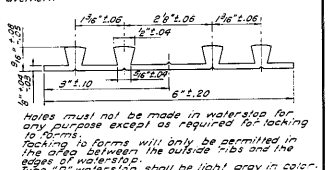
Note: All splices shall be thermal splices. Method for fiber splicing shall be approved by Deputy Chief Engineer, Design. Exposed waterstop must be protected from damage by suitable means during all phases of construction.



TYPE CA

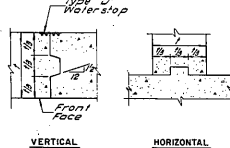


TYPE G WINGWALLS

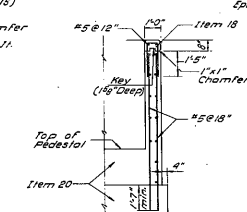


TYPE D

PVC WATERSTOPS (M38T)
 Scale: Full Size

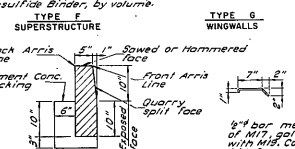


KEY DETAILS

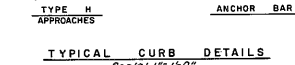


SECTION A-A

Note: All reinforcement in abutment and wingwall sections to be #5 bars unless otherwise noted.



TYPE E SUPERSTRUCTURE



TYPE H APPROACHES



TYPICAL CURB DETAILS

AS BUILT REVISIONS

BRIDGE NO. 1
EXPRESSWAY OVER CHEMUNG RIVER
ABUTMENT DETAILS

DRAW. NO.	SCALE	DATE	GOODING & O'NEA CONSULTING ENGINEERS
8 of 16	A2	4/1/57	

Prepared and recommended by: [Signature] Consulting Engineers

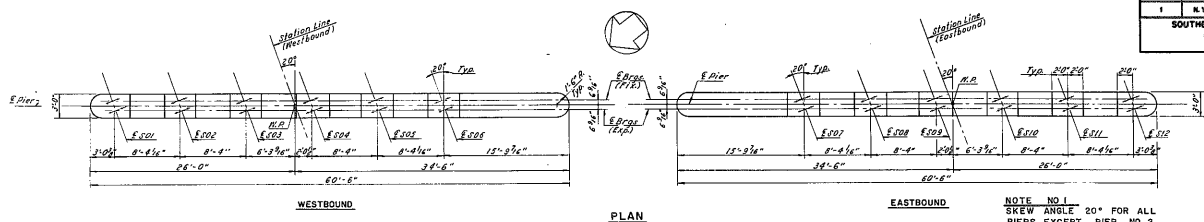
Checked by: [Signature] GOODING & O'NEA CONSULTING ENGINEERS

Scale: Full Size

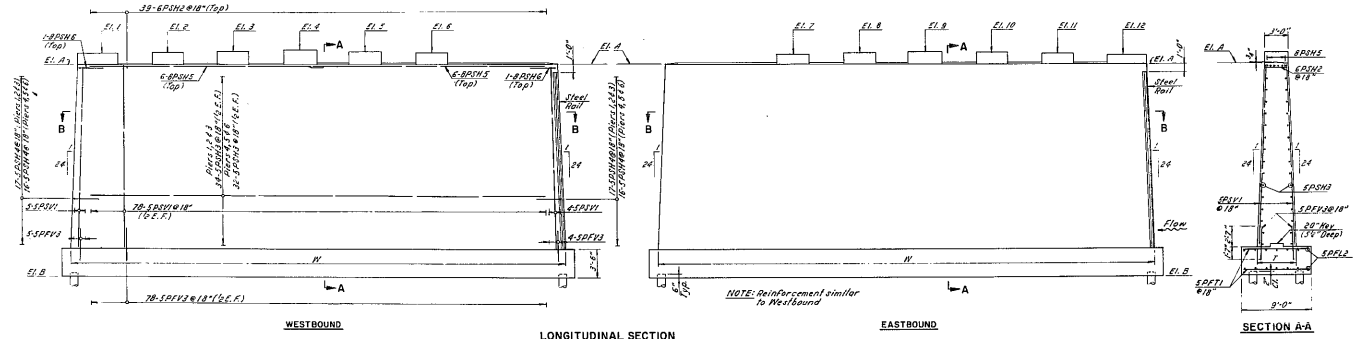


FED. ROAD DIST. NO.	STATE	FEDERAL AID PROJECT NO.	SHEET NO.	TOTAL SHEETS
1	N.Y.		37	139

SOUTHERN Tier EXPRESSWAY SECTION OR LOWMAN - WIVERLY PART I CHEMUNG COUNTY



NOTE NO. 1
SKEW ANGLE 20° FOR ALL
PIERS EXCEPT PIER NO. 2
E.B. WHICH IS 20° 16' 40"



NOTE: Reinforcement similar to Westbound

REVISIONS

1. SEE NOTE NO. 1 EASTBOUND

PIER NO.	1	2	3	4	5	6	EL. A	EL. B	T	W
1WB	819.18	819.32	819.47	819.53	819.68	819.78	789.25	5'-11"	62'-7"	
2WB	819.88	819.92	819.97	820.04	819.96	819.83	816.25	5'-2"	62'-8"	
3WB	820.18	820.32	820.45	820.54	820.71	820.78	789.25	5'-2"	62'-9"	
4WB	820.68	820.82	820.97	821.04	820.87	820.82	816.25	4'-11"	62'-5"	
5WB	821.18	821.32	821.44	821.55	821.87	821.80	819.25	4'-11"	62'-5"	
6WB	821.68	821.82	821.88	821.95	821.87	821.70	820.25	4'-11"	62'-5"	

PIER NO.	7	8	9	10	11	12	EL. A	EL. B	T	W
7EB	819.97	819.92	819.87	819.77	819.00	818.83	817.25	789.25	5'-11"	62'-7"
8EB	819.47	819.52	819.77	819.88	819.50	819.32	816.25	789.25	5'-2"	62'-8"
9EB	819.97	820.12	820.25	820.18	820.00	819.84	816.25	789.25	5'-2"	62'-9"
10EB	820.68	820.82	820.78	820.68	820.50	820.34	819.25	789.25	4'-11"	62'-5"
11EB	820.98	821.12	821.28	821.18	821.01	820.84	819.25	789.25	4'-11"	62'-5"
12EB	821.68	821.82	821.78	821.68	821.51	821.34	820.25	789.25	4'-11"	62'-5"

REFERENCES:
1. For Bar List, see Div. No. 16.
2. For Pier and Pile Details, see Div. No. 10.
3. For Layout Plans, see Div. No. 2.

in Charge of E. Design	Side	Section
Designed by M. E. Kelly		
Design Checked by M. E. Kelly		
Revised by G. J. ...		
Final Checked by L. ...		

Prepared and recommended
by M. E. Kelly
GOODWIN & O'NEAL
Consulting Engineers

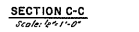
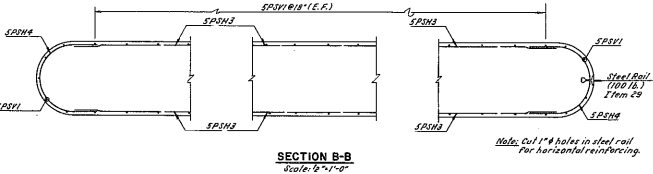
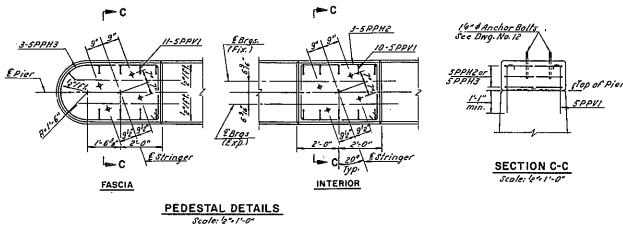
BRIDGE NO. 1 EXPRESSWAY OVER CHEMUNG RIVER PIERS

DWG. NO.	SCALE	DATE	GOODWIN & O'NEAL CONSULTING ENGINEERS
3 of 14	1/2" = 1'-0"	11/10/47	

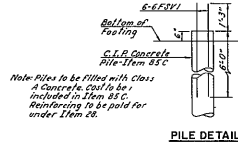


FED. ROAD DIST. NO.	STATE	FEDERAL AID PROJECT NO.	SHEET NO.	TOTAL SHEETS
1	N.Y.	APD-231(21)	34	200

SOUTHERN TIER EXPRESSWAY SECTION 6A
LOWMAN - WAVERLY PART I
CHEMUNG COUNTY

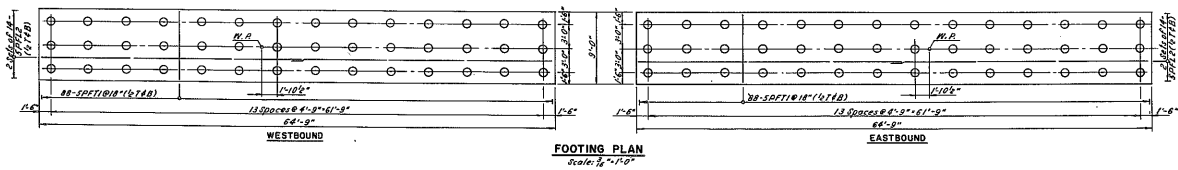


PIER	ESTIMATED PILE LENGTH
TRB	25'
LEB	15'
JWB	20'
WRB	15'
SRB	15'
ENB	20'
LEB	30'
LEB	15'
JEB	20'
JEB	20'
JEB	20'
JEB	15'



PILE NOTES:

- All piles are to be C. I. R. Concrete Piles.
- For design purposes the pile load does not exceed 35 tons per pile.
- Adapted to be driven to a minimum of 10 feet below bottom of footing.
- All piles to be vertical.



REFERENCES:

- For Bar List, see Dwg. No. 16.
- For location of Section B-B, see Dwg. No. 5.

In Charge of Design	Date	Remarks

Prepared and recommended by
WILLIAM J. O'DEA
Consulting Engineers

Date: 4/1/49
Consulting Engineers

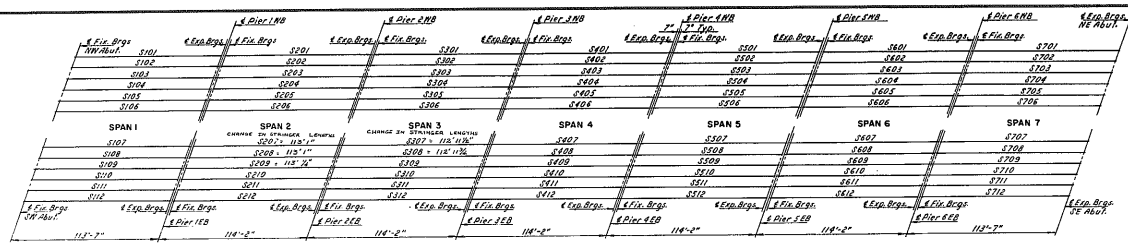
BRIDGE NO. 1
EXPRESSWAY OVER CHEMUNG RIVER
PIER DETAILS

DRAWN BY: J. J. O'DEA
SCALE: AS SHOWN
DATE: 4/1/49

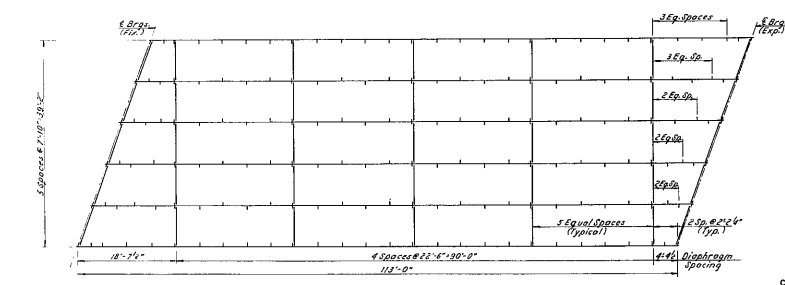
O'DEA & O'DEA
CONSULTING ENGINEERS

FED. ROAD DIST. NO.	STATE	FEDERAL AID PROJECT NO.	SHEET NO.	TOTAL SHEETS
1	TX		51	119

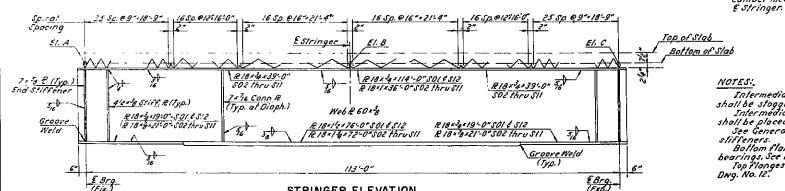
**SOUTHERN TIER EXPRESSWAY SECTION 6R
LOWMAN - WEVERLY PART I
CHEMUNG COUNTY**



KEY PLAN
No Scale



TYPICAL FRAMING PLAN
Scale: 5/8" = 1'-0"



STRINGER ELEVATION
No Scale

STRINGER	STEEL ONLY	TOTAL D.L.
S207	116"	3"
S208	116"	3"
S209	116"	3"
S210	116"	3"
S211	116"	3"
S212	116"	3"

Vertical Curve Camber 0"
Camber measured along E Stringer

NOTES:
1. Intermediate stiffeners for interior stringers should be staggered on each side of the web.
2. Intermediate stiffeners for fascia stringers should be placed on the inside face of the web.
3. See General Notes for methods of connecting stiffeners.
4. Bottom flanges to be cut to 1/2" width of bearing. See Details Dwg. No. 10.
5. Top flanges to be cut to clear joint of piers. See Dwg. No. 12.

BOTTOM OF SLAB ELEVATIONS								
MARK	A	B	C	MARK	A	B	C	
S401	826.24	825.49	825.74	S401	826.25	826.00	827.25	
S402	825.30	825.64	825.89	S402	826.70	826.05	827.20	
S403	825.34	825.79	826.04	S403	826.85	827.15	827.25	
S404	825.61	826.01	826.11	S404	826.70	827.00	827.25	
S405	825.44	825.69	825.83	S405	826.30	826.03	827.08	
S406	825.04	825.29	825.54	S406	827.25	827.50	827.75	
S407	825.19	825.44	825.69	S407	827.40	827.65	827.90	
S408	825.34	825.59	825.84	S408	827.55	827.80	828.05	
S409	825.49	825.74	825.99	S409	827.70	827.95	828.20	
S410	825.64	825.89	826.14	S410	827.85	828.10	828.35	
S411	825.79	826.04	826.29	S411	828.00	828.25	828.50	
S412	825.94	826.19	826.44	S412	828.15	828.40	828.65	
S413	826.09	826.34	826.59	S413	828.30	828.55	828.80	
S414	826.24	826.49	826.74	S414	828.45	828.70	828.95	
S415	826.39	826.64	826.89	S415	828.60	828.85	829.10	
S416	826.54	826.79	827.04	S416	828.75	829.00	829.25	
S417	826.69	826.94	827.19	S417	828.90	829.15	829.40	
S418	826.84	827.09	827.34	S418	829.05	829.30	829.55	
S419	826.99	827.24	827.49	S419	829.20	829.45	829.70	
S420	827.14	827.39	827.64	S420	829.35	829.60	829.85	
S421	827.29	827.54	827.79	S421	829.50	829.75	830.00	
S422	827.44	827.69	827.94	S422	829.65	829.90	830.15	
S423	827.59	827.84	828.09	S423	829.80	830.05	830.30	
S424	827.74	827.99	828.24	S424	829.95	830.20	830.45	
S425	827.89	828.14	828.39	S425	830.10	830.35	830.60	
S426	828.04	828.29	828.54	S426	830.25	830.50	830.75	
S427	828.19	828.44	828.69	S427	830.40	830.65	830.90	
S428	828.34	828.59	828.84	S428	830.55	830.80	831.05	
S429	828.49	828.74	828.99	S429	830.70	830.95	831.20	
S430	828.64	828.89	829.14	S430	830.85	831.10	831.35	
S431	828.79	829.04	829.29	S431	831.00	831.25	831.50	
S432	828.94	829.19	829.44	S432	831.15	831.40	831.65	
S433	829.09	829.34	829.59	S433	831.30	831.55	831.80	
S434	829.24	829.49	829.74	S434	831.45	831.70	831.95	
S435	829.39	829.64	829.89	S435	831.60	831.85	832.10	
S436	829.54	829.79	830.04	S436	831.75	832.00	832.25	
S437	829.69	829.94	830.19	S437	831.90	832.15	832.40	
S438	829.84	830.09	830.34	S438	832.05	832.30	832.55	
S439	829.99	830.24	830.49	S439	832.20	832.45	832.70	
S440	830.14	830.39	830.64	S440	832.35	832.60	832.85	
S441	830.29	830.54	830.79	S441	832.50	832.75	833.00	
S442	830.44	830.69	830.94	S442	832.65	832.90	833.15	
S443	830.59	830.84	831.09	S443	832.80	833.05	833.30	
S444	830.74	830.99	831.24	S444	832.95	833.20	833.45	
S445	830.89	831.14	831.39	S445	833.10	833.35	833.60	
S446	831.04	831.29	831.54	S446	833.25	833.50	833.75	
S447	831.19	831.44	831.69	S447	833.40	833.65	833.90	
S448	831.34	831.59	831.84	S448	833.55	833.80	834.05	
S449	831.49	831.74	831.99	S449	833.70	833.95	834.20	
S450	831.64	831.89	832.14	S450	833.85	834.10	834.35	

REVISIONS

- CHANGE IN STRINGER LENGTHS

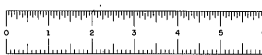
**BRIDGE NO. 1
EXPRESSWAY OVER CHEMUNG RIVER**

Prepared and recommended by: **W. M. Dyer**
 Checked by: **W. M. Dyer**
 Date: **4/1/68**

DATE	NO.	SCALE	DATE
11/01/68	1	AS SHOWN	4/1/68

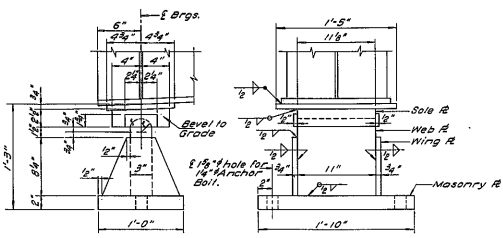
**GOODKIND & ODEA
CONSULTING ENGINEERS**

In Charge of: **C. D. Quinn**
 Designed by: **C. D. Quinn**
 Design Checked by: **W. M. Dyer**
 Detailed by: **C. D. Quinn**
 Steel Checked by: **C. D. Quinn**



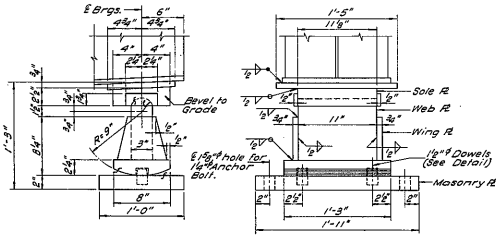
FED. ROAD DIST. NO.	STATE	FEDERAL AID PROJECT NO.	SHEET NO.	TOTAL SHEETS
1	N.Y.	APD-221(21)	36	200

SOUTHERN TIER EXPRESSWAY SECTION 6R
LOWMAN - WAVERLY PART I
CHEMUNG COUNTY

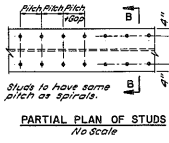


FIXED BEARING
Scale: 2"=1'-0"

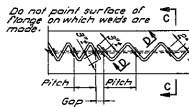
c = 1 3/8" for Web R
c = 1 3/8" for Sole R



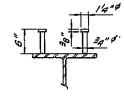
EXPANSION BEARING
Scale: 2"=1'-0"



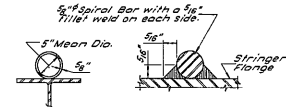
PARTIAL PLAN OF STUDS
No Scale



PARTIAL PLAN OF SPIRALS
No Scale

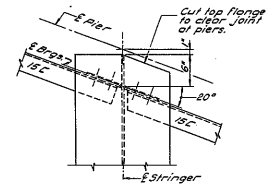


SECTION B-B
No Scale

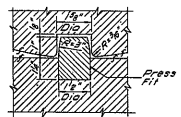


SECTION C-C
No Scale

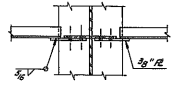
SECTION D-D
Full Size



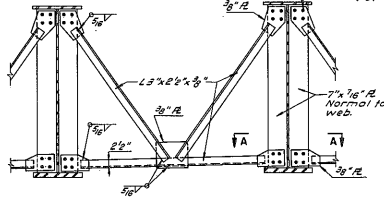
SECTION E-E
Scale: 1 1/2"=1'-0"



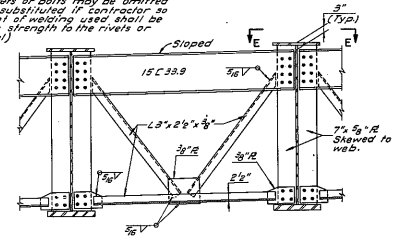
DOWEL DETAIL
Scale: Half Size



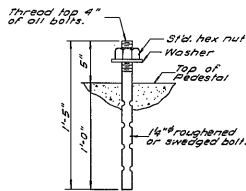
SECTION A-A
Scale: 1 1/2"=1'-0"



INTERMEDIATE

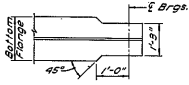


END



ANCHOR BOLT DETAIL
No Scale

DIAPHRAGM DETAILS
No Scale



BOTTOM FLANGE DETAIL
No Scale

REFERENCES:
for Framing Plan, see Dwg. No. 11.

In Charge of	Drawn	Checked
F. B. O'Brien		
Designed by		
Bridge Engineer		
Checked by		
Field Checked by		

BRIDGE NO. 1
EXPRESSWAY OVER CHEMUNG RIVER

STEEL DETAILS

Prepared and recommended by: [Signature]
Consulting Engineers

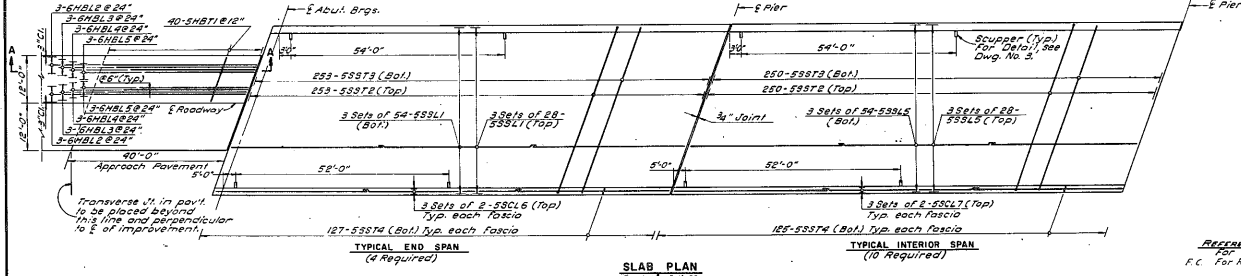
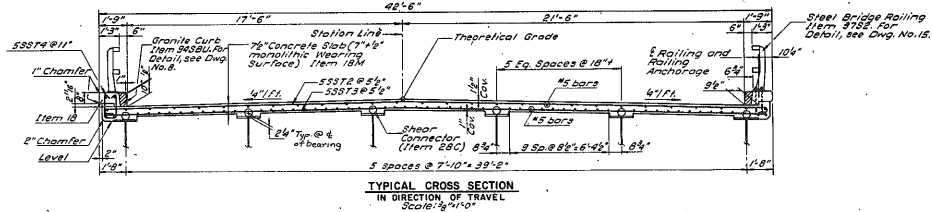
DWG. NO.	SCALE	DATE	DESIGNED & CHECKED
12 OF 16	1/2" = 1'-0"	4/1/49	600KIND & ODEA CONSULTING ENGINEERS

FED. ROAD DIST. NO.	STATE	FEDERAL AID PROJECT NO.	SHEET NO.	TOTAL SHEETS
1	N.Y.	ADP-221(C)13	27-1/R	199

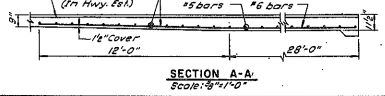
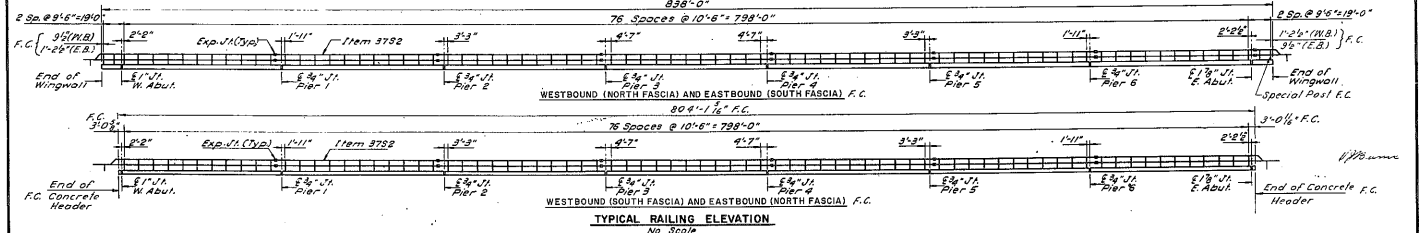
SOUTHERN Tier EXPRESSWAY SECTION OR LOWMAN - WAVERLY PART I CHEMUNG COUNTY

FIELD CHANGE SHEET

SHEET No. 97-FI VOIDS ALL OF ORIGINAL SH. No. 97



REFERENCES:
 For Bar 181, see Dwg. No. 18.
 F.C. for Railing Details, see Dwg. No. 15.



AS BUILT REVISIONS

BRIDGE NO. 1
 EXPRESSWAY OVER CHEMUNG RIVER
 SLAB PLAN AND CROSS SECTION

By	Date	Revised
F. Bolten		
L. Bolten		
M. Bolten		
C. Bolten		

Note:
 Item 28, Bar Reinforcement for Structures, is included in the Bridge Quantities. All other items used in the Reinforced Concrete Approach Pavement are included in the Highway Quantities.

Prepared and maintained by: *[Signature]*
 Checked by: *[Signature]*
 Date: 4/1/61

GOODRICH & ODEA CONSULTING ENGINEERS

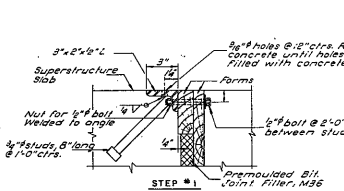


FED. ROAD DIST. NO.	STATE	FEDERAL AID PROJECT NO.	SHEET NO.	TOTAL SHEETS
1	N.Y.	APD-221(21)	36 of 82	199

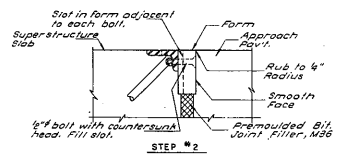
SOUTHERN TIER EXPRESSWAY SECTION BRIDGE - UNIVERSITY PART I CHEMUNG COUNTY

FIELD CHANGE SHEET

SH. No. 98F1 VOIDS ALL OF ORIGINAL SH. No. 98



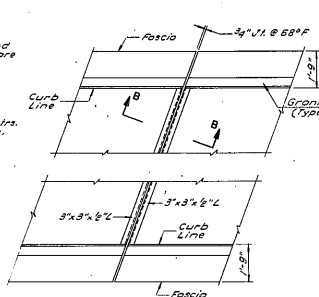
STEP #1
3"x2"x1/2" L and the nuts and studs welded to angle will be paid for under Item 29. Angle to be weldable steel conforming to ASTM A442. All other bolts and washers will be considered as part of the form work and no direct payment will be made for these items.



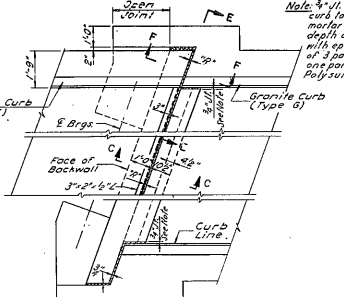
STEP #2
Slab in form adjacent to each bolt. Form Approach Pavt. Rub. to 1/4" Radius. Smooth Face. 1/2" bolt with countersunk head fill slot.

CONSTRUCTION PROCEDURE:
1. Bolt angles to form boards as indicated in Step #1 to proper line and grade.
2. Pour Superstructure Slab.
3. Remove forms and bolts.
4. Place form as indicated in Step #2.
5. Pour Approach Pavement.
6. Cut off bolt flush with angle with sabre saw.
7. Remove form and replace with Preformed Elastic Joint Sealer.

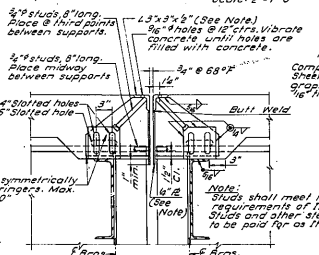
DETAILS OF ARMORING ANGLE AT ABUTMENT
Scale: 3/4"=1'-0"



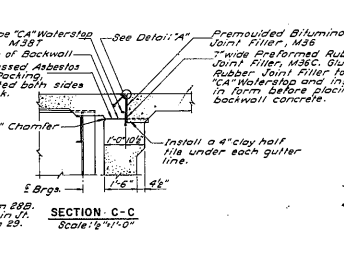
PIERS
Scale: 1/2"=1'-0"



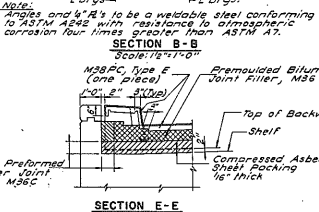
EAST ABUTMENT WESTBOUND, SHOWN OTHER ABUTMENTS SIMILAR



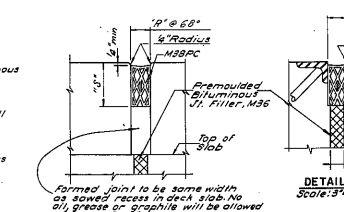
SECTION B-B
Scale: 1/2"=1'-0"



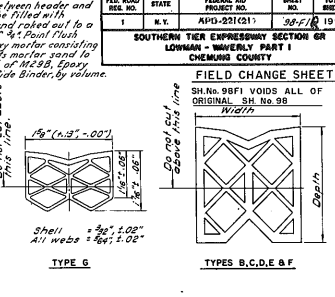
SECTION C-C
Scale: 1/2"=1'-0"



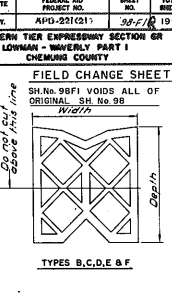
SECTION E-E
Scale: 1/2"=1'-0"



SECTION F-F
No Scale



TYPE G
Shell: 1/2" x 1/2" x 1/2"
All webs: 1/2" x 1/2"



TYPES B, C, D, E & F

DIMENSIONS FOR TYPES B, C, D, E & F

TYPE	WIDTH	DEPTH	SEALER THICKNESS
B	12" x 12"	2" x 1/2"	3/8" x 3/8"
C	2" x 2"	2 1/2" x 1 1/2"	3/8" x 3/8"
D	2 1/2" x 2 1/2"	2 1/2" x 1 1/2"	3/8" x 3/8"
E	3" x 3"	2 1/2" x 1 1/2"	3/8" x 3/8"
F	4" x 4"	2 1/2" x 1 1/2"	3/8" x 3/8"

Any changes in the shape or dimensions of Preformed Elastic Joint Sealer must be approved by the Deputy Chief Engineer, Design. The minimum thickness of any web shall not be less than as specified. The average thickness of all webs shall be within the tolerances specified.

PREFORMED ELASTIC JOINT SEALER - M38PC
No Scale

AS BUILT REVISIONS

Note: "R" is the amount that "R" must be decreased for every 10° rise in temperature or increased for every 10° fall in temperature.

ABUT. NO.	M38PC TYPE	R	S	X	T
West	B	7	2 1/2	4	-
East	C	2	2 1/2	1 1/2	2 1/2

References:
101 - Details of Waterstop Installation see Dwg. No. 8.

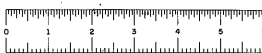
BRIDGE NO. 1
EXPRESSWAY OVER CHEMUNG RIVER

JOINT DETAILS

Prepared and recommended by: [Signature]
Checked by: [Signature]
Date: 4/11/70
Consulting Engineers

GOODKIND & O'DEA CONSULTING ENGINEERS
F.A.S.T.E. 67-4

By	Date	Revised

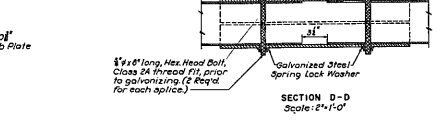
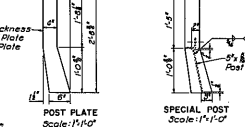
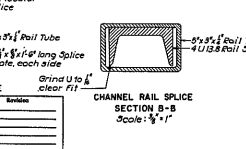
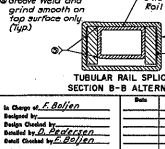
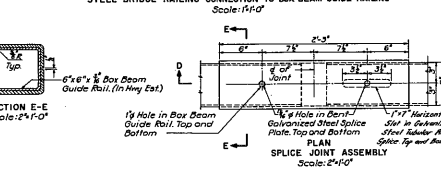
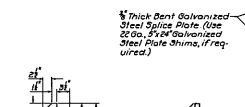
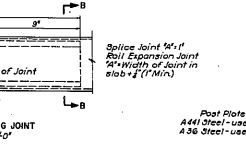
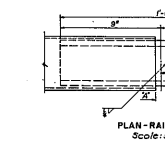
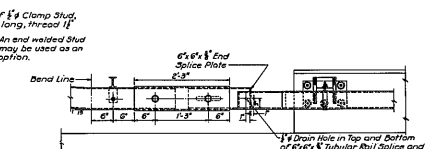
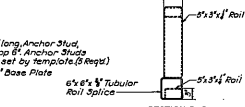
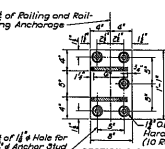
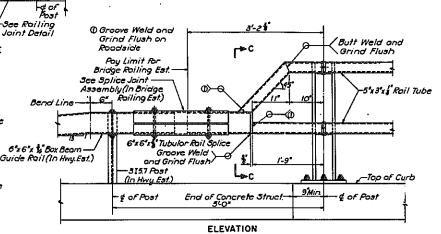
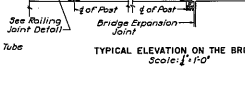
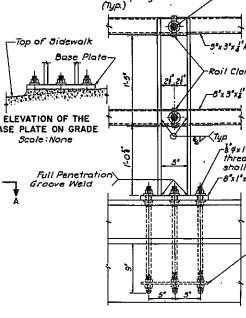
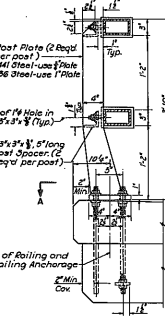


FED. ROAD DIST. NO.	STATE	FEDERAL AID PROJECT NO.	SHEET NO.	TOTAL SHEETS
1	N.Y.	APD-221(2)13	39	200

SOUTHERN TIER EXPRESSWAY SECTION BR
DOWNMAN - WAVERLY PART I
CHEMUNG COUNTY

NOTE:
Grind corners of post plate to $\frac{1}{4}$ " radius.

NOTE: For Rolling Rail Spacing, see Comp. No. 12.



In Charge of *E. Bolton*
Designed by _____
Checked by *D. Duff*
Field Checked by *C. G. [illegible]*

Date	Revision

Post Plate thickness
A441 Steel - use $1/2"$ Plate
A56 Steel - use $1"$ Plate

Prepared and recommended
[Signature]
Checked by *[Signature]*

Notes:
All railing is to be fabricated and erected so that the rails are parallel to each other and to the parapet and so that the posts are truly vertical. Since the finished railing must meet all requirements of fit, alignment, grade and verticality of post to the full satisfaction of the Engineer, it is expected that complete field measurements be made before any shop fabrication is performed.
The Base Plates shall be perpendicular to the post unless otherwise noted. When the railing is to be placed on a prepared surface, the Base Plate may be parallel to the grade or may be perpendicular to the post and made level by the use of leveled shims.
Subsidiary steel railing shall consist of assemblies including steel rails, rail clamps, post, post web plates and splice joint railing assemblies including steel bridge railing connection to the box beam guide railing and any necessary shims and/or pads shall be field fit under the railing.
Anchor studs, nuts, washers and anchor plates shall be placed in accordance with the drawings. The studs shall be cut off $1/8$ "- $1/4$ " above the nut and bent.
Rails shall be continuous over a minimum of three posts. On "W" type wideflats the rails may be continuous over two posts.
Materials used in the manufacture of this railing shall conform to the requirements and/or specifications listed below:
Rail Tubes - ASTM Designation A500 Grade B
Rail Clamps - ASTM Designation A56
Clamp Studs, nuts and washers - ASTM Designation A307
Channel Rail Splices - ASTM Designation A36
Tubular Rail Splices - ASTM Designation A300 Grade B or A501
Splice Plates - ASTM Designation A36
 $1/2"$ Post Plates - ASTM Designation A441
 $1"$ Post Plates - ASTM Designation A36
Post Splices - same as post plate material
Base Plates - same as post plate material
Splice bolts, nuts and washers - ASTM Designation A497
Anchor Plates - ASTM Designation A36
Post Web Plates - same as post plate material
Plate Shims - ASTM Designation A36
Beveled Shims - Material Specification M13
Galvanized Railing - All components of the railing including anchor studs, nuts, and washers shall be galvanized in accordance with Material Specification M13. Anchor studs shall have a Class 2K thread fit prior to galvanizing. The cut portion of the anchor studs shall be given one field coat of Zinc Chromate Primer and two field coats of Heavy Mixed Aluminum Paint conforming to the requirements of Material Specifications M13A and M13B in that order.

BRIDGE NO. 1
EXPRESSWAY OVER CHEMUNG RIVER

RAILING DETAILS

NO.	SCALE	DATE	DESIGNED BY	CHECKED BY
1	As Shown	11/17	[Signature]	[Signature]

Consult

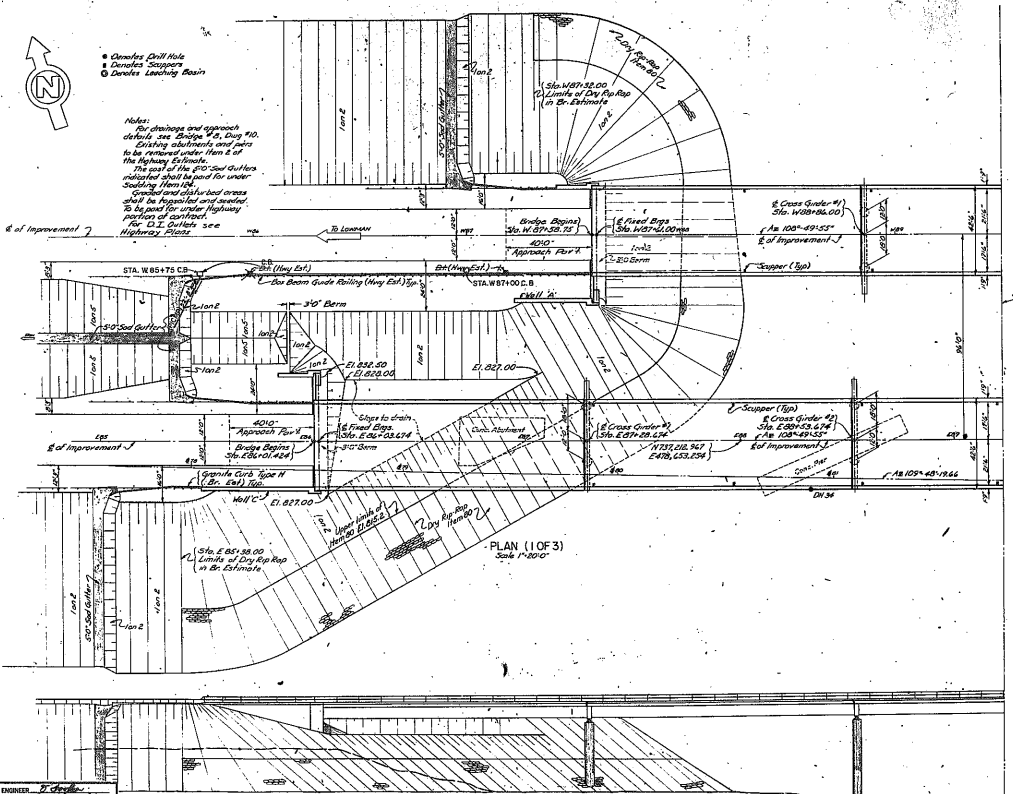
DWG. NO.	STATE	FEDERAL PROJECT NO.	SHEET NO.	TOTAL SHEETS
APD-221(2)17	NEW YORK		10/RL	199

DWG. NO.	SUBJECT
1-2	Layout
3	Layout & Sections
4	Profile
5-9	Embankment Details
10-16	Abutments & Details
17-23	Shedding & Details
24	Piers & Details
25	Framing Plans
26	Decking & Bearings
27-29	Cross Girders & Details
30-34	Approach Slabs & Supports
35-36	Slab Bar Layout
37	Joint Details
38	Abutting Layout
39	Bar Lists
40-44	Bar Lists



• Concrete Drill Hole
 • Concrete Sagger
 • Concrete Landing Basin

Notes:
 All dimensions and approach details see Bridge 14, Day #10. Existing abutments and piers to be retained under item 2 of the Highway Estimate. The end of the 48" Solid Gullies indicated shall be placed for under existing floor. Gravel and crushed areas shall be repaired and needed to be placed for under Highway portion of contract. For D.S. Details see Highway 14.



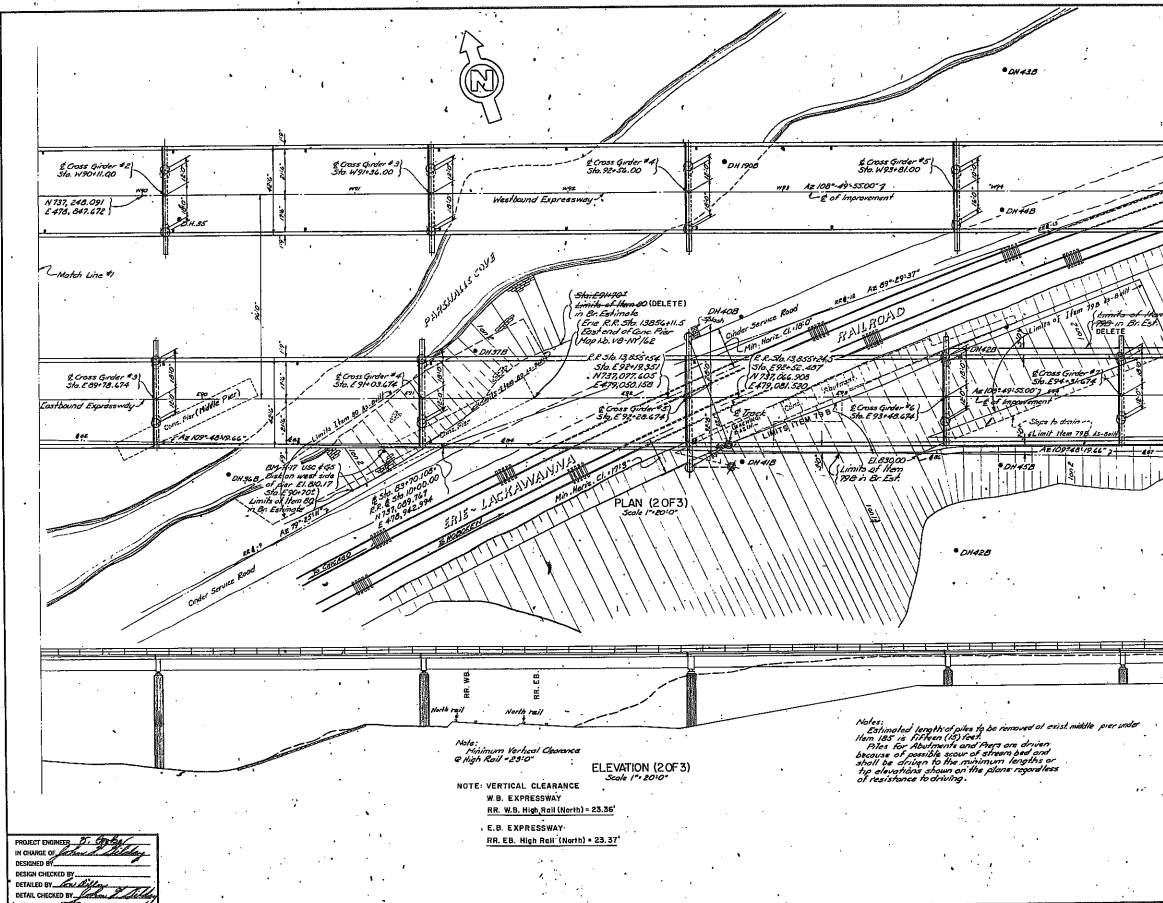
ELEVATION (1 OF 3)
Scale 1" = 20'0"

REVISIONS
 1. LOCATION OF C.B., W.B. RL
 8. 32"-8" PIPE (STA. W85+75)

PROJECT ENGINEER: *[Signature]*
 IN CHARGE OF: *[Signature]*
 DESIGNER: *[Signature]*
 DESIGN CHECKED BY: *[Signature]*
 DETAILED BY: *[Signature]*
 DETAIL CHECKED BY: *[Signature]*

SPEC. BR. 2
 HORIZONTAL CURVE INFORMATION
 OVER 1311-LACKAWANNA R.R.
LAYOUT
 DRAWING NO. 1 OF 44

JOB NO.	STATE	PROJECT NO.	PIER	JOBS
	NEW YORK	APD-221(01)	2	199
PROJECT: WEST BOUNDARY BRIDGE LOCATION: WEST BOUNDARY BRIDGE DRAWING NO. 2 OF 4.4				



REVISIONS

1. LIMITS OF ITEM 80
2. LIMITS OF ITEM 798
3. NOTE ABOUT MIN. VERT. CLEARANCE
4. COLUMNS PLOTTING PIERS No. 2, No. 3, No. 4 & No. 5, West Bound.
5. LEACHING BASIN LOCATION (Pier No. 5 EB)

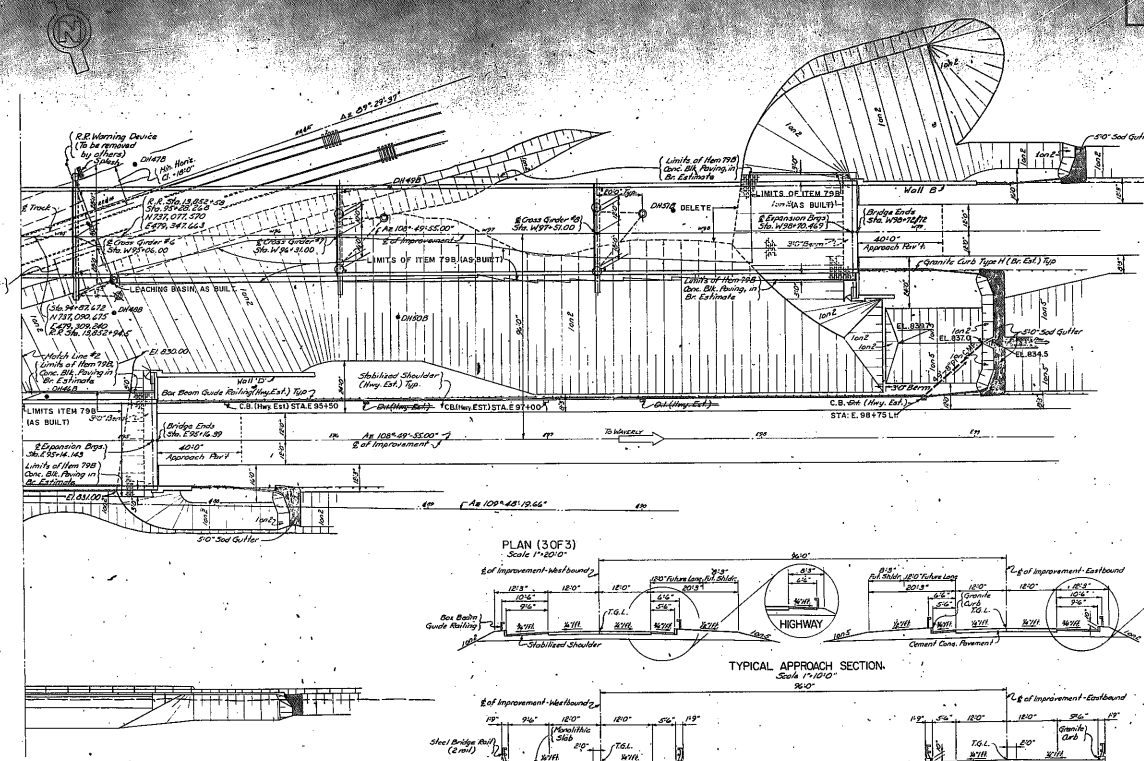
ELEVATION (2 OF 3)
Scale 1" = 20'-0"

NOTE: VERTICAL CLEARANCE
 W.B. EXPRESSWAY
 RR. W.B. High Rail (North) = 23.30'
 E.B. EXPRESSWAY
 RR. E.B. High Rail (North) = 23.31'

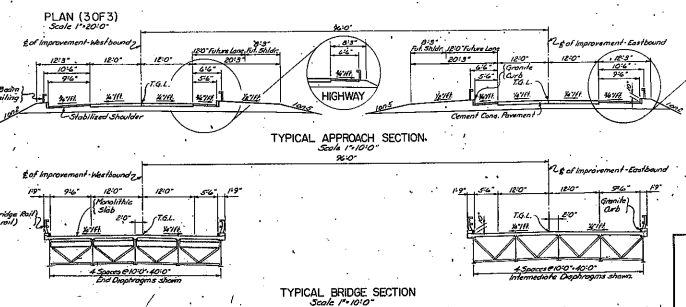
Notes: Extended length of piles to be removed at east abutment per order item 805 in 1/24/00 (13) Deck
 Piles for Abutment and there are shown because of possible space of stream bed and shall be subject to the maximum lengths or top elevations shown on the plans regardless of clearance to driving.

PROJECT ENGINEER: *[Signature]*
 IN CHARGE OF: *[Signature]*
 DESIGNED BY: *[Signature]*
 DESIGN CHECKED BY: *[Signature]*
 DETAIL BY: *[Signature]*
 DETAIL CHECKED BY: *[Signature]*

NO. 2 OF 4.4
 SOUTHERN WEST EXPRESSWAY
 OVER ERIE-LACKAWANNA R.R.
 LAYOUT
 DRAWING NO. 2 OF 4.4



- REVISIONS**
1. LIMITS OF ITEM 798
 2. LEACHING BASIN LOCATION, (PIER No. 6 W/S)
 3. COLUMNS PLOTTING, West Bound Piers No. 7, No. 8.
 4. C.B. LOCATION STAS. E 98450, E 97400
 5. P/CMP (45'-8"), C.B. ON STA. E 98475 L
 6. MEDIAN GRADING ELEVATIONS



Notes:

For General Bridge Notes see Day No. 52 -
 For Details of Spacing see Day No. 52 -
 For Details of Leaching Basin see Standard
 Sheet 52-4. It is paid for under Item 100.
 All Anchor Bolts to be paid for under
 Item 59.

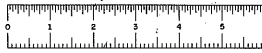
For D.I. Cullies see Highway Plans.
 Frames and gables for Leaching Basin
 to be paid for under Item 30 C.
 Excavation and backfill for Leaching
 Basin to be paid for under Item 52.

PROJECT ENGINEER: *[Signature]*
 IN CHARGE OF: *[Signature]*
 DESIGN CHECKED BY: *[Signature]*
 DETAIL CHECKED BY: *[Signature]*

ELEVATION (3 OF 3)
Scale 1"=20'-0"

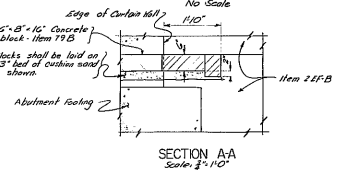
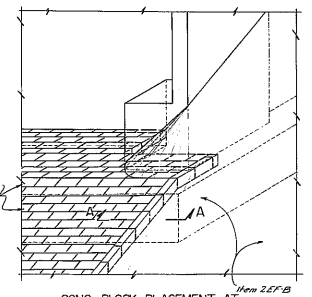
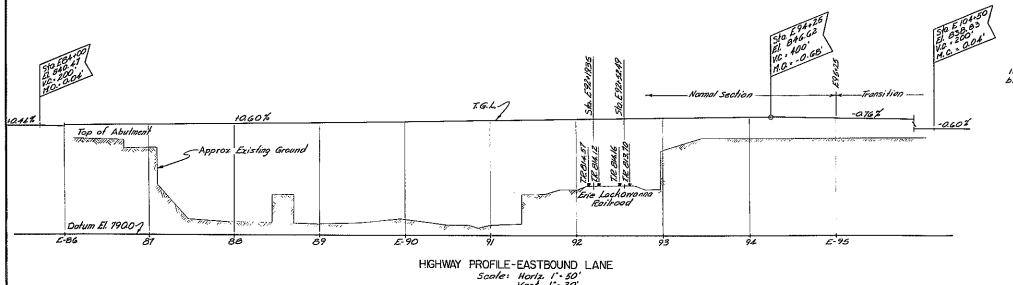
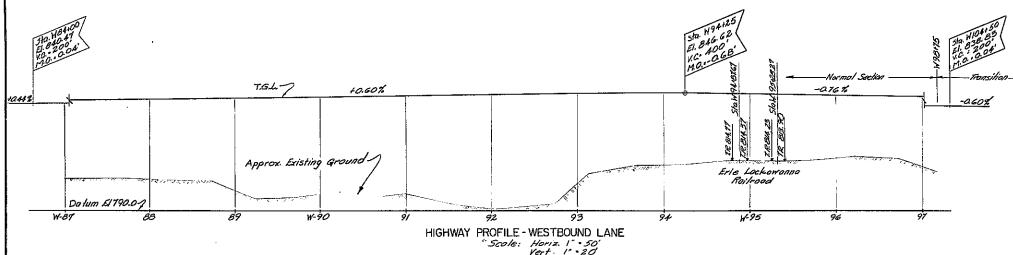
LAYOUT & TYPICAL SECTIONS

DRAWING NO. 3 OF 4-L



FED. PROJ. NO.	STATE	FEDERAL AID PROJECT NO.	SHEET NO.	TOTAL SHEETS
	NEW YORK	APD-221(C)19	104	200

SOUTHERN STATE EXPRESSWAY, SECTION 6A
LONGHUBWAY, PART 1
CHEROKEE COUNTY



Note: (W) High Rail West bound Track
(E) High Rail East bound Track

Note: Station shown are along R.R. Survey & Elevation shown are on a line perpendicular to Survey & used taken from Survey Notes.

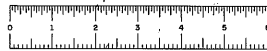
Top of Rail

Station	Elevation	Station	Elevation	Station	Elevation	Station	Elevation
88+00	10.602	89+00	10.602	90+00	10.602	91+00	10.602
88+10	10.602	89+10	10.602	90+10	10.602	91+10	10.602
88+20	10.602	89+20	10.602	90+20	10.602	91+20	10.602
88+30	10.602	89+30	10.602	90+30	10.602	91+30	10.602
88+40	10.602	89+40	10.602	90+40	10.602	91+40	10.602
88+50	10.602	89+50	10.602	90+50	10.602	91+50	10.602
88+60	10.602	89+60	10.602	90+60	10.602	91+60	10.602
88+70	10.602	89+70	10.602	90+70	10.602	91+70	10.602
88+80	10.602	89+80	10.602	90+80	10.602	91+80	10.602
88+90	10.602	89+90	10.602	90+90	10.602	91+90	10.602
89+00	10.602	89+00	10.602	90+00	10.602	91+00	10.602
89+10	10.602	89+10	10.602	90+10	10.602	91+10	10.602
89+20	10.602	89+20	10.602	90+20	10.602	91+20	10.602
89+30	10.602	89+30	10.602	90+30	10.602	91+30	10.602
89+40	10.602	89+40	10.602	90+40	10.602	91+40	10.602
89+50	10.602	89+50	10.602	90+50	10.602	91+50	10.602
89+60	10.602	89+60	10.602	90+60	10.602	91+60	10.602
89+70	10.602	89+70	10.602	90+70	10.602	91+70	10.602
89+80	10.602	89+80	10.602	90+80	10.602	91+80	10.602
89+90	10.602	89+90	10.602	90+90	10.602	91+90	10.602

TRACK	LOCATION	AT PIERS	#	SIZE	OFFSET
W	1	W	1	12x12	24"
W	2	W	1	12x12	24"
W	3	W	1	12x12	24"
W	4	W	1	12x12	24"
W	5	W	1	12x12	24"
W	6	W	1	12x12	24"
W	7	W	1	12x12	24"
W	8	W	1	12x12	24"
W	9	W	1	12x12	24"
W	10	W	1	12x12	24"
W	11	W	1	12x12	24"
W	12	W	1	12x12	24"
W	13	W	1	12x12	24"
W	14	W	1	12x12	24"
W	15	W	1	12x12	24"
W	16	W	1	12x12	24"
W	17	W	1	12x12	24"
W	18	W	1	12x12	24"
W	19	W	1	12x12	24"
W	20	W	1	12x12	24"
W	21	W	1	12x12	24"
W	22	W	1	12x12	24"
W	23	W	1	12x12	24"
W	24	W	1	12x12	24"
W	25	W	1	12x12	24"
W	26	W	1	12x12	24"
W	27	W	1	12x12	24"
W	28	W	1	12x12	24"
W	29	W	1	12x12	24"
W	30	W	1	12x12	24"
W	31	W	1	12x12	24"
W	32	W	1	12x12	24"
W	33	W	1	12x12	24"
W	34	W	1	12x12	24"
W	35	W	1	12x12	24"
W	36	W	1	12x12	24"
W	37	W	1	12x12	24"
W	38	W	1	12x12	24"
W	39	W	1	12x12	24"
W	40	W	1	12x12	24"
W	41	W	1	12x12	24"
W	42	W	1	12x12	24"
W	43	W	1	12x12	24"
W	44	W	1	12x12	24"
W	45	W	1	12x12	24"
W	46	W	1	12x12	24"
W	47	W	1	12x12	24"
W	48	W	1	12x12	24"
W	49	W	1	12x12	24"
W	50	W	1	12x12	24"
W	51	W	1	12x12	24"
W	52	W	1	12x12	24"
W	53	W	1	12x12	24"
W	54	W	1	12x12	24"
W	55	W	1	12x12	24"
W	56	W	1	12x12	24"
W	57	W	1	12x12	24"
W	58	W	1	12x12	24"
W	59	W	1	12x12	24"
W	60	W	1	12x12	24"
W	61	W	1	12x12	24"
W	62	W	1	12x12	24"
W	63	W	1	12x12	24"
W	64	W	1	12x12	24"
W	65	W	1	12x12	24"
W	66	W	1	12x12	24"
W	67	W	1	12x12	24"
W	68	W	1	12x12	24"
W	69	W	1	12x12	24"
W	70	W	1	12x12	24"
W	71	W	1	12x12	24"
W	72	W	1	12x12	24"
W	73	W	1	12x12	24"
W	74	W	1	12x12	24"
W	75	W	1	12x12	24"
W	76	W	1	12x12	24"
W	77	W	1	12x12	24"
W	78	W	1	12x12	24"
W	79	W	1	12x12	24"
W	80	W	1	12x12	24"
W	81	W	1	12x12	24"
W	82	W	1	12x12	24"
W	83	W	1	12x12	24"
W	84	W	1	12x12	24"
W	85	W	1	12x12	24"
W	86	W	1	12x12	24"
W	87	W	1	12x12	24"
W	88	W	1	12x12	24"
W	89	W	1	12x12	24"
W	90	W	1	12x12	24"
W	91	W	1	12x12	24"
W	92	W	1	12x12	24"
W	93	W	1	12x12	24"
W	94	W	1	12x12	24"
W	95	W	1	12x12	24"
W	96	W	1	12x12	24"
W	97	W	1	12x12	24"

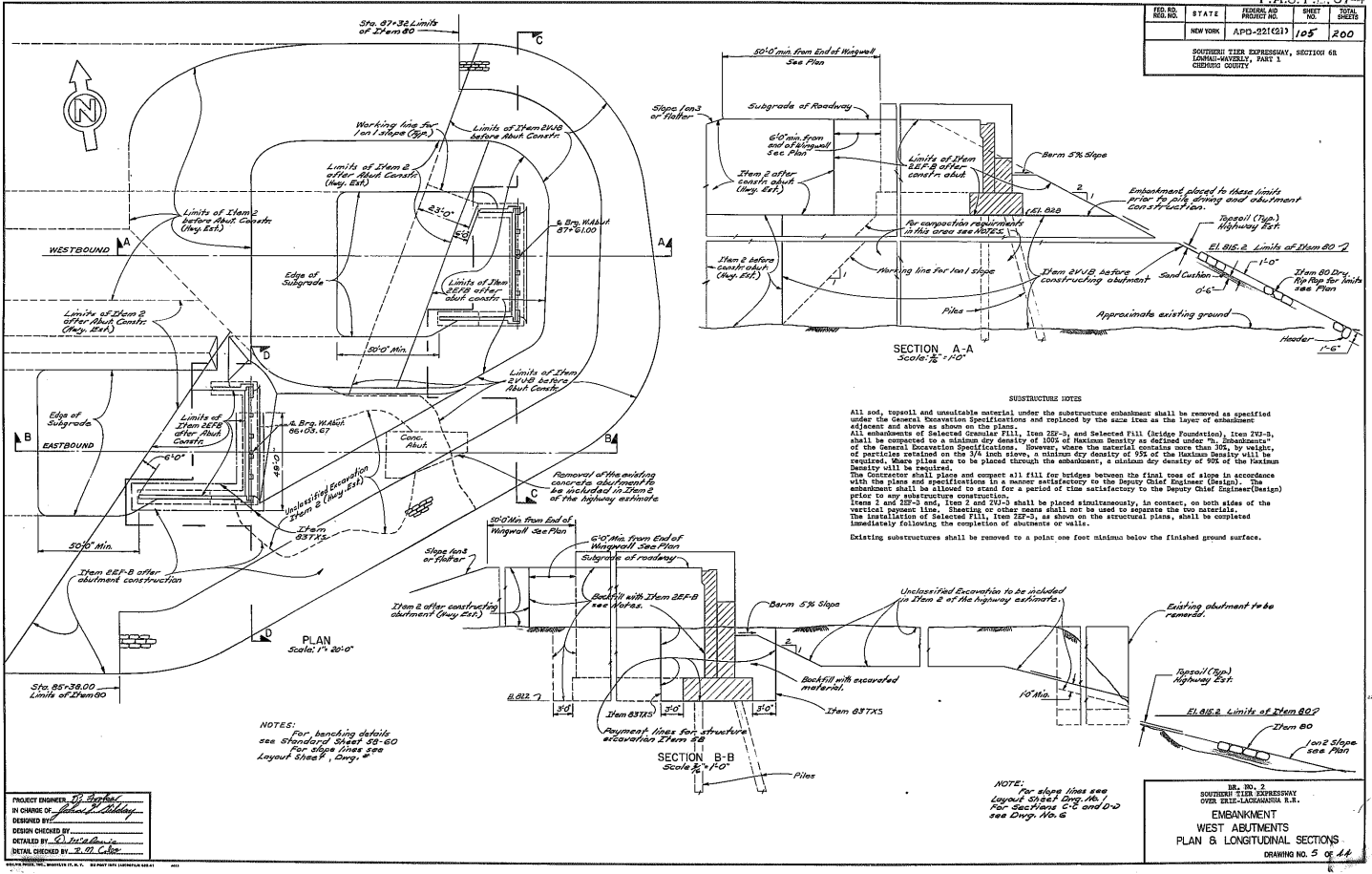
PROJECT ENGINEER: [Signature]
 IN CHARGE OF: [Signature]
 DESIGN CHECKED BY: [Signature]
 DETAIL CHECKED BY: [Signature]

SCALE: 1" = 20'
 DRAWING NO. 67-4A



FED. PROJ. NO.	STATE	CONTRACT NO.	SHEET NO.	TOTAL SHEETS
	NEW YORK	APD-221(21)	105	200

SOUTHERN TIER EXPRESSWAY, SECTION 68
LONGA-WAVERLY, PART 1
CROSSING SOUTH



SUBSTRUCTURE NOTES

All soil, topsoil and unsuitable material under the substructure embankment shall be removed as specified under the General Excavation Specifications and replaced by the same item as the layer of embankment adjacent and above as shown on the plans.

All embankments of Selected Granular Fill, Item 2EP-3, and Selected Fill (Surface Foundation), Item 2EP-3, shall be compacted to a minimum dry density of 100% of Maximum Density as defined under "Standard" of the General Excavation Specifications. However, where the material contains more than 30% by weight of particles retained on the 1/4 inch sieve, a minimum dry density of 95% of the Maximum Density will be required. These piles are to be placed through the embankment, a minimum dry density of 95% of the Maximum Density will be required.

The Contractor shall place and compact all fill for buttress between the final toes of slope in accordance with the plans and specifications in a manner satisfactory to the Deputy Chief Engineer (Design). The embankment shall be allowed to stand for a period of time satisfactory to the Deputy Chief Engineer (Design) prior to any substructure construction.

Items 2 and 2EP-3 and Item 2 and 2EP-3 shall be placed simultaneously, in contact, on both sides of the vertical support line. Spacing or other means shall not be used to separate the two materials.

The installation of Selected Fill, Item 2EP-3, as shown on the structural plans, shall be completed immediately following the completion of abutment or wall.

Existing substructures shall be removed to a point one foot minimum below the finished ground surface.

NOTES:

For banking details see General Specifications 88-80

For slope lines see Layout Sheet C, Dwg. 2

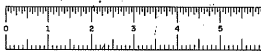
NOTE:

For slope lines see Layout Sheet Dwg. 2

For Sections C-C and D-D see Dwg. 105-2

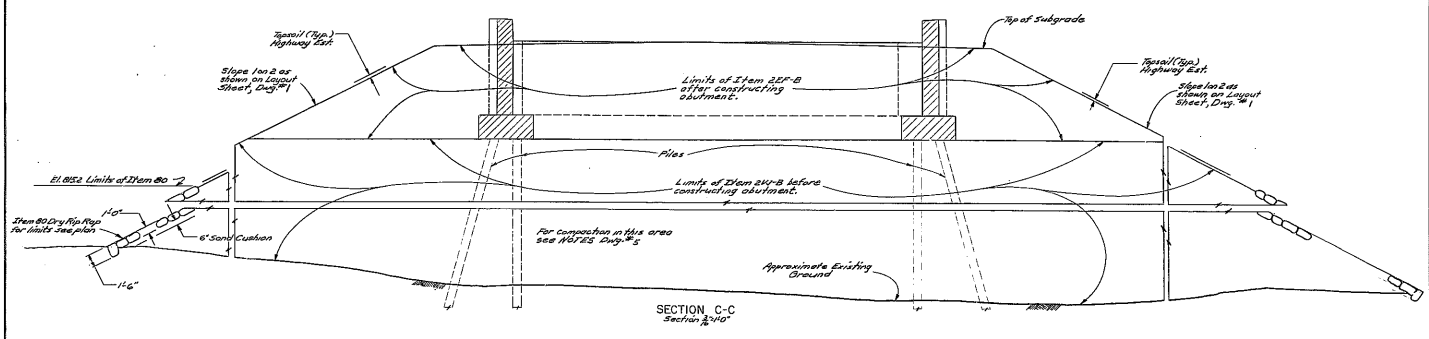
PROJECT ENGINEER: *J. J. [Signature]*
 IN CHARGE OF: *J. J. [Signature]*
 DESIGNED BY: *J. J. [Signature]*
 CHECKED BY: *J. J. [Signature]*
 DETAIL CHECKED BY: *J. J. [Signature]*
 DETAIL CHECKED BY: *J. J. [Signature]*

SR. NO. 2
 SOUTHERN TIER EXPRESSWAY
 OVER THE LONGA-WAVERLY R.R.
 EMBANKMENT
 WEST ABUTMENTS
 PLAN & LONGITUDINAL SECTIONS
 DRAWING NO. 5 OF 14

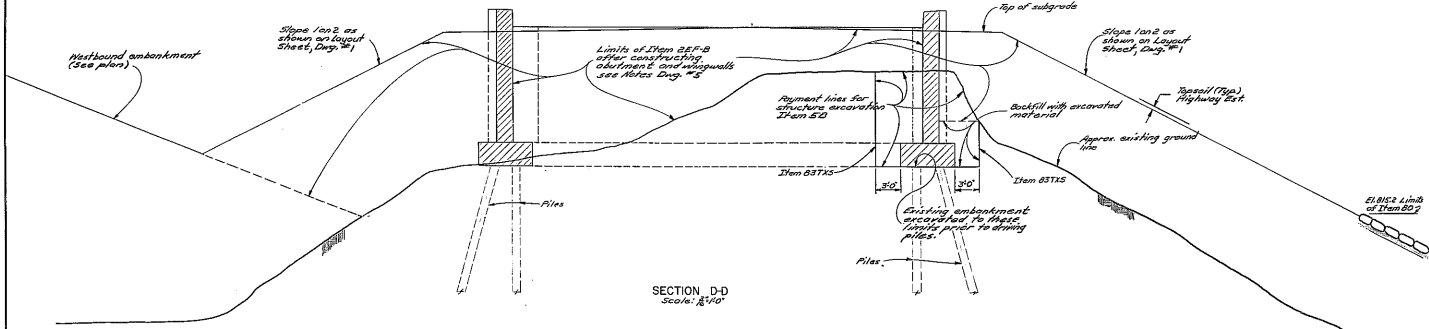


FED. NO.	STATE	PROJECT NO.	SHEET NO.	TOTAL SHEETS
	NEW YORK	APD-521(2)1	106	200

SOUTHERN TIER EXPRESSWAY, SECTION 6A
 LONG-ISLAND-NORFOLK, PART 1
 CROTON COUNTY



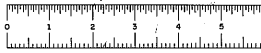
SECTION C-C
Scale: 1/4" = 10'



SECTION D-D
Scale: 1/4" = 10'

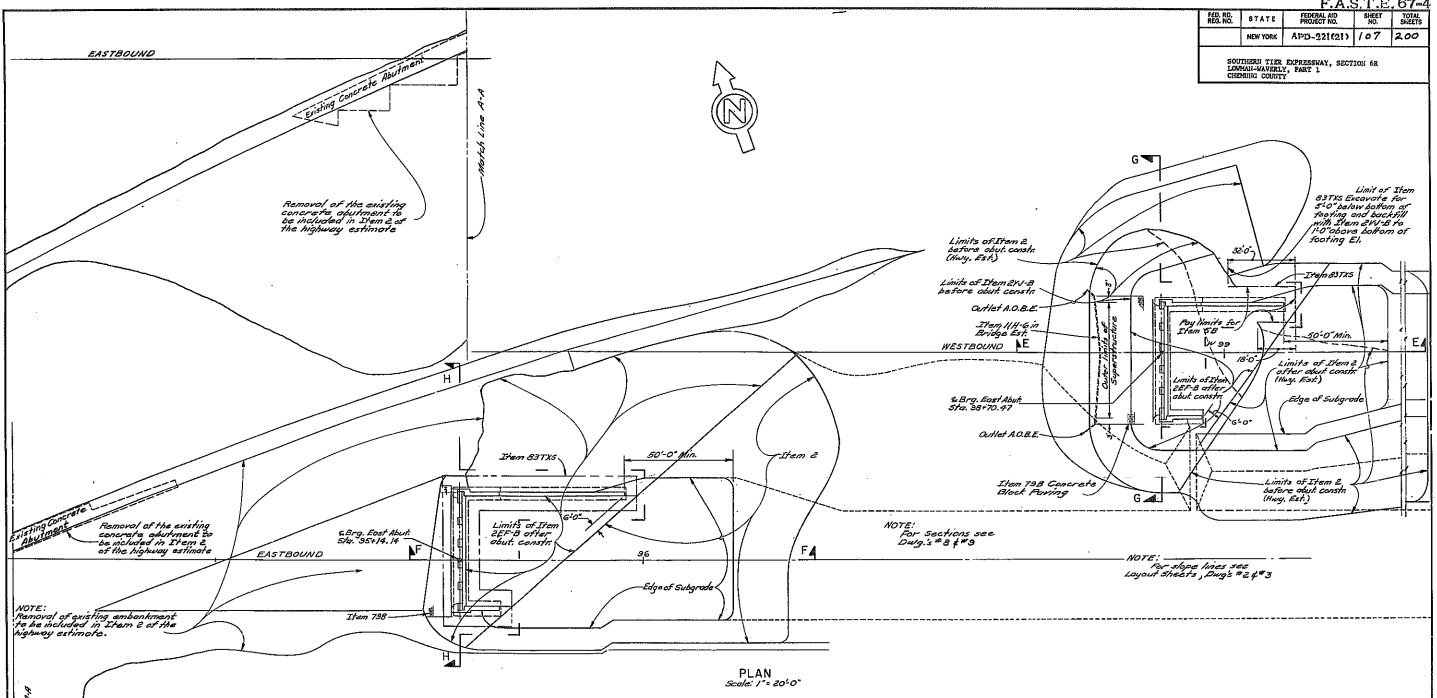
PROJECT ENGINEER: *R. J. [Signature]*
 IN CHARGE OF: *[Signature]*
 DESIGNED BY: *[Signature]*
 DESIGN CHECKED BY: *[Signature]*
 DETAIL CHECKED BY: *[Signature]*

SHEET NO. 2
 SOUTHERN TIER EXPRESSWAY
 OVER THE SACANDAGA R.R.
 EMBANKMENT
 WEST ABUTMENTS
 TRANSVERSE SECTIONS
 DRAWING NO. 6 OF 11



FED. PROJ. NO.	STATE	FEDERAL AID PROJ. NO.	SHEET NO.	TOTAL SHEETS
	NEW YORK	APD-521(21)	107	200

SOUTHERN FIER EXPRESSWAY, SECTION 68
LONG-ISLAND RAILWAY, PART 1
CROTON COUNTY



PLAN
Scale: 1" = 20'-0"

NOTE:
For benching details see
Standard Sheet SB-60

SUBSTRUCTURE NOTES

All sod, topsoil and unsuitable material under the substructure embankment shall be removed as specified under the General Excavation Specifications and replaced by the same item as the layer of embankment adjacent and shown as shown on the plans.

All embankments of Selected Granular Fill, Item 2P-2, and Selected Fill (Bridge Foundation), Item 2VJ-3, shall be compacted to a minimum dry density of 100% of Maximum Density as defined under "Compaction" of the General Excavation Specifications. However, where the material contains more than 30% by weight of particles retained on the 3/4 inch sieve, a minimum dry density of 95% of the Maximum Density will be required.

The Contractor shall place and compact all fill for bridges between the final case of abutment in accordance with the plans and specifications in a manner satisfactory to the Deputy Chief Engineer (Design). The embankment shall be allowed to stand for a period of time satisfactory to the Deputy Chief Engineer (Design) prior to any substructure construction.

Items 2 and 2P-2 and Item 3 and 3P-3 shall be placed simultaneously, in contact, on both sides of the vertical payment line. Sheeting or other means shall not be used to separate the two materials.

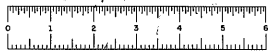
The installation of selected fill, Item 2P-2, as shown on the structure plans, shall be completed immediately following the completion of abutments or walls.

Selecting substructure shall be removed to a point one foot minimum below the finished ground surface.

All unsuitable material shall be removed and backfilled with compacted Item 2VJ-3 as ordered by the Engineer. If the depth of the unsuitable material exceeds twice the indicated depth shown on these plans the Deputy Chief Engineer (Design) must be consulted before proceeding with any work.

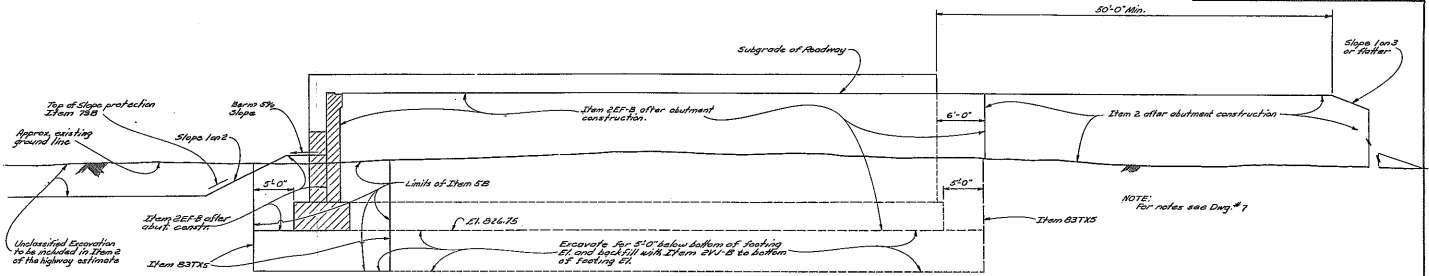
PROJECT ENGINEER: *[Signature]*
 IN CHARGE OF: *[Signature]*
 DESIGNED BY: *[Signature]*
 CHECKED BY: *[Signature]*
 SPECIAL ORDERED BY: *[Signature]*

SR. NO. 2
 SOUTHERN FIER EXPRESSWAY
 OVER THE LONG-ISLAND R.R.
 EMBANKMENT
 EAST ABUTMENTS
 PLAN
 DRAWING NO. 7 OF 44

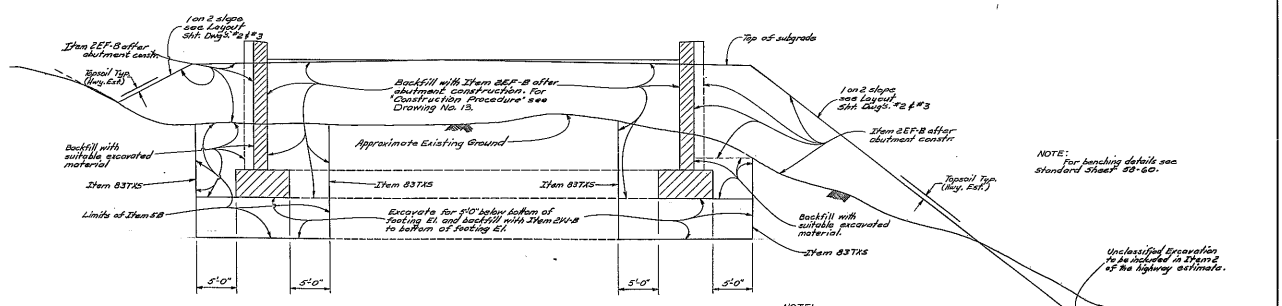


REG. NO.	STATE	REGION AND PROJECT NO.	SHEET NO.	TOTAL SHEETS
	NEW YORK	APD-211(21)	108	200

SOUTHERN RISE EXPRESSWAY, SECTION 6A
LONGHUB-HAYVELL, PART 1
CENESSE COUNTY



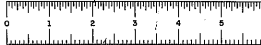
SECTION F-F
Scale: 1/4" = 1'-0"



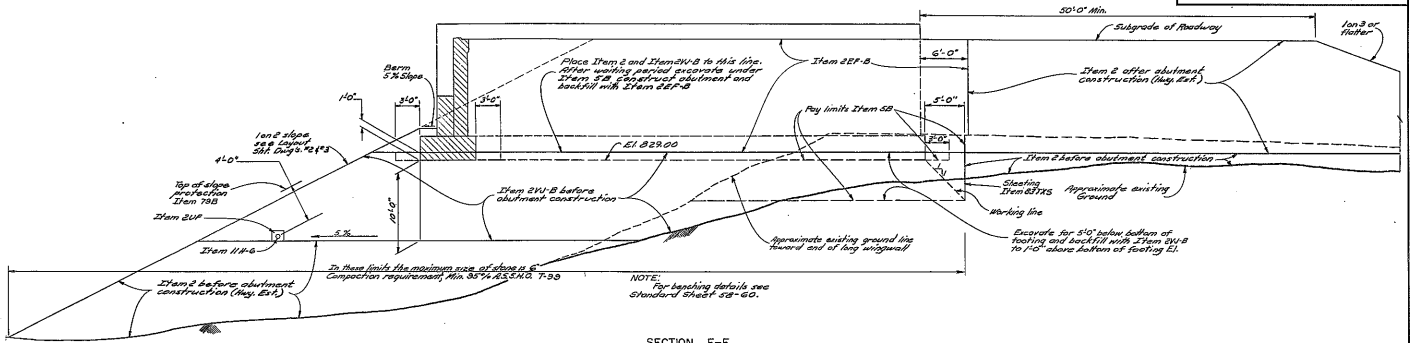
SECTION H-H
Scale: 1/4" = 1'-0"

PROJECT ENGINEER: P. J. Kelly
 IN CHARGE OF: John P. Kelly
 DESIGN CHECKED BY: _____
 DESIGN CHECKED BY: P. J. Kelly
 DETAIL CHECKED BY: P. M. Kelly

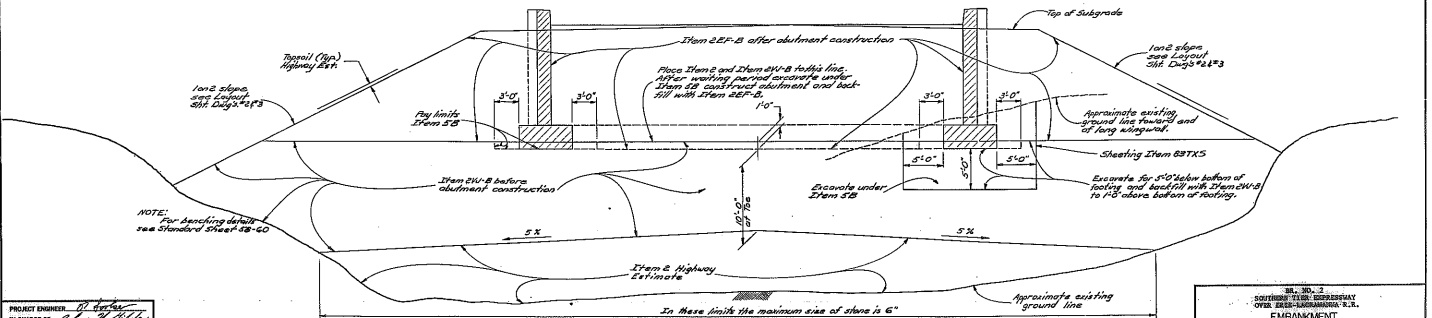
EMBANKMENT
 EASTBOUND EAST ABUTMENT
 SECTIONS
 DRAWING NO. 8 OF 44



F.A.S.T.E. 67-4				
NO. OF SHEETS	STATE	FEDERAL AID PROJECT NO.	SHEET NO.	TOTAL SHEETS
	NEW YORK	APD-221(21)	09	200
SOUTHERN TIER EXPRESSWAY, SECTION 6R LOUISIANA-MARYLAND, PART 1 WESTBOWN COUNTY				



SECTION E-E
Scale: 3/8"=1'-0"



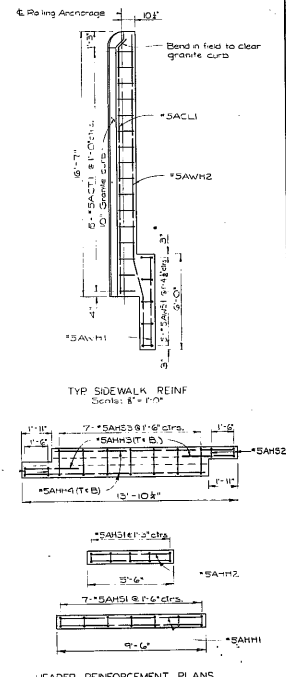
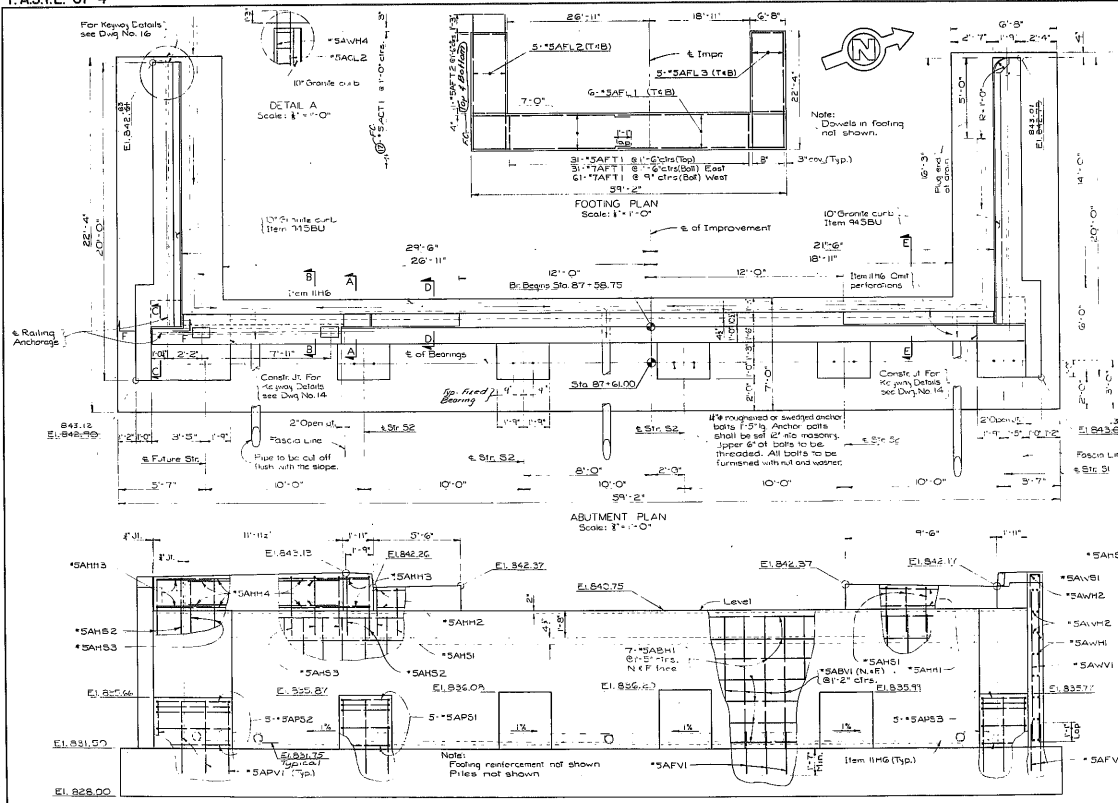
In these limits the maximum size of stone is 6"
Compaction requirements - Min. of 95% A.S.T.M. D.1557, 99

SECTION G-G
Scale: 3/8"=1'-0"

PROJECT ENGINEER: *[Signature]*
 IN CHARGE OF: *[Signature]*
 DESIGNED BY: *[Signature]*
 CHECKED BY: *[Signature]*
 DETAIL CHECKED BY: *[Signature]*

NO. 2
 SOUTHERN TIER EXPRESSWAY
 WESTBOWN COUNTY
 EMBANKMENT
 WESTBOWN EAST ABUTMENT
 SECTIONS
 DRAWING NO. 9 OF 11

FED. RD. DIST. NO.	STATE	FEDERAL AID PROJECT NO.	SHEET NO.	TOTAL SHEETS
	NEW YORK	AD-271(21)	110	199
SOUTHERN TIER EXPRESSWAY, SECTION 6A COMMUNWELL, PART 1 ORISKANY COUNTY				



Notes:
For design purposes the pile load does not exceed 35 tons per pile.
The estimated length of Cast-in-Place Concrete piles *Per 85C, 80) F.C.* the westbound west Abutment is 65 ft.
(For Pile Plan see Dwg. No. 12) F.C.

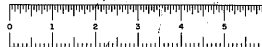
Notes:
Piles must be driven to a tip elevation no higher than E1.181 regardless of the difficulty of driving.
Built abutment and abutment is looking direction
Leave in place for one month prior to driving piles.

PROJECT ENGINEER: *[Signature]*
IN CHARGE OF: *[Signature]*
DESIGNED BY: *[Signature]*
DESIGN CHECKED BY: *[Signature]*
DETAIL CHECKED BY: *[Signature]*

ELEVATION
Scale: 1" = 1'-0"
REVISIONS
1. WINGWALL TOP ELEVATION

FIELD CHANGE SHEET

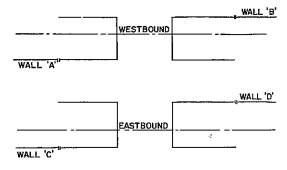
11/12/1991
SOUTHERN TIER EXPRESSWAY
OVER SILEX-LOGANVILLE R.R.
WESTBOUND
WEST ABUTMENT
DRAWING NO. 10 OF 11



F.A.S.T.E. 67-4

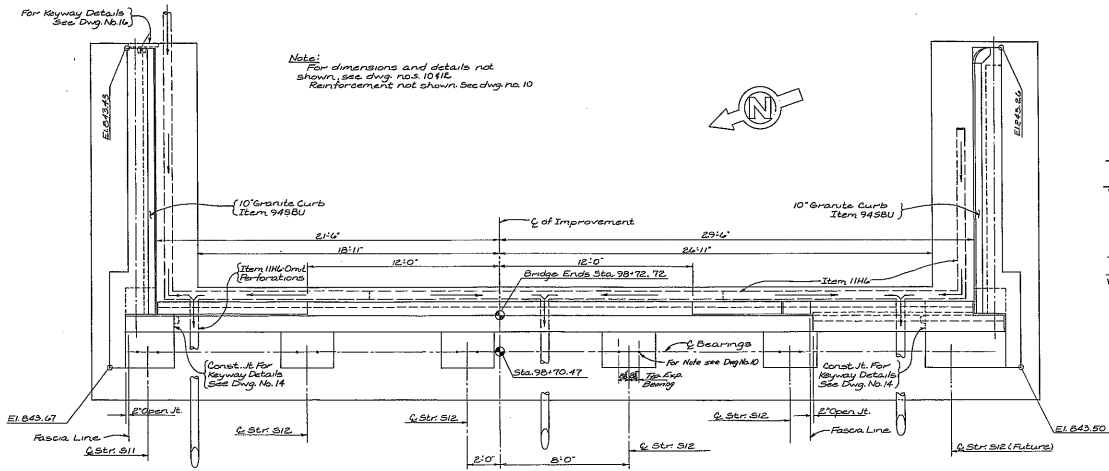
FED. AID DIST. NO.	STATE	FEDERAL AID PROJECT NO.	SHEET NO.	TOTAL SHEETS
	NEW YORK	AND-231(21)	111	200

SOUTHERN TIER EXPRESSWAY, SECTION 68
 DOWN-RAMP, PART 1
 COMMON COURSE

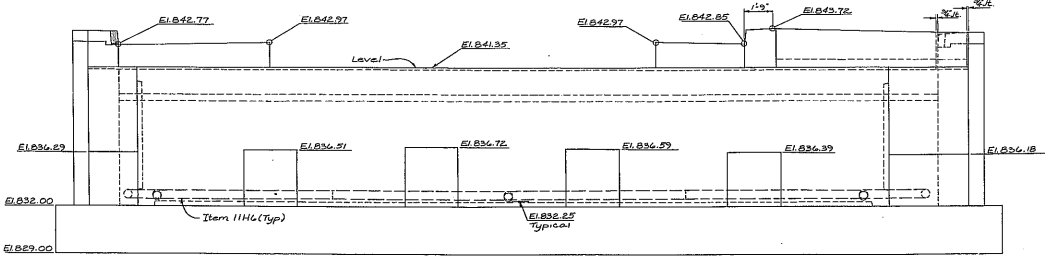


SCHEMATIC PLAN
 No Scale

Note:
 For dimensions and details not shown, see drawing nos. 10 & 11
 Reinforcement not shown. See drawing no. 10



PLAN
 Scale 1/8" = 1'-0"



ELEVATION
 Scale 1/8" = 1'-0"

Note:
 For details of Wall 'B' see drawing no. 16.

PROJECT ENGINEER: *J. J. [Signature]*
 IN CHARGE OF: *E. J. [Signature]*
 DESIGNED BY: *E. J. [Signature]*
 DESIGN CHECKED BY: *[Signature]*
 DETAIL CHECKED BY: *[Signature]*

Note:
 For design purposes the foundation pressures shall not exceed 2 1/2 tons per square foot;
 Build embankment to facing elevation.
 Wait one month before starting abutment construction

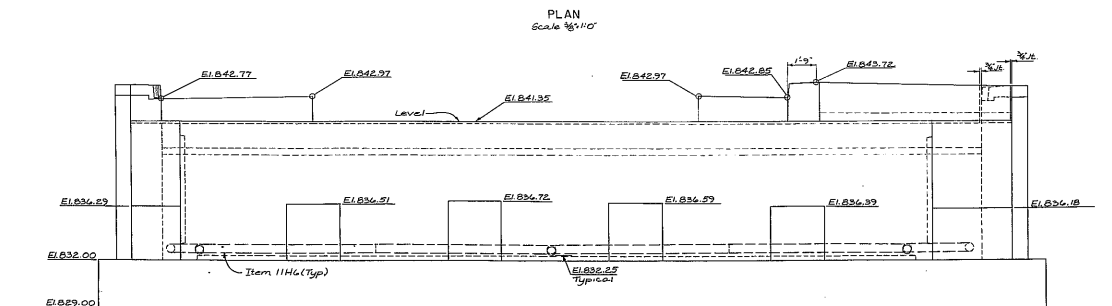
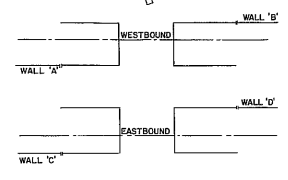
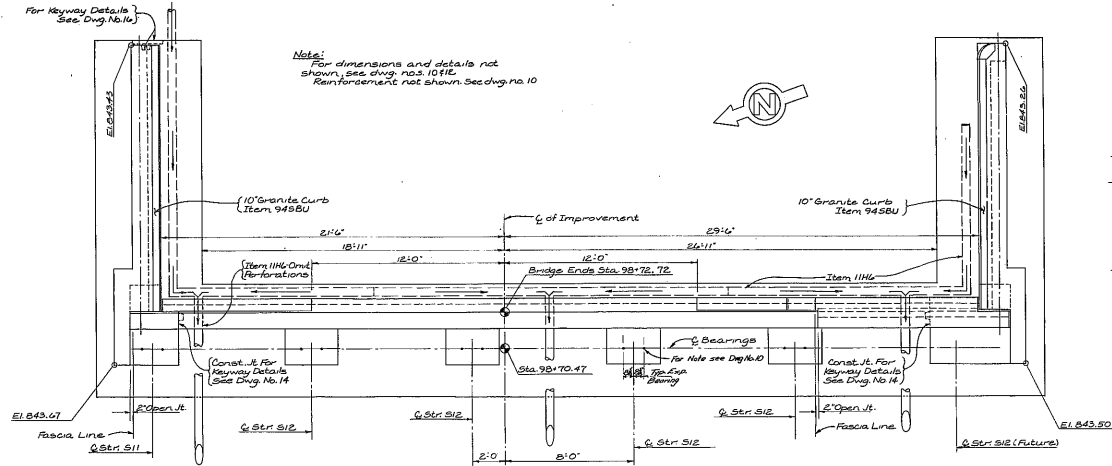
SHEET NO. 2
 SOUTHERN TIER EXPRESSWAY
 OVER EAST-LACKAWANNA R.R.
 WESTBOUND
 EAST ABUTMENT
 DRAWING NO. 11 OF 11

REPLACES AND SUCCEEDS THE FOLLOWING DRAWING NO. 11 OF 11



NO. NO.	STATE	PROJECT NO.	SHEET NO.	TOTAL SHEETS
	NEW YORK	APD-211(21)	111-F1	100

SOUTHERN TIER EXPRESSWAY, SECTION 02
LANHAM-GATELY, PART 1
COLUMBIA COUNTY



FIELD CHANGE SHEET

Note: For details of Wall 'B' see dwg. no. 14.

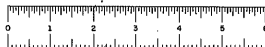
PROJECT ENGINEER: [Signature]
 IN CHARGE OF: [Signature]
 DESIGN CHECKED BY: [Signature]
 REVIEWED BY: [Signature]
 DESIGN CHECKED BY: [Signature]

ELEVATION Scale 3/8"=1'-0"

Note: For design purposes the foundation pressure does not exceed 2 1/2 tons per square foot. Build embankment to footing elevation. Wait one month before starting abutment construction.

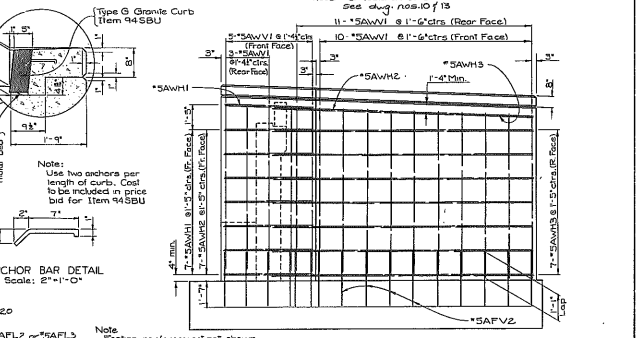
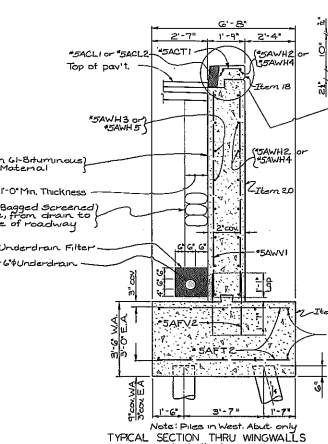
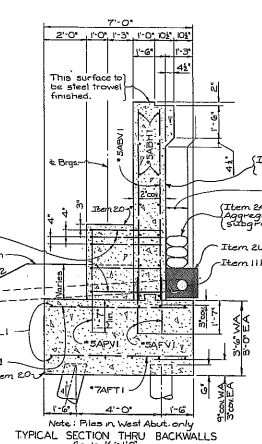
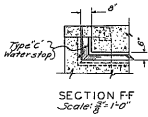
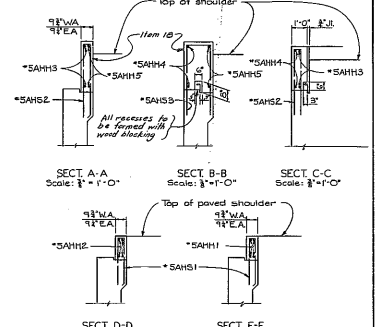
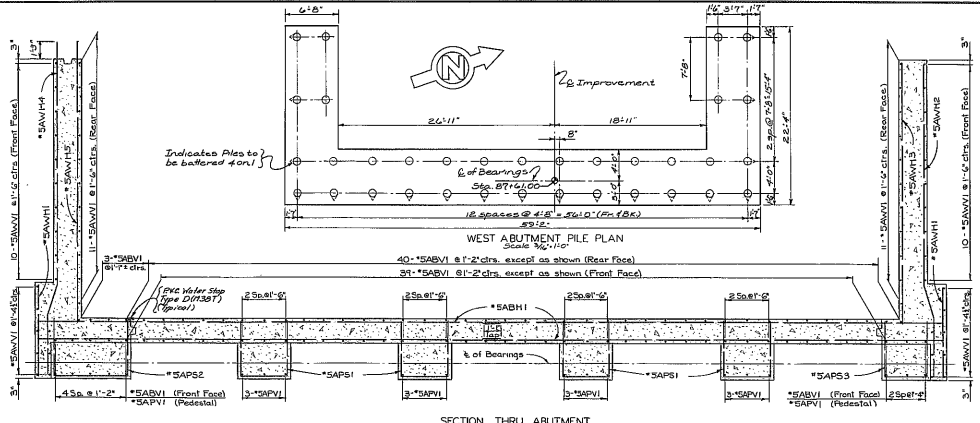
APPROVED
 CIVIL 29 1957
 [Signature]
 State Civil Engineer (Rec'd)

NO. 2
 SOUTHERN TIER EXPRESSWAY
 OVER ELLE-LANHAM T.J.S.
 WESTBOUND
 EAST ABUTMENT
 DRAWING NO. 11 OF 14



PROJ. NO.	STATE	FEDERAL AID PROJECT NO.	SHEET NO.	TOTAL SHEETS
NEW YORK	APD-271(11)		112	200

SOUTHERN TIER EXPRESSWAY, SECTION 08
 LAMON WATERLY, PART 1
 CROSSING CANYON



PROJECT ENGINEER: *[Signature]*
 IN CHARGE OF: *[Signature]*
 DESIGNED BY: *[Signature]*
 DESIGN CHECKED BY: *[Signature]*
 DETAIL CHECKED BY: *[Signature]*

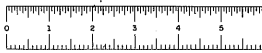
Note: Piles in West Abut. only

Note: Piles in West Abut. only

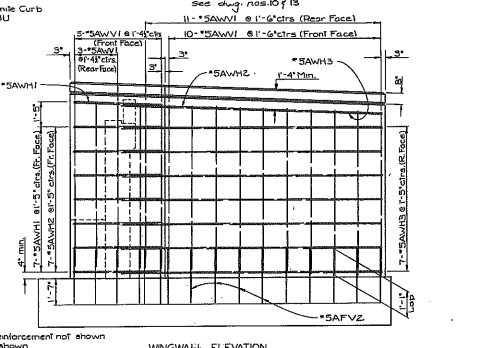
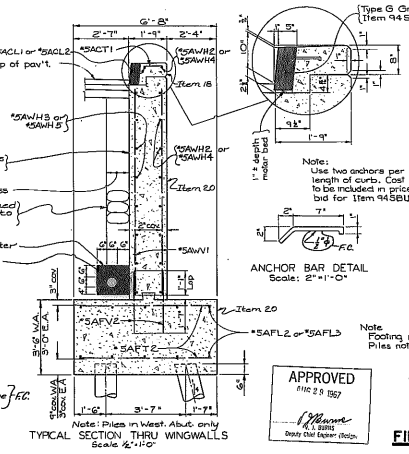
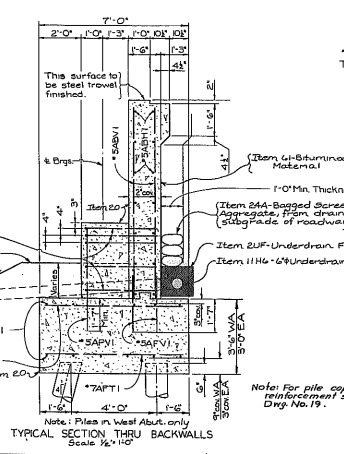
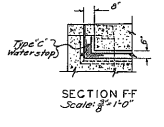
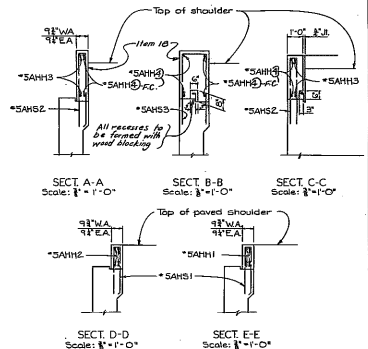
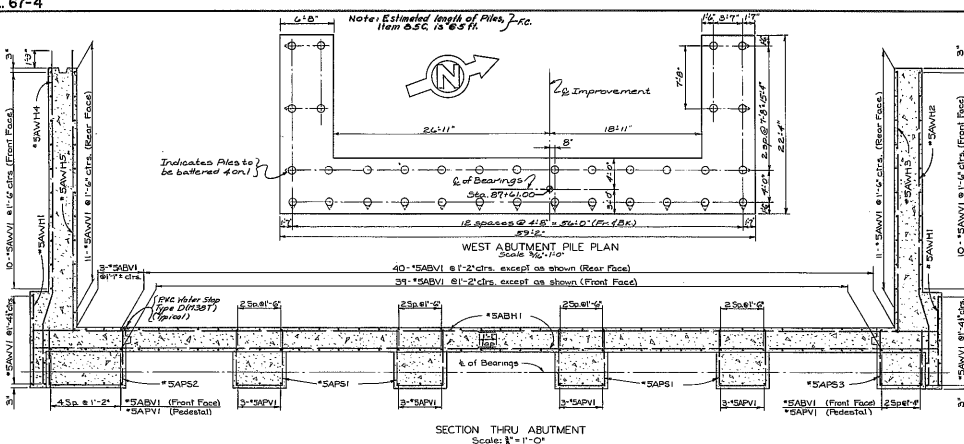
Note: Footing reinforcement not shown
 Piles not shown

Note: For Waterstop and Joint Details see Div. No. 3B.

BR. NO. 3
 SOUTHERN TIER EXPRESSWAY
 OVER 2616-LAGRANVILLE R.R.
 WESTBOUND
 EAST & WEST ABUTMENT DETAILS
 DRAWING NO. 12 OF 14



FD. NO.	STATE	FEDERAL AID PROJECT NO.	SHEET NO.	TOTAL SHEETS
APD-221(21)	MD		112	120
SOUTHVIEW TIER ROADSIDEWAY, SECTION 68 LOANS, WATER, PART 1 CARMON COUNTY				



PROJECT ENGINEER: *[Signature]*
 IN CHARGE OF: *[Signature]*
 DESIGNED BY: *[Signature]*
 CHECKED BY: *[Signature]*
 FIELD CHECKED BY: *[Signature]*

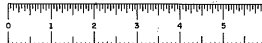
Note: Piles in West Abut. only
 Scale: 1/2" = 1'-0"

Note: Piles in West Abut. only
 Scale: 1/2" = 1'-0"

APPROVED
 AUG 28 1967
[Signature]
 State Engineer

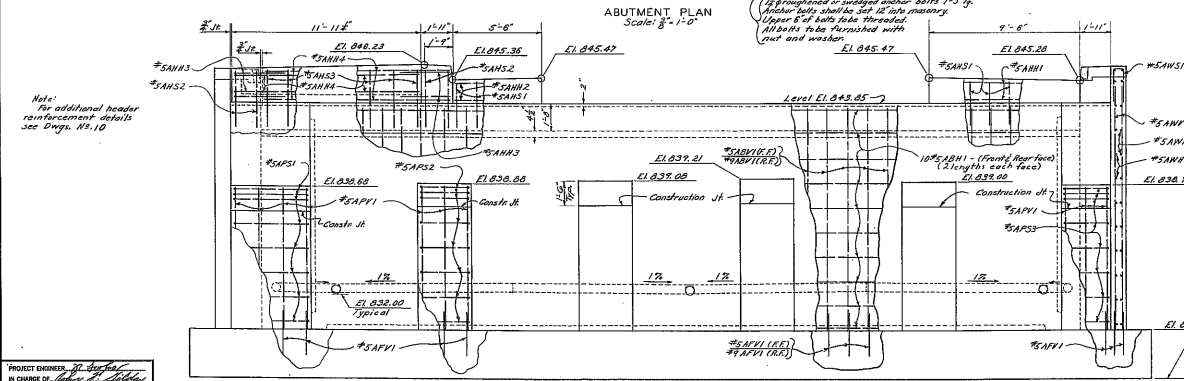
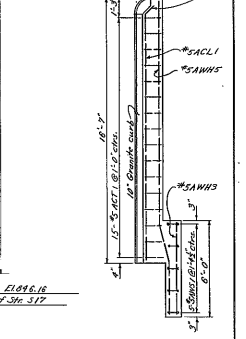
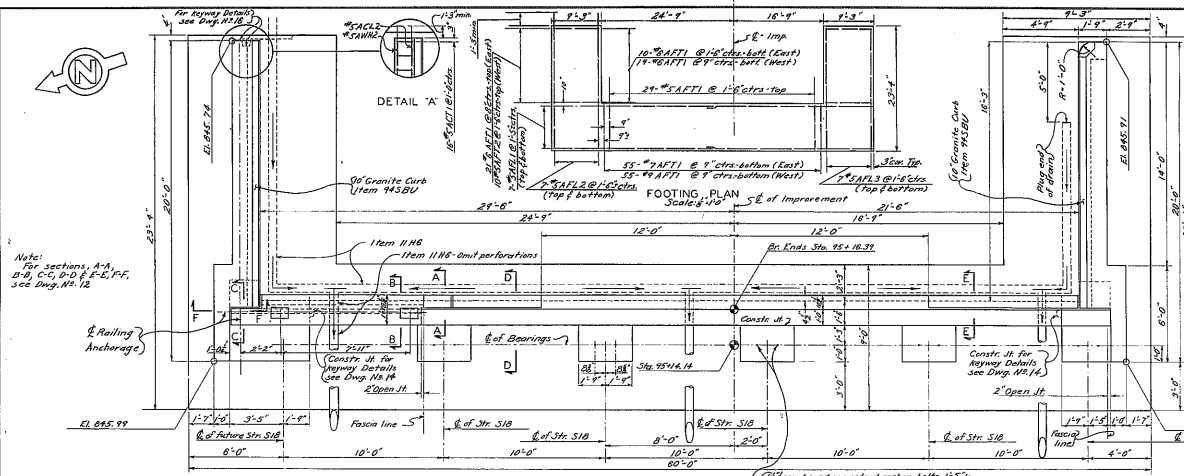
Note: For Waterstop and Joint Details see Dwg. No. 58.
FIELD CHANGE SHEET

BL. NO. 2
 SOUTHWEST TIER ROADSIDEWAY
 OVER ERIE-LAGUNA R.R.
 WESTBOUND
 EAST & WEST ABUTMENT DETAILS
 DRAWING NO. 12



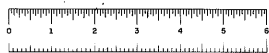
FAST E 87-4			
NO. 10	STATE	FEDERAL AID PROJECT NO.	SHEET NO.
	NEW YORK	APPD-231(21)	113
SECTION TITLE, HIGHWAY, SECTION OR LOCALITY, PART 1		CHESTER COUNTY	

Bend in field to clear granite curb in south wingwall only. See Detail 'A'.



PROJECT ENGINEER: [Signature]
 IN CHARGE OF: [Signature]
 DESIGNED BY: [Signature]
 DESIGN CHECKED BY: [Signature]
 DETAILS CHECKED BY: [Signature]

SR. NO. 2
 SOUTHERN TIER HIGHWAY
 OVER TELLINGHAM, E.L.
 EASTBOUND
 EAST ABUTMENT
 DRAWING NO. 13 OF 14



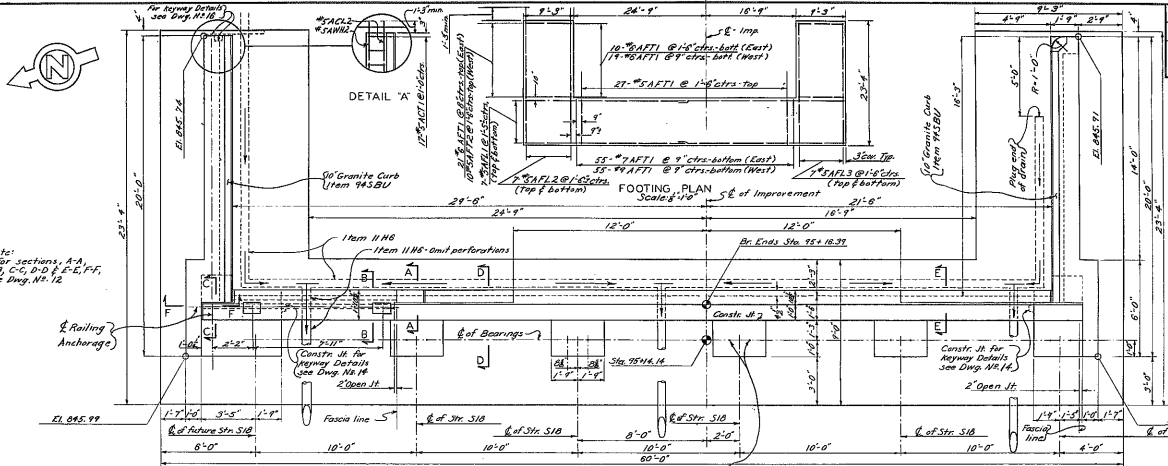
FAST.E.67-4

FAST.E.67-4

FED. RD. DIST. NO.	STATE	FEDERAL AID PROJECT NO.	SHEET NO.	TOTAL SHEETS
	NEW YORK	APD 231(21)	113-F	200

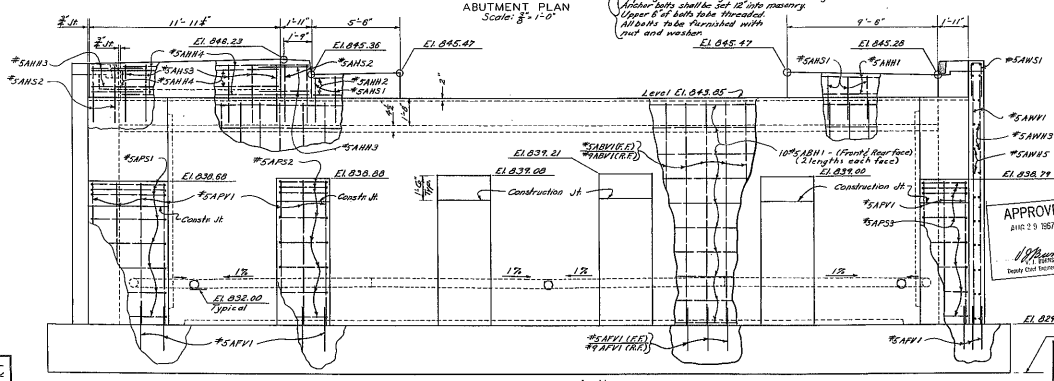
SOUTH TIER EXPRESSWAY, SECTION 6R
LANARK-HALETHORPE PART 1
CHENING COUNTY

Send in field to clear granite curb in south wing wall only. See Detail 'A'.



Note: For sections, A-A, B-B, C-C, D-D, E-E, F-F, see Dwg. No. 12.

ABUTMENT PLAN Scale: 3/4"=1'-0"



TYR SIDEWALK REIN Scale: 3/4"=1'-0"

Construction Procedure - Build abutment up to top of Form 24-B except for final pedestal pour. Backfill to subgrade elevation. Wash one month. Pour pedestals to final elevation.

Note: For design purposes the foundation pressure does not exceed 22 tons per square foot.

APPROVED
DATE: 2-9-1957
[Signature]

FIELD CHANGE SHEET

For water stop & joint details see Dwg. No. 5B.
For details of Wall 'D' see Dwg. No. 10.

PROJECT ENGINEER: [Signature]
IN CHARGE OF DESIGN: [Signature]
DESIGNED BY: [Signature]
DESIGN CHECKED BY: [Signature]
DETAILED BY: [Signature]
CHECKED BY: [Signature]

ELEVATION Scale: 3/4"=1'-0"

BR. NO. 2
SOUTH TIER EXPRESSWAY
OVER ELLE-LACKAWANNA R.R.
EASTBOUND
EAST ABUTMENT
DRAWING NO. 13 OF 44

FAST.E.67-4

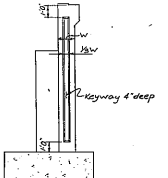
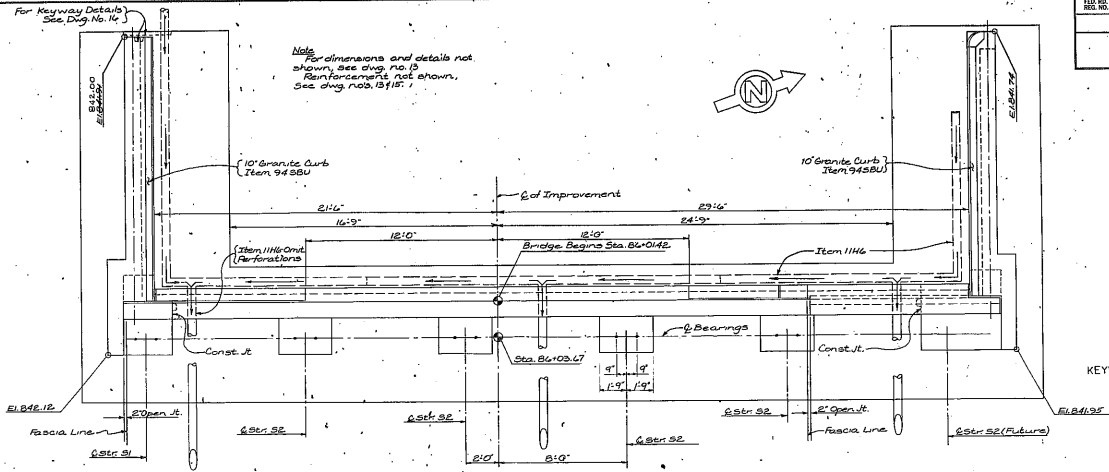
FAST.E.67-4

FED. RD. DIST. NO.	STATE	FEDERAL AID PROJECT NO.	SHEET NO.	TOTAL SHEETS
NEW YORK	100-211(21)	114R1	199	

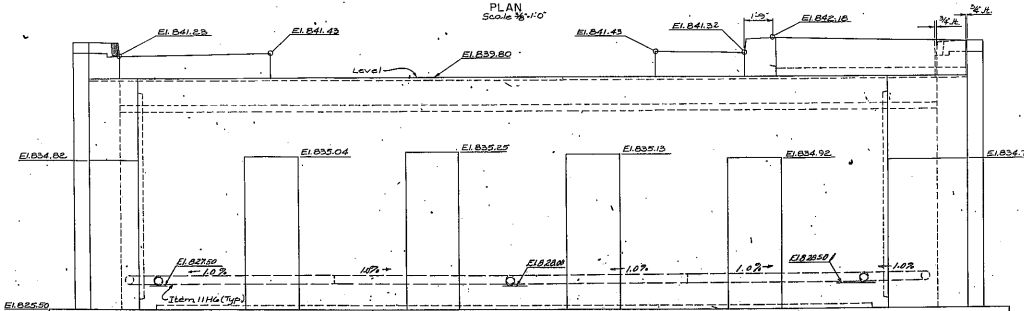
SECTION 1114 EXPANSION, SECTION 68
SOUTH-WESTLY, PART 1
CHENING COUNTY.

For Keyway Details See Dwg. No. 16

Note: For dimensions and details not shown, see dng. no. 15
Reinforcements not shown, see dng. no. 15/17.



KEYWAY DETAIL IN BACKWALL
Scale 1/4"=1'-0"



Note: For design purposes the pile load does not exceed 35 tons per pile. The estimated length of Cast-in-Place Concrete piles is 35 feet.
Piles must be driven to a 1/4" elevation no higher than EL 841.80 regardless of the difficulty to drive. Build abutment embankment to existing elevation. Mill one month prior to driving piles.

REVISIONS

1. TOP ELEVATION WINGWALL RT. W. END

Note: For details of wall 'C' see dng. no. 16

PROJECT ENGINEER: *[Signature]*
IN CHARGE OF: *[Signature]*
DESIGNED BY: *[Signature]*
DESIGN CHECKED BY: *[Signature]*
DETAILS CHECKED BY: *[Signature]*

EL 822.00

ELEVATION
Scale 1/8"=1'-0"

Note: Piles not shown. For layout see dng. no. 15

SECTION 1114 EXPANSION
OVER SELE-LEACHMAN R.R.
EASTBOUND
WEST ABUTMENT

DRAWING NO. 16 OF 24



F.A.S.T.E. 67-4

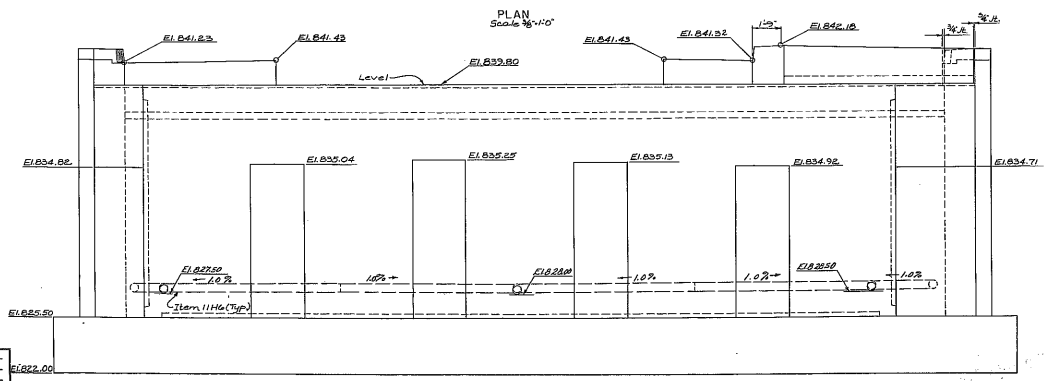
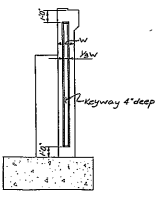
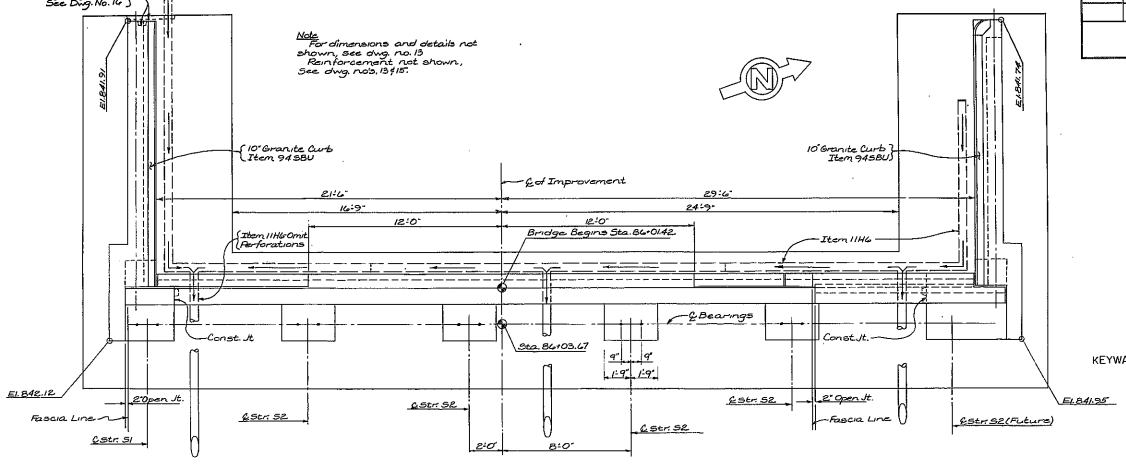
F.A.S.T.E. 67-4

NO. NO.	STATE	FEDERAL AID PROJECT NO.	SHEET NO.	TOTAL SHEETS
	NEW YORK	100-21(21)	114-11	200

SOUTHERN TIER EXPRESSWAY, SECTION 6R
 16000'-16000', PART 1
 CHEMUNG COUNTY

For Keyway Details See Div. No. 16

Note: For dimensions and details not shown, see div. no. 15. Reinforcement, not shown, see div. nos. 13 & 18.



Note: For design purposes the pile load does not exceed 25 tons per pile. The estimated length of Cast-in-Place Concrete piles is 35 feet. Piles must be driven to a tip elevation no higher than EL 293.00 regardless of the difficulty to drive. Build abutment embankment to final elevation. Wait one month prior to driving piles.

APPROVED
 11/15/87
 [Signature]

FIELD CHANGE SHEET

Note: For details of wall C see div. no. 16

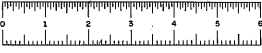
1-38-10-8
 SOUTHERN TIER EXPRESSWAY
 OVER CHEMUNG COUNTY
 EASTBOUND
 WEST ABUTMENT
 DRAWING NO. 16 OF 24

PROJECT ENGINEER: [Signature]
 IN CHARGE OF: [Signature]
 DESIGN CHECKED BY: [Signature]
 DETAILS BY: [Signature]
 INITIAL CHECKED BY: [Signature]

ELEVATION
 Scale 1/8"=1'-0"
 Note: Piles not shown for layout see div. no. 15

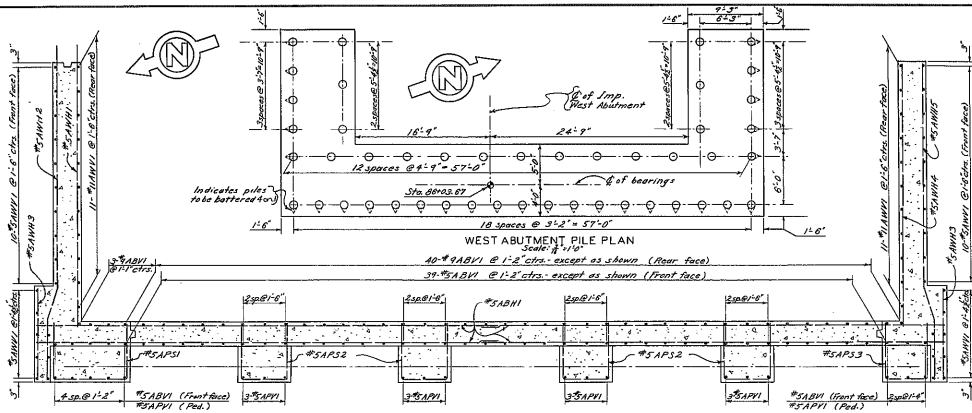
F.A.S.T.E. 67-4

F.A.S.T.E. 67-4

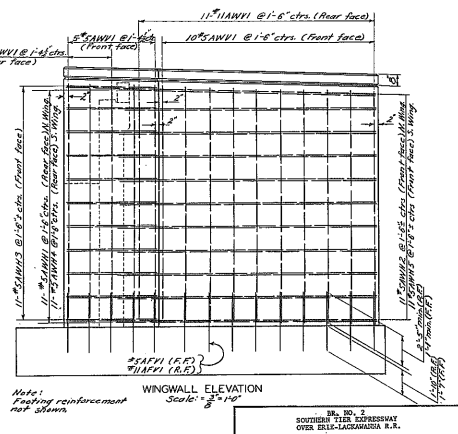
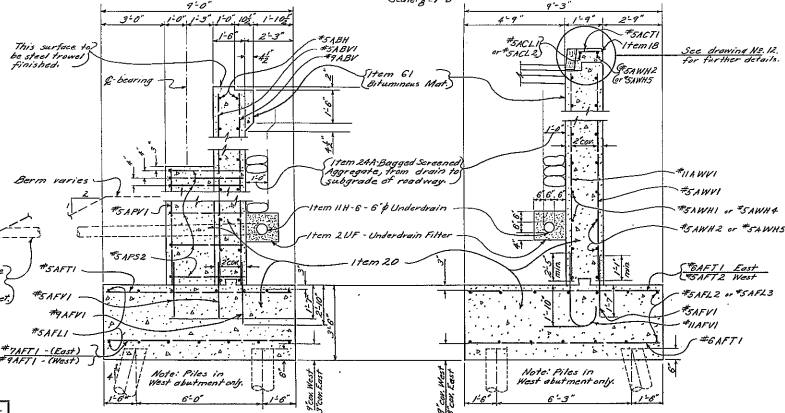


FED. PROJ. NO.	STATE	FEDERAL AID PROJECT NO.	SHEET NO.	TOTAL SHEETS
	NEW YORK	APD-221(C13)	115	200

SOUTHERN FIER EXPRESSWAY, SECTION OR LOCAL-MAINTENANCE, PART 1
COLUMBIAN COUNTY



SECTION THRU ABUTMENT
Scale: 3/8" = 1'-0"



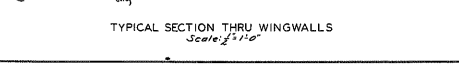
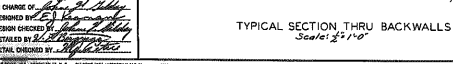
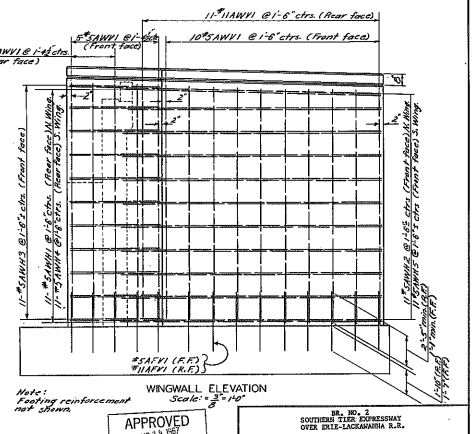
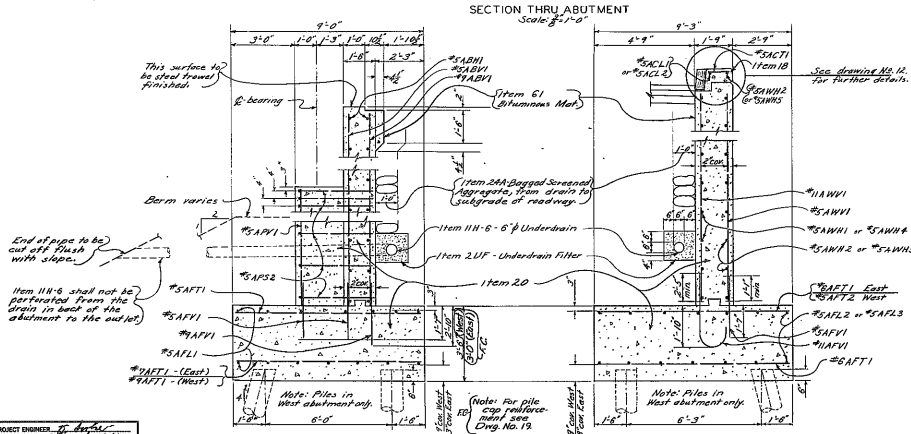
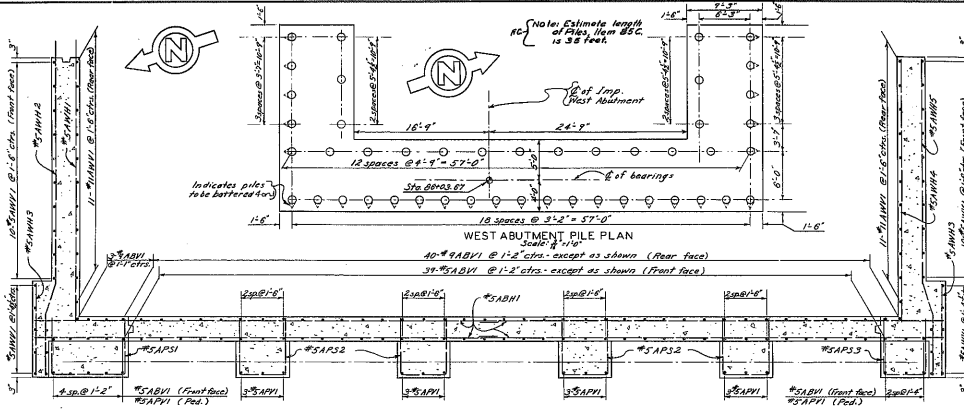
PROJECT ENGINEER: *[Signature]*
 IN CHARGE OF: *[Signature]*
 DESIGNED BY: *[Signature]*
 DESIGN CHECKED BY: *[Signature]*
 DETAIL CHECKED BY: *[Signature]*

DRG. NO. 2
 SOUTHERN FIER EXPRESSWAY
 OVER BULL-LANARSON RD. S.E.
 EASTBOUND
 EAST & WEST ABUTMENT DETAILS
 DRAWING NO. 15 OF 44

FED. RD. DIST. NO.	STATE	FEDERAL AID PROJECT NO.	SHEET NO.	TOTAL SHEETS
	NEW YORK	APD-231(213)	115/FI	200

SOUTHERN TIER INFRASTRUCTURE, SECTION 68
 LAMAR-HAVRELL, PART 1
 COLUMBIAN COUNTY

FIELD CHANGE SHEET



PROJECT ENGINEER: *[Signature]*
 IN CHARGE OF: *[Signature]*
 DESIGNED BY: *[Signature]*
 CHECKED BY: *[Signature]*
 DETAIL CHECKED BY: *[Signature]*
 SOCIAL CHECKED BY: *[Signature]*

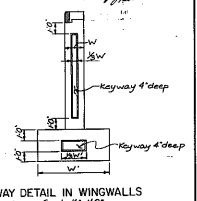
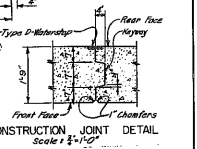
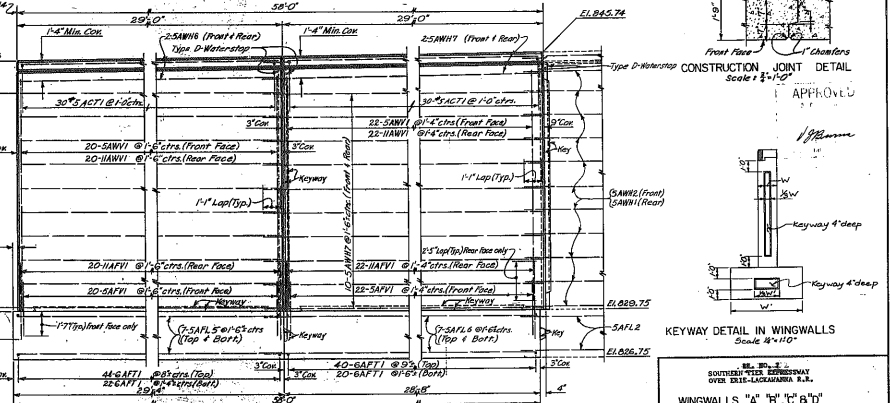
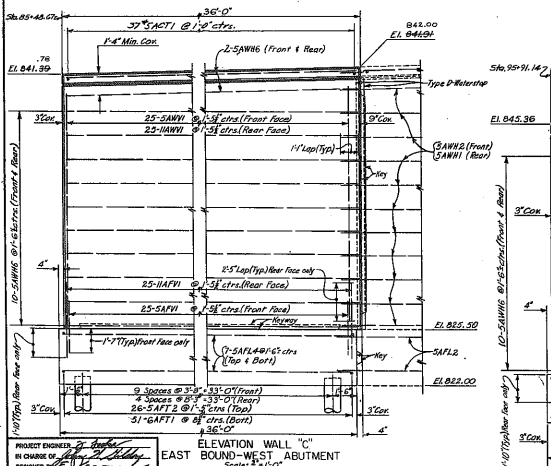
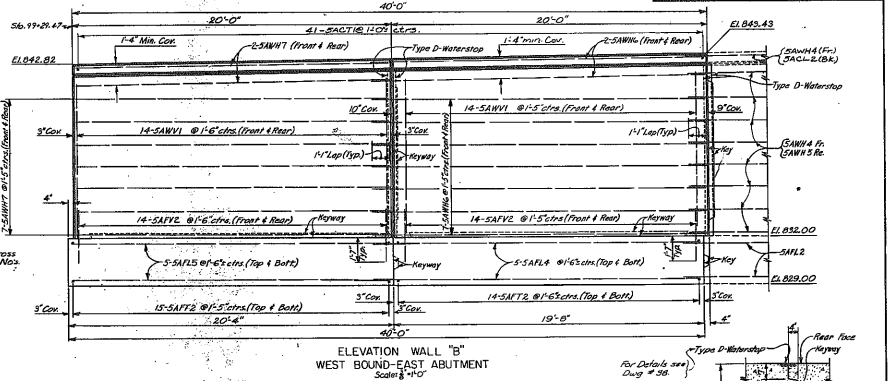
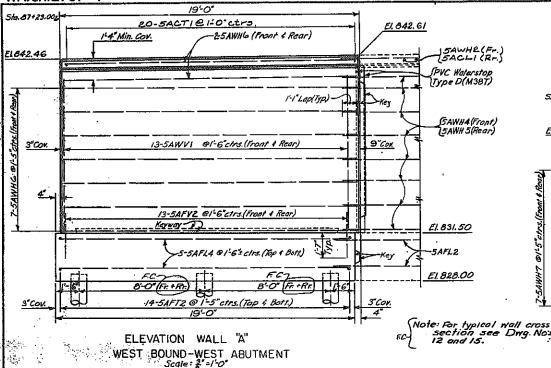
APPROVED
 AUG 29 1967
[Signature]
 DISPLAY DIST. LICENSE: 100479

DR. NO. 2
 SOUTHERN TIER INFRASTRUCTURE
 OVER 2633-BACKSQUARA N.E.
 EASTBOUND
 EAST & WEST ABUTMENT DETAILS
 DRAWING NO. 15 OF 26

FIELD CHANGE SHEET

REV. NO.	STATE	REGIONAL PROJ. NO.	SHEET NO.	TOTAL SHEETS
	NEW YORK	APD-211(13)	116	199

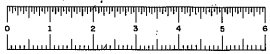
SOUTHERN TIER EXPRESSWAY, SECTION 68
LONGHILL-GATELY, PART 1
CONCRETE CURB



PROJECT ENGINEER: [Signature]
 IN CHARGE OF: [Signature]
 DESIGNER: [Signature]
 REGION CHECKED BY: [Signature]
 DETAIL CHECKED BY: [Signature]

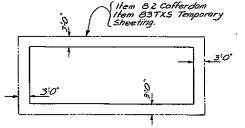
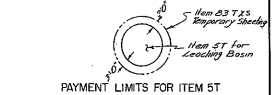
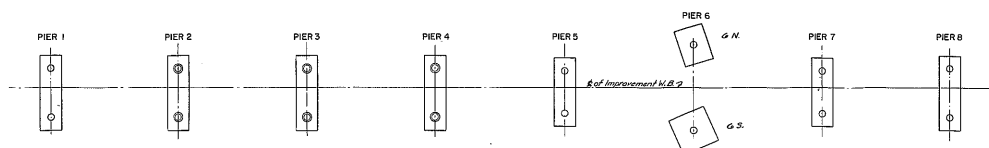
REVISIONS
 1. REVISION TO TOP ELEVATION WALL "C"

NO. 67-4
 SOUTHERN TIER EXPRESSWAY
 OVER ELIZABETH R.R.
 WINGWALLS "A", "B", "C" & "D"
 DRAWING NO. 16 OF 44
 F.A.S.T.E. 67-4

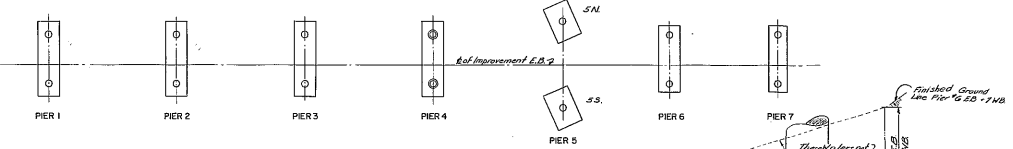


FED. NO.	STATE	FEDERAL AID PROJECT NO.	SHEET NO.	TOTAL SHEETS
	NEW YORK	APD-23(21)	117	200

SOUTHERN TIER EXPRESSWAY, SECTION 6A
LONG-ISLAND, TOWN 1
CELESTINE COUNTY



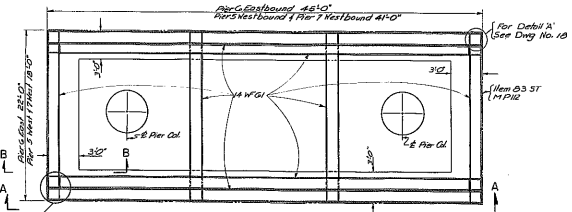
Note: Grade to finished ground before placing 83TX or 83ST.



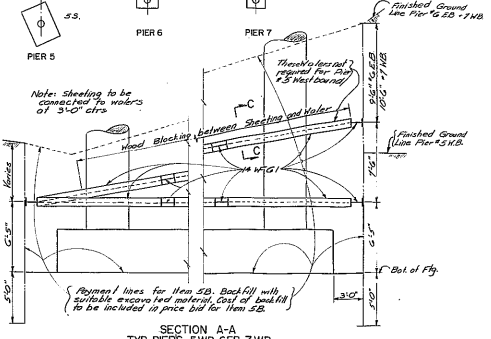
SCHEMATIC PIER LAYOUT
Not to Scale

Location	WESTBOUND		EASTBOUND	
	SHEETING EST. PILE	MIN. PILE	SHEETING EST. PILE	MIN. PILE
Pier No. 1	83T15	20'	83T15	20'
2	82	30'	83T15	20'
3	82	20'	83T15	20'
4	82	20'	83T15	20'
5	83ST	20'	83T15	20'
6	83ST	20'	83T15	20'
7	83ST	20'	83T15	20'
8	83T15	20'	83T15	20'

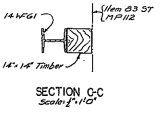
Note:
For design purposes, the pile load area and exceed 35' and the foundation pressure does not exceed 200 lbs per square foot. The maximum length of pile as indicated in the table is to be measured from the bottom of the footing.



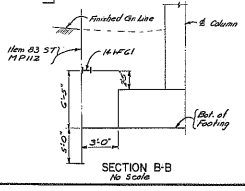
SHEETING PLAN
TYP. PIERS 5WB, 6EB, 7WB
No Scale



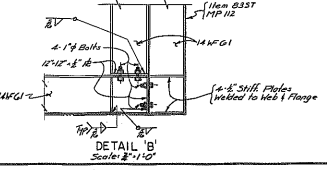
SECTION A-A
TYP. PIERS 5WB, 6EB, 7WB
Scale: 1/4"=1'-0"



SECTION C-C
Scale: 1/4"=1'-0"



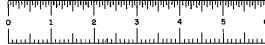
SECTION B-B
No Scale



DETAIL 'B'
Scale: 3/4"=1'-0"

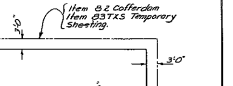
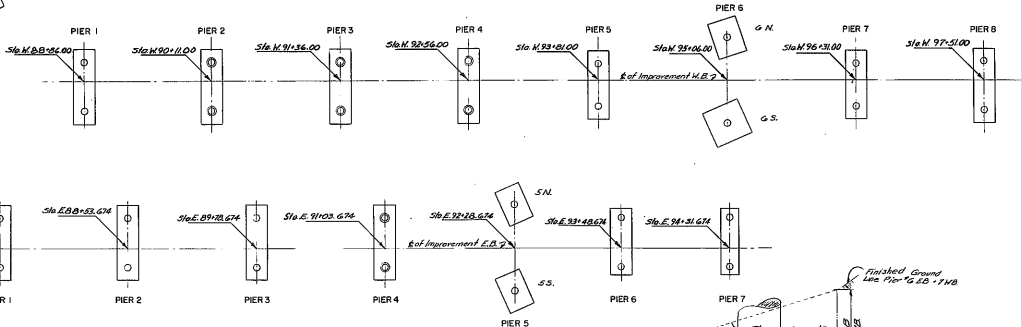
PROJECT ENGINEER: *[Signature]*
IN CHARGE OF: *[Signature]*
DESIGNED BY: *[Signature]*
CHECKED BY: *[Signature]*
DETAIL CHECKED BY: *[Signature]*

SR. NO. 2
SOUTHERN TIER EXPRESSWAY
OVER TIE-LOCKMANNA R.R.
PIER LAYOUT
8
SHEETING DETAILS
DRAWING NO. 17 OF 44



FILE NO.	STATE	FEDERAL RD DISTRICT NO.	SHEET NO.	TOTAL SHEETS
NEW YORK	APD-231(21)	117R	200	

SOUTHERN RIVER EXPRESSWAY, SECTION OR LOCAL-HAVERLY, PART 1 CHEMUNG COUNTY



Note: Grade to finished ground before placing 03TXS or 83ST.

SCHEMATIC PIER LAYOUT
Not to Scale

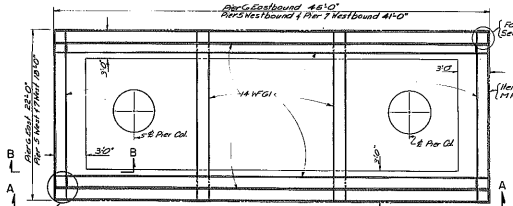
Location	WESTBOUND		EASTBOUND	
	SHEETING LENGTH	EST. PILE LENGTH	SHEETING LENGTH	EST. PILE LENGTH
Pier No. 1	03TXS 30'	10'	03TXS 30'	10'
2	03TXS 30'	10'	03TXS 30'	10'
3	03TXS 30'	10'	03TXS 30'	10'
4	03TXS 30'	10'	03TXS 30'	10'
5	03TXS 30'	10'	03TXS 30'	10'
6	03TXS 30'	10'	03TXS 30'	10'
7	03TXS 30'	10'	03TXS 30'	10'
8	03TXS 30'	10'	03TXS 30'	10'

Note: For design purposes, the pile head does not exceed 35 tons and the foundation pressure does not exceed 35 tons per square foot. The maximum length of pile as indicated in the table is to be measured down the duration of the footing.

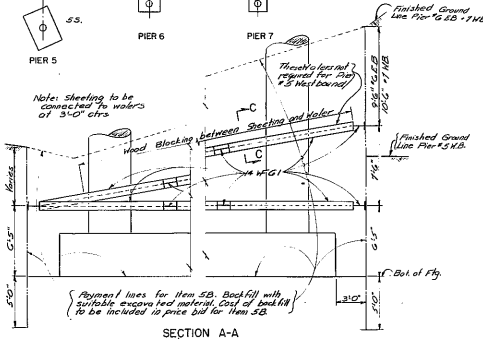
APPROVED
10/13/57
[Signature]
Supt. Civil Engr. Sec.

FIELD CHANGE SHEET

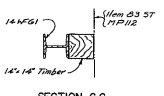
BL. NO. 2
SOUTHERN RIVER EXPRESSWAY
OVER DEL-LACOMARA P.R.
PIER LAYOUT
B
SHEETING DETAILS
DRAWING NO. 17044



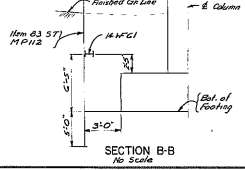
SHEETING PLAN
TYP PIER S, W, E, G, B, T, W
No Scale



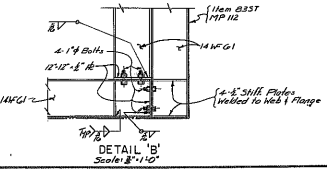
SECTION A-A
TYP. PIER S, W, E, G, B, T, W
Scale 1/2"=1'-0"



SECTION C-C
Scale 1/2"=1'-0"

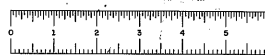


SECTION B-B
No Scale



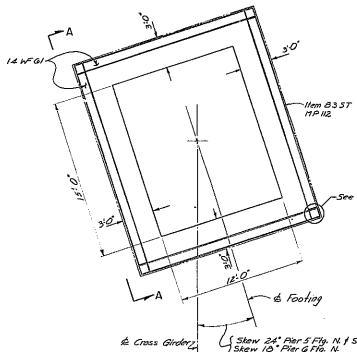
DETAIL 'a'
Scale 1/2"=1'-0"

PROJECT ENGINEER: [Signature]
IN CHARGE OF: [Signature]
DESIGNED BY: [Signature]
CHECKED BY: [Signature]
DETAIL CHECKED BY: [Signature]



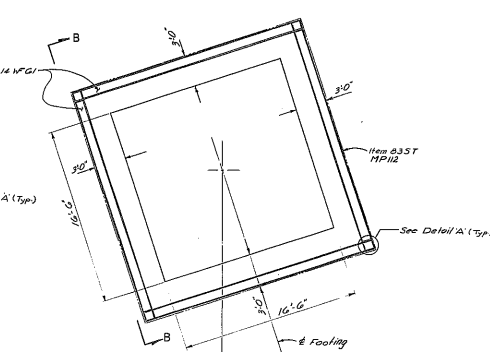
JOB NO.	STATE	FORM NO.	SHEET NO.	TOTAL SHEETS
118	APD-231(21)	118	200	

SOUTHERN TIER EXPRESSWAY, SECTION OR LONGBAY-MAVERLY, PART 1
COLUMBIA COUNTY

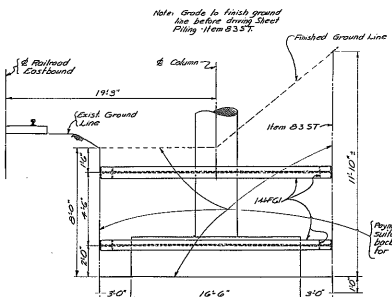
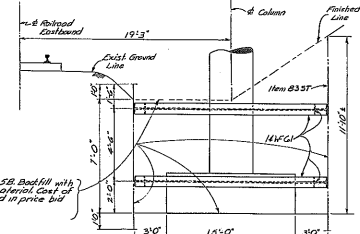
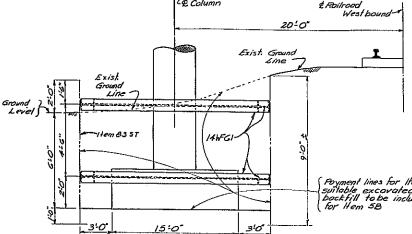
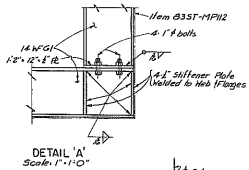


SHEETING PLAN
PIER 5WB NORTH B SOUTH COL.
PIER 6 EB NORTH COL.
Scale: 1/4" = 1'-0"

Note: Sheeting to be connected to wholes @ 3'-0" c/c's.



SHEETING PLAN-PIER 6 EB SOUTH COL.
Scale: 1/4" = 1'-0"

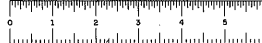


PROJECT ENGINEER: *[Signature]*
 BY CHANGE OF: *[Signature]*
 DESIGNED BY: *[Signature]*
 DESIGN CHECKED BY: *[Signature]*
 DETAIL CHECKED BY: *[Signature]*

(Payment lines for Item 5B Backfill with suitable excavated material. Cost of backfill to be included in price bid for Item 5B.)

(Payment lines for Item 5B Backfill with suitable excavated material. Cost of backfill to be included in price bid for Item 5B.)

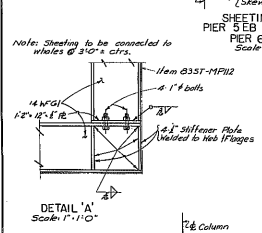
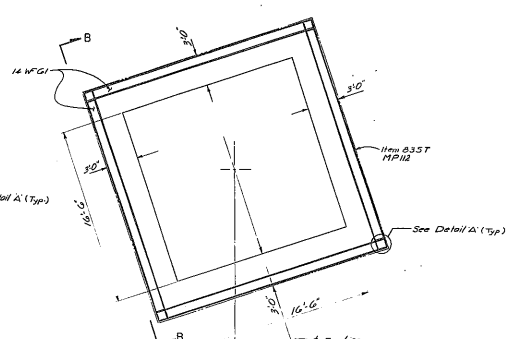
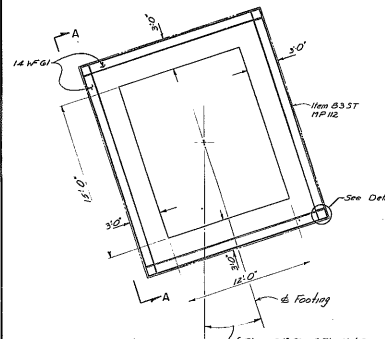
28, No. 2
SOUTHERN TIER EXPRESSWAY
OVER BLUE-CALUMNIA R.R.
SHEETING DETAILS



NO. NO.	STATE	FORMING AND PROJECT NO.	SHEET NO.	TOTAL SHEETS
	NEW YORK	APD-23(21)	118F1	200

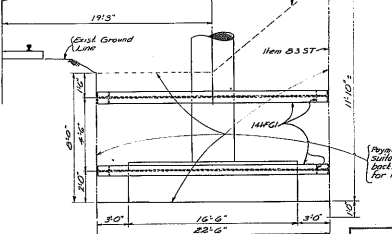
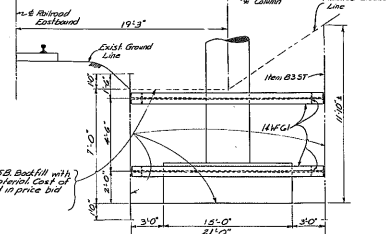
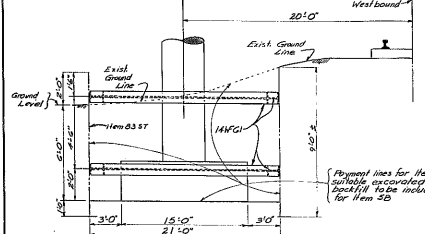
SOUTHERN TIER EXPRESSWAY, SECTION 6R
LOCAL-MAVERLY, PART 1
CHENANGO COUNTY

FIELD CHANGE SHEET



SHEETING PLAN-PIER 5 EB NORTH & SOUTH COL. Scale: 1/4"-1'-0"

SHEETING PLAN-PIER 6 WB NORTH & SOUTH COL. Scale: 1/4"-1'-0"



APPROVED
JUL 1 1977
[Signature]
Dist. Civil Engr. (Dist.)

Payment lines for Item 5B Backfill with suitable excavated material. Cost of backfill to be included in price bid for Item 5B.

PROJECT ENGINEER: *[Signature]*
 BY CHECKED BY: *[Signature]*
 DESIGNED BY: *[Signature]*
 DETAILER BY: *[Signature]*
 DETAIL CHECKED BY: *[Signature]*

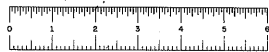
SECTION A-A
PIER 5 NORTH & PIER 6 NORTH
No Scale

SECTION A-A (TYP)
PIER 5 SOUTH
No Scale

SECTION B-B
PIER 6 SOUTH
No Scale

SHEETING DETAILS

DRAWING NO. 18 OF 46

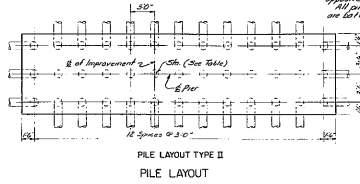
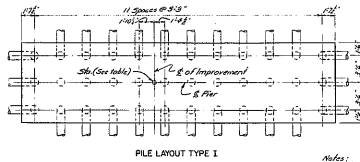
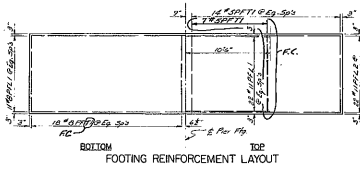
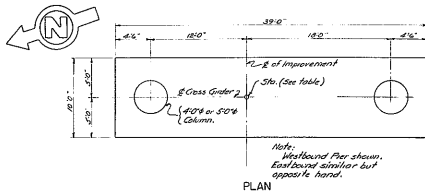


NO. OF SHEETS	STATE	FEDERAL AID PROJECT NO.	SHEET NO.	TOTAL SHEETS
119	NEW YORK	119	200	200

SOUTHERN TIER EXPRESSWAY, SECTION 6B
LONGHUB-WATERLY, PIER 1
CHENANGO COUNTY

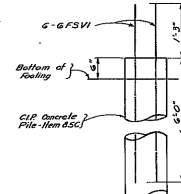
FIELD CHANGE SHEET

Note: Field change indicated F.C.



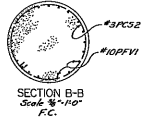
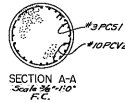
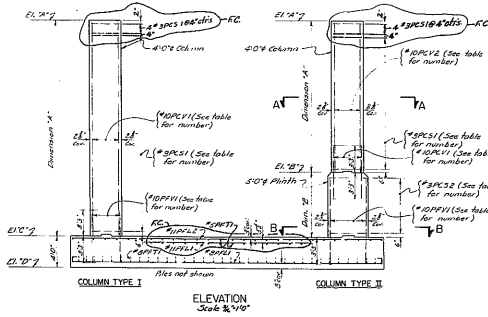
Note: Maximum Radius shown. Eastbound similar but opposite hand. All data indicated battered as indicated Govt. 1.

Note: For extended length of piles see Disp. #12.



Note: Piles to be filled with Class A Concrete. Cast to be included in Item 2.1.2. Reinforcing to be paid for under Item 2.0.

APPROVED
11/15/87
[Signature]
11/15/87
11/15/87



PIER TABLE

STATION	PIER	PILE PLAN	COL. TYPE	EL. "A"	EL. "B"	EL. "C"	EL. "D"	DM. "A"	DM. "B"	OPPV1	OPCV1	OPCV2	OPCV3	OPCV4
W38+00.00	Pier #1 W.B.	I	I	824.26	787.76	770.26	392.2	392.2	392.2	22	22	-	22	22
W38+10.00	Pier #2 W.B.	I	II	815.77	775.27	757.77	402.7	402.7	402.7	22	22	22	22	22
W38+20.00	Pier #3 W.B.	I	II	826.28	789.78	772.28	402.7	402.7	402.7	22	22	22	22	22
W38+30.00	Pier #4 W.B.	II	II	826.28	789.78	772.28	402.7	402.7	402.7	22	22	22	22	22
W38+40.00	Pier #5 W.B.	I	I	826.28	789.78	772.28	402.7	402.7	402.7	22	22	22	22	22
E09+28.074	Pier #1 E.B.	I	I	824.26	787.76	770.26	392.2	392.2	392.2	22	22	-	22	22
E09+38.076	Pier #2 E.B.	I	I	824.26	787.76	770.26	392.2	392.2	392.2	22	22	-	22	22
E09+48.078	Pier #3 E.B.	I	I	824.26	787.76	770.26	392.2	392.2	392.2	22	22	-	22	22
E09+58.080	Pier #4 E.B.	II	II	824.26	787.76	770.26	392.2	392.2	392.2	22	22	22	22	22

Note: For details of top of column and anchor bolts see Disp. #23.

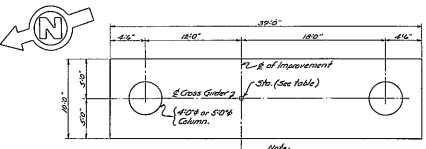
PROJECT ENGINEER: *[Signature]*
IN CHARGE OF: *[Signature]*
DESIGNED BY: *[Signature]*
DESIGN CHECKED BY: *[Signature]*
DETAILS BY: *[Signature]*
LOCAL CHECKED BY: *[Signature]*

DR. NO. 2
SOUTHERN TIER EXPRESSWAY
OVER ERLE-LACKAWANNA R.R.
WESTBOUND PIERS 1,2,3,4 & 8
EASTBOUND PIERS 1,2,3 & 4
DRAWING NO. 19 OF 44

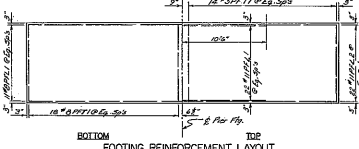


FED. PROJ. NO.	STATE	FEDERAL AID PROJECT NO.	SHEET NO.	TOTAL SHEETS
	NEW YORK	APD-21(21)	119	200

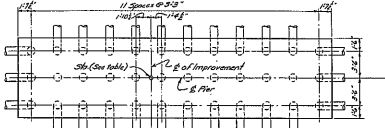
SOUTHERN TIER EXPRESSWAY, SECTION 6A
 (SOUTH-HAVEN), PART 1
 CENSING COUNTY



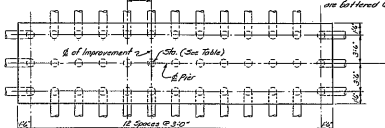
PLAN



FOOTING REINFORCEMENT LAYOUT

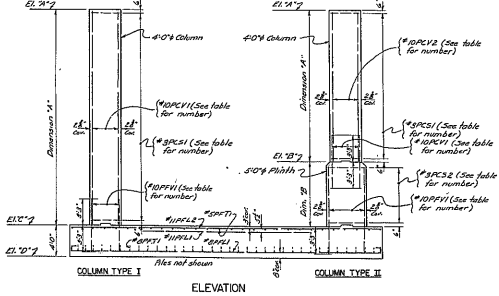


PILE LAYOUT TYPE I



PILE LAYOUT TYPE II

Note:
 Westbound Piers shown
 Eastbound omitted but
 opposite hand.
 All piles indicated battered
 on different cant.



ELEVATION

PIER TABLE

STATION	PIER	PILE PLAN	COL. TYPE	EL. "A"	EL. "B"	EL. "C"	EL. "D"	DM. "A"	DM. "B"	KOPVW	KOPV1	KOPV2	SPCS1	SPCS2
W 00+00.00	Pier #1 E.B.	I	I	824.70	-	792.50	770.70	40'0"	40'0"	22'	22'	-	22'	-
W 00+10.00	Pier #2 E.B.	I	II	826.47	795.47	771.47	752.47	40'0"	40'0"	22'	22'	22'	40'	4'
W 01+26.00	Pier #3 W.B.	I	II	826.40	794.40	771.40	752.40	40'0"	40'0"	22'	22'	22'	40'	5'
W 02+20.00	Pier #4 E.B.	II	I	826.98	794.98	771.98	752.98	40'0"	40'0"	22'	22'	22'	40'	10'
W 03+00.00	Pier #5 E.B.	I	I	825.00	-	792.00	770.00	40'0"	40'0"	22'	22'	-	22'	-
E 01+20.074	Pier #1 E.B.	I	I	823.70	-	791.50	770.70	40'0"	40'0"	22'	22'	-	22'	-
E 02+20.074	Pier #2 E.B.	I	I	824.49	-	794.29	770.59	40'0"	40'0"	22'	22'	-	22'	-
E 03+20.074	Pier #3 E.B.	I	I	825.28	-	794.08	770.38	40'0"	40'0"	22'	22'	-	22'	-
E 04+20.074	Pier #4 E.B.	II	II	826.00	796.00	772.00	753.00	40'0"	40'0"	22'	22'	22'	40'	9'

Note:
 For details of top of column and
 anchor bolts see Orig. #83.

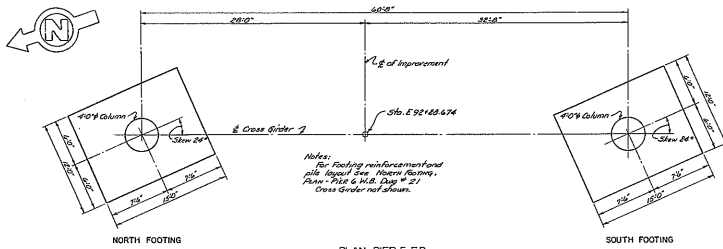
PROJECT ENGINEER: *J. J. [Signature]*
 IN CHARGE OF: *[Signature]*
 DESIGNED BY: *[Signature]*
 DESIGN CHECKED BY: *[Signature]*
 DETAILS BY: *[Signature]*
 DATA CHECKED BY: *[Signature]*

DR. NO. 2
 SOUTHERN TIER EXPRESSWAY
 OVER THE LAGUASHAWA R.R.
 WESTBOUND PIERS 1,2,3,4 & 8
 EASTBOUND PIERS 1,2,3 & 4
 DRAWING NO. 19 OF 24

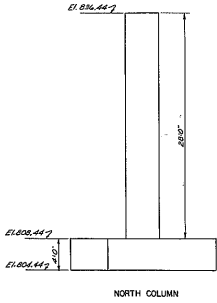


FED. RD. DIST. NO.	STATE	FEDERAL AID PROJECT NO.	SHEET NO.	TOTAL SHEETS
	NEW YORK	APD-221(21)	120	200

SOUTHERN TIER EXPRESSWAY, SECTION 6B
 LAKESHORE-HAZEL, PART 1
 CHEROKEE COUNTY

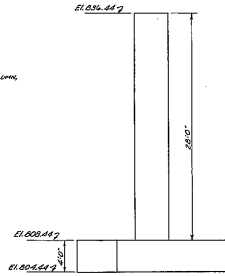


PLAN-PIER 5 EB.
 Scale 1/4"=1'-0"



NORTH COLUMN

Notes:
 For column reinforcement see South Column Elevation Pier 5 M.S. Draw # 21.



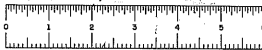
SOUTH COLUMN

ELEVATION
 Scale 1/4"=1'-0"

Note:
 For details of top of columns and anchor balls see Draw # 23.

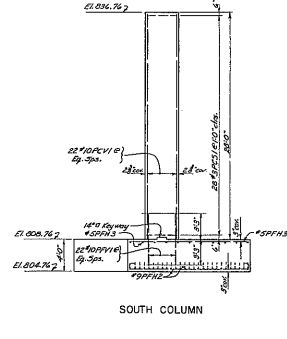
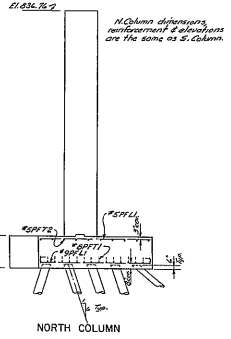
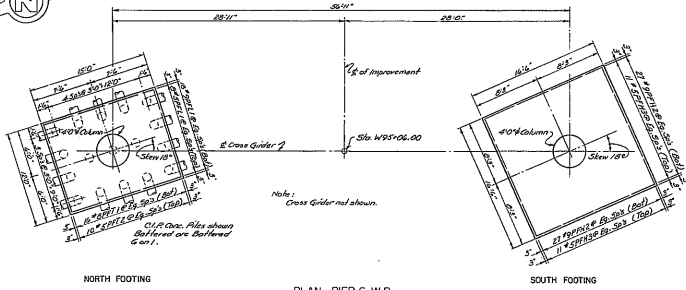
PROJECT ENGINEER: *[Signature]*
 IN CHARGE OF: *[Signature]*
 DESIGNED BY: *[Signature]*
 DESIGN CHECKED BY: *[Signature]*
 DETAIL BY: *[Signature]*
 DETAIL CHECKED BY: *[Signature]*

IN. NO. 2
 SOUTHERN TIER EXPRESSWAY
 OVER TALLE-LAKESHORE R.R.
 EASTBOUND
 PIER 5
 DRAWING NO. 20 OF 44



NO. OF SHEETS	STATE	FEDERAL AID PROJECT NO.	SHEET NO.	TOTAL SHEETS
	NEW YORK	APD-221(213)	121	200

SOUTHERN TIER EXPRESSWAY, SECTION 6R
LONGMAN-WARELY, PART 1
COLUMBIAN COUNTY



PROJECT ENGINEER: *[Signature]*
 IN CHARGE OF: *[Signature]*
 DESIGNED BY: *[Signature]*
 CHECKED BY: *[Signature]*

Note: For Details of Top of Column and Anchor Bolts see Drawing No. 23.

SE. NO. 2
 SOUTHERN TIER EXPRESSWAY
 OVER EXIE-LACKAWANNA R.R.
 WESTBOUND
 PIER 6

DRAWING NO. 21 OF 44



FA.S.T.E. G7-4

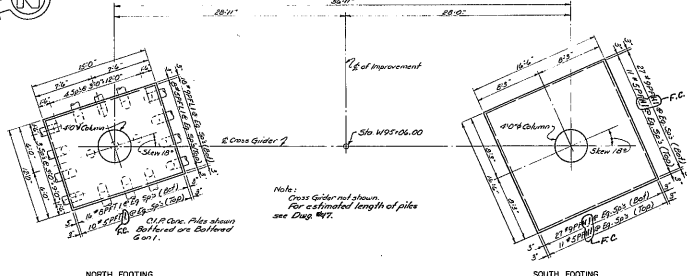
FA.S.T.E. G7-4

FED. DIST. DIST. NO.	STATE	FEDERAL AID PROJECT NO.	SHEET NO.	TOTAL SHEETS
	NEW YORK	5-14-2-1-1	12.17	200

SOUTHERN FIEL EXPRESSWAY, SECTION 08
LONG-ISLAND CITY, PART 1
CHENING COUNTY

FIELD CHANGE SHEET

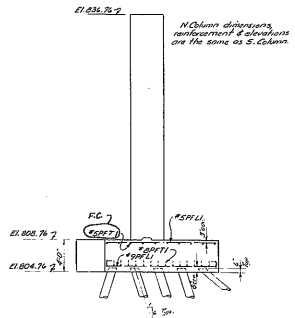
Note: Field change indicated - F.C.



NORTH FOOTING

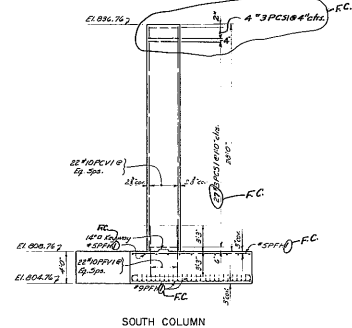
SOUTH FOOTING

PLAN - PIER 6 W.B.
Scale 1/4" = 1'-0"



NORTH COLUMN

ELEVATION NORTH COLUMN
Scale 1/4" = 1'-0"



SOUTH COLUMN

APPROVED
DEC 23 1957

[Signature]
CHIEF ENGINEER

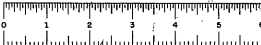
Note: For Details of Top of Column and Anchor Bolts see Drawing No. 2.

PROJECT ENGINEER: *[Signature]*
IN CHARGE OF: *[Signature]*
DESIGNED BY: *[Signature]*
CHECKED BY: *[Signature]*
DETAIL CHECKED BY: *[Signature]*

SH. 2
SOUTHERN FIEL EXPRESSWAY
OVER L.I.C. EXPRESSWAY R.R.
WESTBOUND
PIER 6
DRAWING NO. 21 OF 24

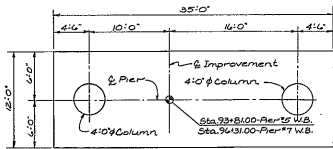
FA.S.T.E. G7-4

FA.S.T.E. G7-4

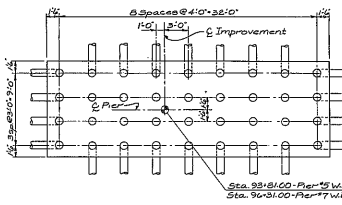


FILE NO.	STATE	FORM NO.	SHEET NO.	TOTAL SHEETS
NEW YORK	APD-221(2)1	122	200	

SOUTHERN TIER EXPRESSWAY, SECTION OR
LONGHAY-RAVENSLEY, PAGE 1
CATTARAUGUS COUNTY

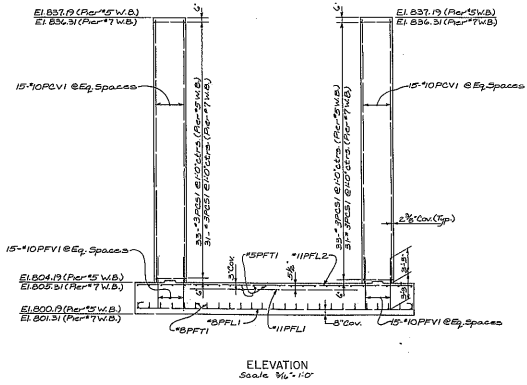


PLAN
Scale 3/8"=1'-0"

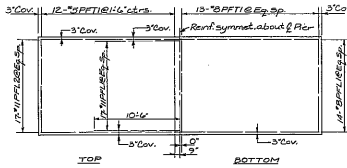


PILE PLAN
Scale 3/8"=1'-0"

Note:
Batter Piles indicated 6 on.



ELEVATION
Scale 3/8"=1'-0"



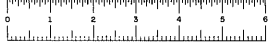
FOOTING REINFORCEMENT PLAN
Scale 3/8"=1'-0"

PROJECT ENGINEER: *[Signature]*
 IN CHARGE OF: *[Signature]*
 DESIGN CHECKED BY: *[Signature]*
 DETAIL BY: *[Signature]*
 SOCIAL CHECKED BY: *[Signature]*

Note: Piles not shown in elevation.
See dwg. no. 23 for details of top of pier column and anchor bolts.

SOUTHERN TIER EXPRESSWAY
 OVER THE LACKAWANNA R.R.
 WESTBOUND
 PIERS 5&7

DRAWING NO. 22 OF 44

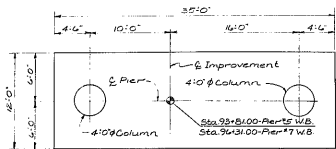


REG. NO.	STATE	PROJECT NO.	SHEET NO.	TOTAL SHEETS
	NEW YORK		122	200

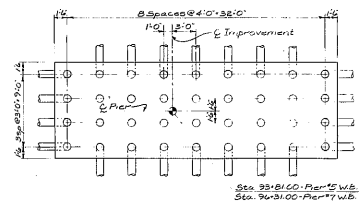
SOUTHERN PIER IMPROVEMENT, SECTION OF
LONGHAI-WATERLY, PART I
SEBASTIAN COUNTY

FIELD CHANGE SHEET

Note: Field change indicated - F.C.

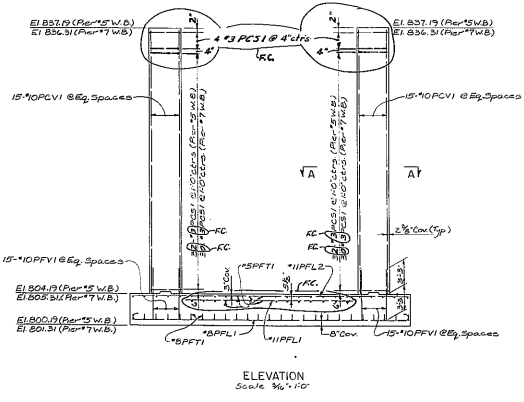


PLAN
Scale 3/4"=1'-0"

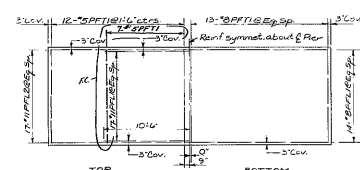


PILE PLAN
Scale 3/4"=1'-0"

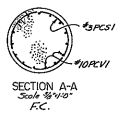
Note: Batter Piles indicated 6 cent. For estimated length of piles see drawing 17.



ELEVATION
Scale 3/4"=1'-0"



FOOTING REINFORCEMENT PLAN
Scale 3/4"=1'-0"



SECTION A-A
Scale 3/4"=1'-0"

APPROVED
1988
K. J. [Signature]
SEBASTIAN COUNTY ENGINEER

PROJECT ENGINEER: [Signature]
IN CHARGE OF: [Signature]
DESIGNED BY: [Signature]
DESIGN CHECKED BY: [Signature]
DETAILED BY: [Signature]
DETAIL CHECKED BY: [Signature]

Note: Piles not shown in elevation. See drawing 23 for details of top of pier column and anchor bolts.

DR. NO. 2
SOUTHERN PIER IMPROVEMENT
OVER BRIDGE-SECTION 1000 S.W.

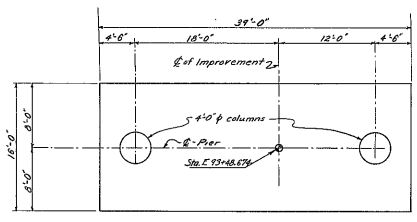
WESTBOUND
PIERS 5B/7

DRAWING NO. 22 OF 24

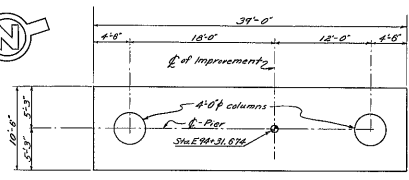


FIG. NO.	STATE	FEDERAL AID PROJECT NO.	SHEET NO.	TOTAL SHEETS
	NEW YORK	APD-231(2)13	123	200

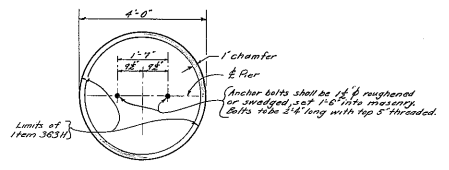
SOUTHERN TIER EXPRESSWAY, SECTION OR LOCAL-MAINTENANCE, PART 1
CHENANGO COUNTY



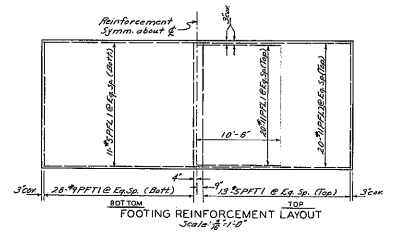
PLAN PIER 6 - E.B.
Scale: 1/4" = 1'-0"



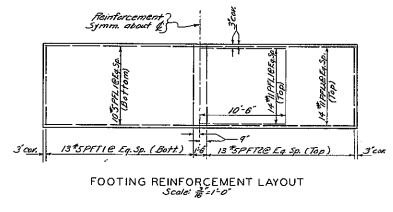
PLAN PIER 7 - E.B.
Scale: 1/4" = 1'-0"



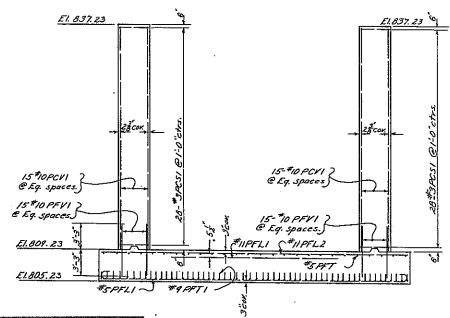
TYPICAL TOP OF COLUMNS
No Scale



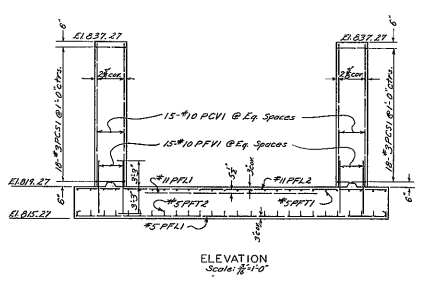
FOOTING REINFORCEMENT LAYOUT
Scale: 1/8" = 1'-0"



FOOTING REINFORCEMENT LAYOUT
Scale: 1/8" = 1'-0"



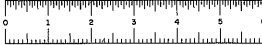
ELEVATION
Scale: 1/4" = 1'-0"



ELEVATION
Scale: 1/4" = 1'-0"

PROJECT ENGINEER: *[Signature]*
IN CHARGE OF: *[Signature]*
DESIGNED BY: *[Signature]*
DESIGN CHECKED BY: *[Signature]*
DETAIL CHECKED BY: *[Signature]*

SH. NO. 2
SOUTHERN TIER EXPRESSWAY
OVER ELEGANTHAWK R.R.
EASTBOUND
PIERS 6 & 7
DRAWING NO. 23 OF 44

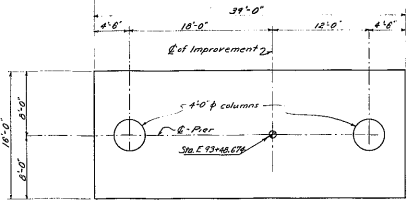


NO. NO.	STATE	FEDERAL AID PROJECT NO.	SHEET NO.	TOTAL SHEETS
	NEW YORK		123-A-00	

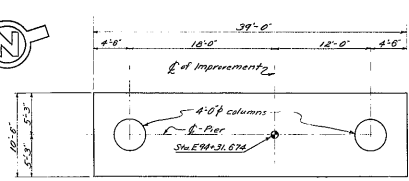
SOUTHERN FERRIS EXPRESSWAY, SECTION 6A
LONGHUB-MAVERICK, PART 1
CHENANGO COUNTY

FIELD CHANGE SHEET

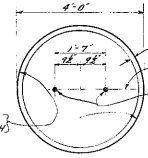
Note: Field change indicated - RC



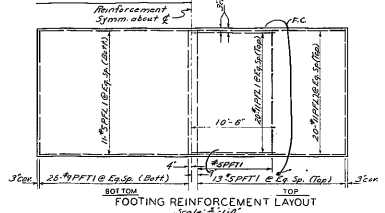
PLAN PIER 6 - E.B.
Scale: 1/4"=1'-0"



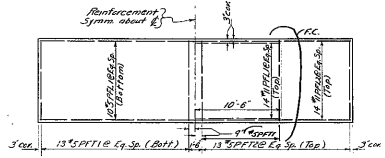
PLAN PIER 7 - E.B.
Scale: 1/4"=1'-0"



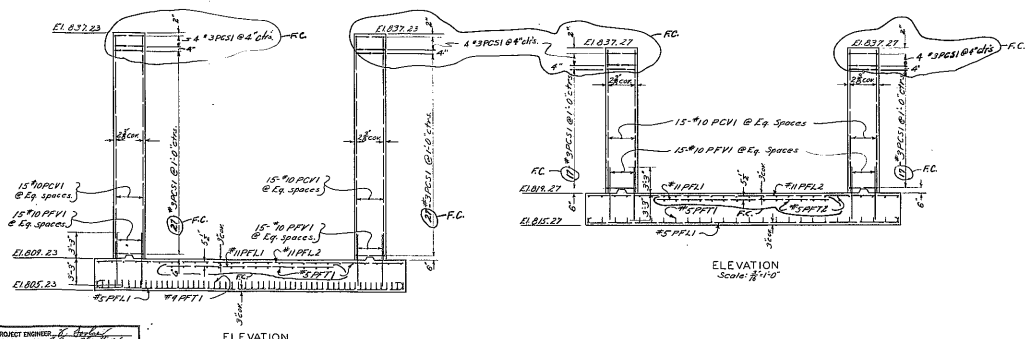
TYPICAL TOP OF COLUMNS
No Scale



FOOTING REINFORCEMENT LAYOUT
Scale: 1/4"=1'-0"



FOOTING REINFORCEMENT LAYOUT
Scale: 1/4"=1'-0"



ELEVATION
Scale: 1/4"=1'-0"

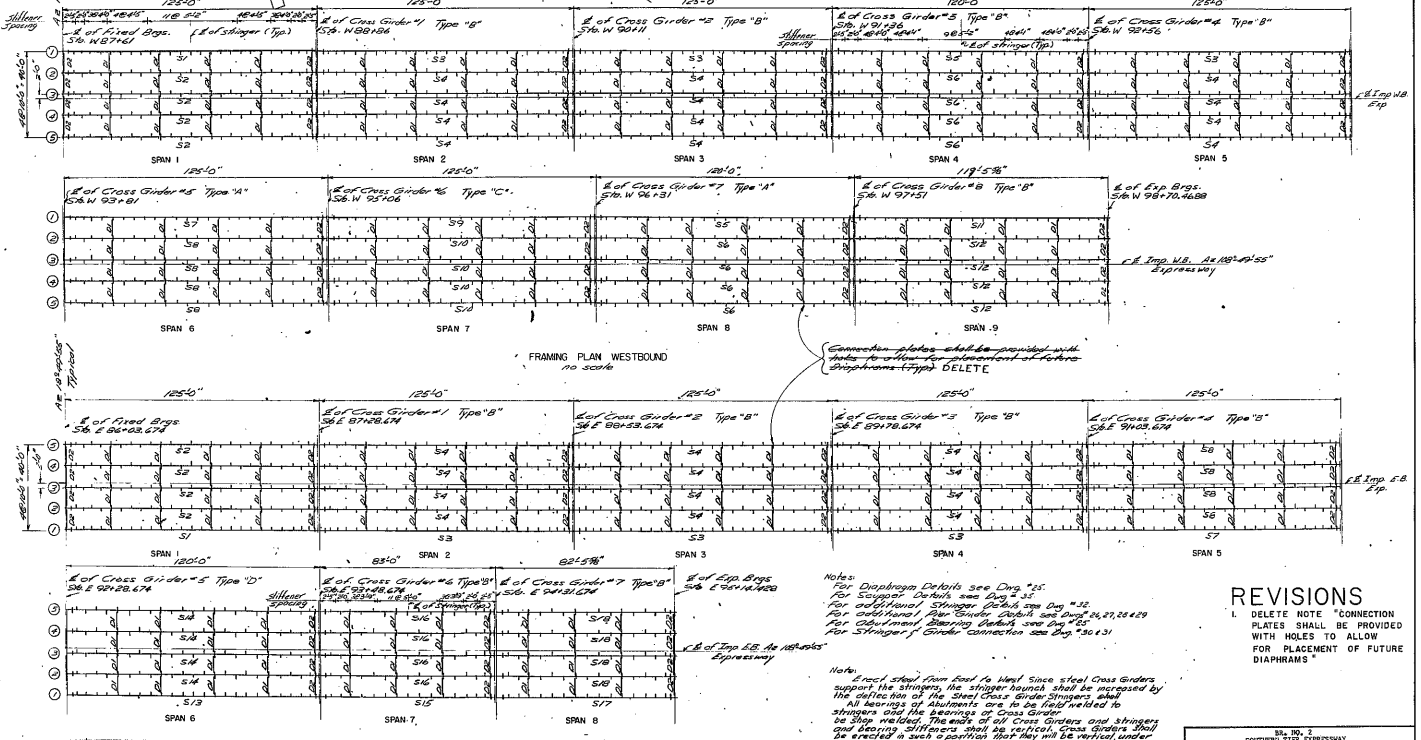
APPROVED
DATE: 11/1/87
[Signature]
Park Dist. Insp. - Road

PROJECT FINISHED BY: *[Signature]*
IN CHARGE OF: *[Signature]*
DESIGNED BY: *[Signature]*
CHECKED BY: *[Signature]*
DETAILS BY: *[Signature]*
FINAL CHECKED BY: *[Signature]*

BR. NO. 2
SOUTHERN FERRIS EXPRESSWAY
OVER BELL-CORNINGAN I.P.T.
EASTBOUND
PIERS 6 & 7
DRAWING NO. 23 OF 24

FED. RD. DIST. NO.	STATE	FEDERAL AID PROJECT NO.	SHEET NO.	TOTAL SHEETS
NEW YORK	NY	AID-217(12)2	124	193

SOUTHERN TIES EXPRESSWAY, SECTION 68
LONGMEADOW, TOWN OF
COLUMBIUS COUNTY



FRAMING PLAN WESTBOUND
no scale

FRAMING PLAN EASTBOUND
no scale

Connection plates shall be provided with holes for welding to adjacent end of girder.
Diaphragms (if any) DELETE

- Notes
- For Diaphragm Details see Div 15.
 - For Stinger Details see Div 15.
 - For odd Numbered Stinger Details see Div 15.
 - For odd Numbered Floor Girder Details see Div 15, 21, 22 & 29.
 - For Odd Numbered Bearing Details see Div 15.
 - For Stingers of Girder connection see Div 15 & 17.

Note: End steel from end to end since steel Cross Girders support the stringers, the stringer bays shall be increased by the deflection of the steel Cross Girder stringers. All bearings or abutments are to be field welded to stringers and the bearings of Cross Girder be shop welded. The ends of all Cross Girders and stringers and bearing stiffeners shall be vertical. Cross Girders shall be erected in such a position that they will be vertical under full dead load.

REVISIONS

1. DELETE NOTE "CONNECTION PLATES SHALL BE PROVIDED WITH HOLES TO ALLOW FOR PLACEMENT OF FUTURE DIAPHRAGMS"

PROJECT ENGINEER: *[Signature]*
IN CHARGE OF: *[Signature]*
DESIGNED BY: *[Signature]*
DETAILS BY: *[Signature]*
DETAIL CHECKED BY: *[Signature]*

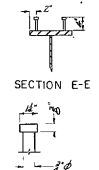
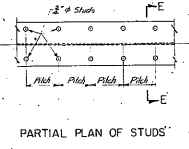
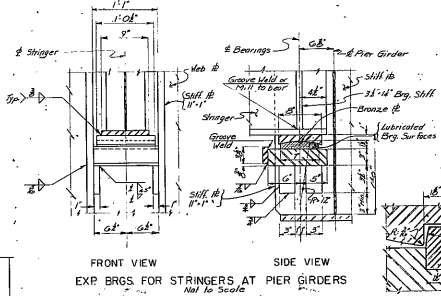
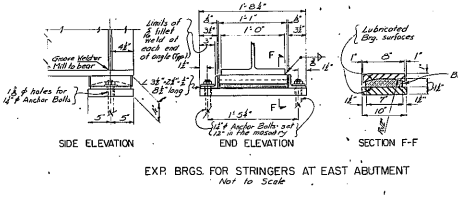
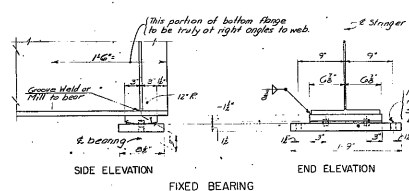
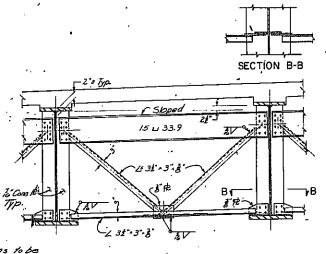
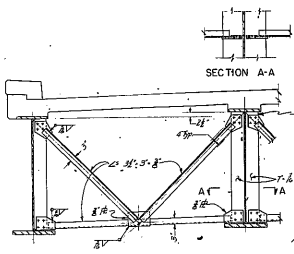
SHEET NO. 5
SOUTHERN TIES EXPRESSWAY
OVER BRIS-LICKAMANTIA R.R.

FRAMING PLAN
EASTBOUND & WESTBOUND

DRAWING NO. 24 OF 44

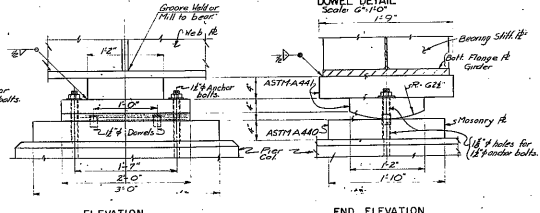
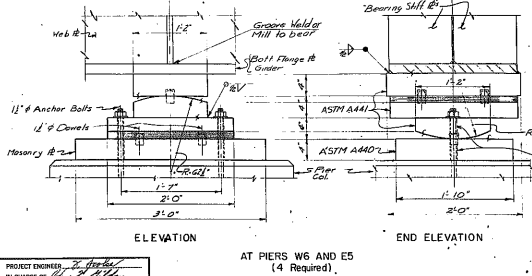
FED. AID PROJECT NO.	STATE	FEDERAL AID PROJECT NO.	SHEET NO.	TOTAL SHEETS
NEW YORK	AD 93 1011	125	19	199

SOUTHERN TIER EXPRESSWAY, SECTION ON LOCAL AVENUE, PART 3
CROSSLING COUNTY



DETAIL OF STUD
REVISIONS
I. ADDITION OF AMENDMENT NO. 3

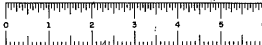
NOTES:
All anchor bolts shall be galvanized in accordance with the requirements of Material Specification M18.
Structural Steel members which are embedded or in contact with cast or pneumatically projected concrete shall not be painted.
Inhibit finished sliding surfaces in contact (pins, pin or one half pin rollers in sockets) shall operate in the shop one coat of a hot mixture of white lead and tallow as provided for in the specifications under Part II, section 5a, Painting. This shop coat of white lead and tallow shall be removed immediately prior to the assembly of the member in the field. All other machine finished surfaces shall be given one shop coat of paint.
Self lubricating Bronze Bearing Plate, Alloy "B", shall conform to Material Specification M18. Pay for under item 22.
AMENDMENT NO. 3 - ANCHOR BOLTS FROM ALL PIER GIRDER BEARINGS SHALL HAVE (2) NUTS. LOWER NUT SHALL BE HAND TIGHTENED AND BACKED OFF ONE QUARTER TURN. UPPER NUT SHOULD THEN BE TIGHTENED LOWER NUT. THREADS ABOVE UPPER NUT SHALL BE BURNED AFTER ASSEMBLY. THE HOLES IN THE ROCKER PLATE SHALL BE TAPERED FROM 1/2" AT THE CURVED SURFACE TO 2 1/4" AT THE FLAT SURFACE.



ROCKER BEARING DETAILS FOR ALL PIER GIRDERS
Scale: 1/2" = 1'-0"

PROJECT ENGINEER: J. J. ...
IN CHARGE OF WORK: ...
DESIGNED BY: ...
DESIGN CHECKED BY: ...
DETAILS BY: ...
REVISION CHECKED BY: ...

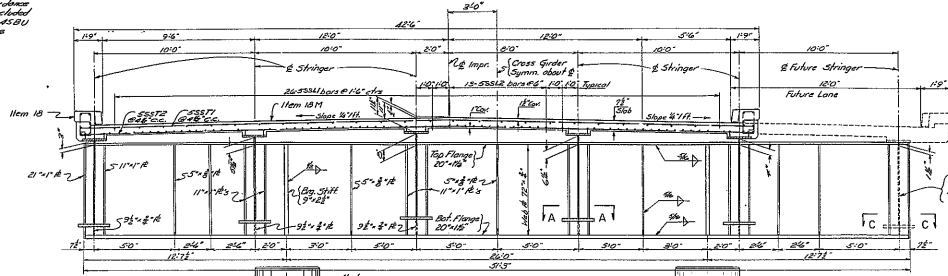
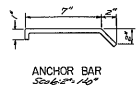
DR. NO. 2
SOUTHERN TIER EXPRESSWAY
OVER BRIDGE-CROSSLING T.P. 3
CROSS FRAMES & BEARING
DETAILS
DRAWING NO. 25 OF 24



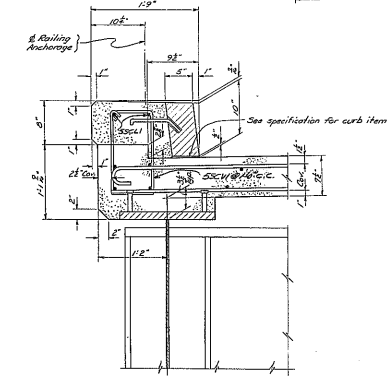
JOB NO.	STATE	FORMA AD PROJ. NO.	SHEET NO.	TOTAL SHEETS
	NEW YORK	APD-221(21)	126	200

SOUTHERN TIER EXPRESSWAY, SECTION 68
LONGH-WATERLY, PART 1
CENESSEX COUNTY

Note:
 2" dia. max. spacing requirements
 of 1/2" dia. reinforcement in accordance
 with NYO, Type II. Cast included
 in price bid for 2" dia. 20#
 square curb bridge type.



Note:
 For additional railing details
 see Day # 39



Note:
 Drawings not shown.
 For details see Day # 45

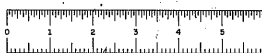
Note:
 All connection plates and
 intermediate stiffeners shall
 be welded to web and fitted
 joint tight to top and bottom
 flanges.
 Bearing stiffeners shall be
 welded to web and fitted joint
 tight to top flange. They shall
 be either bolted to deck or grout
 welded to bottom flange.

Note:
 For Sections AA, CC and
 Cross Girder Detail Type "B"
 zero center.

PROJECT ENGINEER: *[Signature]*
 IN CHARGE OF: *[Signature]*
 DESIGNER: *[Signature]*
 DESIGN CHECKED BY: *[Signature]*
 DETAILED BY: *[Signature]*
 SPECIAL CHECKED BY: *[Signature]*

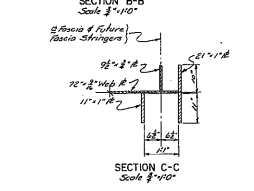
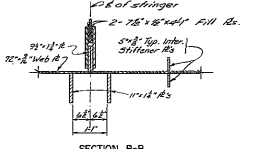
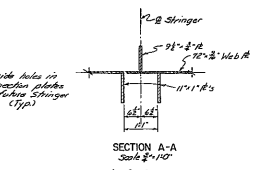
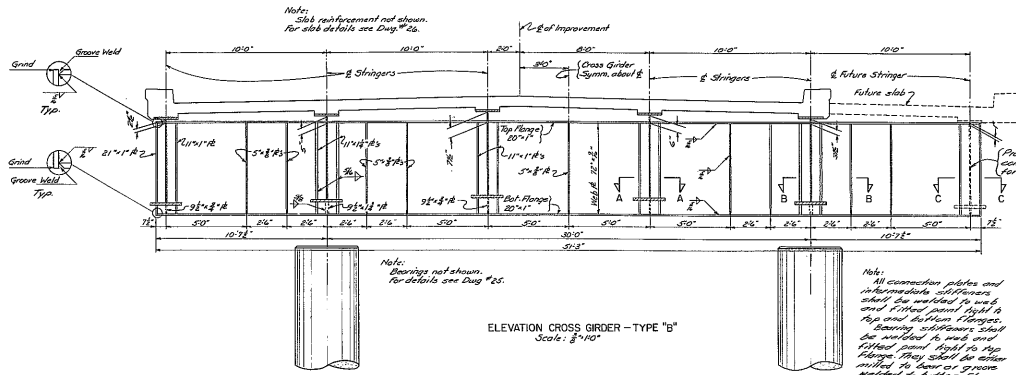
SECTION 6
 SOUTHERN TIER EXPRESSWAY
 OVER ERIE-LACKAWANNA R.R.

TRANSVERSE SECTION B
 CROSS GIRDER TYPE "A"
 DRAWING NO. 26 OF 44



FED. RD. DIST. NO.	STATE	FEDERAL PROJ. NO.	SHEET NO.	TOTAL SHEETS
	NEW YORK	APD-221(21)	127	200

SOUTHERN TIER EXPRESSWAY, SECTION OR LAMAR-WATERLY, PART 1
COLUMBIAN COUNTY



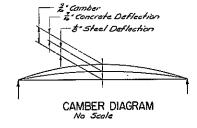
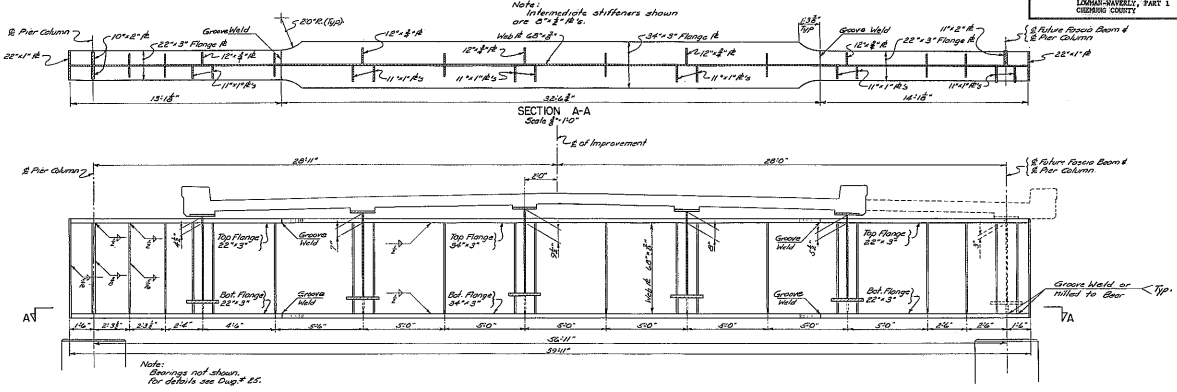
Note: Zero Camber

PROJECT ENGINEER: *[Signature]*
 IN CHARGE OF: *[Signature]*
 DESIGNED BY: *[Signature]*
 DESIGN CHECKED BY: *[Signature]*
 DETAILED BY: *[Signature]*
 DETAIL CHECKED BY: *[Signature]*

BL. NO. 2
 SOUTHERN TIER EXPRESSWAY
 OVER BEE-LICKHAMON R.R.
CROSS GIRDER TYPE "B"
 DRAWING NO. 27 OF 24



F.A.S.T.F. 67-4			
REL. NO.	STATE	FEDERAL AID PROJECT NO.	SHEET NO. TOTAL SHEETS
	NEW YORK	APD-231(C1)	128 200
SOUTHERN TIER EXPRESSWAY, SECTION 6R LONGHAWLEY, PART 1 CHENANGO COUNTY			



PROJECT ENGINEER: *[Signature]*
 IN CHARGE OF: *[Signature]*
 DESIGN CHECKED BY: *[Signature]*
 DETAILS BY: *[Signature]*
 DETAILS CHECKED BY: *[Signature]*

DR. NO. 2
 SOUTHERN TIER EXPRESSWAY
 OVER ESTE-LACKAWANNA R.R.
 CROSS GIRDER TYPE "C"
 DRAWING NO. 25 OF 44

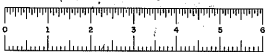
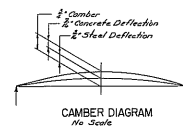
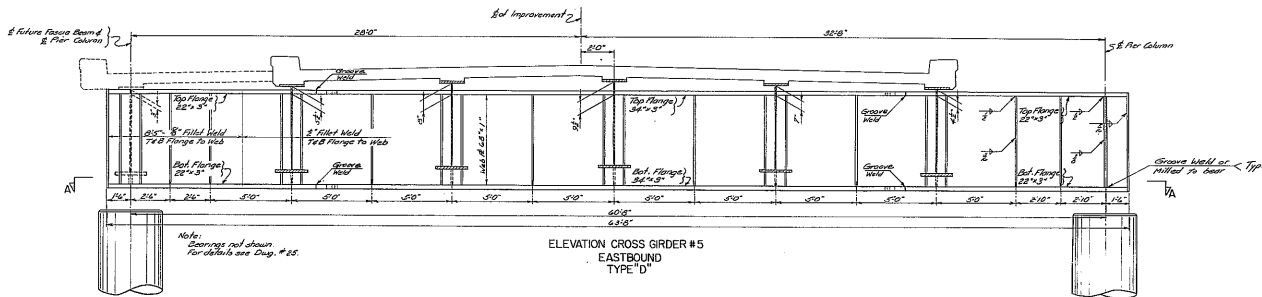
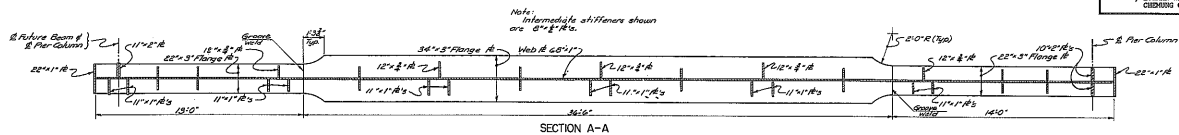


FIG. NO.	STATE	PROGRAM NO.	SHEET NO.	TOTAL SHEETS
	NEW YORK	APD-231(2)1	129	200

SOUTHERN TIER EXPRESSWAY, SECTION GR
LORAIN-HARTS, PART 1
CASSIA COUNTY

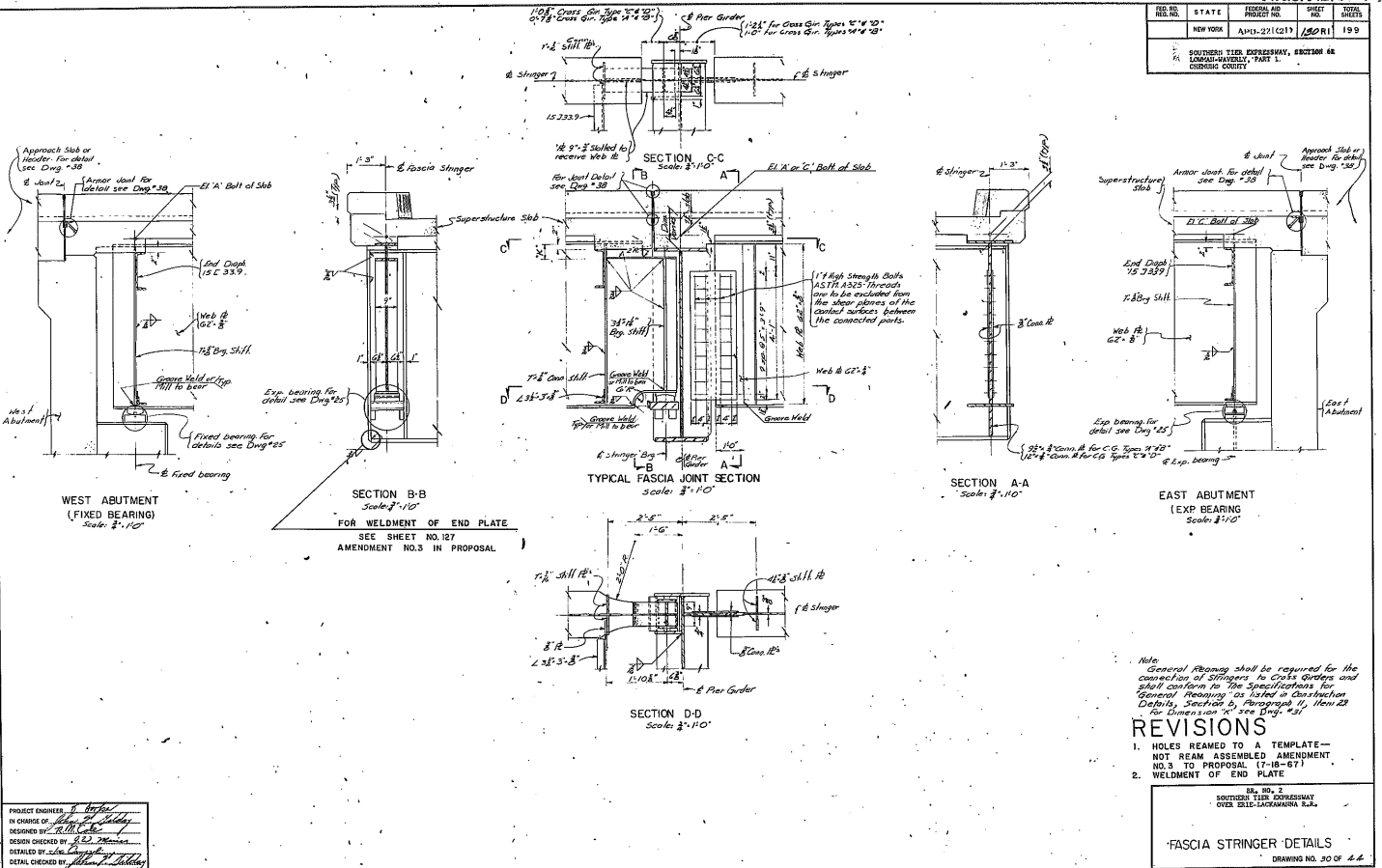


PROJECT ENGINEER	<i>J. Duffell</i>
IN CHARGE OF	<i>E. J. Kelly</i>
DESIGNED BY	<i>E. J. Kelly</i>
DRAWN BY	<i>A. M. Kelly</i>
CHECKED BY	<i>E. J. Kelly</i>
DATE	<i>11/11/70</i>

DR. NO. 2
SOUTHERN TIER EXPRESSWAY
OVER EAST-CASSIAWAY, N.E.
CROSS GIRDER TYPE "D"
DRAWING NO. 230 of 11

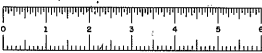
FED. PROJ. NO.	STATE	FEDERAL AID PROJECT NO.	SHEET NO.	TOTAL SHEETS
	NEW YORK	A141-2(1)(21)	10 R1	199

SOUTHERN TIER EXPRESSWAY, SECTION 6A
LONG-ISLAND BRIDGE, PART 1,
CORONA COUNTY



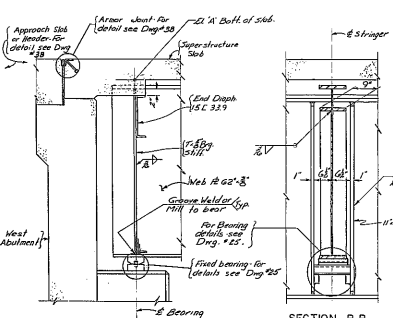
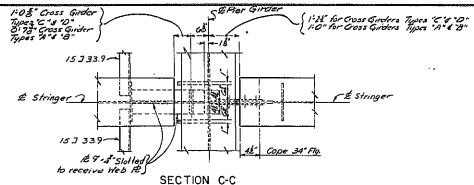
PROJECT ENGINEER: *[Signature]*
 IN CHARGE OF: *[Signature]*
 DESIGNED BY: *[Signature]*
 DESIGN CHECKED BY: *[Signature]*
 DETAILED BY: *[Signature]*
 DETAIL CHECKED BY: *[Signature]*

84, 85, 2
 SOUTHERN TIER EXPRESSWAY
 OVER ERIE-LACKAWANNA R.R.
 'FASCIA STRINGER DETAILS'
 DRAWING NO. 20 OF 44

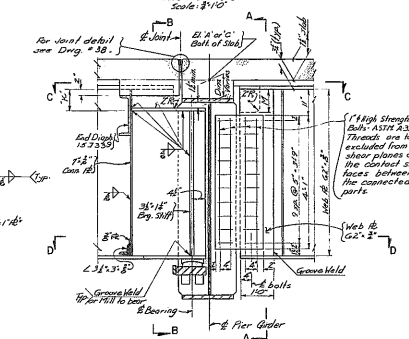


DES. NO.	STATE	FORMA. NO.	SHEET NO.	TOTAL SHEETS
NEW YORK	APD-221(17)	1/9	200	

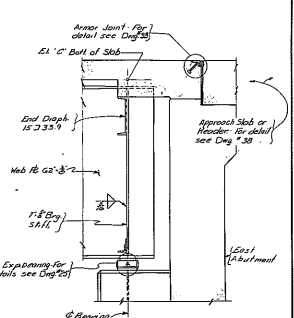
SOUTHERN TIER EXPRESSWAY, SECTION OR
 SOUTH-AVENUE, PART 1
 CHEROKEE COUNTY



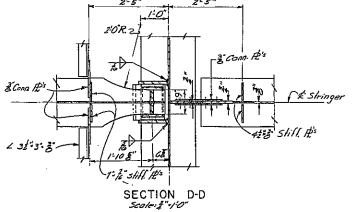
WEST ABUTMENT
(FIX. BEARING)
Scale: 3/4"=1'-0"



SECTION A-A
Scale: 3/4"=1'-0"



EAST ABUTMENT
(EXP. BEARING)
Scale: 3/4"=1'-0"



SECTION D-D
Scale: 3/4"=1'-0"

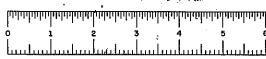
STRINGER ON LINE	CROSS GIRDER TYPES A,B,E		CROSS GIRDER TYPES C,D	
	K	M	K	M
1	5 1/2"	6 1/2"		
2	7 1/2"	7 1/2"	6 1/2"	
3	10 1/2"	11 1/2"	7 1/2"	
4	13 1/2"	14 1/2"	10 1/2"	7 1/2"
5	16 1/2"	17 1/2"	13 1/2"	10 1/2"

Note: General Reaming shall be required for the connection of Stringer to Cross Girders and shall conform to the Specifications for 'General Reaming' as listed in Construction Details, Section 5, Paragraph 4, Item 2c.

PROJECT ENGINEER: *[Signature]*
 IN CHARGE OF: *[Signature]*
 DESIGNED BY: *[Signature]*
 DESIGN CHECKED BY: *[Signature]*
 DETAIL CHECKED BY: *[Signature]*

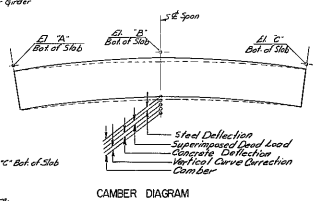
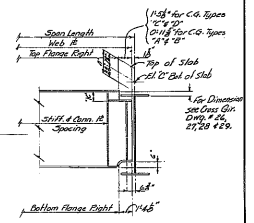
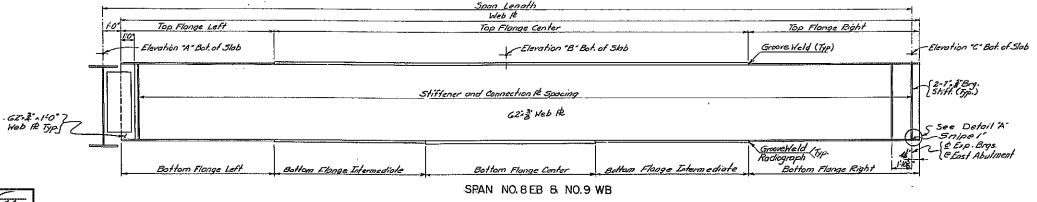
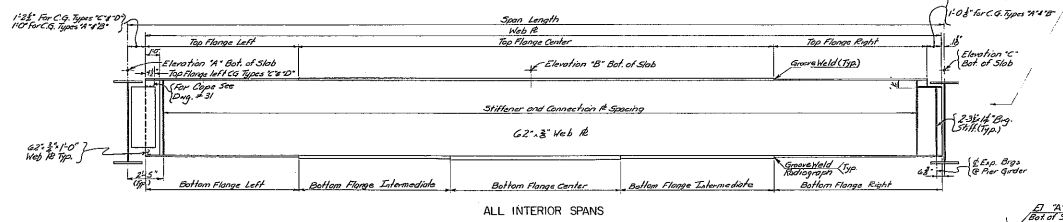
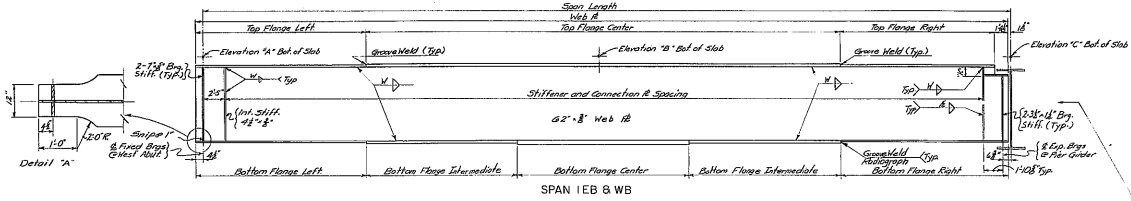
NO. 10
 SOUTHERN TIER EXPRESSWAY
 OVER BRLE-LACKAWANNA R.R.

INTERIOR & MALL STRINGER DETAILS
 DRAWING NO. 21 OF 44



FED. RD. DIST. NO.	STATE	FEDERAL AID PROJECT NO.	SHEET NO.	TOTAL SHEETS
	NEW YORK	APD-321(213)	132	200

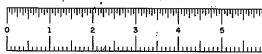
SOUTHERN TIER EXPRESSWAY, SECTION OR LOWAUL-NARVELLY, PART 1
CASSIUS COUNTY



Note:
 1/2" equals 3/8" for plates equal to or less than 1/2" thickness.
 1/2" equals 3/4" for plates greater than 1/2" in thickness.
 For Dimension "m" see Drawing No. 31 for Stringer Tables see Draw No. 35a-54

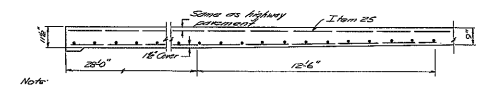
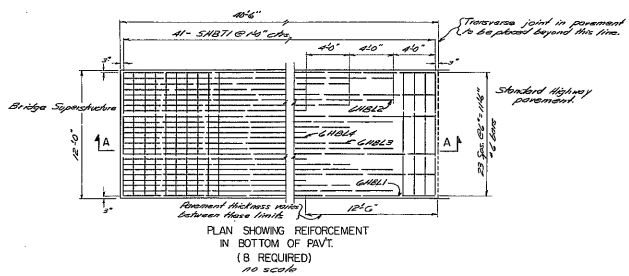
PROJECT ENGINEER: *[Signature]*
 IN CHARGE OF: *[Signature]*
 DESIGNED BY: *[Signature]*
 CHECKED BY: *[Signature]*
 DETAILED BY: *[Signature]*
 DETAIL CHECKED BY: *[Signature]*

TYPICAL STRINGER ELEVATION
 DRAWING NO. 12 OF 64

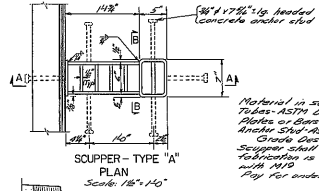


FILE NO.	STATE	PROJECT NO.	SHEET NO.	TOTAL SHEETS
	NEW YORK	APD-221(2)	135	200

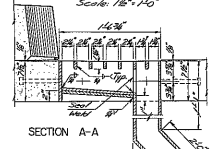
SOUTHERN TIER EXPRESSWAY, SECTION OR LONG-ISLAND, PART I
CASSIUS COUNTY



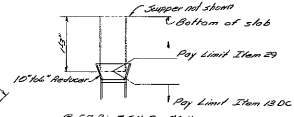
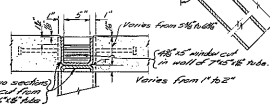
Note: Item 25 Reinforcement for structure is included in the bridge quantities. All other items shown in the Reinforced Concrete Approach Slab are included in the Highway Quantities.



Material in scupper - 1/2" dia. Tubes - ASTM Designation A307 Grade A Plates or Bars - ASTM Designation A36 Anchor Stud - ASTM Designation A307 Grade Designation 305 or A307 Scupper shall be constructed after consultation is complete in accordance with M 119 Pay Ref under Item 25.



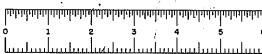
Place top of scupper on same slope as top of pavement.



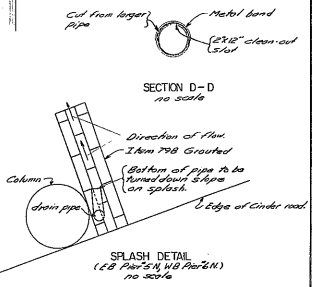
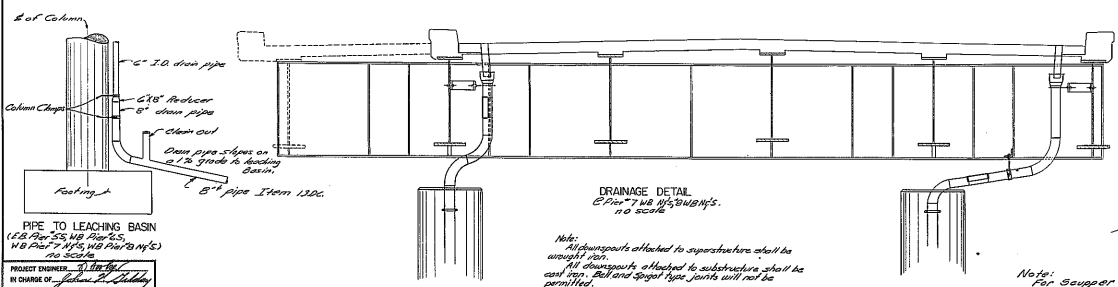
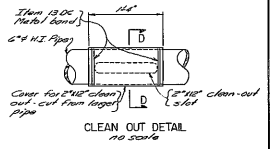
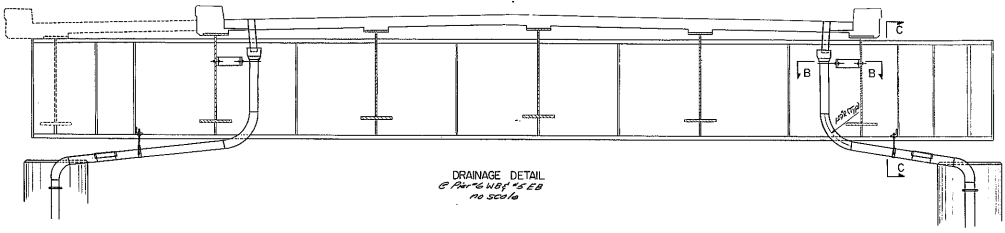
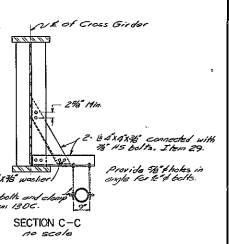
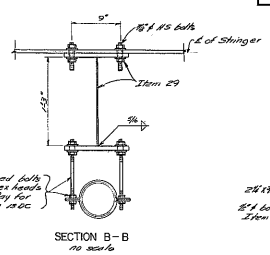
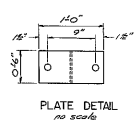
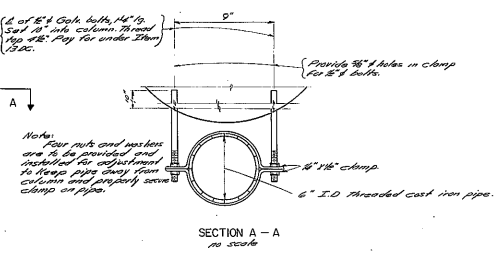
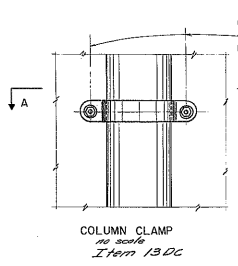
© E.B. Parson's, Inc. Pat. # 2,411,484 Pat. # 2,411,485 Pat. # 2,411,486 Pat. # 2,411,487 Pat. # 2,411,488 Pat. # 2,411,489 Pat. # 2,411,490 Pat. # 2,411,491 Pat. # 2,411,492 Pat. # 2,411,493 Pat. # 2,411,494 Pat. # 2,411,495 Pat. # 2,411,496 Pat. # 2,411,497 Pat. # 2,411,498 Pat. # 2,411,499 Pat. # 2,411,500

PROJECT ENGINEER: W. E. Kelly
 IN CHARGE OF: John P. Kelly
 DESIGNED BY: _____
 DESIGN CHECKED BY: _____
 DETAILS CHECKED BY: John P. Kelly
 DETAILS CHECKED BY: _____

DR. NO. 2
 SOUTHERN TIER EXPRESSWAY
 OVER BULL-LACKAWANNA R.R.
 APPROACH SLAB & SCUPPER
 DRAWING NO. 350 44



F.A.S.T.F. 67-4				
DIST. NO.	STATE	FEDERAL AID PROJECT NO.	SHEET NO.	TOTAL SHEETS
	NEW YORK	APD-221(217)	186	200
SOUTHERN TIER EXPRESSWAY, SECTION 68 LONGHAWTHORNE, PART 1 COLUMBIA COUNTY				



PIPE TO LEACHING BASIN
(E.B. Part 5, W.B. Part 5, W.B. Part 7, W.B. Part 9, W.B. Part 5)
no scale

PROJECT ENGINEER: *[Signature]*
IN CHARGE OF: *[Signature]*
DESIGNED BY: *[Signature]*
DESIGN CHECKED BY: *[Signature]*
DETAIL CHECKED BY: *[Signature]*

Note:
All downspouts attached to superstructure shall be wrought iron.
All downspouts attached to substructure shall be cast iron. Bell and Spout type joints will not be permitted.
All downspouts buried below ground surface shall be cast iron and may have Bell and Spout type joints.

Note:
For Sagger Detail see Dwg No. 55.

DR. NO. 2
SOUTHERN TIER EXPRESSWAY
OVER EARL-LAGRANDE R.R.
SOUTHERN TIER EXPRESSWAY - SUPPORTS & DRAINAGE
DRAWING NO. 36 OF 44

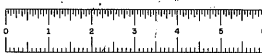


FIG. NO.	STATE	FEDERAL AID PROJECT NO.	SHEET NO.	TOTAL SHEETS
100	NEW YORK	APD-231(21)	199	200

SOUTHERN TIER EXPRESSWAY, SECTION 68
LAWRENCEVILLE, PART 1
COLUMBIA COUNTY

338 5S571 @ 48" c/c Top of slab 338 5S572 @ 48" c/c Bot of slab 254 5S571 @ 14" c/c in sidewalk	339 5S571 @ 48" c/c Top of slab 339 5S572 @ 48" c/c Bot of slab 252 5S571 @ 14" c/c in sidewalk	340 5S571 @ 48" c/c Top of slab 340 5S572 @ 48" c/c Bot of slab 252 5S571 @ 14" c/c in sidewalk	340 5S571 @ 48" c/c Top of slab 340 5S572 @ 48" c/c Bot of slab 248 5S571 @ 14" c/c in sidewalk	339 5S571 @ 48" c/c Top of slab 339 5S572 @ 48" c/c Bot of slab 252 5S571 @ 14" c/c in sidewalk
Note: Long bars in this span are 5S541, 5S542 and 5S541 bars lapped in 3 lengths of 48" with a min. lap of 14" for location see Dwg. #26.	Note: Long bars in this span are 5S541, 5S542 and 5S541 bars lapped in 3 lengths of 48" with a min. lap of 14" for location see Dwg. #26.	Note: Long bars in this span are the same as span 2.	Note: Long bars in this span are 5S541, 5S542 and 5S541 bars lapped in 3 lengths of 48" with a min. lap of 14" for location see Dwg. #26.	Note: Long bars in this span are the same as span 2.

Slab begins 56.28+56.72 E of Improp.

SPAN 1	SPAN 2	SPAN 3	SPAN 4	SPAN 5
333 5S571 @ 48" c/c Top of slab 333 5S572 @ 48" c/c Bot of slab 250 5S571 @ 14" c/c in sidewalk	335 5S571 @ 48" c/c Top of slab 335 5S572 @ 48" c/c Bot of slab 252 5S571 @ 14" c/c in sidewalk	340 5S571 @ 48" c/c Top of slab 340 5S572 @ 48" c/c Bot of slab 248 5S571 @ 14" c/c in sidewalk	327 5S571 @ 48" c/c Top of slab 327 5S572 @ 48" c/c Bot of slab 246 5S571 @ 14" c/c in sidewalk	
Note: Long bars in this span are 5S541, 5S542 and 5S541 bars lapped in 3 lengths of 48" with a min. lap of 14" for location see Dwg. #26.	Note: Long bars in this span are 5S541, 5S542 and 5S541 bars lapped in 3 lengths of 48" with a min. lap of 14" for location see Dwg. #26.	Note: Long bars in this span are the same as span 4.	Note: Long bars in this span are 5S541, 5S542 and 5S541 bars lapped in 3 lengths of 48" with a min. lap of 14" for location see Dwg. #26.	Slab ends 56.94+57.06

SLAB BAR LAYOUT WESTBOUND Scale: 1"=20'-0"

338 5S571 @ 48" c/c Top of slab 338 5S572 @ 48" c/c Bot of slab 254 5S571 @ 14" c/c in sidewalk	339 5S571 @ 48" c/c Top of slab 339 5S572 @ 48" c/c Bot of slab 252 5S571 @ 14" c/c in sidewalk	340 5S571 @ 48" c/c Top of slab 340 5S572 @ 48" c/c Bot of slab 252 5S571 @ 14" c/c in sidewalk	339 5S571 @ 48" c/c Top of slab 339 5S572 @ 48" c/c Bot of slab 252 5S571 @ 14" c/c in sidewalk	333 5S571 @ 48" c/c Top of slab 333 5S572 @ 48" c/c Bot of slab 250 5S571 @ 14" c/c in sidewalk
Note: Long bars in this span are the same as span 1 Westbound.	Note: Long bars in this span are the same as span 2 Westbound.	Note: Long bars in this span are the same as span 2 Westbound.	Note: Long bars in this span are the same as span 2 Westbound.	Note: Long bars in this span are 5S541, 5S542 and 5S541 bars lapped in 3 lengths of 48" with a min. lap of 14" for location see Dwg. #26.

Slab begins 56.94+57.06 E of Improp.

322 5S571 @ 48" c/c Top of slab 322 5S572 @ 48" c/c Bot of slab 248 5S571 @ 14" c/c in sidewalk	321 5S571 @ 48" c/c Top of slab 321 5S572 @ 48" c/c Bot of slab 248 5S571 @ 14" c/c in sidewalk	320 5S571 @ 48" c/c Top of slab 320 5S572 @ 48" c/c Bot of slab 248 5S571 @ 14" c/c in sidewalk
Note: Long bars in this span are 5S541, 5S542 and 5S541 bars lapped in 3 lengths of 48" with a min. lap of 14" for location see Dwg. #26.	Note: Long bars in this span are 5S541, 5S542 and 5S541 bars lapped in 3 lengths of 48" with a min. lap of 14" for location see Dwg. #26.	Note: Long bars in this span are 5S541, 5S542 and 5S541 bars lapped in 3 lengths of 48" with a min. lap of 14" for location see Dwg. #26.

Note: Concrete of the slab from West to East.

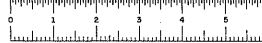
Slab ends 56.94+57.06

Note: Reinforcement details see Dwg. #28

SLAB BAR LAYOUT EASTBOUND Scale: 1"=20'-0"

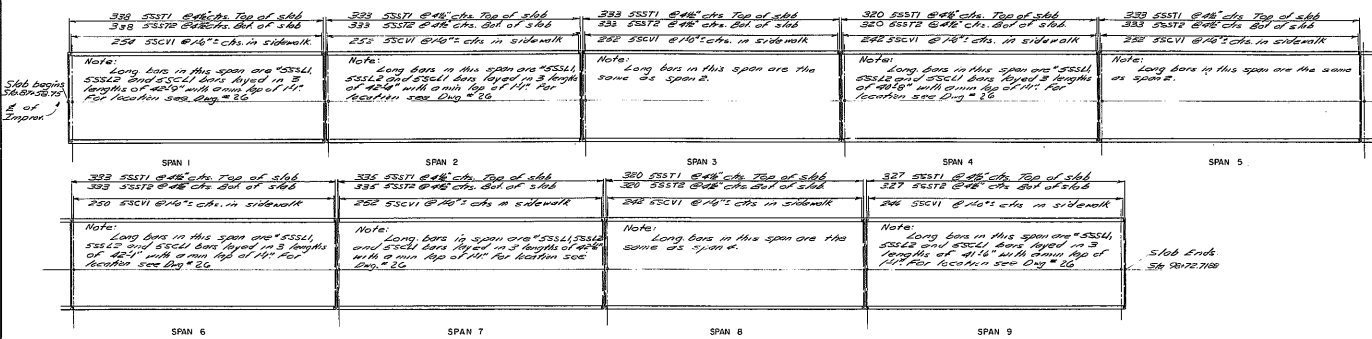
PROJECT ENGINEER: [Signature]
 IN CHARGE OF: [Signature]
 DESIGNED BY: [Signature]
 DESIGN CHECKED BY: [Signature]
 DETAILED BY: [Signature]
 CHECKED BY: [Signature]

DR. NO. 2
 SOUTHERN TIER EXPRESSWAY
 OVER EAST-LAKEMANNA R.R.
 SLAB BAR LAYOUT
 EASTBOUND & WESTBOUND
 DRAWING NO. 37 OF 44

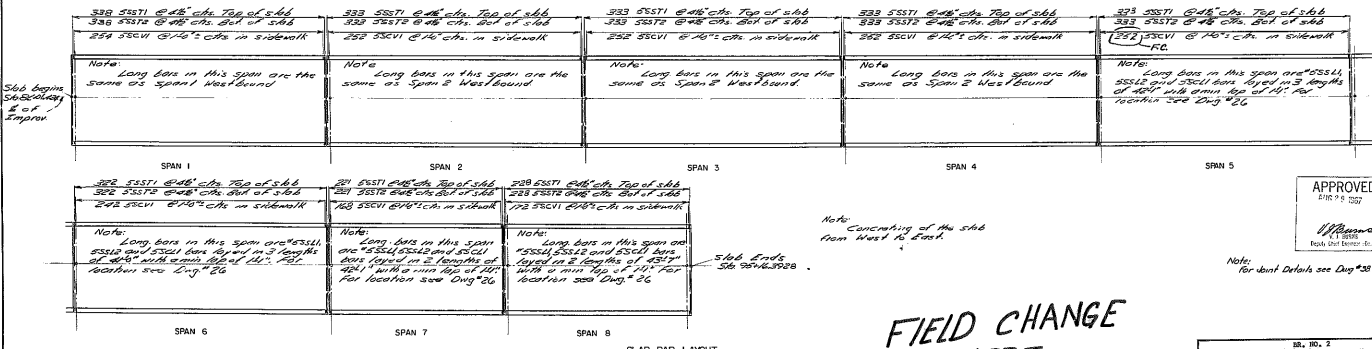


JOB NO.	STATE	PROJECT NO.	SHEET NO.	TOTAL SHEETS
NEW YORK	ADD 311(21)		1371	200

SOUTHERN TIER EXPRESSWAY, SECTION 6R
LONGHUB-MATZELY, PART 1
OSWEGO COUNTY



SLAB BAR LAYOUT WESTBOUND Scale 1"=20'-0"



SLAB BAR LAYOUT EASTBOUND Scale 1"=20'-0"

PROJECT ENGINEER: J. J. [Signature]
 IN CHARGE OF: [Signature]
 DESIGNED BY: [Signature]
 DESIGN CHECKED BY: [Signature]
 DETAILED BY: [Signature]
 DETAIL CHECKED BY: [Signature]

APPROVED
 [Signature]
 [Signature]
 [Signature]
 For detail Details see Day 28

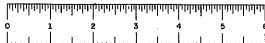
Note: Curbing of the slab from West to East.

Slab Ends Sta 50+00.3500

FIELD CHANGE SHEET.

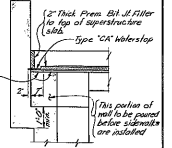
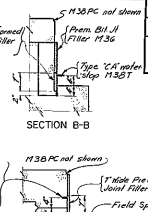
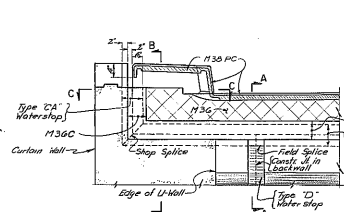
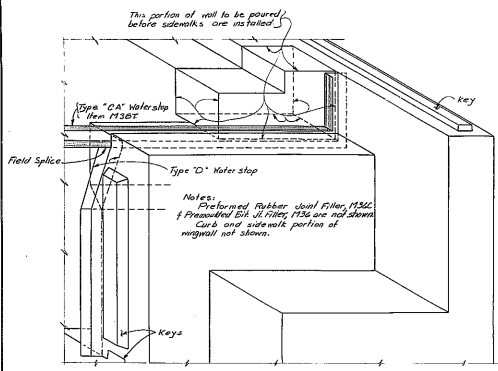
Note: Field change indicated FC.

SS, RD. 2
 SOUTHERN TIER EXPRESSWAY
 OVER BELLEGARDEMAN T.B.L.
 SLAB BAR LAYOUT
 EASTBOUND & WESTBOUND
 DRAWING NO. 57 of 44



FILE NO.	STATE	PROJECT NO.	SHEET NO.	TOTAL SHEETS
NEW YORK	APD-221(21)	138	2.00	

SOUTHERN TIER EXPRESSWAY, SECTION 08
 SOKOMI-MAZZELLI, PART 1
 CROWN CANYON

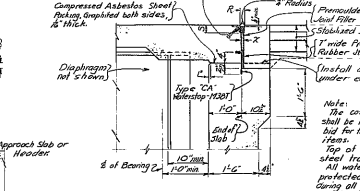


SECTION LOOKING TOWARD SUPERSTRUCTURE

Notes: No holes may be made in the waterstop for any purpose. Exposed waterstop must be protected from damage by suitable means during all phases of construction. All sections shall be checked against the field splicing shall be approved by Deputy Chief Engineer, Design. Give Preformed Rubber Joint Filler to waterstop with Goodyear Plabond or Weldbond Contact Cement.

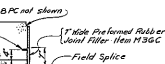
INSTALLATION OF WATERSTOPS

Notes: Saw recess for Preformed Elastic Joint Sealer not less than 8 days after placing concrete, and before side wall concrete is poured.

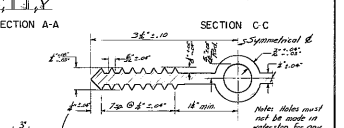


JOINT AT ABUTMENT

Notes: The cost of oil joint sealant shall be included in the price bid for the concrete items. Top of sealant shall be steel trowel finished. All waterstops must be protected from damage during all phases of construction.

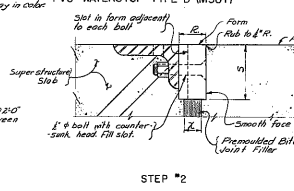
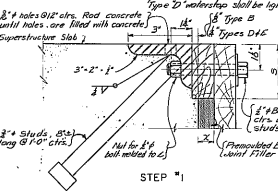
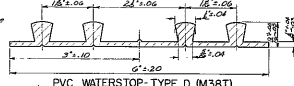


CUTTING AND BENDING SEAL



INSTALLATION OF WATERSTOPS

Notes: Water holes must not be made in waterstop for any purpose except as required for locking the forms. Decking to forms will only be permitted if the area between the waterstop ribs and the edges of waterstop.



- CONSTRUCTION PROCEDURE**
1. Bolt nipples to form boards as indicated in step #1 to proper line and grade.
 2. Pour Superstructure slab.
 3. Remove forms and bolts.
 4. Place form as indicated in step #2.
 5. Pour approach slab.
 6. Cut off bolt flush with angle with saw; saw.
 7. Remove form and replace with Preformed Elastic Joint Sealer.

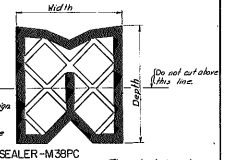
Notes: 3\"/>

END CONDITION	TYPE	R	S	K	T
Fixed	B	1'	3'	1'	1'
Exp-Bolt to 100'	D	18'	38'	1'	1'
Exp-Bolt to 125'	E	18'	38'	1'	1'

Dimensions for Types B, D & E

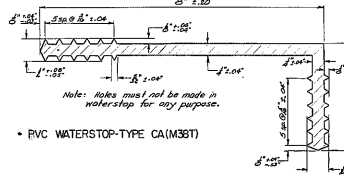
TYPE	WIDTH	DEPTH	THICKNESS
B	12"	2 1/2"	1/2"
D	24"	2 1/2"	1/2"
E	36"	2 1/2"	1/2"

Any changes in the slope or dimensions of preformed elastic joint sealer must be approved by the Deputy Chief Engineer Design. The minimum thickness of any metal shall not be less than as specified. The average thickness of oil seals shall be within the tolerances specified.



DETAILS OF ARMORING ANGLE AT ABUTMENTS

Notes: 3\"/>

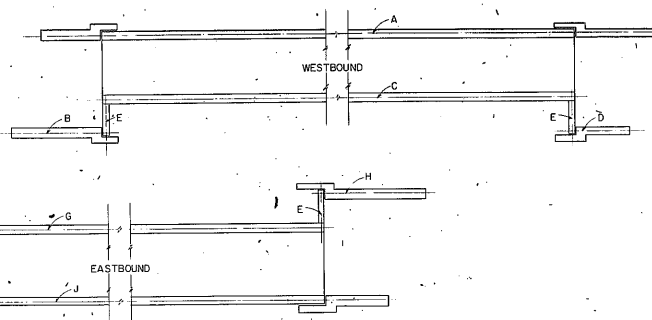


PROJECT ENGINEER: *[Signature]*
 IN CHARGE OF: *[Signature]*
 DESIGNED BY: *[Signature]*
 DESIGN CHECKED BY: *[Signature]*
 DRAWN BY: *[Signature]*
 DETAIL CHECKED BY: *[Signature]*

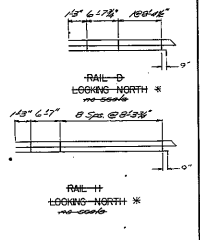
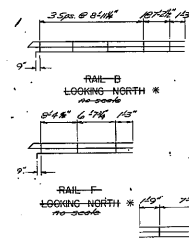
DR. NO. 3
 SOUTHERN TIER EXPRESSWAY
 OVER BELLS-LOCKHARTER R.R.
WATERSTOP & JOINT DETAILS
 DRAWING NO. 38 OF 44

FED. NO.	STATE	FEDERAL PROJECT NO.	SHEET NO.	TOTAL SHEETS
	NEW YORK	140-31 (51)	109	199

SOUTHERN TIER EXPRESSWAY, SECTION 68
 LOCATED NANTZELLY, CHEROKEE COUNTY

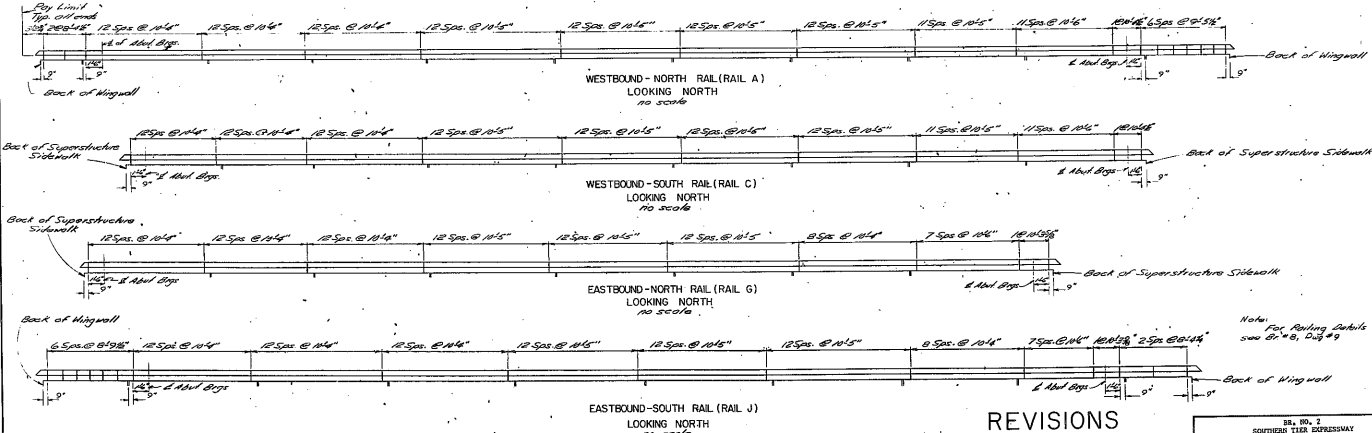


RAILING LAYOUT SCHEMATIC
no scale



RAIL-E
4 REQUIRED *

* NOTE: DELETED SEE AMENDMENT NO. 2 PROPOSAL (7-18-67)

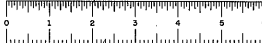


REVISIONS

1. RAILS B,D,E,F,H DELETED

PROJECT ENGINEER: *[Signature]*
 IN CHARGE OF: *[Signature]*
 DESIGNED BY: *[Signature]*
 CHECKED BY: *[Signature]*
 DETAIL CHECKED BY: *[Signature]*

RAILING LAYOUT
 EASTBOUND & WESTBOUND
 DRAWING NO. 37 OF 44

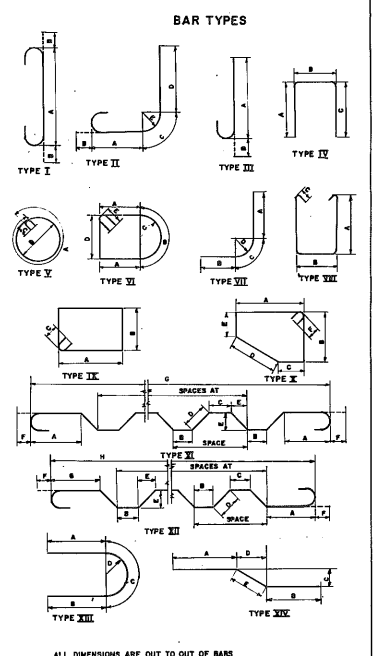


FED. RD. DIST. NO.	STATE	FEDERAL AID PROJ. CT NO.	SHEET NO.	TOTAL SHEETS
	N.Y.	APD-221(11)	140	200

CONTRACT TITLE: EXPRESSWAY, SECTION 08
LONG-HAVENLY, PART 1
CROSSLING COUNTY

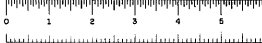
WEST ABUTMENT									
MARK	SIZE NO.	LENGTH	TYPE	LOCATION					
				A	B	C	D	E	F
SAFT1	5	31	6'-4"	Str.					Transverse in Top of footing
SAFT2	5	72	6'-4"	Str.					Trans. in T & B W/W footings
SAFT3	7	61	6'-8"	Str.					Transverse in Bolt of footing
SAFL1	5	24	2'-9"	Str.					Long. in T & B of footing
SAFL2	5	10	2'-9"	Str.					Long. in T & B W/W footing
SAFL3	5	10	2'-9"	Str.					Long. in T & B W/W footing
SAFL4	5	10	2'-9"	Str.					Long. in T & B W/W footing
SAFL5	5	10	2'-9"	Str.					Long. in T & B W/W footing
SAFL6	5	84	3'-7"	Str.					Dowels in Fr & Bk of W/W footing
SAFS1	5	20	10'-0"	Str.	3'-0"	3'-2"	3'-0"		Strutts in Interior Pedestal
SAFS2	5	5	11'-8"	Str.	3'-0"	4'-0"	3'-0"		Strutts in Faccia Pedestal
SAFS3	5	5	9'-8"	Str.	3'-0"	2'-0"	3'-0"		Strutts in Faccia Pedestal
SAPV1	5	20	6'-1"	Str.					Vertical in Pedestal
SAPV2	5	28	28'-11"	Str.					Vertical in Fr & Bk of stem
SAPV3	5	84	4'-8"	Str.					Vertical in Fr & Bk of Wingwall
SAPV4	5	18	5'-8"	Str.					Horizontal in Fr of Curtain Walls
SAPV5	5	11	19'-0"	Str.					Horizontal in Fr of Wingwall
SAPV6	5	8	12'-9"	Str.					Horizontal in Bk of Wingwall
SAPV7	5	8	21'-2"	Str.					Horizontal in Bk of Wingwall
SAPV8	5	8	17'-4"	Str.					Horizontal in Bk of Wingwall
SAPV9	5	18	18'-8"	Str.					Horizontal in Fr & Bk of W/W & W/W overlay
SAPV10	5	10	4'-8"	Str.	2'-1"	8"	2'-1"		Strutts in Curtain Wall
SAPV11	5	4	9'-2"	Str.					Horizontal in T & B Header
SAPV12	5	4	9'-2"	Str.					Horizontal in T & B Header
SAPV13	5	4	3'-0"	Str.					Horizontal in T & B Header (Fr & Bk)
SAPV14	5	4	11'-8"	Str.					Strutts in header
SAPV15	5	4	6'-0"	Str.	3'-2"	6"	3'-2"		Strutts in header
SAPV16	5	4	6'-0"	Str.	3'-0"	6"	3'-0"		Strutts in header
SAPV17	5	7	9'-0"	Str.	3'-0"	6"	3'-0"		Strutts in header
SACL1	5	1	17'-0"	Str.					Longitudinal in S.W. overlay
SACL2	5	1	17'-0"	Str.					Longitudinal in S.W. overlay
SACT1	5	51	1'-1"	Str.					Transverse in S.W. overlay

EAST ABUTMENT									
MARK	SIZE NO.	LENGTH	TYPE	LOCATION					
				A	B	C	D	E	F
SAFT1	5	31	6'-4"	Str.					Transverse in Top of footing
SAFT2	5	102	6'-4"	Str.					Trans. in T & B of W/W footing
SAFT3	7	31	6'-8"	Str.					Trans. in Bolt of footing
SAFL1	5	24	2'-9"	Str.					Longitudinal in T & B of footing
SAFL2	5	10	2'-9"	Str.					Long. in T & B of W/W footing
SAFL3	5	10	2'-9"	Str.					Long. in T & B of W/W footing
SAFL4	5	10	2'-9"	Str.					Long. in T & B of W/W footing
SAFL5	5	10	2'-9"	Str.					Long. in T & B of W/W footing
SAFL6	5	10	2'-9"	Str.					Long. in T & B of W/W footing
SAFL7	5	84	3'-7"	Str.					Dowels in Fr & Bk of footing
SAFL8	5	144	3'-7"	Str.					Dowels in Fr & Bk of W/W footing
SAFS1	5	20	10'-0"	Str.	3'-0"	3'-2"	3'-0"		Strutts in Interior Pedestal
SAFS2	5	5	11'-8"	Str.	3'-0"	4'-0"	3'-0"		Strutts in Faccia Pedestal
SAFS3	5	5	9'-8"	Str.	3'-0"	2'-0"	3'-0"		Strutts in Faccia Pedestal
SAPV1	5	20	6'-1"	Str.					Vertical in Pedestal
SAPV2	5	28	28'-11"	Str.					Vertical in Fr & Bk of stem
SAPV3	5	84	4'-8"	Str.					Vertical in Fr & Bk of Wingwall
SAPV4	5	18	5'-8"	Str.					Horizontal in Fr of Curtain Walls
SAPV5	5	11	19'-0"	Str.					Horizontal in Fr of Wingwall
SAPV6	5	8	12'-9"	Str.					Horizontal in Bk of Wingwall
SAPV7	5	8	21'-2"	Str.					Horizontal in Bk of Wingwall
SAPV8	5	8	17'-4"	Str.					Horizontal in Bk of Wingwall
SAPV9	5	18	18'-8"	Str.					Horizontal in Fr & Bk of W/W & W/W overlay
SAPV10	5	10	4'-8"	Str.	2'-1"	8"	2'-1"		Strutts in Curtain Wall
SAPV11	5	4	9'-2"	Str.					Horizontal in T & B of header
SAPV12	5	4	9'-2"	Str.					Horizontal in T & B of header
SAPV13	5	4	3'-0"	Str.					Horizontal in T & B of header (Fr & Bk)
SAPV14	5	4	11'-8"	Str.					Strutts in header
SAPV15	5	4	6'-0"	Str.	3'-2"	6"	3'-2"		Strutts in header
SAPV16	5	4	6'-0"	Str.	3'-0"	6"	3'-0"		Strutts in header
SAPV17	5	7	9'-0"	Str.	3'-0"	6"	3'-0"		Strutts in header
SACL1	5	1	17'-0"	Str.					Longitudinal in S.W. overlay
SACL2	5	1	17'-0"	Str.					Longitudinal in S.W. overlay
SACT1	5	51	1'-1"	Str.					Transverse in S.W. overlay



PROJECT CHECKED BY: *[Signature]*
 IN CHARGE OF: *[Signature]*
 DESIGNED BY:
 DESIGN CHECKED BY:
 DETAIL CHECKED BY: *[Signature]*

BL. NO. 2
 GOVERNMENT TIER EXPRESSWAY
 OVER BLUE-LACONIA R.R.
 WESTBOUND
 EAST & WEST ABUTMENT
 BAR LIST
 DRAWING NO. 606P-44



WEST ABUTMENT											
MARK	SIZE	NO.	LENGTH	TYPE	A	B	C	D	E	F	LOCATION
SAFT1	5	31	6'-4"	Sir.							Transverse in Top of footing
SAFT2	5	32	6'-4"	Sir.							Trans. in T & B of WW footing
SAFT3	7	31	6'-8"	Sir.							Trans. in Bolt of footing
SAFL1	5	24	24'-0"	Sir.							Longitudinal in T & B of footing
SAFL2	5	10	23'-5"	Sir.							Long. in T & B of WW footing
SAFL3	5	10	22'-0"	Sir.							Long. in T & B of WW footing
SAFL4	5	10	18'-8"	Sir.							Long. in T & B of WW footing
SAFL5	5	88	2'-0"	Sir.							Dowels in Fr & Bk of footing
SAFL6	5	84	3'-7"	Sir.							Dowels in Fr & Bk of WW footing
SAPSI	5	20	10'-0"	IV	3'-0"	3'-2"	3'-0"				Stirrups in Inferior Pedestal
SAPSS	5	5	11'-8"	IV	3'-0"	4'-0"	3'-0"				Stirrups in Fascia Pedestal
SAPVI	5	20	10'-0"	IV	3'-0"	3'-2"	3'-0"				Vertical in Pedestal
SABVI	5	88	9'-0"	Sir.							Vertical in Fr & Bk of stem
SABHI	5	28	28'-11"	Sir.							Horizontal in Fr & Bk of stem
SABSI	5	34	4'-8"	Sir.							Vertical in Fr & Bk of Wingwall
SABHI	5	18	5'-8"	Sir.							Horizontal in Fr. of Curtain Walls
SABSI	5	18	18'-10"	Sir.							Horizontal in Fr. of Wingwall
SABSI	5	8	10'-8"	Sir.							Horizontal in Bk of Wingwall
SABSI	5	8	21'-2"	Sir.							Horizontal in Fr. of Wingwall
SABSI	5	8	17'-6"	Sir.							Horizontal in Bk of Wingwall
SABSI	5	8	18'-8"	Sir.							Horiz. in Fr & Bk of WW & WW overlay
SABSI	5	10	4'-8"	IV	2'-1"	8"	2'-1"				Stirrups in Curtainwall
SABSI	5	4	4'-2"	Sir.							Horizontal in T & B. Header
SABSI	5	4	9'-2"	Sir.							Horizontal in T & B. Header
SABSI	5	4	3'-2"	Sir.							Horizontal in T & B. Header (Fr & Bk)
SABSI	5	4	11'-8"	Sir.							Stirrups in header
SABSI	5	4	8'-0"	IV	3'-0"	6"	3'-0"				Stirrups in header
SABSI	5	1	16'-8"	Sir.							Longitudinal in S.W. overlay
SABSI	5	1	17'-8"	Sir.							Longitudinal in S.W. overlay
SABSI	5	53	1'-1"	Sir.							Transverse in S.W. overlay

EAST ABUTMENT											
MARK	SIZE	NO.	LENGTH	TYPE	A	B	C	D	E	F	LOCATION
SAFT1	5	31	6'-4"	Sir.							Transverse in Top of footing
SAFT2	5	102	6'-4"	Sir.							Trans. in T & B of WW footing
SAFT3	7	31	6'-8"	Sir.							Trans. in Bolt of footing
SAFL1	5	24	24'-0"	Sir.							Longitudinal in T & B of footing
SAFL2	5	10	23'-5"	Sir.							Long. in T & B of WW footing
SAFL3	5	10	22'-0"	Sir.							Long. in T & B of WW footing
SAFL4	5	10	20'-8"	Sir.							Long. in T & B of WW footing
SAFL5	5	10	20'-0"	Sir.							Long. in T & B of WW footing
SAPSI	5	20	10'-0"	IV	3'-0"	3'-2"	3'-0"				Dowels in Fr & Bk of WW footing
SAPSS	5	5	11'-8"	IV	3'-0"	4'-0"	3'-0"				Dowels in Fr & Bk of WW footing
SAPVI	5	20	10'-0"	IV	3'-0"	3'-2"	3'-0"				Stirrups in Inferior Pedestal
SAPSS	5	5	11'-8"	IV	3'-0"	4'-0"	3'-0"				Stirrups in Fascia Pedestal
SAPVI	5	20	10'-0"	IV	3'-0"	3'-2"	3'-0"				Stirrups in Fascia Pedestal
SABVI	5	88	9'-0"	Sir.							Vertical in Fr & Bk of stem
SABHI	5	28	28'-11"	Sir.							Horizontal in Fr & Bk of stem
SABSI	5	34	4'-8"	Sir.							Vertical in Fr & Bk of Wingwall
SABHI	5	18	5'-8"	Sir.							Horizontal in Fr. of Curtain Walls
SABSI	5	18	18'-10"	Sir.							Horizontal in Fr. of Wingwall
SABSI	5	8	10'-8"	Sir.							Horizontal in Bk of Wingwall
SABSI	5	8	21'-2"	Sir.							Horizontal in Fr. of Wingwall
SABSI	5	8	17'-6"	Sir.							Horizontal in Bk of Wingwall
SABSI	5	8	18'-8"	Sir.							Horiz. in Fr & Bk of WW & WW overlay
SABSI	5	10	4'-8"	IV	2'-1"	8"	2'-1"				Stirrups in Curtain Wall
SABSI	5	4	4'-2"	Sir.							Horizontal in T & B. Header
SABSI	5	4	9'-2"	Sir.							Horizontal in T & B. Header
SABSI	5	4	3'-2"	Sir.							Horizontal in T & B. Header (Fr & Bk)
SABSI	5	4	11'-8"	Sir.							Stirrups in header
SABSI	5	4	8'-0"	IV	3'-0"	6"	3'-0"				Stirrups in header
SABSI	5	1	16'-8"	Sir.							Longitudinal in S.W. overlay
SABSI	5	1	17'-8"	Sir.							Longitudinal in S.W. overlay
SABSI	5	14	1'-1"	Sir.							Transverse in S.W. overlay

STATE: N.Y. FEDERAL PROJECT NO.: APD-2210173 SHEET NO.: 1/10/71 TOTAL SHEETS: 200

SOUTHSHORE BIDA DOWNSWAY, SECTION 06 LONGWALK-HATFIELD PART 1A CHENANGO COUNTY

BAR TYPES

ALL DIMENSIONS ARE OUT TO OUT OF BARS

APPROVED
DATE: 2-9-1987
[Signature]

FIELD CHANGE SHEET

SS. No. 2
SOUTHWEST BIDA CORRIDORWAY
OVER BIDE-LAGHANARA R.R.

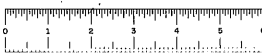
WESTBOUND
EAST & WEST ABUTMENT
BAR LIST

DRAWING NO. 1008 2-2

F.A.S.T.E. 67-4

PROJECT CHECKED BY: [Signature]
 IN CHARGE OF: [Signature]
 DESIGNED BY: [Signature]
 DESIGN CHECKED BY: [Signature]
 DETAIL CHECKED BY: [Signature]

Note: Due to field changes as indicated on Drawing No's. 10, 22, 43 and 44, the Estimate of Quantities for Item 28 shall be changed as follows:
 Westbound Structure: Net Increase +18,451 lb.
 Eastbound Structure: Net Increase +12,154 lb.
 Net Decrease 8,757 lb. Net Increase EB - 6,693 lb.



F.A.S.T.E. 67-4

EAST ABUTMENT

MARK	SIZE	NO.	LENGTH	TYPE	A	B	C	D	E	F	G	LOCATION
SAFL1	5	26	30'-0"	Str.								Longitudinal in T & B of footing
SAFL2	5	14	24'-0"	Str.								Long. in W.W. footing
SAFL3	5	14	23'-0"	Str.								Long. in W.W. footing
SAFL4	5	14	24'-0"	Str.								Long. in W.W. footing
SAFL5	5	14	24'-0"	Str.								Long. in W.W. footing
SAFL6	5	14	24'-0"	Str.								Long. in W.W. footing
SAFL7	5	24	8'-0"	Str.								Transverse in Top of footing
SAFL8	5	24	8'-0"	Str.								Trans. in Bot. of footing
SAFL9	5	145	3'-0"	Str.								Dowels in footing
SAFL10	5	43	9'-0"	Str.								Dowels in footing
SAFL11	11	64	6'-0"	Str.								Dowels in footing
SAFL12	3	80	14'-0"	Str.								Vertical in Fr. of W.W.
SAFL13	11	64	14'-0"	Str.								Vert. in Bk. of W.W.
SAFL14	3	45	13'-0"	Str.								Vert. in Fr. of stem
SAFL15	4	43	13'-0"	Str.								Vert. in Bk. of stem
SAFL16	5	20	8'-0"	Str.								Vert. in Pedestal
SAFL17	5	11	17'-0"	Str.								Horiz. in Bk. of W.W.
SAFL18	5	12	25'-0"	Str.								Horiz. in Fr. of W.W.
SAFL19	5	24	8'-0"	Str.								Horiz. in Fr. of W.W.
SAFL20	5	11	16'-0"	Str.								Horiz. in Bk. of W.W.
SAFL21	5	12	25'-0"	Str.								Horiz. in Fr. of W.W.
SAFL22	5	24	8'-0"	Str.								Horiz. in Fr. & Bk. of W.W.
SAFL23	5	40	28'-0"	Str.								Horiz. in Fr. & Bk. of stem
SAFL24	5	11	16'-0"	Str.								Horiz. in Fr. & Bk. of stem
SAFL25	5	32	10'-0"	Str.								Stirrups in Interior Pedestal
SAFL26	5	8	4'-0"	Str.								Stirrups in Fascia Pedestal
SAFL27	5	12	6'-0"	Str.								Stirrups in Headers
SAFL28	5	4	6'-0"	Str.								Stirrups in Headers
SAFL29	5	7	4'-0"	Str.								Stirrups in Headers
SAFL30	5	4	5'-0"	Str.								Horiz. in Headers
SAFL31	5	4	5'-0"	Str.								Horiz. in Headers
SAFL32	5	4	3'-0"	Str.								Horiz. in Headers
SAFL33	5	4	11'-0"	Str.								Horiz. in Headers
SAFL34	5	10	4'-0"	Str.								Stirrups in Curtain Wall
SACL1	5	1	16'-0"	Str.								Longitudinal in S.W. overlay
SACL2	5	1	17'-0"	Str.								Longitudinal in S.W. overlay
SACT1	5	97	1'-0"	Str.								Transverse in S.W. overlay
GAF1	6	184	8'-11"	Str.								Longitudinal in T & B of W.W. footing

PROJECT ENGINEER: *[Signature]*
 IN CHARGE OF: *[Signature]*
 DESIGNED BY: *[Signature]*
 CHECKED BY: *[Signature]*
 DETAIL BY: *[Signature]*
 FINAL CHECKED BY: *[Signature]*

F.A.S.T.E. 67-4

WEST ABUTMENT

MARK	SIZE	NO.	LENGTH	TYPE	A	B	C	D	E	F	G	LOCATION
SAFL1	5	26	30'-0"	Str.								Longitudinal in T & B of footing
SAFL2	5	14	24'-0"	Str.								Long. in W.W. footing
SAFL3	5	14	23'-0"	Str.								Long. in W.W. footing
SAFL4	5	14	24'-0"	Str.								Long. in W.W. footing
SAFL5	5	14	24'-0"	Str.								Long. in W.W. footing
SAFL6	5	14	24'-0"	Str.								Long. in W.W. footing
SAFL7	5	24	8'-0"	Str.								Transverse in Top of footing
SAFL8	5	24	8'-0"	Str.								Trans. in Bot. of W.W. footing
SAFL9	5	145	3'-0"	Str.								Dowels in footing
SAFL10	5	43	9'-0"	Str.								Dowels in footing
SAFL11	11	64	6'-0"	Str.								Dowels in footing
SAFL12	3	80	14'-0"	Str.								Vertical in Fr. of W.W.
SAFL13	11	64	14'-0"	Str.								Vert. in Bk. of W.W.
SAFL14	3	45	13'-0"	Str.								Vert. in Fr. of stem
SAFL15	4	43	13'-0"	Str.								Vert. in Bk. of stem
SAFL16	5	20	8'-0"	Str.								Vert. in Pedestal
SAFL17	5	11	17'-0"	Str.								Horiz. in Bk. of W.W.
SAFL18	5	12	25'-0"	Str.								Horiz. in Fr. of W.W.
SAFL19	5	24	8'-0"	Str.								Horiz. in Fr. of W.W.
SAFL20	5	11	16'-0"	Str.								Horiz. in Bk. of W.W.
SAFL21	5	12	25'-0"	Str.								Horiz. in Fr. of W.W.
SAFL22	5	24	8'-0"	Str.								Horiz. in Fr. & Bk. of W.W.
SAFL23	5	40	28'-0"	Str.								Horiz. in Fr. & Bk. of stem
SAFL24	5	11	16'-0"	Str.								Horiz. in Fr. & Bk. of stem
SAFL25	5	32	10'-0"	Str.								Stirrups in Interior Pedestal
SAFL26	5	8	4'-0"	Str.								Stirrups in Fascia Pedestal
SAFL27	5	12	6'-0"	Str.								Stirrups in Headers
SAFL28	5	4	6'-0"	Str.								Stirrups in Headers
SAFL29	5	7	4'-0"	Str.								Stirrups in Headers
SAFL30	5	4	5'-0"	Str.								Horiz. in Headers
SAFL31	5	4	5'-0"	Str.								Horiz. in Headers
SAFL32	5	4	3'-0"	Str.								Horiz. in Headers
SAFL33	5	4	11'-0"	Str.								Horiz. in Headers
SAFL34	5	10	4'-0"	Str.								Stirrups in Curtain Wall
SACL1	5	1	16'-0"	Str.								Longitudinal in S.W. overlay
SACL2	5	1	17'-0"	Str.								Longitudinal in S.W. overlay
SACT1	5	97	1'-0"	Str.								Transverse in S.W. overlay

F.A.S.T.E. 67-4

REC. NO.	STATE	FEDERAL PROJ. NO.	SHEET NO.	TOTAL SHEETS
	N.Y.	APD-231(21)	14/1	200

SOUTHERN TIER EXPRESSWAY, SECTION 08
 LONGMEAD-WATKINS, PART 1
 CROISSANT COUNTY

BAR TYPES

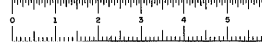
ALL DIMENSIONS ARE OUT TO OUT OF BARS

APPROVED
 11/17/03
[Signature]
 Detail

FIELD CHANGE SHEET

DR. NO. 2
 SOUTHERN TIER EXPRESSWAY
 OVER EBLE-LACKMANN R.R.
 EASTBOUND
 EAST 8. WEST ABUTMENT
 BAR LIST

DRAWING NO. 67-4
 F.A.S.T.E. 67-4

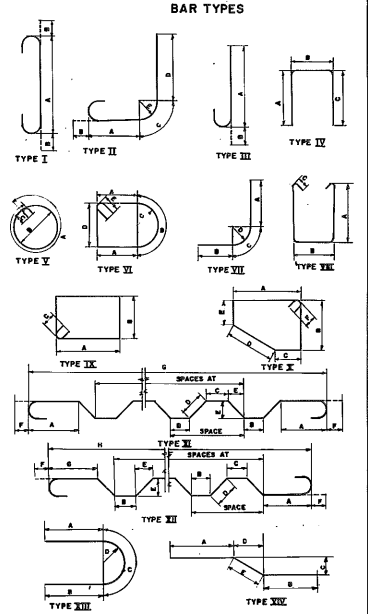


FED. NO.	STATE	FEDERAL AID PROJECT NO.	SHEET NO.	TOTAL SHEETS
NY.	APD-231(21)	142	200	

SOUTHERN TIER EXPRESSWAY, SECTION 68
EASTBOUND, PART 1
CHENGO COUNTY

MARK	SIZE	NO.	LENGTH	TYPE	A	B	C	D	E	F	G	LOCATION
BPT1	8	36	1144"	I	364	14"						Pier #1 West
BPT2	8	36	1144"	I	364	14"						Trans. Bot. Ptg.
BPT3	8	36	1144"	I	364	14"						Long. Bot. Ptg.
BPT4	8	36	1144"	I	364	14"						Work in N/S Pkg. Col
BPT5	8	36	1144"	I	364	14"						Trans. Top Ptg.
BPT6	8	36	1144"	I	364	14"						Long. Top Ptg.
BPT7	8	36	1144"	I	364	14"						Work in N/S Col
BPT8	8	36	1144"	I	364	14"						Shrugs in Col.

MARK	SIZE	NO.	LENGTH	TYPE	A	B	C	D	E	F	G	LOCATION
BPT1	8	36	1144"	I	364	14"						Pier #2
BPT2	8	36	1144"	I	364	14"						Trans. Bot. Ptg.
BPT3	8	36	1144"	I	364	14"						Long. Bot. Ptg.
BPT4	8	36	1144"	I	364	14"						Work in N/S Pkg. Col
BPT5	8	36	1144"	I	364	14"						Trans. Top Ptg.
BPT6	8	36	1144"	I	364	14"						Long. Top Ptg.
BPT7	8	36	1144"	I	364	14"						Work in N/S Col
BPT8	8	36	1144"	I	364	14"						Shrugs in Col.



ALL DIMENSIONS ARE OUT TO OUT OF BARS

PROJECT ENGINEER: *[Signature]*
 IN CHARGE: *[Signature]*
 DESIGNED BY:
 DESIGN CHECKED BY:
 DETAILED BY:
 DETAIL CHECKED BY:

R. NO. 3
 SOUTHERN TIER EXPRESSWAY
 OVER ERIC LACKMANN'S R.R.
 WESTBOUND & EASTBOUND
 PIERS & FOOTINGS
 BAR LIST
 DRAWING NO. 22 OF 44



MARK	SIZE	NO.	LENGTH	TYPE	A	B	C	D	E	F	G	LOCATION
<i>Bar 5 (Cont)</i>												
92571	9	32	175"	2	148"	145"						Temp. Set of Fly
92572	8	32	235"	2	118"	115"						Temp. " "
92573	5	32	148"	5A								Temp. " "
92574	5	32	148"	5A								Temp. " "
92575	10	32	235"	5A								Temp. in 1/2" Fly Col.
92576	10	32	235"	5A								Temp. in 1/2" Fly Col.
92577	3	32	145"	2	118"	115"	4"					Straps in Col.
<i>Bar 6</i>												
92578	9	32	148"	2	148"	145"						Temp. Set of Fly
92579	5	32	148"	2	118"	115"						Temp. " "
92580	10	32	235"	5A								Temp. in 1/2" Fly Col.
92581	5	32	148"	5A								Temp. in 1/2" Fly Col.
92582	11	32	235"	5A								Temp. " "
92583	11	32	235"	5A								Temp. " "
92584	10	32	235"	5A								Temp. in 1/2" Fly Col.
92585	3	32	145"	2	118"	115"	4"					Straps in Col.
<i>Bar 7</i>												
92586	5	32	148"	2	148"	145"						Temp. Set of Fly
92587	5	32	148"	2	118"	115"						Temp. " "
92588	10	32	235"	5A								Temp. in 1/2" Fly Col.
92589	5	32	148"	5A								Temp. in 1/2" Fly Col.
92590	11	32	235"	5A								Temp. " "
92591	11	32	235"	5A								Temp. " "
92592	10	32	235"	5A								Temp. in 1/2" Fly Col.
92593	3	32	145"	2	118"	115"	4"					Straps in Col.

MARK	SIZE	NO.	LENGTH	TYPE	A	B	C	D	E	F	G	LOCATION
------	------	-----	--------	------	---	---	---	---	---	---	---	----------

PROJECT ENGINEER *D. J. [Signature]*
 IN CHARGE OF *[Signature]*
 DESIGNED BY
 CHECKED BY
 DETAILED BY *[Signature]*
 CHECKED BY *[Signature]*

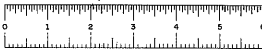
FED. NO.	STATE	FEDERAL AID PROJECT NO.	SHEET NO.	TOTAL SHEETS
	N.Y.	APD-221(21)	14-3	100

SOUTHERN BIRK CONCRETE, SECTION 68
 LONGHAWK, PART 1
 GREENBURY COUNTY

BAR TYPES

ALL DIMENSIONS ARE OUT TO OUT OF BARS

BL. NO. 3
 SOUTHERN BIRK CONCRETE
 OVER BIRK-LAGANARA B.B.
 WESTBOUND & EASTBOUND
 PERS. & FOOTINGS
 BAR LIST
 DRAWING NO. 67-4



FA.S.T.E. 67-4

FA.S.T.E. 67-4

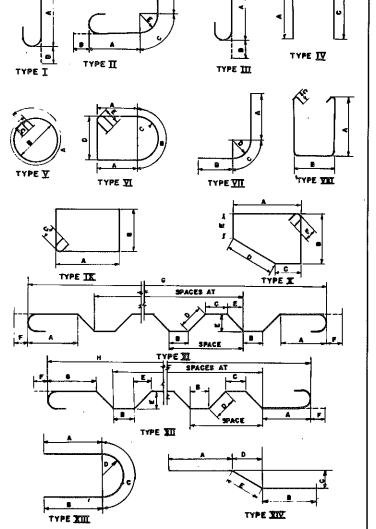
MARK	SIZE	NO.	LENGTH	TYPE	A	B	C	D	E	F	G	LOCATION
CC	D27L	9	36	1/2"	1/2"	1/2"						Lamp. Below Fly
CC	D27L	8	32	3/4"	3/4"	3/4"						Trans. " "
CC	D27L	5	28	1/2"	1/2"	1/2"						Trans. " "
CC	D27L	5	28	3/4"	3/4"	3/4"						Trans. " "
CC	D27L	10	34	1/2"	1/2"	1/2"						Trans. in Fly P.C.A.
CC	D27L	16	44	3/4"	3/4"	3/4"						Trans. on E.C.B.
CC	D27L	8	32	1/2"	1/2"	1/2"						Straps on E.C.B.
CC	D27L	9	36	1/2"	1/2"	1/2"						Pair " "
CC	D27L	8	32	3/4"	3/4"	3/4"						Trans. Below Fly
CC	D27L	12	48	3/4"	3/4"	3/4"						Trans. " "
CC	D27L	12	48	1/2"	1/2"	1/2"						Trans. in Fly P.C.A.
CC	D27L	8	32	1/2"	1/2"	1/2"						Trans. Top Fly
CC	D27L	11	44	3/4"	3/4"	3/4"						Trans. " "
CC	D27L	11	44	1/2"	1/2"	1/2"						Trans. " "
CC	D27L	10	40	3/4"	3/4"	3/4"						Trans. on E.C.B.
CC	D27L	3	62	1/2"	1/2"	1/2"						Straps on E.C.B.
CC	D27L	5	28	1/2"	1/2"	1/2"						Pair " "
CC	D27L	5	28	3/4"	3/4"	3/4"						Trans. Below Fly
CC	D27L	10	34	1/2"	1/2"	1/2"						Trans. " "
CC	D27L	11	44	3/4"	3/4"	3/4"						Trans. Top Fly
CC	D27L	11	44	1/2"	1/2"	1/2"						Trans. " "
CC	D27L	10	40	3/4"	3/4"	3/4"						Trans. in Fly P.C.A.
CC	D27L	10	40	1/2"	1/2"	1/2"						Trans. " "
CC	D27L	3	62	1/2"	1/2"	1/2"						Straps on E.C.B.
CC	G3V1	6	143	7/8"	7/8"	7/8"						Abutment + Pier Footing (Both Sides)
CC	G3V1	6	143	7/8"	7/8"	7/8"						Abutment + Pier Footing (Both Sides)

MARK	SIZE	NO.	LENGTH	TYPE	A	B	C	D	E	F	G	LOCATION
------	------	-----	--------	------	---	---	---	---	---	---	---	----------

FED. NO.	STATE	FEDERAL NO.	SHEET NO.	TOTAL SHEETS
REG. NO.	N.Y.	APD-321 (21)	143-A-200	

SOUTHERN TIER EXPRESSWAY, SECTION 6R
 LIONN-MAVER, PART 1
 CENSUS COUNTY

BAR TYPES



ALL DIMENSIONS ARE OUT TO OUT OF BARS
 APPROVED
 [Signature]
 DATE

SH. NO. 2
 SOUTHERN TIER EXPRESSWAY
 OVER DE-LAGANNAH R.R.
 WESTBOUND & EASTBOUND
 PIERS & FOOTINGS
 BAR LIST
 DRAWING NO. 13 OF 46

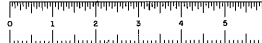
PROJECT ENGINEER: J. J. [Signature]
 IN CHARGE: [Signature]
 DESIGNED BY: [Signature]
 DESIGN CHECKED BY: [Signature]
 DETAILED BY: [Signature]
 CHECKED BY: [Signature]

Note: CC indicates Field Change in the type.

FIELD CHANGE SHEET

FA.S.T.E. 67-4

FA.S.T.E. 67-4



MARK	SIZE	NO.	LENGTH	TYPE	A	B	C	D	E	F	G	LOCATION
SPAN I (WEST)												
SSST1	5	230	48 1/2"	I		48 1/2"	7"					Hooked Bars in Top of Slab
SSST2	5	230	48 1/2"	S				48 1/2"	7"			Slab Bars on Bed of Slab
SSST3	5	230	48 1/2"	S					48 1/2"	7"		Slab Bars in Sidewalk
SSST4	5	12	48 1/2"	S						48 1/2"	7"	Loop in Sidewalk
SSST5	5	90	48 1/2"	S							48 1/2"	Loop Top of Slab
SSST6	5	192	48 1/2"	S							48 1/2"	Loop Bot of Slab
SPAN 2, 3&4												
SSST7	5	500	48 1/2"	I		48 1/2"	7"					Hooked Bars in Top of Slab
SSST8	5	500	48 1/2"	S				48 1/2"	7"			Slab Bars on Bed of Slab
SSST9	5	200	48 1/2"	S					48 1/2"	7"		Slab Bars in Sidewalk
SSST10	5	26	48 1/2"	S						48 1/2"	7"	Loop in Sidewalk
SSST11	5	270	48 1/2"	S							48 1/2"	Loop Top of Slab
SSST12	5	576	48 1/2"	S							48 1/2"	Loop Bot of Slab
SPAN 5												
SSST13	5	333	48 1/2"	I		48 1/2"	7"					Hooked Bars in Top of Slab
SSST14	5	333	48 1/2"	S				48 1/2"	7"			Slab Bars on Bed of Slab
SSST15	5	200	48 1/2"	S					48 1/2"	7"		Slab Bars in Sidewalk
SSST16	5	10	48 1/2"	S						48 1/2"	7"	Loop in Sidewalk
SSST17	5	90	48 1/2"	S							48 1/2"	Loop Top of Slab
SSST18	5	192	48 1/2"	S							48 1/2"	Loop Bot of Slab
SPAN 6												
SSST19	5	522	48 1/2"	I		48 1/2"	7"					Hooked Bars in Top of Slab
SSST20	5	522	48 1/2"	S				48 1/2"	7"			Slab Bars on Bed of Slab
SSST21	5	200	48 1/2"	S					48 1/2"	7"		Slab Bars in Sidewalk
SSST22	5	10	48 1/2"	S						48 1/2"	7"	Loop in Sidewalk
SSST23	5	90	48 1/2"	S							48 1/2"	Loop Top of Slab
SSST24	5	192	48 1/2"	S							48 1/2"	Loop Bot of Slab
SPAN 7												
SSST25	5	521	48 1/2"	I		48 1/2"	7"					Hooked Bars in Top of Slab
SSST26	5	521	48 1/2"	S				48 1/2"	7"			Slab Bars on Bed of Slab
SSST27	5	200	48 1/2"	S					48 1/2"	7"		Slab Bars in Sidewalk
SSST28	5	10	48 1/2"	S						48 1/2"	7"	Loop in Sidewalk
SSST29	5	90	48 1/2"	S							48 1/2"	Loop Top of Slab
SSST30	5	192	48 1/2"	S							48 1/2"	Loop Bot of Slab
SPAN 8												
SSST31	5	522	48 1/2"	I		48 1/2"	7"					Hooked Bars in Top of Slab
SSST32	5	522	48 1/2"	S				48 1/2"	7"			Slab Bars on Bed of Slab
SSST33	5	200	48 1/2"	S					48 1/2"	7"		Slab Bars in Sidewalk
SSST34	5	10	48 1/2"	S						48 1/2"	7"	Loop in Sidewalk
SSST35	5	90	48 1/2"	S							48 1/2"	Loop Top of Slab
SSST36	5	192	48 1/2"	S							48 1/2"	Loop Bot of Slab
SPAN 9												
SSST37	5	522	48 1/2"	I		48 1/2"	7"					Hooked Bars in Top of Slab
SSST38	5	522	48 1/2"	S				48 1/2"	7"			Slab Bars on Bed of Slab
SSST39	5	200	48 1/2"	S					48 1/2"	7"		Slab Bars in Sidewalk
SSST40	5	10	48 1/2"	S						48 1/2"	7"	Loop in Sidewalk
SSST41	5	90	48 1/2"	S							48 1/2"	Loop Top of Slab
SSST42	5	192	48 1/2"	S							48 1/2"	Loop Bot of Slab
APPROACH SLAB (E) REQUIRED												
SART1	5	230	11 3/4"	S								Trans. Bot of Approach Slab
SART2	5	90	48 1/2"	S								Loop Top of Bot of Approach
SART3	5	90	36 3/4"	S								" " " "
SART4	5	90	36 3/4"	S								" " " "
SART5	5	90	36 3/4"	S								" " " "

MARK	SIZE	NO.	LENGTH	TYPE	A	B	C	D	E	F	G	LOCATION
SPAN I (EAST)												
SSST1	5	230	48 1/2"	I		48 1/2"	7"					Hooked Bars in Top of Slab
SSST2	5	230	48 1/2"	S				48 1/2"	7"			Slab Bars on Bed of Slab
SSST3	5	230	48 1/2"	S					48 1/2"	7"		Slab Bars in Sidewalk
SSST4	5	12	48 1/2"	S						48 1/2"	7"	Loop in Sidewalk
SSST5	5	90	48 1/2"	S							48 1/2"	Loop Top of Slab
SSST6	5	192	48 1/2"	S							48 1/2"	Loop Bot of Slab
SPAN 2, 3&4												
SSST7	5	500	48 1/2"	I		48 1/2"	7"					Hooked Bars in Top of Slab
SSST8	5	500	48 1/2"	S				48 1/2"	7"			Slab Bars on Bed of Slab
SSST9	5	200	48 1/2"	S					48 1/2"	7"		Slab Bars in Sidewalk
SSST10	5	26	48 1/2"	S						48 1/2"	7"	Loop in Sidewalk
SSST11	5	270	48 1/2"	S							48 1/2"	Loop Top of Slab
SSST12	5	576	48 1/2"	S							48 1/2"	Loop Bot of Slab
SPAN 5												
SSST13	5	333	48 1/2"	I		48 1/2"	7"					Hooked Bars in Top of Slab
SSST14	5	333	48 1/2"	S				48 1/2"	7"			Slab Bars on Bed of Slab
SSST15	5	200	48 1/2"	S					48 1/2"	7"		Slab Bars in Sidewalk
SSST16	5	10	48 1/2"	S						48 1/2"	7"	Loop in Sidewalk
SSST17	5	90	48 1/2"	S							48 1/2"	Loop Top of Slab
SSST18	5	192	48 1/2"	S							48 1/2"	Loop Bot of Slab
SPAN 6												
SSST19	5	522	48 1/2"	I		48 1/2"	7"					Hooked Bars in Top of Slab
SSST20	5	522	48 1/2"	S				48 1/2"	7"			Slab Bars on Bed of Slab
SSST21	5	200	48 1/2"	S					48 1/2"	7"		Slab Bars in Sidewalk
SSST22	5	10	48 1/2"	S						48 1/2"	7"	Loop in Sidewalk
SSST23	5	90	48 1/2"	S							48 1/2"	Loop Top of Slab
SSST24	5	192	48 1/2"	S							48 1/2"	Loop Bot of Slab
SPAN 7												
SSST25	5	521	48 1/2"	I		48 1/2"	7"					Hooked Bars in Top of Slab
SSST26	5	521	48 1/2"	S				48 1/2"	7"			Slab Bars on Bed of Slab
SSST27	5	200	48 1/2"	S					48 1/2"	7"		Slab Bars in Sidewalk
SSST28	5	10	48 1/2"	S						48 1/2"	7"	Loop in Sidewalk
SSST29	5	90	48 1/2"	S							48 1/2"	Loop Top of Slab
SSST30	5	192	48 1/2"	S							48 1/2"	Loop Bot of Slab
SPAN 8												
SSST31	5	522	48 1/2"	I		48 1/2"	7"					Hooked Bars in Top of Slab
SSST32	5	522	48 1/2"	S				48 1/2"	7"			Slab Bars on Bed of Slab
SSST33	5	200	48 1/2"	S					48 1/2"	7"		Slab Bars in Sidewalk
SSST34	5	10	48 1/2"	S						48 1/2"	7"	Loop in Sidewalk
SSST35	5	90	48 1/2"	S							48 1/2"	Loop Top of Slab
SSST36	5	192	48 1/2"	S							48 1/2"	Loop Bot of Slab

FED. RD. REG. NO.	STATE	FEDERAL PROJ. NO.	AD. SHEET NO.	TOTAL SHEETS
	N.Y.	APP-37 (21)	144	200
SOUTHERN EIS BROADWAY, TROJAN DRIVE, LEOHANN-HANZLICH, PART 1 CANTON COUNTY				

BAR TYPES

ALL DIMENSIONS ARE OUT TO OUT OF BARS

SR. NO. 3
SUPPORT TIER CROSSWAY
OVER EIS-CROSSING, E.I.A.

EASTBOUND & WESTBOUND
SUPERSTRUCTURE SLAB
BAR LIST

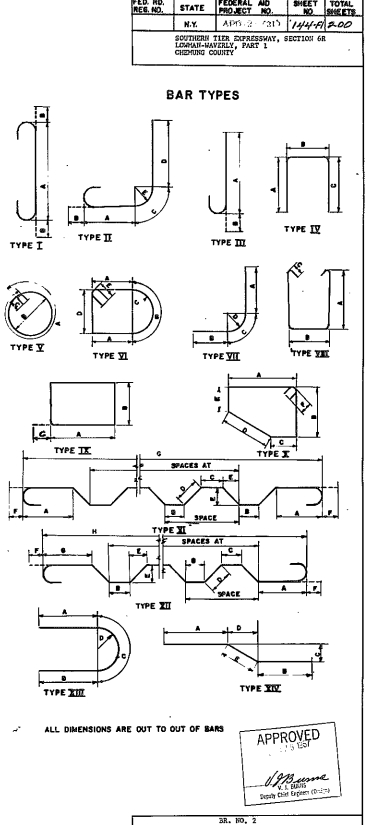
DRAWING NO. 44

PROJECT ENGINEER *J. J. Kelly*
IN CHARGE OF
DEPT. OF
DESIGN CHECKED BY *J. J. Kelly*
DETAIL CHECKED BY *J. J. Kelly*



MARK	SHE. NO.	LENGTH	TYPE	A	B	C	D	E	F	G	LOCATION	
SPAN 1 (WEST)												
RC	ESST1	5	338	48" x 24"	7	48" x 7"						Hooked Bars in Top of Slab
RC	ESST2	5	338	48" x 24"	7	48" x 7"						Slab Bars on End of Slab
RC	ESCV1	5	338	48" x 24"	7	18" x 8" x 5"						Hook (Bars) on sidewalk
RC	ESCV2	5	338	48" x 24"	7	18" x 8" x 5"						Bars on sidewalk
RC	ESCV3	5	338	48" x 24"	7	18" x 8" x 5"						Bars Top of Slab
RC	ESCV4	5	338	48" x 24"	7	18" x 8" x 5"						Bars End of Slab
SPAN 3 (E)												
RC	ESST1	5	338	48" x 24"	7	48" x 7"						Hooked Bars in Top of Slab
RC	ESST2	5	338	48" x 24"	7	48" x 7"						Slab Bars on End of Slab
RC	ESCV1	5	338	48" x 24"	7	18" x 8" x 5"						Hook (Bars) on sidewalk
RC	ESCV2	5	338	48" x 24"	7	18" x 8" x 5"						Bars on sidewalk
RC	ESCV3	5	338	48" x 24"	7	18" x 8" x 5"						Bars Top of Slab
RC	ESCV4	5	338	48" x 24"	7	18" x 8" x 5"						Bars End of Slab
SPAN 5												
RC	ESST1	5	338	48" x 24"	7	48" x 7"						Hooked Bars in Top of Slab
RC	ESST2	5	338	48" x 24"	7	48" x 7"						Slab Bars on End of Slab
RC	ESCV1	5	338	48" x 24"	7	18" x 8" x 5"						Hook (Bars) on sidewalk
RC	ESCV2	5	338	48" x 24"	7	18" x 8" x 5"						Bars on sidewalk
RC	ESCV3	5	338	48" x 24"	7	18" x 8" x 5"						Bars Top of Slab
RC	ESCV4	5	338	48" x 24"	7	18" x 8" x 5"						Bars End of Slab
SPAN 7												
RC	ESST1	5	338	48" x 24"	7	48" x 7"						Hooked Bars in Top of Slab
RC	ESST2	5	338	48" x 24"	7	48" x 7"						Slab Bars on End of Slab
RC	ESCV1	5	338	48" x 24"	7	18" x 8" x 5"						Hook (Bars) on sidewalk
RC	ESCV2	5	338	48" x 24"	7	18" x 8" x 5"						Bars on sidewalk
RC	ESCV3	5	338	48" x 24"	7	18" x 8" x 5"						Bars Top of Slab
RC	ESCV4	5	338	48" x 24"	7	18" x 8" x 5"						Bars End of Slab
SPAN 9												
RC	ESST1	5	338	48" x 24"	7	48" x 7"						Hooked Bars in Top of Slab
RC	ESST2	5	338	48" x 24"	7	48" x 7"						Slab Bars on End of Slab
RC	ESCV1	5	338	48" x 24"	7	18" x 8" x 5"						Hook (Bars) on sidewalk
RC	ESCV2	5	338	48" x 24"	7	18" x 8" x 5"						Bars on sidewalk
RC	ESCV3	5	338	48" x 24"	7	18" x 8" x 5"						Bars Top of Slab
RC	ESCV4	5	338	48" x 24"	7	18" x 8" x 5"						Bars End of Slab
APPROXIMATE SLAB (S) REQUIRED												
RC	ESST1	5	338	48" x 24"	7	48" x 7"						Bars on End of Approach
RC	ESST2	5	338	48" x 24"	7	48" x 7"						Bars Top of Slab
RC	ESCV1	5	338	48" x 24"	7	18" x 8" x 5"						Bars on End of Approach
RC	ESCV2	5	338	48" x 24"	7	18" x 8" x 5"						Bars on End of Approach
RC	ESCV3	5	338	48" x 24"	7	18" x 8" x 5"						Bars on End of Approach
RC	ESCV4	5	338	48" x 24"	7	18" x 8" x 5"						Bars on End of Approach

MARK	SHE. NO.	LENGTH	TYPE	A	B	C	D	E	F	G	LOCATION	
SPAN 1 (EAST)												
RC	ESST1	5	338	48" x 24"	7	48" x 7"						Hooked Bars in Top of Slab
RC	ESST2	5	338	48" x 24"	7	48" x 7"						Slab Bars on End of Slab
RC	ESCV1	5	338	48" x 24"	7	18" x 8" x 5"						Hook (Bars) on sidewalk
RC	ESCV2	5	338	48" x 24"	7	18" x 8" x 5"						Bars on sidewalk
RC	ESCV3	5	338	48" x 24"	7	18" x 8" x 5"						Bars Top of Slab
RC	ESCV4	5	338	48" x 24"	7	18" x 8" x 5"						Bars End of Slab
SPAN 3 (E)												
RC	ESST1	5	338	48" x 24"	7	48" x 7"						Hooked Bars in Top of Slab
RC	ESST2	5	338	48" x 24"	7	48" x 7"						Slab Bars on End of Slab
RC	ESCV1	5	338	48" x 24"	7	18" x 8" x 5"						Hook (Bars) on sidewalk
RC	ESCV2	5	338	48" x 24"	7	18" x 8" x 5"						Bars on sidewalk
RC	ESCV3	5	338	48" x 24"	7	18" x 8" x 5"						Bars Top of Slab
RC	ESCV4	5	338	48" x 24"	7	18" x 8" x 5"						Bars End of Slab
SPAN 5												
RC	ESST1	5	338	48" x 24"	7	48" x 7"						Hooked Bars in Top of Slab
RC	ESST2	5	338	48" x 24"	7	48" x 7"						Slab Bars on End of Slab
RC	ESCV1	5	338	48" x 24"	7	18" x 8" x 5"						Hook (Bars) on sidewalk
RC	ESCV2	5	338	48" x 24"	7	18" x 8" x 5"						Bars on sidewalk
RC	ESCV3	5	338	48" x 24"	7	18" x 8" x 5"						Bars Top of Slab
RC	ESCV4	5	338	48" x 24"	7	18" x 8" x 5"						Bars End of Slab
SPAN 7												
RC	ESST1	5	338	48" x 24"	7	48" x 7"						Hooked Bars in Top of Slab
RC	ESST2	5	338	48" x 24"	7	48" x 7"						Slab Bars on End of Slab
RC	ESCV1	5	338	48" x 24"	7	18" x 8" x 5"						Hook (Bars) on sidewalk
RC	ESCV2	5	338	48" x 24"	7	18" x 8" x 5"						Bars on sidewalk
RC	ESCV3	5	338	48" x 24"	7	18" x 8" x 5"						Bars Top of Slab
RC	ESCV4	5	338	48" x 24"	7	18" x 8" x 5"						Bars End of Slab
SPAN 9												
RC	ESST1	5	338	48" x 24"	7	48" x 7"						Hooked Bars in Top of Slab
RC	ESST2	5	338	48" x 24"	7	48" x 7"						Slab Bars on End of Slab
RC	ESCV1	5	338	48" x 24"	7	18" x 8" x 5"						Hook (Bars) on sidewalk
RC	ESCV2	5	338	48" x 24"	7	18" x 8" x 5"						Bars on sidewalk
RC	ESCV3	5	338	48" x 24"	7	18" x 8" x 5"						Bars Top of Slab
RC	ESCV4	5	338	48" x 24"	7	18" x 8" x 5"						Bars End of Slab



ALL DIMENSIONS ARE OUT TO OUT OF BARS

APPROVED

[Signature]
 Design Chief Engineer (11/2/12)

SR. NO. 3
 SOUTHERN TIRE EXPRESSWAY
 OVER I-95/SARASOTA R.L.R.
 EASTBOUND S WESTBOUND
 SUPERSTRUCTURE SLAB
 BAR LIST

DRAWING NO. **G7-4**

PROJECT ENGINEER *[Signature]*
 DESIGN CHECKED BY *[Signature]*
 DRAWN BY *[Signature]*
 F.A.S.T.E. G7-4

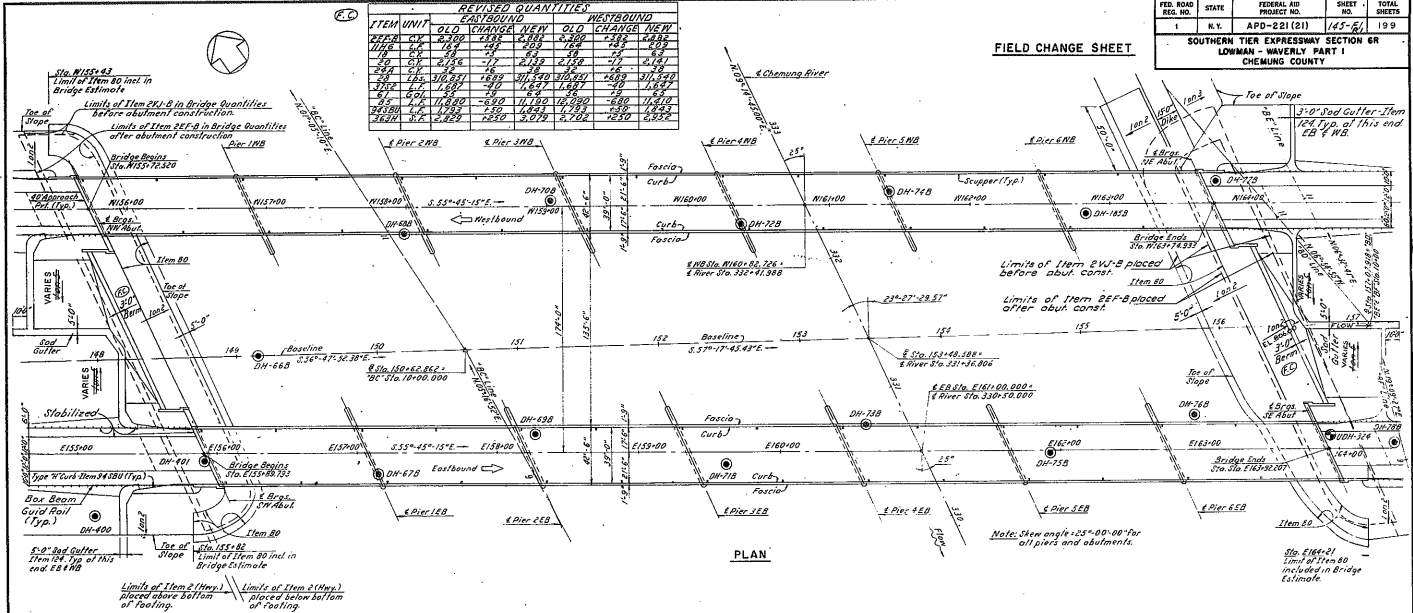
Note: RC indicates Field Change in the size.

FIELD CHANGE SHEET

FED. ROAD DIST. NO.	STATE	FEDERAL AID PROJECT NO.	SHEET NO.	TOTAL SHEETS
1	N.Y.	APD-221(21)	145-B	199
SOUTHERN TIER EXPRESSWAY SECTION 6R LOWMAN - WAVERLY PART I CHEMUNG COUNTY				

ITEM	UNIT	REVISED QUANTITIES	
		CONTRACT	CHANGED
222A	cu yd	1,880	1,880
222B	cu yd	1,880	1,880
222C	cu yd	1,880	1,880
222D	cu yd	1,880	1,880
222E	cu yd	1,880	1,880
222F	cu yd	1,880	1,880
222G	cu yd	1,880	1,880
222H	cu yd	1,880	1,880
222I	cu yd	1,880	1,880
222J	cu yd	1,880	1,880
222K	cu yd	1,880	1,880
222L	cu yd	1,880	1,880
222M	cu yd	1,880	1,880
222N	cu yd	1,880	1,880
222O	cu yd	1,880	1,880
222P	cu yd	1,880	1,880
222Q	cu yd	1,880	1,880
222R	cu yd	1,880	1,880
222S	cu yd	1,880	1,880
222T	cu yd	1,880	1,880
222U	cu yd	1,880	1,880
222V	cu yd	1,880	1,880
222W	cu yd	1,880	1,880
222X	cu yd	1,880	1,880
222Y	cu yd	1,880	1,880
222Z	cu yd	1,880	1,880

FIELD CHANGE SHEET



ELEVATION

REVISIONS

- 1. For General Notes, see Dwg. No. S-3.
- 2. For Location Plan, see Dwg. No. S-1.
- 3. For Layout Plan, see Dwg. No. S-2.
- 4. For Payment Details of Abutments, see Dwg. No. 3.

By	Date	Check
Checked by: <i>[Signature]</i>		
Checked by: <i>[Signature]</i>		
Checked by: <i>[Signature]</i>		

Proposed and recommended
[Signature]
 Consulting Engineers

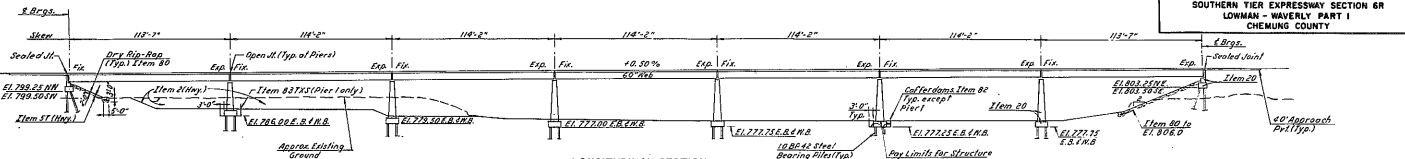
DATE: 1 of 16
 SCALE: 1"=30'
 SHEET: 145-B

GOODING & ODEA
 CONSULTING ENGINEERS



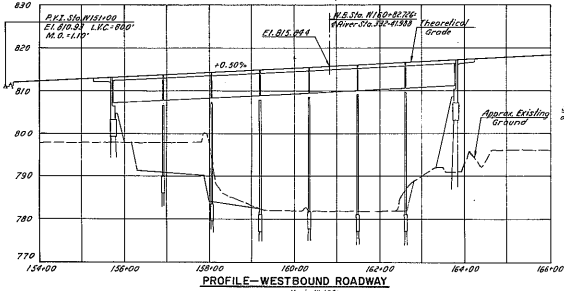
FED. ROAD DIST. NO.	STATE	FEDERAL AID PROJECT NO.	SHEET NO.	TOTAL SHEETS
1	N.Y.	APD-221(21)	146	200

SOUTHERN TIER EXPRESSWAY SECTION 6R
LOWMAN - WAVERLY PART I
CHEMUNG COUNTY



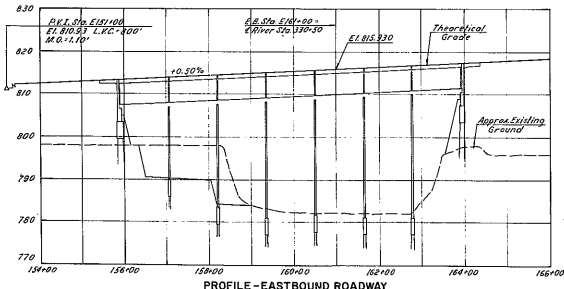
LONGITUDINAL SECTION (ALONG EASTBOUND)

Scale: 1" = 30'



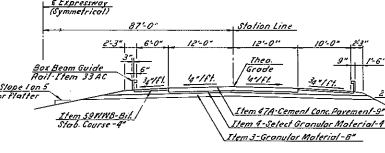
PROFILE - WESTBOUND ROADWAY

Scale: Horiz. 1" = 100' Vert. 1" = 10'



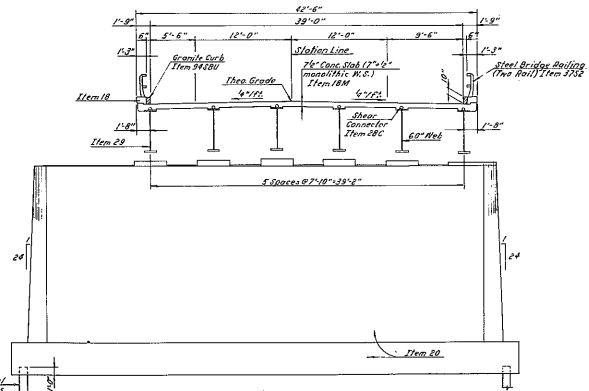
PROFILE - EASTBOUND ROADWAY

Scale: Horiz. 1" = 100' Vert. 1" = 10'



APPROACH SECTION - EXPRESSWAY (IN DIRECTION OF TRAVEL)

Scale: 3" = 1'-0"



TYPICAL SECTION (IN DIRECTION OF TRAVEL)

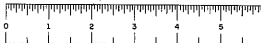
Scale: 3" = 1'-0"

In Charge	By	Checked
Checked by: <i>[Signature]</i>		
Design Checked by: <i>[Signature]</i>		
Revised by: <i>[Signature]</i>		
Revised Checked by: <i>[Signature]</i>		

Prepared and recommended by: *[Signature]*
GOODEDIP & O'DEA
Consulting Engineers

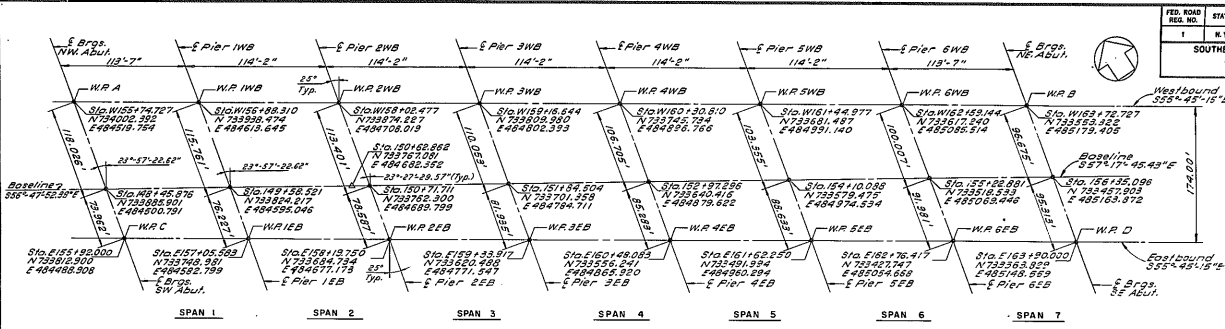
BRIDGE NO. 3
EXPRESSWAY OVER CHEMUNG RIVER
SECTIONS AND PROFILES

DWG. NO.	SCALE	DATE	GOODKIND & O'DEA CONSULTING ENGINEERS
2 of 16	A1	1/17/17	

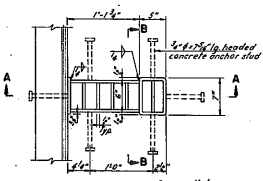


FED. ROAD DIST. NO.	STATE	FEDERAL AID PROJECT NO.	SHEET NO.	TOTAL SHEETS
1	N.Y.	APD-221(13)	117	260

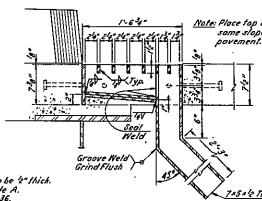
SOUTHERN TIER EXPRESSWAY SECTION 6R
LOWMAN - WAVERLY PART I
CHEMUNG COUNTY



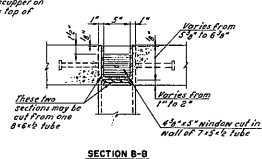
LAYOUT PLAN
No Scale



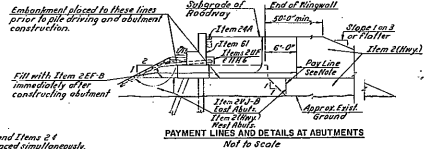
PLAN



SECTION A-A



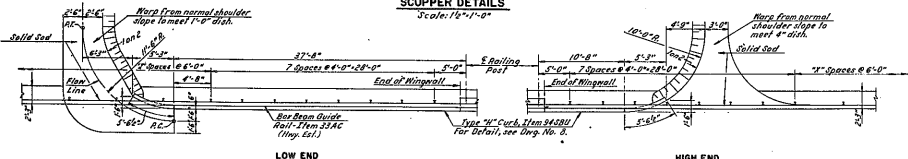
SECTION B-B



PAYMENT LINES AND DETAILS AT ABUTMENTS
Not to Scale

Scupper Notes:
 1. Fabricate in scuppers to be 5" thick.
 2. Tubes - A.S.T.M. A240, Grade A.
 3. Anchor Studs - A.S.T.M. A108, Grade 1015 or 1020. Scuppers shall be fabricated in accordance with MB after fabrication is complete.
 4. Scuppers shall be paid for under Item 25.
 5. For location of scuppers, see Dwg. No. 1 and 13.

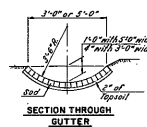
SCUPPER DETAILS
Scale: 1/4"=1'-0"



LOW END

HIGH END

DRAINAGE DETAILS AT ENDS OF BRIDGE
Scale: 1/4"=1'-0"



SECTION THROUGH GUTTER

By	Date	Checked
Designed by <i>C. G. Baller</i>		
Drawn by <i>L. J. Baller</i>		
Checked by <i>L. J. Baller</i>		
Head Checked by <i>L. J. Baller</i>		

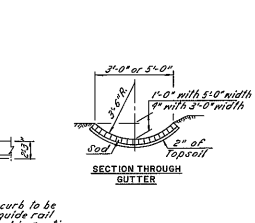
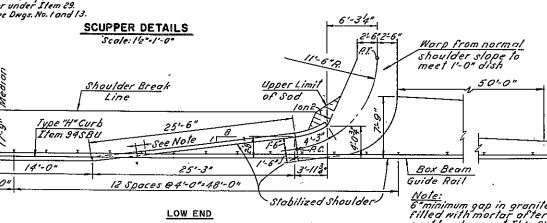
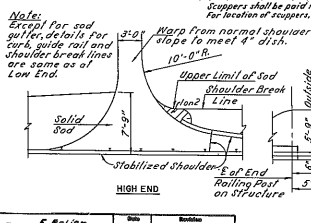
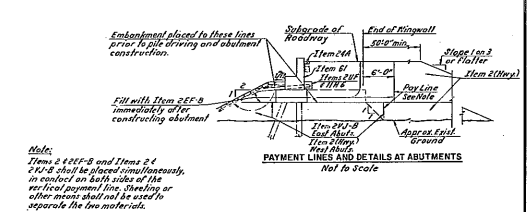
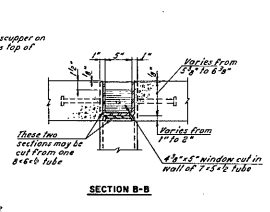
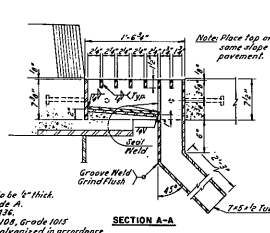
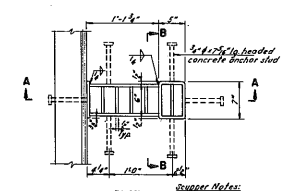
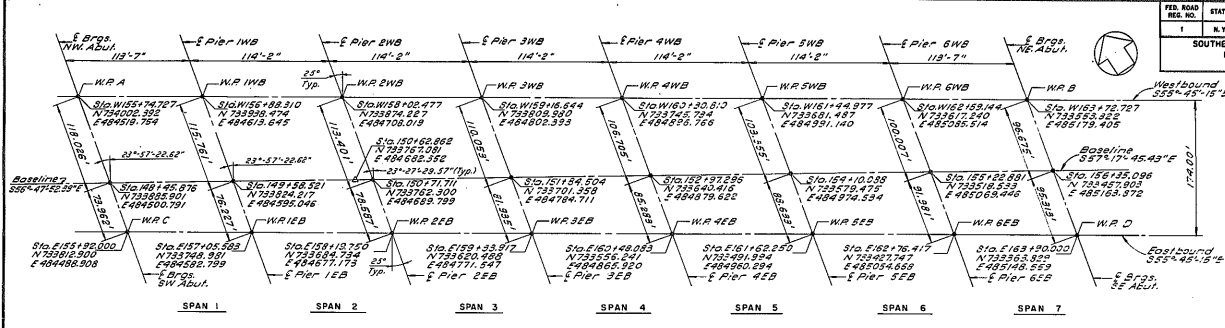
Prepared and recommended by *A. J. V. Baller*
 COOKING & O'DEA
 Consulting Engineers

BRIDGE NO. 3
 EXPRESSWAY OVER CHEMUNG RIVER
 LAYOUT PLAN & DRAINAGE DETAILS
 DWG. NO. 3 OF 16
 SCALE 1/4"=1'-0"
 DATE 5/20/49
 COOKING & O'DEA
 CONSULTING ENGINEERS

FED. ROAD DIST. NO.	STATE	FEDERAL AID PROJECT NO.	SHEET NO.	TOTAL SHEETS
1	N.Y.	APD-310113	147-77	200

SOUTHERN TIER EXPRESSWAY SECTION 6R
LOWMAN - WAVERLY PART I
CHEMUNG COUNTY

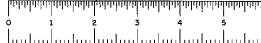
FIELD CHANGE SHEET



APPROVED
11/1/1957

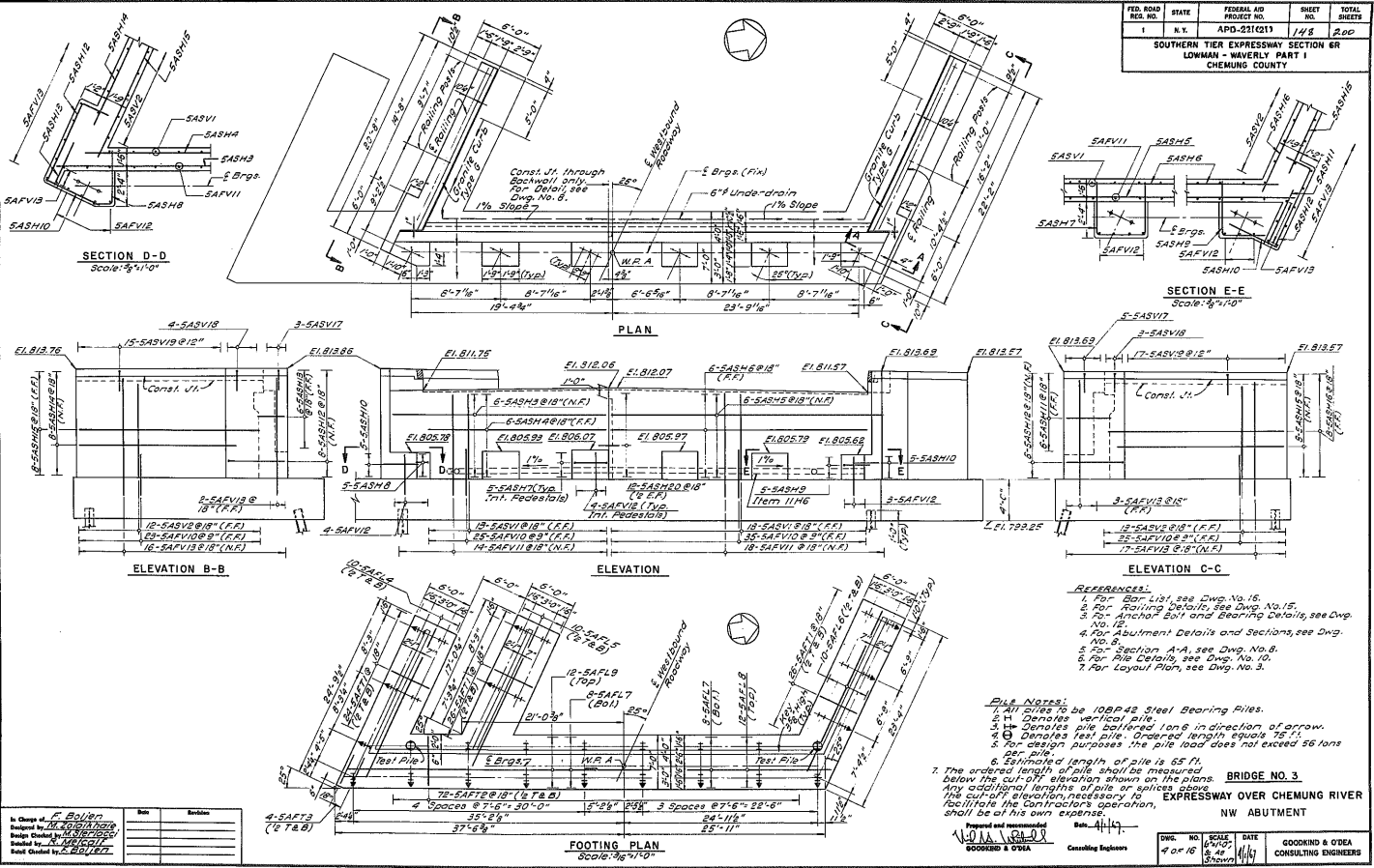
BRIDGE NO. 3
EXPRESSWAY OVER CHEMUNG RIVER
LAYOUT PLAN & DRAINAGE DETAILS

DWG. NO.	SCALE	DATE	GOODING & ODEA CONSULTING ENGINEERS
3-07-16	AS SHOWN	11/1/57	



FED. ROAD DIST. NO.	STATE	FEDERAL AID PROJECT NO.	SHEET NO.	TOTAL SHEETS
1	N.Y.	APD-221(21)	148	200

SOUTHERN TIER EXPRESSWAY SECTION 6R
LOWWAY - WAVERLY PART I
CHEMUNG COUNTY



- REFERENCES:**
1. For Bar List, see Dwg. No. 15.
 2. For Rolling Details, see Dwg. No. 15.
 3. For Anchor Bolt and Bearing Details, see Dwg. No. 12.
 4. For Abutment Details and Sections, see Dwg. No. 3.
 5. For Section A-A, see Dwg. No. 8.
 6. For Pile Details, see Dwg. No. 10.
 7. For Layout Plan, see Dwg. No. 3.

- PILE NOTES:**
1. All piles to be 100#48 Steel Bearing Piles.
 2. H denotes vertical pile.
 3. L denotes pile battered long in direction of arrow.
 4. G denotes test pile. Ordered length equals 58'-11".
 5. For design purposes the pile load does not exceed 56 tons per pile.
 6. Estimated length of pile is 65 ft.
 7. The ordered length of pile shall be measured below the cut-off elevation shown on the plans. Any additional length of pile or splices above the cut-off elevation necessary to facilitate the Contractor's operation, shall be at his own expense.

BRIDGE NO. 3

EXPRESSWAY OVER CHEMUNG RIVER
NW ABUTMENT

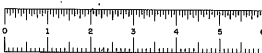
Prepared and recommended
WOODRUFF & O'DEA
Consulting Engineers

Rev. 4/1/47

DWG. NO.	SCALE	DATE	GOODING & O'DEA CONSULTING ENGINEERS
40-16	5/8"	4/1/47	

By	Checked

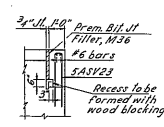
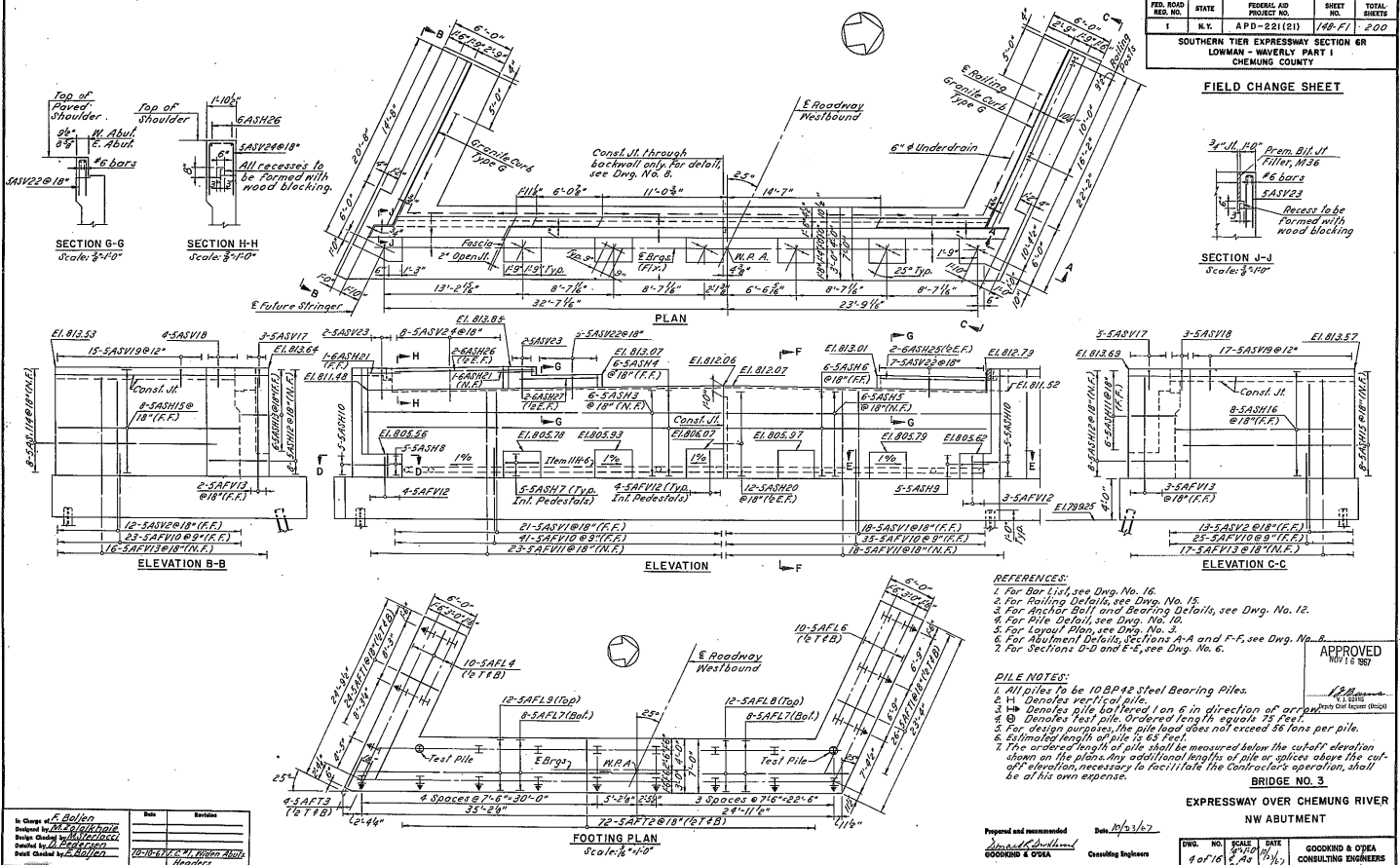
In Charge: C. Bolger
Designed by: H. G. O'Dea
Checked by: J. W. Woodruff
Scale: 1/8" = 1'-0"



FED. ROAD DIST. NO.	STATE	FEDERAL AID PROJECT NO.	SHEET NO.	TOTAL SHEETS
1	N.Y.	APD-221(21)	148-F1	200

SOUTHERN TIER EXPRESSWAY SECTION 6R
LOWMAN - WAVERLY PART I
CHEMUNG COUNTY

FIELD CHANGE SHEET



SECTION J-J Scale: 3/4"=1'-0"

SECTION G-G Scale: 3/4"=1'-0"

SECTION H-H Scale: 3/4"=1'-0"

PLAN

ELEVATION B-B

ELEVATION

ELEVATION C-C

FOOTING PLAN

REFERENCES:

1. For Bar List, see Dwg. No. 16.
2. For Piling Details, see Dwg. No. 15.
3. For Anchor Bolt and Bearing Details, see Dwg. No. 12.
4. For Pile Detail, see Dwg. No. 10.
5. For Layout Plan, see Dwg. No. 3.
6. For Abutment Details, Sections A-A and F-F, see Dwg. No. 4.
7. For Sections D-D and E-E, see Dwg. No. 6.

PILE NOTES:

1. All piles to be 10 BP #2 steel bearing piles.
2. In denotes vertical pile.
3. In denotes pile battered 1 on 6 in direction of approach.
4. In denotes test pile. Ordered length equals 75 feet.
5. For design purposes, the pile load does not exceed 56 tons per pile.
6. Estimated length of pile is 65 feet.
7. The ordered length of pile shall be measured below the cut-off elevation shown on the plans. Any additional length of pile or splices above the cut-off elevation, necessary to facilitate the Contractor's operation, shall be at his own expense.

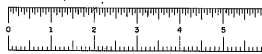
APPROVED
Nov 16 1967

BRIDGE NO. 3
EXPRESSWAY OVER CHEMUNG RIVER
NW ABUTMENT

Prepared and recommended by: *[Signature]*
Checked by: *[Signature]*
Consulting Engineers

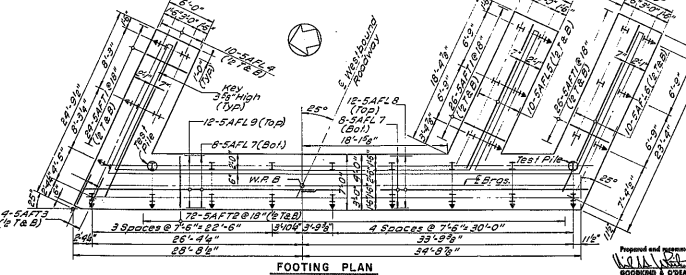
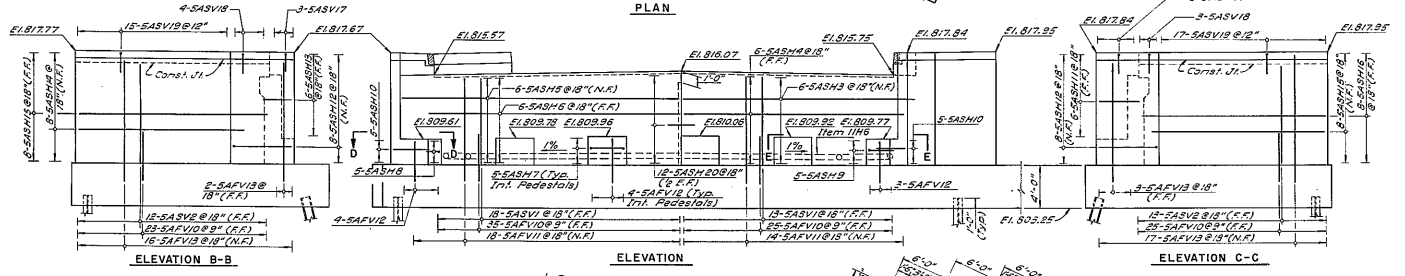
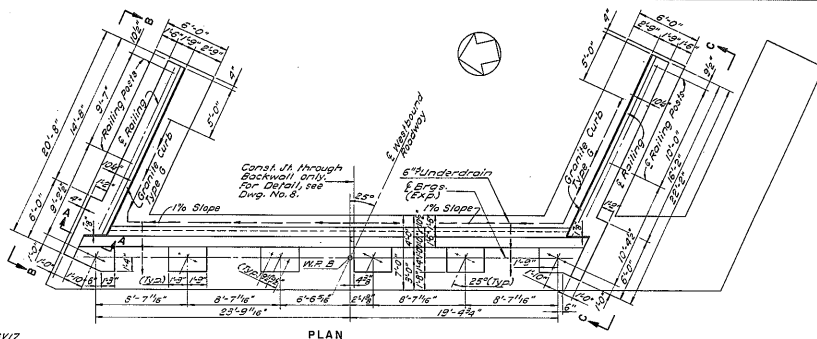
DWG. NO.	SCALE	DATE	BY
4 of 16	3/4"=1'-0"	10/27/67	Goodkind & O'Pea

In Charge of Design	Date	Revised
<i>[Signature]</i>		



FED. ROAD DIST. NO.	STATE	FEDERAL AID PROJECT NO.	SHEET NO.	TOTAL SHEETS
1	N.Y.	APD-221(21)	149	200

SOUTHERN TIER EXPRESSWAY SECTION 6R
LOWMAN - WAVERLY PART 1
CHEMUNG COUNTY



- REFERENCES:**
- For Bar List, see Dwg. No. 16.
 - For Reinforcing Details, see Dwg. No. 15.
 - For Anchor Bolt and Bearing Details, see Dwg. No. 12.
 - For Abutment Details and Sections, see Dwg. No. 8.
 - For Section A-A, see Dwg. No. 8.
 - For Pier Details, see Dwg. No. 10.
 - For Sections D-D and E-E, see Dwg. No. 4.
 - For Layout Plan, see Dwg. No. 3.
- PILE NOTES:**
- All piles to be 100#A22 Steel Bearing Piles.
 - Denotes vertical pile.
 - Denotes pile battered 1 on 5 in direction of arrow.
 - Denotes test pile. Ordered length equals 30 ft.
 - For design purposes the pile load does not exceed 28 tons per pile.
 - Estimated length of pile is 70 ft.
 - The ordered length of pile shall be measured below the cut-off elevation shown on the plans. Any additional lengths of pile or splices above the cut-off elevation necessary to BRIDGE NO. 3 facilitate the Contractor's operation, shall be of his own expense.

In Charge	Date	Revision
C. Quinn		
Checked by: J. J. ...		
Design Checked by: ...		
Scale Checked by: ...		

Prepared and approved by: *[Signature]*
Consulting Engineers

Date: 4/1/47

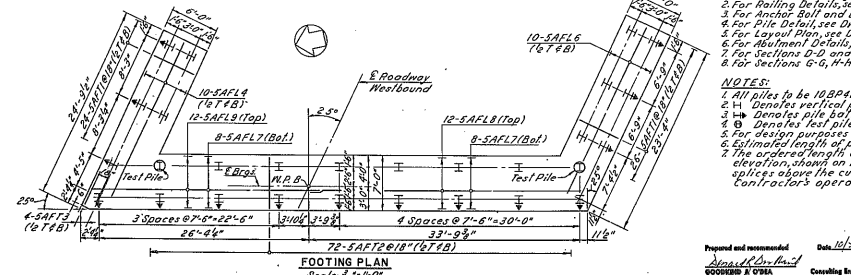
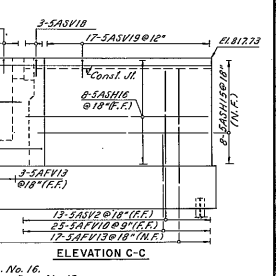
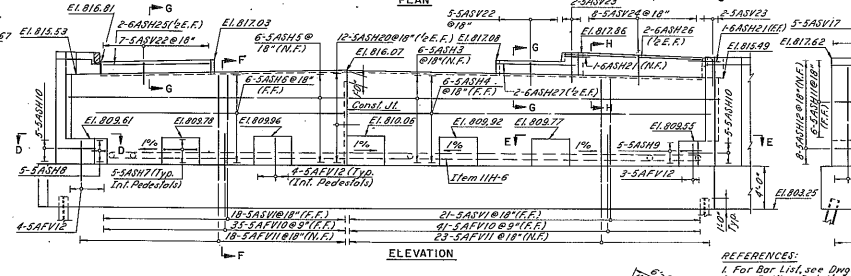
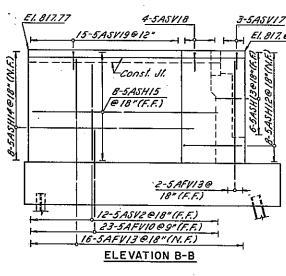
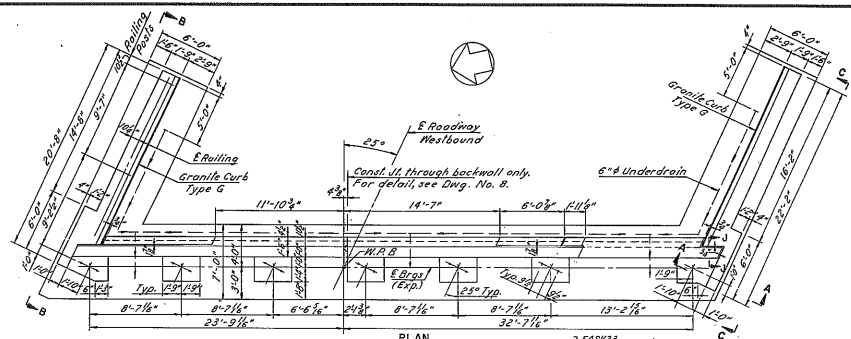
DWG. NO.	SCALE	DATE	GOODING & O'DEA CONSULTING ENGINEERS
50-18	1/4" = 1'-0"	4/1/47	



FED. ROAD DIST. NO.	STATE	FEDERAL AID PROJECT NO.	SHEET NO.	TOTAL SHEETS
1	N.Y.	APD-22(21)	145-F	200

SOUTHERN TIER EXPRESSWAY SECTION 6R
LOWMAN - WAVERLY PART
CHEMUNG COUNTY

FIELD CHANGE SHEET



- REFERENCES:**
1. For Bar List, see Dwg. No. 16.
 2. For Railing Details, see Dwg. No. 15.
 3. For Anchor Bolt and Bearing Details, see Dwg. No. 12.
 4. For Pile Details, see Dwg. No. 13.
 5. For Layout Plan, see Dwg. No. 3.
 6. For Abutment Details, Sections A-A and E-E, see Dwg. No. 4.
 7. For Sections D-D and E-E, see Dwg. No. 6.
 8. For Sections G-G, H-H and J-J, see Dwg. No. 4.
- NOTES:**
1. All piles to be 10 BPA2 steel Bearing Piles.
 2. Φ Denotes vertical pile.
 3. \ominus Denotes pile battered for on ϕ in direction of arrow.
 4. \oplus Denotes test pile. Graded length equals 60 feet.
 5. For design purposes the pile load does not exceed 36 tons per pile.
 6. Estimated length of pile is 70 feet.
 7. The ordered length of pile shall be measured below the cut-off elevation, shown on the plans. Any additional lengths of pile or splices above the cut-off elevation, necessary to facilitate the contractor's operation, shall be of his own expense.

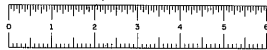
APPROVED
11/11/67
V.L. Smith
District Engineer (Bridge)

By	Date	Revised
Designed by E. Ballinger		
Checked by J. J. Conroy		
Drawn by J. J. Conroy		
Field Checked by E. Ballinger		

Prepared and recommended by
WOODWARD & CURRIE
Consulting Engineers
Date: 10/23/67

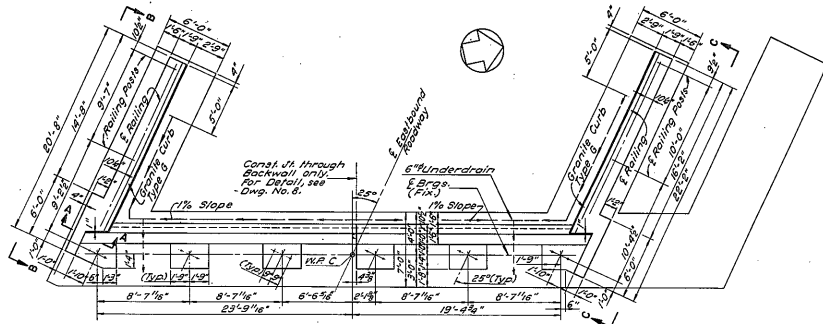
BRIDGE NO. 3
EXPRESSWAY OVER CHEMUNG RIVER
NE ABUTMENT

DATE	SCALE	DATE	SCALE	WOODWARD & CURRIE CONSULTING ENGINEERS
3/1/66	1/8" = 1'-0"	10/23/67	1/8" = 1'-0"	

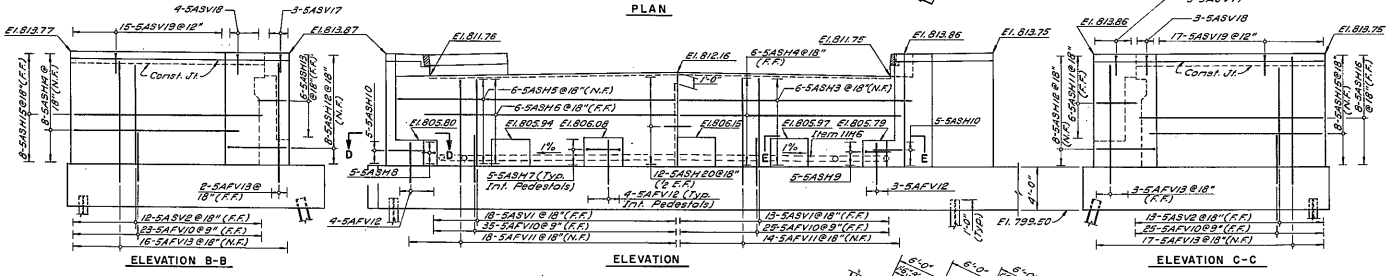


FED. ROAD DIST. NO.	STATE	FEDERAL AID PROJECT NO.	SHEET NO.	TOTAL SHEETS
1	N.Y.	APP-221(21)	150	200

SOUTHERN TIER EXPRESSWAY SECTION 6R
LOWMAN - WARELY PART I
CHEMUNG COUNTY



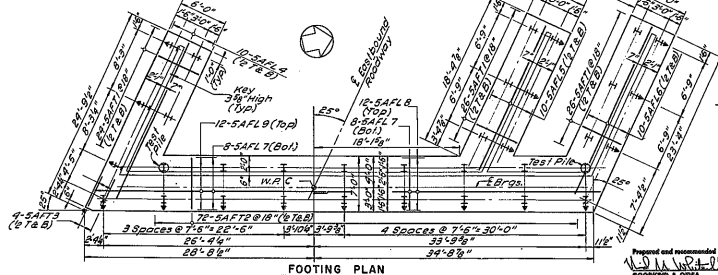
PLAN



ELEVATION B-B

ELEVATION

ELEVATION C-C



FOOTING PLAN

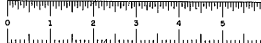
- REFERENCES:**
- For Bar List, see Dwg. No. 16.
 - For Rebar Details, see Dwg. No. 15.
 - For Anchor Bolt and Bearing Details, see Dwg. No. 8.
 - For Abutment Details and Sections, see Dwg. No. 6.
 - For Section A-A, see Dwg. No. 6.
 - For Pile Details, see Dwg. No. 10.
 - For Sections D-D and E-E, see Dwg. No. 4.
 - For Layout Plan, see Dwg. No. 3.
- PILE NOTES:**
- All piles to be 10B48 Steel Bearing Piles.
 1. Denotes vertical pile.
 2. Denotes pile battered 1 on 6 in direction of arrow.
 3. Concrete test pile. Order of length equal 75 ft.
 - For design purposes the pile load does not exceed 25 tons per pile.
 - Estimated length of pile is 65 ft.
 - The ordered length of pile shall be measured below the cut-off elevation shown on the plans. Any additional lengths of pile or splices above the cut-off elevation, necessary to facilitate the Contractor's operation, shall be at his own expense.

In Charge of C. G. O'DEA	Date	Revised
Designed by W. J. O'DEA		
Checked by C. G. O'DEA		
Drawn by C. G. O'DEA		

Prepared and recommended by
WOODS & O'DEA
Consulting Engineers

Rev. 4/1/49
Consulting Engineers

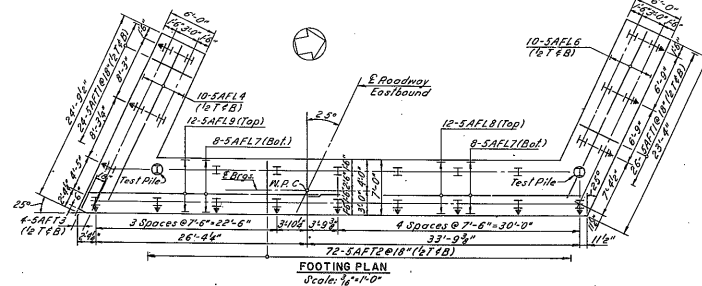
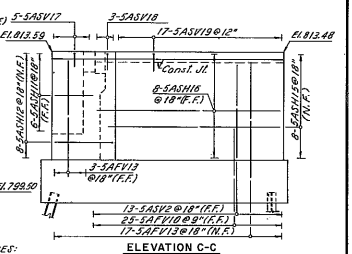
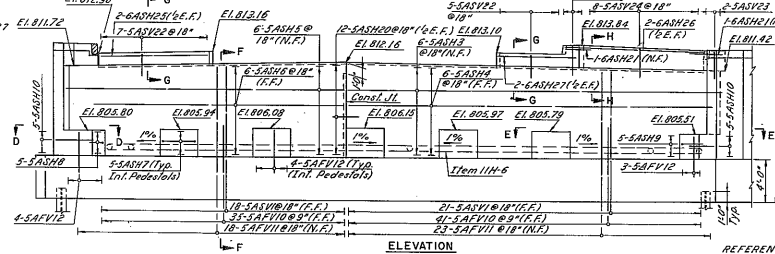
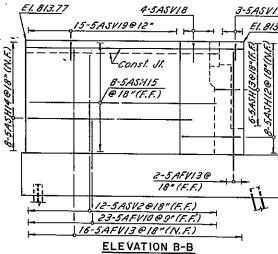
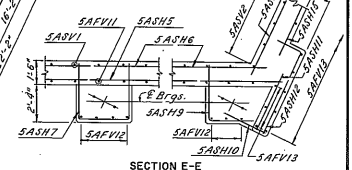
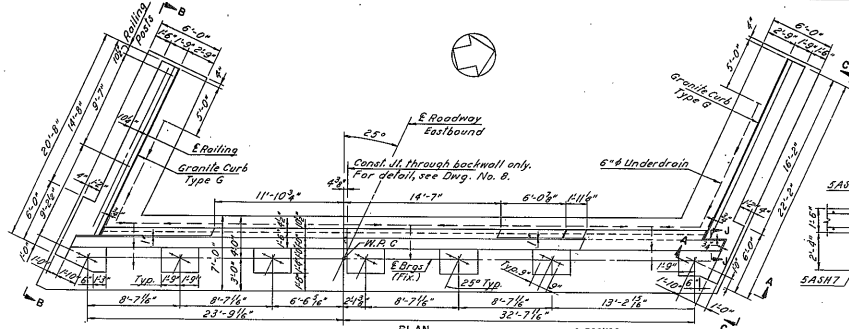
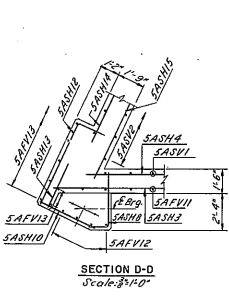
DWG. NO.	SCALE	DATE	GOODWIN & O'DEA CONSULTING ENGINEERS
6 OF 15	1/4" = 1'-0"	4/1/49	



FED. ROAD DIST. NO.	STATE	FEDERAL AID PROJECT NO.	SHEET NO.	TOTAL SHEETS
1	N.Y.	APD-221(21)	150-F1	200

SOUTHERN TIER EXPRESSWAY SECTION 6R
LOWMAN - WAVERLY PART I
CHEMUNG COUNTY

FIELD CHANGE SHEET



REFERENCES:

1. For Bar List, see Dwg. No. 16.
2. For Railings Details, see Dwg. No. 15.
3. For Anchor Bolt and Bearing Details, see Dwg. No. 12.
4. For Pile Detail, see Dwg. No. 10.
5. For Lay-out Plan, see Dwg. No. 2.
6. For Abutment Details, Sections A-A and F-F, see Dwg. No. 1.
7. For Sections G-G, H-H and J-J, see Dwg. No. 4.

NOTES:

1. All piles to be 10B940 Steel Bearing Piles.
2. H denotes vertical pile.
3. W denotes pile battered 1 on 6 in direction of travel.
4. B denotes test pile. Ordered length equals 75 feet.
5. For design purposes the pile load shall not exceed 56 tons per pile.
6. Estimated length of pile is 42 feet.
7. The ordered length of pile shall be measured below the cut-off elevation, shown on the plans. Any additional length of pile or splices above the cut-off elevation, necessary to facilitate the Contractor's operation, shall be at his own expense.

BRIDGE NO. 3

EXPRESSWAY OVER CHEMUNG RIVER
SW ABUTMENT

Prepared and recommended by: *[Signature]*
Checked by: *[Signature]*
Goodrich & O'Dea Consulting Engineers

Date: 10/23/67
Drawing Engineer

SHEET NO.	SCALE	DATE	GOODRICH & O'DEA CONSULTING ENGINEERS
6 of 16	1/4"	10/23/67	

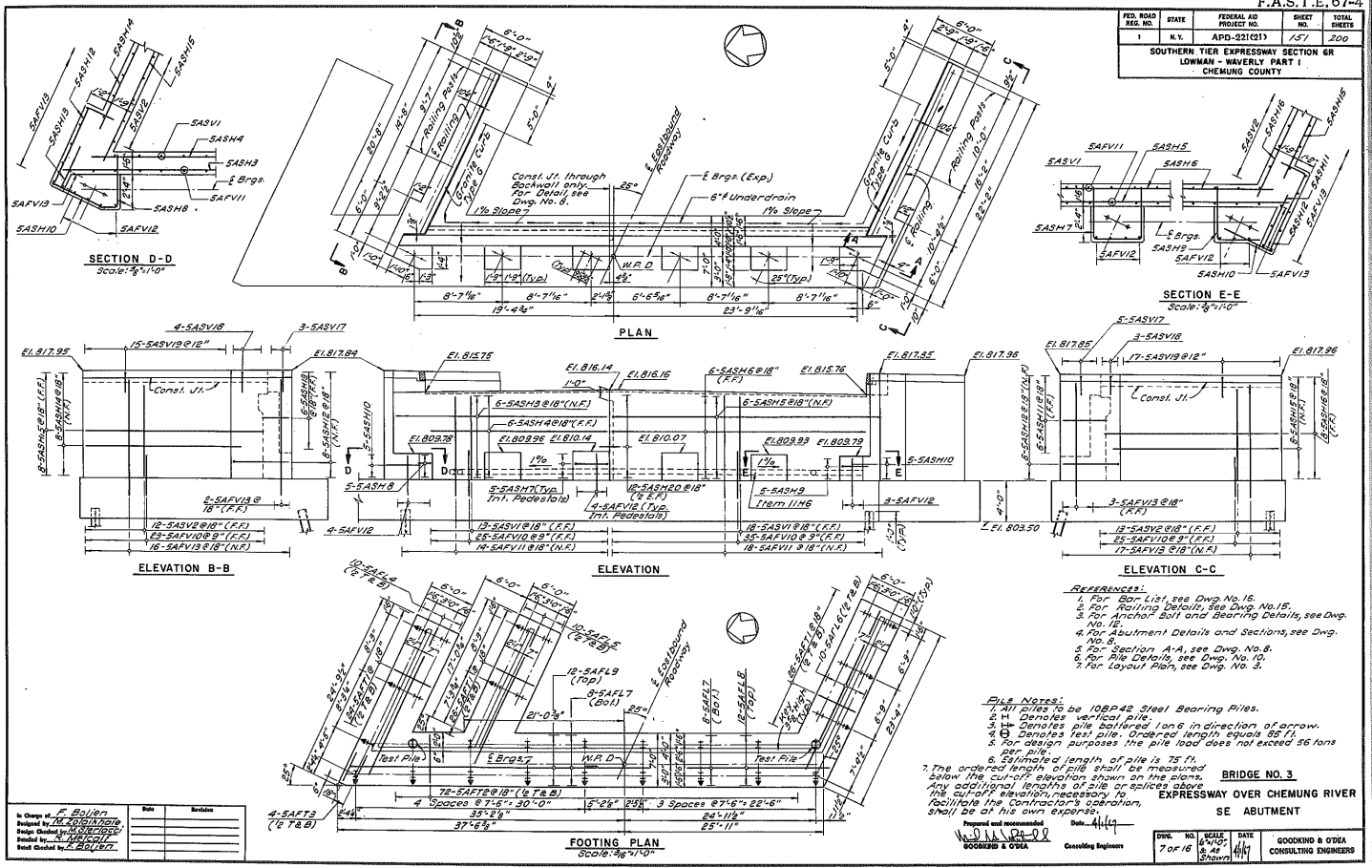
In Charge of: *[Signature]*
Designed by: *[Signature]*
Detail Checked by: *[Signature]*
Field Checked by: *[Signature]*

Date	Revisions



FED. ROAD DIST. NO.	STATE	FEDERAL AID PROJECT NO.	SHEET NO.	TOTAL SHEETS
1	N.Y.	APD-221(21)	157	200

SOUTHERN TIER EXPRESSWAY SECTION 6R
LOWMAN - WAVERLY PART I
CHEMUNG COUNTY



- REFERENCES:**
1. For Bar List, see Dwg. No. 16.
 2. For Railing Details, see Dwg. No. 15.
 3. For Anchor Bolt and Bearing Details, see Dwg. No. 15.
 4. For Abutment Details and Sections, see Dwg. No. 8.
 5. For Section A-A, see Dwg. No. 8.
 6. For Pile Details, see Dwg. No. 10.
 7. For Layout Plan, see Dwg. No. 3.

- PILE NOTES:**
1. All piles to be 105P42 Steel Bearing Piles.
 2. \uparrow Denotes vertical pile.
 3. \rightarrow Denotes pile battered 1 on 6 in direction of arrow.
 4. \ominus Denotes test pile. Ordered length equals 85 ft.
 5. For design purposes the pile load does not exceed 56 tons per pile.
 6. Estimated length of pile shall be measured below the cut-off elevation shown on the plans. Any additional lengths of piles or splices above the cut-off elevation, necessary to facilitate the contractor's operation, shall be at his own expense.

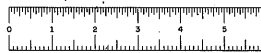
BRIDGE NO. 3
EXPRESSWAY OVER CHEMUNG RIVER
SE ABUTMENT

In Charge of	Drawn	Checked
<i>E. Bolten</i>		
Designed by		
Field Checked by		
Head Checked by		

Prepared and recommended by
W. J. O'Dea
Consulting Engineer

DATE	SCALE	DATE	DATE
7/2/16	1/4" = 1'-0"	4/11/17	4/11/17

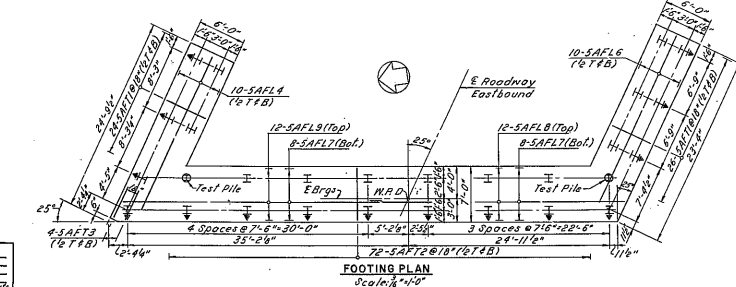
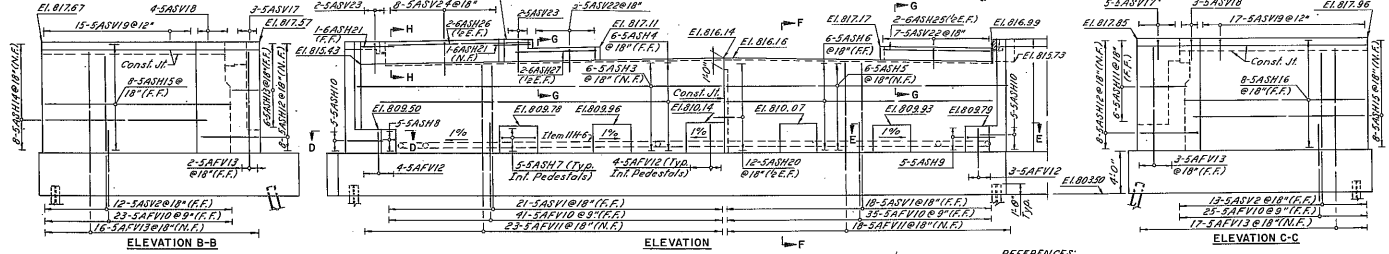
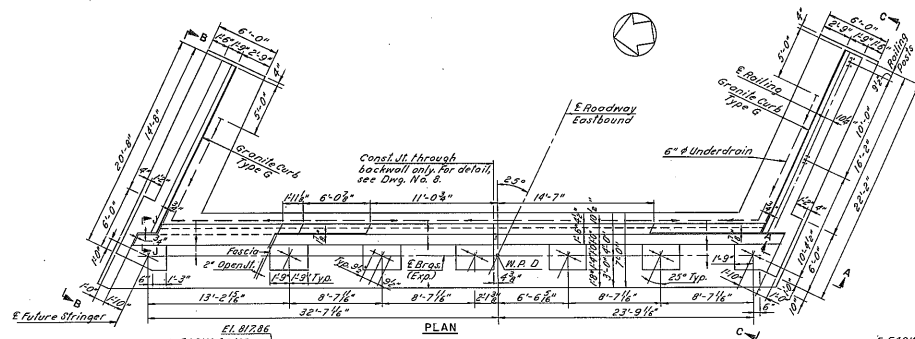
GODKIND & O'DEA
CONSULTING ENGINEERS



FED. ROAD DIST. NO.	STATE	FEDERAL AID PROJECT NO.	SHEET NO.	TOTAL SHEETS
1	N.Y.	APD-22(21)	151-F	200

SOUTHERN TIER EXPRESSWAY SECTION 6R
 LOWMAN - WAVERLY PART I
 CHEMUNG COUNTY

FIELD CHANGE SHEET



REFERENCES:
 1. For Bar List, see Dwg. No. 16.
 2. For Piling Details, see Dwg. No. 15.
 3. For Section Bolt and Bearing Details, see Dwg. No. 12.
 4. For Pile Detail, see Dwg. No. 10.
 5. For Layout Plan, see Dwg. No. 3.
 6. For Abutment Details, Sections A and F-F, see Dwg. No. 10.
 7. For Sections D-D and E-E, see Dwg. No. 6.
 8. For Sections G-G, H-H and J-J, see Dwg. No. 4.

PILE NOTES:
 1. All piles to be 10 DP42 Steel Bearing Piles.
 2. Denotes ver. pile.
 3. Denotes pile battered 1 on 6 in direction of arrow.
 4. Denotes test pile. Order of length given as test.
 5. For design purposes, the pile load does not exceed 56 tons per pile.
 6. Estimated length of pile is 72 feet.
 7. The ordered length of pile shall be measured below the subgrade elevation shown on the plans. Any additional lengths of pile or splices above the cut-off elevation, necessary to facilitate the contractor's operation, shall be of his own expense.

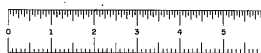
APPROVED
 NOV 18 1967
 S. S. GORING
 State Civil Engineer

In Charge	E. Bolton	Scale	1/4" = 1'-0"
Designed by	A. E. R. [illegible]	Checked by	[illegible]
Drawn by	[illegible]	Field Checked by	[illegible]
Field Checked by	[illegible]		

Prepared and recommended
 Date 10/23/67
 Consulting Engineer

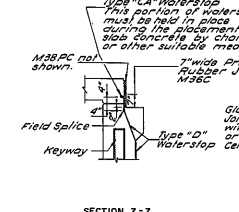
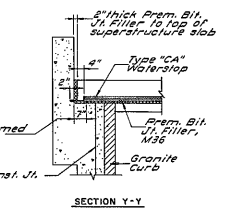
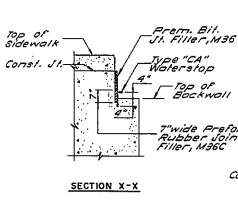
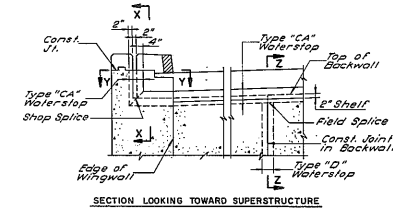
BRIDGE NO. 3
 EXPRESSWAY OVER CHEMUNG RIVER
 SE ABUTMENT

DWG. NO.	SCALE	DATE	GOODING & O'NEAL CONSULTING ENGINEERS
7 of 16	1/4" = 1'-0"	10/23/67	

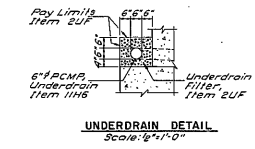
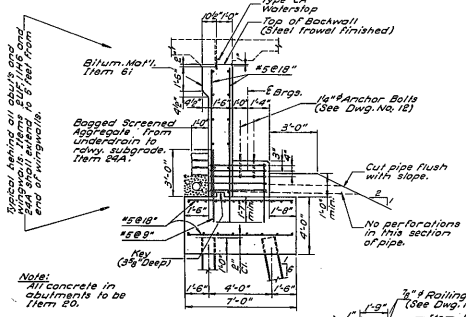


FED. ROAD DIST. NO.	STATE	FEDERAL AID PROJECT NO.	SHEET NO.	TOTAL SHEETS
1	N.Y.	APD-221(G)1	152	200

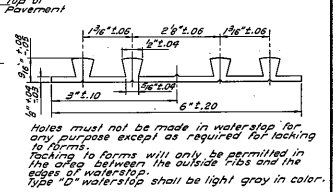
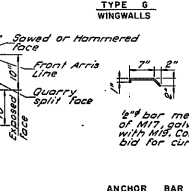
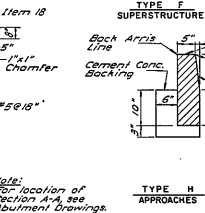
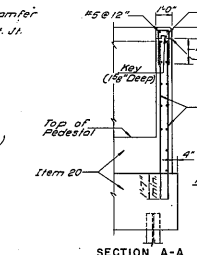
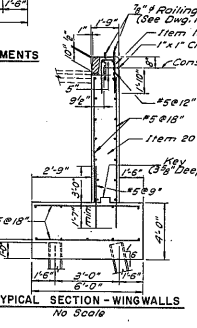
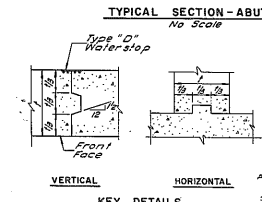
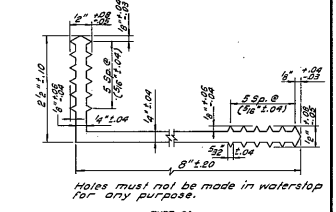
SOUTHERN TIER EXPRESSWAY SECTION 6R
LORHAM - WAVERLY, PART I
CHEMUNG COUNTY



INSTALLATION OF WATERSTOPS
No Scale



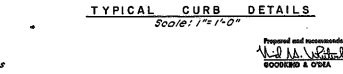
Note:
All splices shall be thermal splices. Method for field splicing shall be approved by Deputy Chief Engineer. Exposed waterstop must be protected from damage by suitable means during all phases of construction.



in Charge of C. Bolter
Designed by C. Bolter
Checked by C. Bolter
Revised by C. Bolter
Final Check by C. Bolter

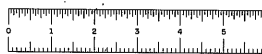
Date	Revisions

Note:
All reinforcement in abutment and wingwall sections to be #5 bars unless otherwise noted.



BRIDGE NO. 3
EXPRESSWAY OVER CHEMUNG RIVER
ABUTMENT DETAILS

DATE	SCALE	SHEET	ENGINEER
8 or 10	AS SHOWN	44/4	GOODKIND & ODEA CONSULTING ENGINEERS



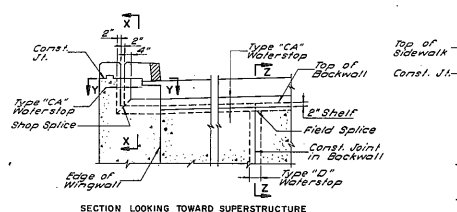
FED. ROAD DIST. NO.	STATE	FEDERAL AID PROJECT NO.	SHEET NO.	TOTAL SHEETS
1	N.Y.	APD-221(213)	152(F)	200

SOUTHERN TIER EXPRESSWAY SECTION 6R

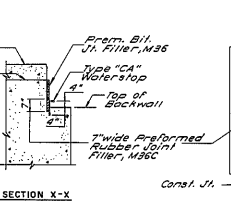
LOWMAN - WARELY, PART I

CHEMUNG COUNTY

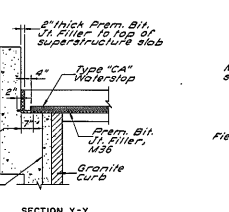
FIELD CHANGE SHEET



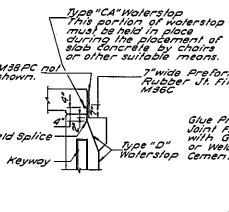
SECTION LOOKING TOWARD SUPERSTRUCTURE



SECTION X-X



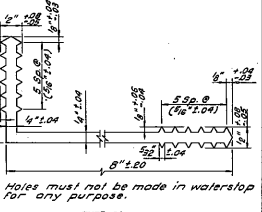
SECTION Y-Y



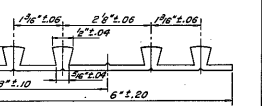
SECTION Z-Z

INSTALLATION OF WATERSTOPS

No Scale

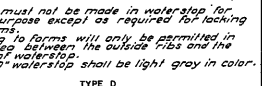


TYPE CA



TYPE F SUPERSTRUCTURE

TYPE G WINGWALLS



TYPE D

PVC WATERSTOPS (M38T)

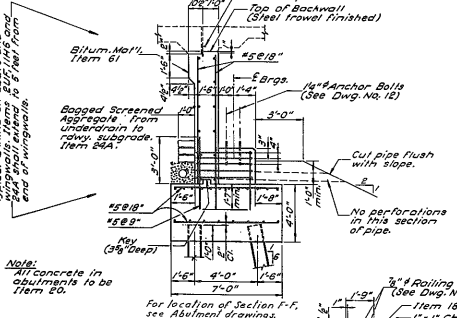
Scale: Full Size



BRIDGE NO. 3

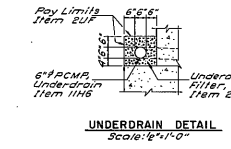
EXPRESSWAY OVER CHEMUNG RIVER

ABUTMENT DETAILS



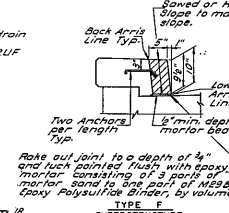
SECTION F-F

No Scale



UNDERDRAIN DETAIL

Scale: 1/4\"/>

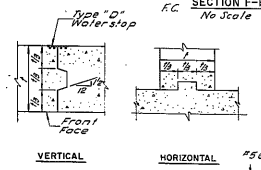


TYPE H APPROACHES

ANCHOR BAR

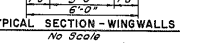
TYPICAL CURB DETAILS

Scale: 1/4\"/>



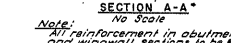
KEY DETAILS

No Scale



TYPICAL SECTION - WINGWALLS

No Scale



SECTION A-A

No Scale

Note: All reinforcement in abutment and wingwall sections to be #5 bars unless otherwise noted.

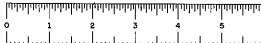
in Charge of Design	By	Checked
Checked by	By	Checked
Design Checked by	By	Checked

Prepared and recommended by: [Signature]

Checked by: [Signature]

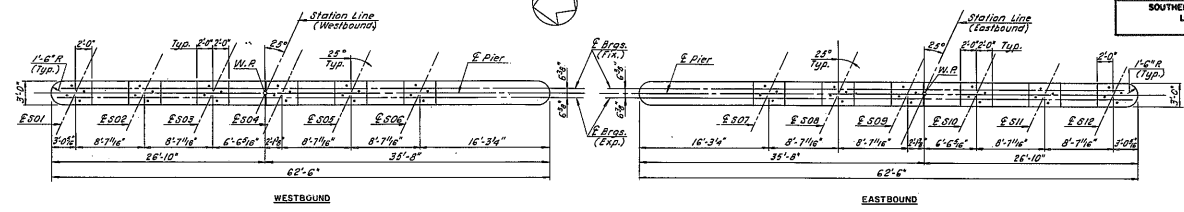
DATE	SCALE	NO.	ENGINEER
11/67	AS	8 or 18	GOODENO & O'NEAL

GOODENO & O'NEAL CONSULTING ENGINEERS

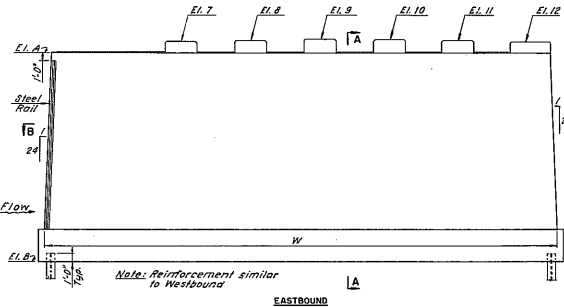
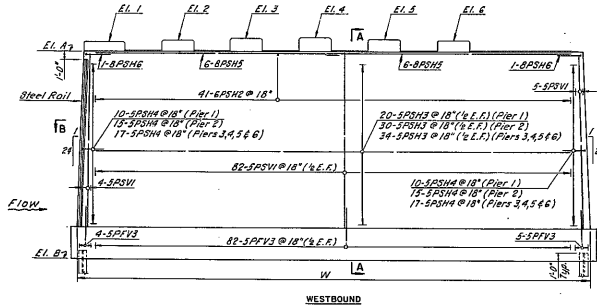


FED. ROAD DIST. NO.	STATE	FEDERAL AID PROJECT NO.	SHEET NO.	TOTAL SHEETS
1	N.Y.	APD-221(C1)	153	200

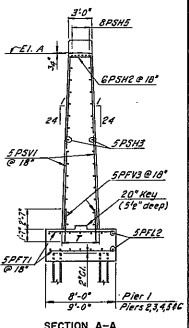
SOUTHERN TIER EXPRESSWAY SECTION ON LOWMAN - WAVERLY PART I CHEMUNG COUNTY



PLAN



LONGITUDINAL SECTION



SECTION A-A

PIER NO.	PAD ELEVATIONS					EL. A	EL. B	T	W
	1	2	3	4	5				
1WB	806.18	806.33	806.53	806.49	806.35	803.00	786.00	2'-3"	63'-9"
2WB	806.73	806.91	807.11	807.21	807.06	805.50	779.30	4'-10"	64'-4"
3WB	807.25	807.49	807.68	807.76	807.63	807.49	806.00	5'-11"	64'-7"
4WB	807.83	808.01	808.23	808.33	808.20	808.06	806.71	5'-11"	64'-7"
5WB	808.47	808.61	808.86	808.98	808.77	808.63	807.25	5'-8"	64'-8"
6WB	808.64	808.81	808.99	809.49	809.35	809.20	807.75	5'-2"	64'-8"

PIER NO.	PAD ELEVATIONS					EL. A	EL. B	T	W
	7	8	9	10	11				
7EB	806.33	806.33	806.71	806.63	806.50	806.37	803.00	2'-3"	63'-9"
8EB	806.96	807.10	807.24	807.23	807.07	806.94	805.50	4'-10"	64'-4"
9EB	807.49	807.47	807.55	807.79	807.63	807.57	806.00	5'-11"	64'-7"
10EB	808.26	808.24	808.23	808.36	808.22	808.10	806.76	5'-11"	64'-7"
11EB	808.63	808.82	808.90	808.59	808.79	808.63	807.25	5'-8"	64'-8"
12EB	808.67	808.39	808.57	808.50	808.56	808.22	807.75	5'-2"	64'-8"

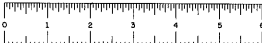
References:
 1. For Bar List see Dwg. No. 16.
 2. For Pier and Pile Details see Dwg. No. 10.
 3. For Layout Plan see Dwg. No. 3.

BRIDGE NO. 3
EXPRESSWAY OVER CHEMUNG RIVER
PIERS

In Charge of **F. Baillon**
 Designed by **M.R. Baillon**
 Bridge Drawing by **M.R. Baillon**
 Checked by **G. MURPHY**
 Draft Checked by **K. BERRY**

Prepared and recommended by **WOOD & ODEA**
 Consulting Engineers

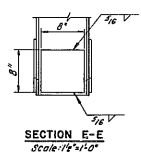
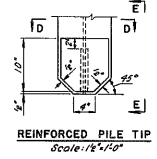
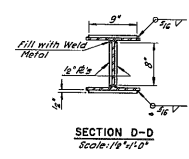
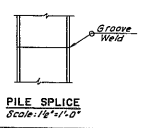
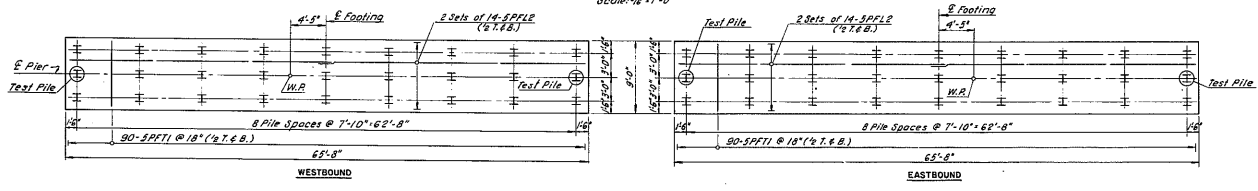
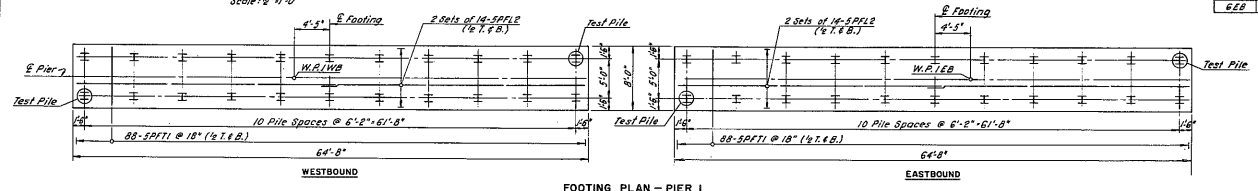
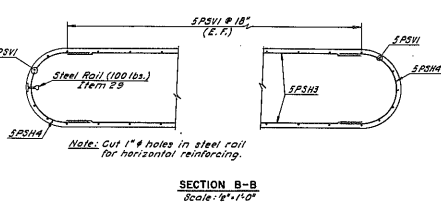
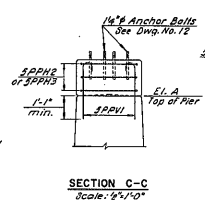
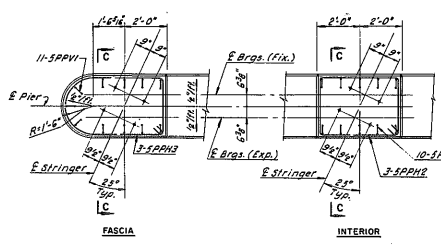
FILE NO.	SCALE	DATE	WOOD & ODEA CONSULTING ENGINEERS
3 of 16	1/4" = 1'-0"	4/14	



FED. ROAD DIST. NO.	STATE	FEDERAL AID - PROJECT NO.	SHEET NO.	TOTAL SHEETS
1	W.V.	APD-271(21)	154	200

SOUTHERN TIER EXPRESSWAY SECTION 6R
LOWMAN - WAVERLY PART I
CHEMUNG COUNTY

PIER NO.	ESTIMATED PILE LENGTH	ORDERED LENGTH TEST PILES
1WB	70'	80'
2WB	60'	70'
3WB	55'	65'
4WB	55'	65'
5WB	45'	50'
6WB	45'	50'
1EB	65'	75'
2EB	55'	65'
3EB	50'	60'
4EB	50'	60'
5EB	45'	50'
6EB	30'	60'



Pile Notes:
 1. All piles to be 10BPA2 Steel Bearing Piles.
 2. For design purposes the pile load does not exceed 26 tons per pile.
 3. The ordered length of pile shall be measured below the cut-off elevations shown on the plans. Any additional length of pile or splices above the cut-off elevation necessary to facilitate the Contractor's operation shall be of his own expense.

References:
 1. For Bar List see Dwg. No. 16.
 2. For location of Section B-B, see Dwg. No. 9.

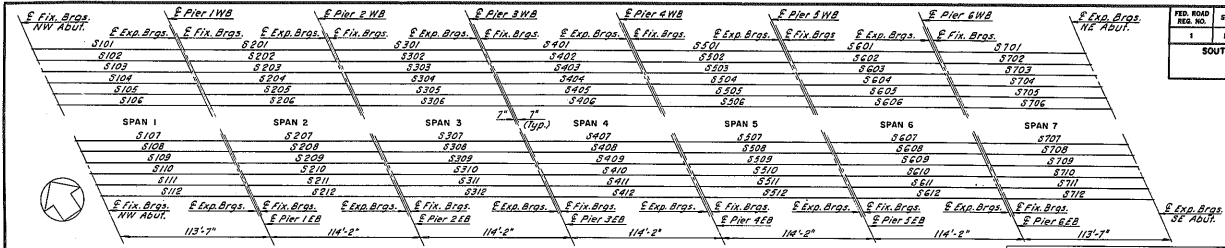
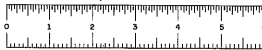
In Charge of Design	By	Checked
Designed by		
Checked by		
Reviewed by		
Final Checked by		

Prepared and recommended
 G. W. M. O'NEAL
 Consulting Engineers

BRIDGE NO. 3
EXPRESSWAY OVER CHEMUNG RIVER

PIER DETAILS

DWG. NO.	SCALE	DATE	GOODING & O'NEAL CONSULTING ENGINEERS
10 of 16	As Shown	4/14	

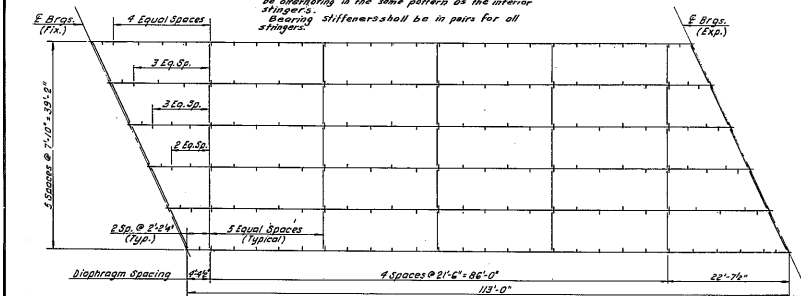


FEED ROAD REG. NO.	STATE	FEDERAL AID PROJECT NO.	SHEET NO.	TOTAL SHEETS
1	N.Y.	APD-221(21)	153	200

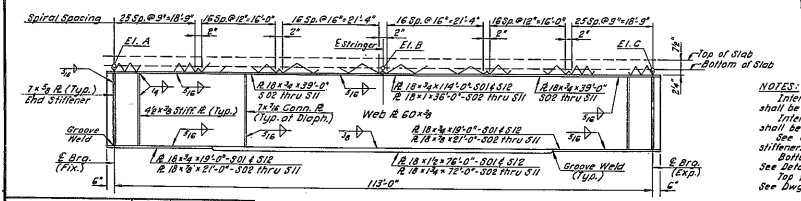
SOUTHERN TIER EXPRESSWAY SECTION 6R
LOWMAN - HAVELLY PART I
CHEMUNG COUNTY

KEY PLAN
NO SCALE

Note: Intermediate stiffeners for wall fascia stringers to be offsetting in the same pattern as the interior stringers.
Bearing stiffeners shall be in pairs for all stringers.



TYPICAL FRAMING PLAN
Scale: 1/4" = 1'-0"



STRINGER ELEVATION
No Scale

CAMBER

STRINGER	STEEL ONLY	TOTAL D.L.
S01/S12	1/4"	3"
S02 Thru S11	3/4"	3 1/8"

Vertical curve camber +0" camber measured along E Stringer.

BOTTOM OF SLAB ELEVATIONS

MARK	A	B	C	MARK	A	B	C
S101	812.10	812.46	812.76	S401	814.07	814.35	814.64
S102	812.26	812.64	812.93	S402	814.23	814.53	814.83
S103	812.55	812.85	813.11	S403	814.43	814.72	815.00
S104	812.64	812.93	813.21	S410	814.37	814.63	814.91
S105	812.50	812.78	813.05	S411	814.22	814.51	814.79
S106	812.35	812.64	812.92	S412	814.08	814.36	814.64
S107	812.36	812.64	812.92	S501	814.46	814.75	815.03
S108	812.14	812.42	812.70	S502	814.24	814.53	814.81
S109	812.72	813.00	813.29	S503	814.25	814.54	814.83
S110	812.66	812.94	813.23	S504	814.93	815.21	815.49
S111	812.51	812.79	813.08	S505	814.78	815.06	815.34
S112	812.37	812.65	812.93	S506	814.64	814.92	815.20
S201	812.15	812.43	812.72	S507	814.64	814.92	815.21
S202	812.93	813.21	813.50	S508	814.22	814.50	814.79
S203	813.11	813.40	813.68	S509	813.00	813.29	813.57
S204	813.21	813.50	813.78	S510	814.94	815.22	815.50
S205	813.07	813.35	813.63	S511	814.02	814.30	814.58
S206	812.93	813.21	813.49	S512	814.62	814.90	815.18
S207	812.93	813.21	813.49	S601	815.03	815.31	815.60
S208	813.11	813.39	813.68	S602	815.22	815.50	815.78
S209	813.29	813.57	813.86	S603	815.40	815.68	815.96
S210	813.29	813.57	813.79	S604	815.20	815.48	815.76
S211	813.08	813.37	813.65	S605	815.25	815.53	815.81
S212	812.94	813.22	813.50	S606	815.21	815.49	815.77
S301	813.32	813.60	813.89	S607	815.21	815.50	815.78
S302	813.50	813.78	814.07	S608	815.29	815.57	815.85
S303	813.68	813.97	814.25	S609	815.29	815.57	815.85
S304	813.79	814.07	814.35	S610	815.21	815.49	815.78
S305	813.64	813.92	814.21	S611	815.21	815.49	815.77
S306	813.50	813.78	814.06	S612	815.20	815.48	815.76
S307	813.20	813.48	813.77	S701	815.60	815.88	816.17
S308	813.08	813.36	813.65	S702	815.78	816.07	816.35
S309	812.96	813.24	813.53	S703	815.97	816.25	816.53
S310	813.80	814.08	814.36	S704	816.07	816.35	816.63
S311	813.65	813.94	814.23	S705	816.21	816.49	816.77
S312	813.51	813.79	814.07	S706	816.18	816.46	816.74
S401	813.89	814.17	814.45	S707	816.28	816.57	816.85
S402	814.07	814.36	814.64	S708	816.36	816.64	816.92
S403	814.22	814.50	814.78	S709	816.15	816.43	816.71
S404	814.36	814.64	814.92	S710	816.08	816.36	816.64
S405	814.21	814.49	814.77	S711	816.24	816.52	816.80
S406	814.07	814.35	814.63	S712	815.79	816.07	816.35

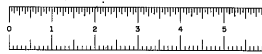
NOTES:
Intermediate stiffeners for interior stringers shall be staggered on each side of the web.
Intermediate stiffeners for fascia stringers shall be placed on the inside face of the web.
See General Notes for methods of connecting stiffeners.
Bottom flanges to be cut to 15" width at bearings. See Detail, Dwg. No. 12.
Top flanges to be cut to clear joint at piers. See Dwg. No. 12.

BRIDGE NO. 3
EXPRESSWAY OVER CHEMUNG RIVER
FRAMING PLAN

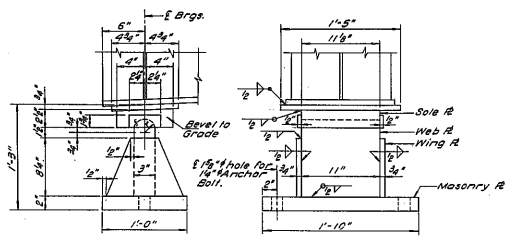
Prepared and recommended by: [Signature]
Checked by: [Signature]
Consulting Engineers

DWG. NO.	SCALE	DATE	GOODING & O'SHA CONSULTING ENGINEERS
11 of 12	As Shown	4/11/47	

In Charge of Design: [Signature]
Checked by: [Signature]
Design Checked by: [Signature]
Fielded by: [Signature]
Detail Checked by: [Signature]

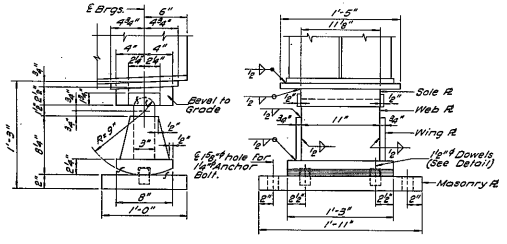


FED. ROAD DIST. NO.	STATE	FEDERAL AID PROJECT NO.	SHEET NO.	TOTAL SHEETS
1	N.Y.	APD-321(21)	156	200
SOUTHERN TIER EXPRESSWAY SECTION 8R LOWHAUSE - HAVERLY PART I CHEMUNG COUNTY				

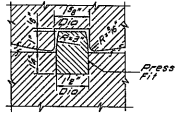


FIXED BEARING
Scale: 2"=1'-0"

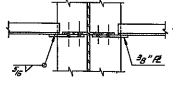
1" = 1/8" for Web R
1" = 1/16" for Sole R



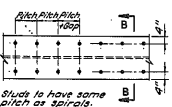
EXPANSION BEARING
Scale: 2"=1'-0"



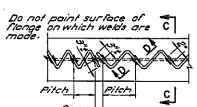
DOWEL DETAIL
Scale: Half Size



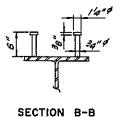
SECTION A-A
Scale: 1"=1'-0"



PARTIAL PLAN OF STUDS
No Scale



PARTIAL PLAN OF SPIRALS
No Scale



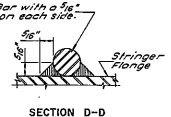
SECTION B-B
No Scale

Studs to have same pitch as spirals.

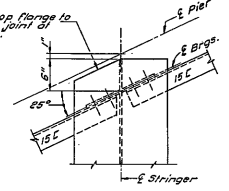
Do not paint surface of flange on which webs are made.

5" Mean Dia.

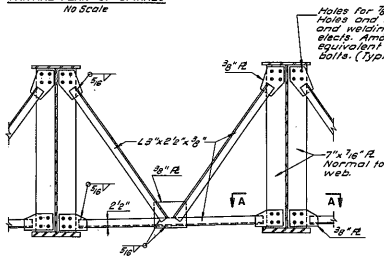
SECTION C-C
No Scale



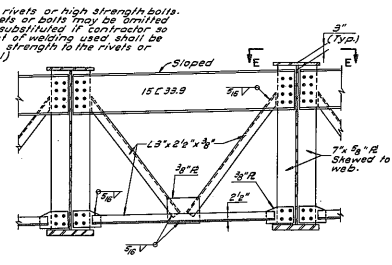
SECTION D-D
Full size



SECTION E-E
Scale: 1/2"=1'-0"

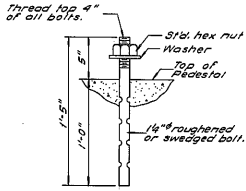


INTERMEDIATE

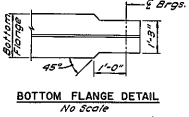


END

DIAPHRAGM DETAILS
No Scale



ANCHOR BOLT DETAIL
No Scale



BOTTOM FLANGE DETAIL
No Scale

Holes for 3/8" rivets or high strength bolts. Holes and rivets or bolts may be drilled and welded substituted if contractor so elects. Amount of welding used shall be equivalent in strength to the rivets or bolts. (Typical)

References: For Framing Plan, see Dwg. No. 11.

By	Checked
Designed by	Reviewed by
Drawn by	Checked by
Scale	Date

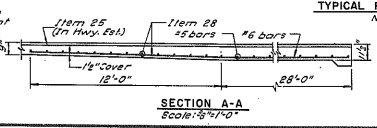
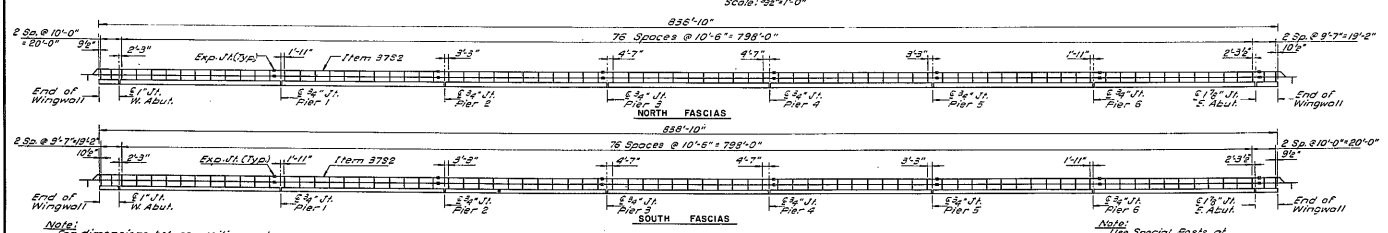
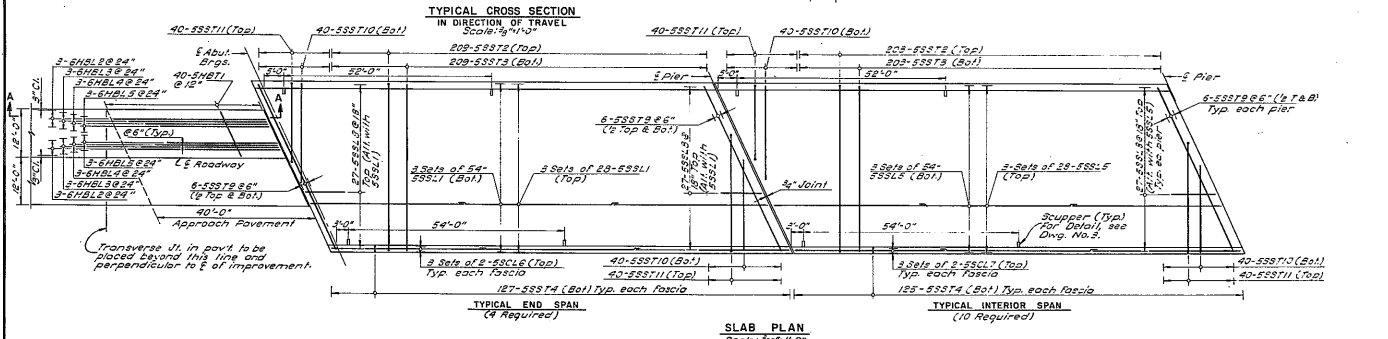
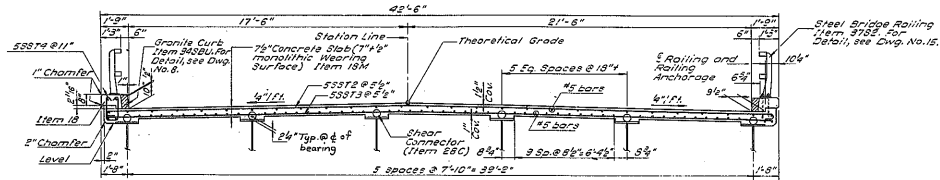
Prepared and recommended by
WOODRUFF & OWEN
Consulting Engineers

BRIDGE NO. 3 EXPRESSWAY OVER CHEMUNG RIVER STEEL DETAILS			
DWG. NO.	SCALE	DATE	BOOKING & ODEA
12 OF 18	AS SHOWN	4/1/49	CONSULTING ENGINEERS



FED. ROAD DIST. NO.	STATE	FEDERAL AID PROJECT NO.	SHEET NO.	TOTAL SHEETS
1	N.Y.	APD-221(21)	137	200

SOUTHERN TIER EXPRESSWAY SECTION ER
LOWMAN - WAVELY PART I
CHEMUNG COUNTY



By	Date	Revised

Prepared and recommended by
W.D. L. 12-08
COOKING & O'NEIL
Consulting Engineers

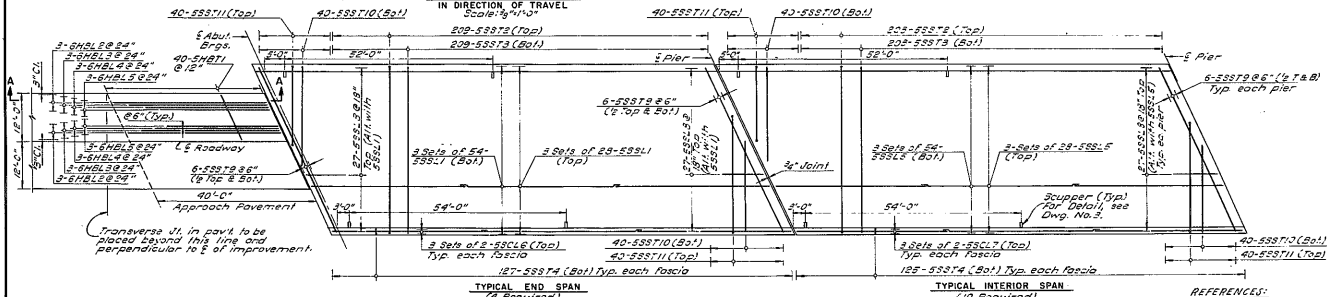
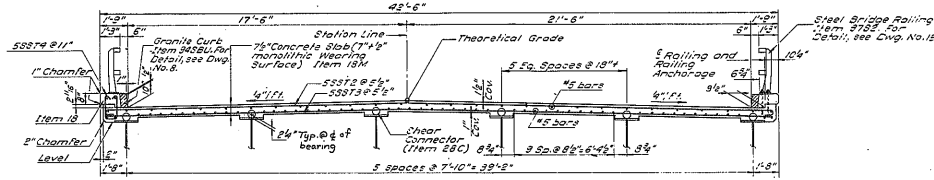
BRIDGE NO. 3
EXPRESSWAY OVER CHEMUNG RIVER
SLAB PLAN AND CROSS SECTION
DWG. NO. 13 OF 16
SCALE AS SHOWN
DATE 11/19
GOODING & O'NEIL
CONSULTING ENGINEERS



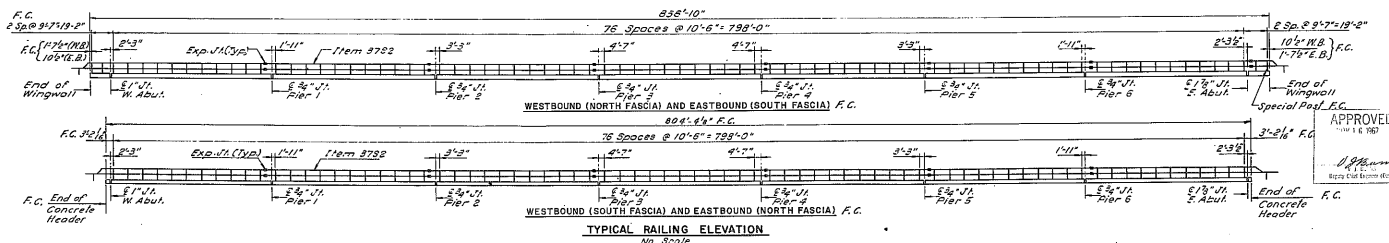
FED. ROAD DIST. NO.	STATE	FEDERAL AID PROJECT NO.	SHEET NO.	TOTAL SHEETS
1	N.Y.	APD-221(21)	157/1	200

SOUTHERN TIER EXPRESSWAY SECTION 6R
LOWMAN - MAVERLY PART 1
CHEMUNG COUNTY

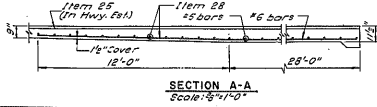
FIELD CHANGE SHEET



REFERENCES:
F.C. For Bar List, see Dwg. No. 16.
For Railing Details, see Dwg. No. 15.



APPROVED
11/16/97
By: [Signature]
Title: [Title]

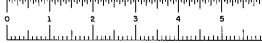


Note:
#6 Bars, Bar Reinforcement for Structures,
is included in the Bridge Quantities. All
other items used in the Reinforced Concrete
Approach Pavement are included in the
Highway Quantities.

Rev.	Revised
1	10-12-97 (F.C. Railing)

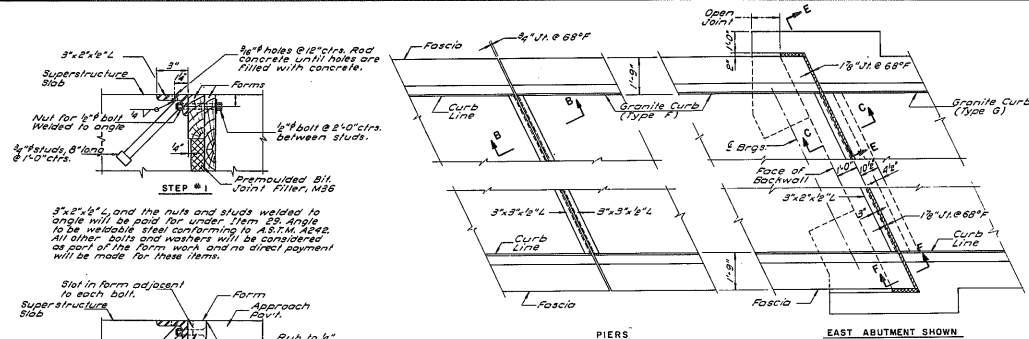
Proposed and recommended
11/16/97
GOODWIN & O'SHA
Consulting Engineers

BRIDGE NO. 3
EXPRESSWAY OVER CHEMUNG RIVER
SLAB PLAN AND CROSS SECTION
DWG. NO. 157 OF 16
SCALE AS SHOWN
DATE 4/1/97
GOODWIN & O'SHA
CONSULTING ENGINEERS

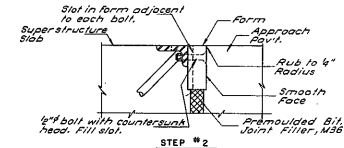


FED. ROAD DIST. NO.	STATE	FEDERAL AID PROJECT NO.	SHEET NO.	TOTAL SHEETS
1	N.Y.	APD-221(13)	1/3	200

SOUTHERN TIER EXPRESSWAY SECTION 67
LOWMAN - WAVERLY PART I
CHEMUNG COUNTY

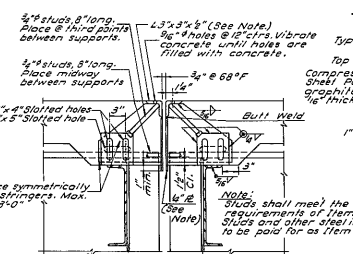


STEP #1
3"x2 1/2"x1/4" L and the nuts and sluds welded to angle will be paid for under Item 25. Angle to be weldable steel conforming to A.S.T.M. A36. All other bolts and washers will be considered as part of the form work and no direct payment will be made for these items.

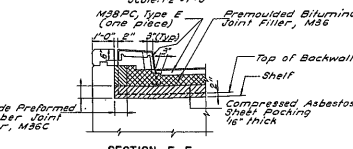


CONSTRUCTION PROCEDURE:
1. Bolt angles to form boards as indicated in Step #1 to proper line and grade.
2. Pour Superstructure Slab.
3. Remove forms and bolts.
4. Place form as indicated in Step #2.
5. Pour approach pavement.
6. Cut off bolt flush with angle with saw saw.
7. Remove form and replace with Preformed Elastic Joint Sealer.

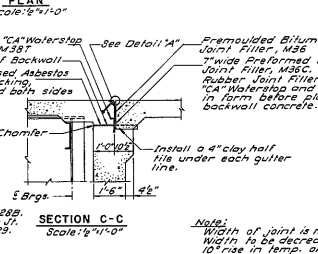
DETAILS OF ARMORING ANGLE AT ABUTMENT
Scale: 3"x1'-0"



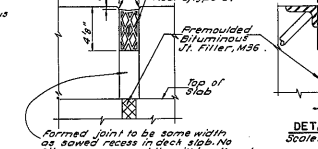
SECTION B-B
Scale: 1/2"x1'-0"
Note: Sluds shall meet the requirements of Item 28B. Sluds and other steel in it to be paid for as Item 29.



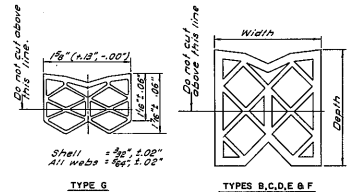
SECTION E-E
Scale: 1/2"x1'-0"



SECTION C-C
Scale: 1/2"x1'-0"



SECTION F-F
No Scale



TYPE G
Shell = 3/8" x 1.02"
All Webs = 3/8" x 1.02"

TYPES B,C,D,E & F

TYPE	DIMENSIONS FOR TYPES B,C,D,E & F	
	WIDTH	DEPTH
B	1/2" x 1.02"	8" x 1.02"
C	1/2" x 1.02"	8" x 1.02"
D	1/2" x 1.02"	8" x 1.02"
E	1/2" x 1.02"	8" x 1.02"
F	1/2" x 1.02"	8" x 1.02"

Any changes in the shape or dimensions of Preformed Elastic Joint Sealer must be approved by the Deputy Chief Engineer. Design. The minimum thickness of any web shall not be less than as specified. The average thickness of all webs shall be within the tolerance specified.

PREFORMED ELASTIC JOINT SEALER - M38PC
No Stock

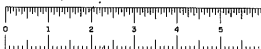
Checked by: E. BOLTON	Date:	Scale:
Designed by: E. BOLTON		
Drawn by: J. BOLTON		
Revised by: J. BOLTON		

REFERENCES:
For Details of Waterstop Installation see Div. No. 8.

BRIDGE NO. 3
EXPRESSWAY OVER CHEMUNG RIVER
JOINT DETAILS

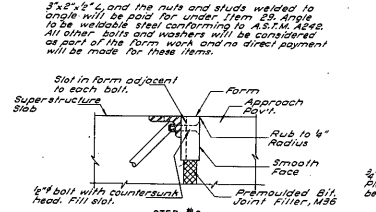
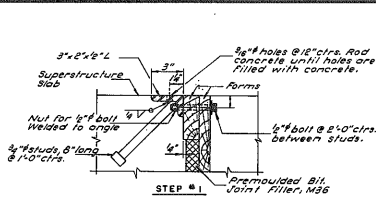
Prepared and recommended by: [Signature]
Checked by: [Signature]
Consulting Engineer

REV.	NO.	DATE	BY	DESCRIPTION
1	1	1/1/67	EB	GOODING & ODEA CONSULTING ENGINEERS



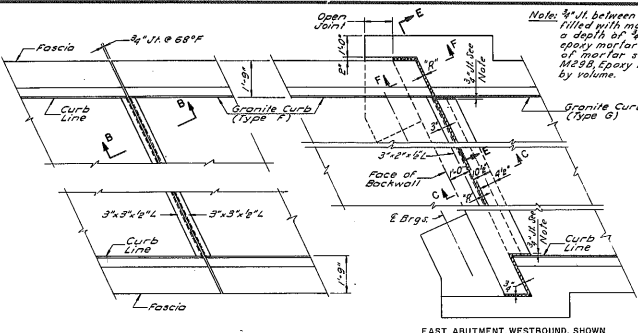
FED. ROAD DIST. NO.	STATE	FEDERAL PROJECT NO.	SHEET NO.	TOTAL SHEETS
1	K.T.	APD-221(01)	138-F	200

SOUTHERN YEAR EXPRESSWAY SECTION OR LOWRIAN - UNIVERSITY PARK - CHENING COUNTY

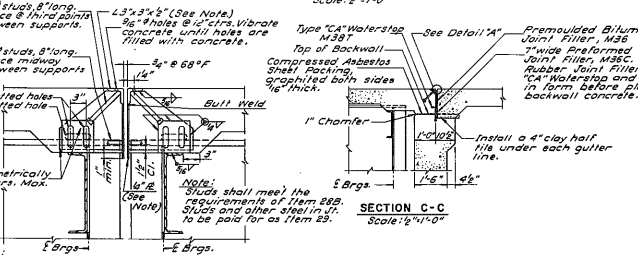


- CONSTRUCTION PROCEDURE:**
1. Bolt angles to form boards as indicated in Step #1 to proper line and grade.
 2. Pour Superstructure Slab.
 3. Remove forms and bolts.
 4. Place form as indicated in Step #2.
 5. Pour Approach Pavement.
 6. Cut off bolt flush with angle with square saw.
 7. Remove form and replace with Preformed Elastic Joint Sealer.

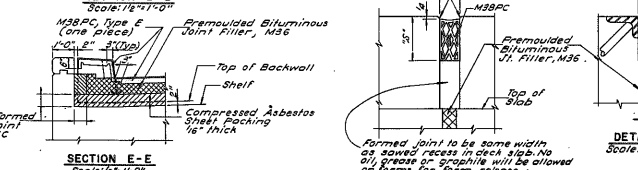
DETAILS OF ARMORING ANGLE AT ABUTMENT
Scale: 3/4"=1'-0"



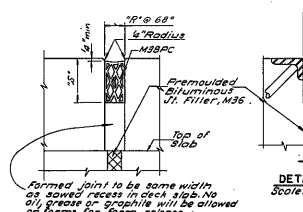
PIERS
Scale: 1/2"=1'-0"



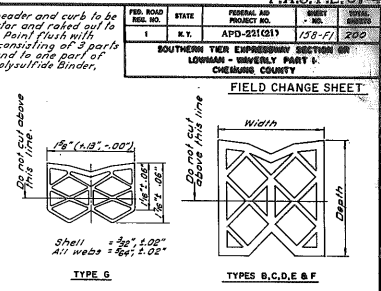
SECTION C-C
Scale: 1/2"=1'-0"



SECTION E-E
Scale: 1/2"=1'-0"



SECTION F-F
No Scale



FIELD CHANGE SHEET

DIMENSIONS FOR TYPES B, C, D, E & F

TYPE	WIDTH	DEPTH	SHELL THICKNESS	WEBS
B	12" x 12"	2" x 12"	1/2"	2"
C	24" x 12"	2" x 12"	1/2"	2"
D	24" x 24"	2" x 12"	1/2"	2"
E	36" x 24"	2" x 12"	1/2"	2"
F	48" x 24"	2" x 12"	1/2"	2"

Any changes in the shape or dimensions of Preformed Elastic Joint Sealer must be approved by the Deputy Chief Engineer. Design. The minimum thickness of any webs shall not be less than as specified. The average thickness of all webs shall be within the tolerances specified.

PREFORMED ELASTIC JOINT SEALER - M38PC
No Scale

APPROVED
1/1/68
[Signature]

Note: "R" is the amount that "R" must be decreased for every 10° rise in temperature or increased for every 10° fall in temperature.

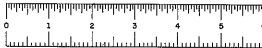
ABUT. TYPE	M38PC	R	S	X	T
West	1	2 1/2	3/4	-	-
East	2	1 1/2	1 1/4	1 1/2	-

REPRESENTATIVE of Waterstop Installation
see Dwg. No. 8.

BRIDGE NO. 3
EXPRESSWAY OVER CHENING RIVER
JOINT DETAILS

By: [Signature]	Date:	Scale:
Checked: [Signature]		
Design: [Signature]		
Drawn: [Signature]		
Revised: [Signature]		

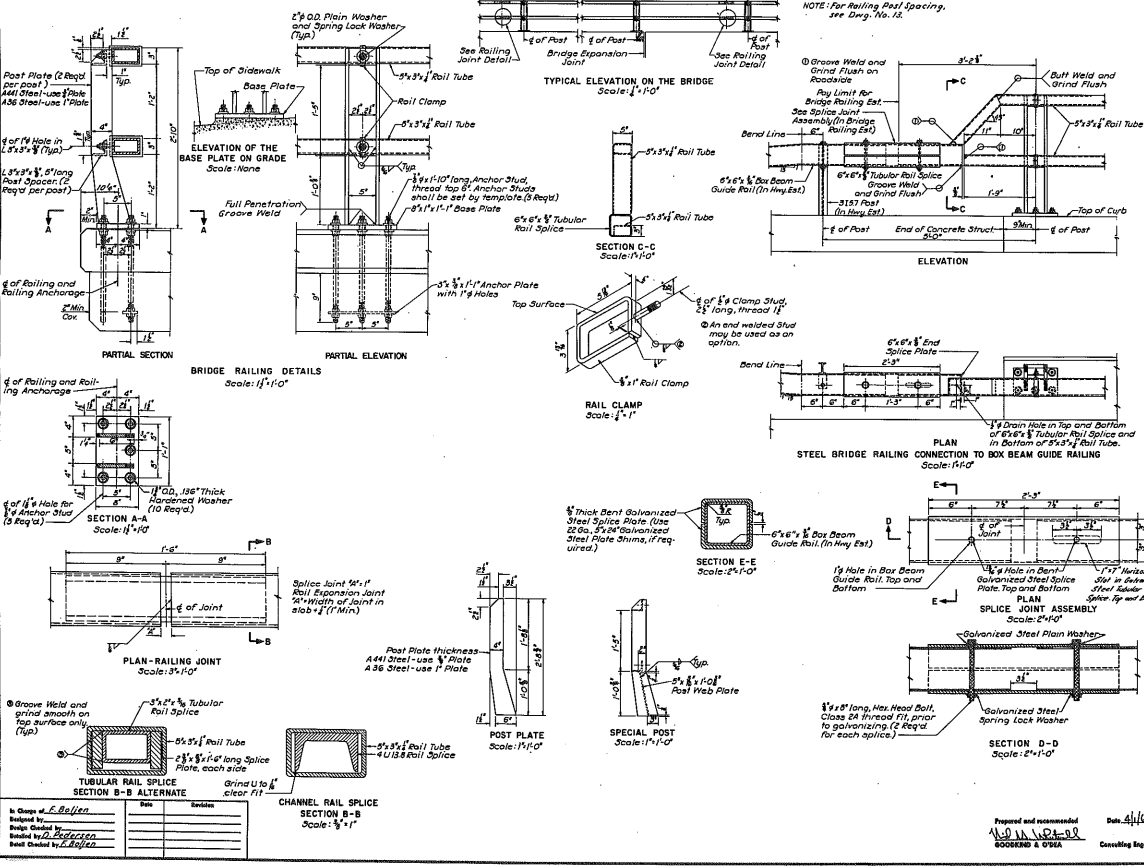
Prepared and recommended by: [Signature]	Checked by: [Signature]
Reviewed by: [Signature]	Consulting Engineer



FED. ROAD REG. NO.	STATE	FEDERAL AID PROJECT NO.	SHEET NO.	TOTAL SHEETS
1	N.Y.	APD-221(21)	159	200

SOUTHERN TIER EXPRESSWAY SECTION 6R
LOWWAY - MAINTENANCE PART I
CHEMUNG COUNTY

NOTE: Grind corners of post plate to 1/4" radius.



Notes:

All railing is to be fabricated and erected so that the rails are parallel to each other and to the parapet and so that the posts are truly vertical.

Since the finished railing must meet all requirements of fit, alignment, grade and verticality of post to the full satisfaction of the Engineer, it is suggested that complete field measurements be made before any shop fabrication is performed.

The Base Plates shall be perpendicular to the post unless otherwise noted. When the railing is to be placed on a prepared surface, the Base Plate may be parallel to the grade or may be perpendicular to the post and made level by the use of leveled shims.

Tubular steel rails, rail clamp assemblies including studs, nuts and washers, posts, post caps if required, splice plates, base plates, splice joints and splice joint railing assemblies including steel bridge railing connection to the box beam guide railing and any necessary shims and/or pads shall be held for under the railing face.

Anchor studs, nuts, washers and anchor plates shall be held for under the railing face.

After the anchor stud nuts have been placed and tightened to the satisfaction of the Engineer, the studs shall be cut off 1/8" above the nut and headed.

Posts shall be continuous over a minimum of three posts. On "TOP" type wireposts the rails may be continuous over two posts.

Materials used in the manufacture of this railing shall conform to the requirements and/or specifications listed below:

Rail Tubes - ASTM Designation A500 Grade B A500

Rail Clamps - ASTM Designation A36

Clamp studs, nuts and washers - ASTM Designation A307

Chemical Rail Splices - ASTM Designation A36 Grade B or A500

Splice Plates - ASTM Designation A36

3/4" Post Plates - ASTM Designation A441

1" Post Plates - ASTM Designation A36

Post Spacers - Same as post plate material

Base Plates - Same as post plate material

Splice Bolts, nuts and washers - ASTM Designation A307

Anchor studs, nuts and washers - ASTM Designation A36

Anchor Plates - ASTM Designation A36

Post Web Plates - Same as post plate material

Plate Shims - ASTM Designation A36

Revealed Shims - Material Specification M12

Galvanized Railing - All components of the railing including anchor studs, nuts, and washers shall be galvanized in accordance with Material Specification M12. Anchor studs shall have a Class 2A thread fit prior to galvanizing. The cut portion of the anchor studs shall be given one field coat of Gall Group Primer and two field coats of leady Zinc Aluminous Paint conforming to the requirements of Material Specifications M120 and M121 in that order.

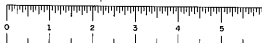
BRIDGE NO. 3
EXPRESSWAY OVER CHEMUNG RIVER
RAILING DETAILS

Prepared and recommended by: **ROCKWELL & O'SHA**
Date: **4/1/64**
Consulting Engineer

Checked by: **G. J. O'SHA**
Date: **4/1/64**
Consulting Engineer

DWG. NO.	SCALE	DATE	GOODWIN & O'NEAL CONSULTING ENGINEERS
15 of 16	As Shown	4/1/64	

In Charge of E. R. O'SHA
Designed by: _____
Checked by: G. J. O'SHA
Revised by: E. R. O'SHA

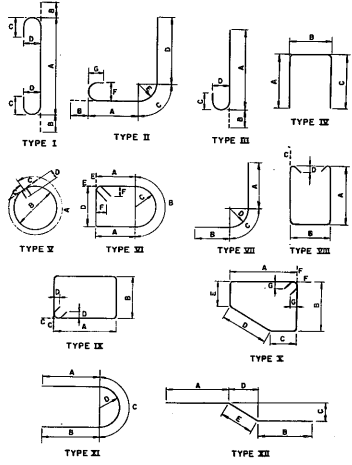


FED. ROAD DIST. NO.	STATE	FEDERAL AID PROJECT NO.	SHEET NO.	TOTAL SHEETS
1	W.V.	APD-221(C13)	160	200

SOUTHERN TIER EXPRESSWAY SECTION GR
LOWMAN - WAVELY PART I
CHEMUNG COUNTY

MARK	TYPE	LENGTH	QUANTITY	DIMENSIONS							NOTES	
ABUTMENTS (4 REQUIRED)				TOTAL PER UNIT	A	B	C	D	E	F	G	
JAS71	SA	2'-6"	304	76								
JAS72	SA	6'-6"	288	76								
JAS73	SA	6'-6"	288	76								
JAS74	SA	21'-0"	40	10								
JAS75	SA	20'-0"	40	10								
JAS76	SA	20'-0"	40	10								
JAS77	SA	20'-0"	40	10								
JAS78	SA	20'-0"	40	10								
JAS79	SA	20'-0"	40	10								
JAS80	SA	20'-0"	40	10								
JAS81	SA	20'-0"	40	10								
JAS82	SA	20'-0"	40	10								
JAS83	SA	20'-0"	40	10								
JAS84	SA	20'-0"	40	10								
JAS85	SA	20'-0"	40	10								
JAS86	SA	20'-0"	40	10								
JAS87	SA	20'-0"	40	10								
JAS88	SA	20'-0"	40	10								
JAS89	SA	20'-0"	40	10								
JAS90	SA	20'-0"	40	10								
JAS91	SA	20'-0"	40	10								
JAS92	SA	20'-0"	40	10								
JAS93	SA	20'-0"	40	10								
JAS94	SA	20'-0"	40	10								
JAS95	SA	20'-0"	40	10								
JAS96	SA	20'-0"	40	10								
JAS97	SA	20'-0"	40	10								
JAS98	SA	20'-0"	40	10								
JAS99	SA	20'-0"	40	10								
JAS00	SA	20'-0"	40	10								

MARK	TYPE	LENGTH	QUANTITY	DIMENSIONS							NOTES	
PIERS 3EB, 3WB, 4EB B 4WB (4 REQUIRED)				TOTAL PER UNIT	A	B	C	D	E	F	G	
SPF12	SA	6'-6"	360	90								
SPF13	SA	33'-5"	172	88								
SPF14	SA	4'-2"	364	91								
SPF15	SA	24'-0"	364	91								
SPF16	SA	2'-2"	164	41								
SPF17	SA	29'-6"	136	34								
SPF18	SA	5'-0"	128	32								
SPF19	SA	30'-7"	48	12								Δ 2'-0"
SPF20	SA	7'-3"	8	2								
SPF21	SA	3'-4"	244	61								
SPF22	SA	13'-3"	60	15								
SPF23	SA	14'-5"	72	3								



Note: All bar dimensions are out to out.

In Charge of F. Bollen
 Designed by _____
 Checked by S. N. M. M. M. M.
 Head Checked by S. N. M. M. M. M.

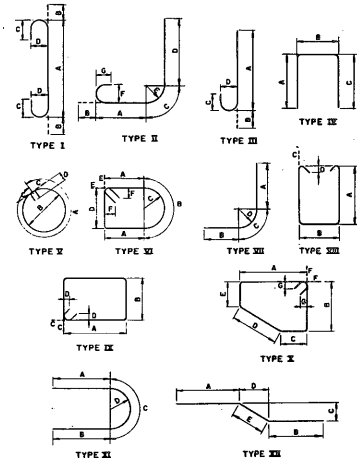
Prepared and recommended by S. N. M. M. M. M.
 GOODENOUGH & O'DEA
 Consulting Engineers

BRIDGE NO. 3
 EXPRESSWAY OVER CHEMUNG RIVER
 BAR LIST

DRAW. NO.	SCALE	DATE	GOODENOUGH & O'DEA
16 of 16	No. Scale	1/1/61	CONSULTING ENGINEERS

SOUTHERN TIER EXPRESSWAY SECTION 6R
LOWMAN - MAVERLY PART 1
CHEMUNG COUNTY

FIELD CHANGE SHEET



Note: All bar dimensions are out to out.

APPROVED
10/14/14
[Signature]
Civil Engineer

BRIDGE NO. 3
EXPRESSWAY OVER CHEMUNG RIVER
BAR LIST

DATE: 4/14/14
Scale: 1/8" = 1'-0"

Table with columns: MARK, TYPE, LENGTH, QUANTITY, TOTAL PER UNIT, DIMENSIONS (A, B, C, D, E, F, G), NOTES. Contains bar lists for Piers 3EB, 3WB, 4EB, 4WB, Piers 5EB, 5WB, 6EB, 6WB, Slab - EB & WB Spans 1 & 7, Slab - EB & WB Spans 2, 3, 4, 5 & 6, Piers 2EB & 2WB, and Approach Pavement - EB & WB.

Table with columns: MARK, TYPE, LENGTH, QUANTITY, TOTAL PER UNIT, DIMENSIONS (A, B, C, D, E, F, G), NOTES. Contains bar lists for Piers 3EB, 3WB, 4EB, 4WB, Piers 5EB, 5WB, 6EB, 6WB, Slab - EB & WB Spans 1 & 7, Slab - EB & WB Spans 2, 3, 4, 5 & 6, Piers 2EB & 2WB, and Approach Pavement - EB & WB.

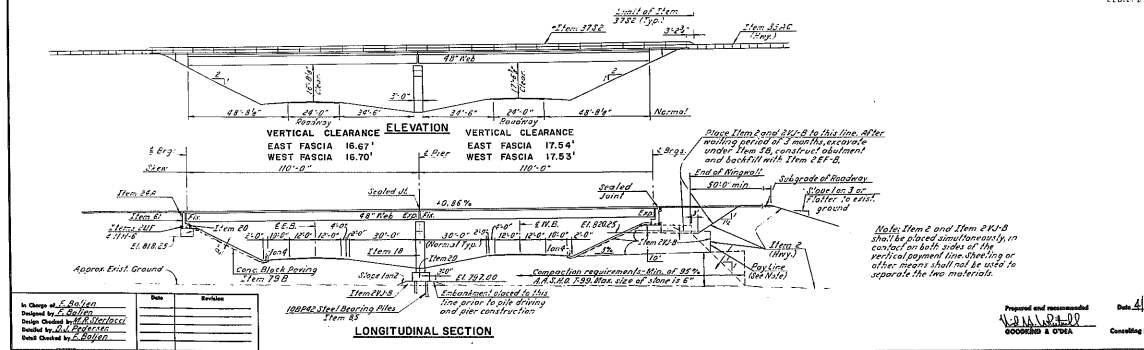
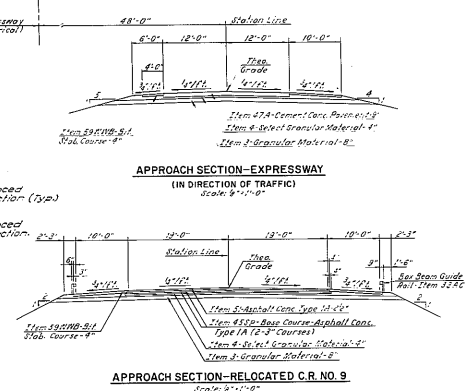
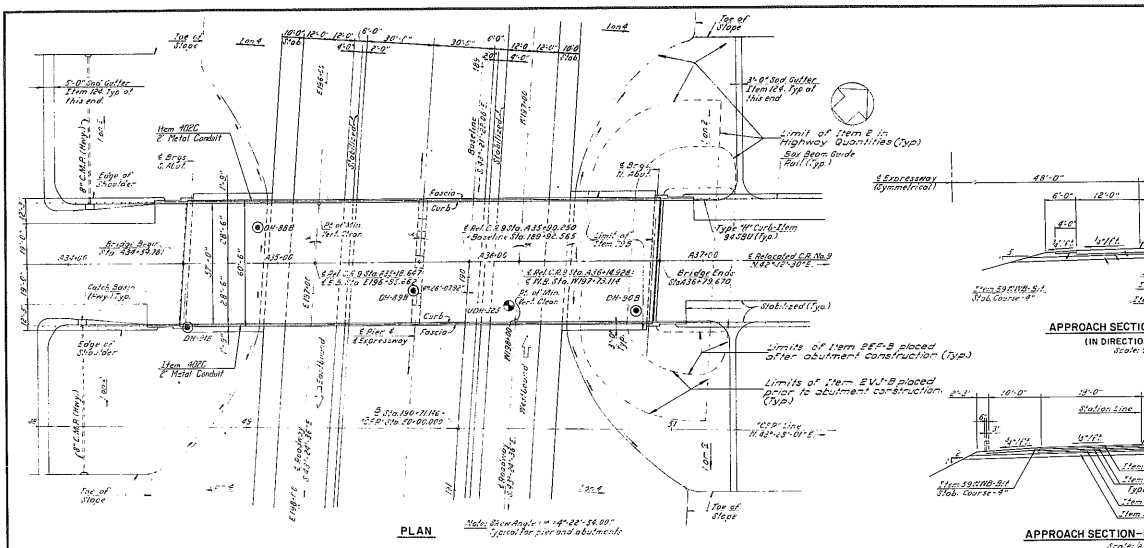
In Charge of F. B. J. [Signature]
Checked by [Signature]
Date: 10-14-14

Prepared and recommended by [Signature]
Checked by [Signature]
Date: 4/14/14

GOODWIN & ODEA
CONSULTING ENGINEERS

FED. ROAD DIST. NO.	STATE	FEDERAL AID PROJECT NO.	SHEET NO.	TOTAL SHEETS
1	N.Y.	APD-221 (21)	161 R1	199

**SOUTHERN TIER EXPRESSWAY SECTION 6R
LOWMAN - BURELY PART 1
CHEMUNG COUNTY**



NOTES:
1. For General Notes, see Div. No. 8-3
2. For Location Plan, see Div. No. 8-1
3. For Layout Plan, see Div. No. 2

REVISIONS
1. CHECKING VERTICAL CLEARANCE

BRIDGE NO. 4-I
RELOCATED C.R. NO. 9 OVER EXPRESSWAY
GENERAL PLAN AND SECTIONS

No.	Revision

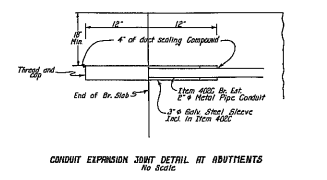
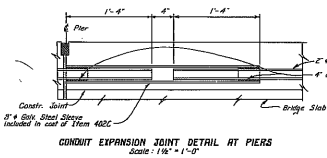
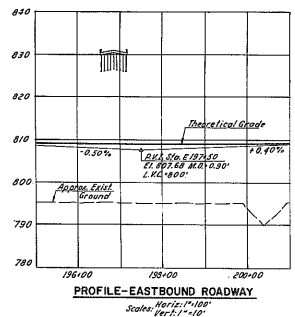
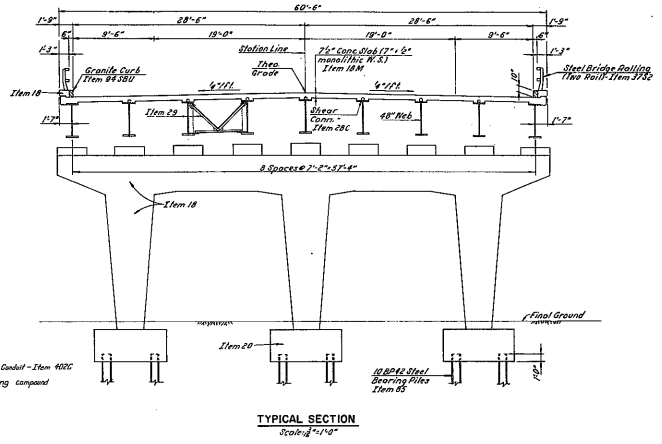
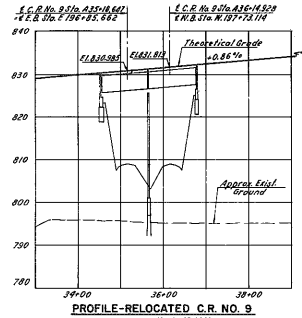
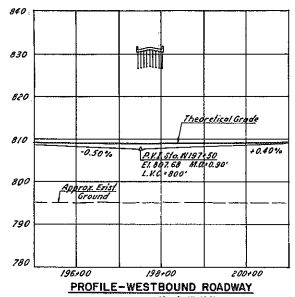
Prepared and measured by **W. H. W. & O. A.**
Checked by **W. H. W. & O. A.**
Date: **4/1/49**
Consulting Engineers: **GOODKIND & O'DEA**

DRAWN	SCALE	DATE	GOODKIND & O'DEA
1 of 14	1" = 40'	4/1/49	CONSULTING ENGINEERS



FED. ROAD DIST. NO.	STATE	FEDERAL AID PROJECT NO.	SHEET NO.	TOTAL SHEETS
1	N.Y.	APD-32(21)	762	200

**SOUTHERN TIER EXPRESSWAY SECTION 6R
LOWRIAN - BENEVELY PART 1
CHEMUNG COUNTY**



**BRIDGE NO. 4-I
RELOCATED C.R. NO. 9 OVER EXPRESSWAY
SECTIONS AND PROFILES**

Date	Revisions

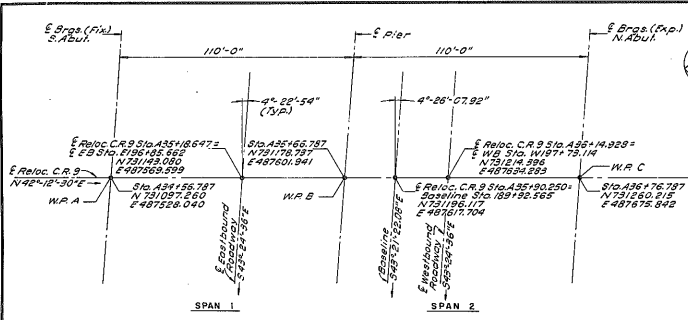
Prepared and recommended by: *[Signature]*
Checked by: *[Signature]*
Consulting Engineers

DWG. NO.	SCALE	DATE	GOODING & O'NEAL CONSULTING ENGINEERS
2 of 14	As Shown	4/1/17	

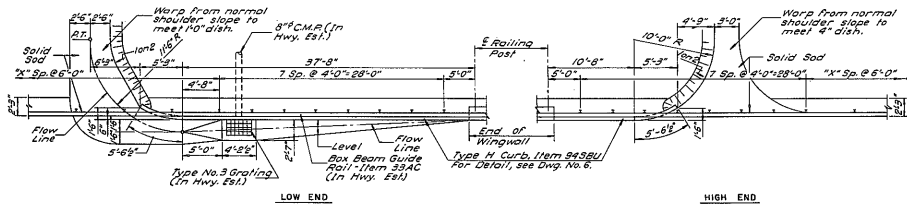


FED. ROAD DIST. NO.	STATE	FEDERAL AID PROJECT NO.	SHEET NO.	TOTAL SHEETS
1	N.Y.	APD-221(21)	63	200

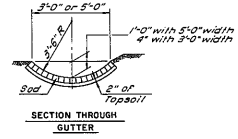
SOUTHERN TIER EXPRESSWAY SECTION 6R
LOWMAN - WAVERLY PART I
CHEMUNG COUNTY



LAYOUT PLAN
No Scale



DRAINAGE DETAILS AT ENDS OF BRIDGE
Scale: 3/8" = 1'-0"



SECTION THROUGH GUTTER

In Charge of <i>E. B. G. / J. C. G.</i>	Des.	Revised
Reviewed by <i>J. C. G.</i>		
Design Checked by <i>J. C. G.</i>		
Checked by <i>J. C. G.</i>		

BRIDGE NO. 4-I
RELOCATED C. R. NO. 9 OVER EXPRESSWAY
LAYOUT PLAN AND DRAINAGE DETAILS

Prepared and transmitted by *M. D. ...*
Checked by *J. C. G.*

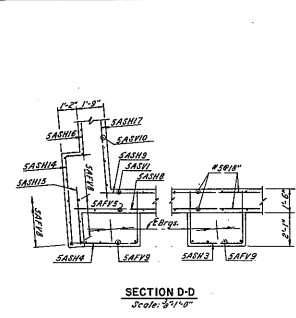
DATE: 3-21-14
SCALE: AS SHOWN
SITE: 4/1/14

GOODKIND & O'DEA
CONSULTING ENGINEERS

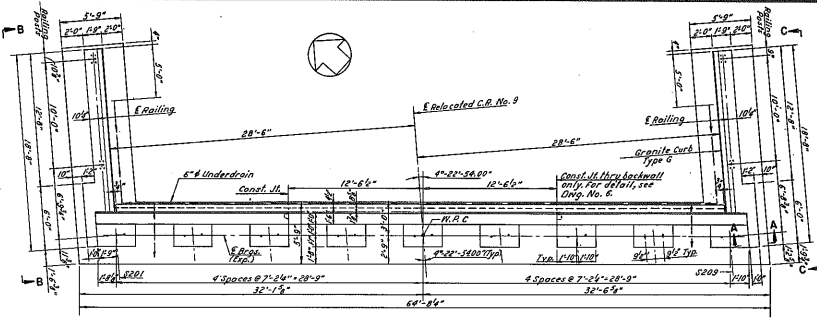


FED. ROAD DIST. NO.	STATE	FEDERAL AID PROJECT NO.	SHEET NO.	TOTAL SHEETS
1	N.Y.	APD-221(C1)	164	200

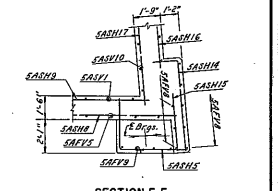
SOUTHERN TIER EXPRESSWAY SECTION 6A
LOWMAN - WARDENLY PART I
CHEMUNG COUNTY



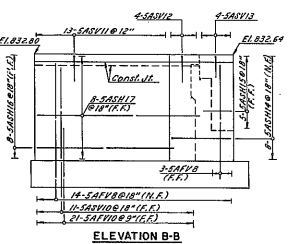
SECTION D-D
Scale: 3/4"=1'-0"



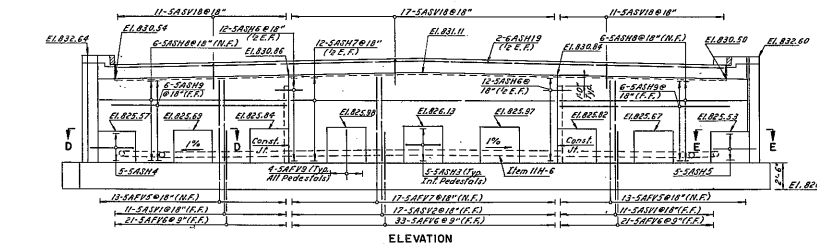
PLAN



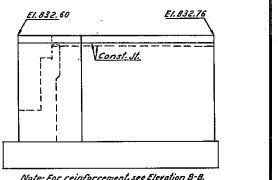
SECTION E-E
Scale: 3/4"=1'-0"



ELEVATION B-B

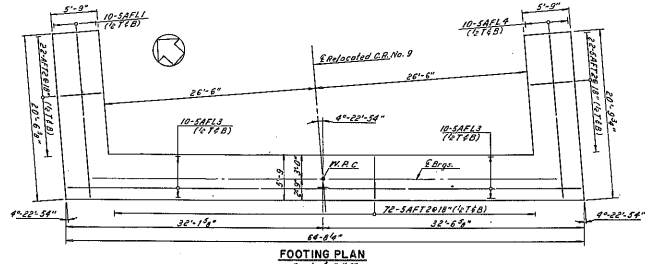


ELEVATION



ELEVATION C-C

Note: For reinforcement, see Elevation B-B.



FOOTING PLAN
Scale: 1/4"=1'-0"

NOTES:
1. For design purposes, the Foundation pressure does not exceed 2.5 tons per square foot.

- REFERENCES:
1. For Bar Lists see Dwg. No. 14
2. For Rebar Details see Dwg. No. 13
3. For Abutment Wall and Draining Details, see Dwg. No. 10
4. For Abutment Details and Section A-A, see Dwg. No. 8
5. For Layout Plans, see Dwg. No. 3.

Date	Revisions

BRIDGE NO. 4-I
RELOCATED C.R. NO. 9 OVER EXPRESSWAY
NORTH ABUTMENT

Prepared and recommended by
GOODING & OYEA

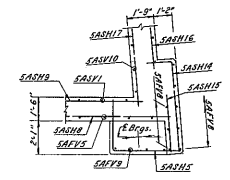
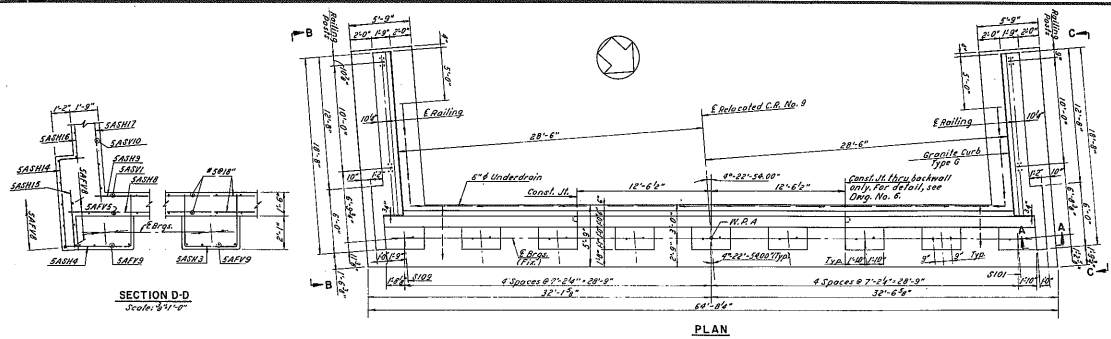
Date: 4/1/74
Consulting Engineers

DWG. NO.	SCALE	DATE	GOODING & OYEA CONSULTING ENGINEERS
4 of 16	1/4"=1'-0"	4/1/74	



FED. ROAD DIST. NO.	STATE	FEDERAL AID PROJECT NO.	SHEET NO.	TOTAL SHEETS
1	N.Y.	APD-231013	165	200

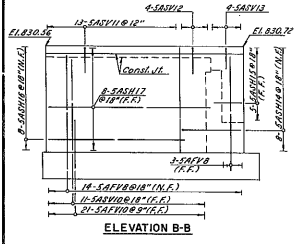
SOUTHERN TIER EXPRESSWAY SECTION 04
LOWMAN - WAVERLY PART I
CHEMUNG COUNTY



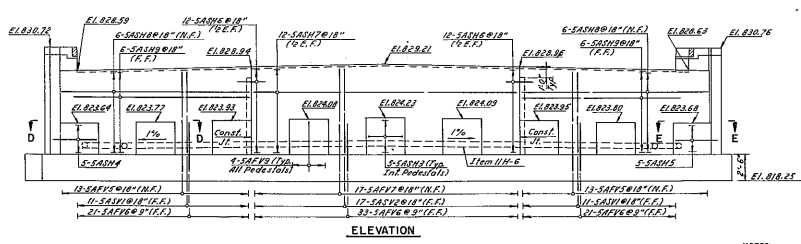
SECTION E-E
Scale: 3/4"=1'-0"

SECTION D-D
Scale: 3/4"=1'-0"

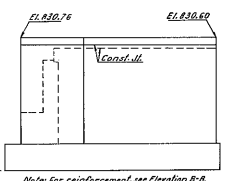
PLAN



ELEVATION B-B

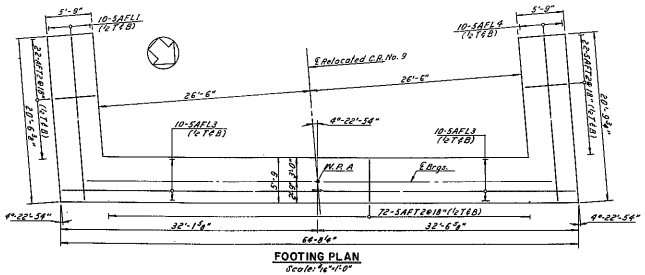


ELEVATION



ELEVATION C-C

Note: For reinforcement, see Elevation B-B.



FOOTING PLAN
Scale: 3/4"=1'-0"

NOTES:
1. For design purposes, the foundation pressure does not exceed 2.5 tons per square foot.

- REFERENCES:
1. For Bar L13, see Dwg. No. 14.
2. For Bar L15, see Dwg. No. 13.
3. For Anchor Bolt and Bearing Details, see Dwg. No. 10.
4. For Abutment Details and Section A-A, see Dwg. No. 6.
5. For Layout Plans, see Dwg. No. 3.

In Charge of <i>E. D. Miller</i>	Rev.	Revised
Designed by <i>M. J. G. Kelly</i>		
Design Checked by <i>H. J. G. Kelly</i>		
Drawn by <i>D. J. G. Kelly</i>		
Steel Checked by <i>E. D. Miller</i>		

Prepared and recommended by *M. J. G. Kelly*
Checked by *E. D. Miller*
Consulting Engineers

Date: 4/1/64
Drawing Engineer

BRIDGE NO. 4-I
RELOCATED C.R. NO. 9 OVER EXPRESSWAY
SOUTH ABUTMENT

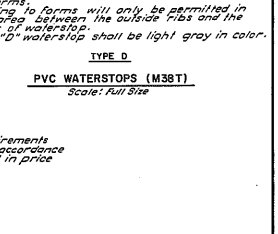
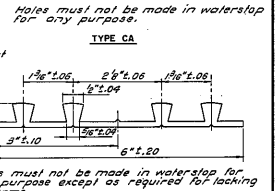
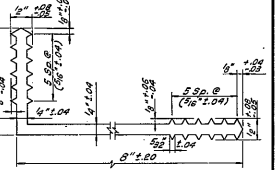
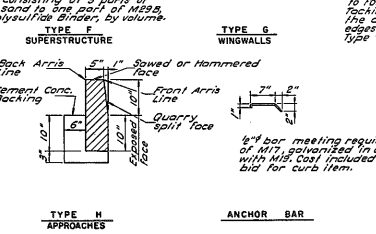
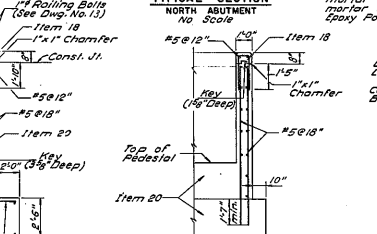
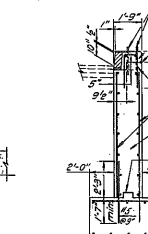
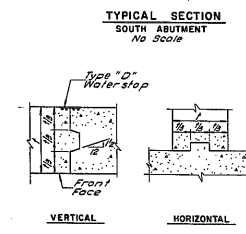
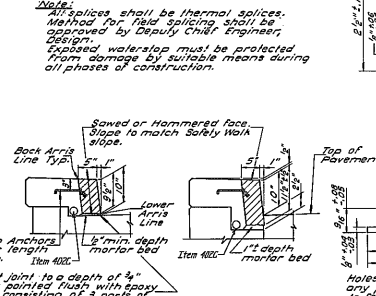
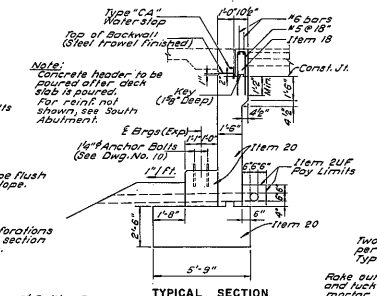
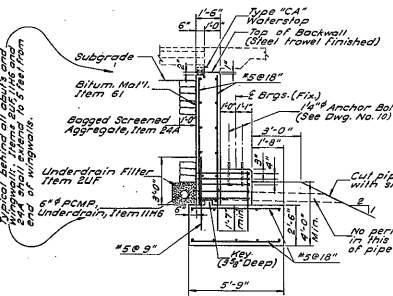
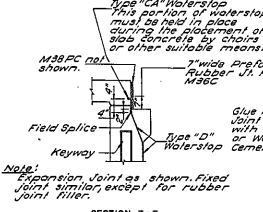
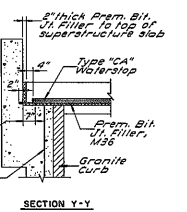
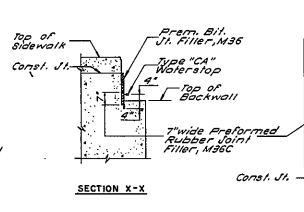
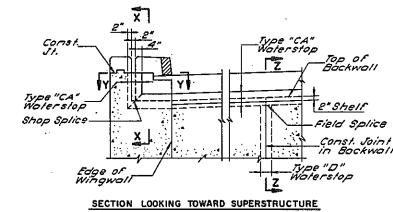
DWG. NO.	DATE	BY	CHKD.
50714	4/1/64	M. J. G. Kelly	E. D. Miller

GOODING & ODEA
CONSULTING ENGINEERS



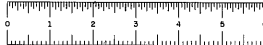
FED. ROAD DIST. NO.	STATE	FEDERAL AID PROJECT NO.	SHEET NO.	TOTAL SHEETS
1	N.Y.	APD-321(21)	166	200

SOUTHERN TIER EXPRESSWAY SECTION 6R
LAWMAN - WAVERLY PART 1
CHEMUNG COUNTY



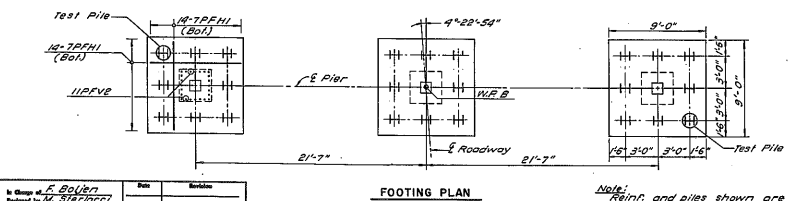
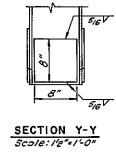
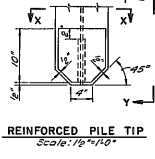
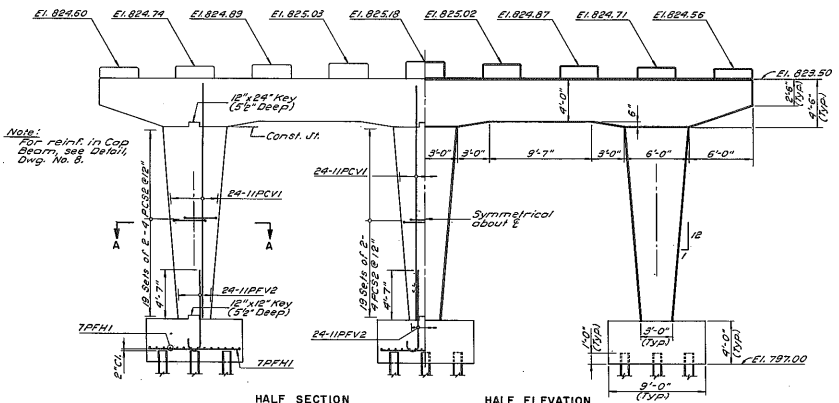
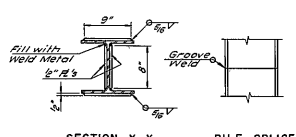
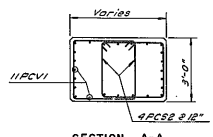
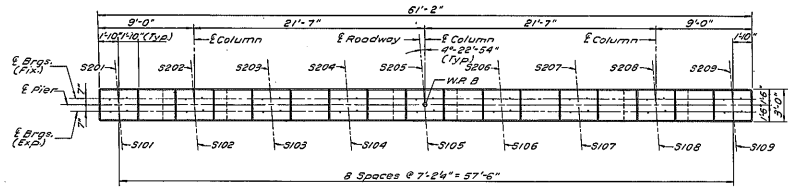
Rev.	By	Notes
1	F. B. Grier	
2	A. M. Grier	
3	A. M. Grier	
4	A. M. Grier	
5	A. M. Grier	

DWG. NO.	SCALE	DATE	GOODING & O'NEAL CONSULTING ENGINEERS
6 of 14	As Shown	4/11	



FED. ROAD REG. NO.	STATE	FEDERAL AID PROJECT NO.	SHEET NO.	TOTAL SHEETS
1	K.Y.	APD-221(211)	167	200

SOUTHERN TIER EXPRESSWAY SECTION 6R
LOWMAN - WAVERLY PART I
CHEMUNG COUNTY



PILE NOTES:

- All piles to be 10BR42 Steel Bearing Piles.
- For design purposes the pile load does not exceed 50 tons per pile.
- Estimated length of Piles is 80 ft.
- Ordered length of 1st pile is 90 ft.
- The ordered length of pile shall be measured below the cut-off elevation shown on the plans. Any additional lengths of pile or splices above the cut-off elevation necessary to facilitate the Contractor's operation shall be at his own expense.

REFERENCES:

- For Layout Plan, see Dwg. No. 3.
- For Pier Details, see Dwg. No. 5.
- For Bar List, see Dwg. No. 14.

BRIDGE NO. 4-I
RELOCATED C.R. NO. 9 OVER EXPRESSWAY
PIER

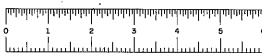
In Charge of	Date	Revised
<i>F. Bolten</i>		
<i>M. Staljeck</i>		
<i>W. L. Johnson</i>		
<i>E. R. Johnson</i>		
<i>E. R. Johnson</i>		

Notes:
Rein. and piles shown are typical for each Column Footing.

Prepared and recommended by
W. L. Johnson
GOODKIND & ODEA

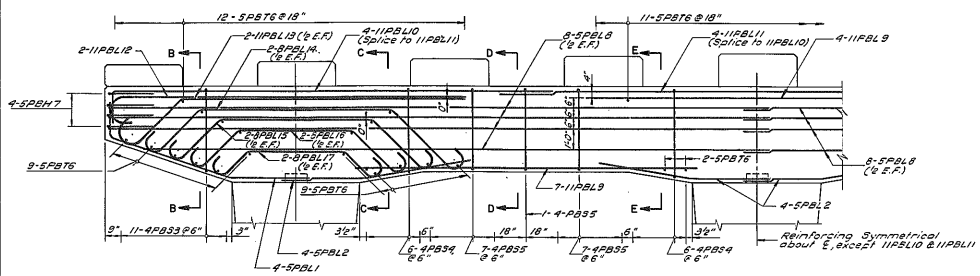
Date: 4/1/49
Consulting Engineers

DWG. NO.	SCALE	DATE	GOODKIND & ODEA CONSULTING ENGINEERS
70714	6"=1'-0"	4/1/49	

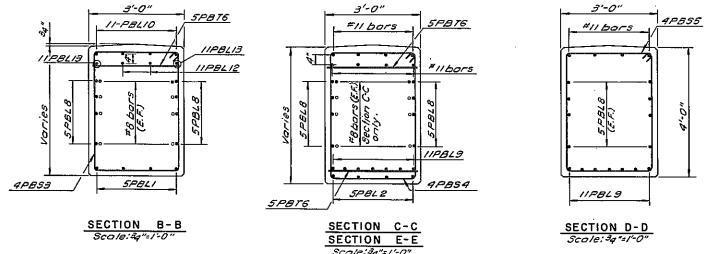


FED. ROAD DIST. NO.	STATE	FEDERAL AID PROJECT NO.	SHEET NO.	TOTAL SHEETS
1	N.Y.	APD-22(C)17	168	200

SOUTHERN TIER EXPRESSWAY SECTION 6R
LOWMAN - WAVERLY PART I
CHEMUNG COUNTY



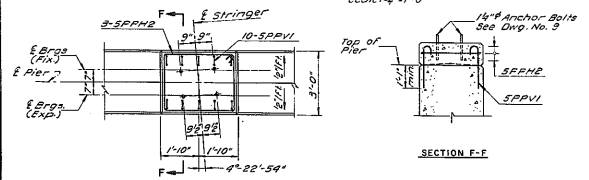
CAP BEAM DETAIL
Scale: 3/4" = 1'-0"



SECTION B-B
Scale: 3/4" = 1'-0"

SECTION C-C
Scale: 3/4" = 1'-0"

SECTION D-D
Scale: 3/4" = 1'-0"



PEDESTAL DETAILS
Scale: 3/4" = 1'-0"

REFERENCES:
1. For Bar List, see Dwg. No. 14.

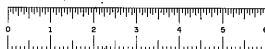
BRIDGE NO. 4-I
RELOCATED C. R. NO. 9 OVER EXPRESSWAY
PIER DETAILS

In Charge of	Date	Revision
<i>L. Edlin</i>		
<i>J. J. O'Kea</i>		
<i>W. J. O'Kea</i>		
<i>J. J. O'Kea</i>		
<i>J. J. O'Kea</i>		

Prepared and recommended
W. J. O'Kea
GOODKIND & O'KEA

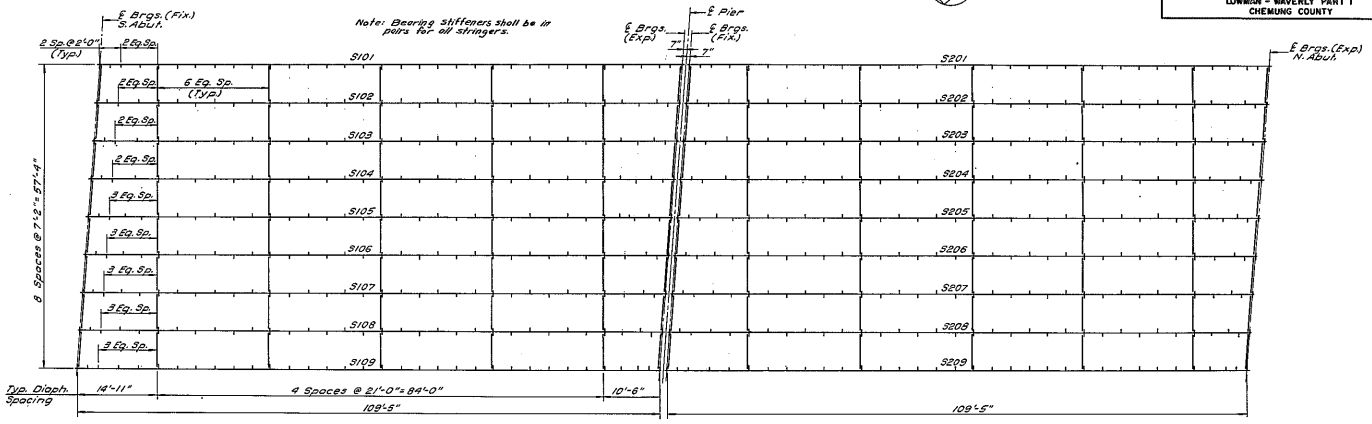
Date: *4/1/47*
Consulting Engineer

ENR. NO.	SCALE	DATE	GOODKIND & O'KEA CONSULTING ENGINEERS
<i>8 of 14</i>	<i>AS SHOWN</i>	<i>4/1/47</i>	

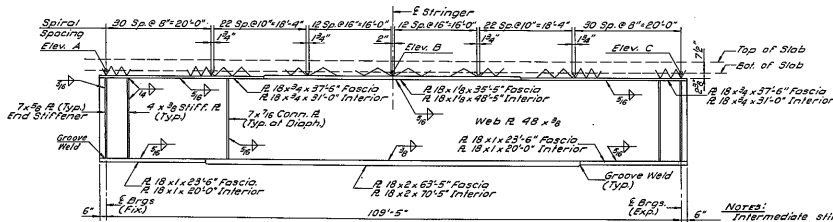


FED. ROAD REC. NO.	STATE	FEDERAL AID PROJECT NO.	SHEET NO.	TOTAL SHEETS
1	N.Y.	APD-221(21)	169	200

SOUTHERN TIER EXPRESSWAY SECTION 6R
LOWLAND - HAVERLY PART 1
CHEMUNG COUNTY



FRAMING PLAN
Scale: 1/8" = 1'-0"



STRINGER ELEVATION
No Scale

MARK	A	B	C
S101	828.25	828.12	830.89
S102	828.40	828.27	830.94
S103	828.54	830.01	830.48
S104	828.68	830.15	830.62
S105	828.82	830.30	830.77
S106	828.96	830.15	830.62
S107	829.10	829.39	830.46
S108	829.24	829.24	830.31
S109	829.38	829.68	830.15
S201	830.20	830.67	831.41
S202	830.35	830.65	831.49
S203	830.49	830.36	831.43
S204	830.64	831.11	831.58
S205	830.78	831.25	831.72
S206	830.93	831.10	831.57
S207	831.07	830.94	831.41
S208	831.22	830.79	831.26
S209	831.36	830.64	831.11

STRINGER	STEEL ONLY	TOTAL
Interior	1/4"	3/8"
Fascia	1/8"	2 1/8"

Vertical Curve Camber = 0"
Camber measured along S Stringer

Notes:
Intermediate stiffeners for interior stringers shall be staggered on each side of the web.
Intermediate stiffeners for fascia stringers shall be placed on the inside face of web.
Use General Notes for methods of connecting stiffeners.
Bottom flanges to be cut to 1/2" width at bearings. See Detail, Dwg. No. 10.

REFERENCES:
1. For General Notes, see Dwg. No. S-3.
2. For Steel Details, see Dwg. No. 10.
3. For Layout Plans, see Dwg. No. 3.

BRIDGE NO. 4-I
RELOCATED C. R. NO. 8 OVER EXPRESSWAY
FRAMING PLAN

In Charge of C. Bolten	Date	Revised
Designed by C. Bolten		
Bridge Checked by M. Stenger		
Modified by C. Bolten		
Steel Checked by E. Bolten		

Prepared and recommended
GODDARD & O'DEA

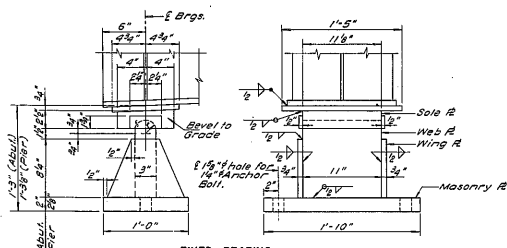
Date: 4/1/49
Consulting Engineers

DRAW. NO.	SCALE	DATE	GOODKIND & O'DEA CONSULTING ENGINEERS
S of 16	As Shown	4/1/49	

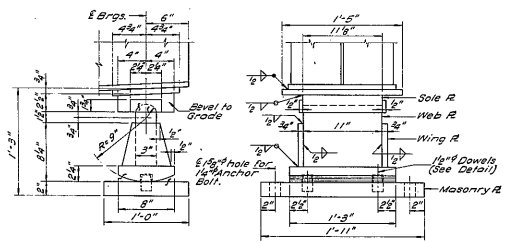


FED. ROAD DIST. NO.	STATE	FEDERAL AID PROJECT NO.	SHEET NO.	TOTAL SHEETS
1	N.Y.	APP-231(013)	170	200

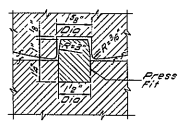
SOUTHERN TIER EXPRESSWAY SECTION 6R
LOWMAN - WAVERLY PART I
CHEMUNG COUNTY



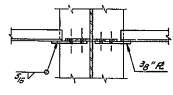
r = 1/4" for Web R
r = 1/8" for Sole R



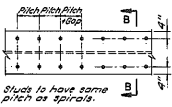
EXPANSION BEARING
Scale: 2' = 1'-0"



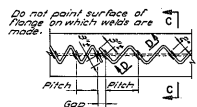
DOWEL DETAIL
Scale: Half Size



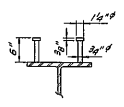
SECTION A-A
Scale: 1' = 1'-0"



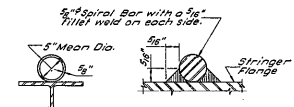
PARTIAL PLAN OF STUDS
No Scale



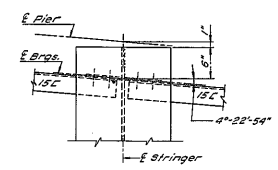
PARTIAL PLAN OF SPIRALS
No Scale



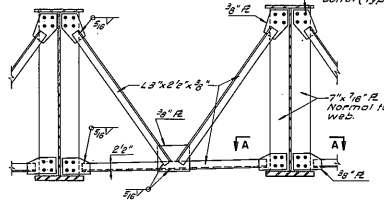
SECTION B-B
No Scale



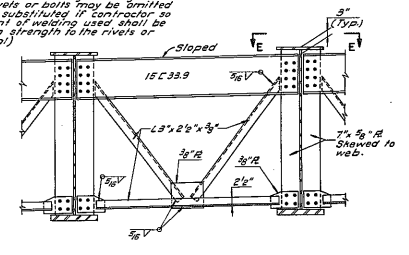
SECTION D-D
Full Size



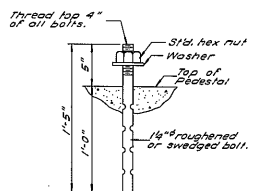
SECTION E-E
Scale: 1/2" = 1'-0"



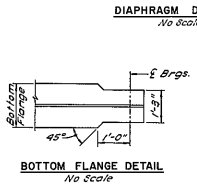
INTERMEDIATE



END



ANCHOR BOLT DETAIL
No Scale



BOTTOM FLANGE DETAIL
No Scale

DIAPHRAGM DETAILS
No Scale

REPRODUCED FOR Framing Plan, see Dwg. No. 8.

In Charge of	Date	Revision
R. Boljen		
Designed by		
Checked by		
Reviewed by		
Field Checked by		

BRIDGE NO. 4-I
RELOCATED C. R. NO. 9 OVER EXPRESSWAY
STEEL DETAILS

Prepared and recommended
NOV 14 1949
GOODKIND & OYEA
Consulting Engineers

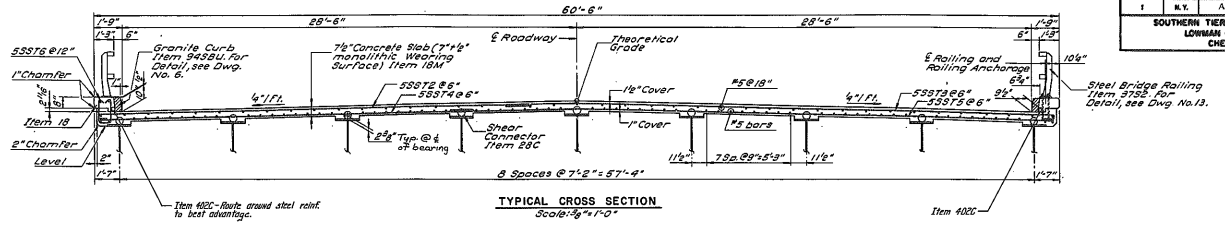
Date: 11/19/49
Consulting Engineers

DWG. NO.	SCALE	DATE	GOODKIND & OYEA CONSULTING ENGINEERS
100P19	AS SHOWN	11/19/49	

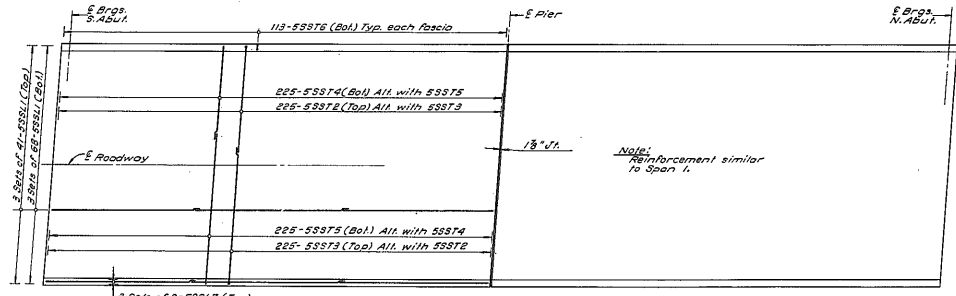


FED. ROAD DIST. NO.	STATE	FEDERAL AID PROJECT NO.	SHEET NO.	TOTAL SHEETS
1	N.Y.	APD-22(21)	171	200

SOUTHERN TIER EXPRESSWAY SECTION 6R
LOWMAN - HAVERLY PART I
CHEMUNG COUNTY

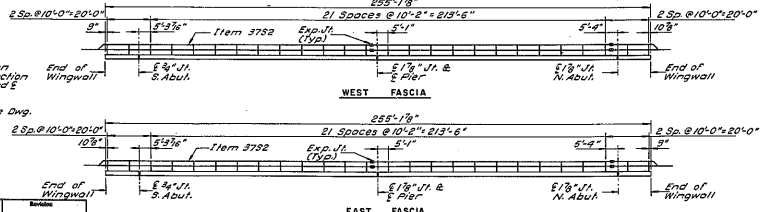


TYPICAL CROSS SECTION
Scale: 3/8" = 1'-0"



SLAB PLAN
Scale: 3/8" = 1'-0"

REFERENCES:
For Dor. List, see Dwg. No. 14.



TYPICAL RAILING ELEVATION
No Scale

In Charge of	By	Check
C. E. Solten		
Designed by		
Checked by		
Drawn by		
Scale Checked by		

BRIDGE NO. 4-I
RELOCATED C. R. NO. 9 OVER EXPRESSWAY
SLAB PLAN AND CROSS SECTION

Prepared and recommended
by
GOODING & O'DEA

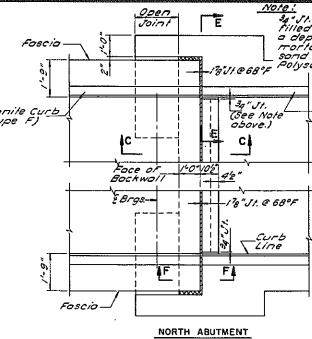
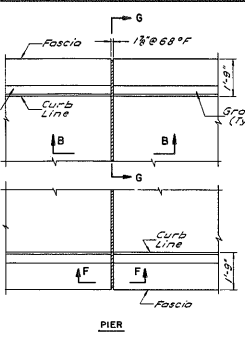
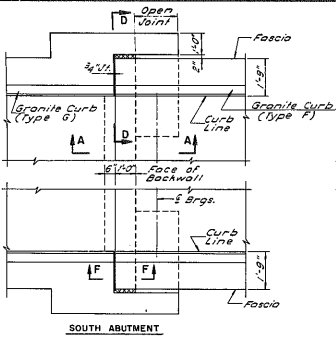
Date: 11/19/49
Consulting Engineer

SHEET NO.	SCALE	DATE	GOODING & O'DEA CONSULTING ENGINEERS
11 OF 18	AS SHOWN	11/19/49	

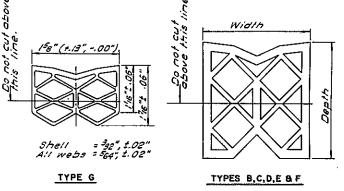


FED. ROAD DIST. NO.	STATE	FEDERAL AID PROJECT NO.	SHEET NO.	TOTAL SHEETS
1	N.Y.	APD-231(21)	172	200

SOUTHERN TIER EXPRESSWAY SECTION 6R
LOWMAN - WAVERLY PART I
CHEMUNG COUNTY



1/2" between header and curb to be filled with mortar and tamped to a depth of 1/2". Joint flush with epoxy mortar consisting of 3 parts of mortar sand to one part of M38B Epoxy Polyacrylate Binder, by volume.

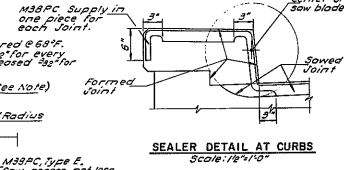


Shell = 3/8" x 1.02"
All webs = 3/8" x 1.02"

TYPE	WIDTH	DEPTH	THICKNESS	
			SHELL	WEBS
B	1 1/2"	2"	3/8"	3/8"
C	2"	2 1/2"	3/8"	3/8"
D	2 1/2"	3"	3/8"	3/8"
E	3"	3 1/2"	3/8"	3/8"
F	4"	4 1/2"	3/8"	3/8"

Any changes in the shape or dimensions of preformed elastic joint sealer must be approved by the Deputy Chief Engineer, Design. The minimum thickness of any web shall not be less than as specified. The average thickness of all webs shall be within the tolerances specified.

PREFORMED ELASTIC JOINT SEALER - M38PC



SEALER DETAIL AT CURBS
Scale: 1/2" = 1'-0"

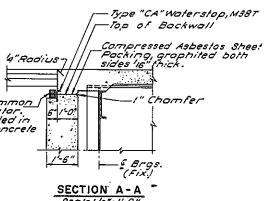
BRIDGE NO. 4-I
RELOCATED C.R. NO. 9 OVER EXPRESSWAY
JOINT DETAILS

SOUTH ABUTMENT

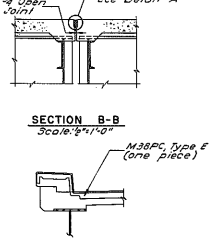
PIER

NORTH ABUTMENT

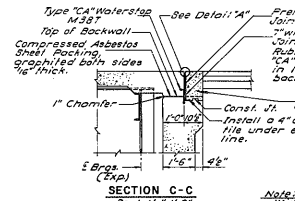
PLAN
Scale: 1/8" = 1'-0"



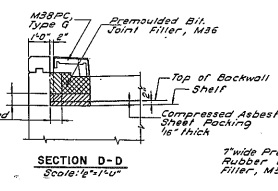
SECTION A-A
Scale: 1/2" = 1'-0"



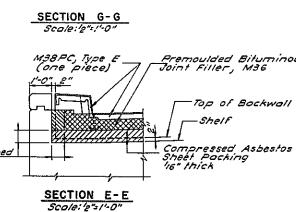
SECTION B-B
Scale: 1/2" = 1'-0"



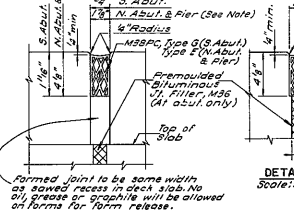
SECTION C-C
Scale: 1/2" = 1'-0"



SECTION D-D
Scale: 1/2" = 1'-0"



SECTION E-E
Scale: 1/2" = 1'-0"

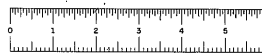


SECTION F-F
No Scale

Prepared and recommended by W. J. O'DEA
Reviewed by C. O'DEA
Checked by J. J. O'DEA

DATE	SCALE	BY	CHECKED
12/1/14	As Shown	WJO	CO

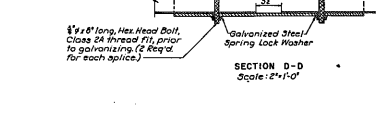
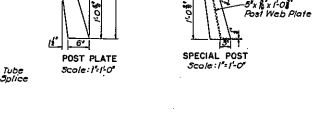
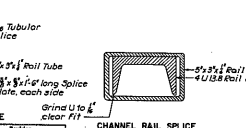
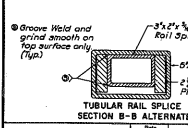
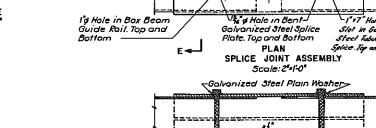
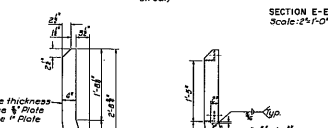
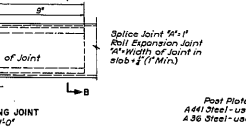
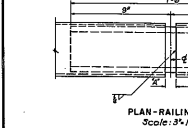
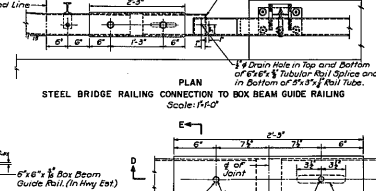
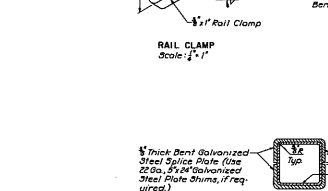
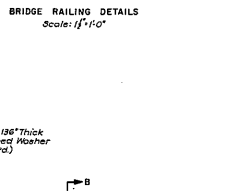
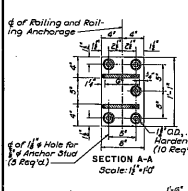
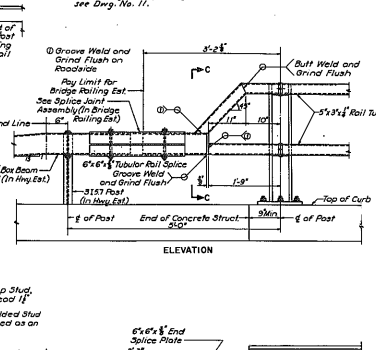
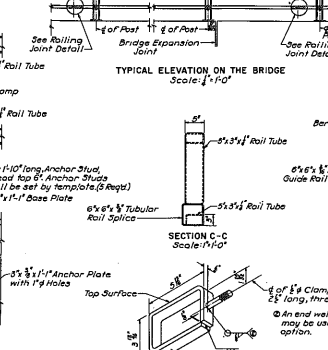
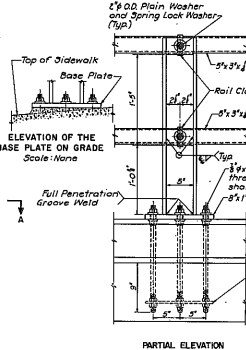
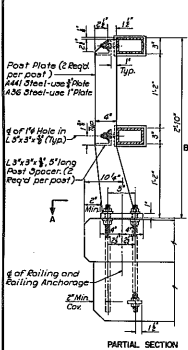
In Charge of C. O'Brien	Drawn by W. J. O'Dea
Checked by J. J. O'Dea	Design checked by C. O'Brien
Design checked by W. J. O'Dea	Design checked by W. J. O'Dea
Design checked by W. J. O'Dea	Design checked by W. J. O'Dea



FED. ROAD DIST. NO.	STATE	FEDERAL AID PROJECT NO.	SHEET NO.	TOTAL SHEETS
1	N.Y.	APD-221(21)	173	200

SOUTHERN TIER EXPRESSWAY SECTION 6R
LOWMAN - WAVERLY PART 1
CHEMUNG COUNTY

NOTE: Grind corners of post plate to $\frac{1}{4}$ " radius.



In Charge of F. Ballou	Date	Revised

NOTE: Rail railing is to be fabricated and erected so that the rails are parallel to each other and to the parapet and so that the posts are truly vertical. Since the finished railing must meet all requirements of fit, alignment, grade and verticality of post to the full satisfaction of the engineer, it is expected that complete field measurements be made before any shop fabrication is performed. The base plates shall be perpendicular to the post unless otherwise noted. When the railing is to be placed on a prepared surface, the base plates may be parallel to the grade or may be perpendicular to the post and made level by the use of beveled shims. Tubular steel rails, rail clamp assemblies including studs, nuts and washers, posts, post caps if required, post spacers, base plates, expansion joints and splice joint railing assemblies including steel bridge railing connection to the box beam guide railing and any necessary shims and/or nuts shall be paid for under the railing item. Anchor studs, nuts, washers and anchor plates shall be paid for under item 29. After the anchor stud nuts have been placed and tightened to the satisfaction of the Engineer, the studs shall be cut off $\frac{1}{8}$ " above the nut and penknives shall be continuous over a minimum of three posts. $2\frac{1}{2}$ " type stopwells the rails may be continuous over two posts. Materials used in the manufacture of this railing shall conform to the requirements and/or specifications listed below. Rail Tube - ASTM Designation A500 Grade B. ADU. Rail Clamps - ASTM Designation A36 Clamp studs, nuts and washers - ASTM Designation A307 Channel Rail Splices - ASTM Designation A58 Tubular Rail Splices - ASTM Designation A500 Grade B or ADU. Splice Plates - ASTM Designation A36 $2\frac{1}{2}$ " Post Plates - ASTM Designation A441 $2\frac{1}{2}$ " Post Plates - ASTM Designation A36 Post Spacers - Same as post plate material Splice bolts, nuts and washers - ASTM Designation A307 Anchor studs, nuts and washers - ASTM Designation A449 Post Web Plates - Same as post plate material Grade Shims - ASTM Designation A36 Beveled Shims - Material Specification M3 Galvanized Railing - All components of the railing including anchor studs, nuts, and washers shall be galvanized in accordance with Material Specification M19. Anchor studs shall have a Class 28 ball bearing primer and two field coats of heavy-duty Aluminum Paint conforming to the requirements of Material Specifications M19C and M20 in that order.

BRIDGE NO. 4-I
RELOCATED C.R. NO. 9 OVER EXPRESSWAY
RAILING DETAILS

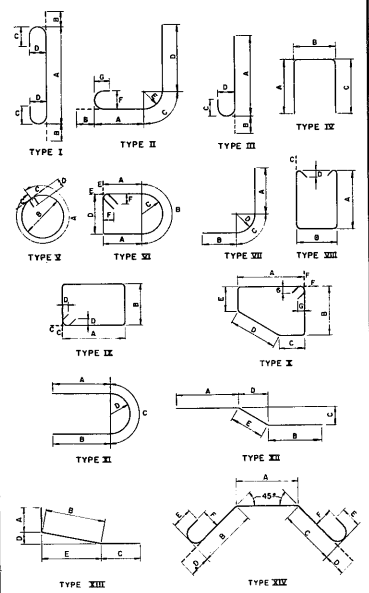
Prepared and recommended by: *[Signature]*
Checked by: *[Signature]*
Consulting Engineers

DATE: 12-1-14
SCALE: As Shown
DATE: 11/14

GOODWIN & O'DEA CONSULTING ENGINEERS

MARK	TYPE	LENGTH	QUANTITY TOTAL PER UNIT	DIMENSIONS							NOTES
				A	B	C	D	E	F	G	
NORTH ABUTMENT (1 REQUIRED)											
3AF17	SI	2'-2"	116								
3AF18	SI	3'-2"	116								
3AF19	SI	2'-2"	21								
3AF20	SI	18'-0"	10								
3AF21	SI	9'-2"	22								
3AF22	SI	9'-2"	22								
3AF23	SI	3'-0"	17								
3AF24	SI	10'-2"	34								
3AF25	SI	4'-0"	26								
3AF26	SI	1'-0"	86								
3AF27	SI	7'-2"	22								
3AF28	SI	2'-2"	17								
3AF29	SI	2'-2"	33								
3AF30	SI	7'-2"	3								
3AF31	SI	2'-2"	3								
3AF32	SI	2'-2"	33								
3AF33	SI	7'-2"	3								
3AF34	SI	2'-2"	34								
3AF35	SI	24'-2"	12								
3AF36	SI	18'-2"	12								
3AF37	SI	6'-2"	22								
3AF38	SI	18'-2"	12								
3AF39	SI	16'-2"	12								
3AF40	SI	6'-2"	22								
3AF41	SI	18'-2"	12								
3AF42	SI	2'-2"	2								
3AF43	SI	2'-2"	2								
3AF44	SI	4'-2"	8								
3AF45	SI	7'-2"	16								
3AF46	SI	3'-2"	10								
3AF47	SI	18'-2"	12								
3AF48	SI	18'-2"	12								
3AF49	SI	4'-2"	22								
3AF50	SI	36'-2"	2								
NOTE: HEADER REINFC. SHOULD BE GASHIS REF. SHEET											
SOUTH ABUTMENT (1 REQUIRED)											
3AF51	SI	20'-0"	10								
3AF52	SI	3'-2"	116								
3AF53	SI	32'-2"	20								
3AF54	SI	18'-2"	10								
3AF55	SI	3'-2"	22								
3AF56	SI	4'-2"	22								
3AF57	SI	3'-0"	17								
3AF58	SI	4'-2"	22								
3AF59	SI	4'-2"	22								
3AF60	SI	2'-2"	17								
3AF61	SI	2'-2"	17								
3AF62	SI	7'-2"	34								
3AF63	SI	7'-2"	3								
3AF64	SI	7'-2"	3								
3AF65	SI	7'-2"	3								
3AF66	SI	24'-2"	12								
3AF67	SI	18'-2"	12								
3AF68	SI	18'-2"	12								
3AF69	SI	3'-2"	22								
3AF70	SI	3'-2"	26								
3AF71	SI	6'-2"	2								
3AF72	SI	4'-2"	8								
3AF73	SI	7'-2"	16								
3AF74	SI	3'-2"	10								
3AF75	SI	18'-2"	12								
3AF76	SI	18'-2"	12								

MARK	TYPE	LENGTH	QUANTITY TOTAL PER UNIT	DIMENSIONS							NOTES
				A	B	C	D	E	F	G	
DECK (1 REQUIRED)											
11P17	SI	8'-2"	84								
11P18	SI	3'-2"	72								
11P19	SI	21'-0"	72								
11P20	SI	3'-2"	172								
11P21	SI	11'-6"	8								
11P22	SI	8'-2"	16								
11P23	SI	10'-2"	24								
11P24	SI	12'-2"	24								
11P25	SI	12'-2"	24								
11P26	SI	21'-0"	72								
11P27	SI	6'-2"	8								
11P28	SI	21'-0"	72								
11P29	SI	16'-0"	18								
11P30	SI	22'-0"	4								
11P31	SI	6'-2"	4								
11P32	SI	18'-2"	4								
11P33	SI	18'-2"	4								
11P34	SI	18'-2"	4								
11P35	SI	18'-2"	4								
11P36	SI	15'-2"	4								
11P37	SI	15'-2"	4								
11P38	SI	18'-2"	4								
11P39	SI	18'-2"	4								
11P40	SI	3'-2"	80								
11P41	SI	12'-2"	27								
SLAB - SPANS 1 & 2 (2 REQUIRED)											
3SL1	SI	38'-2"	257								
3SL2	SI	17'-8"	420								
3SL3	SI	34'-10"	420								
3SL4	SI	22'-6"	420								
3SL5	SI	37'-10"	420								
3SL6	SI	4'-2"	420								
3SL7	SI	38'-2"	24								



Note: All bar dimensions are out to out.

REVISIONS

1. HEADER REINFC. SHOULD BE GASHIS

BRIDGE NO. 4-I

RELOCATED C.R. NO. 9 OVER EXPRESSWAY

BAR LIST

in Charge of *F. Bolter*
 Checked by _____
 Drawn by _____
 Detail by _____
 Detail by _____

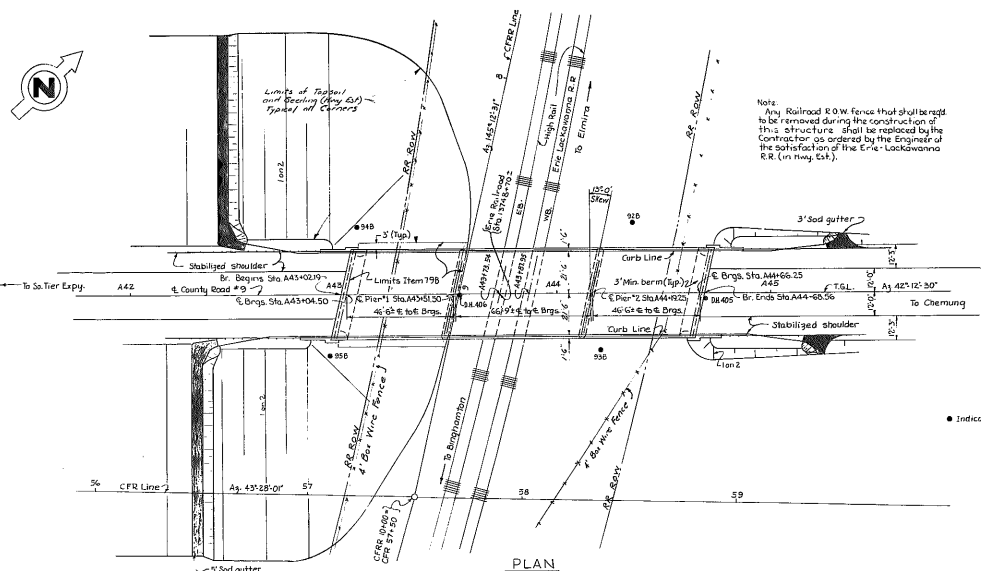
Prepared and recommended by
 11-0-0000000000
 GOODENO & ODEA

Date 4/1/67
 Consulting Engineers

DWG. NO.	SCALE	DATE	GOODENO & ODEA CONSULTING ENGINEERS
14 of 14	1/2" = 1'-0"	4/1/67	

DIST. NO.	STATE	FEDERAL AID PROJECT NO.	SHEET NO.	TOTAL SHEETS
	NEW YORK	APD-221(21)	175	199

SOUTHERN TIER HIGHWAY, SECTION 4R
 LOCUST-HAVELI, COLUMBIUS COUNTY



Note: Any Railroad R.O.W. Fence that shall be required to be removed during the construction of this structure shall be replaced by the Contractor as ordered by the Engineer to the satisfaction of the Erie-Lackawanna R.R. (in they ask).

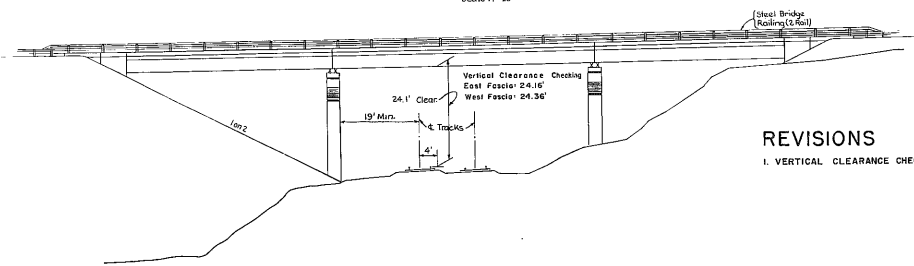


LOCATION PLAN
Scale: 1" = 1 Mile

• Indicates Savings

Notes:
 All sod gutters shown are included in Bridge Est.
 For General Notes see Dwg S-3
 For Bridge Quantities see Dwg S-2

PLAN
Scale: 1" = 20'



REVISIONS
 1. VERTICAL CLEARANCE CHECKING

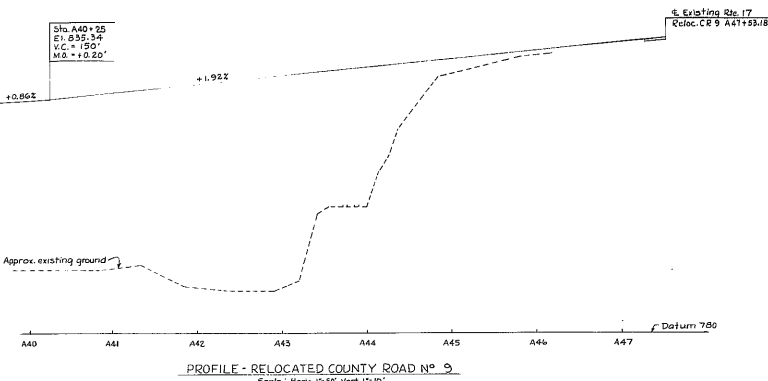
ELEVATION
Scale: 1" = 10'

DWG. NO.	TITLE
1	Plan & Elevation
2	Longitudinal Section & Profiles
3	Foundation Details
4	Pier 1 & South Abutment
5	Pier 2
6	Pier 3
7	Rolling & Steel Layouts
8	Transverse Section & Reinf. Plan
9	Common Details
10	Common Details
11	Common Details
12	Bar List

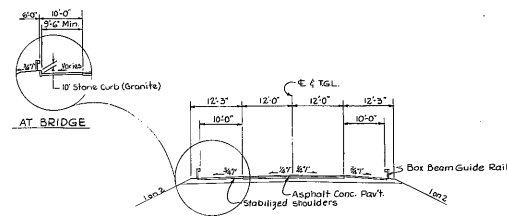
PROJECT ENGINEER: E.J. Butler
 IN CHARGE OF: M.A. Gosciniak
 DESIGNED BY: E.J. Butler
 CHECKED BY: G. J. McIlhenny
 DETAIL CHECKED BY: G. J. McIlhenny

BRIDGE NO. 8
 COUNTY ROAD 9 OVER
 ERIE-LACKAWANNA RAILROAD
 C. NB STA. A45+90.36 B. CFRR 8+86.00
 PLAN & ELEVATION
 DRAWING NO. 1 OF 12

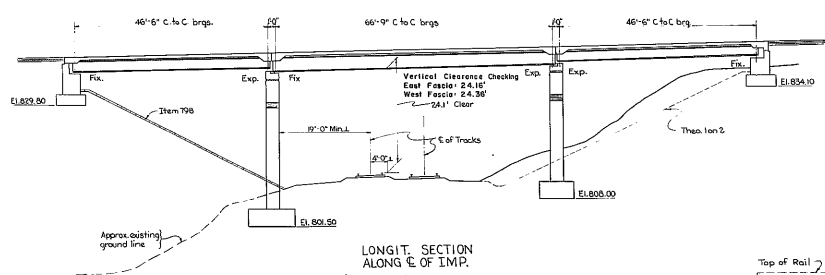
FED. RD. DIST. NO.	STATE	FEDERAL AID PROJECT NO.	SHEET NO.	TOTAL SHEETS
	NEW YORK	APD-221(21)	776R	199
SOUTHERN Tier EXPRESSWAY, SECTION 63 LONGAWANNA, TANK 1 OSWEGO COUNTY				



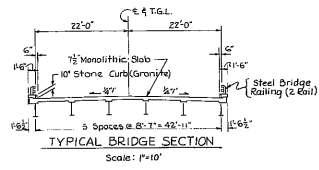
PROFILE - RELOCATED COUNTY ROAD N° 9
Scale: Horiz. 1"=50', Vert. 1"=10'



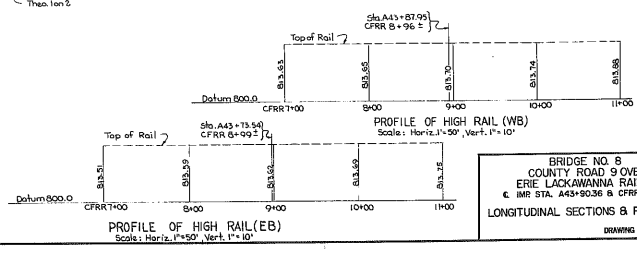
TYPICAL APPROACH SECTION C.R. N° 9
Scale: 1"=10'



LONGIT. SECTION
ALONG C. OF IMP.
Scale: 1"=10'



TYPICAL BRIDGE SECTION
Scale: 1"=10'



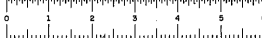
PROFILE OF HIGH RAIL (WB)
Scale: Horiz. 1"=50', Vert. 1"=10'

PROFILE OF HIGH RAIL (EB)
Scale: Horiz. 1"=50', Vert. 1"=10'

BRIDGE NO. 8
COUNTY ROAD 9 OVER
ERIE LACKAWANNA RAILROAD
C. I.M.R. STA. A43+80.36 & C.F.R.R. 8+95.00
LONGITUDINAL SECTIONS & PROFILES
DRAWING NO. 2 OF 12

PROJECT ENGINEER	S. E. P...
IN CHARGE	M. S. G...
DESIGNED BY	C. M. H. J.
DESIGN CHECKED BY	D. S...
DETAILS BY	C. M. H. J.
DETAIL CHECKED BY	C. M. H. J.

REVISIONS
1. VERTICAL CLEARANCE CHECKING



STATE	PROJECT NO.	SHEET NO.	TOTAL SHEETS
NEW YORK	APD-22(C21)	177	200

SOUTHWEST TIER EXPIRATION, SECTION 66
LORDS-BURDETT, PART 1
COUNTY

DISASSEMBLY NOTES

All soil, topsoil and unsuitable material under the substructure embankment shall be removed as specified under the General Excavation Specifications and replaced by the same item as the layer of embankment adjacent and above as shown on the plans.

All unsuitable material under the south approach embankment between Station 44+00 and 44+100 shall be removed and backfill with Item 220-B as shown on the plans or as ordered by the Engineer.

All subgrade of Selected Granular Fill, Item 220-B and selected fill (Under Foundation), Item 220-B shall be compacted to a minimum dry density of 100% of Maximum Density as defined under the provisions of the General Excavation Specifications. However, where the material contains more than 35% by weight of particles retained on the 75 mesh sieve, a minimum dry density of 95% of the Maximum Density will be required.

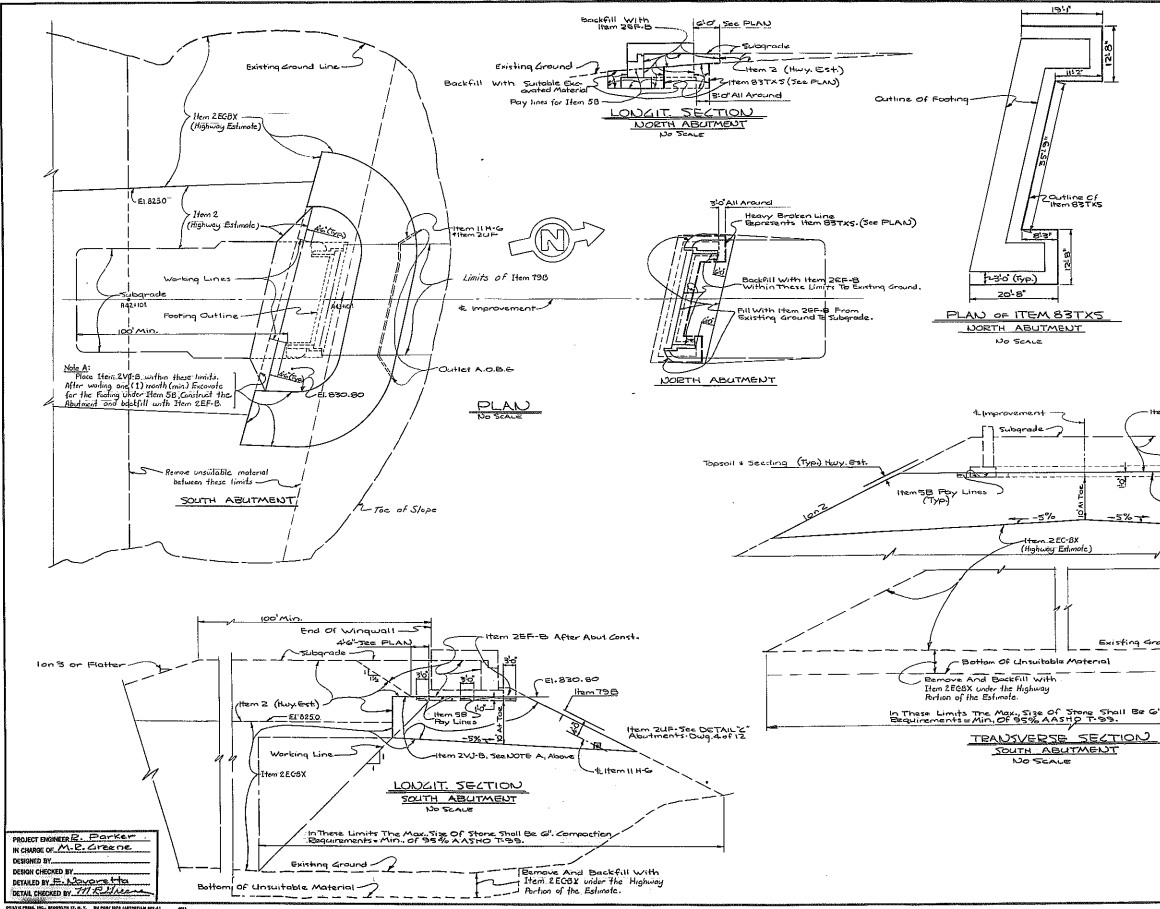
The Contractor shall place and compact all fill for this structure between the final rise of slope in accordance with the plans and specifications in a manner satisfactory to the Deputy Chief Engineer.

The embankment at the south abutment shall be built to subgrade including the area occupied by the abutment for a distance of 100 feet minimum back from the wingwall. The embankment shall be allowed to stand a minimum of 30 days or for a period of time as determined by the Deputy Chief Engineer (Design) prior to any substructure construction.

Construction of the abutment shall not be started until the completion of this waiting period.

Items 220-B and 220-C shall be placed continuously, each layer 2 and 220-C shall be placed immediately in contact, on both sides of the vertical pavement line. Bleeding or other water shall not be used to segregate the two materials.

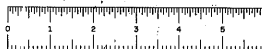
The backfill of embankment fill, Item 220-B, as shown on the structural plans, shall be completed immediately following the completion of abutments or walls.



PROJECT ENGINEER: R. Barker
IN CHARGE OF: M.E. Greene
DESIGNED BY: _____
DESIGN CHECKED BY: _____
DETAILS BY: E. J. Johnson
DETAILS CHECKED BY: 777

BRIDGE NO. 8
COUNTY ROAD 9 OVER
ERIE LACKAWANNA RAILROAD
+ 100' STA. 44+00.00 S. OF RR 49+95.00
EMBANKMENT DETAILS

DRAWING NO. 3 OF 12



FED. PROJ. NO.	STATE	FEDERAL AID PROJ. NO.	SHEET NO.	TOTAL SHEETS
	NEW YORK	APD-221(1)	178	220

SOUTHERN R.R. OVERPASS, SECTION 08
 LONGMEADOW, PART 1
 COLUMBIAN COUNTY

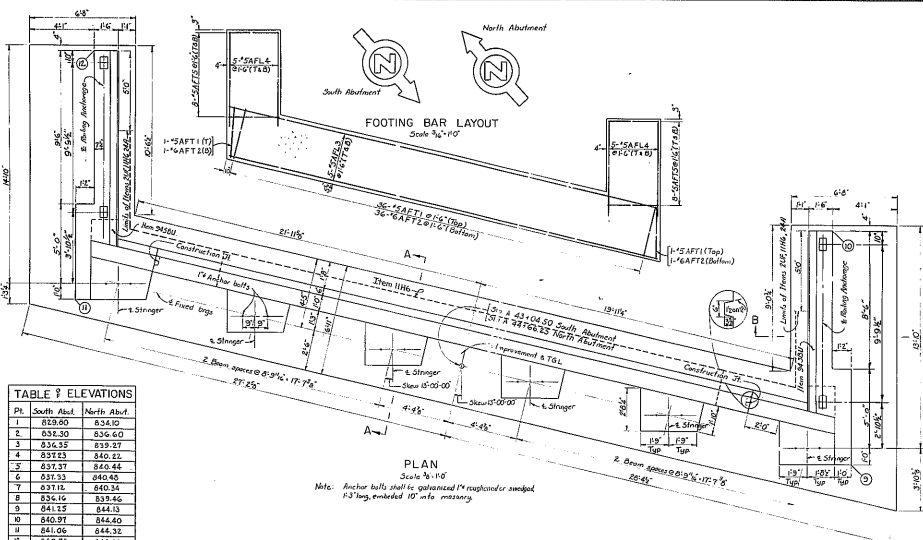
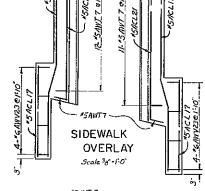
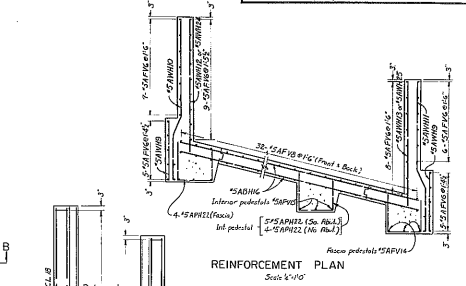


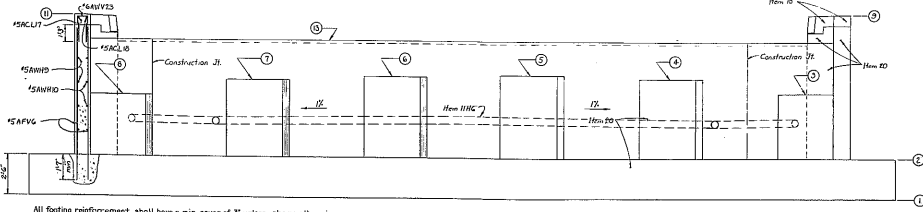
TABLE OF ELEVATIONS

PI	South Abut.	North Abut.
1	829.80	834.10
2	832.30	836.60
3	836.35	839.27
4	837.83	840.23
5	837.37	840.44
6	837.33	840.45
7	837.16	840.35
8	836.16	839.45
9	841.15	844.13
10	840.97	844.40
11	840.06	844.32
12	840.76	844.61
13	838.00	842.00

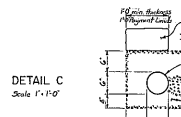
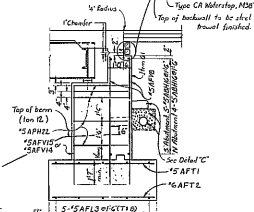
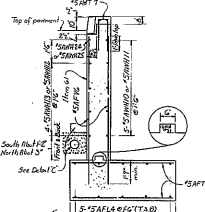
PLAN Scale 1/4"=1'-0"
 Note: Anchor bolts shall be galvanized 1/2" roughened and snaped 1/2" long, embedded 10" into masonry.



Two courses of concrete laid set in mortar. Cold to be included in concrete. Stone to be placed during the placement of slab concrete by stone or other suitable means.
 Compressed Airblast Steel Paving groutbed both sides of slab.
 Type CR Mortar, M20
 Top of subgrade to be shot & levelled.

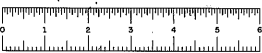


All footing reinforcement shall have a min. cover of 3" unless shown otherwise.
 All other reinforcement shall have a min. cover of 2" unless shown otherwise.
 For design purposes the foundation pressure shall not exceed 4.5 tons per sq. foot.
 For details of concrete work, joint sealing, etc., see Concrete Details.
 For notes on masonry anchors, etc., see Drawing No. 9 of 12.
 For footing spacing, see Drawing No. 7 of 12.



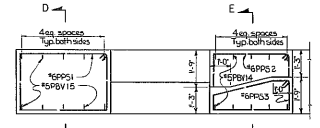
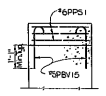
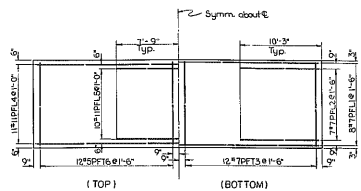
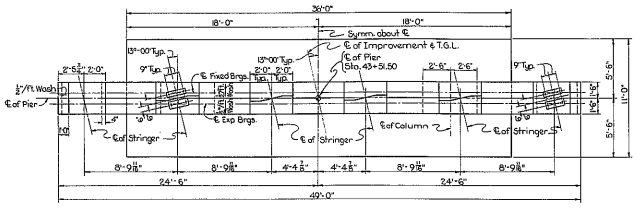
PROJECT ENGINEER: R. L. Beckwith
 IN CHARGE OF: M. R. Greene
 DESIGNED BY: G. Hall, Jr.
 DESIGN CHECKED BY: P. H. Smith
 DRAWING CHECKED BY: G. M. H. H.
 DETAILED BY: G. M. H. H.

BRIDGE NO. 8
 COUNTY ROAD NO. 9 OVER
 ERIE LACKAWANNA RAILROAD
 C. 100 STA. A43+90.36 C.F.R.R. 8+95.00
 NORTH & SOUTH ABUTMENT
 DRAWING NO. 178 OF 220

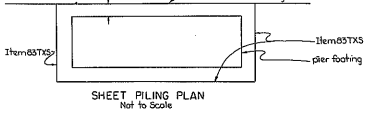
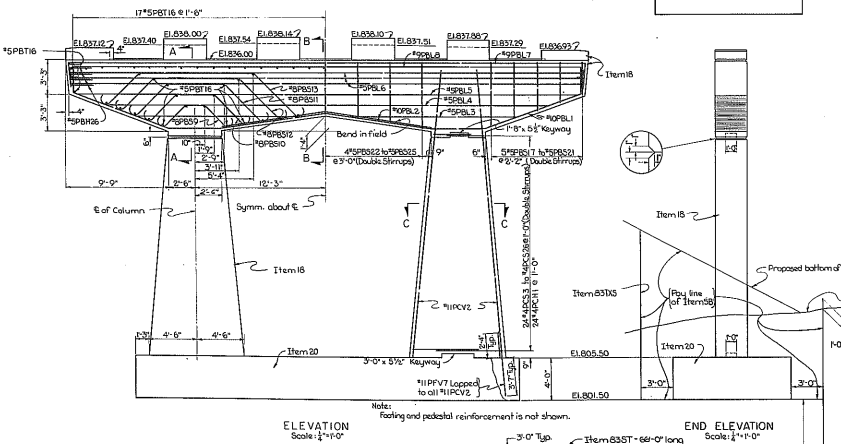
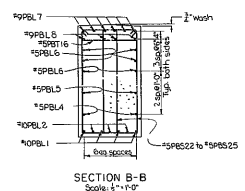
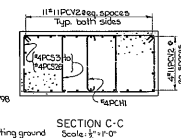


FED. PROJ. NO.	STATE	FEDERAL AID PROJECT NO.	SHEET NO.	TOTAL SHEETS
	NEW YORK	APD-271(21)	779	200

SOUTHERN TIE EXPRESSWAY, SECTION 6R
 12-MILE SECTION, PART 1
 COLUMBIAN COUNTY



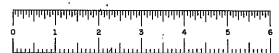
Item 63135 must be used in execution for the construction of Pier #1. The option under Item 5B will not be allowed.



Notes:
 All footing reinforcement shall have a min. cover of 3" unless otherwise noted.
 All other reinforcement shall have a min. cover of 2" unless otherwise noted.
 Anchor bolts for bearings shall be galvanized 1/4" roughened or swaged bolts and set 10" into masonry.
 For design purposes the foundation pressure does not exceed 2.0 tons/sq. ft.
 Construction of pier #1 shall not be started until the completion of the pier concrete minimum waiting period specified for the South Abutment Embankment.
 The minimum section modulus per foot and the minimum web thickness for Item 6357 shall be 14.0 in³/ft and 3/8" respectively.

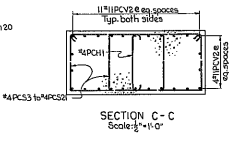
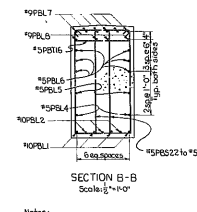
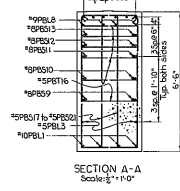
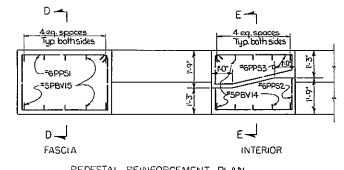
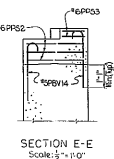
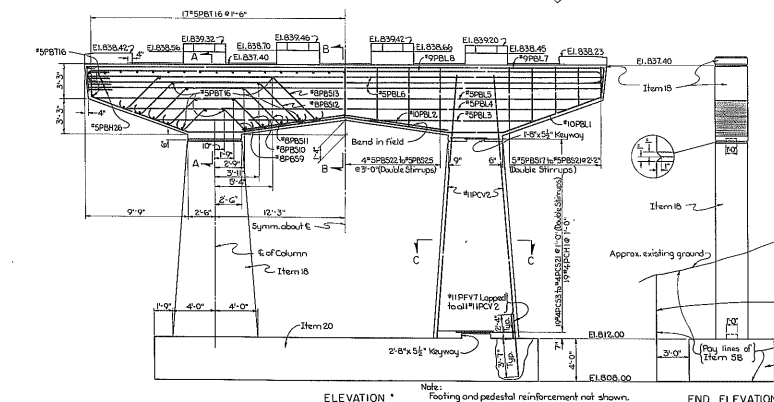
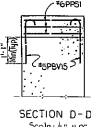
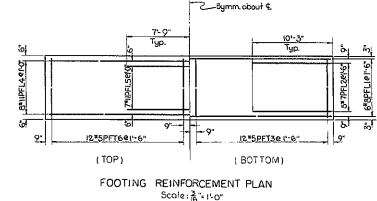
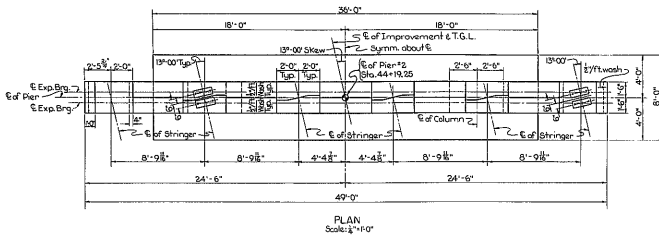
PROJECT ENGINEER: B. Buckner
 IN CHARGE OF: M. Gutzwiller
 DESIGNED BY: C. Hall, Jr.
 DESIGN CHECKED BY: A. C. Isaacs
 DETAIL BY: J. Albrecht
 SCALE CHECKED BY: J. M. Smith

BRIDGE NO. 8
 COUNTY ROAD 9 OVER
 ERIE LACKAWANNA RAILROAD
 C. MB STA. 485+63.86 & CTR 5+85.00
 PIER NO. 1
 DRAWING NO. 5 OF 12

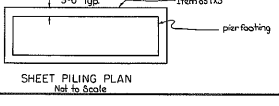


FED. RD. DIST. NO.	STATE	FEDERAL PROJECT NO.	SHEET NO.	TOTAL SHEETS
	NEW YORK	100-21(21)	180	200

SOUTHERN TIER EXPRESSWAY, SECTION 6B
LONGS-VALELLI, PART 1
OSWEGO COUNTY

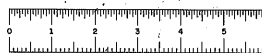


Notes:
All footing reinforcement shall have a min. cover of 3" unless otherwise shown.
All other reinforcement shall have a min. cover of 2" unless otherwise shown.
Anchor bolts for bearings shall be galvanized 1" x galvanized or welded and set 10" into masonry.
For design purposes the foundation pressure does not exceed 2 1/2 tons/sq.ft.



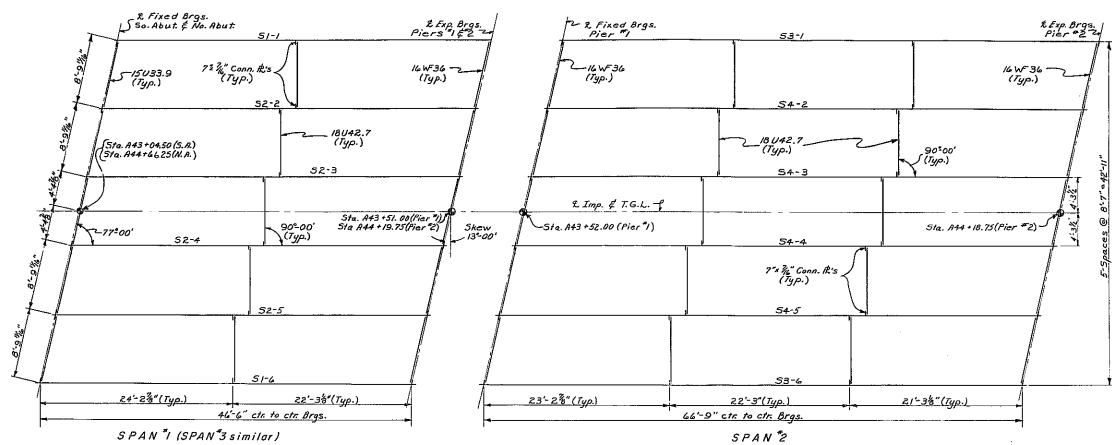
PROJECT ENGINEER: R. Parker
IN CHARGE OF: M. Greene
DESIGNED BY: C. Hall
DESIGN CHECKED BY: A. G. G. G.
DETAILED BY: J. Alvord
DETAIL CHECKED BY: D. H. Smith

BRIDGE NO. 8
COUNTY ROAD 9 OVER
ERIE LACKAWANNA RAILROAD
E. IMP. STA. A-43+90.36 B. CFRM 8+95.00
PIER NO. 2
DRAWING NO. 6 OF 12



STATE	FEDERAL PROJECT NO.	SHEET NO.	TOTAL SHEETS
NEW YORK	APD-231(2)1	181	200

SOUTHWEST TIER EXPRESSWAY, SECTION 1A
 SOUTHWEST TIER EXPRESSWAY, PART 1
 CHEMUNG COUNTY

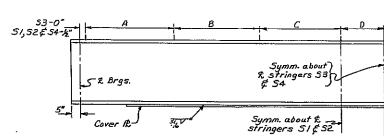


GIRDER	E. BRGS.	E. BRGS.	E. BRGS.	E. BRGS.
NO. END	STRAINER	NO. END	STRAINER	NO. END
S1-1	835.73	840.70	840.65	
S2-2	835.87	840.32	840.76	
S2-3	840.07	840.44	840.90	
S2-4	838.97	840.47	840.97	
S2-5	839.76	840.20	840.65	
S1-6	839.24	839.59	840.43	
S3-1	840.64	841.58	841.52	
S4-2	840.70	841.42	842.06	
S4-3	840.92	841.25	842.20	
S4-4	840.00	841.53	842.17	
S4-5	840.47	841.37	841.95	
S2-4	840.49	841.09	841.79	
S1-6	841.94	842.30	842.34	
S2-5	842.00	842.53	842.98	
S2-4	842.22	842.07	843.12	
S2-3	842.19	842.53	843.00	
S2-2	841.97	842.42	842.56	
S1-1	841.73	842.20	842.64	

Note: See Misc. Sheet # for Bearings.

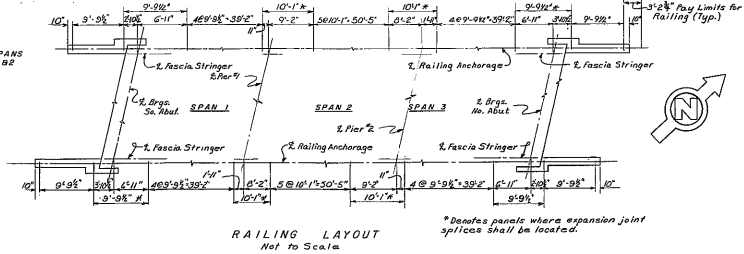
Bottom of slab elevations shown in this table are computed for this point.

STEEL LAYOUT
 Scale: 1/4" = 1'-0"



STRINGER	DISTANCE C/BRGS.	BEAM (A36)	COVER PLATE (A36)	DEFLECTIONS STEEL	CAN. BEES	STUD SHEAR CONNECTOR SPACINGS				
				STEEL	TOTAL	A	B	C	D	
S1(fascia)	46'-6"	36W735	None	006.027	033	3/4"	106	67	148	57
S1(int)	46'-6"	27W54	12" x 40"	009.066	075	3/4"	106	77	148	57
S3(fascia)	46'-5"	36W735	14" x 40"	072.006	112	1/2"	106	77	148	57
S4(int)	46'-5"	36W735	14" x 40"	002.106	130	1/2"	106	77	148	57

Note:
 Cover plate symmetrical about beam.
 *S.D.L. includes the weight of the slab, sidewalk & railing.

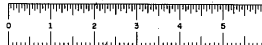


RAILING LAYOUT
 Not to Scale

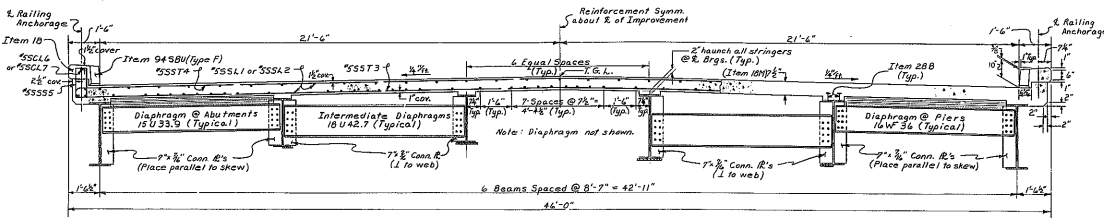
*Double panels where expansion joint splices shall be located.

PROJECT ENGINEER: R. Parker
 IN CHARGE OF: M. G. R. ...
 DESIGNED BY: G. C. ...
 DESIGN CHECKED BY: D. H. ...
 DETAIL BY: M. C. Thompson
 REVIEW CHECKED BY: G. H. ...

BRIDGE NO. 8
 COUNTY ROAD 9 OVER
 ERIE LACKAWANNA RAILROAD
 @ IMP. STA. 443+90.36 & C/P RR 0+95.00
 RAILING & STEEL LAYOUT
 DRAWING NO. 7 OF 12



REV. NO.	DATE	BY	CHKD.	DESCRIPTION
1				
2				
3				
4				
5				
6				
7				
8				
9				
10				
11				
12				
13				
14				
15				
16				
17				
18				
19				
20				
21				
22				
23				
24				
25				
26				
27				
28				
29				
30				
31				
32				
33				
34				
35				
36				
37				
38				
39				
40				
41				
42				
43				
44				
45				
46				
47				
48				
49				
50				
51				
52				
53				
54				
55				
56				
57				
58				
59				
60				
61				
62				
63				
64				
65				
66				
67				
68				
69				
70				
71				
72				
73				
74				
75				
76				
77				
78				
79				
80				
81				
82				
83				
84				
85				
86				
87				
88				
89				
90				
91				
92				
93				
94				
95				
96				
97				
98				
99				
100				



TRANSVERSE SECTION
Scale: 1/2" = 1'-0"

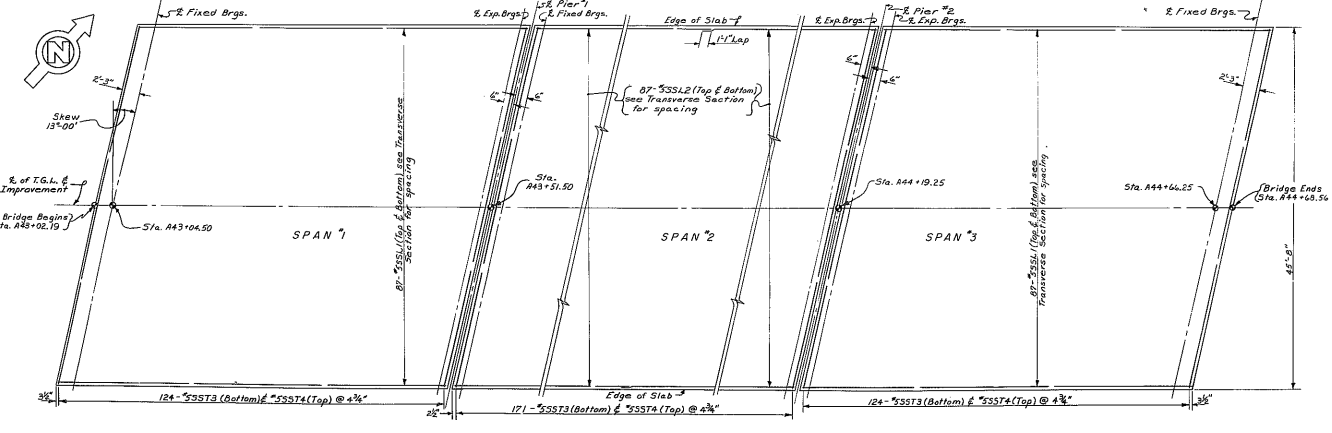
Structural Steel members which are embedded in or contact with cast or pneumatically projected concrete shall not be painted.

Machined finished sliding surfaces in contact (pins, pins or one-half pin rollers as enclosed) shall receive in the shop one coat of a hot mixture of white lead and oil as provided for in the specifications under Part II, section 5c, Painting. This shop coat of white lead and oil shall be removed immediately prior to the assembly of the member in the field. All other machined finished surfaces shall be given one shop coat of paint.

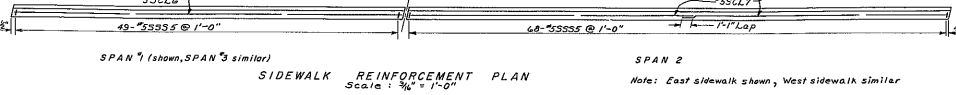
Note: Holes for 3/8" high strength bolts, plates and nuts may be cam fitted and welded substituted if Contractor so elects. When the Contractor elects to substitute welded connections for the bolted connections shown, sufficient welding shall be provided to develop the strength of the bolts that are removed.

Note: See Common Detail Drawings for Granite Curb, Railing & Railing Anchorage.

7/8" Conn. R's shall be attached to webs with continuous welds so as to develop the full strength of conn. plate as per Specifications of American Welding Society.



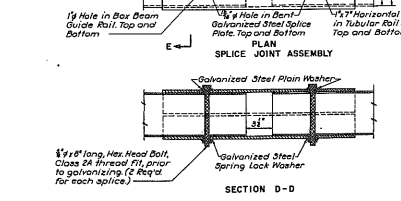
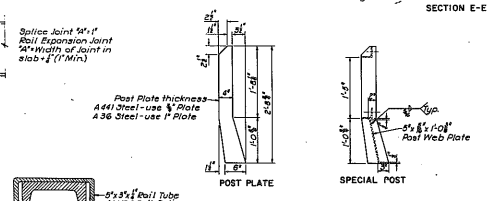
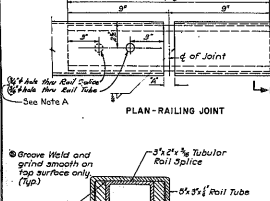
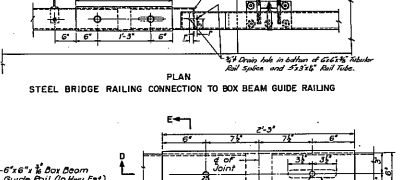
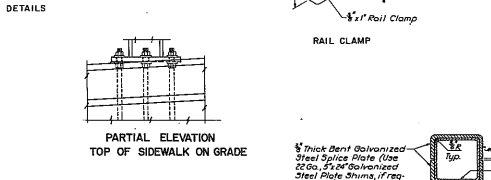
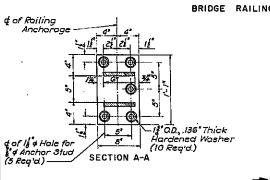
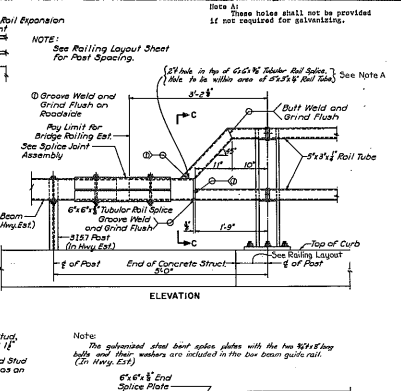
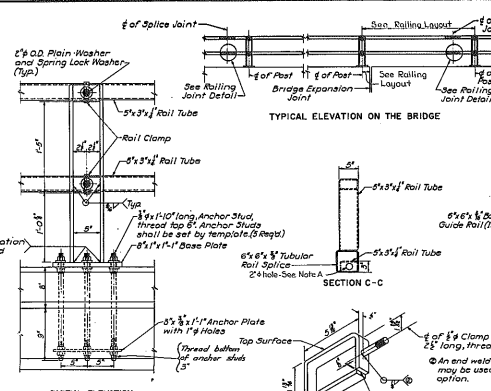
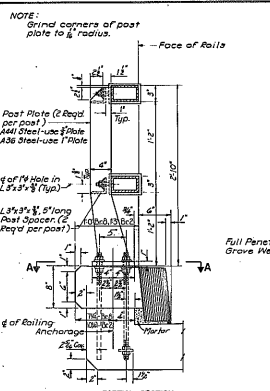
SLAB REINFORCEMENT PLAN
Not to Scale



SIDEWALK REINFORCEMENT PLAN
Scale: 3/8" = 1'-0"

PROJECT ENGINEER: R. Parker
 IN CHARGE OF: M. R. Brennan
 DESIGNED BY: C. G. Hall Jr.
 DESIGN CHECKED BY: D. H. Smith
 DETAIL BY: J. C. Thompson
 CHECKED BY: D. H. Smith

BRIDGE NO. 8
 COUNTY ROAD 9 OVER
 ERIC LACKAWANNA RAILROAD
 E. BR. STA. A43+90.36 & CRRR 8+95.00
 SUPERSTRUCTURE
 DRAWING NO. 6 OF 12



REV.	DATE	BY	CHKD.	APPROVED	SHEET NO.	TOTAL SHEETS
					3	20

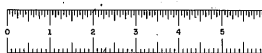
SOUTHERN TIER EXPRESSWAY, SECTION 6R
LOMAN-WAVERLY, PART I
CHUMING COUNTY

Notes:
1. All railing is to be fabricated and erected so that the rails are parallel to each other and to the parapet and so that the posts are truly vertical.
2. Since the finished railing must meet all requirements of fit, alignment, grade and verticality of post to the full satisfaction of the Engineer, it is suggested that the railing be made before any shop fabrication is performed.
3. The railing is to be perpendicular to the post unless otherwise noted. When the railing is to be placed on a prepared surface these plates may be parallel to the grade or may be perpendicular to the post and made level by the use of leveled shims.
4. Tubular steel railing will clamp assemblies including studs, nuts and washers, posts, post bases or other railing components to the box beam guide railing and any necessary shims and/or pads shall be used under the railing time.
5. Anchor studs, nuts and washers and anchor plates shall be placed under the railing.
6. After the anchor stud nuts have been placed and tightened to the satisfaction of the Engineer, the grade shall be cut off 1/8 inch above the nut seats.
7. It is impossible to obtain the absolute finish of two parts with one of these parts being a special post. Materials used in the manufacture of this railing shall conform to the requirements and/or specifications listed below:
8. Rail Tubes - ASTM Designation A500 Grade B
9. Rail Clamps and End Caps - ASTM Designation A36
10. Clamps, studs, nuts and washers - ASTM Designation A307
11. Channel Railings - ASTM Designation A36
12. Tubular Rail Splices - ASTM Designation A500 Grade B
13. Splice Plates - ASTM Designation A36
14. Post Plates - ASTM Designation A36
15. Post Bases - Same as post plate material
16. Special Posts - Same as post plate material
17. Splice bolts, nuts and washers - ASTM Designation A307
18. Anchor studs, nuts and washers - ASTM Designation A307
19. Leveling shims - Same as post plate material
20. Plate Shims - ASTM Designation A36
21. Special Posts - Same as post plate material
22. Galvanized Steel - All components of the railing including anchor studs, nuts, and washers shall be galvanized in accordance with Material Specification 703. Anchor studs shall have a Class 2A thread fit prior to galvanizing. The nut portion of the anchor studs shall be given one fluid coat of dash Orange Primer and two fluid coats of lead-free Aluminum Flat coating in the requirements of Material Specifications 703A and 703B in their order.

DETAIL OF END CAP
BRIDGE NO. 8
COUNTY ROAD 3 OVER
ERIE LACKAWANNA RAILROAD
6.500 STA. 457+50.0 TO 457+50.0
STEEL BRIDGE RAILING - TWO RAIL

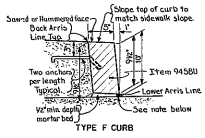
DESIGNED BY: [Signature]
CHECKED BY: [Signature]
DATE: [Date]

DRAWING NO. 9 OF 12



REQ. NO.	STATE	FORM NO.	PROJECT NO.	SHEET NO.	TOTAL SHEETS
	NEW YORK	APD-212(13)	184	200	

SOUTHERN TIER EXPRESSWAY, SECTION 6R
LOWENHARTLEY, PART 1
CATTARAUGUS COUNTY

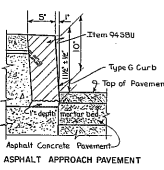


ANCHOR BAR

1/2" bar meeting requirements of M17 galvanized in accordance with M19. Coat included in price bid for curb item.

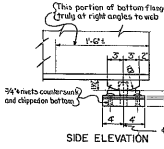
MONOLITHIC PAVEMENT GRANITE CURB ON SUPERSTRUCTURE
Not to Scale

Note: Bake out joint to a depth of 3/4" and tack pointed flash with epoxy mortar consisting of 3 parts of mortar sand to one part of M200 Epoxy Polyisofide Binder by volume.

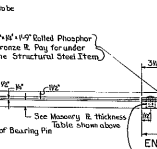


TYPE H

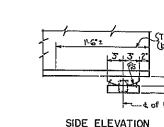
GRANITE CURB ON ABUTMENTS
Not to Scale



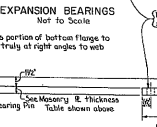
SIDE ELEVATION



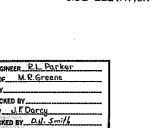
END ELEVATION



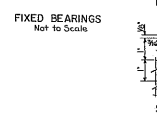
SIDE ELEVATION



END ELEVATION

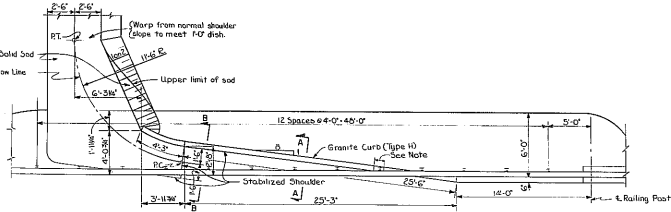


SIDE ELEVATION



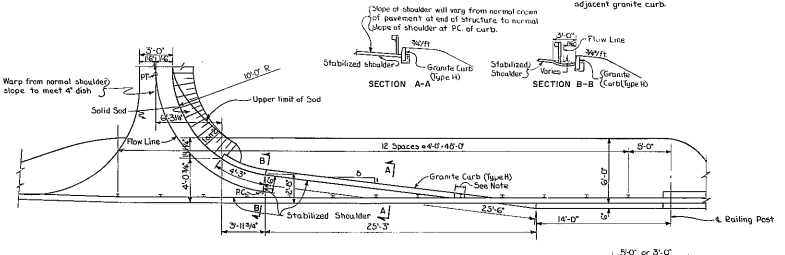
SECTION THRU DOWEL

Location	Span	Span	Span	Span	Span	Span	Span	Span	Span	Span	Span	Span	Span	Span	Span
S. Abut.	1	2	3	4	5	6	7	8	9	10	11	12	13	14	15
Pier #1	Exp.	1/2"	1/2"	1/2"	1/2"	1/2"	1/2"	1/2"	1/2"	1/2"	1/2"	1/2"	1/2"	1/2"	1/2"
Pier #2	Exp.	1/2"	1/2"	1/2"	1/2"	1/2"	1/2"	1/2"	1/2"	1/2"	1/2"	1/2"	1/2"	1/2"	1/2"
N. Abut.	1	2	3	4	5	6	7	8	9	10	11	12	13	14	15

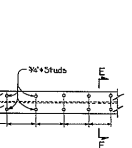


SHOULDER-FULL WIDENING-LOW END

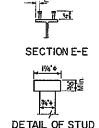
Note: 6" minimum gap in granite curb to be filled with mortar of air guide rail post has been set. This filled in portion shall be paid for at the unit price bid for the adjacent granite curb.



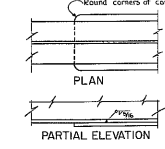
SHOULDER-FULL WIDENING-HIGH END



PARTIAL PLAN OF STUDS



DETAIL OF STUD



PARTIAL ELEVATION



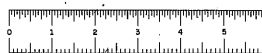
SECTION THRU SOD GUTTER

COVER PLATE WIDER THAN FLANGE
Not to Scale

Note: Special precautions must be exercised where welding across edge of flange, to avoid any possibility of undercut or nicks in edge of flange.

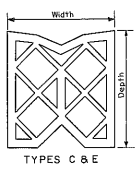
PROJECT ENGINEER: R.L. Packer
IN CHARGE OF: M.R. Greene
DESIGNED BY:
DESIGN CHECKED BY:
DETAILS CHECKED BY: Paul J. Smith

BRIDGE NO. 8
COUNTY ROAD 9 OVER
ERIE LACKAWANNA RAILROAD
c. IMP. STA. A43 + 90.36 B. CFRR 8 + 95.00
COMMON DETAILS
DRAWING NO. 10 OF 12

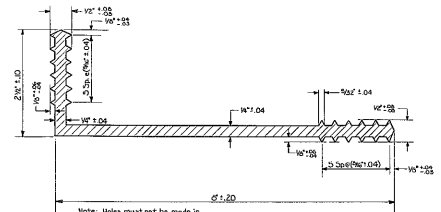
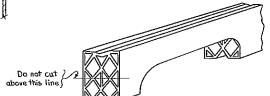
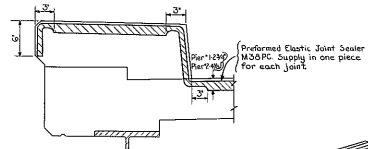


SOUTHERN TIER EXPRESSWAY, SECTION OR
LONGHAWK, PART 1
COLUMBIA COUNTY

Note: Any change in the shape or dimension of preformed elastic joint sealer must be approved by the Deputy Chief Engineer, Design.
The minimum thickness of any web shall not be less than as specified.
The average thickness of all webs shall be within the tolerances specified.



TYPES C & E

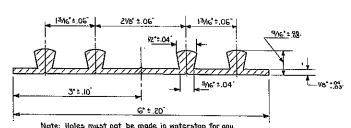


TYPE	DIMENSIONS FOR TYPES C&E			THICKNESS	
	WIDTH	DEPTH	SHELL	WEBS	
C	7 1/2"	4 1/2" ± 0.1"	1/2" ± 0.02"	3/8" ± 0.02"	1/2" ± 0.02"
E	5 1/2"	3 1/2" ± 0.1"	3/8" ± 0.02"	1/2" ± 0.02"	3/8" ± 0.02"

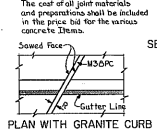
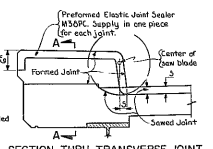
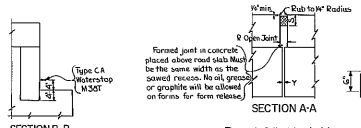
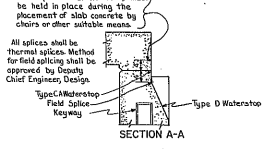
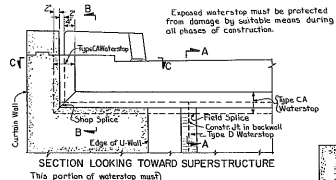
PREFORMED ELASTIC JOINT SEALER-M38PC
Not To Scale

TYPES C & E
CUTTING AND BENDING SEAL
Not to Scale

EXPANSION JOINT AT PIER MONOLITHIC PAVEMENT
Not To Scale



Note: Holes must not be made in waterstop for any purpose except as required for latching to forms. Latching to forms will only be permitted in the area between the outside ribs and the edges of waterstop.
Type D waterstop shall be light gray in color.



PROJECT ENGINEER: R.L. Parker
IN CHARGE OF: M.B. Sprague
DESIGNED BY:
DESIGN CHECKED BY:
DETAILED BY: J.E. Davy
DETAIL CHECKED BY: J.M. Smith

BRIDGE NO. 8
COUNTY ROAD 9 OVER
ERIE LACKAWANNA RAILROAD
& IMP. STA. A42+90.26 @ FCRR 8+95.00
COMMON DETAILS
DRAWING NO. 11 OF 12

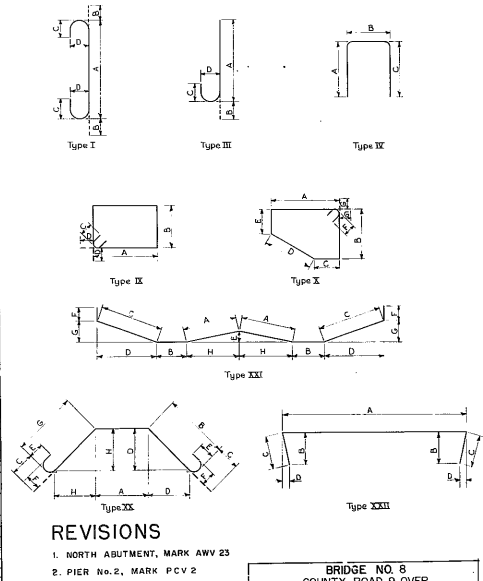
NORTH ABUTMENT table with columns: MARK, SIZE, NO., LENGTH, TYPE, A, B, C, D, E, F, G, LOCATION

SOUTH ABUTMENT table with columns: MARK, SIZE, NO., LENGTH, TYPE, A, B, C, D, E, F, G, LOCATION

SUPERSTRUCTURE table with columns: MARK, SIZE, NO., LENGTH, TYPE, A, B, C, D, E, F, G, H, I, J, K, L, M, N, O, P, Q, R, S, T, U, V, W, X, Y, Z, LOCATION

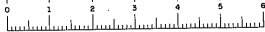
PIER 1 table with columns: MARK, SIZE, NO., LENGTH, TYPE, A, B, C, D, E, F, G, H, I, J, K, L, M, N, O, P, Q, R, S, T, U, V, W, X, Y, Z, LOCATION

PIER 2 table with columns: MARK, SIZE, NO., LENGTH, TYPE, A, B, C, D, E, F, G, H, I, J, K, L, M, N, O, P, Q, R, S, T, U, V, W, X, Y, Z, LOCATION

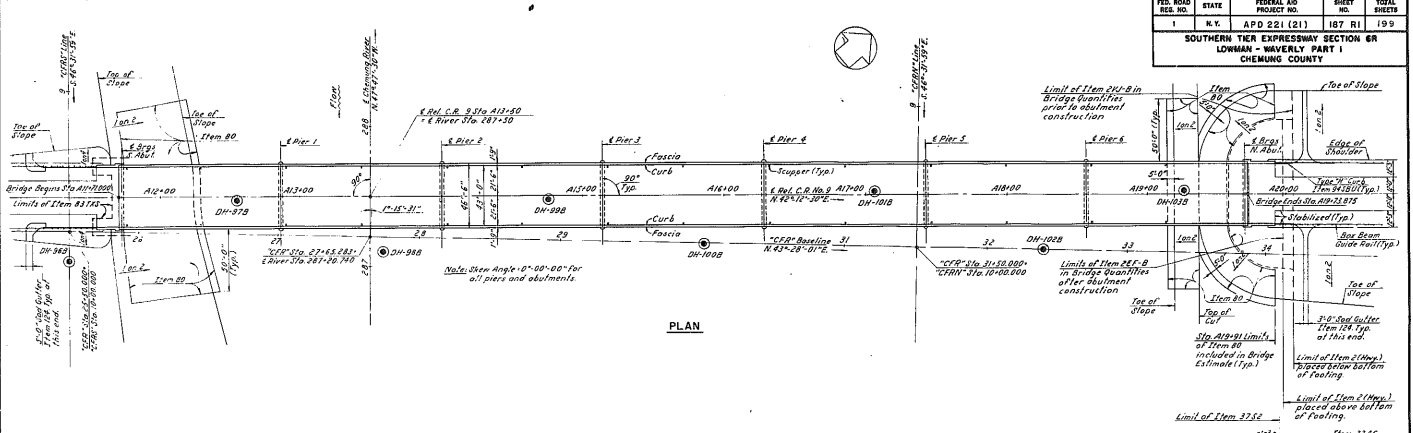


DESIGNED BY M.R. Gresser
CHECKED BY J.F. Darcy
TRACING CHECKED BY

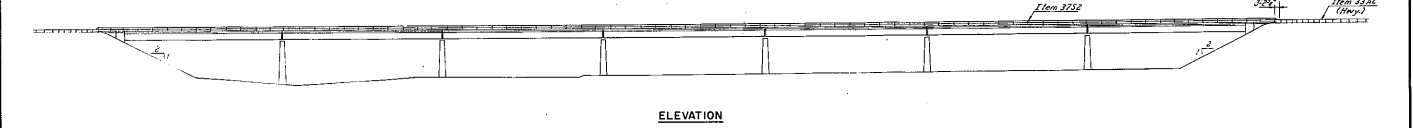
BRIDGE NO. 8
COUNTY ROAD 9 OVER
ERIE LACKAWANNA RAILROAD
G. MB. STA. A45+90.36 CRR # 95.00
BAR LIST
DWG. 12 OF 12



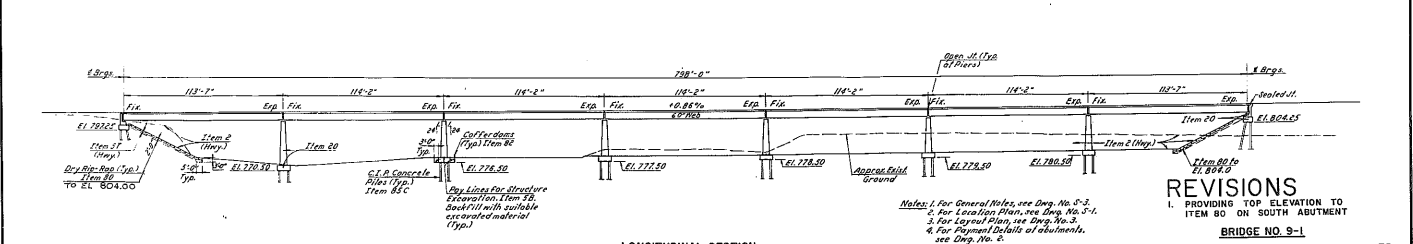
FED. ROAD DIST. NO.	STATE	FEDERAL AID PROJECT NO.	SHEET NO.	TOTAL SHEETS
1	N.Y.	APD 221 (21)	187 RI	199



PLAN



ELEVATION



LONGITUDINAL SECTION
(ALONG E. ROADWAY)

REVISIONS
1. PROVIDING TOP ELEVATION TO ITEM 80 ON SOUTH ABUTMENT

- Notes: 1. For General Notes, see Div. No. 5-2.
2. For Location Notes, see Div. No. 5-1.
3. For Layout Plans, see Div. No. 3.
4. For Payment Details of abutments, see Div. No. 5.

In Charge of S. Baizer	Date	Revision
Designed by J. Baizer		
Bridge Checked by J. Baizer		
Head Checked by J. Baizer		

RELOCATED C.R. NO. 9 OVER CHEMUNG RIVER
GENERAL PLAN AND ELEVATION

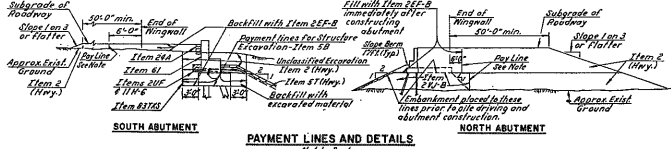
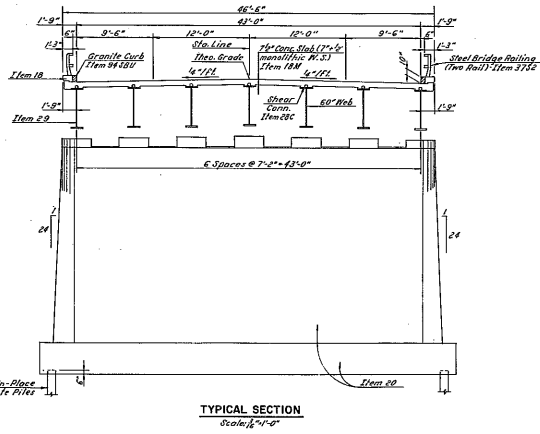
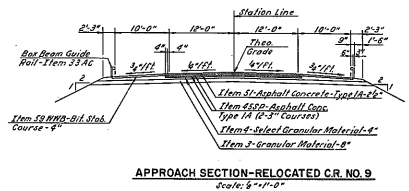
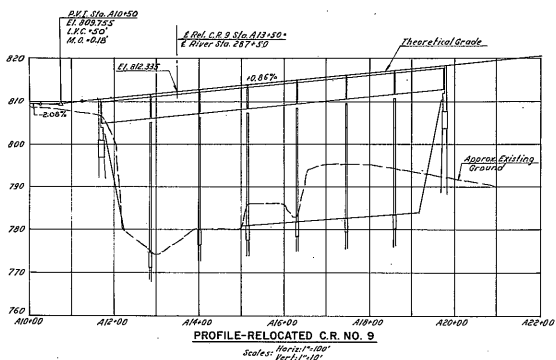
Prepared and recommended by
[Signature]
Consulting Engineer

DWG. NO.	SCALE	DATE	GOODING & OZGA CONSULTING ENGINEERS
1 of 13	1" = 30'	11/16	



FED. ROAD DIST. NO.	STATE	FEDERAL AID PROJECT NO.	SHEET NO.	TOTAL SHEETS
1	N.Y.	APD-221(11)	188	200

SOUTHERN TIER EXPRESSWAY SECTION 6R
LOWMAN - WAVERLY PART I
CHEMUNG COUNTY

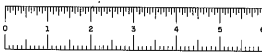


Note:
Items 24, 25, 26 and Items 27 & 28 shall be placed simultaneously, in contact on both sides of the vertical payment line. Stealing or other means shall not be used to separate the two materials.

In Charge of C. B. [Signature]	Date	Station
Designed by [Signature]		
Checked by [Signature]		
Drawn by [Signature]		
Field Checked by [Signature]		

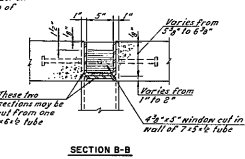
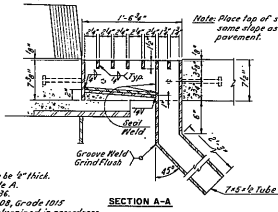
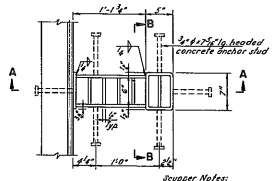
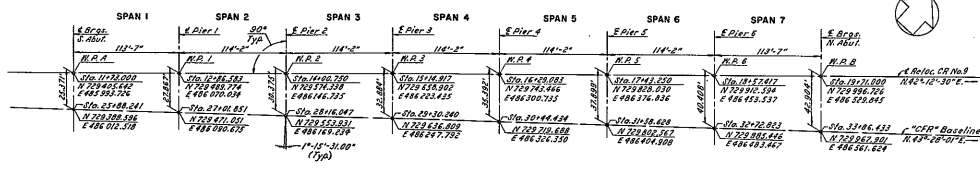
BRIDGE NO. 9-1
RELOCATED C.R. NO. 9 OVER CHEMUNG RIVER
SECTIONS AND PROFILES

Prepared and recommended by [Signature]	Date	DIV.	NO.	SCALE	DATE	GODDARD & O'NEAL
Checked by [Signature]		2 of 19	188	As shown	4/1/47	CONSULTING ENGINEERS

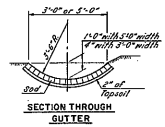
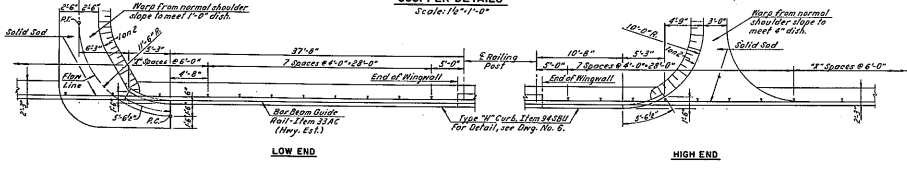


FED. ROAD DIST. NO.	STATE	FEDERAL AID PROJECT NO.	SHEET NO.	TOTAL SHEETS
1	N.Y.	APD-221(2)7	189	200

SOUTHERN TIER EXPRESSWAY SECTION 6R
LOWMAN - WAVERLY PART I
CHEMUNG COUNTY



SCUPPER DETAILS
Scale: 1/4"=1'-0"



DRAINAGE DETAILS AT ENDS OF BRIDGE
Scale: 1/4"=1'-0"

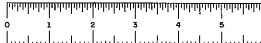
By	Date	Revised

BRIDGE NO. 9-1
RELOCATED C.R. NO. 9 OVER CHEMUNG RIVER
LAYOUT PLAN AND DRAINAGE DETAILS

Prepared and recommended by: *[Signature]*
GOODMAN & ODEA

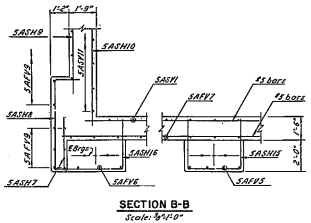
Date: 4/14/47
Consulting Engineer

DWG. NO.	SCALE	DATE	ENGINEER
3 of 12	As shown	4/14/47	GOODMAN & ODEA CONSULTING ENGINEERS

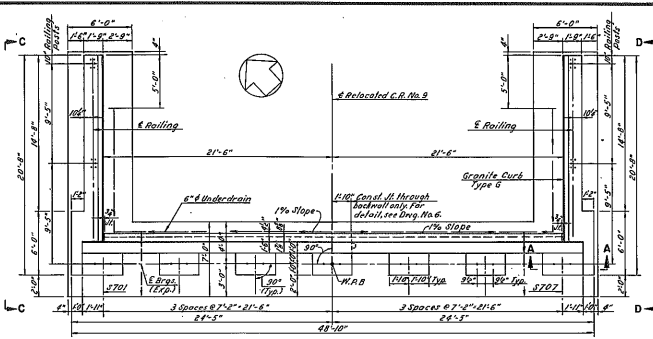


FED. ROAD DIST. NO.	STATE	FEDERAL AID PROJECT NO.	SHEET NO.	TOTAL SHEETS
1	N.Y.	ARD-251(G)1	190	200

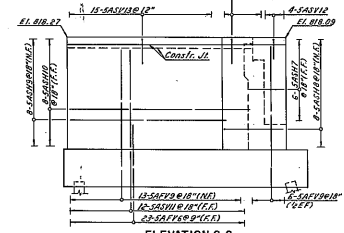
SOUTHERN TIER EXPRESSWAY SECTION, OR
LOWMAN - WAVERLY PART I
CHEMUNG COUNTY



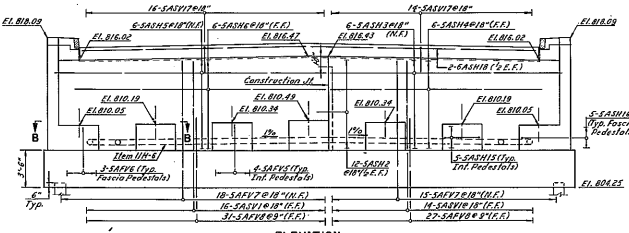
SECTION B-B
Scale: 3/4\"/>



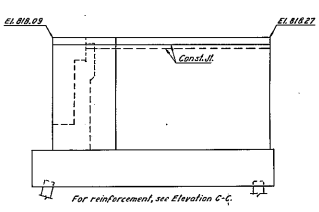
PLAN



ELEVATION C-C
Scale: 3/4\"/>

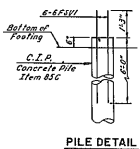


ELEVATION

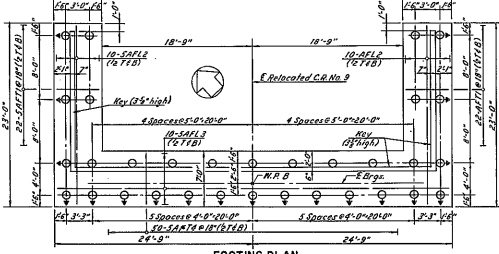


ELEVATION D-D

Note: Piles to be filled with Class A concrete. Cast to be included in Item 87C. Reinforcing to be paid for under Item 88.



PILE DETAIL
Scale: 3/4\"/>



FOOTING PLAN
Scale: 1 1/2\"/>

REFERENCES:

1. For Bar Size, see Div. No. 13.
2. For Walling Details, see Div. No. 12.
3. For Abutment Spill and Boring Details, see Div. No. 8.
4. For Abutment Details and Sections, see Div. No. 6.
5. For Section A-A, see Div. No. 5.
6. For Layout Plan, see Div. No. 2.

PILE NOTES:

1. All piles to be C.I.P. Concrete Piles.
2. 0. Shows vertical pile.
3. 0. Shows pile battered 1 on 6 in direction of arrow.
4. For design purposes the pile length does not exceed 35 tons per pile.
5. Piles to be driven to a tip elevation no higher than EL. 773.75.
6. Estimated length of piles is 30 Feet.

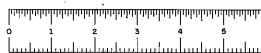
In Charge	Date	Remarks

Prepared and recommended

 Consulting Engineers

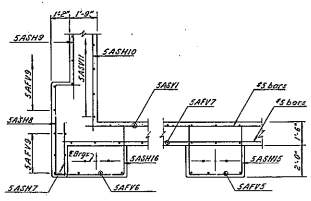
Date: 4/16/47
 G. J. O'Dea
 Consulting Engineers

BRIDGE NO. 9-1			
RELOCATED C.R. NO. 9 OVER CHEMUNG RIVER			
NORTH ABUTMENT			
DWG. NO.	SCALE	DATE	GOODING & O'DEA CONSULTING ENGINEERS
# of 10	1/4\"/>		

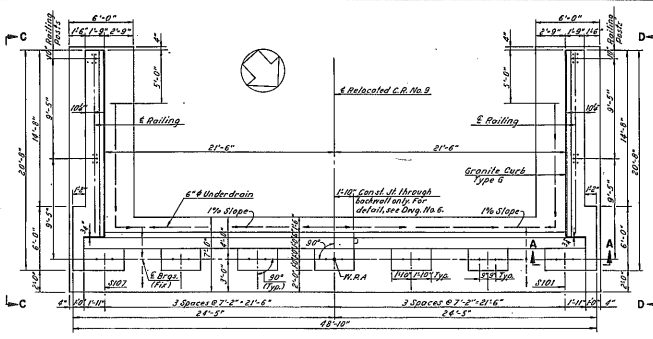


FED. ROAD DIST. NO.	STATE	FEDERAL AID PROJECT NO.	SHEET NO.	TOTAL SHEETS
1	N.Y.	APD-221(21)	191	200

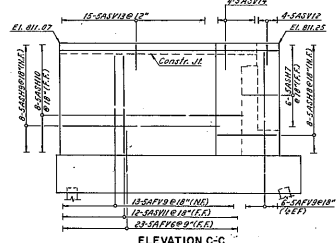
SOUTHERN TIER EXPRESSWAY SECTION 6R
LOWMAN - WAVERLY PART I
CHEMUNG COUNTY



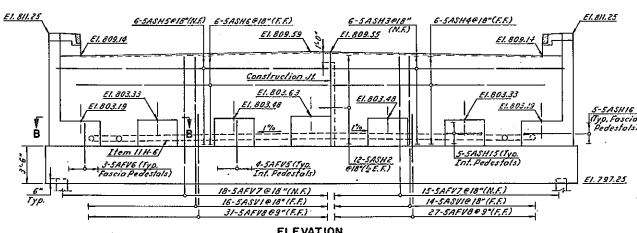
SECTION B-B
Scale: 1/4"=1'-0"



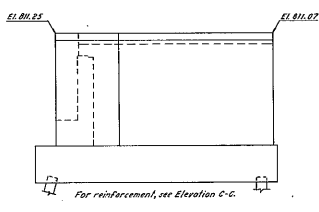
PLAN



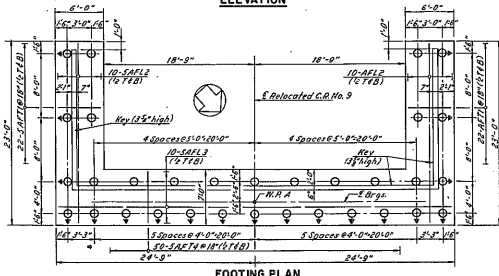
ELEVATION C-C



ELEVATION



ELEVATION D-D



FOOTING PLAN
Scale: 1/4"=1'-0"

- REFERENCES:**
- For Bar List, see Det. No. 12.
 - For Rebar Details, see Det. No. 12.
 - For Anchor Bolt and Spacing Details, see Det. No. 8.
 - For Abutment Details and Sections, see Det. No. 6.
 - For Section A-A, see Det. No. 6.
 - For Pile Detail, see Det. No. 4.
 - For Layout Plan, see Det. No. 2.
- PILE NOTES:**
- All piles to be C. R. Concrete Piles.
 - Q. Barbed steel pipe piles.
 - On. Barbed steel pipe piles to be in direction of arrow.
 - For design purposes the pile load shall not exceed 12 tons per pile.
 - Piles to be driven to a tip elevation no higher than EL. 763.00.
 - Estimated length of piles is 40 Feet.

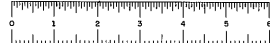
By	Date	Section
Designed by <i>F. Bolton</i>		
Checked by <i>J. J. ...</i>		
Approved by <i>J. J. ...</i>		
Field Checked by <i>J. J. ...</i>		

BRIDGE NO. 9-1
RELOCATED C.R. NO. 9 OVER CHEMUNG RIVER
SOUTH ABUTMENT

Prepared and recommended by *W. J. ...*
WOODRUM & OZGA
Consulting Engineers

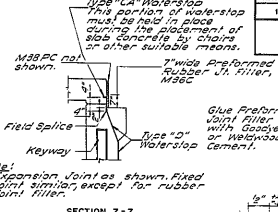
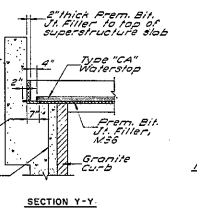
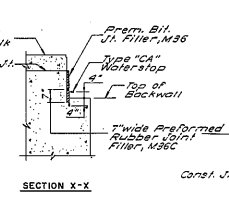
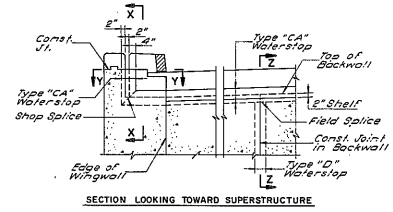
DATE: 5-27-12
SCALE: 1/4"=1'-0"
SHEET: 191 OF 200

GOODRICK & OZGA
CONSULTING ENGINEERS

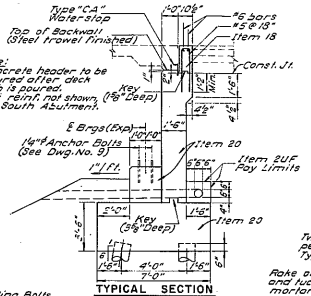
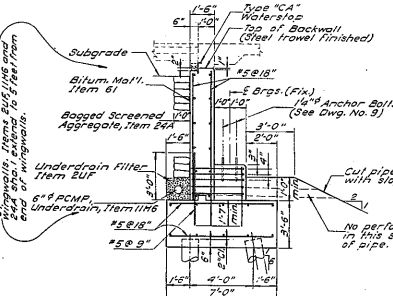


FED. ROAD DIST. NO.	STATE	FEDERAL AID PROJECT NO.	SHEET NO.	TOTAL SHEETS
1	N.Y.	APD-231(21)	192	200

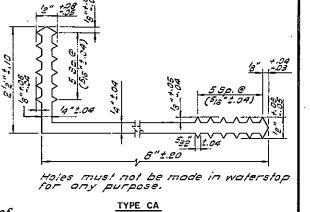
SOUTHERN TIER EXPRESSWAY SECTION 6R
LOWMAN - WAVERLY PART I
CHEMUNG COUNTY



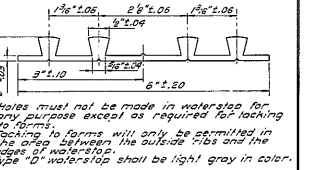
INSTALLATION OF WATERSTOPS
No Scale



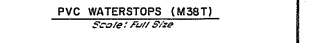
Note: All splices shall be thermal splices. Method for field splicing shall be approved by Deputy Chief Engineer. Expanded waterstop must be protected from damage by suitable means during all phases of construction.



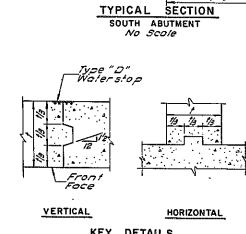
TYPE CA
Holes must not be made in waterstop for any purpose.



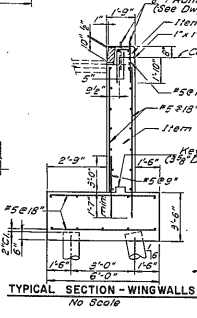
TYPE G WINGWALLS
Holes must not be made in waterstop for any purpose except as required for locking to forms. Locking to forms will only be permitted in the area between the outside ribs and the edge of waterstop. Type 'D' waterstop shall be light gray in color.



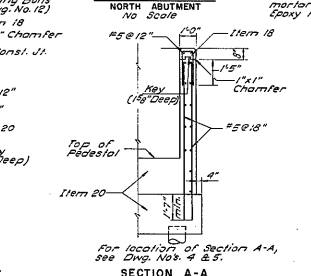
TYPE D PVC WATERSTOPS (M38T)
Scale: Full size



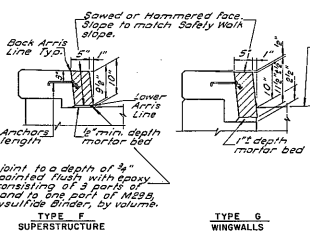
KEY DETAILS
No Scale



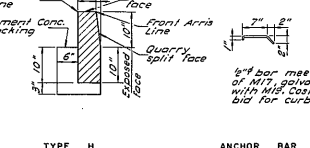
TYPICAL SECTION - WINGWALLS
No Scale



SECTION A-A
No Scale
Note: All reinforcement in abutment and wingwall sections to be #5 bars unless otherwise noted.



TYPE E SUPERSTRUCTURE
Holes must not be made in waterstop for any purpose except as required for locking to forms. Locking to forms will only be permitted in the area between the outside ribs and the edge of waterstop. Type 'D' waterstop shall be light gray in color.



TYPE H APPROACHES
ANCHOR BAR

TYPICAL CURB DETAILS
Scale: 1/2" = 1'-0"

In Charge of: *F. Bollen*
Designed by: *A. M. G. G. G.*
Engine Drawing by: *A. M. G. G. G.*
Checked by: *A. M. G. G. G.*
Head Checked by: *A. M. G. G. G.*

Rev.	Description

BRIDGE NO. 9-1
RELOCATED C.R. NO. 9 OVER CHEMUNG RIVER
ABUTMENT DETAILS

Prepared and recommended by: *A. M. G. G. G.*
GOODKIND & O'DEA
Consulting Engineers

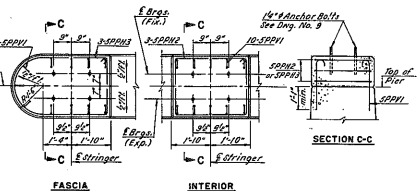
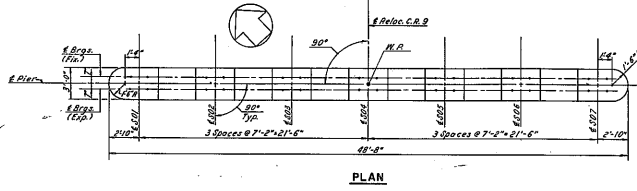
Drawn by: *A. M. G. G. G.*
Consulting Engineer

DWS.	NO.	SCALE	DATE	GOODKIND & O'DEA CONSULTING ENGINEERS
6 OF 12		Shown	4/17	

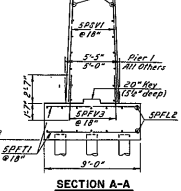
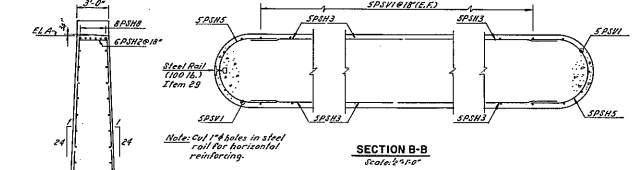
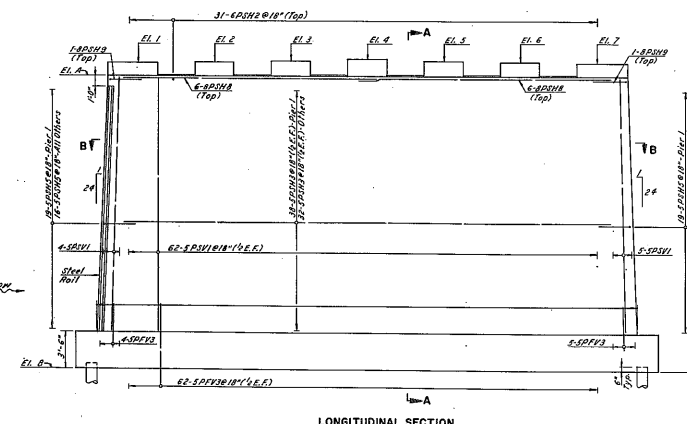


FED. ROAD DIST. NO.	STATE	FEDERAL AID PROJECT NO.	SHEET NO.	TOTAL SHEETS
1	N.Y.	APD-221(21)	193	200

SOUTHERN Tier EXPRESSWAY SECTION 6R
LOWMAN - WAVERLY PART I
CHEMUNG COUNTY

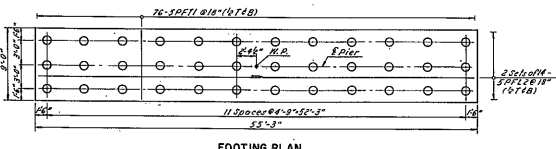


PEDESTAL DETAILS
Scale: 4"=1'-0"



- PILE NOTES:**
1. All piles are to be C. I. R. Concrete Piles
 2. For design purposes the pile load does not exceed 35 tons per pile.
 3. All piles to be driven to a minimum of 10 feet below bottom of footing.
 4. All piles to be vertical.

PILE NO.	1	2	3	4	5	6	7	EL. 74'	EL. 78'	UNFINISHED PILE LENGTH
1	604.10	604.30	604.45	604.60	604.75	604.90	605.05	605.20	605.35	77.50
2	604.14	604.34	604.49	604.64	604.79	604.94	605.09	605.24	605.39	77.50
3	604.18	604.38	604.53	604.68	604.83	604.98	605.13	605.28	605.43	77.50
4	604.22	604.42	604.57	604.72	604.87	605.02	605.17	605.32	605.47	77.50
5	604.26	604.46	604.61	604.76	604.91	605.06	605.21	605.36	605.51	77.50
6	604.30	604.50	604.65	604.80	604.95	605.10	605.25	605.40	605.55	77.50



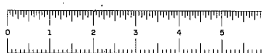
- REFERENCES:**
1. For Section 1, see Ord. No. 13.
 2. For Pile Details, see Ord. No. 4.
 3. For Layout Plan, see Ord. No. 3.

In Charge of S. B. Allen
Designed by J. E. McLaughlin
Bridge Planning by J. E. McLaughlin
Checked by J. M. McLaughlin
Initial Checked by J. E. McLaughlin

Prepared and recommended by
WOODRUFF & O'DEA
Consulting Engineers

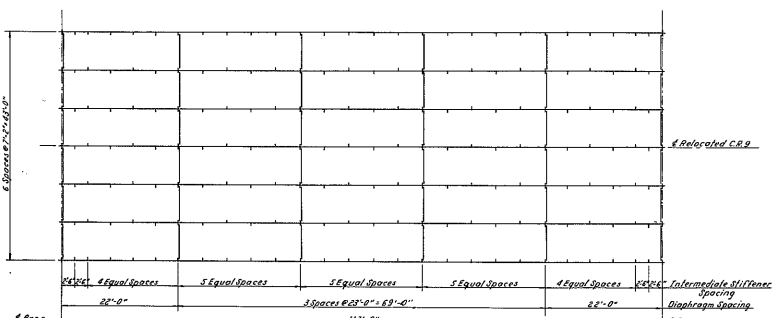
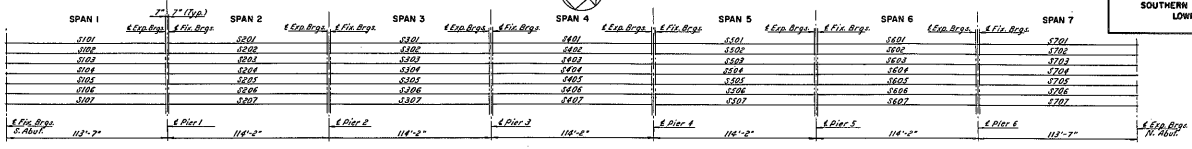
BRIDGE NO. 9-1
RELOCATED C.R. NO. 9 OVER CHEMUNG RIVER
PIERS

DRW. NO.	SCALE	DATE	WOODRUFF & O'DEA CONSULTING ENGINEERS
70712	1/4"=1'-0"	4/1/17	



FED. ROAD DIST. NO.	STATE	FEDERAL AID PROJECT NO.	SHEET NO.	TOTAL SHEETS
1	N.Y.	APD-221(13)	109	209

SOUTHERN TIER EXPRESSWAY SECTION BR
LOWMAN - WAVERLY PART I
CHEMUNG COUNTY



BOTTOM OF SLAB ELEVATIONS

MARK	A	B	C	MARK	A	B	C
S101	808.74	810.23	810.77	S301	813.67	814.13	814.64
S102	809.89	810.38	810.86	S302	813.82	814.30	814.73
S103	810.04	810.52	811.01	S303	813.97	814.45	814.94
S104	810.19	810.67	811.16	S304	814.12	814.60	815.09
S105	810.34	810.83	811.31	S305	814.27	814.75	815.24
S106	809.89	810.38	810.86	S306	813.92	814.40	814.79
S107	809.74	810.23	810.77	S307	813.67	814.13	814.64
S201	810.72	811.21	811.69	S401	814.65	815.16	815.64
S202	810.87	811.36	811.84	S402	814.80	815.29	815.77
S203	811.02	811.51	811.99	S403	814.95	815.43	815.92
S204	811.17	811.66	812.14	S404	815.10	815.58	816.07
S205	811.32	811.81	812.29	S405	815.25	815.73	816.21
S206	810.87	811.36	811.84	S406	814.80	815.29	815.77
S207	810.72	811.21	811.69	S407	814.65	815.16	815.64
S301	811.30	811.79	812.28	S101	812.63	813.12	813.60
S302	811.45	811.94	812.43	S102	812.78	813.27	813.75
S303	811.60	812.09	812.58	S103	812.93	813.42	813.90
S304	811.75	812.24	812.73	S104	813.08	813.57	814.05
S305	811.90	812.39	812.88	S105	813.23	813.72	814.20
S306	811.55	812.04	812.53	S106	812.88	813.37	813.85
S307	811.70	812.19	812.68	S107	812.63	813.12	813.60
S401	812.63	813.12	813.60				
S402	812.78	813.27	813.75				
S403	812.93	813.42	813.90				
S404	813.08	813.57	814.05				
S405	813.23	813.72	814.20				
S406	812.88	813.37	813.85				
S407	812.63	813.12	813.60				

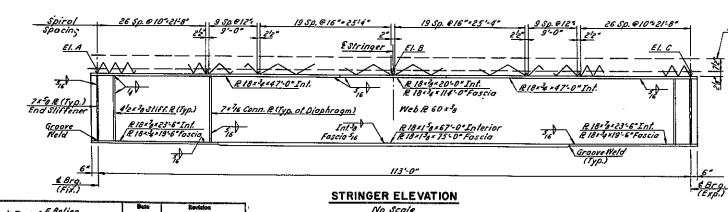
CAMBER

STRINGER	STEEL	TOTAL
	D.L.	
Interior	1/2"	1/2"
Exterior	1/2"	1/2"

Vertical Curve Camber = 0"
Camber measured along stringer

NOTES:
 Intermediate stiffeners for interior stringers shall be staggered on each side of the web.
 Intermediate stiffeners for fascia stringers shall be placed on the inside face of the web.
 See General Notes for methods of connecting stiffeners.
 Bottom Planges to be cut to 1/2" width of bearing - see Detail, Dwg. No. 2.

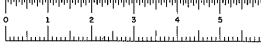
REFERENCES:
 1. For General Notes, see Dwg. No. 0-3.
 2. For Steel Details, see Dwg. No. 3.
 3. For Layout Plan, see Dwg. No. 3.



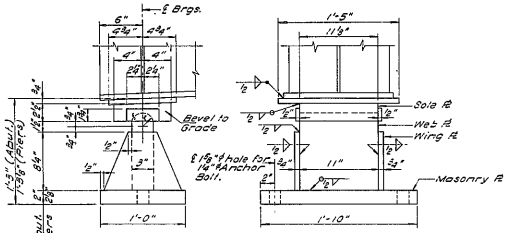
In Charge of Design	Date	Revised
Designed by: A. J. ...		
Check by: J. S. ...		
Steel Detail by: J. S. ...		

BRIDGE NO. 9-1
RELOCATED C.R. NO. 9 OVER CHEMUNG RIVER

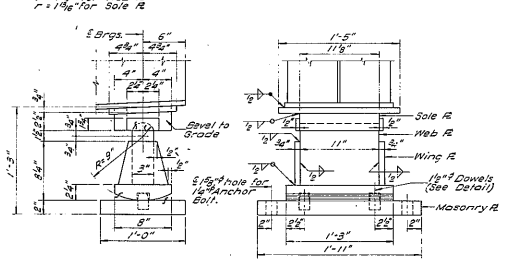
Prepared and recommended by: **WOODKIND & O'DEA CONSULTING ENGINEERS**
 Date: 4/1/57
 Checked by: **WOODKIND & O'DEA CONSULTING ENGINEERS**
 Scale: 8 of 10
 SHEET: 109
 DATE: 4/1/57
 PROJECT: SOUTHERN TIER EXPRESSWAY SECTION BR, LOWMAN - WAVERLY PART I, CHEMUNG COUNTY



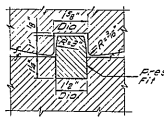
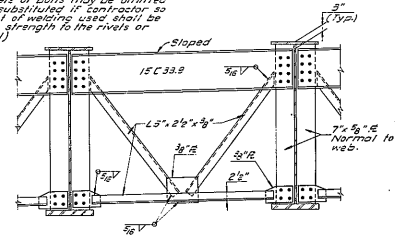
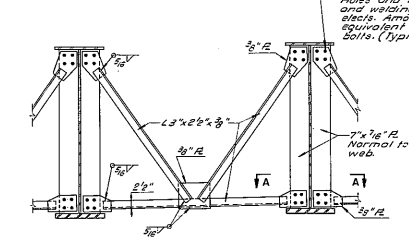
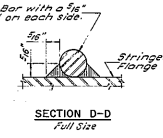
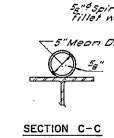
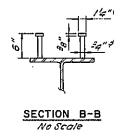
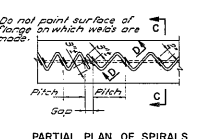
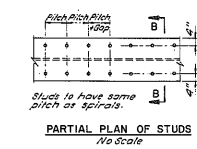
FED. ROAD DIST. NO.	STATE	FEDERAL AID PROJECT NO.	SHEET NO.	TOTAL SHEETS
1	N.Y.	APD-231(21)	125	200
SOUTHERN TIER EXPRESSWAY SECTION GR LOWMAN - WAVERLY PART I CHEMUNG COUNTY				



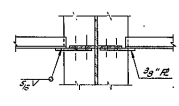
FIXED BEARING
Scale: 2 ^{1/4} 1 0



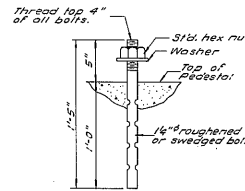
EXPANSION BEARING
Scale: 2 ^{1/4} 1 0



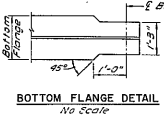
DOWEL DETAIL
Scale: Half Size



SECTION A-A
Scale: 1 ^{1/4} 1 0



ANCHOR BOLT DETAIL
No Scale



BOTTOM FLANGE DETAIL
No Scale

References: For Framing Plan, see Dwg. No. 8.

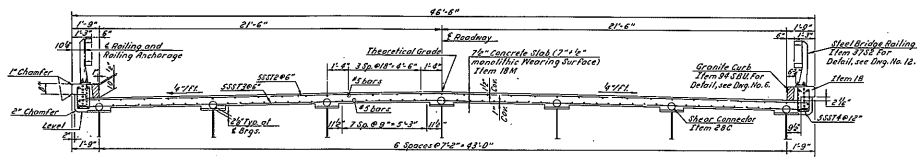
BRIDGE NO. 9-1
RELOCATED C.R. NO. 9 OVER CHEMUNG RIVER
STEEL DETAILS

In Charge	Checked by	Reviewed by
F. BOLLEN	Z. BOLLEN	

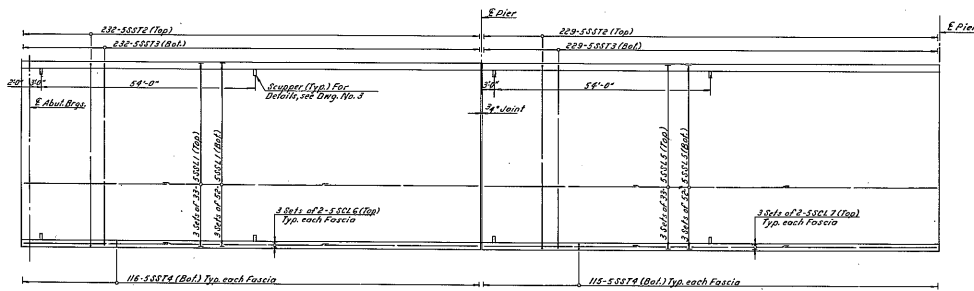
Prepared and recommended <i>(Signature)</i> GOODRIND & ODEA	Date: 4/1/49	SWG. NO. 2 of 12	SCALE 1/8" = 1'	DATE 4/1/49	GOODRIND & ODEA CONSULTING ENGINEERS
---	--------------	------------------	-----------------	-------------	---

FED. ROAD DIST. NO.	STATE	FEDERAL AID PROJECT NO.	SHEET NO.	TOTAL SHEETS
1	N.Y.	APD-221(21)	106	200

SOUTHERN TIER EXPRESSWAY SECTION 6R
LOWMAN - WAVERLY PART I
CHEMUNG COUNTY

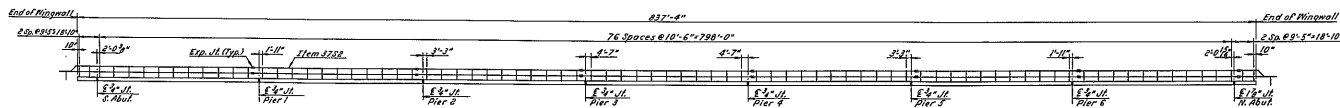


TYPICAL CROSS SECTION
Scale: 3/4"=1'-0"



SLAB PLAN
Scale: 3/4"=1'-0"

REFERENCES:
1. For Bar List, see Eng. No. 12.



TYPICAL RAILING ELEVATION
No Scale

Notes: For dimensions between railing posts and intersection of E fascia stringers and E abutment bearings, see abutment drawings.
For Railing Details, see Eng. No. 12.

Note Use Special Post of Worth Abutment.

By	Date	Revised
As Checked by <i>J. B. Miller</i>		
Designed by <i>J. B. Miller</i>		
Checked by <i>J. B. Miller</i>		
Drawn by <i>J. B. Miller</i>		
Field Checked by <i>J. B. Miller</i>		

BRIDGE NO. 9-1
RELOCATED C.R. NO. 9 OVER CHEMUNG RIVER

SLAB PLAN AND CROSS SECTION

Prepared and recommended by *J. B. Miller*
Reviewed & OK'd

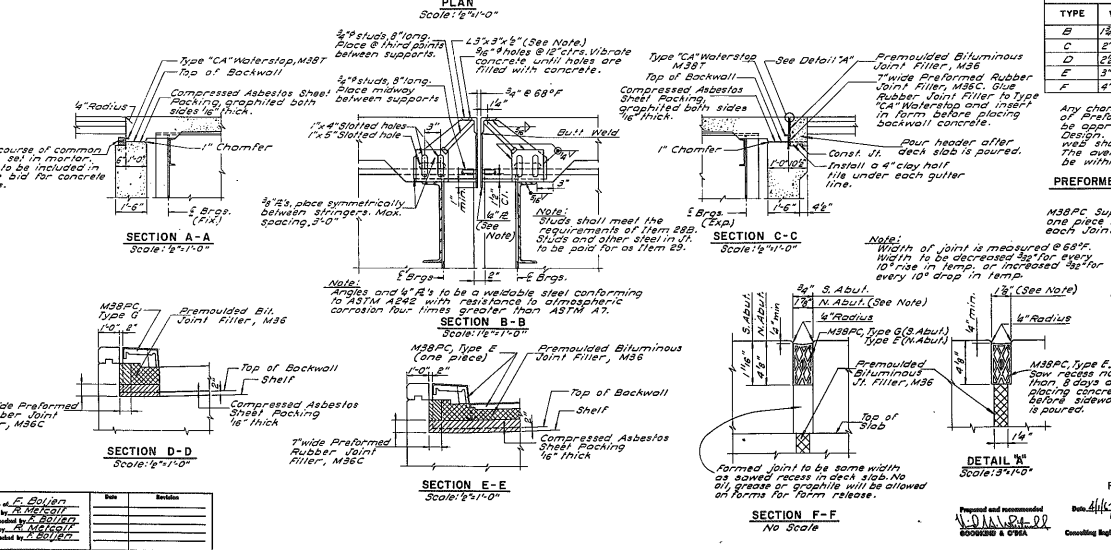
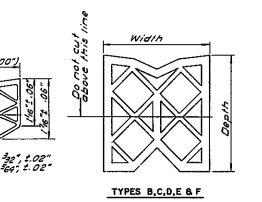
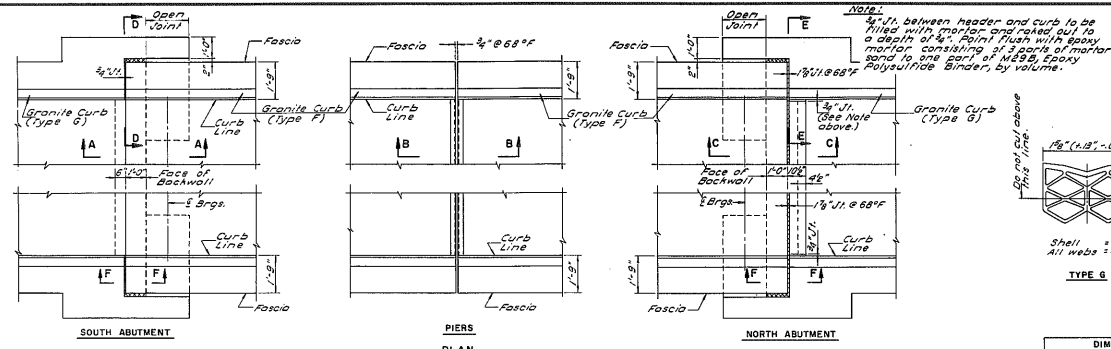
Date: 4/1/67
Consulting Engineer

DATE	NO.	SCALE	DATE	GOODKIND & O'DEA CONSULTING ENGINEERS
10/21/67	AS SHOWN	4/1/67		



FED. ROAD DIST. NO.	STATE	FEDERAL PROJECT NO.	SHEET NO.	TOTAL SHEETS
1	N.Y.	APD-221(21)	197	200

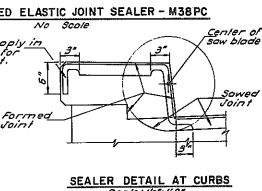
SOUTHERN TIER EXPRESSWAY SECTION 6R
LOWMAN - HAVENLY PART 1
CHEMUNG COUNTY



DIMENSIONS FOR TYPES B, C, D, E & F

TYPE	WIDTH	DEPTH	THICKNESS	
			SHELL	WEBS
B	15" ± .02"	8" ± .02"	1/2" ± .02"	3/4" ± .02"
C	21" ± .02"	8" ± .02"	3/4" ± .02"	3/4" ± .02"
D	25" ± .02"	8" ± .02"	3/4" ± .02"	3/4" ± .02"
E	31" ± .02"	8" ± .02"	3/4" ± .02"	3/4" ± .02"
F	41" ± .02"	8" ± .02"	3/4" ± .02"	3/4" ± .02"

Any changes in the shape or dimensions of Preformed Elastic Joint Sealer must be approved by the Deputy Chief Engineer. Design. The minimum thickness of any web shall not be less than as specified. The average thickness of all webs shall be within the tolerances specified.

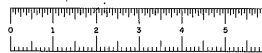


REFERENCE: Top Detail of Waterstop Installation see Dwg. No. 6.

BRIDGE NO. 9-1
RELOCATED C.R. NO. 9 OVER CHEMUNG RIVER
JOINT DETAILS

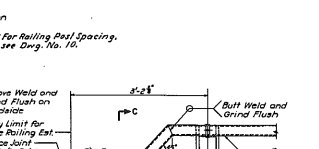
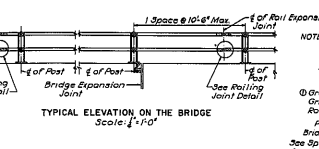
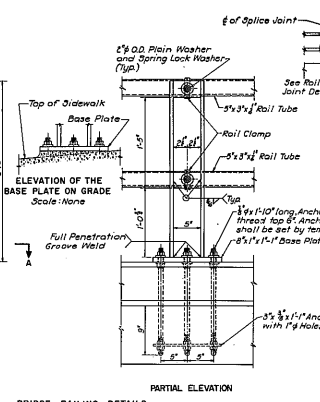
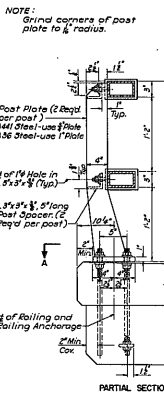
Prepared and recommended by: *[Signature]*
Checked by: *[Signature]*
Date: 11/07/13
Scale: As Shown
GROOMING & O'NEA CONSULTING ENGINEERS

By	Date	Revised



FED. ROAD DIST. NO.	STATE	FEDERAL AID PROJECT NO.	SHEET NO.	TOTAL SHEETS
1	K.T.	APD-221(21)	128	200

SOUTHERN TIER EXPRESSWAY SECTION 6R
LOWMAN - WAVERLY PART I
CHEMUNG COUNTY



NOTES:

All railing is to be fabricated and erected so that the rails are parallel to each other and to the parapet and so that the posts are truly vertical. Since the finished railing must meet all requirements of rise, alignment, grade and verticality of post to the full satisfaction of the Engineer, it is suggested that complete field measurements be made before any shop fabrication is performed.

The Base Plates shall be perpendicular to the post unless otherwise noted. When the railing is to be placed on a prepared surface, the Base Plate may be parallel to the grade or may be perpendicular to the post and made level by the use of beveled shims.

Tubular steel rails, rail clamp assemblies including studs, nuts and washers, posts, post nuts if required, post spacers, base plates, expansion joints and splice joint railing assemblies including steel bridge railing connection to the box beam guide railing and any necessary shims and/or post shall be paid for under the railing item.

Anchor studs, nuts and washers and anchor plates shall be paid for under Item 9.

After the anchor stud nuts have been placed and tightened to the satisfaction of the Engineer, the studs shall be cut off 1/8-inch above the nut and painted.

Shims shall be continuous over a minimum of three posts. On "H" type supports the shims may be continuous over two posts.

Materials used in the manufacture of this railing shall conform to the requirements and/or specifications listed below.

Rail Posts - ASTM Designation A500 Grade B

Rail Clamps - ASTM Designation A36

Clamp studs, nuts and washers - ASTM Designation A307

Channel Rail Splices - ASTM Designation: A56 Tubular Rail Splices - ASTM Designation A500 Grade B or A513

Splice Plates - ASTM Designation A36

3/4" Post Plates - ASTM Designation A41

1" Post Plates - ASTM Designation A36

Post Spacers - Same as post plate material

Splice bolts, nuts and washers - ASTM Designation A307

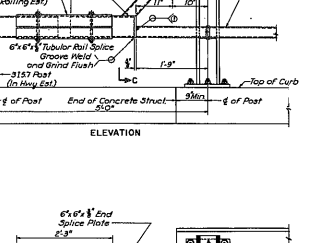
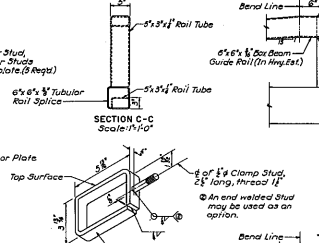
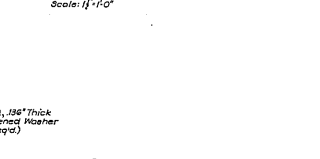
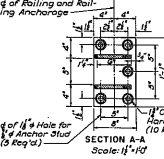
Anchor studs, nuts and washers - ASTM Designation A36

Post Nut Plates - Same as post plate material

Face Plates - ASTM Designation A36

Beveled Shims - Material Specification M13

Galvanized Steel - All components of this railing including anchor studs, nuts, and washers shall be galvanized in accordance with Material Specification M13. Anchor studs shall have a Class 2B thread fit prior to galvanizing. The cut portion of the anchor studs shall be given one fluid coat of Dull Orange Primer and two fluid coats of Dark Mixed Aluminic Paint conforming to the requirements of Material Specifications M13C and M13D in that order.



STEEL BRIDGE RAILING CONNECTION TO BOX BEAM GUIDE RAILING
Scale: 1/2"=1'-0"

PLAN

1/2" Hole in Top and Bottom of 5/8"x3/4" Tubular Rail Splice and in Bottom of 5/8"x3/4" Rail Tube.

1/2" Hole in Box Beam Guide Rail (on Hwy. Ext.)

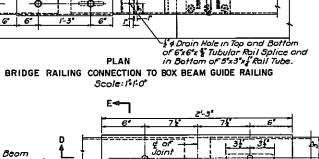
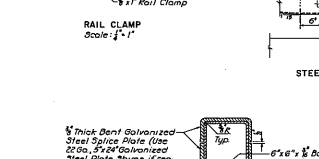
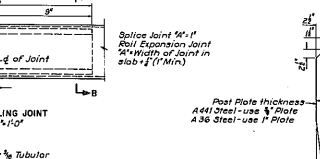
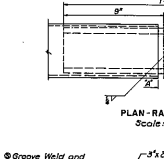
1/2" Hole in Bent Galvanized Steel Splice Plate, Top and Bottom

1/2" Hole in Bent Galvanized Steel Tubular Rail Splice, Top and Bottom

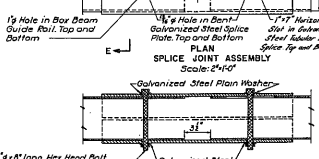
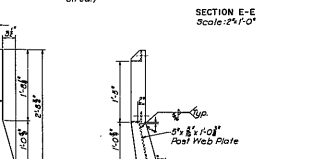
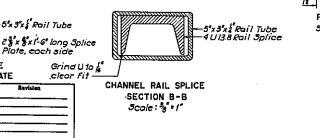
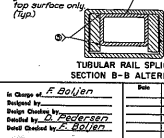
1/2" Horizontal Slot in Galvanized Steel Tubular Rail Splice, Top and Bottom

Galvanized Steel Plain Washer

Scale: 1/2"=1'-0"



BRIDGE NO. 9-1
RELOCATED C.R. NO. 9 OVER CHEMUNG RIVER
RAILING DETAILS



In Charge of: *R. Bolten*

Designed by: *R. Bolten*

Checked by: *R. Bolten*

Drawn by: *R. Bolten*

Date	Revisions

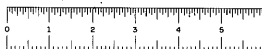
Prepared and recommended by: *R. Bolten*

Checked and approved by: *R. Bolten*

GOODING & ODEA Consulting Engineers

Date: 4/14

DWG. NO.	SCALE	DATE	GOODING & ODEA CONSULTING ENGINEERS
12013	As Shown	4/14	



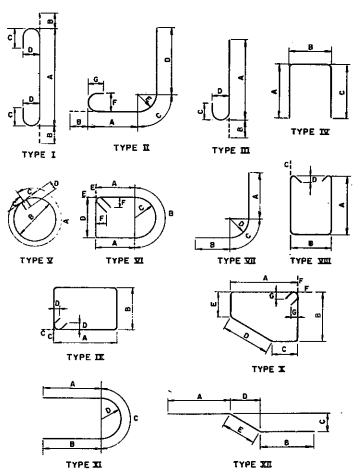
E.A.S.T.E. 67-4

FED. ROAD DIST. NO.	STATE	FEDERAL AID PROJECT NO.	SHEET NO.	TOTAL SHEETS
1	N.Y.	APD-22(21)	108 of 200	200

SOUTHERN TIER EXPRESSWAY SECTION 6R
LOWMAN - WAVERLY PART I
CHEMUNG COUNTY

MARK	TYPE	LENGTH	QUANTITY	DIMENSIONS	NOTES
			TOTAL PER UNIT	A B C D E F G	
NORTH ABUTMENT (1 REQUIRED)					
SAL11	SA	2'-6"	44		
SAL12	SA	28'-6"	20		
SAL13	SA	49'-0"	10		
SAL14	SA	8'-0"	20		
SAL15	SA	4'-3"	20		
SAL16	SA	4'-7"	20		
SAL17	SA	10'-3"	20		
SAL18	SA	9'-7"	20		
SAL19	SA	17'-3"	20		
SAL20	SA	6'-0"	20		
SAL21	SA	5'-6"	20		
SAL22	SA	28'-7"	6		
SAL23	SA	10'-3"	6		
SAL24	SA	23'-0"	6		
SAL25	SA	23'-0"	6		
SAL26	SA	10'-3"	12		
SAL27	SA	7'-7"	16		
SAL28	SA	15'-0"	16	3'-8" 7'-6" 0"	
SAL29	SA	15'-0"	16		
SAL30	SA	15'-0"	16		
SAL31	SA	3'-7"	20		
SAL32	SA	4'-4"	8	1'-0" 8" 1'-0"	
SAL33	SA	2'-5"	20		
SAL34	SA	6'-7"	8	2'-0" 2'-7" 2'-0"	
SAL35	SA	9'-6"	22	3'-0" 3'-0" 3'-0"	
SAL36	SA	7'-6"	16	3'-0" 3'-0" 0"	
SAL37	SA	4'-10"	30	2'-4" 2'-4"	
SAL38	SA	48'-6"	8		Piles
BS21	SA	7'-3"	192		
SOUTH ABUTMENT (1 REQUIRED)					
SAR11	SA	5'-6"	44		
SAR12	SA	28'-6"	20		
SAR13	SA	49'-0"	10		
SAR14	SA	8'-0"	20		
SAR15	SA	4'-3"	20		
SAR16	SA	4'-7"	20		
SAR17	SA	10'-3"	20		
SAR18	SA	9'-7"	20		
SAR19	SA	17'-3"	20		
SAR20	SA	6'-0"	20		
SAR21	SA	5'-6"	20		
SAR22	SA	28'-7"	6		
SAR23	SA	10'-3"	6		
SAR24	SA	23'-0"	6		
SAR25	SA	23'-0"	6		
SAR26	SA	10'-3"	12		
SAR27	SA	7'-7"	16		
SAR28	SA	15'-0"	16	3'-8" 7'-6" 0"	
SAR29	SA	15'-0"	16		
SAR30	SA	15'-0"	16		
SAR31	SA	3'-7"	20		
SAR32	SA	4'-4"	8	1'-0" 8" 1'-0"	
SAR33	SA	2'-5"	20		
SAR34	SA	6'-7"	8	2'-0" 2'-7" 2'-0"	
SAR35	SA	9'-6"	22	3'-0" 3'-0" 3'-0"	
SAR36	SA	7'-6"	16	3'-0" 3'-0" 0"	
SAR37	SA	4'-10"	30	2'-4" 2'-4"	
SAR38	SA	48'-6"	8		Piles
BS22	SA	7'-3"	192		

MARK	TYPE	LENGTH	QUANTITY	DIMENSIONS	NOTES
			TOTAL PER UNIT	A B C D E F G	
PIER 1 (1 REQUIRED)					
SP11	SI	8'-6"	20		
SP12	SI	28'-0"	20		
SP13	SI	4'-2"	20		
SP14	SI	28'-10"	20		
SP15	SI	3'-4"	20		
SP16	SI	45'-8"	20		
SP17	SI	6'-0" 28'-10"	20	1'-0" 1'-0" 28'-10"	d = 1'-3"
SP18	SI	23'-6"	10		
SP19	SI	7'-3"	2	1'-0" 7'-3" 3'-4" 1'-3"	Piles
SP20	SI	7'-3"	20		
SP21	SI	3'-7"	20	2'-4" 2'-4" 2'-4"	
SP22	SI	12'-9"	10	3'-0" 3'-0" 1'-4" 2'-4" 2'-4"	
SP23	SI	13'-9"	6		
PIERS 2, 3, 4, 5 & 6 (5 REQUIRED)					
SP24	SI	8'-6"	300	20	
SP25	SI	28'-0"	160	20	
SP26	SI	4'-2"	250	20	
SP27	SI	23'-10"	350	20	
SP28	SI	3'-4"	200	20	
SP29	SI	45'-8"	100	20	
SP30	SI	6'-0" 28'-10"	160	30 1'-0" 1'-0" 28'-10"	d = 2'-0"
SP31	SI	23'-6"	60	12	
SP32	SI	7'-3"	10	2 1'-0" 7'-3" 3'-4" 1'-3"	Piles
SP33	SI	7'-3"	200	20	
SP34	SI	3'-7"	200	20	2'-4" 2'-4" 2'-4"
SP35	SI	12'-9"	10	3'-0" 3'-0" 1'-4" 2'-4" 2'-4"	
SP36	SI	13'-9"	30	6 3'-0" 3'-0" 1'-4" 2'-4" 2'-4"	
SLAB SPANS 8 & 7 (2 REQUIRED)					
SS21	SL	38'-3"	270	255	
SS22	SL	47'-0"	460	450	7' 5" 5"
SS23	SL	45'-10"	460	450	
SS24	SL	41'-4"	460	450	1'-3" 9' 6" 4"
SS25	SL	38'-3"	24	20	
SLAB SPANS 2, 3, 4, 5 & 6 (5 REQUIRED)					
SS26	SL	47'-0"	1140	1120	4'-0" 7' 5" 5"
SS27	SL	45'-10"	1120	1100	
SS28	SL	41'-4"	1120	1100	1'-3" 9' 6" 4"
SS29	SL	38'-3"	120	120	
SS30	SL	38'-3"	60	70	



Note: All bar dimensions are out to out.

In Charge of Design: S. Rajan
 Checked by: S. Rajan
 Design Checked by: S. Rajan
 Detail Checked by: S. Rajan

BRIDGE NO. 9-1
 RELOCATED C.R. NO. 9 OVER CHEMUNG RIVER
 BAR LIST
 Prepared and recommended by: W. J. O'Connell
 Checked by: G. O'Connell
 Date: 4/1/49
 Consulting Engineers: GODDARD & O'NEAL
 Scale: 1/8" = 1'-0"
 Date: 4/1/49
 Drawing No. 108
 SHEET NO. 108 OF 200
 GOODING & O'NEAL
 CONSULTING ENGINEERS