

# Manholes

**A0721 Monitoring Well Manholes**

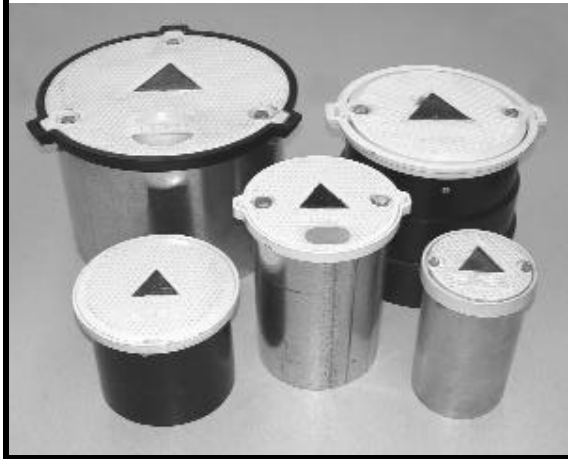

**A0717 Standard Manholes**



**A0717 Square Manholes and Vaults**



**A0717 Composite Manholes**



# A0721 Monitoring Well Manholes

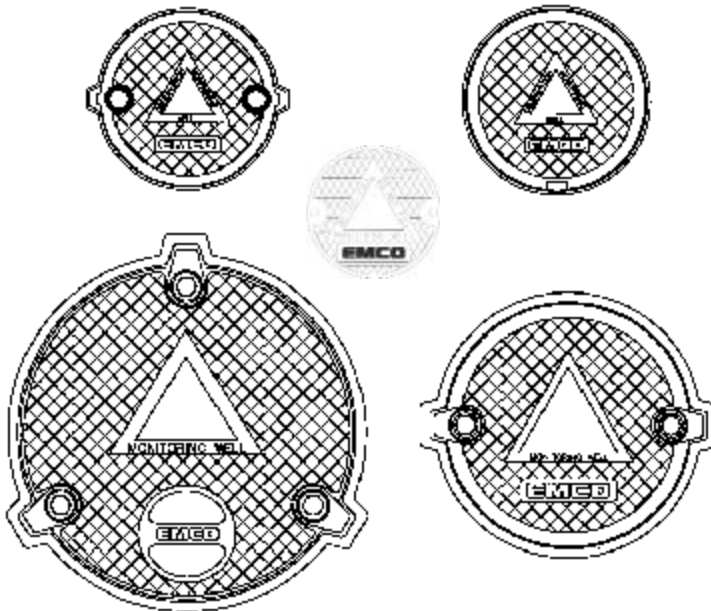

- Painted ductile iron lid and rim with black triangle
- Optional steel or polyethylene skirt
- Heavy-duty, 100% welded skirts available
- Bolt-down units have water tight lids
- Stainless steel bolts
- Alignment tabs on bolt-down versions
- Fully painted inside and out
- Meets AASHTO H20 wheel loading

	Part Number	Style	Skirt Type	A	B	C	Weight
<b>6"</b>	A0721-106	Bolt-down	8" Steel	6.6"	4.8"	9.5"	7.7 lbs.
	A0721-008L	Lay-in	8" Poly	9.8"	7.8"	8.0"	12.0 lbs.
	A0721-188L	Lay-in	8" Steel	9.8"	7.8"	8.0"	14.7 lbs.
<b>8"</b>	A0721-008	Bolt-down	12" Poly	10.4"	6.0"	12.0"	9.8 lbs.
	A0721-088	Bolt-down	8" Poly	10.4"	6.0"	8.0"	9.5 lbs.
	A0721-108	Bolt-down	12" Steel	10.4"	6.0"	12.0"	12.0 lbs.
	A0721-188	Bolt-down	8" Steel	10.4"	6.0"	8.0"	11.6 lbs.
	A0721-208	Bolt-down	12" HD Steel	10.4"	6.0"	12.0"	14.7 lbs.
<b>12"</b>	A0721-001	Bolt-down	12" Poly	15.1"	9.4"	12.0"	23.0 lbs.
	A0721-101	Bolt-down	12" Steel	15.1"	9.4"	12.0"	27.0 lbs.
	A0721-119	Bolt-down	19.5" Steel	15.1"	9.4"	19.5"	31.6 lbs.
	A0721-128	Bolt-down	8" Poly	15.1"	9.4"	8.0"	21.5 lbs.
	A0722-001	Bolt-down	12" Poly	15.1"	9.4"	12.0"	23.8 lbs.
w/locking cap and collar							
<b>18"</b>	A0721-018	Bolt-down	12" Steel	19.4"	13.8"	12.0"	58.5 lbs.
	A0721-118	Bolt-down	17" Steel	19.4"	13.8"	17.0"	69.5 lbs.

**Optional Item:** A0720-001 Locking Cap and Collar

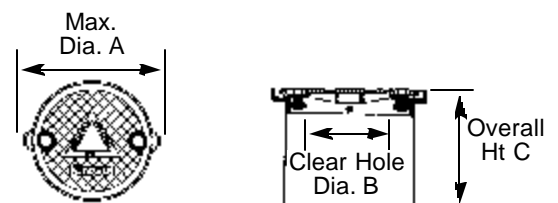

# A0721 Monitoring Well Manholes

Stainless steel bolts - no more rusted bolts

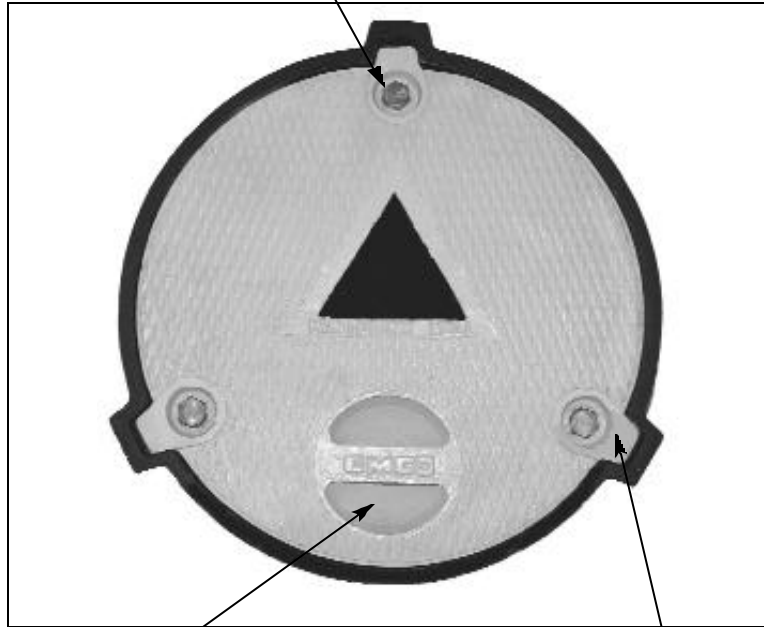

Built-in side handle on 18" models -  
one hand opening and positioning

Alignment tabs - bolt holes  
line up first time, every time



8" models available with heavy-duty skirts. 100% welded skirt and seam.

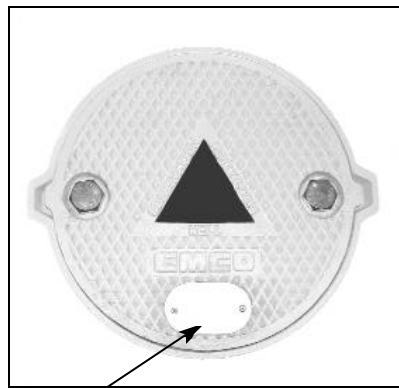

ID tag available on 8" models;  
large enough for all new  
regulatory requirements

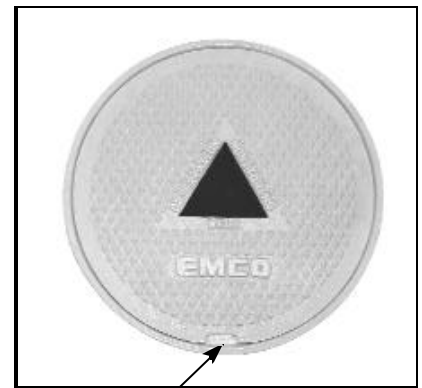

Large notch on 8" lay-in eliminates  
broken screwdrivers

Custom skirt height and gauge are available upon request.

# A0717 Square Manholes And Vaults

## Locking Vault Manholes

- Double hinged lid opens and folds back to 180 degrees
- Lock-access lid permanently fastened with anti-theft chain; stainless steel bolt also permanently attached

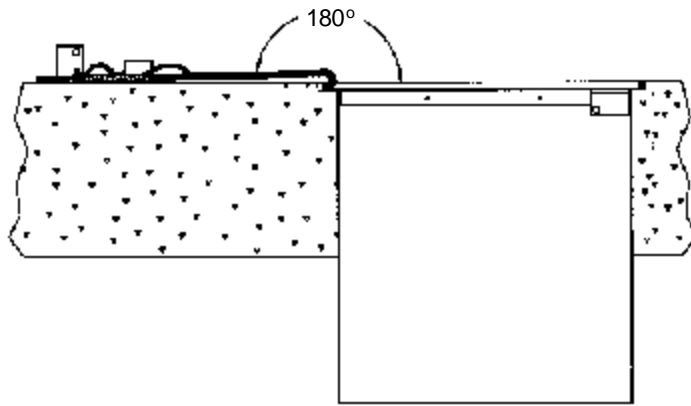

## All Emco Wheaton Square Manholes

- Fully painted inside and out
- 3/8" heavy duty diamond plate lid
- 16 gauge steel skirt
- Meet AASHTO H20 wheel loading

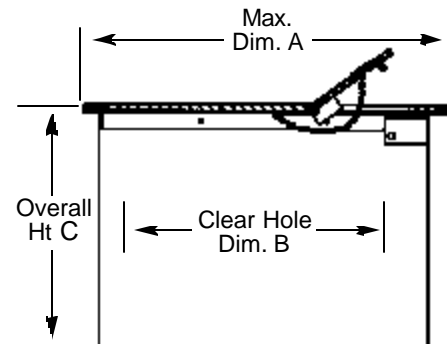

	Part Number	Style	A	B	C	Weight
<b>18"</b>	A0717-718	Lay-In	20.3"	18.0"	9.6"	66.6 lbs.
	A0717-718BW	Bolt-Down Water-tight	20.3"	13.8"	9.6"	66.8 lbs.
	A0717-718ABW	Bolt-Down Water-tight	20.3"	13.8"	16.6"	78.4 lbs.
	A0717-718VW	Locking Vault Water-tight	20.3"	18.1"	18.6"	78.2 lbs.
<b>24"</b>	A0717-724	Lay-In	25.0"	22.5"	9.6"	86.0 lbs.
	A0717-724A	Lay-In	25.0"	22.5"	24.6"	116.5 lbs.
	A0717-724BW	Bolt-Down Water-tight	25.0"	18.5"	9.6"	86.2 lbs.
	A0717-724ABW	Bolt-Down Water-tight	25.0"	18.5"	24.6"	116.7 lbs.
	A0717-724V	Locking Vault	24.9"	21.1"	24.6"	116.5 lbs.
	A0717-724VW	Locking Vault Water-tight	24.9"	21.1"	24.6"	116.5 lbs.
	A0717-724VWL	Locking Vault Water-tight	24.9"	21.1"	24.6"	119.5 lbs.

V = Hinged; B = Bolt-down; W = Water-tight; L = Lift Assist Lid

# A0717 Square Vaults

Double hinged lid opens and folds back to 180 degrees

180°

Lock-access lid permanently fastened with anti-theft chain; stainless steel bolt is also permanently attached

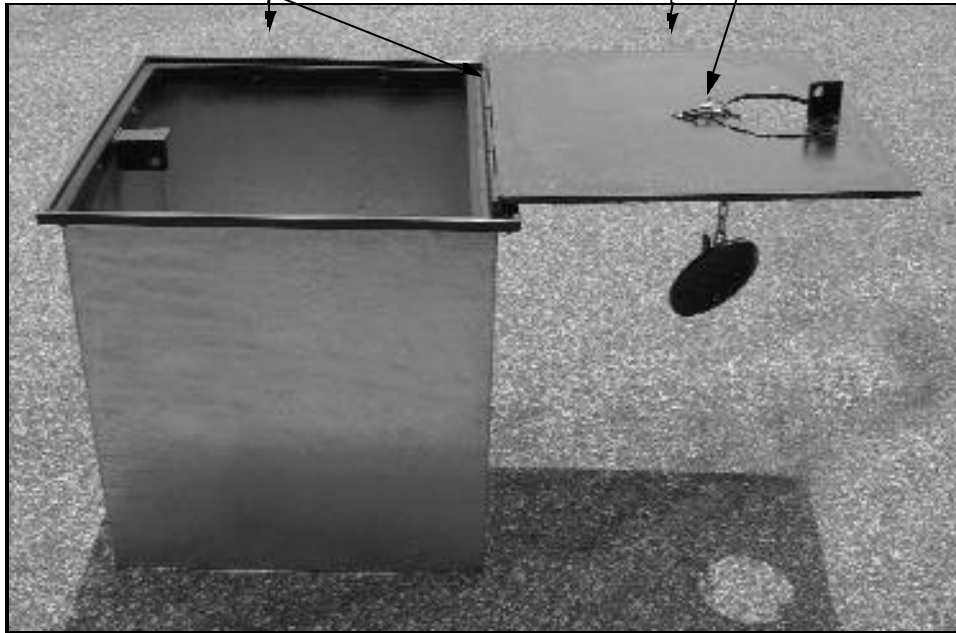

## ***Lift Assisted Vault***

- Easily opens with one hand
- Custom skirt height and gauge available upon request

# A0717 Composite Manholes



- Reduces lid weight 44% to 57% compared to steel lids
- Fully painted inside and out
- Lightweight cover
- Durable composite construction of fiberglass and polyester resin
- Easy lid removal and replacement
- Meets AASHTO H20 wheel loading

Available in two lifting styles

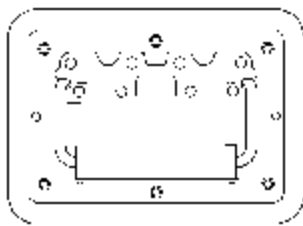

Handle Lift

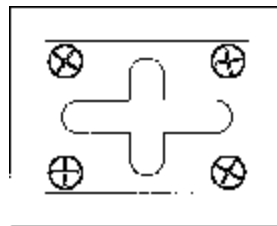

Euro Lift

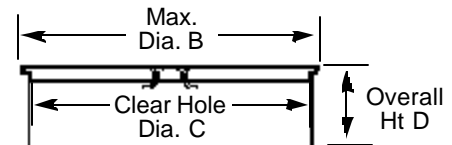
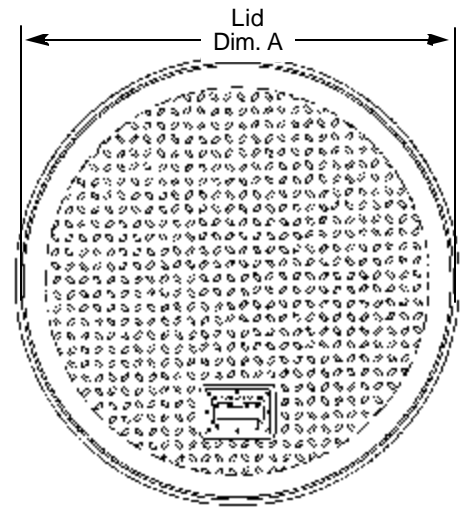

	Part Number	Style	Skirt Type	Lid Type	A	B	C	D	Weight
<b>38"</b>	A0717-138	Lay-in	Steel	Composite	39.1"	40.3"	38.0"	10.5"	101.0 lbs.
	A0717-138BW	Bolt-Down WT	Steel	Composite	39.1"	40.3"	36.6"	10.5"	101.5 lbs.
<b>42"</b>	A0717-142	Lay-in	Steel	Composite	43.8"	44.9"	42.6"	10.5"	132.0 lbs.
	A0717-142BW	Bolt-Down WT	Steel	Composite	43.8"	44.9"	41.2"	10.5"	132.5 lbs.

# A0717 Standard Manholes

- Open throat design for easy access
- Optional steel or polyethylene skirt (8", 12", 18")
- Fully painted inside and out
- Bolt-down units have water-tight lids
- Built-in handle (18")
- Recessed handle (24" - 42")
- Meets AASHTO H20 wheel loading

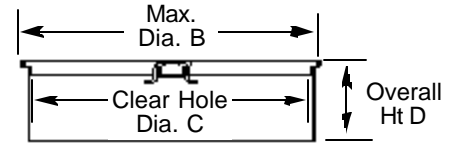
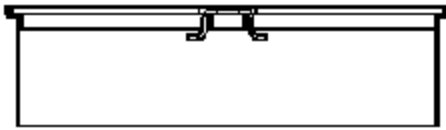
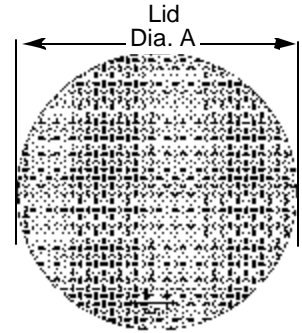

	Part Number	Style	Skirt Type	Lid Type	A	B	C	D	Weight
<b>8"</b>	A0717-188	Lay-in	8" Steel	Cast Iron	8.9"	10.4"	6.0"	8.0"	22.3 lbs.
	A0717-008	Lay-in	12" Poly	Cast Iron	8.9"	10.4"	6.0"	12.0"	16.0 lbs.
	A0717-108	Lay-in	12" Steel	Cast Iron	8.9"	10.4"	6.0"	12.0"	23.0 lbs.
<b>12"</b>	A0717-128	Lay-in	8" Steel	Cast Iron	12.4"	13.8"	11.3"	8.0"	32.0 lbs.
	A0717-022	Lay-in	12" Poly	Cast Iron	12.4"	13.8"	11.3"	12.0"	24.0 lbs.
	A0717-122	Lay-in	12" Steel	Cast Iron	12.4"	13.8"	11.3"	12.0"	34.0 lbs.
<b>18"</b>	A0717-018	Lay-in	10" Steel	Cast Iron	17.2"	18.4"	16.2"	10.0"	45.0 lbs.
	A0717-018A	Lay-in	18" Steel	Cast Iron	17.2"	18.4"	16.2"	18.0"	65.7 lbs.
	A0717-018B	Bolt-Down WT	10" Steel	Cast Iron	17.2"	18.4"	13.8"	10.0"	45.5 lbs.
	A0717-118	Lay-in	18" Poly	Cast Iron	17.2"	18.4"	16.2"	18.0"	43.0 lbs.
<b>24"</b>	A0717-024	Lay-in	10" Steel	Steel	23.6"	24.8"	22.5"	10.0"	67.0 lbs.
	A0717-124	Bolt-Down WT	10" Steel	Steel	23.6"	24.8"	21.1"	10.0"	67.5 lbs.
<b>30"</b>	A0717-030	Lay-in	10" Steel	Steel	29.6"	30.8"	28.3"	10.0"	132.0 lbs.
<b>36"</b>	A0717-036	Lay-in	10" Steel	1/2" Steel	35.6"	36.5"	34.0"	10.0"	193.0 lbs.
	A0717-036B	Bolt-Down WT	10" Steel	1/2" Steel	35.6"	36.5"	32.8"	10.0"	193.5 lbs.
	A0717-136	Lay-in	10" Steel	3/8" Steel	35.6"	36.5"	34.0"	10.0"	163.0 lbs.
<b>38"</b>	A0717-038	Lay-in	10" Steel	1/2" Steel	39.6"	40.5"	36.5"	10.0"	235.0 lbs.
<b>42"</b>	A0717-042	Lay-in	10" Steel	5/8" Steel	41.6"	42.8"	40.3"	10.0"	310.0 lbs.
	A0717-042A	Lay-in	10" Steel	1/2" Steel	41.6"	42.8"	40.3"	10.0"	237.0 lbs.

WT=Water-tight

**EMCO**®  
WHEATON RETAIL

**Emco** - *The Preferred  
Name in Monitoring Well  
Manholes and Vaults*

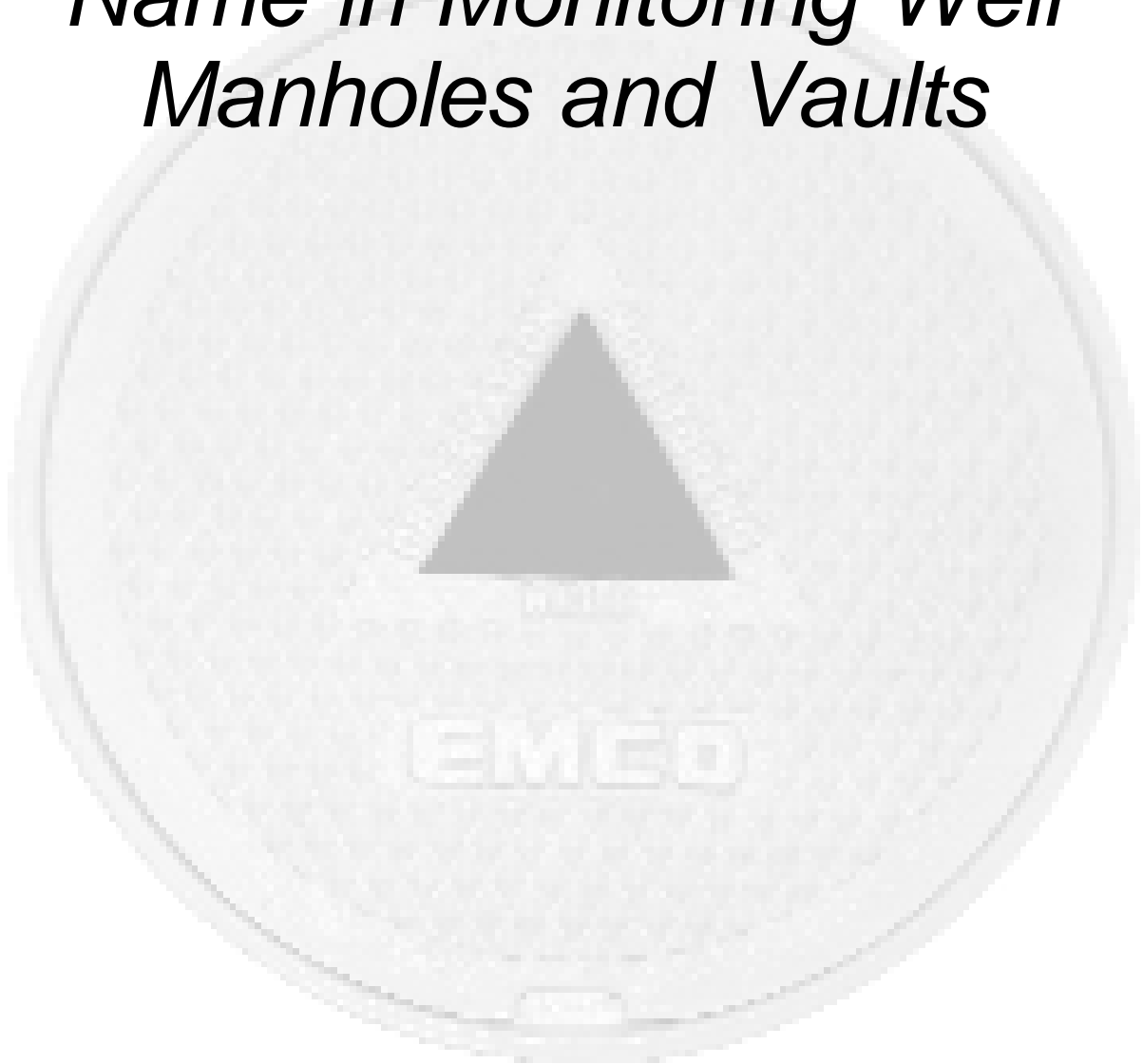

**Emco Wheaton Retail Corporation**  
2300 Industrial Park Drive • Wilson, North Carolina 27893  
252-243-0150 • 252-243-4603 (fax) • [www.emcoretail.com](http://www.emcoretail.com)

Form O-1001  
Date 07/03