

# IndraDyn S

MS2N Synchronous Motors

**Operating instructions**  
**R911347581**

Edition 03

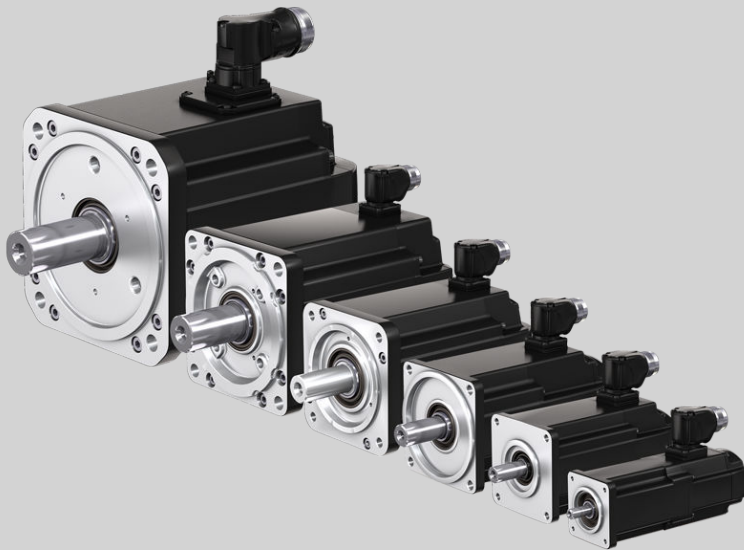

## Purpose of Documentation

This documentation

- instructs assembly, operating and maintenance personnel
- contains basic notes about assembly, operation and maintenance of the motors

## Record of revisions

Edition 03, 2018/04

See ["Editions of this documentation" on page 1](#)

## Copyright

© Bosch Rexroth AG 2018

This document, as well as the data, specifications and other information set forth in it, are the exclusive property of Bosch Rexroth AG. It may not be reproduced or given to third parties without its consent.

## Liability

The specified data is intended for product description purposes only and shall not be deemed to be a guaranteed characteristic unless expressly stipulated in the contract. All rights are reserved with respect to the content of this documentation and the availability of the product.

## Editorial department

Engineering Project-Office and Infrastructure - Editorial and Provisioning (JoWa)

<b>D</b> Deutsch	<b>USA</b> English	<b>F</b> Français
<p><b>⚠️ WARNUNG</b> Lebensgefahr bei Nichtbeachtung der nachstehenden Sicherheitshinweise!</p> <p>Nehmen Sie die Produkte erst dann in Betrieb, nachdem Sie die mit dem Produkt gelieferten Unterlagen und Sicherheitshinweise vollständig durchgelesen, verstanden und beachtet haben.</p> <p>Sollten Ihnen keine Unterlagen in Ihrer Landessprache vorliegen, wenden Sie sich an Ihren zuständigen Rexroth-Vertriebspartner.</p> <p>Nur qualifiziertes Personal darf an Antriebskomponenten arbeiten.</p> <p>Nähere Erläuterungen zu den Sicherheitshinweisen entnehmen Sie Kapitel 1 dieser Dokumentation.</p>	<p><b>⚠️ WARNUNG</b> Danger to life in case of non-compliance with the below-mentioned safety instructions!</p> <p>Do not attempt to install or put these products into operation until you have completely read, understood and observed the documents supplied with the product.</p> <p>If no documents in your language were supplied, please consult your Rexroth sales partner.</p> <p>Only qualified persons may work with drive components.</p> <p>For detailed explanations on the safety instructions, see chapter 1 of this documentation.</p>	<p><b>⚠️ AVERTISSEMENT</b> Danger de mort en cas de non-respect des consignes de sécurité figurant ci-après !</p> <p>Ne mettez les produits en service qu'après avoir lu complètement et après avoir compris et respecté les documents et les consignes de sécurité fournis avec le produit.</p> <p>Si vous ne disposez pas de la documentation dans votre langue, merci de consulter votre partenaire Rexroth.</p> <p>Seul un personnel qualifié est autorisé à travailler sur les composants d'entraînement.</p> <p>Vous trouverez des explications plus détaillées relatives aux consignes de sécurité au chapitre 1 de la présente documentation.</p>
<p><b>⚠️ WARNUNG</b> Hohe elektrische Spannung! Lebensgefahr durch elektrischen Schlag!</p> <p>Betreiben Sie Antriebskomponenten nur mit fest installiertem Schutzleiter.</p> <p>Schalten Sie vor Zugriff auf Antriebskomponenten die Spannungsversorgung aus.</p> <p>Beachten Sie die Entladezeiten von Kondensatoren.</p>	<p><b>⚠️ WARNUNG</b> High electrical voltage! Danger to life by electric shock!</p> <p>Only operate drive components with a permanently installed equipment grounding conductor.</p> <p>Disconnect the power supply before accessing drive components.</p> <p>Observe the discharge times of the capacitors.</p>	<p><b>⚠️ AVERTISSEMENT</b> Tensions électriques élevées ! Danger de mort par électrocution !</p> <p>N'exploitez les composants d'entraînement que si un conducteur de protection est installé de manière permanente.</p> <p>Avant d'intervenir sur les composants d'entraînement, coupez toujours la tension d'alimentation.</p> <p>Tenez compte des délais de décharge de condensateurs.</p>
<p><b>⚠️ WARNUNG</b> Gefahrbringende Bewegungen! Lebensgefahr!</p> <p>Halten Sie sich nicht im Bewegungsbereich von Maschinen und Maschinenteilen auf.</p> <p>Verhindern Sie den unbeabsichtigten Zutritt für Personen.</p> <p>Bringen Sie vor dem Zugriff oder Zutritt in den Gefahrenbereich die Antriebe sicher zum Stillstand.</p>	<p><b>⚠️ WARNUNG</b> Dangerous movements! Danger to life!</p> <p>Keep free and clear of the ranges of motion of machines and moving machine parts.</p> <p>Prevent personnel from accidentally entering the range of motion of machines.</p> <p>Make sure that the drives are brought to safe standstill before accessing or entering the danger zone.</p>	<p><b>⚠️ AVERTISSEMENT</b> Mouvements entraînant une situation dangereuse ! Danger de mort !</p> <p>Ne séjournez pas dans la zone de mouvement de machines et de composants de machines.</p> <p>Évitez tout accès accidentel de personnes.</p> <p>Avant toute intervention ou tout accès dans la zone de danger, assurez-vous de l'arrêt préalable de tous les entraînements.</p>

D Deutsch	USA English	F Français
<p><b>⚠ WARNUNG</b>  <b>Elektromagnetische / magnetische Felder! Gesundheitsgefahr für Personen mit Herzschrittmachern, metallischen Implantaten oder Hörgeräten!</b></p> <p>Zutritt zu Bereichen, in denen Antriebskomponenten montiert und betrieben werden, ist für oben genannten Personen untersagt bzw. nur nach Rücksprache mit einem Arzt erlaubt.</p>	<p><b>⚠ WARNING</b> Electromagnetic / magnetic fields! Health hazard for persons with heart pacemakers, metal implants or hearing aids!</p> <p>The above-mentioned persons are not allowed to enter areas in which drive components are mounted and operated, or rather are only allowed to do this after they consulted a doctor.</p>	<p><b>⚠ AVERTISSEMENT</b> Champs électromagnétiques / magnétiques ! Risque pour la santé des porteurs de stimulateurs cardiaques, d'implants métalliques et d'appareils auditifs !</p> <p>L'accès aux zones où sont montés et exploités les composants d'entraînement est interdit aux personnes susmentionnées ou bien ne leur est autorisé qu'après consultation d'un médecin.</p>
<p><b>⚠ VORSICHT</b> Heiße Oberflächen (&gt; 60 °C)! Verbrennungsgefahr!</p> <p>Vermeiden Sie das Berühren von metallischen Oberflächen (z. B. Kühlkörpern). Abkühlzeit der Antriebskomponenten einhalten (mind. 15 Minuten).</p>	<p><b>⚠ CAUTION</b> Hot surfaces (&gt; 60 °C [140 °F])! Risk of burns!</p> <p>Do not touch metallic surfaces (e.g. heat sinks). Comply with the time required for the drive components to cool down (at least 15 minutes).</p>	<p><b>⚠ ATTENTION</b> Surfaces chaudes (&gt; 60 °C)! Risque de brûlure !</p> <p>Évitez de toucher des surfaces métalliques (p. ex. dissipateurs thermiques). Respectez le délai de refroidissement des composants d'entraînement (au moins 15 minutes).</p>
<p><b>⚠ VORSICHT</b> Unsachgemäße Handhabung bei Transport und Montage! Verletzungsgefahr!</p> <p>Verwenden Sie geeignete Montage- und Transporteinrichtungen.</p> <p>Benutzen Sie geeignetes Werkzeug und persönliche Schutzausrüstung.</p>	<p><b>⚠ CAUTION</b> Improper handling during transport and mounting! Risk of injury!</p> <p>Use suitable equipment for mounting and transport.</p> <p>Use suitable tools and personal protective equipment.</p>	<p><b>⚠ ATTENTION</b> Manipulation incorrecte lors du transport et du montage ! Risque de blessure !</p> <p>Utilisez des dispositifs de montage et de transport adéquats.</p> <p>Utilisez des outils appropriés et votre équipement de protection personnel.</p>
<p><b>⚠ VORSICHT</b> Unsachgemäße Handhabung von Batterien! Verletzungsgefahr!</p> <p>Versuchen Sie nicht, leere Batterien zu reaktivieren oder aufzuladen (Explosions- und Verätzungsgefahr).</p> <p>Zerlegen oder beschädigen Sie keine Batterien. Werfen Sie Batterien nicht ins Feuer.</p>	<p><b>⚠ CAUTION</b> Improper handling of batteries! Risk of injury!</p> <p>Do not attempt to reactivate or recharge low batteries (risk of explosion and chemical burns).</p> <p>Do not dismantle or damage batteries. Do not throw batteries into open flames.</p>	<p><b>⚠ ATTENTION</b> Manipulation incorrecte de piles! Risque de blessure!</p> <p>N'essayez pas de réactiver des piles vides ou de les charger (risque d'explosion et de brûlure par acide).</p> <p>Ne désassemblez et n'endommagez pas les piles. Ne jetez pas des piles dans le feu.</p>

<b>E</b> Español	<b>P</b> Português	<b>I</b> Italiano
<p><b>⚠ ADVERTENCIA</b> ¡Peligro de muerte en caso de no observar las siguientes indicaciones de seguridad!</p> <p>Los productos no se pueden poner en servicio hasta después de haber leído por completo, comprendido y tenido en cuenta la documentación y las advertencias de seguridad que se incluyen en la entrega.</p> <p>Si no dispusiera de documentación en el idioma de su país, dirijase a su distribuidor competente de Rexroth.</p> <p>Solo el personal debidamente cualificado puede trabajar en componentes de accionamiento.</p> <p>Encontrará más detalles sobre las indicaciones de seguridad en el capítulo 1 de esta documentación.</p>	<p><b>⚠ ATENÇÃO</b> Perigo de vida em caso de inobservância das seguintes instruções de segurança!</p> <p>Utilize apenas os produtos depois de ter lido, compreendido e tomado em consideração a documentação e as instruções de segurança fornecidas juntamente com o produto.</p> <p>Se não tiver disponível a documentação na sua língua, dirija-se ao seu parceiro de venda responsável da Rexroth.</p> <p>Apenas pessoal qualificado pode trabalhar nos componentes de acionamento.</p> <p>Explicações mais detalhadas relativamente às instruções de segurança constam no capítulo 1 desta documentação.</p>	<p><b>⚠ AVVERTENZA</b> Pericolo di morte in caso di inosservanza delle seguenti indicazioni di sicurezza!</p> <p>Mettere in funzione i prodotti solo dopo aver letto, compreso e osservato per intero la documentazione e le indicazioni di sicurezza fornite con il prodotto.</p> <p>Se non dovesse essere presente la documentazione nella vostra lingua, siete pregati di rivolgervi al rivenditore Rexroth competente.</p> <p>Solo personale qualificato può eseguire lavori sui componenti di comando.</p> <p>Per ulteriori spiegazioni riguardanti le indicazioni di sicurezza consultare il capitolo 1 di questa documentazione.</p>
<p><b>⚠ ADVERTENCIA</b> ¡Alta tensión eléctrica! ¡Peligro de muerte por descarga eléctrica!</p> <p>Active sólo los componentes de accionamiento con el conductor protector firmemente instalado.</p> <p>Desconecte la alimentación eléctrica antes de manipular los componentes de accionamiento.</p> <p>Tenga en cuenta los tiempos de descarga de los condensadores.</p>	<p><b>⚠ ATENÇÃO</b> Alta tensão elétrica! Perigo de vida devido a choque elétrico!</p> <p>Opere componentes de acionamento apenas com condutores de proteção instalados.</p> <p>Desligue a alimentação de tensão antes de aceder aos componentes de acionamento.</p> <p>Respeite os períodos de descarga dos condensadores.</p>	<p><b>⚠ AVVERTENZA</b> Alta tensione elettrica! Pericolo di morte in seguito a scosse elettriche!</p> <p>Mettere in esercizio i componenti di comando solo con conduttore di messa a terra ben installato.</p> <p>Staccare l'alimentazione prima di intervenire sui componenti di comando.</p> <p>Osservare i tempi di scarica del condensatore.</p>
<p><b>⚠ ADVERTENCIA</b> ¡Movimientos peligrosos! ¡Peligro de muerte!</p> <p>No permanezca en la zona de movimiento de las máquinas ni de sus piezas.</p> <p>Impida el acceso accidental de personas.</p> <p>Antes de acceder o introducir las manos en la zona de peligro, los accionamientos se tienen que haber parado con seguridad.</p>	<p><b>⚠ ATENÇÃO</b> Movimentos perigosos! Perigo de vida!</p> <p>Não permaneça na área de movimentação das máquinas e das peças das máquinas.</p> <p>Evite o acesso involuntário para pessoas.</p> <p>Antes de entrar ou aceder à área perigosa, imobilize os acionamentos de forma segura.</p>	<p><b>⚠ AVVERTENZA</b> Movimenti pericolosi! Pericolo di morte!</p> <p>Non sostare nelle zone di manovra delle macchine e delle loro parti.</p> <p>Impedire un accesso non autorizzato per le persone.</p> <p>Prima di accedere alla zona di pericolo, arrestare e bloccare gli azionamenti.</p>

<b>E</b> Español	<b>P</b> Português	<b>I</b> Italiano
<p><b>⚠ ADVERTENCIA</b> ¡Campos electromagnéticos/magnéticos! ¡Peligro para la salud de las personas con marcapasos, implantes metálicos o audífonos!</p> <p>El acceso de las personas arriba mencionadas a las zonas de montaje o funcionamiento de los componentes de accionamiento está prohibido, salvo que lo autorice previamente un médico.</p>	<p><b>⚠ ATENÇÃO</b> Campos eletromagnéticos / magnéticos! Perigo de saúde para pessoas com marcapassos, implantes metálicos ou aparelhos auditivos!</p> <p>Acesso às áreas, nas quais os componentes de acionamento são montados e operados, é proibido para as pessoas em cima mencionadas ou apenas após permissão de um médico.</p>	<p><b>⚠ AVVERTENZA</b> Campi elettromagnetici / magnetici! Pericolo per la salute delle persone portatrici di pacemaker, protesi metalliche o apparecchi acustici!</p> <p>L'accesso alle zone in cui sono installati o in funzione componenti di comando è vietato per le persone sopra citate o consentito solo dopo un colloquio con il medico.</p>
<p><b>⚠ ATENCIÓN</b> ¡Superficies calientes (&gt; 60 °C)! ¡Peligro de quemaduras!</p> <p>Evite el contacto con las superficies calientes (p. ej., disipadores de calor). Observe el tiempo de enfriamiento de los componentes de accionamiento (mín. 15 minutos).</p>	<p><b>⚠ CUIDADO</b> Superfícies quentes (&gt; 60 °C)! Perigo de queimaduras!</p> <p>Evite tocar superficies metálicas (p. ex. radiadores). Respeite o tempo de arrefecimento dos componentes de accionamiento (mín. 15 minutos).</p>	<p><b>⚠ ATTENZIONE</b> Superfici bollenti (&gt; 60 °C)! Pericolo di ustioni!</p> <p>Evitare il contatto con superfici metalliche (ad es. dissipatori di calore). Rispettare i tempi di raffreddamento dei componenti di comando (almeno 15 minuti).</p>
<p><b>⚠ ATENCIÓN</b> ¡Manipulación inadecuada en el transporte y montaje! ¡Peligro de lesiones!</p> <p>Utilice dispositivos de montaje y de transporte adecuados.</p> <p>Utilice herramientas adecuadas y equipo de protección personal.</p>	<p><b>⚠ CUIDADO</b> Manejo incorreto no transporte e montagem! Perigo de ferimentos!</p> <p>Utilize dispositivos de montagem e de transporte adequados.</p> <p>Utilize ferramentas e equipamento de proteção individual adequados.</p>	<p><b>⚠ ATTENZIONE</b> Manipolazione inappropriata durante il trasporto e il montaggio! Pericolo di lesioni!</p> <p>Utilizzare dispositivi di montaggio e trasporto adatti.</p> <p>Utilizzare attrezzi adatti ed equipaggiamento di protezione personale.</p>
<p><b>⚠ ATENCIÓN</b> ¡Manejo inadecuado de las pilas! ¡Peligro de lesiones!</p> <p>No trate de reactivar o cargar pilas descargadas (peligro de explosión y cauterización).</p> <p>No desarme ni dañe las pilas. No tire las pilas al fuego.</p>	<p><b>⚠ CUIDADO</b> Manejo incorreto de baterias! Perigo de ferimentos!</p> <p>Não tente reativar nem carregar baterias vazias (perigo de explosão e de queimaduras com ácido).</p> <p>Não desmonte nem danifique as baterias. Não deite as baterias no fogo.</p>	<p><b>⚠ ATTENZIONE</b> Utilizzo inappropriato delle batterie! Pericolo di lesioni!</p> <p>Non tentare di riattivare o ricaricare batterie scariche (pericolo di esplosione e corrosione).</p> <p>Non scomporre o danneggiare le batterie. Non gettare le batterie nel fuoco.</p>

S Svenska	DK Dansk	NL Nederlands
<p><b>⚠ VARNING</b> Livsfara om följande säkerhetsanvisningar inte följs!</p> <p>Använd inte produkterna innan du har läst och förstått den dokumentation och de säkerhetsanvisningar som medföljer produkten, och följ alla anvisningar. Kontakta din Rexroth-återförsäljare om dokumentationen inte medföljer på ditt språk.</p> <p>Endast kvalificerad personal får arbeta med drivkomponenterna.</p> <p>Se kapitel 1 i denna dokumentation för närmare beskrivningar av säkerhetsanvisningarna.</p>	<p><b>⚠ ADVARSEL</b> Livsfare ved manglende overholdelse af nedenstående sikkerhedsanvisninger!</p> <p>Tag ikke produktet i brug, før du har læst og forstået den dokumentation og de sikkerhedsanvisninger, som følger med produktet, og overhold de givne anvisninger.</p> <p>Kontakt din Rexroth-forhandler, hvis dokumentationen ikke medfølger på dit sprog.</p> <p>Det er kun kvalificeret personale, der må arbejde på drive components.</p> <p>Nærmere forklaringer til sikkerhedsanvisningerne fremgår af kapitel 1 i denne dokumentation.</p>	<p><b>⚠ WAARSCHUWING</b> Levensgevaar bij niet-naleving van onderstaande veiligheidsinstructies!</p> <p>Stel de producten pas in bedrijf nadat u de met het product geleverde documenten en de veiligheidsinformatie volledig gelezen, begrepen en in acht genomen heeft.</p> <p>Mocht u niet beschikken over documenten in uw landstaal, kunt u contact opnemen met uw plaatselijke Rexroth distributiepartner.</p> <p>Uitsluitend gekwalificeerd personeel mag aan de aandrijvingscomponenten werken.</p> <p>Meer informatie over de veiligheidsinstructies vindt u in hoofdstuk 1 van deze documentatie.</p>
<p><b>⚠ VARNING</b> Hög elektrisk spänning! Livsfara genom elchock!</p> <p>Använd endast drivkomponenterna med fastmonterad skyddsledare.</p> <p>Koppla bort spänningsförsörjningen före arbete på drivkomponenter.</p> <p>Var medveten om kondensatorernas urladdningstid.</p>	<p><b>⚠ ADVARSEL</b> Elektrisk højspænding! Livsfare på grund af elektrisk stød!</p> <p>Drive components må kun benyttes med et fast installeret jordstik.</p> <p>Sørg for at koble spændingsforsyningen fra, inden du rører ved drive components.</p> <p>Overhold kondensatorernes afladningstider.</p>	<p><b>⚠ WAARSCHUWING</b> Hoge elektrische spanning! Levensgevaar door elektrische schok!</p> <p>Bedien de aandrijvingscomponenten uitsluitend met vast geïnstalleerde aardleiding.</p> <p>Schakel voor toegang tot aandrijvingscomponenten de spanningsvoorziening uit.</p> <p>Neem de ontladtid van de condensatoren in acht.</p>
<p><b>⚠ VARNING</b> Farliga rörelser! Livsfara!</p> <p>Uppehåll dig inte inom maskiners och maskindelars rörelseområde.</p> <p>Förhindra att obehöriga personer får tillträde.</p> <p>Innan du börjar arbeta eller vistas inom drivsystemets riskområde måste maskinen vara stillastående.</p>	<p><b>⚠ ADVARSEL</b> Farlige bevægelser! Livsfare!</p> <p>Du må ikke opholde dig inden for maskiners og maskindeles bevægelsesradius.</p> <p>Sørg for, at ingen personer kan få utilsigtet adgang.</p> <p>Stands drevene helt, inden du rører ved drevene eller træder ind i deres fareområde.</p>	<p><b>⚠ WAARSCHUWING</b> Risicovolle bewegingen! Levensgevaar!</p> <p>Houdt u niet op in het bewegingsbereik van machines en machineonderdelen.</p> <p>Voorkom dat personen onbedoeld toegang verkrijgen.</p> <p>Voor toegang tot de gevaarlijke zone moeten de aandrijvingen veilig tot stilstand gebracht zijn.</p>

S Svenska	DK Dansk	NL Nederlands
<p><b>⚠ VARNING</b> Elektromagnetiska/magnetiska fält! Hälsofara för personer med pacemaker, implantat av metall eller hörapparat!</p> <p>Det är förbjudet för ovan nämnda personer (eller kräver överläggning med läkare) att beträda områden där drivkomponenter är monterade och i drift.</p>	<p><b>⚠ ADVARSEL</b> Elektromagnetiske/magnetiske felter! Sundhedsfare for personer med pacemakere, metalliske implantater eller høreapparater!</p> <p>For disse personer er der adgang forbudt eller kun adgang med tilladelse fra læge til de områder, hvor drive components monteres og drives.</p>	<p><b>⚠ WAARSCHUWING</b> Elektromagnetische / magnetische velden! Gevaar voor de gezondheid van personen met pacemakers, metalen implantaten of hoorapparaten!</p> <p>Toegang tot gebieden, waarin aandrijvingscomponenten worden gemonteerd en bediend, is verboden voor voornoemde personen of uitsluitend toegestaan na overleg met een arts.</p>
<p><b>⚠ OBSERVERA</b> Varma ytor (&gt; 60 °C)! Risk för brännskador!</p> <p>Undvik att vidröra metalltytor (t.ex. kylelement). Var medveten om att det tar tid för drivkomponenterna att svalna (minst 15 minuter).</p>	<p><b>⚠ FORSIGTIG</b> Varme overflader (&gt; 60 °C)! Risiko for forbrændinger!</p> <p>Undgå at berøre metaloverflader (f.eks. køleelementer). Overhold drive components nedkølingstid (min. 15 min.).</p>	<p><b>⚠ VOORZICHTIG</b> Hete oppervlakken (&gt; 60 °C)! Verbrandingsgevaar!</p> <p>Voorkom contact met metalen oppervlakken (bijv. Koellichamen). Afkoeltijd van de aandrijvingscomponenten in acht nemen (min. 15 minuten).</p>
<p><b>⚠ OBSERVERA</b> Felaktig hantering vid transport och montering! Skaderisk!</p> <p>Använd passande monterings- och transportanordningar.</p> <p>Använd lämpliga verktyg och personlig skyddsutrustning.</p>	<p><b>⚠ FORSIGTIG</b> Fejlhåndtering ved transport og montering! Risiko for kvæstelser!</p> <p>Benyt egnede monterings- og transportanordninger.</p> <p>Benyt egnet værktøj og personligt sikkerhedsudstyr.</p>	<p><b>⚠ VOORZICHTIG</b> Onjuist gebruik bij transport en montage! Letselgevaar!</p> <p>Gebruik geschikte montage- en transportinrichtingen.</p> <p>Gebruik geschikt gereedschap en een persoonlijke veiligheidsuitrusting.</p>
<p><b>⚠ OBSERVERA</b> Felaktig hantering av batterier! Skaderisk!</p> <p>Försök inte återaktivera eller ladda upp batterier (risk för explosioner och frätskador).</p> <p>Batterierna får inte tas isär eller skadas. Släng inte batterierna i elden.</p>	<p><b>⚠ FORSIGTIG</b> Fejlhåndtering af batterier! Risiko for kvæstelser!</p> <p>Forsøg ikke at genaktivere eller oplade tomme batterier (eksplosions- og ætsningsfare).</p> <p>Undlad at skille batterier ad eller at beskadige dem. Smid ikke batterier ind i åben ild.</p>	<p><b>⚠ VOORZICHTIG</b> Onjuist gebruik van batterijen! Letselgevaar!</p> <p>Probeer nooit lege batterijen te reactiveren of op te laden (explosiegevaar en gevaar voor beschadiging van weefsel door cauterisatie).</p> <p>Batterijen niet demonteren of beschadigen. Nooit batterijen in het vuur werpen.</p>



<b>FIN</b> Suomi	<b>PL</b> Polski	<b>CZ</b> Český
<p><b>VAROITUS</b> Näiden turvaohjeiden noudattamatta jättämisestä on seurauksena hengenvaara!</p> <p>Ota tuote käyttöön vasta sen jälkeen, kun olet lukenut läpi tuotteen mukana toimitetut asiakirjat ja turvallisuusohjeet, ymmärtänyt ne ja ottanut ne huomioon.</p> <p>Jos asiakirjoja ei ole saatavana omalla äidinkiellälläsi, ota yhteyttä asianomaiseen Rexrothin myyntiedustajaan.</p> <p>Käyttölaitteiden komponenttien parissa saa työskennellä ainoastaan valtuutettu henkilöstö.</p> <p>Lisätietoa turvaohjeista löydät tämän dokumentaation luvusta 1.</p>	<p><b>OSTRZEŻENIE</b> Zagrożenie życia w razie nieprzestrzegania poniższych wskazówek bezpieczeństwa!</p> <p>Nie uruchamiać produktów przed uprzednim przeczytaniem i pełnym zrozumieniem wszystkich dokumentów dostarczonych wraz z produktem oraz wskazówek bezpieczeństwa. Należy przestrzegać wszystkich zawartych tam zaleceń.</p> <p>W przypadku braku dokumentów w Państwa języku, prosimy o skontaktowanie się z lokalnym partnerem handlowym Rexroth.</p> <p>Przy zespołach napędowych może pracować wyłącznie wykwalifikowany personel.</p> <p>Blizsze objaśnienia wskazówek bezpieczeństwa znajdują się w Rozdziale 1 niniejszej dokumentacji.</p>	<p><b>VAROVÁNÍ</b> Nebezpečí života v případě nedodržení níže uvedených bezpečnostních pokynů!</p> <p>Před uvedením výrobků do provozu si přečtěte kompletní dokumentaci a bezpečnostní pokyny dodané s výrobkem, pochopte je a dodržujte.</p> <p>Nemáte-li k dispozici podklady ve svém jazyce, obraťte se na příslušného obchodního partnera Rexroth.</p> <p>Na komponentách pohonu smí pracovat pouze kvalifikovaný personál.</p> <p>Podrobnější vysvětlení k bezpečnostním pokynům naleznete v kapitole 1 této dokumentace.</p>
<p><b>VAROITUS</b> Voimakas sähköjännite! Sähköiskun aiheuttama hengenvaara!</p> <p>Käytä käyttölaitteen komponentteja ainoastaan maadoitusjohtimen ollessa kiinteästi asennettuna.</p> <p>Katkaise jännitteensäyöttö ennen käyttölaitteen komponenteille suorittettavien töiden aloittamista.</p> <p>Huomioi kondensaattoreiden purkautusajajat.</p>	<p><b>OSTRZEŻENIE</b> Wysokie napięcie elektryczne! Zagrożenie życia w wyniku porażenia prądem!</p> <p>Zespoły napędu mogą być eksploatowane wyłącznie z zainstalowanym na stałe przewodem ochronnym.</p> <p>Przed uzyskaniem dostępu do podzespołów napędu należy odłączyć zasilanie elektryczne.</p> <p>Zwracać uwagę na czas rozładowania kondensatorów.</p>	<p><b>VAROVÁNÍ</b> Vysoké elektrické napětí! Nebezpečí života při zasazení elektrickým proudem!</p> <p>Komponenty pohonu smí být v provozu pouze s pevně nainstalovaným ochranným vodičem.</p> <p>Než začnete zasahovat do komponent pohonu, odpojte je od elektrického napětí.</p> <p>Dodržujte vybíjecí časy kondenzátorů.</p>
<p><b>VAROITUS</b> Vaarallisia liikkeitä! Hengenvaara!</p> <p>Älä oleskele koneiden tai koneenosien liikealueella.</p> <p>Pidä huolta siitä, ettei muita henkilöitä pääse alueelle vahingossa.</p> <p>Pysäytä käyttölaitteet varmasti ennen vaara-alueelle koskemista tai menemistä.</p>	<p><b>OSTRZEŻENIE</b> Niebezpieczne ruchy! Zagrożenie życia!</p> <p>Nie wolno przebywać w obszarze pracy maszyny i jej elementów.</p> <p>Nie dopuszczać osób niepowołanych do obszaru pracy maszyny.</p> <p>Przed dotknięciem urządzenia/maszyny lub zbliżeniem się do obszaru zagrożenia należy zgodnie z zasadami bezpieczeństwa wyłączyć napędy.</p>	<p><b>VAROVÁNÍ</b> Nebezpečné pohyby! Nebezpečí života!</p> <p>Nezdržujte se v dosahu pohybu strojů a jejich součástí.</p> <p>Zabraňte náhodnému přístupu osob.</p> <p>Před zásahem nebo vstupem do nebezpečného prostoru bezpečně zastavte pohony.</p>

 Suomi	 Polski	 Český
<p><b>VAROITUS</b> Sähkömagneettisia/magneettisia kenttiä! Terveydellisten haittojen vaara henkilöille, joilla on sydämentahdistin, metallinen implantti tai kuulolaite!</p> <p>Yllä mainituilta henkilöiltä on pääsy kielletty alueille, joilla asennetaan tai käytetään käyttölaitteen komponentteja, tai heidän on ensin saatava tähän suostumus lääkäritään.</p>	<p><b>OSTRZEŻENIE</b> Pola elektromagnetyczne / magnetyczne! Zagrożenie zdrowia dla osób z rozrusznikiem serca, metalowymi implantami lub aparatami słuchowymi!</p> <p>Wstęp na teren, gdzie odbywa się montaż i eksploatacja napędów jest dla ww. osób zabroniony względnie dozwolony po konsultacji z lekarzem.</p>	<p><b>VAROVÁNÍ</b> Elektromagnetická/magnetická pole! Nebezpečí pro zdraví osob s kardiostimulátory, kovovými implantáty nebo naslouchadly!</p> <p>Výše uvedené osoby mají zakázán přístup do prostorů, kde jsou montovány a používány komponenty pohonu, resp. ho mají povolen pouze po poradě s lékařem.</p>
<p><b>HUOMIO</b> Kuumia pintoja (&gt; 60 °C)! Palovammojen vaara!</p> <p>Vältä metallipintojen koskettamista (esim. jäähdytyslevyt). Noudata käyttölaitteen komponenttien jäähtymisaikoa (väh. 15 minuuttia).</p>	<p><b>PRZESTROGA</b> Gorące powierzchnie (&gt; 60 °C)! Niebezpieczeństwo poparzenia!</p> <p>Unikać kontaktu z powierzchniami metalowymi (np. radiatorami). Przestrzegać czasów schładzania podzespołów napędów (min. 15 minut).</p>	<p><b>UPOZORNĚNÍ</b> Horké povrchy (&gt; 60 °C)! Nebezpečí popálení!</p> <p>Nedotýkejte se kovových povrchů (např. chladičích těles). Dodržujte dobu ochlazení komponent pohonu (min. 15 minut).</p>
<p><b>HUOMIO</b> Epäasianmukainen käsittely kuljetuksen ja asennuksen yhteydessä! Loukkaantumiswaara!</p> <p>Käytä soveltuvia asennus- ja kuljetuslaitteita.</p> <p>Käytä omia työkaluja ja henkilökohtaisia suojavarusteita.</p>	<p><b>PRZESTROGA</b> Niewłaściwe obchodzenie się podczas transportu i montażu! Ryzyko urazu!</p> <p>Stosować odpowiednie urządzenia montażowe i transportowe.</p> <p>Stosować odpowiednie narzędzia i środki ochrony osobistej.</p>	<p><b>UPOZORNĚNÍ</b> Nesprávné zacházení při přepravě a montáži! Nebezpečí zranění!</p> <p>Používejte vhodná montážní a dopravní zařízení.</p> <p>Používejte vhodné nářadí a osobní ochranné vybavení.</p>
<p><b>HUOMIO</b> Paristojen epäasianmukainen käsittely! Loukkaantumiswaara!</p> <p>Älä yritä saada tyhjiä paristoja toimimaan tai ladata niitä uudelleen (räjähdys- ja syöpymiswaara).</p> <p>Älä hajota paristoja osiin tai vaurioita niitä. Älä heitä paristoja tuelle.</p>	<p><b>PRZESTROGA</b> Niewłaściwe obchodzenie się z bateriami! Ryzyko urazu!</p> <p>Nie próbować reaktywować i nie ładować zużytych baterii (niebezpieczeństwo wybuchu oraz poparzenia żrącą substancją).</p> <p>Nie demontować i nie niszczyć baterii. Nie wrzucać baterii do ognia.</p>	<p><b>UPOZORNĚNÍ</b> Nesprávné zacházení s bateriemi! Nebezpečí zranění!</p> <p>Nepokoušejte se znovu aktivovat nebo dobíjet prázdné baterie (nebezpečí výbuchu a poleptání).</p> <p>Nerozebírejte ani nepoškozujte baterie. Neházejte baterie do ohně.</p>

SLO Slovensko	SK Slovenčina	RO Română
<p><b>⚠ OPOZORILO</b> Življenjska nevarnost pri neupoštevanju naslednjih napotkov za varnost!</p> <p>Izdelke začnite uporabljati šele, ko v celoti preberete, razumete in upošteвате izdelkom priloženo dokumentacijo in varnostne napotke.</p> <p>Če priložena dokumentacija ni na voljo v vašem maternem jeziku, se obrnite na pristojnega distributerja Rexroth.</p> <p>Samo kvalificirano osebje sme delati na pogonskih komponentah.</p> <p>Podrobnejša pojasnila o varnostnih navodilih najdete v poglavju 1 v tej dokumentaciji.</p>	<p><b>⚠ VAROVANIE</b> Nebezpečnostv ohrozenia života pri nedodržavaní nasledujúcich bezpečnostných pokynov!</p> <p>Výrobky uvádzajte do prevádzky až potom, čo ste úplne prečítali, pochopili a zobrali do úvahy podklady a bezpečnostné pokyny dodané s výrobkom.</p> <p>Ak by ste nemali k dispozícii žiadne podklady v jazyku svojej krajiny, obráťte sa prosím na svojho príslušného predajcu Rexroth.</p> <p>Na komponentoch pohonu smie pracovať iba kvalifikovaný personál.</p> <p>Bližšie vysvetlenia k bezpečnostným pokynom zistíte z kapitoly 1 tejto dokumentácie.</p>	<p><b>⚠ AVERTIZARE</b> Pericol de moarte în cazul nerespectării următoarelor instrucțiuni de siguranță!</p> <p>Punerea în funcțiune a produselor trebuie efectuată după citirea, înțelegerea și respectarea documentelor și instrucțiunilor de siguranță, care sunt livrate împreună cu produsele.</p> <p>În cazul în care documentele nu sunt în limba dumneavoastră maternă, vă rugăm să contactați partenerul de vânzări Rexroth.</p> <p>Numai un personal calificat poate lucra cu componentele de acționare.</p> <p>Explicații detaliate privind instrucțiunile de siguranță găsiți în capitolul 1 al acestei documentații.</p>
<p><b>⚠ OPOZORILO</b> Visoka električna napetost! Življenjska nevarnost zaradi električnega udara!</p> <p>Pogonske komponente uporabljajte samo s fiksno nameščenim zaščitnim vodnikom.</p> <p>Pred dostopom do pogonske komponente odklopite napajanje.</p> <p>Upošteвайте čase praznjenja kondenzatorjev.</p>	<p><b>⚠ VAROVANIE</b> Vysoké elektrické napätie! Nebezpečnostv ohrozenia života v dôsledku zásahu elektrickým prúdom!</p> <p>Komponenty pohonu prevádzkujte iba s pevne nainštalovaným ochranným vodičom.</p> <p>Pred prístupom na komponenty pohonu odpojte zdroj napätia.</p> <p>Rešpektujte časy vybitia kondenzátorov.</p>	<p><b>⚠ AVERTIZARE</b> Tensiune electrică înaltă! Pericol de moarte prin electrocutare!</p> <p>Exploatați componentele de acționare numai cu împământarea instalată permanent.</p> <p>Înainte de intervenția asupra componentelor de acționare, deconectați alimentarea cu tensiune electrică.</p> <p>Țineți cont de timpii de descărcare ai condensatorilor.</p>
<p><b>⚠ OPOZORILO</b> Nevarni premiki! Življenjska nevarnost!</p> <p>Ne zadržujte se v območju delovanja strojev.</p> <p>Preprečite nenadzorovan dostop oseb.</p> <p>Pred prijemom ali dostopom v nevarno območje varno zaustavite vse gnane dele.</p>	<p><b>⚠ VAROVANIE</b> Pohyby prinášajúce nebezpečnostv! Nebezpečnostv ohrozenia života!</p> <p>Nezdrživajte sa v oblasti pohybu strojov a častí strojov.</p> <p>Zabráňte nepovolanému prístupu osôb.</p> <p>Pred zásahom alebo prístupom do nebezpečnej oblasti uveďte pohony bezpečne do zastavenia.</p>	<p><b>⚠ AVERTIZARE</b> Mișcări periculoase! Pericol de moarte!</p> <p>Nu staționați în zona de mișcare a mașinilor și a componentelor în mișcare a mașinilor.</p> <p>Împiedicați accesul neintenționat al persoanelor în zona de lucru a mașinilor.</p> <p>Înainte de intervenția sau accesul în zona periculoasă, opriți în siguranță componentele de acționare.</p>

SLO Slovensko	SK Slovenčina	RO Română
<p><b>⚠ OPOZORILO</b>  <b>Elektromagnetna / magnetna polja!</b>  <b>Nevarnost za zdravje za osebe s spodbujevalniki srca, kovinskimi vsadki ali slušnimi aparati!</b></p> <p>Dostop do območij, v katerih so nameščene delujoče pogonske komponente, je za zgoraj navedene osebe prepovedan oz. dovoljen samo po posvetu z zdravnikom.</p>	<p><b>⚠ VAROVANIE</b>  <b>Elektromagnetické/magnetické polia!</b>  <b>Nebezpečenstvo pre zdravie osôb s kardiostimulátormi, kovovými implantátmi alebo načúvacími prístrojmi!</b></p> <p>Prístup k oblastiam, v ktorých sú namontované a prevádzkujú sa komponenty pohonu, je pre hore uvedené osoby zakázaný resp. je dovolený iba po konzultácii s lekárom.</p>	<p><b>⚠ AVERTIZARE</b> Câmpuri  <b>electromagnetice / magnetice! Pericol pentru sănătatea persoanelor cu stimulatori cardiace, implanturi metalice sau aparate auditive!</b></p> <p>Intrarea în zone, în care se montează sau se exploatează componente de acționare, este interzisă pentru persoanele sus numite respectiv este permisă numai cu acordul medicului.</p>
<p><b>⚠ POZOR</b> Vroče površine  <b>(&gt; 60 °C)! Nevarnost opeklin!</b></p> <p>Izogibajte se stiku s kovinskimi površinami (npr. hladilnimi telesmi). Upoštevajte čas hlajenja pogonskih komponent (najm. 15 minut).</p>	<p><b>⚠ UPOZORNENIE</b> Horúce  <b>povrchy (&gt; 60 °C)! Nebezpečenstvo popálenia!</b></p> <p>Zabráňte kontaktu s kovovými povrchmi (napr. chladiacimi telesami). Dodržiavajte čas vychladenia komponentov pohonu (min. 15 minút).</p>	<p><b>⚠ ATENȚIE</b> Suprafețe fierbinți  <b>(&gt; 60 °C)! Pericol de arsuri!</b></p> <p>Nu atingeți suprafețele metalice (de ex. radiatoare de răcire). Respectați timpii de răcire ai componentelor de acționare (min. 15 minute).</p>
<p><b>⚠ POZOR</b> Nestrokovno ravnanje  <b>med transportom in namestitvijo!</b>  <b>Nevarnost poškodb!</b></p> <p>Uporablajte ustrezne pripomočke za nameščanje in transport.</p> <p>Uporabite ustrezno orodje in osebno zaščitno opremo.</p>	<p><b>⚠ UPOZORNENIE</b> Neodborná  <b>manipulácia pri transporte a montáži! Nebezpečenstvo poranenia!</b></p> <p>Používajte vhodné montážne a transportné zariadenia.</p> <p>Používajte vhodné náradie a osobné ochranné prostriedky.</p>	<p><b>⚠ ATENȚIE</b> Manipulare  <b>necorespunzătoare la transport și montaj! Pericol de vătămare!</b></p> <p>Utilizați dispozitive adecvate de montaj și transport.</p> <p>Folosiți instrumente corespunzătoare și echipament personal de protecție.</p>
<p><b>⚠ POZOR</b> Nepravilno ravnanje z  <b>baterijami! Nevarnost poškodb!</b></p> <p>Ne poskušajte ponovno aktivirati ali napolniti praznih baterij (Nevarnost zaradi eksplozij ali jedkanja).</p> <p>Ne razstavljajte ali poškodujte nobenih baterij. Baterij ne mečite v ogenj.</p>	<p><b>⚠ UPOZORNENIE</b> Neodborná  <b>manipulácia s batériami!</b>  <b>Nebezpečenstvo poranenia!</b></p> <p>Nepokúšajte sa reaktivovať alebo nabíjať prázdne batérie (nebezpečenstvo výbuchu a poleptania).</p> <p>Batérie nerozoberajte ani nepoškodujte. Nehádzte batérie do ohňa.</p>	<p><b>⚠ ATENȚIE</b> Manipulare  <b>necorespunzătoare a bateriilor!</b>  <b>Pericol de vătămare!</b></p> <p>Nu încercați să reactivați sau să încărcați bateriile goale (pericol de explozie și pericol de arsuri).</p> <p>Nu dezasamblați și nu deteriorați bateriile. Nu aruncați bateriile în foc.</p>

<b>H</b> Magyar	<b>BG</b> Български	<b>LV</b> Latviski
<p><b>▲ FIGYELMEZTETÉS!</b> Az alábbi biztonsági útmutatások figyelmen kívül hagyása életveszélyes helyzethez vezethet!</p> <p>Üzembe helyezés előtt olvassa el, értelmezze, és vegye figyelembe a csomagban található dokumentumban foglaltakat és a biztonsági útmutatásokat.</p> <p>Amennyiben a csomagban nem talál az Ön nyelvén írt dokumentumokat, vegye fel a kapcsolatot az illetékes Rexroth-képviselővel.</p> <p>A hajtás alkatrészein kizárólag képzett személy dolgozhat.</p> <p>A biztonsági útmutatókkal kapcsolatban további magyarázatot ennek a dokumentumnak az első fejezetében találhat.</p>	<p><b>▲ ПРЕДУПРЕЖДЕНИЕ</b></p> <p>Опасност за живота при неспазване на посочените по-долу инструкции за безопасност!</p> <p>Използвайте продуктите след като сте се запознали подробно с приложената към продукта документация и указания за безопасност, разбрали сте ги и сте се съобразили с тях.</p> <p>Ако текстът не е написан на Вашия език, моля обърнете се към Вашия компетентен търговски представител на Rexroth.</p> <p>Със задвижващите компоненти трябва да работи само квалифициран персонал.</p> <p>Подробни пояснения към инструкциите за безопасност можете да видите в Глава 1 на тази документация.</p>	<p><b>▲ BRĪDINĀJUMS</b> Turpinājumā doto drošības norādījumu neievērošana var apdraudēt dzīvību!</p> <p>Sāciet lietot izstrādājumu tikai pēc tam, kad esat pilnībā izlasījuši, sapratuši un nēmuši vērā kopā ar izstrādājumu piegādātos dokumentus.</p> <p>Ja dokumenti nav pieejami Jūsu valsts valodā, vērsieties pie pilnvarotā Rexroth izplatītāja.</p> <p>Darbus pie piedziņas komponentiem drīkst veikt tikai kvalificēts personāls.</p> <p>Detalizētus paskaidrojumus attiecībā uz drošības norādījumiem skatiet šī dokumenta 1. nodaļā.</p>
<p><b>▲ FIGYELMEZTETÉS!</b> Magas elektromos feszültség! Életveszély áramütés miatt!</p> <p>A hajtás alkatrészeit csak véglegesen telepített védővezetővel üzemeltesse!</p> <p>Mielőtt hozzányúl a hajtás alkatrészeihez, kapcsolja ki az áramellátást.</p> <p>Ügyeljen a kondenzátorok kisülési idejére!</p>	<p><b>▲ ПРЕДУПРЕЖДЕНИЕ</b> Високо електрическо напрежение! Опасност за живота от удар от електрически ток!</p> <p>Работете със задвижващите компоненти само при здраво закрепен заземяващ проводник.</p> <p>Преди работа по задвижващите компоненти, изключете захранващото напрежение.</p> <p>Обърнете внимание на времето за разреждане на кондензаторите.</p>	<p><b>▲ BRĪDINĀJUMS</b> Augsts elektriskais spriegums! Dzīvības apdraudējums elektriskā trieciena dēļ!</p> <p>Piedziņas komponentus darbiniet tikai ar fiksēti uzstādītu zemējumvadu.</p> <p>Pirms darba pie piedziņas komponentiem atslēdziet elektroapgādi.</p> <p>Nemiet vērā kondensatoru izlādes laikus.</p>
<p><b>▲ FIGYELMEZTETÉS!</b> Veszélyes mozgás! Életveszély!</p> <p>Ne tartózkodjon a gépek és a gépalkatrészek mozgási területén belül!</p> <p>Illetéktelen személyeket ne engedjen a gép közelébe!</p> <p>Mielőtt beavatkozik, vagy a veszélyes zónába belép a hajtásokat biztonságosan állítsa le.</p>	<p><b>▲ ПРЕДУПРЕЖДЕНИЕ</b> Опасни движения! Опасност за живота!</p> <p>Не стойте в обсега на движение на машините и частите на машините.</p> <p>Не допускайте непреднамерен достъп на хора.</p> <p>Преди работа или влизане в опасната зона, спрете наредно приводния механизъм.</p>	<p><b>▲ BRĪDINĀJUMS</b> Bīstamas kustības! Dzīvības apdraudējums!</p> <p>Neuzturieties mašīnu un mašīnas detaļu kustību zonā.</p> <p>Novērsiet nepiederošu personu piekļūšanu.</p> <p>Pirms darba bīstamajās zonās pilnībā apstādiniet piedziņu.</p>

<b>H</b> Magyar	<b>BG</b> Български	<b>LV</b> Latviski
<p><b>▲ FIGYELMEZTETÉS!</b> Elektromágneses / mágneses mező! Káros hatással lehet a szívritmus-szabályozó készülékekkel, fémbeültetéssel vagy hallókészülékkel rendelkezők egészségére!</p> <p>Azokra a területekre, ahol hajtások alkatrészeit szerelik és üzemeltetik, a fent említett személyeknek tilos a belépés, illetve csak orvosi konzultációt követően szabad az adott területekre lépniük.</p>	<p><b>▲ ПРЕДУПРЕЖДЕНИЕ</b> Електромагнитни / магнитни полета! Опасност за здравето на хора със сърдечни стимулатори, метални импланти или слухови апарати!</p> <p>Достъпът за гореспоменатите лица до зони, в които ще се монтира и ще работят задвижващи компоненти се забранява, или разрешава само след консултация с лекар.</p>	<p><b>▲ BRĪDINĀJUMS</b> Elektromagnētiskais / magnētiskais lauks! Veselības apdraudējums personām ar sirds stimulatoriem, metāliskiem implantiem vai dzirdes aparātiem!</p> <p>Tuvošanās zonām, kurās tiek montēti un darbināti piedziņas komponenti, iepriekš minētajām personām ir aizliegta, respektīvi, atļauta tikai pēc konsultēšanās ar ārstu.</p>
<p><b>▲ VIGYÁZAT!</b> Forró felületek (&gt; 60 °C)! Égésveszély!</p> <p>Ne érjen hozzá fémfelületekhez (pl. hűtőtestekhez)! Vegye figyelembe a hajtás alkatrészeinek kihűlési idejét (min. 15 perc)!</p>	<p><b>▲ ВНИМАНИЕ</b> Горещи повърхности (&gt; 60 °C)! Опасност от изгаряне!</p> <p>Не докосвайте метални повърхности (например радиатори). Съблюдавайте времето на охлаждане на задвижващите компоненти (мин. 15 минути).</p>	<p><b>▲ UZMANĪBU</b> Karstas virsmas (&gt; 60 °C)! Apdedzināšanās risks!</p> <p>Neskarieties pie metāliskām virsmām (piemēram, dzesētāja). Ļaujiet piedziņas komponentiem atdzist (min. 15 minūtes).</p>
<p><b>▲ VIGYÁZAT!</b> Szakszerűtlen kezelés szállításkor és szereléskor! Sérülésveszély!</p> <p>A megfelelő beszerelési és szállítási eljárásokat alkalmazza!</p> <p>Használjon megfelelő szerszámokat és személyes védőfelszerelést!</p>	<p><b>▲ ВНИМАНИЕ</b> Неправилно боравене по време на транспорт и монтаж! Опасност от нараняване!</p> <p>Използвайте подходящо монтажно и транспортно оборудване.</p> <p>Използвайте подходящи инструменти и лични предпазни средства.</p>	<p><b>▲ UZMANĪBU</b> Nepareizi veikta transportēšana un montāža! Traumu gūšanas risks!</p> <p>Izmantojiet piemērotas montāžas un transportēšanas ierīces.</p> <p>Izmantojiet piemērotus instrumentus un individuālos aizsardzības līdzekļus.</p>
<p><b>▲ VIGYÁZAT!</b> Akkumulátorok szakszerűtlen kezelése! Sérülésveszély!</p> <p>Üres akkumulátorokat ne aktiváljon újra, illetve ne töltsön fel (robbanás- és marásveszély)!</p> <p>Az akkumulátorokat ne szedje szét, és ne rongálja meg! Az akkumulátort ne dobja tűzbe!</p>	<p><b>▲ ВНИМАНИЕ</b> Неправилно боравене с батерии! Опасност от нараняване!</p> <p>Не се опитвайте да активирате отново или да зареждате разредени батерии (Опасност от експлозия и напръскване с агресивен агент).</p> <p>Не разлбявайте и не повреждайте батерии. Не хвърляйте батерии в огън.</p>	<p><b>▲ UZMANĪBU</b> Nepareiza bateriju lietošana! Traumu gūšanas risks!</p> <p>Nemēģiniet no jauna aktivizēt vai uzlādēt tukšas baterijas (eksplodējuma un ķīmisko apdegumu draudi).</p> <p>Neizjauciet un nesabojājiet baterijas. Nemetiet baterijas uguni.</p>

<b>LT</b> Lietuviškai	<b>EST</b> Eesti	<b>GR</b> Ελληνικά
<p><b>▲ ISPĖJIMAS</b> Pavojus gyvybei nesilaikant toliau pateikiamų saugumo nurodymų!</p> <p>Naudokite gaminį tik kruopščiai perskaitę prie jo pridėtus aprašus, saugumo nurodymus. Susipažinkite su jais ir vadovaukitės naudodami gaminį.</p> <p>Jei Jūs negavote aprašo gimtąja kalba, kreipkitės į įgaliotus Rexroth atstovus.</p> <p>Prie pavaros komponentų leidžiama dirbti tik kvalifikuotam personalui.</p> <p>Išsamesnius saugumo nurodymų paaiškinimus rasite šios dokumentacijos 1 skyriuje.</p>	<p><b>▲ HOIATUS</b> Alljärgnevat ohutusjuhiste eiramine on eluohhtlik!</p> <p>Võtke tooted käiku alles siis, kui olete toodetega kaasasolevad materjalid ning ohutusjuhised täielikult läbi lugenud, neist aru saanud ja neid järginud.</p> <p>Kui Teil puuduvad emakeelsed materjalid, siis pöörduge Rexrothi kohaliku müügiesinduse poole.</p> <p>Ajamikomponentidega tohib töötada üksnes kvalifitseeritud personal.</p> <p>Täpsemaid selgitusi ohutusjuhiste kohta leiate käesoleva dokumentatsiooni peatükist 1.</p>	<p><b>▲ ΠΡΟΕΙΔΟΠΟΙΗΣΗ</b> Κίνδυνος θανάτου σε περίπτωση μη συμμόρφωσης με τις παρακάτω οδηγίες ασφαλείας!</p> <p>Θέστε το προϊόν σε λειτουργία αφού διαβάσετε, κατανοήσετε και λάβετε υπόψη το σύνολο των οδηγιών ασφαλείας που το συνοδεύουν.</p> <p>Εάν δεν υπάρχει τεκμηρίωση στη γλώσσα σας, απευθυνθείτε σε εξουσιοδοτημένο αντιπρόσωπο της Rexroth.</p> <p>Μόνο εξειδικευμένο προσωπικό επιτρέπεται να χειρίζεται στοιχεία μετάδοσης κίνησης.</p> <p>Περαιτέρω επεξηγήσεις των οδηγιών ασφαλείας διατίθενται στο κεφάλαιο 1 της παρούσας τεκμηρίωσης.</p>
<p><b>▲ ISPĖJIMAS</b> Aukšta elektros įtampa! Pavojus gyvybei dėl elektros smūgio!</p> <p>Pavaros komponentus eksploatuokite tik su fiksuotai instaliuotu apsauginiu laidu.</p> <p>Prieš priedami prie pavaros komponentų išjunkite maitinimo įtampą.</p> <p>Atsižvelkite į kondensatorių išsikrovimo trukmę.</p>	<p><b>▲ HOIATUS</b> Kõrge elektripingel! Eluohhtlik elektrilöögi tõttu!</p> <p>Käitage ajamikomponente üksnes püsivalt installeeritud maandusega.</p> <p>Lülitage enne ajamikomponentidega tööde alustamist toitepinge välja.</p> <p>Järgige kondensaatorite mahalaadumisaegu.</p>	<p><b>▲ ΠΡΟΕΙΔΟΠΟΙΗΣΗ</b> Υψηλή ηλεκτρική τάση! Κίνδυνος θανάτου από ηλεκτροπληξία!</p> <p>Θέτετε σε λειτουργία τα στοιχεία μετάδοσης κίνησης μόνο εφόσον έχει τοποθετηθεί καλά προστατευτικός αγωγός γείωσης.</p> <p>Πριν από οποιαδήποτε παρέμβαση, αποσυνδέστε την τροφοδοσία των στοιχείων μετάδοσης κίνησης.</p> <p>Λάβετε υπόψη τους χρόνους αποφόρτισης των πυκνωτών.</p>
<p><b>▲ ISPĖJIMAS</b> Pavojingi judesiai! Pavojus gyvybei!</p> <p>Nebūkite mašinų ar jų dalių judėjimo zonoje.</p> <p>Neleiskite netyčia patekti asmenims.</p> <p>Prieš patekdami į pavojaus zoną saugiai išjunkite pavaras.</p>	<p><b>▲ HOIATUS</b> Ohtlikud liikumised! Eluohhtlik!</p> <p>Ärge viibige masina ja masinaosade liikumispiirkonnas.</p> <p>Tõkestage inimeste ettekavatsematu sisenemine masina ja masinaosade liikumispiirkonda.</p> <p>Tagage ajamite turvaline seiskamine enne ohupiirkonda juurdepääsu või sisenemist.</p>	<p><b>▲ ΠΡΟΕΙΔΟΠΟΙΗΣΗ</b> Επικίνδυνες τάσεις! Κίνδυνος θανάτου!</p> <p>Μην στέκεστε στην περιοχή κίνησης μηχανημάτων και εξαρτημάτων.</p> <p>Αποτρέπετε την τυχαία είσοδο ατόμων.</p> <p>Πριν από την παρέμβαση ή πρόσβαση στην περιοχή κινδύνου, μερμνήστε για την ασφαλή ακινητοποίηση των συστημάτων μετάδοσης κίνησης.</p>

<b>LT</b> Lietuviškai	<b>EST</b> Eesti	<b>GR</b> Ελληνικά
<p><b>⚠️ JSPĖJIMAS</b> Elektromagnetiniai / magnetiniai laukai! Pavojus asmenų su širdies stimuliatoriais, metaliniais implantais arba klausos aparatais sveikatai!</p> <p>Prieiga prie zonų, kuriose montuojami ir eksploatuojami pavaros komponentai, aukščiau nurodytiems asmenims yra draudžiama arba leistina tik pasitarus su gydytoju.</p>	<p><b>⚠️ HOIATUS</b> Elektromagnetilised / magnetilised väljad! Terviseohtlik südamestimulaatorite, metallimplantaatide ja kuulimisseadmetega inimestele!</p> <p>Sisenemine piirkondadesse, kus toimub ajamikomponentide monteerimine ja käitamine, on ülalnimetatud isikutele keelatud või lubatud üksnes pärast arstiga konsulteerimist.</p>	<p><b>⚠️ ΠΡΟΕΙΔΟΠΟΙΗΣΗ</b> Ηλεκτρομαγνητικά/μαγνητικά πεδία! Κίνδυνος για την υγεία ατόμων με καρδιακούς βηματοδότες, μεταλλικά εμφυτεύματα ή συσκευές ακοής!</p> <p>Η είσοδος σε περιοχές όπου πραγματοποιείται συναρμολόγηση και λειτουργία στοιχείων μετάδοσης κίνησης απαγορεύεται στα προαναφερθέντα άτομα, εκτός αν τους έχει δοθεί σχετική άδεια κατόπιν συνεννόησης με γιατρό.</p>
<p><b>⚠️ PERSPĖJIMAS</b> Karšti paviršiai (&gt; 60 °C)! Nudėgimo pavojus!</p> <p>Venkite liesti metalinius paviršius (pvz., radiatorių). Išlaikykite pavaros komponentų atvėsimą trukmę (bent 15 minučių).</p>	<p><b>⚠️ ETTEVAATUST</b> Kuumad välispinnad (&gt; 60 °C)! Põletusoht!</p> <p>Vältige metalsete välispindade (nt radiaatorid) puudutamist. Pidage kinni ajamikomponentide mahajahtumisajast (vähemalt 15 minutit).</p>	<p><b>⚠️ ΠΡΟΣΟΧΗ</b> Καυτές επιφάνειες (&gt; 60 °C)! Κίνδυνος εγκαύματος!</p> <p>Αποφύγετε την επαφή με μεταλλικές επιφάνειες (π.χ. μονάδες ψύξης). Λάβετε υπόψη το χρόνο ψύξης των στοιχείων μετάδοσης κίνησης (τουλάχιστον 15 λεπτά).</p>
<p><b>⚠️ PERSPĖJIMAS</b> Netinkamas darbas transportuojant ir montuojant! Susižalojimo pavojus!</p> <p>Naudokite tinkamus montavimo ir transportavimo įrenginius.</p> <p>Naudokite tinkamus įrankius ir asmens saugos priemones.</p>	<p><b>⚠️ ETTEVAATUST</b> Asjatundmatu käsitsemise transportimisel ja montaažil! Vigastusoht!</p> <p>Kasutage sobivaid montaaži- ja transpordiseadiseid.</p> <p>Kasutage sobivaid tööriistu ja isiklikku kaitsevarustust.</p>	<p><b>⚠️ ΠΡΟΣΟΧΗ</b> Ακατάλληλος χειρισμός κατά τη μεταφορά και συναρμολόγηση! Κίνδυνος τραυματισμού!</p> <p>Χρησιμοποιείτε κατάλληλους μηχανισμούς συναρμολόγησης και μεταφοράς.</p> <p>Χρησιμοποιείτε κατάλληλα εργαλεία και ατομικό εξοπλισμό προστασίας.</p>
<p><b>⚠️ PERSPĖJIMAS</b> Netinkamas darbas su baterijomis! Susižalojimo pavojus!</p> <p>Nebandykite tuščių baterijų reaktyvuoti arba įkrauti (sprogimo ir išėdinimo pavojus).</p> <p>Neardykite ir nepažeiskite baterijų. Nemeskite baterijų į ugnį.</p>	<p><b>⚠️ ETTEVAATUST</b> Patareide asjatundmatu käsitsemise! Vigastusoht!</p> <p>Ärge üritage kunagi tühje patareid reaktiveerida või täis laadida (plahvatus- ja söövitusoht).</p> <p>Ärge demonteerige ega kahjustage patareid. Ärge visake patareid tulle.</p>	<p><b>⚠️ ΠΡΟΣΟΧΗ</b> Ακατάλληλος χειρισμός μπαταριών! Κίνδυνος τραυματισμού!</p> <p>Μην επιδιώκετε να ενεργοποιήσετε ξανά ή να φορτίσετε κενές μπαταρίες (κίνδυνος έκρηξης και διάβρωσης).</p> <p>Μην διαλύετε ή καταστρέφετε τις μπαταρίες. Μην απορρίπτετε τις μπαταρίες στη φωτιά.</p>



CN 中文

**警告** 如果不按照下述指定的安全说明使用，将会导致人身伤害！

在没有阅读，理解随本产品附带的文件并熟知正当使用前，不要安装或使用本产品。

如果没有您所在国家官方语言文件说明，请与 Rexroth 销售伙伴联系。

只允许有资格人员对驱动器部件进行操作。

安全说明的详细解释在本文档的第一章。

**警告** 高压！电击导致生命危险！

只有在安装了永久良好的设备接地导线后才可以对驱动器的部件进行操作。

在接触驱动器部件前先将驱动器部件断电。

确保电容放电时间。

**警告** 危险运动！生命危险！

保证设备的运动区域内和移动部件周围无障碍物。

防止人员意外进入设备运动区域内。

在接近或进入危险区域之前，确保传动设备安全停止。

**警告** 电磁场/磁场！对佩戴心脏起搏器、金属植入物和助听器的人员会造成严重的人身伤害！

上述人员禁止进入安装及运行的驱动器区域，或者必须先咨询医生。

**小心** 热表面（大于 60 度）！灼伤风险！

不要触摸金属表面（例如散热器）。驱动器部件断电后需要时间进行冷却（至少 15 分钟）。

**小心** 安装和运输不当导致受伤危险！当心受伤！

使用适当的运输和安装设备。

使用适合的工具及用适当的防护设备。

**小心** 电池操作不当！受伤风险！

请勿对低电量电池重新激活或重新充电（爆炸和腐蚀的危险）。

请勿拆解或损坏电池。请勿将电池投入明火中。



# Table of Contents

	Page
<b>1 About this documentation.....</b>	<b>1</b>
1.1 Validity of the documentation .....	1
1.2 Additional documentation .....	1
1.3 Presentation of information.....	1
<b>2 Safety instructions .....</b>	<b>4</b>
2.1 About this product .....	4
2.2 Intended use.....	4
2.3 Unintended use.....	4
2.4 Qualification of personnel.....	5
2.5 General safety instructions.....	5
2.6 Product- and technology-dependent safety instructions .....	5
2.6.1 Protection from electric voltage.....	5
2.6.2 Protection from mechanical danger.....	6
2.6.3 Protection against magnetic and electromagnetic fields.....	6
2.6.4 Protection against burns.....	6
<b>3 Scope of delivery .....</b>	<b>8</b>
<b>4 About this product .....</b>	<b>9</b>
4.1 Safety instructions on the product.....	9
4.2 Features and functions .....	9
4.2.1 Basic data.....	9
4.2.2 Mechanical interfaces.....	11
4.2.3 Thermal motor protection.....	12
4.2.4 Motor cooling.....	13
Self-cooling (IC410) .....	13
Forced ventilation (IC416).....	14
Water cooling (IC3W7).....	15
Cooling system.....	15
Coolants.....	15
4.2.5 Encoder.....	18
Technical data of encoder.....	18
4.2.6 Degree of protection.....	19
4.2.7 Output shaft balancing and extension elements.....	19
Shaft end.....	19
Balancing.....	20

	Page
Attachment of drive elements.....	21
4.2.8 Holding brakes.....	23
Technical data holding brakes.....	24
Energy saving function for holding brakes.....	25
Safety instructions holding brakes.....	25
Holding brake – Commissioning and maintenance instructions .....	26
4.2.9 Flange exactness.....	27
Concentricity tolerance of the shaft end.....	27
Concentricity and alignment.....	28
4.2.10 Vibration behavior .....	28
4.2.11 Bearing.....	28
Bearing service life.....	29
Explanation of radial and axial force .....	30
4.2.12 Frame size, installation type.....	30
4.2.13 Coating .....	31
4.2.14 Air-pressure connector kit.....	32
4.2.15 Noise emission .....	33
4.3 Product identification .....	34
4.3.1 Type code .....	34
4.3.2 Type plate .....	34
<b>5 Operating conditions and handling.....</b>	<b>36</b>
5.1 Ambient conditions in operation, at transport and storage.....	36
5.2 Ambient temperature und installation altitude in operation.....	36
5.3 De-rating in case of deviating ambient conditions.....	37
5.4 Vibration load during operation.....	39
5.5 Shock load during transport und storage.....	40
5.6 Transport (shipping).....	40
5.7 Transport with lifting devices.....	41
5.8 Storage.....	42
5.9 Operation on foreign converters.....	44
<b>6 Assembly .....</b>	<b>46</b>
6.1 Motor assembly.....	46
6.1.1 Flange assembly.....	46
6.1.2 Attaching transmission elements.....	46
6.2 Connecting the electric supply.....	48
6.2.1 Safety.....	48
6.2.2 MS2N Electrical connection "S".....	50

	Page
6.2.3 MS2N Electrical connection "D".....	52
6.2.4 MS2N Electrical connection "U".....	54
6.2.5 MS2N Electrical connection "V".....	56
6.2.6 MS2N Electrical connection "A" or "B".....	58
6.2.7 MS2N Electrical connection "T".....	60
6.2.8 MS2N Electrical connection "C".....	64
6.2.9 SpeedCon connectors.....	66
6.2.10 Plug-in connector with threaded connection.....	67
6.2.11 Terminal boxes.....	68
6.2.12 Fan unit .....	70
6.2.13 Ground connection.....	72
6.3 Connection water cooling .....	74
6.4 Sealing air connection .....	76
<b>7 Commissioning and operation.....</b>	<b>77</b>
7.1 Commissioning.....	77
7.2 Operation.....	78
<b>8 Maintenance and repair .....</b>	<b>79</b>
8.1 Maintenance .....	79
8.2 Service repair, maintenance and spare parts.....	82
<b>9 Disassembly and exchange .....</b>	<b>83</b>
9.1 Tools required .....	83
9.2 Exchanging the motor.....	83
9.3 Preparing storage .....	84
<b>10 Environmental protection and disposal .....</b>	<b>85</b>
<b>11 Troubleshooting .....</b>	<b>87</b>
11.1 Troubleshooting procedure .....	87
<b>12 Technical data.....</b>	<b>88</b>
<b>13 Appendix.....</b>	<b>89</b>
13.1 EU-Declaration of conformity .....	89
13.2 UL / CSA.....	92
13.3 China RoHS 2.....	92

	Page
<b>Index.....</b>	<b>93</b>

# 1 About this documentation

## Editions of this documentation

Edition	Release date	Remark
03	2018-04	Revision according to project planning manual edition 03, water cooling
02	2016-06	Revision according to project planning manual edition 01
01	2015-05	First edition corrected
01	2015-03	First edition

Tab. 1-1: Record of revisions

## 1.1 Validity of the documentation

This documentation is valid for Rexroth housing motors of the MS2N series and must be observed by assemblers, operators, service engineers and facility operators.

## 1.2 Additional documentation

Operate this product only, if you have the following documentation available. You must understand and observe this documentation.

	Title	Document type	Document number
	Rexroth IndraDyn S Synchronous Motors MS2N	Project planning manual	DOK-MOTOR*-MS2N*****-PRxx-xx-P

Tab. 1-2: Additional documentation

## 1.3 Presentation of information

### Safety instructions

The safety instructions in this documentation include signal words (danger, warning, caution, note) and a signal symbol (acc. to ANSI Z535.6-2006).

The signal word is intended to draw your attention to the safety instructions and describes the seriousness of the danger. The warning triangle with exclamation mark indicates the danger for persons.

 **DANGER**

Non-compliance with this safety instructions **will** result in death or severe personal injury.

## WARNING

Non-compliance with this safety instructions **can** result in death or severe personal injury.

## CAUTION









Non-compliance with this safety instructions **can** result in moderate or minor personal injury.

## NOTICE

Non-compliance with this safety instructions **can** result in material damage.

### Safety sign

In the documentation, the following internationally standardized safety signs and graphic symbols are used. The table contains the significance of the signs.

Safety sign	Significance
	Warning against dangerous electric voltage
	Warning against hot surfaces
	Warning against rotating machine parts
	Warnung vor schwebender Last
	Electrostatic sensitive devices
	No admittance for persons with pacemaker or implanted defibrillators
	Do not carry along metal parts or clocks
	Hammer scales are forbidden

Tab. 1-3: Meaning of safety signs



## Markup

The following markups are used for a user-friendly text information representation.

 Reference to supplementary documentation

---

 This note gives important information, which must be observed.

---

- Listings on the first level contain a bullet point
  - Listings on the second level contain a dash
- 1. Handling instructions are specified in numbered lists. Please comply with the order of the handling instructions.

## 2 Safety instructions

### 2.1 About this product

Observe the general safety notes in this chapter and the safety instructions in this documentation. Therewith, you avoid personal danger, damage and errors.



This operating instruction must be stored and transferred in case of sale during the complete product lifetime.

### 2.2 Intended use

Prerequisites for proper and safe use of the motors are proper transport, appropriate storage, proper assembly and connection, careful maintenance, operation and overhaul.

The motors have been designed for installation in industrial machinery. The motors have been designed and manufactured in compliance with the EU directives and harmonized standards specified in the following.

#### Standards

EN 60034-1	Rating and performance
EN 60034-5	Degree of protection

#### Directives

2014/35/EU	Low voltage directive
------------	-----------------------

The machine manufacturer must evaluate the electric and mechanic safety as well as environmental influences in the assembled state of the machine according to the Machine Directive 2006/42/EC and DIN EN 60204-1 (safety of machines).

The electrical installation must comply with the protection requirements of EMC Directive 2014/30/EU. The plant manufacturer is responsible for appropriate installation (for example: physical separation of signal and power cables, using shielded cables, ...). The EMC instructions of the converter manufacturer must be observed.

The machine may not be commissioned before conformity with these directives has been confirmed.

### 2.3 Unintended use

Any use of the MS2N motors outside of the specified fields of application or under operating conditions and technical data other than those specified in this documentation is considered to be "inappropriate use".

Unless explicitly provided for this purpose, the motors may not be used in explosion-hazardous areas.

Direct operation on the three-phase network is forbidden.

## 2.4 Qualification of personnel

For the purpose of this manual, qualified personnel means persons who are familiar with transporting, installing, mounting, commissioning and operating the components of the electrical drive and control system and the associated hazards and have an appropriate qualification for their job.

All persons working on, with or in the vicinity of an electrical system must be informed of the relevant safety requirements, safety guidelines and internal instructions (EN 50110-1).

## 2.5 General safety instructions

Do not install or operate motors or components of the electric drive and control system before you have not carefully read all delivered documents.

Please observe the particular applicable national, local and system-specific regulations, the safety instructions in the documentation and the warning and informative labels on the motors.

**Improper use of the motors and failure to follow the safety instructions in this document may result in material damage, personal injury, electric shock or, in extreme cases, to death!**

In the case of damage due to non-observance of the safety notes, Bosch Rexroth assumes no liability.

Applications for functional safety are only allowed if the motors have the SI-sign on the rating plate.

## 2.6 Product- and technology-dependent safety instructions

### 2.6.1 Protection from electric voltage

**Work required on the electric system may only be carried out by skilled electricians. Tools for electricians (VDE tools) are absolutely necessary.**

Before working:

1. Enable.
2. Secure against reactivation.
3. Ensure de-energization.
4. Ground and short-circuit.
5. Cover or shield any adjacent live parts.

After completing the job, cancel the measures in reverse order.

**Dangerous voltage occurs during operation! Danger to life, risk of injury by electric shock!**

- Before start-up, connect the protective conductors on all electric components according to the connection plan.

- Operation, even for short measuring purposes is only allowed with fixed connected protective conductor on the specified points of the components.

## 2.6.2 Protection from mechanical danger

**Dangerous movements! Danger to life, risk of injury, heavy injury or material damage.**

- Do not stay within the motion zone of the machine. Avoid unauthorized access into the danger zone.
- Additionally secure vertical axes to prevent them from sinking or descending after having shutdown the motor, for instance as follows:
  - Mechanically lock the vertical axis,
  - providing an external braking / catching / clamping device, or
  - Ensure sufficient weight compensation of the axes.

Only using the serially delivered **motor holding brake** or an external holding brake activated by the drive controller **is not suitable for personal protection!**

**Rotating parts! Danger to life, risk of injury, heavy injury or material damage.**

- Secure key and/or transmission elements against ejection.
- Install covers on dangerous rotating machine parts before start-up.

## 2.6.3 Protection against magnetic and electromagnetic fields

Magnetic and electromagnetic fields are created in the direct environment of live conductors or permanent magnets of electro motors and are a serious danger for persons.

**Strong magnetic and electromagnetic fields pose a health hazard for persons with heart pacemakers, metallic implants and hearing aids in the direct environment of motor components!**

- Persons with heart pacemakers and metallic implants are not allowed to approach or handle these motor components.

**Crushing hazard of fingers and hands due to strong attractive forces of the magnets!**

- Handle only with protective gloves.

**Risk of destruction of sensitive parts!**

- Keep watches, credit cards, check cards and identity cards and all ferromagnetic metal parts, such as iron, nickel and cobalt away from permanent magnets.

## 2.6.4 Protection against burns

**Risk of burns due to hot motor surfaces!**

- Avoid contact with hot motor surfaces. **Temperatures may rise over 60 °C.**

- Allow the motors to cool down long enough before touching them.
- Temperature-sensitive components may not come into contact with the motor surface. Ensure appropriate mounting distance of connection cables and other components.

### **3 Scope of delivery**

The scope of delivery of an IndraDyn housing motor contains:



- Motor in original package
- Additional rating plate
- Safety notes and instructions on use
- Optional connecting accessories for motors with terminal box
- Protective covers for output shaft, plug connections and coolant connections of water-cooled motors.
- Accompanying papers

At delivery, immediately check if the supplied components match with the delivery note. The forwarder must be promptly informed of any damage on the packaging and goods, which is detected on delivery. Start-up of damaged goods is prohibited.

## 4 About this product

### 4.1 Safety instructions on the product

Please note the safety and prohibitive sign on the motor. The sign significance is explained in the following.

Safety sign	Meaning
	<p><b>Hot surfaces with temperatures over 60 °C may cause burns</b></p> <p>Let the motors cool down before working on the motors or in close proximity to the motors. The thermal time constant stated in the technical data is a measure for the cooling time. Cooling down can require up to 140 minutes.</p> <ul style="list-style-type: none"> <li>- Wear safety gloves</li> <li>- Do not work on hot surfaces.</li> </ul>
	<p><b>Motor damage due to strikes onto the motor shaft</b></p> <p>Do not strike the shaft end and do not exceed the allowed axial and radial forces of the motor.</p>

Tab. 4-1: Safety sign on the product

### 4.2 Features and functions

The motors of the MS2N series are three-phase synchronous motors which are energized by a permanent magnet and are suitable for operation on converters or inverters of Bosch Rexroth.

#### 4.2.1 Basic data

Product	3- PM motor
Type	MS2N
Ambient temperature during operation	0 ... 40 °C
Protection class (EN 60034-5)	IP64 without shaft sealing ring IP65 with shaft sealing ring
Cooling mode (EN 60034-6)	IC410, Self-cooling IC416, Forced ventilation 230 V / 115 V, Air flow direction NDE ⇒ DE, Thermal protection (no circuit with external motor protection necessary) IC3W7, Water cooling
Motor design (EN 60034-7)	IM B5
Coating	Varnish RAL 9005
Flange	similar to DIN 42948

<b>Shaft end</b>	Cylindrical (DIN 748 part 3), centering hole with thread "DS" (DIN 332 part 2), Optional with keyway (half key balancing according to DIN ISO 21940-32)								
<b>Concentricity, run-out, alignment</b>	Standard tolerance N (DIN 42955) Optional tolerance R (DIN 42955)								
<b>Oscillating quantity level</b>	Level A (EN 60034-14) up to the rated speed								
<b>Installation altitude</b>	0 ... 1000 m above sea level (without derating)								
<b>Sound pressure level</b>	MS2N03... MS2N10: 75 dB(A) +3 dB(A)								
<b>Thermal class</b>	155 (F) (EN 60034-1)								
<b>Encoder system</b>	<p><b>Basic performance HIPERFACE®</b> Capacitive absolute value encoder, sin/cos 1Vss, 16 signal periods as single or multi-turn variant</p> <p><b>Standard performance HIPERFACE®</b> Optical absolute value encoder, sin/cos 1Vss, 128 bit, digital in single or multi-turn variant</p> <p><b>Advanced performance ACURO®link</b> Optical absolute value encoder 20 bit, digital in single or multi-turn variant</p> <p><b>High performance ACURO®link</b> Optical absolute value encoder 24 bit, digital in Single- or Multiturnausführung</p>								
<b>Electrical connection</b>	<p><b>Single cable connection</b> with circular connector M23, rotatable, quick lock SPEEDCON®</p> <p><b>Double cable connection</b> with Power connectors M17, M23, M40 (rotatable, quick lock SPEEDCON®), M58 or terminal boxes Encoder connector M17, rotatable, quick lock SPEEDCON®</p>								
<b>Holding brake (option)</b>	Electrically released $U_N$ 24V DC ( $\pm 10\%$ )								
<b>Motor ends</b>	 <table style="display: inline-table; vertical-align: top; margin-left: 20px;"> <tr> <td>DE</td> <td>Drive End, A-side</td> </tr> <tr> <td>NDE</td> <td>Non Drive End, B-side</td> </tr> <tr> <td>L</td> <td>Left, links</td> </tr> <tr> <td>R</td> <td>Right, rechts</td> </tr> </table>	DE	Drive End, A-side	NDE	Non Drive End, B-side	L	Left, links	R	Right, rechts
DE	Drive End, A-side								
NDE	Non Drive End, B-side								
L	Left, links								
R	Right, rechts								



In the case of special design, details named in the operating instructions can deviate. In this case, the related supplementary documentation must be requested.



## 4.2.2 Mechanical interfaces

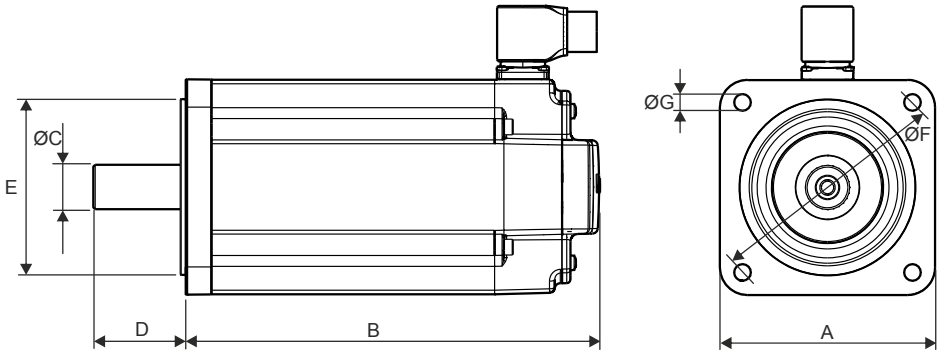

Type	A □ Flange [mm]	B Length [mm]	C Shaft $\varnothing$ [mm]	D Shaft length [mm]	E Centering collar [mm]	F Hole circle [mm]	G Mounting hole [mm]
MS2N03-B	58	See speci- fications <sup>1)</sup>	9	20	40	63	4.5
MS2N03-D			11	23			
MS2N04	82		14	30	50	95	6.6
MS2N05	98		19	40	95	115	9
MS2N06	116		24	50	95	130	9
MS2N07	140		32	58	130	165	11
MS2N10	196		38	80	180	215	14

Tab. 4-2: Mechanical interface flange, shaft

Use the following screws <sup>2)</sup> and washers for flange fastening.

Screw	M4	M6	M8	M10	M12	M14
Mounting holes $\varnothing$ [mm]	4.5	6.6	9	11	14	18
Tightening torque $M_A$ [Nm] at $\mu_K = 0.12$	3.0	10.1	24.6	48	84	206
Washer DIN EN ISO 28738	-	-	Yes	Yes	Yes	Yes

Tab. 4-3: Tightening torque of mounting screws

1) Additional documentation DOK-MOTOR\*-MS2N\*\*\*\*\*-PRIX-EN-P, Project planning manual

2) Screws according to DIN EN ISO 4762 or DIN EN ISO 4014. Fastening class 8.8. The screw lengths depends on material and installation situation. The specified tightening torque must be ensured.

### 4.2.3 Thermal motor protection

The motor temperature is monitored by two systems that are operated independently of each other. The mounted **temperature sensor** and the drive-internal **temperature model** ensure the best protection of motors against thermal overload.

The threshold values for motor temperature monitoring are contained in the encoder data memory and are read in and monitored automatically during the operation with IndraDrive controllers. Threshold values for MS2N motors:

- Motor-warning temperature (140°C)
- Motor-disconnection temperature (145°C)

Motor	Temperature sensor
MS2NXX-XXXXX-XXXXX-XXNXX-XX	PT1000 (Standard)
MS2NXX-XXXXX-XXXXX-XXAXX-XX	KTY84-130 (Discontinued type)

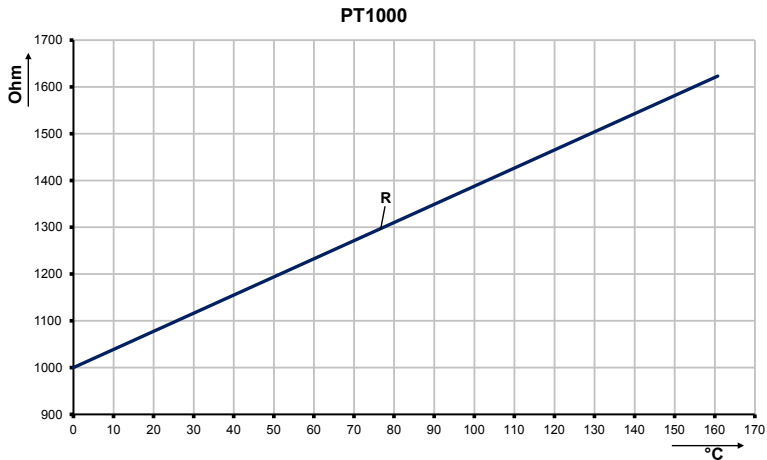
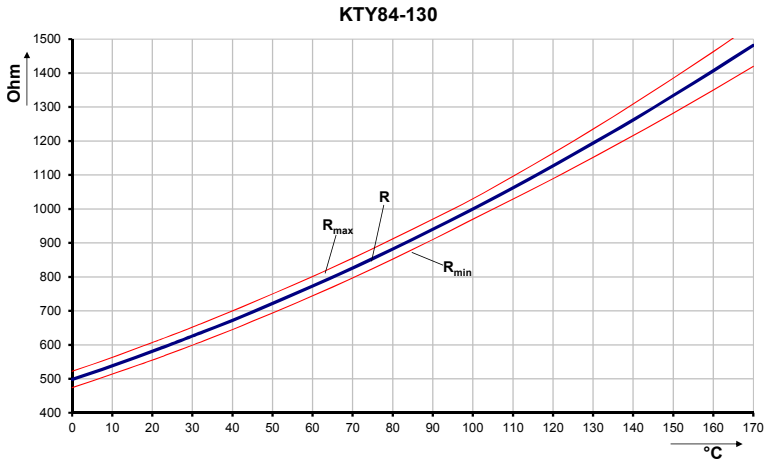

Fig. 4-1: Characteristic curve PT1000



**Fig. 4-2:** Characteristic curve KTY84-130

The output of the motor temperature is dependent from the selected motor encoder variant. In case of motors with an analog encoder (Ax, Bx), the temperature signal is output via the TP(+) and TP(-) ports in the power connection. In case of motors with digital encoder (CS/CM), the temperature signal is transmitted digitally via the encoder interface (cyclic communication).

The temperature of IndraDrive controllers is automatically evaluated via the ACUROLink interface of the encoder. You will find information about interface implementation in the manual of the encoder manufacturer, when using other controllers.

#### Hengstler:

**ACURO Encoder AD37 series - Functional Safety Item number: 2 572 032**

## 4.2.4 Motor cooling

### Self-cooling (IC410)

In case of self-cooling motors, the heat dissipation is realized via natural convection and radiation to the ambient air as well as by heat conduction to the machine construction.

The specified nominal data is reached at ambient temperatures of up to 40 °C. Unhindered vertical convection has to be ensured by a sufficient distance of 100 mm to adjacent components.

Pollution of the surface of the motor reduces heat dissipation and can result in thermal overload. The availability of the system can be increased by regular checks and cleaning of the motors. Please ensure access to the motors for maintenance purposes.

### Forced ventilation (IC416)

MS2N motors of size **07** and **10** are available as forced ventilated designs. The designation is done via the feature cooling mode „A“ (230 V / 50 Hz) and „B“ (115 V / 60 Hz) in the type code.

In case of force-ventilated motors, the energy dissipation is additionally realized via a fan that is not connected to the motor.

#### **⚠ WARNING**

**Damage to persons and machines due to drawing in of hairs, clothes or loose objects.**

Before you get closer to operating fan units, take protective measures. Do not wear jewelry, wear tight-fitting clothes and use personal protective equipment (like a hairnet). Tie your hair back. Otherwise the danger exists that hair will get ripped out.

The specified nominal data is reached at ambient temperatures of up to 40 °C. Unhindered drawing in of cooling air and heat dissipation has to be ensured by minimum distances to the machine environment.

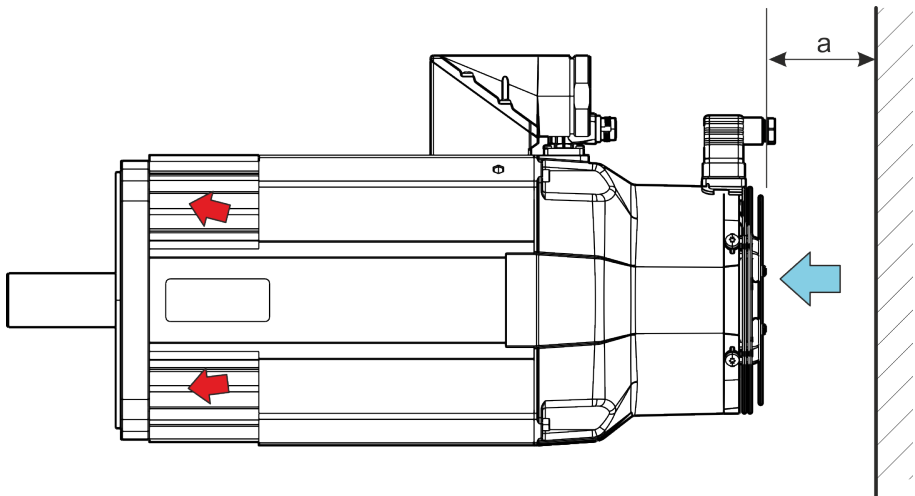

**a** Minimum distance 80 mm (MS2N07, MS2N10)

**Fig. 4-3:** Minimum distance

Blowing fans, air flow direction NDE → DE.

Operate fans only in dustfree and dry ambient air. Heated air may not be sucked in again.

Dirt and contaminants can reduce the flow rate of the fans and result in a thermal overload of the motors. The availability of the system can be increased by

regular checks and cleaning of the fans and motors. Please ensure access to the motors for maintenance purposes.

Fans are not suited to transfer ambient air

- containing abrasive particles.
- having a corroding effect, e.g., salt mist.
- containing a high dust concentration (e.g. sawdust).
- with inflammable gas/dust.

### Water cooling (IC3W7)

MS2N motors of size **07** and **10** are available as water-cooled designs. The cooling circuit of the motor is designed with stainless steel. The designation is done via the feature cooling mode „L“ within the motor type code. Nominal data is reached at ambient temperatures of up to 40 °C.

### Cooling system

The motor power loss  $P_V$  transformed to heat is dissipated using the coolant. External cooling units are necessary to operate water-cooled motors.

The cooling unit must be able to dissipate heat of the motors at any time. In the case of several motors operating on one cooling circuit, this is valid for the sum of each power loss. The necessary coolant pressure must be provided for maximum volume current.

The occurring electro-chemical processes within the cooling system must be minimized via selection of the materials. Do not combine different materials, like copper, brass, iron, zinc and halogenated plastics (e.g. tubes and sealing made of PVC).

Fix coolant ducts and check for their tightness in regular intervals.

### Potential equalization

Connect all components within the cooling system (e.g. motor, heat exchanger, pipe system, pump, pressure compensation container, etc.) with a potential equalization. Do the potential equalization with a copper bus bar or copper wire with an appropriate conductor cross-section.

Coolant ducts must not contact live parts. Please observe sufficient insulation according to the regulations valid for the place of installation.

### Coolants

The coolant must comply with certain criteria and be treated accordingly (see [tab. 4-4 "Coolant characteristics" on page 16](#)). To ensure corrosion protection and chemical stabilization, an additive must be admixed to the cooling water. The selected coolant additives (**biocides, inhibitors**) must comply with the materials in the cooling system (e.g. copper, brass, stainless steel, etc.) and minimize the micro-biological growth. Pay attention to environmentally friendly materials.

A cooling with floating water from the supply network is not allowed. Floating water can cause sediments (chalk) or corrosion within the cooling system.



In the case of other used coolants than water (e.g. oil), a performance reduction of the motor can be necessary to dissipate the created power loss.

### **NOTICE**

#### **Motor damage due to missing or incompatible coolant water!**

- For this reason, water cooled motors may only be operated as long as coolant supply is ensured.
- Do not use any cooling lubricants or cutting materials from machining processes for cooling.
- Using aggressive coolant additives or additives can lead to irreparable motor damage.



The dimensioning of the cooling system is in the responsibility of the machine manufacturer.

### **Coolant characteristics**

Adjust the required coolant, especially the material compatibility must be specified with the manufacturer of the cooling unit and the manufacturer of the coolant additives. The basic minimum requirements for the coolant are displayed in the following.

#### **Cooling water quality for motors with internal cooling circuit made of stainless steel.**

pH value (bei 20 °C)	6 ... 9
Total hardness	1.2 ... 2.5 mmol/l
Chloride concentration	< 150 ppm
Sulfate concentration	< 200 ppm
Nitrate concentration	< 50 ppm
Amount solutes	< 350 ppm
Particle size of dirt	≤ 100 µm
Conductivity	< 2000 µS/cm

**Tab. 4-4:** Coolant characteristics

### **Coolant temperature**

When setting the coolant inlet temperature within a range of 10 ... 40°C (for de-rating see [chapter 5.3 "De-rating in case of deviating ambient conditions." on page 37](#)) observe the ambient temperature and the existing relative air humidity. To avoid condensation, the coolant inlet temperature must be below the satu-

ration temperature. The following figure shows the dependency of saturation temperature of relative air humidity and air temperature.

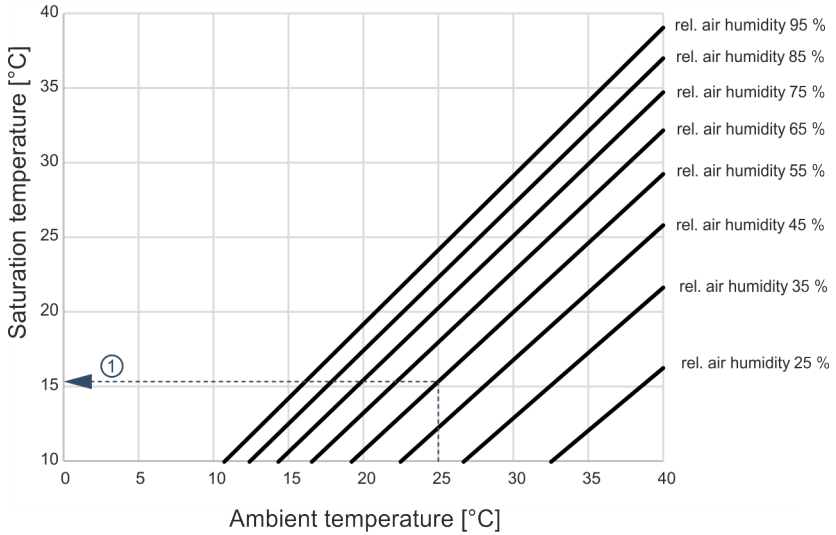

**Example ①** Saturation 15.3 °C at ambient temperature of 25°C and relative air humidity of 55%

**Fig. 4-4:** Saturation temperature depends from ambient temperature and relative air humidity



To avoid condensation of the motors, the coolant inlet temperature must be below the saturation temperature.

## 4.2.5 Encoder

### Technical data of encoder

	BASIC		STANDARD		ADVANCED				HIGH	
	AS	AM	BS	BM	CS	CM	HS	HM	DS	DM
	Single-turn	Multi-turn	Single-turn	Multi-turn	Single-turn	Multi-turn	Single-turn	Multi-turn	Single-turn	Multi-turn
Protocol	Hiperface®		Hiperface®		ACURO®link				ACURO®link	
Signal periods	16		128		-				-	
Resolution	-		-		20 bit <sup>3)</sup>				24 bit <sup>4)</sup>	
Distinguishable revolutions	1	4096	1	4096	1	4096	1	4096	1	4096
System accuracy typical/maximum	±360'' / ±520''		max ±120''		±50'' / ±70''				±20'' / ±30''	
Data transmission	analog 1 Vss		analog 1 Vss		digital				digital	
Supply voltage	7 ... 12 V		7 ... 12 V		7 ... 12 V				7 ... 12 V	
Current consumption	<50 mA		<60 mA		<130 mA				<130 mA	
Functional safety EN IEC 61508	-		SIL2		SIL2		SIL3		SIL3	
Functional safety EN ISO 13849	-		PL d		PL d		PL e		PL e	
Single cable connection	-		-		●		●		●	
Double cable connection	●		●		●		●		●	

Tab. 4-5: Technical data of encoder



**SAFETY  
ON  
BOARD**

For additional notes about integrated safety technique and prerequisites for using motors with encoder systems for using safety technique with IndraDrive refer to **Rexroth IndraDrive Integrated Safety Technology "Safe Motion" DOK-INDRV\*-SI3\*SMO-VRS-APxx-xx-P**.

3) Technical data "safety": Resolution for a safe position is **9 bit** (according to SIL 2 / SIL 3 acc. to EN IEC 61508, 62061, 61800-5-2 PL d / PL e acc. to EN ISO 13849-1)

4) Technical data "safety": Resolution for a safe position is **9 bit** (according to SIL 3 acc. to EN IEC 61508, 62061, 61800-5-2 PL d / PL e acc. to EN ISO 13849-1)



## 4.2.6 Degree of protection

The protection mode acc. to EN 60034-5 is specified by the abbreviation IP (International Protection) and two numbers for the degree of protection. The first code number stands for the degree of protection against contact and ingress of foreign bodies. The second code number stands for the degree of protection against ingress of water.

*Standard motors (specification according to type plate)*

- **IP64** without shaft sealing ring
- **IP65** with radial shaft sealing ring
- **IP67** with shaft sealing ring and sealing air connection

*Additional specifications (not on type plate)*

- Motors with fan
  - **IP65** fan motor
  - **IP2X** safety fence fan propeller
- Connection technique
  - **IP67** connectors plugged in
  - **IP65** terminal boxes in correct connection

## 4.2.7 Output shaft balancing and extension elements

### Shaft end

Shaft	Type
Smooth, without shaft sealing ring	H
Smooth, with shaft sealing ring	G
Keyway, without shaft sealing ring	L
Keyway, with shaft sealing ring	K

**Tab. 4-6:** Options according to type code

### Smooth shaft

Cylindrical shaft end according to DIN 748-3 with frontal centering hole with "DS" thread according to DIN 332-2.

The standard design for a non-positive shaft-hub connection without play and excellent smooth running. Use clamping sets, pressure sleeves or clamping elements for coupling the machine elements to be driven.

### Shaft with keyway

Cylindrical shaft end according to DIN 748-3 with frontal centering hole with "DS" thread according to DIN 332-2 and keyway.

The keyway design allows form-locking transmission of torques with constant direction and low requirements on the shaft-hub connection.

The machine elements to be driven have to be secured in axial direction via the centering hole.

Type	Key DIN 6885-A	Centering hole DIN 332 Part 2
MS2N03-B	3×3×14	DS M3
MS2N03-D	4×4×16	DS M4
MS2N04	5×5×20	DS M5
MS2N05	6×6×32	DS M6
MS2N06	8×7×40	DS M8
MS2N07	10×8×45	DS M10
MS2N10	10×8×70	DS M12

Tab. 4-7: Keyway and centering holes for MS2N motors



Keys are not included in the scope of delivery.

Design with shaft sealing ring is optional. The shaft sealing ring affects the degree of protection [chapter 4.2.6 "Degree of protection" on page 19](#). We recommend regular visual inspections on shaft sealing rings. Depending on operating conditions, signs of wear may appear after 5,000 operating hours. If necessary, replace the shaft sealing rings.



Bosch Rexroth recommends to have these repairs made by Bosch Rexroth Service.

## Balancing

MS2N motors with keyway are balanced with "half key " (half key balancing acc. to DIN ISO 21940-32).

The balancing type is specified at the shaft front end with "**H**" for half key balancing.

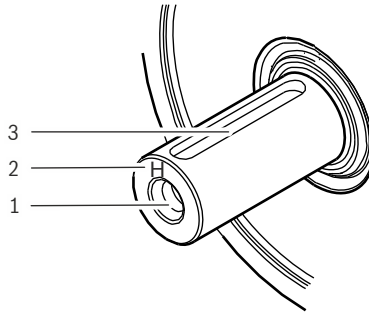

- 1 Centering hole  
2 Identification Auswuchtung

3 Keyway

Fig. 4-5: Shaft end

### Attachment of drive elements

The mode of balancing of drive elements must be adjusted to the motor. Observe the notes about mounting drive elements.

#### **⚠ CAUTION**

#### **Motor damage by intrusion of liquid!**

Pending liquids (e.g. cooling lubricants, gearbox oil, etc.) at the drive shaft are inadmissible.

When installing gearboxes please use gearboxes with closed (oil-proof) lubrication system only. Gearbox oil should not be in permanent contact with the shaft sealing ring of the motors.

### Gearbox mounting on motors

Observe the instructions in the corresponding manufacturer's documentation.

### Overdetermined bearing

When installing drive elements, avoid overdetermined bearing as impermissibly high bearing reactions can be generated due to unfavorable tolerance ratios.



If overdetermined arrangement of bearings cannot be avoided, please contact Bosch Rexroth.

### Couplings

The machine construction and the drive elements used must be carefully adapted to the motor type so as to make sure that the load limits of the shaft and the bearing are not exceeded.



When extremely stiff couplings are attached, the revolving radial force may cause an impermissibly high load on the shaft and bearing.

---

### Bevel gear pinion or helical drive pinion

Due to thermal expansion, the DE side of the drive shaft can be displaced by up to 0.6 mm in relation to the motor housing. If helical drive pinions or bevel gear pinions directly attached to the output shaft are used, this change in position will lead to

- a shift in the position of the axis, if the driving pinions are not axially fixed on the machine side,
- a thermally dependent component of the axial force, if the driving pinions are axially fixed on the machine side. This causes the risk of exceeding the maximum permissible axial force or of the gear backlash increasing to an impermissible degree.
- damage of the NDE bearing by exceeding the maximum permissible axial force.



It is recommended to use drive elements with integrated bearings and mount them on the motor shaft via axially compensating couplings.

---

## 4.2.8 Holding brakes

MS2N motors can optionally be provided with permanent magnet brakes. The backlash-free holding brakes are operated according to the "electrically-released" principle (closed-circuit principle) and open upon applying the switching voltage.

- Number of operating cycles  $\geq 5,000,000$
- The holding brakes with emergency stop function are intended to secure motor shafts at standstill. **The holding brakes are no operation brakes to decelerate motors in operation from speed.**
- In case of an emergency stop or voltage drop, the brake operation is only allowed to a limited extent. Up to 500 breaking cycles from speed 3000 1/min can be performed, whereas the maximum switched energy per emergency stop of the brake must not be exceeded. The number of brake applications per hour is 20, whereas a uniform scheduling is a precondition. For specifications about the max. switched energy per emergency stop, see [chapter "Technical data holding brakes" on page 24](#)

### CAUTION

### Malfunctions due to wear

Impermissibly high wear due to braking from speed by exceeding the specified emergency stop properties.

Impermissibly high number of braking applications during setup mode.

### Rated voltage

The rated voltage to apply the brakes is 24 V DC ( $\pm 10\%$ ).

The voltage supply of the holding brake has to be designed so as to guarantee under the worst installation and operation conditions that a sufficient voltage **24 V  $\pm 10\%$**  is available at the motor in order to release the holding brake.

The voltage drop  $\Delta U$  on the brake supply can approximately be calculated for copper conductors using the following formula:

$$\Delta U = \rho_{Cu} \cdot \left( \frac{2 \cdot l}{q} \right) \cdot I_N$$

$\Delta U$  Voltage drop [V]

$\rho_{Cu}$  Specific resistance of copper  
[ $\Omega \cdot \text{mm}^2/\text{m}$ ]

$l$  Cable length [m]

$q$  Wire cross section [ $\text{mm}^2$ ]  
 $I_N$  Rated current [A]

**Fig. 4-6:** Voltage drop of brake supply for Cu (copper) conductor

**⚠ CAUTION**

**Malfunction in case of exceeded tolerance of the rated voltage (switching voltage)**

For safe switching of the holding brake, a rated voltage of **24 V DC ±10%** is required at the motor.

Ensure correct dimensioning of the supply wires (wire length and cross-section) for the holding brake.

The control voltage can be reduced using the energy saving function after safely releasing the brake, see [chapter "Energy saving function for holding brakes" on page 25](#).

**Protective circuit**

The holding brakes are intended for direct connection to the IndraDrive controller. A protective circuit to switch inductive loads of holding brakes is integrated in IndraDrive controllers. Please observe when operating of third-party converters that MS2N motors do not have an integrated protective circuit.

**Technical data holding brakes**

MS2N Brake		03	04	05	06		07		10		
		1	1	1	1	2	1	2	1	2	3
Static holding torque	M4 [Nm]	1.8	5.0	10	10	15	20	36	33	53	90
Dynamic braking torque	M <sub>1</sub> [Nm]	1.3	4.5	4.5	4.5	11	12.5	16.5	16.5	23	33
Rated voltage	U <sub>N</sub> [V]	24									
Rated current	I <sub>N</sub> [A]	0.46	0.63	0.73	0.73	0.65	0.78	0.94	0.94	1.0	1.5
Connection time	t <sub>1</sub> [ms]	8	30	30	30	29	40	60	60	50	65
Disconnection time	t <sub>2</sub> [ms]	35	45	80	80	130	100	200	200	220	250
Maximum switched energy	W <sub>max</sub> [J]	300	400	400	400	888	340	850	850	850	1470

**Tab. 4-8:** Technical data of holding brake

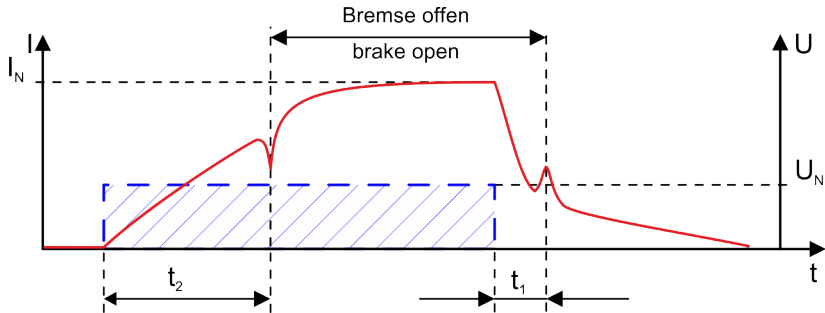

- $t_1$  Connection time (close)  
 $t_2$  Disconnection time (open)

Fig. 4-7: Switching times of static hold mode

## Energy saving function for holding brakes

### Decrease brake voltage

The control voltage of the holding brake in MS2N holding brakes can be reduced after executing the switching operation "Open brake" by using control modules (e.g. IndraDrive brake control module HAT02.1-003). By decreasing the control voltage, energy can be saved of up to 50% and the self-heating of the motor can be reduced.

To decrease the control voltage of MS2N holding brakes, the following conditions apply:

- Maximum decrease of control voltage to  $U_N \geq 17$  V DC
- Waiting time after releasing the holding brake is at least 200 ms
- Decreasing the control voltage by voltage control or pulse width modulation with a PWM cycle frequency  $\geq 4$  kHz



Refer to the instructions in the control module documentation.

Refer to the notes for dimensioning of the cable length and cable cross-section of brake cables.

## Safety instructions holding brakes

The permanent magnet brake of a MS2N motor is no safety brake. This means, a torque reduction by non-influenceable disturbance factors can occur. Especially for use in vertical axes.

**⚠ DANGER**

**Grievous bodily harm due to dangerous movements from falling or dropping axes!**

Additionally secure vertical axes to prevent them from sinking or descending after having shutdown the motor, for instance as follows:

- Lock the vertical axes mechanically,
- External brake, arrestor, clamping device.
- Weight compensation of the axes

The holding brake itself is not suitable for personal protection. Ensure protection of persons by superordinate fail-safe measures, like block danger zones via safety fences.

For European countries, additionally comply with the following standards and guidelines, e.g.

- EN 954 and ISO 13849-1 and ISO 13849-2 Safety-related parts of control systems
- Information sheet no. 005 "Gravity-loaded axes (vertical axes)" published by: DGUV Fachbereich Holz und Metall (German Employer's Liability Insurance Association Wood and Metal)

Determine the safety requirements valid for the case of application and observe the safety requirements during plant design. Observe national regulations at the installation site of the system.

### **Holding brake – Commissioning and maintenance instructions**

That is why the function and the holding brakes have to be checked in regular intervals and malfunctions must be removed in an appropriate period.

*The braking effect can be reduced by*

- Corrosion on friction surfaces, vapor and sediment
- Over voltages and too high temperatures
- Wear (increasing the air gap between armature and pole)

The holding brake functionality can be checked mechanically by hand (torque wrench) or automatically by means of the software function.

### **Manually check holding torque (M4)**

1. De-energize the motor and ensure it cannot be restarted.
2. Measure the transferable holding torque (M4) of the holding brake with a torque wrench.



## Check holding torque (M4) automatically

1. Start the "P-0-0541, C2100 Command Holding system check" The efficiency of the holding brake and the opened state are checked by starting the routine.

If the holding torque (M4) **is not achieved**, the resurfacing routine can be used to reconstitute the holding torque. Contact the Rexroth service department.

### 4.2.9 Flange exactness

The properties concentricity, run-out and alignment are defined in the flange accuracy (N, R). By default, MS2N motors are equipped with tolerance N. From frame size 06, the optional design tolerance R is available. The labeling is done in the motor type designation. (See also [chapter 4.2.7 "Output shaft balancing and extension elements" on page 19](#)).

#### Concentricity tolerance of the shaft end

Diameter shaft end [d]	Concentricity tolerance in [mm]	
	N	R
9	0.03	0.015
11, 14	0.035	0.018
19, 24	0.04	0.021
32, 38	0.05	0.025

**Tab. 4-9:** Concentricity tolerance regarding the shaft diameter for MS2N motors

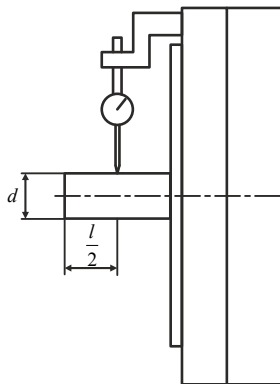

**Fig. 4-8:** Measuring system of concentricity tolerance

Measurement takes place in distance  $l/2$  (shaft end center), rectangular to the motor flange.

## Concentricity and alignment

Centering diameter [mm]	Concentricity and alignment tolerance in [mm]	
	N	R
40, 50, 95	0.08	0.04
130, 180	0.1	0.05

**Tab. 4-10:** Coaxiality and alignment tolerance related to the centering diameter in MS2N motors

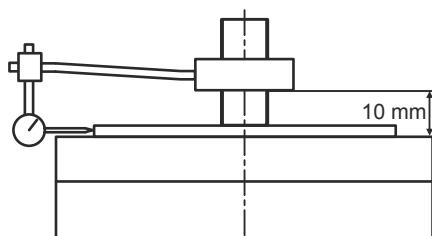

**Fig. 4-9:** Measuring system of coaxiality

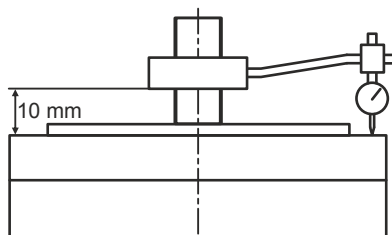

**Fig. 4-10:** Measuring system of alignment

The coaxiality and the alignment are measured in vertical motor position to exclude the influence of gravitational forces.

### 4.2.10 Vibration behavior

The oscillation behavior corresponds to oscillating quantity level A according to DIN EN 60034-14 up to the rated speed.

### 4.2.11 Bearing

The motors are equipped with a deep-groove ball bearing with high-temperature grease for prelubrication.

**Bearing size MS2N**

Type	Bearing size DE	Bearing size NDE	Floating bearing	Fixed bearing
MS2N03	6001	6000	DE	NDE
MS2N04	6003	6001	DE	NDE
MS2N05	6204	6303	DE	NDE
MS2N06	6206	6303	DE	NDE
MS2N07	6207	6205	DE	NDE
MS2N10	6308	6306	DE	NDE

**Tab. 4-11:** MS2N bearing size**Bearing service life**

The bearing lifetime is an important criterion for the availability of motors. The operating conditions influence the bearing service life  $L_{10h}$  considerably.

*The following boundary conditions apply to the bearing service life  $L_{10h}$ :*

- Operation within the specified permissible loads (radial and axial force)
- Operation within the permissible ambient conditions (temperature range 0 ... 40 °C, vibration, ... )
- Operation within the thermally permissible operating characteristic curve

The bearing lifetime also depends on the service life of the grease. A calculated grease service life was used for the mentioned specifications, taking into consideration the following boundary conditions.

- Horizontal installation
- Low vibration and impact loads
- No oscillating bearing movement < 180°
- Mean speed according to [Table 4-12](#):

Type	Mean speed
MS2N03, -04, -05, -06	≤ 3500 1/min
MS2N07	≤ 3000 1/min
MS2N10	≤ 2000 1/min

**Tab. 4-12:** Mean speed - basis of calculated grease service life

The following standard values apply under the specified preconditions for the 60K and 100 K operation modes:

 **$L_{10h}$  in case of operation after S1-60K**

$L_{10h} = 30.000$  h, in case of utilization after S1-60K and max. load factor 95% during the runtime.

### $L_{10h}$ in case of operation after S1-100K

$L_{10h} = 20.000 \text{ h}$ , in case of utilization after S1-100K and max. load factor 90% during the runtime.



When exceeding or not complying with these conditions, a reduced service life is to be expected.

### Explanation of radial and axial force

During operation, both radial and axial forces act upon the motor shaft and the motor bearing. The permissible radial force  $F_R$  in distance  $x$  from the shaft shoulder and the mean speed is specified in the radial force diagrams.

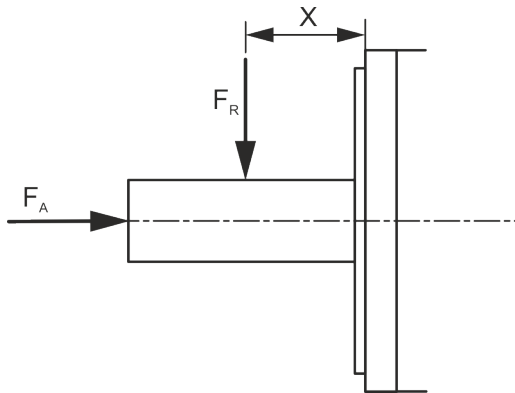

**Fig. 4-11:** Point of action of radial force  $F_R$  and axial force  $F_A$

The axial force values are the minimum permissible axial forces  $F_A$  without limitations. A detailed dimensioning is only possible if more boundary conditions are known:

- Axial and radial force with force application point
- Installation position (horizontal, vertical with the shaft end pointing to the top or bottom)
- Mean speed

Radial force diagrams are specified in the project planning manual "DOK-MOTOR\*-MS2N\*\*\*\*\*-PRxx-xx-P"

### 4.2.12 Frame size, installation type

The motors can be installed horizontally and vertically with the shaft end pointing to the top or bottom. The installation variants correspond to IM-code according to EN 60034-7 for frame size and installation type.

## Code I / Code II (EN 60034-7)

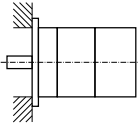
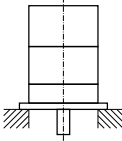
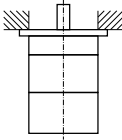
IM B5 / IM 3001		Flange attachment on the drive side of the flange
IM V1 / IM 3011		Flange attachment on the drive side of the flange, drive side facing down
IM V3 / IM 3031		Flange attachment on the drive side of the flange, drive side facing up

Avoid liquid at the drive shaft or the shaft sealing ring in case of vertical installation according to IM V3. For further information regarding the protection class, see [chapter 4.2.6 "Degree of protection" on page 19](#).

### 4.2.13 Coating

1K-standard varnish, water-based, RAL 9005 black

An additional varnish with a coat thickness of max. 40 µm is allowed.

Protect all safety notes (stickers), type plates and open connectors with a painting protection when painting additionally.

#### 4.2.14 Air-pressure connector kit

A defined over pressure can be conducted into the motor with an air-pressure connector kit. Therewith, penetration of damaging liquids can be prevented. The areas of application for sealing air are all installation locations in which humid air or coolant can come into direct contact with the motors, especially in wet processing rooms.

### NOTICE

**Damage due to permanent existing liquid on the shaft sealing ring!**

The use of sealing air does **not** prevent the penetration of continuously existing liquid on the shaft sealing ring (e.g. for open gearboxes). Due to capillary action, gearbox oil can penetrate into the motor and damage it, despite using sealing air.

The pressure air must be free from oil and dry, according to DIN ISO 8573-1 Class 3 (usually in pressure air nets).

Designation	Value
Operating pressure	0.1 ± 0.05 bar
Max. relative humidity	20...30 %
Air	dry, free from dust and oil (DIN ISO 8573-1 Class 3)
Necessary compressed air hose	4 × 0.75 (not included in the scope of delivery)

**Tab. 4-13:** Specification compressed air for sealing air application

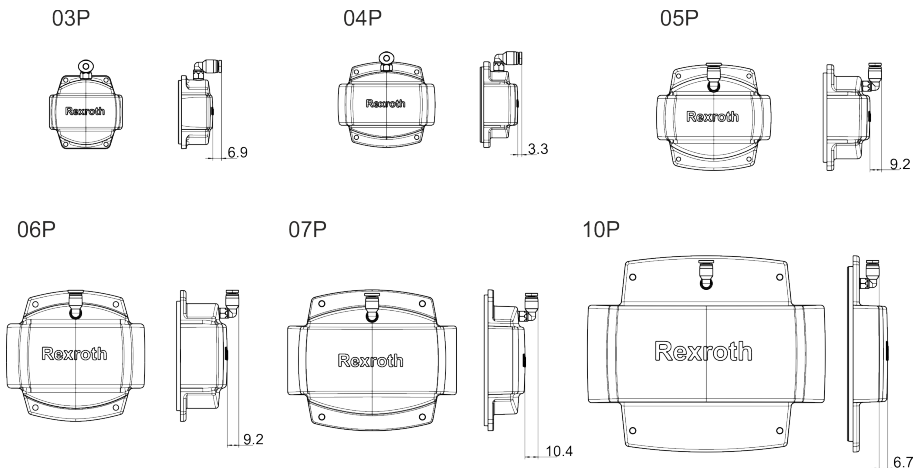

**Fig. 4-12:** Sealing air connection variants

Motor	Connection, rotatable	Total length [mm]	S [mm]
MS2N03	03P	L + 15 + S	6.9
MS2N04	04P	L + 15 + S	3.3
MS2N05	05P	L + 18 + S	9.2
MS2N06	06P	L + 18 + S	9.2
MS2N07	07P	L + 16 + S	10.4
MS2N10	10P	L + 16	-

L Measure of length "Standard L" from specifications

**Tab. 4-14:** Total length of motor with sealing air connection  
Further information [chapter 6.4 "Sealing air connection "](#) on page 76.

### 4.2.15 Noise emission

The typical sound pressure level  $L_p(A)$  is specified for the speed range 0 rpm up to the rated speed, see [chapter 4.2.1 "Basic data" on page 9](#). The installation situation affects the noise emission.

## 4.3 Product identification

### 4.3.1 Type code

The type code is printed onto the type plate of the motor. For the meaning of the type code refer to the following details.

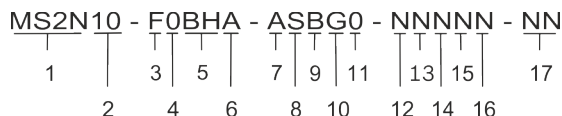

**Fig. 4-13:** Type code MS2N construction

1	Product	10	Shaft
2	Frame size	11	Holding brake
3	Frame lengths	12	Flange exactness
4	Characteristics of moment of inertia of the rotor	13	Bearing
5	Winding code	14	Frame size
6	Cooling	15	Coating
7	Encoder performance	16	Other design
8	Encoder design	17	Special design
9	Electrical connection		

**Tab. 4-15:** Type code MS2N meaning

### 4.3.2 Type plate

The type plate contains all relevant product data.

<b>Rexroth</b>	3~ PM-MOTOR TYP: MS2N10-E0BNA-BMBG3-NNNNN-NN	(7260)
MNR: R911384584	Made in Germany	
SN: 7260703123456	FD: 16W14      A008	
	P(N) 19,5 kW      I(N) 37,4 A      n(N) 2660 min-1 M(0) 119 Nm      I(0) 62,9 A      n(max) 6000 min-1	IP65
	U(max) AC 600 V	m 53 kg T.CL. 155
	Brake 90,0 Nm      DC 24 V      1,5 A	I.SY. ECM1
	Fan f(N) 50/60 Hz      U(N) AC 400/480 V      I(N) 0,12/0,12 A	
Bosch Rexroth AG, DE-97816 Lohr		Hotline: +49 9352 405060



**Fig. 4-14:** Type plate MS2N (example)

TYPE	Product type code	n(max)	Maximum speed
SN	Serial number	U(max)	Maximum voltage UL
FD	Manufacturing date	IP65	Degree of protection IPxx



P(N)	Rated power - 100K	m	Mass
I(N)	Rated current - 100K	T.CL.	Thermal class
n(N)	Rated speed (100K)	I.SY.	Insulation system identification
M(0)	Standstill torque - 100 K	SI	Use in systems for "integrated safety technique" prepared.
I(0)	Standstill current - 100 K		
Brake	Holding brake data (optional)	Fan	Data motor fan (optional)

**Tab. 4-16:** Type plate specification MS2N  
The following marks of conformity are used.

Mark of conformity	Meaning
	Conformity with applicable EC Directives For MS2N motors, conformity according to low-voltage directive 2014/35/EU , EN 60034-1, EN 60034-5.
	The UL Recognized Component Mark identifies recognized component parts which are components of a bigger product or system
	Motors of MS2N series fulfill the specified technical requirements of the EAC member states in the tariff union. The member states are Russia, Belarus and Kazakhstan.

**Tab. 4-17:** Meaning of marks of conformity

## 5 Operating conditions and handling

### 5.1 Ambient conditions in operation, at transport and storage

Ambient climatic conditions are defined in classes according to DIN EN 60721. They are based on long-term experiences and take all influencing variables into account, e.g., air temperature and air humidity.

The permanent use of motors according to class 3K4 by complying with the deviations according the following table is possible. Comply with the specified conditions for transport and storage.

	Operation	Transport	Storage
Ambient temperature	0 ... +40 °C	-25 ... +70 °C	-25 ... +55 °C
Relative humidity	5 ... 95 %	5 ... 95 %	5 ... 75 %
Absolute humidity	1 ... 29 g/m <sup>3</sup>	1 ... 60 g/m <sup>3</sup>	1 ... 29 g/m <sup>3</sup>
Condensation	Not allowed	Not allowed	Not allowed
Climatic class	corresponding to 3K4 according to EN 60721-3-3	corresponding to 2K3 according to EN 60721-3-2	corresponding to 1K3 according to EN 60721-3-1
Mechanical strength	see <a href="#">Chapter 5.4 "Vibration load during operation"</a>	see <a href="#">Chapter 5.5 "Shock load during transport und storage"</a>	

Tab. 5-1: Ambient conditions

### 5.2 Ambient temperature und installation altitude in operation

According to DIN EN 60034-1, the motor performance data specified below are valid for:

- Ambient temperature 0 ... +40 °C
- Installation altitude 0 ... 1,000 m above sea level

When exceeding the given limits, reduce the performance data of the motors.

### 5.3 De-rating in case of deviating ambient conditions.

#### Reduce high performance data:

1. Reduce the standstill torque  $M_{0\ 60K}$  or  $M_{0\ 100K}$  specified in the data sheet, with the following factors.

We have:

$$M_{0\ red} = M_{0\ 60K} \times f_{TH\ 60K}$$

$$M_{0\ red} = M_{0\ 100K} \times f_{TH\ 100K}$$

$$M_{0\ red} = M_{0\ 100K} \times f_{TH\ W}$$

2. Pan the S1-characteristic curve  $M_{S1}$  parallel to the speed axis to the junction of the S1-characteristic curve and to the calculated point  $M_{0\ red}$  on the torque axis.

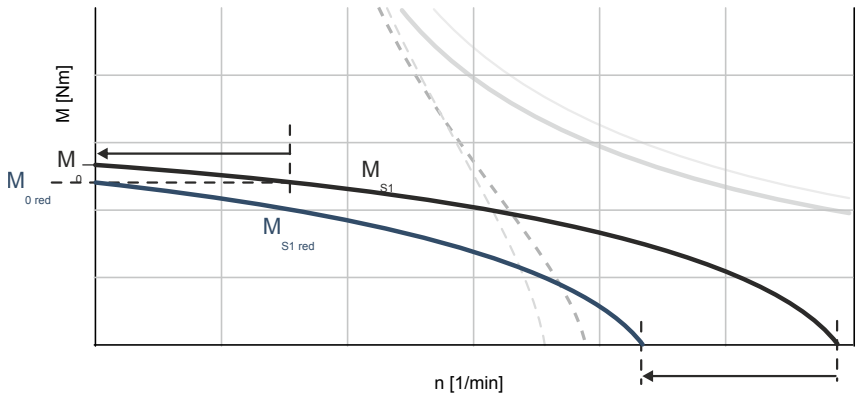

**Fig. 5-1:** Determine S1-characteristic curve  $M_{S1\ red}$  with de-rating factor  $f_{TH}$

The determined characteristic curve  $M_{S1\ red}$  shows approximately the S1-characteristic curve with appropriate de-rating.

#### De-rating factors for self-cooling 60K

Height [m]	40 °C	45 °C	50 °C	55 °C	60 °C
1000	1.00	0.94	0.88	0.83	0.78
1500	0.97	0.91	0.85	0.81	0.76
2000	0.94	0.88	0.83	0.78	0.73
2500	0.90	0.85	0.79	0.75	0.70
3000	0.86	0.81	0.76	0.71	0.67

**Tab. 5-2:**  $M_{0\ 60K}$  - De-rating Factor  $f_{TH\ 60K}$  for MS2N03 ... 10 (standard values)

**De-rating factors for self-cooling 100K and forced ventilation**

Height [m]	40 °C	45 °C	50 °C	55 °C	60 °C
1000	1.00	0.96	0.92	0.88	0.85
1500	0.97	0.93	0.89	0.85	0.82
2000	0.94	0.90	0.86	0.83	0.80
2500	0.90	0.86	0.83	0.79	0.77
3000	0.86	0.83	0.79	0.76	0.73

**Tab. 5-3:**  $M_{0\ 100K}$  - De-rating factor  $f_{TH\ 100K}$  for MS2N03 ... 10 (standard values)**De-rating factors for water cooling**

Height [m]	40 °C	45 °C	50 °C	55 °C	60 °C
1000	1.00	0.96	0.92	0.88	0.85
1500	0.99	0.95	0.91	0.87	0.84
2000	0.97	0.93	0.89	0.85	0.82
2500	0.96	0.92	0.88	0.84	0.81
3000	0.95	0.91	0.87	0.83	0.80

**Tab. 5-4:**  $M_{0\ 100K}$  - De-rating Factor  $f_{TH\ W}$  for MS2N07 ... 10 (standard values)

To avoid condensation of the motors, the coolant supply temperature must be below the saturation temperature. [fig. 4-4 "Saturation temperature depends from ambient temperature and relative air humidity"](#) on page 17.

## 5.4 Vibration load during operation

Vibrations are sine-wave oscillations in stationary use, which vary in their effect on the resistance of the motors depending on their intensity.

The specified limit values are valid for frequencies of 10-2,000 Hz during stimulation on the motor flange. Limitations can be necessary for occurring resonances depending on the application and installation situation.

The following limit values apply according to EN 60068-2-6 for MS2N motors:

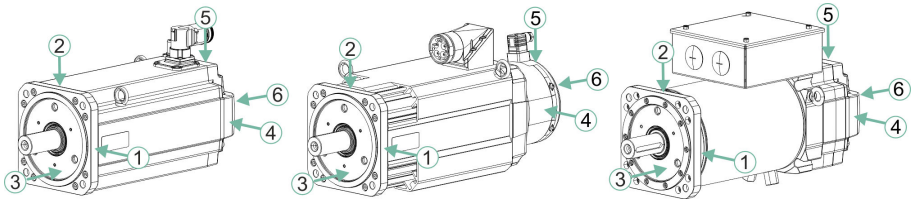

Fig. 5-2: Vibration load on measuring points

Direction	Measuring point	Limit value (10-2000 Hz)		
		Motors Self-cooling	Motors Forced ventila- tion	Motors Water cooling
Radial	1, 2 (radial motor flange)	30 m/s <sup>2</sup>	10 m/s <sup>2</sup>	10 m/s <sup>2</sup>
	4, 5 (radial bearing shield / fan)	50 m/s <sup>2</sup>	25 m/s <sup>2</sup>	25 m/s <sup>2</sup>
Axial	3 (axial motor flange)	10 m/s <sup>2</sup>	10 m/s <sup>2</sup>	10 m/s <sup>2</sup>
	6 (axial bearing shield / fan)	25 m/s <sup>2</sup>	25 m/s <sup>2</sup>	25 m/s <sup>2</sup>

Tab. 5-5: Permissible vibration load for MS2N motors

Check the vibration load on the fan housing in case of forced ventilation. The specified values must not be exceeded.

## 5.5 Shock load during transport und storage

MS2N motors comply with the transport condition requirements of class 2M1 (shock during transport) acc. to EN 60721-3-2 compare with [chapter 5.6 "Transport \(shipping\)" on page 40](#). Function-impairing effects are avoided as long as the specified limits are complied with.

Frame size	Maximum allowed shock load (11 ms)	
	Axial	Radial
MS2N03, -04, -05	100 m/s <sup>2</sup>	1000 m/s <sup>2</sup>
MS2N06		500 m/s <sup>2</sup>
MS2N07		300 m/s <sup>2</sup>
MS2N10		200 m/s <sup>2</sup>

**Tab. 5-6:** Permissible shock load for MS2N motors

The specified limit values do not apply to half-sine-shaped single shock load acc. to EN 60068-2-27.



The specifications do not apply to **motor operation**. Applications with continuous shock load make a case-by-case review necessary.

## 5.6 Transport (shipping)

The motors have to be transported in their original packaging, complying with 2K2, 2B1, 2C2, 2S2, 2M1 acc. to DIN EN 60721-3-2.

Please observe the following classification limitations:

- [chapter 5.1 "Ambient conditions in operation, at transport and storage" on page 36](#)
- No occurrence of salt mist



Before transport, discharge the liquid coolant from liquid-cooled motors to avoid frost damage.

### Transport by air

If motor components with permanent magnets are shipped by air, the DGR (Dangerous Goods Regulations) of the IATA (International Air Transport Association) for hazardous materials of class 9 which also include magnetized substances and objects must be observed. For example, these regulations are applicable for

- Secondary parts of synchronous linear motors
- Rotors of synchronous kit motors
- Rotors of synchronous housing motors (if shipped as motor components, i.e., separated from the stator or motor housing in case service work is required)

For information on the maximum allowed magnetic strengths and methods of measuring such magnetic field strengths, please refer to the current IATA DGR (chapter 3.9.2.2).

## 5.7 Transport with lifting devices

### WARNING

**Risk of injury and material damage due to improper handling during transport!**



- Only use lifting devices suited for the weight of the motors. Use lifting sling belts or lifting eye bolts. Secure the lifting eye bolts before use.
- Never walk under hanging loads.
- Do not lift the motor at the shaft or on the optional fan housing.
- Use suitable protective equipment and protective clothing during transport, and wear safety shoes.

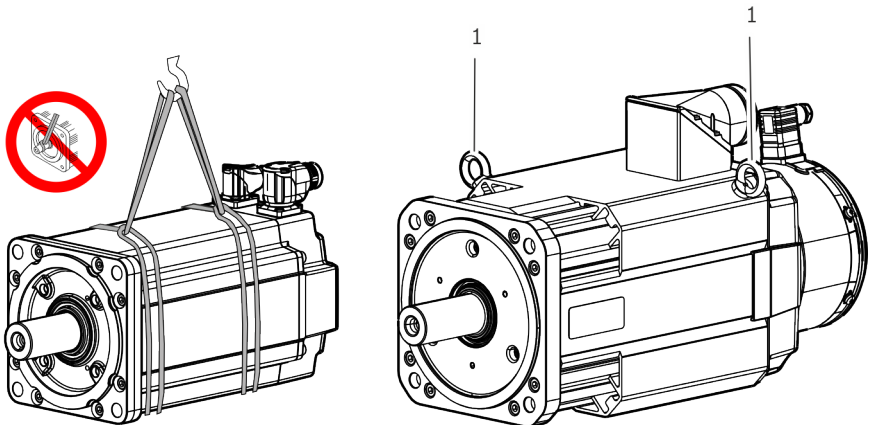

1 Eye bolts (check firm seating before use)

**Fig. 5-3:** Lifting and transporting motors

- Before transporting the motor, determine the weight of the motor. For more details about motor weight, please refer to the type plate or the Project Planning Manual (Technical Data).
- Adjust the carrying capacity of the lifting device to the motor weight.
- If provided by the manufacturer, all lifting eye bolts must be used and tightened before use.
- Avoid increased transport vibrations.
- Remove any existing transport locks prior to commissioning and keep them.

**NOTICE**

Never touch the connection points of electrostatic sensitive devices!



Installed components (e.g., KTY84, encoder) may contain electrostatic sensitive devices (ESD).

- Observe the ESD safety measures.

## 5.8 Storage

Store the motors in their original packaging in a dry, dust-free, vibration-free and light-protected place without direct solar radiation. Comply with the classes 1K2, 1B1, 1C1, 1S1, 1M2 specified for storage acc. to DIN EN 60721-3-2.

Please observe the following classification limitations:

- [chapter 5.1 "Ambient conditions in operation, at transport and storage" on page 36](#)
- No occurrence of salt mist

**NOTICE**

Damage due to moisture and humidity!

- Protect the products from dampness and corrosion.
- Store them only in rainproof and dry rooms.



Before storage, discharge the liquid coolant from liquid-cooled motors to avoid frost damage.

Additional measures have to taken upon commissioning to ensure smooth functioning - irrespective of the storage time which may be longer than the warranty period of our products. Warranty extension is not a consequence.

### Motors

Storage time/months			Measures for commissioning
> 1	> 12	> 60	
●	●	●	Visual inspection of all parts to be damage-free
●	●	●	Resurface the holding brake
	●	●	Check the electric contacts to verify that they are free from corrosion
	●	●	Let the motor run in without load for one hour at 800 ... 1000 rpm
	●	●	Measure insulation resistance. Dry the winding at a value of < 1kOhm per volt rated voltage.
		●	Exchange bearings
		●	Exchange encoders

**Tab. 5-7:** Measures before commissioning motors that have been stored over a prolonged period of time



## Cables and connectors

Storage time/months			Measures for commissioning
> 1	> 12	> 60	
●	●	●	Visual inspection of all parts to be damage-free
	●	●	Check the electric contacts to verify that they are free from corrosion
		●	Visually inspect the cable jacket. Do not use the cable if you detect any abnormalities (squeezed or kinked spots, color deviations, ...).

**Tab. 5-8:** Measures before commissioning cables and connectors that have been stored over a prolonged period of time

## 5.9 Operation on foreign converters

Principally, operating MS2N motors on foreign converters is possible. The following requirements and limitations on foreign converters must be observed.

### WARNING

**Danger of explosion or material damage due to overload!**

Observe the following requirements for safe motor operation on foreign converters. Connection of all necessary sensors and additional devices for a safe operation and their evaluation lies in the sole responsibility of the plant manufacturer or operator.

#### Requirements on the power output stage

- Converter with pulse width modulation
- Pulse frequency 4 kHz ...16 kHz

#### Voltage load of the motor

During converter operation, the motor underlies a higher voltage load (insulation system, bearing) than on a sinusoidal source voltage only.

*Standard values for peak voltage and rate of rise of voltage:*

- Peak voltage  $U_{pk}$  on motor clamps  $\leq 1.56$  kV
- Rate of rise of voltage  $du/dt \leq 5$  kV/ $\mu$ s

*Maximum allowed limit load:*

In the case of critical rate of rise of off-state voltage  $du/dt \geq 5$  kV/ $\mu$ s, the limit values (peak voltage, voltage rise time) according to limit curves A according to **DIN VDE 0530-25 (VDE 0530-25):2009-08 (Figure 14 Limit curve A)** must be kept. Therefore, observe the limit values for voltage rise time and critical rate of rise of off-state voltage.

*Limit values for voltage rise time and critical rate of rise of off-state voltage:*

- Voltage rise time  $> 0.17$   $\mu$ s
- Critical rate of rise of off-state voltage  $du/dt < 8$  kV/ $\mu$ s

#### Monitoring functions

- Speed monitoring of maximum permissible speed
- The motor load must not exceed the permitted continuous operation characteristic curve. The converter setting data for controlling and monitoring must comply with the type code data.
- Temperature control to protect from thermal overload
  - The temperature sensor of the motor winding must be connected and evaluated on the converter (ensure monitoring function, observe polarity of temperature sensor, limit switch-off temperature according to [chapter 4.2.3 "Thermal motor protection" on page 12](#)).

- Temperature model or  $I^2t$ -monitoring within converter. Due to the coupling time of the temperature sensor, an additional suitable temperature model or an  $I^2t$ -monitoring must be used.

**Requirements for motor operation with holding brake**

- Ensure the brake functionality during normal operation due to voltage control, current monitoring, cyclic control of the brake holding torque, for example.
- Provide an external or an integrated protective circuit within the foreign converter to switch the holding brake (inductive load).
- Never use the holding brake of the motor as an operating brake.
- Idle time after an emergency stop before restarting  $\geq 3$  minutes.

## 6 Assembly

### 6.1 Motor assembly

#### 6.1.1 Flange assembly

#### **NOTICE**

#### **Motor damage due to ingress of liquids!**

Liquid which exists over a longer period on the shaft sealing ring of the output shaft can ingress into the motor and cause damage.

- Ensure that liquid cannot be present at the output shaft.
- Do not mount any open gearboxes (gearboxes that are not hermetically sealed).

Use all motor mounting holes to mount the motor safely to the machine. For details on mounting holes, please refer to the dimension sheets.

- If coupling is direct, ensure that the support is plane and the orientation is precise.
- Avoid pinching or jamming the centering collar on the motor side.
- Avoid damaging the receptacle fit on the plant side.
- Use screws and washers for flange assembly according to [tab. 4-3 "Tightening torque of mounting screws "](#) on [page 11](#).

#### 6.1.2 Attaching transmission elements

Fit and pull off the transmission elements such as pulleys and couplings only with suitable equipment; heat them, if necessary.

- Avoid inadmissible belt tensions. Please consider the allowed radial and axial forces in the project planning manuals.
- The balancing state of transmission elements must comply with the full-key balancing of the motors.

#### **NOTICE**

#### **Motor damage due to strikes onto the motor shaft**



Do not strike the shaft end and do not exceed the allowed axial and radial forces of the motor.

## Fitting

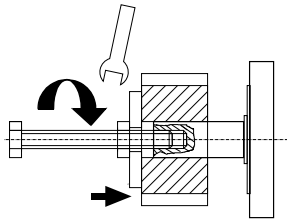

**Fig. 6-1:** Fitting the transmission element

Use the centering hole for fitting transmission elements. For details on centering holes, please refer to the project planning manual. If necessary, heating up the transmission element.

## 6.2 Connecting the electric supply

### 6.2.1 Safety

#### **WARNING**

**Danger! Electric voltage! Operations in the vicinity of live parts are extremely dangerous.**



Any work required on the electric system may be carried out only by skilled electricians. Tools for electricians (VDE tools) are absolutely necessary.

*Prior to commencing work:*

1. Isolate (even auxiliary circuits).
2. Secure against reactivation.
3. Ensure de-energization.
4. Ground and short-circuit.
5. Cover or shield any adjacent live parts.

#### **WARNING**

**High electric voltage! Danger to life, risk of injury due to electric shock.**



While the rotor is rotating, motors with permanent magnet excitation create a voltage > 60 V at the motor connections.

- Any work may only be carried out while the motor is at standstill.
- Never connect or disconnect plug connectors under load!

#### **NOTICE**

**Never touch the connection points of electrostatic sensitive devices!**



Installed components contain electrostatic sensitive devices (EGB).

- Do not touch connection points.
- Observe ESD safety measures.



## 6.2.2 MS2N Electrical connection "S"

### M23 view (single cable connection) / rotation range

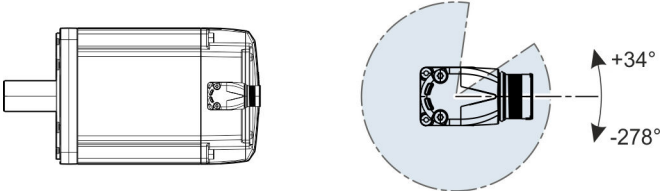
	
Flange socket	Single cable connection
Connector size	M23
Output direction	rotatable (max. 10x)
Adjustment torque	4 ... 10 Nm
Locking	SpeedCon

Tab. 6-1: MS2N...S... Flange socket

### Pol pattern M23 (single cable connection)

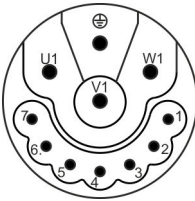
Designation		Function					
		Encoder					
		Cx	Dx	Hx	Cx	Dx	Hx
		with brake			without brake		
	U1	A1			A1		
	V1	A2			A2		
	W1	A3			A3		
	⊕	PE			PE		
	1	+UB			+UB		
	2	GND			GND		
	3	Data+			Data+		
	4	Data-			Data-		
5	Shld			Shld			
6	BD(+)			n.c.			
7	BD(-)			n.c.			

Tab. 6-2: Pin assignment pole pattern M23 (single cable connection)

Note for assembly about SpeedCon connectors, see [chapter 6.2.9 "SpeedCon connectors" on page 66](#)





### 6.2.3 MS2N Electrical connection "D"

View M17 (double cable connection) / rotating area

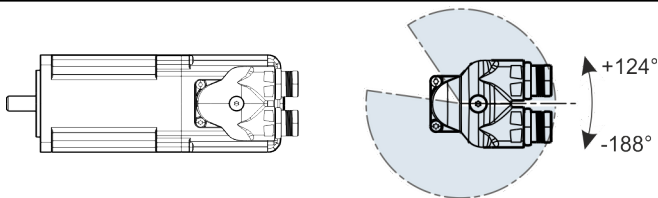
		
Flange socket	Power	Encoder
Connector size	M17	M17
Output direction	rotatable (max. 10x)	
Adjustment torque	2 ... 10 Nm	
Locking	SpeedCon	

Tab. 6-3: MS2N...-.....D..-..... Flange socket

Pol pattern M17, power (double cable connection)

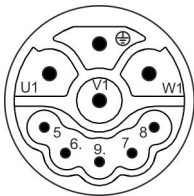
Designation	Function									
	Encoder									
	Ax	Bx	Cx	Dx	Hx	Ax	Bx	Cx	Dx	Hx
	with brake					without brake				
	U1	A1		A1		A1		A1		
	V1	A2		A2		A2		A2		
	W1	A3		A3		A3		A3		
	⊕	PE		PE		PE		PE		
	5	TP(+)		n.c.		TP(+)		n.c.		
	6	TP(-)		n.c.		TP(-)		n.c.		
	7	BD(+)		BD(+)		n.c.		n.c.		
	8	BD(-)		BD(-)		n.c.		n.c.		
	9	n.c.		n.c.		n.c.		n.c.		

Tab. 6-4: Pin assignment pol pattern M17, power

Note for assembly about SpeedCon connectors, see [chapter 6.2.9 "SpeedCon connectors"](#) on page 66

## Pol pattern M17, encoder (double cable connection)

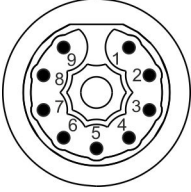
Designation		Function				
		Encoder				
		Ax	Bx	Cx	Dx	Hx
	1	+UB		+UB		
	2	n.c.		n.c.		
	3	Data+		Data+		
	4	Data-		Data-		
	5	A+		n.c.		
	6	A-		n.c.		
	7	B+		n.c.		
	8	B-		n.c.		
	9	GND		GND		

**Tab. 6-5:** Pin assignment pole pattern M17, encoder

Note for assembly about SpeedCon connectors, see [chapter 6.2.9 "SpeedCon connectors"](#) on page 66

### 6.2.4 MS2N Electrical connection "U"

View M23 power, M17 encoder (Dobule cable connection) / rotating area

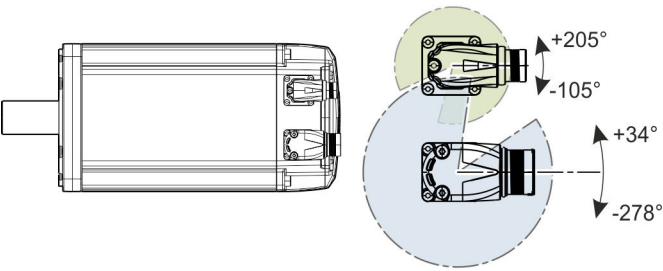

Flange socket	Power	Encoder
Connector size	M23	M17
Output direction	rotatable (max. 10x)	
Adjustment torque	4 ... 10 Nm	2 ... 6 Nm
Mode of locking	SpeedCon	SpeedCon

Tab. 6-6: MS2N...U... Flange socket

### Pol pattern M23, power (double cable connection)

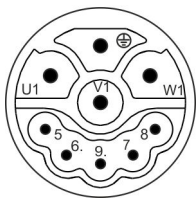
Designation	Function									
	Encoder									
	Ax	Bx	Cx	Dx	Hx	Ax	Bx	Cx	Dx	Hx
	with brake					without brake				
	U1	A1		A1		A1		A1		
	V1	A2		A2		A2		A2		
	W1	A3		A3		A3		A3		
	⊕	PE		PE		PE		PE		
	5	TP(+)		n.c.		TP(+)		n.c.		
	6	TP(-)		n.c.		TP(-)		n.c.		
	7	BD(+)		BD(+)		n.c.		n.c.		
	8	BD(-)		BD(-)		n.c.		n.c.		
	9	n.c.		n.c.		n.c.		n.c.		

Tab. 6-7: Pin assignment pol pattern M23, power

Note for assembly about SpeedCon connectors, see [chapter 6.2.9 "SpeedCon connectors"](#) on page 66

## Pol pattern M17, encoder (double cable connection)

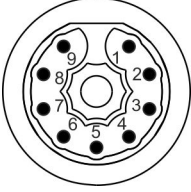
Designation		Function				
		Encoder				
		Ax	Bx	Cx	Dx	Hx
	1	+UB		+UB		
	2	n.c.		n.c.		
	3	Data+		Data+		
	4	Data-		Data-		
	5	A+		n.c.		
	6	A-		n.c.		
	7	B+		n.c.		
	8	B-		n.c.		
	9	GND		GND		

**Tab. 6-8:** Pin assignment pole pattern M17, encoder

Note for assembly about SpeedCon connectors, see [chapter 6.2.9 "SpeedCon connectors"](#) on page 66

### 6.2.5 MS2N Electrical connection "V"

View M40 power, M17 encoder (double cable connection) / rotating area

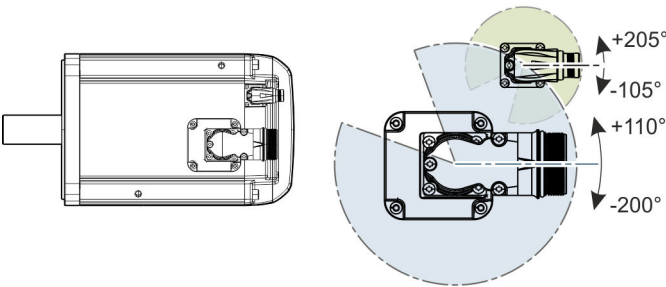

Flange socket	Power	Encoder
Connector size	M40	M17
Output direction	rotatable (max. 10x)	
Adjustment torque	12 ... 18 Nm	2 ... 6 Nm
Locking (standard)	SpeedCon	SpeedCon

Tab. 6-9: MS2N.....V..... Flange socket

### Pol pattern M40 power, (double cable connection)

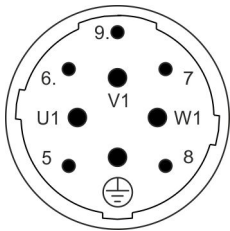
Designation	Function									
	Encoder									
	Ax	Bx	Cx	Dx	Hx	Ax	Bx	Cx	Dx	Hx
	with brake					without brake				
	U1	A1		A1		A1		A1		
	V1	A2		A2		A2		A2		
	W1	A3		A3		A3		A3		
	⊕	PE		PE		PE		PE		
	5	TP(+)		n.c.		TP(+)		n.c.		
	6	TP(-)		n.c.		TP(-)		n.c.		
	7	BD(+)		BD(+)		n.c.		n.c.		
	8	BD(-)		BD(-)		n.c.		n.c.		
	9	n.c.		n.c.		n.c.		n.c.		

Tab. 6-10: Pin assignment pole pattern M40, power

Note for assembly about SpeedCon connectors, see [chapter 6.2.9 "SpeedCon connectors" on page 66](#)

## Pol pattern M17, encoder (double cable connection)

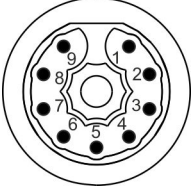
Designation		Function				
		Encoder				
		Ax	Bx	Cx	Dx	Hx
	1	+UB		+UB		
	2	n.c.		n.c.		
	3	Data+		Data+		
	4	Data-		Data-		
	5	A+		n.c.		
	6	A-		n.c.		
	7	B+		n.c.		
	8	B-		n.c.		
	9	GND		GND		

**Tab. 6-11:** Pin assignment pole pattern M17, encoder

Note for assembly about SpeedCon connectors, see [chapter 6.2.9 "SpeedCon connectors"](#) on page 66

### 6.2.6 MS2N Electrical connection "A" or "B"

View M58 power, M17 encoder (double cable connection) / rotating area

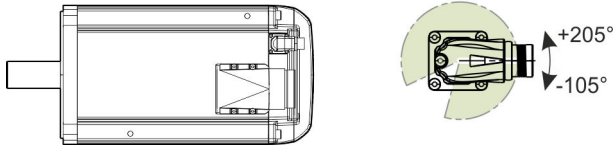
		
Flange socket	Power	Encoder
Connector size	M58	M17
Output direction	A-side / B-side	rotatable (max. 10x)
Adjustment torque	-	2 ... 6 Nm
Locking	Thread	SpeedCon

Tab. 6-12: MS2N...-.....-..□-.....-. Flange socket (□ = A or B)

### Pol pattern M58, power (double cable connection)

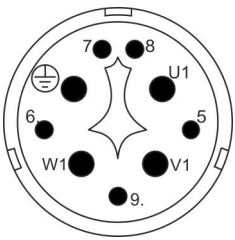
Designation	Function									
	Encoder									
	Ax	Bx	Cx	Dx	Hx	Ax	Bx	Cx	Dx	Hx
	with brake					without brake				
	U1	A1		A1		A1		A1		
	V1	A2		A2		A2		A2		
	W1	A3		A3		A3		A3		
	⊕	PE		PE		PE		PE		
	5	TP(+)		n.c.		TP(+)		n.c.		
	6	TP(-)		n.c.		TP(-)		n.c.		
	7	BD(+)		BD(+)		n.c.		n.c.		
	8	BD(-)		BD(-)		n.c.		n.c.		
	9	n.c.		n.c.		n.c.		n.c.		

Tab. 6-13: Pin assignment pol pattern M17, power  
 Note for assembly for M58 connector with thread, see chapter 6.2.10 "Plug-in connector with threaded connection" on page 67

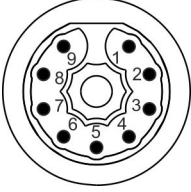

## Pol pattern M17, encoder (double cable connection)

Designation		Function				
		Encoder				
		Ax	Bx	Cx	Dx	Hx
	1	+UB		+UB		
	2	n.c.		n.c.		
	3	Data+		Data+		
	4	Data-		Data-		
	5	A+		n.c.		
	6	A-		n.c.		
	7	B+		n.c.		
	8	B-		n.c.		
	9	GND		GND		

**Tab. 6-14:** Pin assignment pole pattern M17, encoder

Note for assembly about SpeedCon connectors, see [chapter 6.2.9 "SpeedCon connectors"](#) on page 66

### 6.2.7 MS2N Electrical connection "T"

View terminal box "T" power, M17 encoder (double cable connection) / rotating area

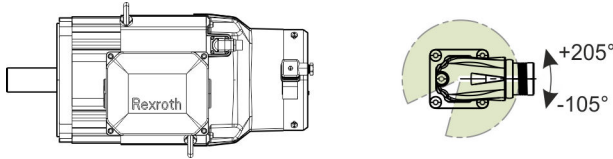
		
Connection	Power Terminal box	Encoder Flange socket
Connector size	-	M17
Output direction	A-side / B-side	rotatable (max. 10x)
Adjustment torque	-	2 ... 6 Nm
Locking	-	SpeedCon

Tab. 6-15: MS2N...T... Terminal box / flange socket

### Pol pattern M17, encoder (double cable connection)

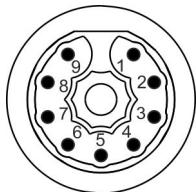
Designation	Function				
	Encoder				
	Ax	Bx	Cx	Dx	Hx
	1	+UB		+UB	
	2	n.c.		n.c.	
	3	Data+		Data+	
	4	Data-		Data-	
	5	A+		n.c.	
	6	A-		n.c.	
	7	B+		n.c.	
	8	B-		n.c.	
	9	GND		GND	

Tab. 6-16: Pin assignment pole pattern M17, encoder

Note for assembly about SpeedCon connectors, see [chapter 6.2.9 "SpeedCon connectors" on page 66](#)

## Terminal boxes "T", power (double cable connection)

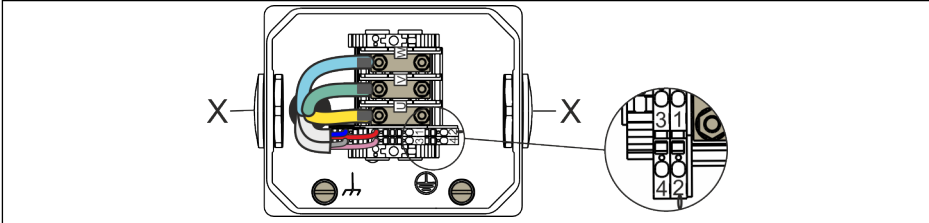

MS2N <sup>1) 2)</sup>	Clamp / data	IndraDrive	Cabel RL2 <sup>3)</sup>
U	Bolts M5, M <sub>A</sub> 2 ... 3 Nm	A1	1
V	Rated cross section 16 mm <sup>2</sup>	A2	2
W	Rated current 65 A	A3	3
1	Tension spring connection 0.5 ... 2.5 mm <sup>2</sup> with wire end ferrules	BD(+)	7
2		BD(-)	8
3		TP1(+)	5
4		TP2(-)	6
⊕	Screwed connection M8, M <sub>A</sub> 3.8 Nm	PE	GNYE
Shld↵		Shld	↵

Tab. 6-17: MS2N Pin assignment terminal boxes "T"

- 1) Terminal 1, 2 are not assigned for motors without holding brake
- 2) Terminal 3, 4 are not assigned for encoder Cx, Dx. The motor temperature is transmitted via the encoder interface.
- 3) Assign not used connection wires within the terminal box.

Opening for cable insert "X"

2x M32	2x M40
MS2N10-COBHA-xxTxx-xxxxx-xx	MS2N10-DOBHA-xxTxx-xxxxx-xx
MS2N10-COBHB-xxTxx-xxxxx-xx	MS2N10-DOBHB-xxTxx-xxxxx-xx
MS2N10-COBNA-xxTxx-xxxxx-xx	MS2N10-DOBHL-xxTxx-xxxxx-xx
MS2N10-COBNB-xxTxx-xxxxx-xx	MS2N10-DOBNA-xxTxx-xxxxx-xx
MS2N10-COBNL-xxTxx-xxxxx-xx	MS2N10-DOBNB-xxTxx-xxxxx-xx
	MS2N10-DOBNL-xxTxx-xxxxx-xx
	MS2N10-EOBHA-xxTxx-xxxxx-xx
	MS2N10-EOBHB-xxTxx-xxxxx-xx
	MS2N10-EOBHL-xxTxx-xxxxx-xx
	MS2N10-EOBNA-xxTxx-xxxxx-xx
	MS2N10-EOBNB-xxTxx-xxxxx-xx
	MS2N10-FOBDA-xxTxx-xxxxx-xx
	MS2N10-FOBDB-xxTxx-xxxxx-xx
	MS2N10-FOBHA-xxTxx-xxxxx-xx
	MS2N10-FOBHB-xxTxx-xxxxx-xx

Tab. 6-18: MS2N terminal box "T" cable entry



### 6.2.8 MS2N Electrical connection "C"

View terminal box "C" power, M17 encoder (double cable connection) / rotating area

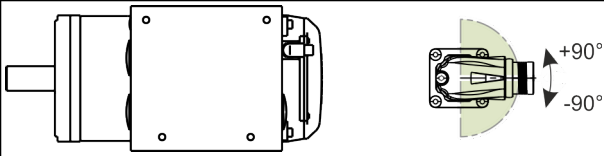
		
Connection	Power Terminal box	Encoder Flange socket
Connector size	-	M17
Output direction	A-side / B-side	rotatable (max. 10x)
Adjustment torque	-	2 ... 6 Nm
Locking	-	SpeedCon

Tab. 6-19: MS2N...-.....-..C...-.....-.. Terminal box / flange socket

### Pol pattern M17, encoder (double cable connection)

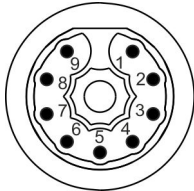
Designation	Function				
	Encoder				
	Ax	Bx	Cx	Dx	Hx
	1	+UB	+UB		
	2	n.c.	n.c.		
	3	Data+	Data+		
	4	Data-	Data-		
	5	A+	n.c.		
	6	A-	n.c.		
	7	B+	n.c.		
	8	B-	n.c.		
	9	GND	GND		

Tab. 6-20: Pin assignment pole pattern M17, encoder

Note for assembly about SpeedCon connectors, see [chapter 6.2.9 "SpeedCon connectors" on page 66](#)

Terminal boxes "C", power (double cable connection)

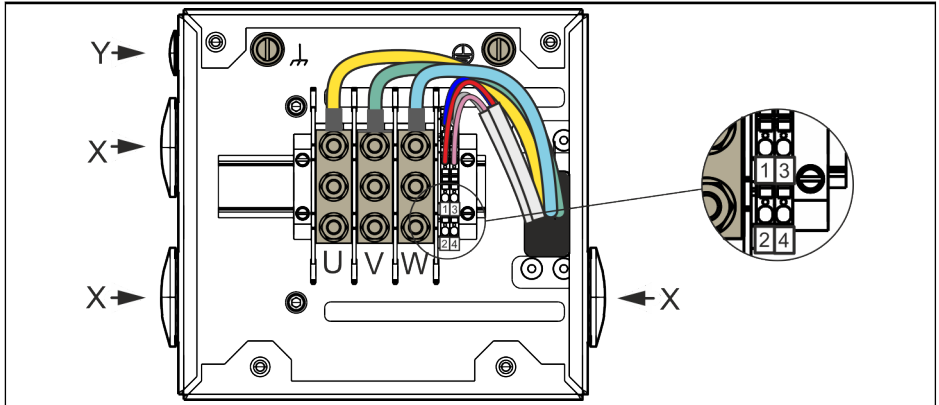

MS2N <sup>4) 5)</sup>	Clamp / data	IndraDrive	Cabel RL2 <sup>6)</sup>
U	Bolts M8, M <sub>A</sub> 6 ... 12 Nm	A1	1
V	Rated cross section 50 mm <sup>2</sup>	A2	2
W	Rated current 150 A	A3	3
1	Tension spring connection 0.5 ... 2.5 mm <sup>2</sup> with wire end ferrules	BD(+)	7
2		BD(-)	8
3		TP1(+)	5
4		TP2(-)	6
⊕	Screwed connection M8, M <sub>A</sub> 3.8 Nm	PE	GNYE
Shld ↗		Shld	↗

Tab. 6-21: MS2N Pin assignment terminal boxes "C"

Motor	Opening for cable insert "X"	Opening for cable insert "Y"
MS2N10-E0BNL-xxCxx-xxxx-xx	3x M50	1x M20
MS2N10-F0BHL-xxCxx-xxxx-xx		

Tab. 6-22: MS2N terminal boxes "C" cable entry

- 4) Terminal 1, 2 are not assigned for motors without holding brake.
- 5) Terminal 3, 4 are not assigned for encoder Cx, Dx. The motor temperature is transmitted via the encoder interface.
- 6) Assign not used connection wires within the terminal box.

## 6.2.9 SpeedCon connectors

### **⚠ WARNING**

**Damage to persons or property by disconnecting or connecting energized connectors!**

- Connect and disconnect connectors only when they are dry and de-energized.
- During operation of the system, all connectors must be securely tightened or locked.

*Observe when connecting the flange sockets:*

- Protect the flange sockets from external force effect.
- Connect the motor to ready-made connection cables.

### **Connect SpeedCon connectors**

*Properly measured ready-made connection cables are available. Plug connector type, size, wire cross section*

1. Insert power connector in position "open".

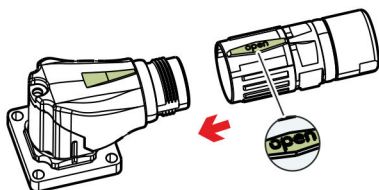

2. "Manually" tighten the power connector with a rotation by approx. 90°.

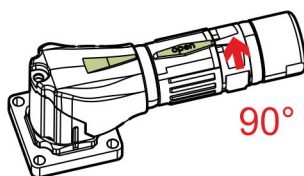

3. Check the firm seat of the SpeedCon quick lock by short pull on the connector.
4. Secure the cables, that accruing forces due to cable vibrations onto the connector are prevented.



## 6.2.10 Plug-in connector with threaded connection

### WARNING

Damage to persons or property by disconnecting or connecting energized connectors!

- Connect and disconnect connectors only when they are dry and de-energized.
- During operation of the system, all connectors must be securely tightened or locked.

*Observe when connecting the flange sockets:*

- Protect the flange sockets from external force effect.
- Connect the motor to ready-made connection cables.

### Connect the plug-in connector with the threaded connector M58

*Before connecting, please ensure properly measured ready-made connection cables are available. The type, size and cable cross section of the plug-in connector must be adjusted to the motor.*

1. Position power connector at thread.

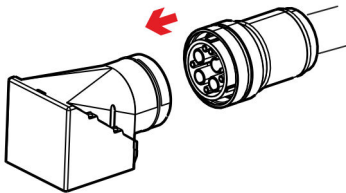

2. Tighten knurled nut "securely", in doing so, retrace cable.

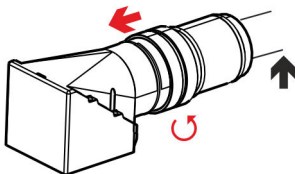

3. Check the firm seat of the SpeedCon quick lock by short pull on the connector.
4. Secure the cables, that accruing forces due to cable vibrations onto the connector are prevented.

## 6.2.11 Terminal boxes

### **WARNING**

**Danger to life by high electric voltage!**

- Follow the general installation and safety regulations when working on power installations.
- Before start-up, connect the protective conductors on all electric components according to the connection plan.
- Install the covers and guards provided for this purpose before switching on. Lock all openings of the terminal box with dummy plugs and close the terminal box with the intended terminal box lid.
- Never touch electrical connection points of the components while power is turned on.

*Observe when connecting the terminal box:*

- Connect or disconnect clamp connections only in de-energized, dry and clean state.
- Connect the motor to ready-made connection cables.
- Remove the dummy plugs "X" on the cable entry side.
- Select and tighten the cable gland according to the manufacturer's details about cable diameters.
- The connections must be established such that a permanent safe electrical connection is ensured.
- Establish a safe protective conductor connection.
- After connecting, lock all openings.



## 6.2.12 Fan unit

To connect the fan unit, use a connection cable 3 x 0.75 mm<sup>2</sup>.

MS2Nxx-xxxxA (U<sub>N</sub> 230 V)

MS2Nxx-xxxxB (U<sub>N</sub> 115 V)

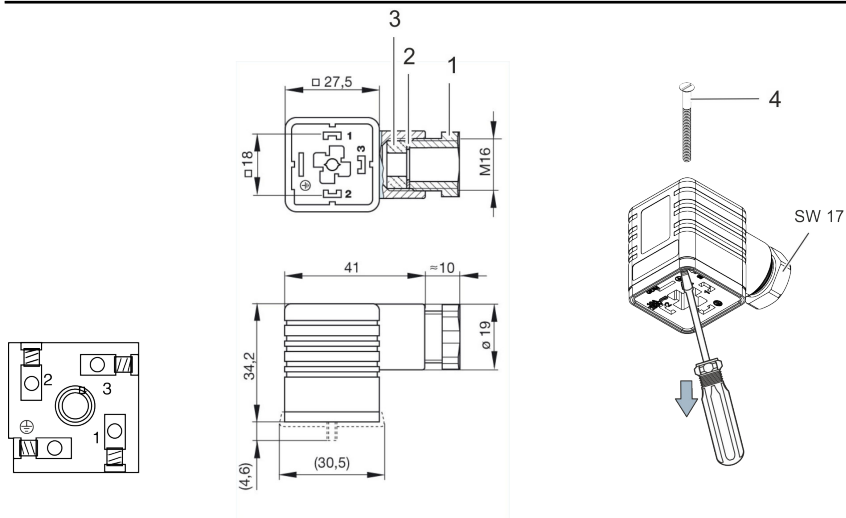

Assignment		Connection
1	L1 230 V	Screw connection 0.5 ... 1.5 mm <sup>2</sup>
2	N	
3	L1 115 V	
⊕	PE	

Tab. 6-23: Assignment of connector fan unit MS2N



The plug insert can be mounted in any position into the connector housing. Therewith, the cable output direction can be done in steps of 90 degrees.

## Mounting instruction fan connector

1. Dismantle the fan connector
  - Removing the housing screw (4)
  - Dismount plug insert
  - Loosen the cable gland and remove single parts, screwed connection (1), washer (2) and sealing (3)

2. Insert connection cable

Slide screwing (1), washer (2) and sealing (3) onto connection cable  $3 \times 0,75 \text{ mm}^2$ .

3. Connect.

Insulate cable jacket by 20 mm, the wires by 10 mm and the wires L, N, PE in the connector insert according to the assignment. Use wire end ferrules according to connection wires.

4. Mount connector

Mount the plug insert in the required cable output direction into the connector housing, tighten the cable gland and therewith create the strain relief and sealing of the connection cable. Screw the connector with housing screw (4) with counterpart

### 6.2.13 Ground connection

Optional, MS2N motors (other design "E") can be designed with an additional ground connection. An additional connection clamp is provided on the motor flange to connect the grounding conductor. The screw terminal block with clamping bracket must be assigned in a suitable way.

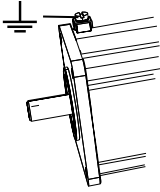
Ground connection (screw M5)	Nominal cross-section	Connectable wires	Tightening torque
	4 mm <sup>2</sup>	4 mm <sup>2</sup> (finely stranded) 6 mm <sup>2</sup> (single stranded)	2 Nm

**Tab. 6-24:** Junction for grounding conductor



### 6.3 Connection water cooling

Any installation material, like tubes or mounting clamps are not in the scope of delivery. Choose a supply hose with correct inner diameter.

#### Coolant connection

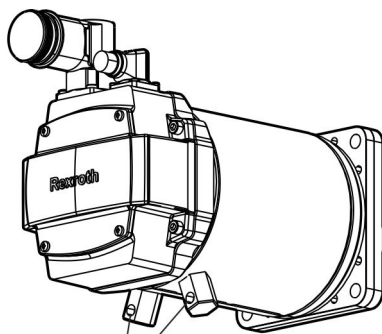

ISO 228-G 1/8

**Fig. 6-2:** Coolant connection MS2N07



The allocation of intake (IN) and outtake (OUT) can be arbitrarily done. It does not influence the power data of the motor in any way.

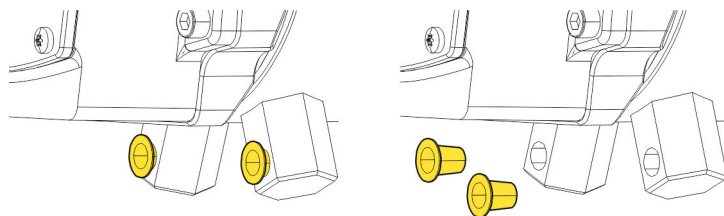

**Fig. 6-3:** Protective plug MS2N water-cooling

The connecting threads on the motor are covered with factory-attached protective caps. These protective caps may only be removed immediately before screwing in the coolant ducts to prevent dirt from entering into the cooling system.

Motor	Connection	Screw-in depth [mm]	Tightening [Nm]	torque
MS2N07	Pipe thread ISO228-G 1/8	10	14 ... 15	
MS2N10	Pipe thread ISO228-G 1/8	10	14 ... 15	

**Tab. 6-25:** Coolant connection thread, allowed tightening torques and screw-in depths



**NOTICE**

The coolant port threads on the motors may be destroyed by incorrect tightening torques!

The allowed motor connection tightening torque may not be exceeded! If the tightening torque or screw-in depth is exceeded, the motor may be damaged irreversibly.

The motor coolant connections are designed for screw connections with axial sealing.

Bosch Rexroth therefore recommends to use screw connections with an O-ring to seal the screw connection in axial direction.

Seals consisting of hemp, teflon tape or cone-shaped screw connections are not considered to be suitable, since this type of seal may stress the connection thread at the motor to an unreasonably high extent.



The machine manufacturer is responsible for ensuring that the coolant connection is tight and for verifying and accepting the tightness after the motor has been installed.

**Notes for assembly for coolant ducts**

- Fix lines in regular intervals.
- Coolant ducts must not contact live parts. Refer to "[Potential equalization](#)" on [page 15](#).

## 6.4 Sealing air connection

The sealing air connection is rotatable. The compressed air hose 4 × 0.75 is not included in the scope of delivery.

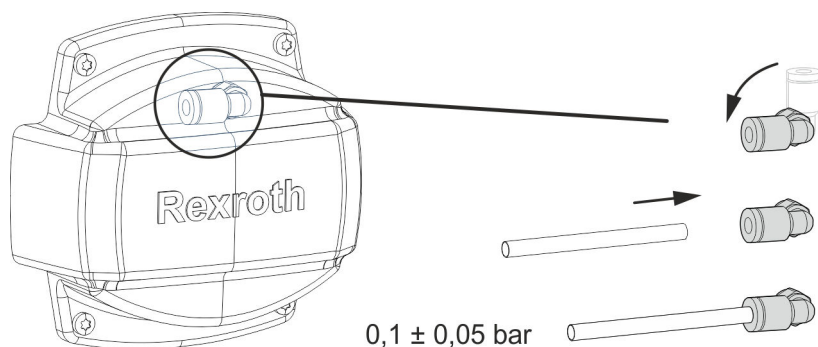

Fig. 6-4: Connection compressed air hose for using sealing air.

### **NOTICE**

**Damage due to permanent existing liquid on the shaft sealing ring!**

The use of sealing air does **not** prevent the penetration of continuously existing liquid on the shaft sealing ring (e.g. for open gearboxes). Due to capillary action, gearbox oil can penetrate into the motor and damage it, despite using sealing air.

## 7 Commissioning and operation

### WARNING

High electric voltage! Danger to life, risk of injury due to electric shock.



Live parts are dangerous.

- Do not open any covers or flange sockets during operation.
- Never connect or disconnect plug connectors under load!

### WARNING

Risk of injury due to rotating motor shaft!



- Do not remove any covers, machine parts or protection devices during operation.
- Do not enter the range of movement of the machine. Avoid unintended access for persons, due to
- Safety fences, safety screens or protective covers.
- Optical sensors

### CAUTION

Thermal danger due to hot surfaces with temperatures over 60 °C during operation



- Do not touch hot motor surfaces.
- Install protection against contact, if necessary.
- Make sure that no temperature-sensitive components (cables, electronic components, ...) touch hot surfaces.

### 7.1 Commissioning

MS2N motors can only be commissioned with other components (drive controller, control unit).

#### Prior to commissioning

Prior to commissioning, ensure that the following requirements are met.

- Storage time of the motor. Depending on the storage time, take measures to ensure safe operation. Run in bearings, resurface the holding brake, ... See [chapter 5.8 "Storage" on page 42](#).
- Ensure that all flange socket are correctly connected and protected against coming loose.
- Ensure that a holding brake voltage of 24 V  $\pm 10\%$  is applied to the motor. If necessary, adjust the voltage.

- Check the proper function of the holding brake.
- Ensure that the motor and all participating components of the drive are undamaged.
- Ensure that keys are protected against ejection.

### Commissioning

For details on the commissioning order, please refer to the respective documentation of the drive controller or firmware description.

Observe the general safety notes [chapter 2.6 "Product- and technology-dependent safety instructions "](#) on page 5.

## 7.2 Operation

During operation, keep the ambient and operation conditions and technical data specified in the project planning manual.

*Checks during operation:*

- Pay attention to exceptional noise.
- Pay attention to increased vibrations.
- Check the motor and fan units for cleanliness.
- Check the cooling water connections for tightness.
- Check the monitoring devices and diagnostic / error messages of the controllers.

**Decommission the drive when deviations from normal operation exist.** For further procedure refer to [chapter 11 "Troubleshooting "](#) on page 87.

## 8 Maintenance and repair

### WARNING

**Danger! Electric voltage! Operations in the vicinity of live parts are extremely dangerous.**



Any work required on the electric system may be carried out only by skilled electricians. Tools for electricians (VDE tools) are absolutely necessary.

*Prior to commencing work:*

1. Isolate (even auxiliary circuits).
2. Secure against reactivation.
3. Ensure de-energization.
4. Ground and short-circuit.
5. Cover or shield any adjacent live parts.

### WARNING

**Personal and material damage during maintenance work in operation!**



- Do not carry out any maintenance measures while the machine is running.
- While carrying out maintenance work, secure the machine such that it cannot restart or be used by unauthorized persons.

### CAUTION

**Hot surfaces with temperatures over 70 °C may cause burns!**



- Allow the motors to cool down prior to commencing work.
- Wear safety gloves.
- Do not work on hot surfaces.

### 8.1 Maintenance

#### Motors

Excessive dirt, chips or dust can negatively influence the motor functions. In extreme cases lead to motor loss. Clean the cooling fins of the motors at regular intervals (after one year at the latest) to reach a sufficiently high heat emission surface. If the cooling fins are partially covered with dirt, sufficient heat dissipation via the ambient air is no longer ensured.

An insufficient heat radiation may have undesired consequences. The bearing lifetime is reduced by operation at impermissibly high temperatures (the bearing

grease is decomposing). Switch-off caused by overtemperature despite operation on the basis of selected data, because the appropriate cooling is missing.

### Motors with water cooling

#### CAUTION

**Risk of injury by improper handling of pressurized lines!**

Do not attempt to disconnect, open or cut pressurized lines (risk of explosion).

- Observe the operating instructions of the manufacturers.
- Before dismantling lines, relieve pressure and empty medium.
- Use suitable protective equipment (safety gloves, safety goggles, ...).
- Immediately clean up any spilled liquids from the floor.

Check coolant water installations for damage in regular intervals and replace them, if necessary.

### Cleaning the coolant circuit

Inspect and clean (purge) the cooling system at regular intervals as specified in the machine and cooling system manufacturer's maintenance schedule.

Note that the utilization of unsuitable cleaning agents may cause irreversible damage to the motor cooling system. This type of damages does not lie within the responsibility of Bosch Rexroth.

#### **NOTICE**

**Damage to the motor cooling system due to unsuitable cleaning agents!**

- The only liquids or materials allowed to be used for cleaning and motor cooling are those which do not corrode the motor cooling system or do not react aggressively to the materials used in Bosch Rexroth motors.
- Observe the instructions of the manufacturers of the cleaning agent and the cooling system.

### Connection cables

#### WARNING

**Death by electrocution possible due to live parts!**



- Change damaged connection cables and decommission the plant immediately.
- Do not repair any connection lines provisionally.

- Check in regular distances the connection cables on damage and replace them if necessary.
- Check optionally existing drag chains (Drag chains) on defects.
- Check the protective conductor connection for proper condition and firm seating at regular intervals. Replace it, if necessary.

## 8.2 Service repair, maintenance and spare parts

Wearing parts are reliably and professionally repaired and replaced by the Bosch Rexroth Service in shopfloor-oriented quality.

The service lives of motor components, such as seals and bearings, may vary depending on the operating conditions, such as operation mode, speed, vibration and shock load, and frequent reverse mode.

We recommend to change the bearing after 30,000 operating hours. Shorter replacement intervals may be necessary; cf. checks during operation [chapter 7.2 "Operation" on page 78](#).

We recommend regular visual inspections on shaft sealing rings. Depending on operating conditions, signs of wear may appear after 5,000 operating hours. If necessary, replace the shaft sealing rings.



We recommend to have these repairs made by Bosch Rexroth Service.

---

The Bosch Rexroth service helpdesk at our headquarters in Lohr, Germany and our worldwide service provide You can contact us **24/7**.

Phone:	<b>-49 (0) 9352 40 50 60</b>
Fax	<b>-49 (0) 9352 18 49 41</b>
Email:	<a href="mailto:service.svc@boschrexroth.de">service.svc@boschrexroth.de</a>
Internet:	<a href="http://www.boschrexroth.com">http://www.boschrexroth.com</a>

### Preparing information

For quick and efficient help, please have the following information ready:

- Detailed description of the fault and the circumstances
- Information on the rating plate of the products in question, particularly type codes and serial numbers
- Your contact data (phone number, fax number, e-mail address)



## 9 Disassembly and exchange

### 9.1 Tools required

#### NOTICE

Motor damage due to strikes onto the motor shaft



- Do not strike the shaft end and do not exceed the allowed axial and radial forces of the motor.

Use suitable tools when disassembling transmission elements.

#### Pulling off

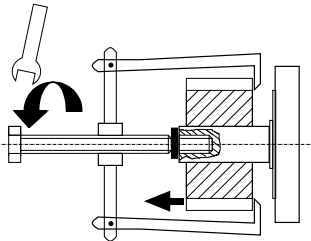

① Shim

**Fig. 9-1:** Pulling off the transmission element

Use tools suitable for pulling off. Use a shim to protect the shaft end when using pulling-off tools. Heat the output element, if necessary.

### 9.2 Exchanging the motor

#### ⚠ WARNING

Lethal electric shock by live parts with more than 50 V!

The supply unit may only be replaced by qualified personnel which have been trained to perform the work on or with electrical devices.



The motor should be replaced by a motor of identical type. Only then is ensured that the parameterization remains unchanged. Moreover, repeated acceptance within the scope of the "Integrated safety technology" is not necessary.

- If necessary, note the previous absolute value

2. Open the main switch
3. Ensure that the main switch cannot be accidentally switched on again
4. Disconnection plug connections



When exchanging the motor, close open plug sides of power connections with protection caps if moistening with coolant/lubricant or soiling must be expected (allowed soiling degree according to EN 50178: 2).

5. Exchange the motor



Observe the machine manufacturer's instructions when exchanging the motor mechanically.

6. Re-establish the plug connections
7. Re-establish the dimensional reference

### **WARNING**

**Risk of accidents due to unintentional axis movements!**

If servo axes are provided with an indirect position measuring system via the motor encoder, the dimensional reference is lost after motor replacement!

For this reason, the reference to the machine coordinate system must be re-established.

## 9.3 Preparing storage

Before motors are stored, the protection covers on flange socket, shaft and input openings for cooling water in case of liquid-cooled motors which were attached on delivery must be re-attached.

When motors are liquid-cooled, completely discharge the coolant from the cooling tubes (e.g., via purging the coolant holes with pressure air). This will prevent frost damage at storage temperatures lower than 0 °C.

## 10 Environmental protection and disposal

### Production processes

The products are manufactured in energy- and resource-optimized production processes which allow re-using and recycling the resulting waste. We regularly try to replace pollutant-loaded raw materials and supplies by more environment-friendly alternatives.

### No release of hazardous substances

Our products do not contain any hazardous substances which may be released in case of appropriate use. Normally, our products will not have any negative influences on the environment.

### Significant components

Basically, our motors consist of the following components: Steel, aluminum, copper, brass, permanent magnets (rare earth metal), electronic components.

### Return of products

Our products can be returned to us for disposal free of charge. However, this requires that the products be free from oil, grease or other dirt.

Furthermore, the products returned for disposal may not contain any undue foreign material or foreign components.

Deliver the products "free domicile" to the following address:

Bosch Rexroth AG  
Electric Drives and Controls  
Buergermeister-Dr.-Nebel-Straße 2  
97816 Lohr am Main, Germany

### Permanent magnets

Permanent magnets present a serious danger during disposal.

---

**⚠ WARNING****Danger due to permanent magnets!**

- Health hazard for persons with heart pacemakers, metallic implants and hearing aids in direct environment of permanent magnets.



- Crushing hazard of fingers and hand due to heavy attractive forces of the magnets.



- Risk of destruction of sensitive parts like watches, credit cards, ...
-

**Before disposal, permanent magnets must be demagnetized. This can be reached by thermal conditioning. The transport of magnetized rotors is forbidden.**

### Packaging

Packaging materials consist of cardboard, wood and polystyrene. They can be recycled anywhere without any problem.

For ecological reasons, please refrain from returning the empty packages to us.

### Batteries and accumulators

Batteries and accumulators can be labeled with this symbol.



The symbol indicating "separate collection" for all batteries and accumulators is the crossed-out wheeled bin.

End users in the EU are legally bound to return used batteries. Outside the validity of the EU Directive 2006/66/EC, the particularly applicable regulations must be followed.

Used batteries can contain hazardous substances which can harm the environment or people's health when improperly stored or disposed of.

After use, the batteries or accumulators contained in Rexroth products must be properly disposed of according to the country-specific collection systems.

### Recycling

Most of the products can be recycled due to their high content of metal. In order to recycle the metal in the best possible way, the products must be disassembled into individual assemblies.

Metals contained in electric and electronic assemblies can also be recycled by means of special separation processes.

Plastic parts of the products may contain flame retardants. These plastic parts are labeled according to EN ISO 1043. They have to be recycled separately or disposed of according to the applicable legal provisions.

# 11 Troubleshooting

## 11.1 Troubleshooting procedure

As a matter of principle, the instructions in the project planning and commissioning manuals must be followed in case of failures and errors. Contact the manufacturer, if necessary.

Malfunctions	Error cause	Measures
Motor does not run	Controller enable signal missing	Activate controller enable signal
	Controller fault	Troubleshoot acc. to documentation of controller
	Voltage supply missing	Control voltage supply
	Brake is not released	Check the brake activation
Vibrations	Coupling elements or attachments are poorly balanced	Re-balance
	Adjustment of shaft end attachments (coupling, gearbox, ...) is insufficient	Re-align the attachments
	Mounting screws loose	Lock screw connections acc. to specifications
Running noise	Foreign bodies within the motor	Stop the motor --> repair by manufacturer
	Bearing is damaged	Stop the motor --> repair by manufacturer
High motor temperatures Motor temperature monitoring is activated	Operation outside of rated data	Reduce load and check the dimensioning
	Heat dissipation is impaired	Clean the motor Clean the grille of the fan unit and check the function of the fan Check the coolant circuit of liquid cooling systems
Wrong or defective temperature display	Temperature sensor not connected	Connect temperature sensor
	Temperature sensor defective	Stop the motor --> repair by manufacturer Change the temperature sensor. Connect the backup temperature sensor, if any is available.

**Tab. 11-1:** Measure at malfunction

## 12 Technical data

Technical data with operating characteristic curves are described in the project planning manual for all motor types. Please, refer to the following documentation for relevant information.

	Title	Document type	Document number
	Rexroth IndraDyn S Synchronous Motors MS2N	Project planning manual	DOK-MOTOR*-MS2N*****.PR.....P

**Tab. 12-1:** Additional documentation

## 13 Appendix

### 13.1 EU-Declaration of conformity

According to **Low voltage directive 2014/35/EU**, the vendor

**Bosch Rexroth AG**

**Buergermeister-Dr.-Nebel-Straße 2**

**97816 Lohr am Main, Germany**

hereby declares that the product below

#### 3~ PM motor

MS2N03...	MS2N04...	MS2N05...
MS2N06...	MS2N07...	MS2N10...

From the date of manufacture 2016-04-20 were developed, designed and manufactured in compliance with the above-mentioned EU directive.

Harmonized standards applied:

Standard	Title	Edition
EN 60034-1 (IEC 60034-1)	Rotating electrical machines - Part 1: Rating and performance	2010 + Cor.:2010 (2010, modified)
EN 60034-5 (IEC 60034-5)	Rotating electrical machines - Part 5: Degrees of protection provided by integral design of rotating electrical machines (IP-Code) - Classification	2001 + A1:2007 (2000 + Corrigendum 2001 + A1:2006)

Further explanations: None



**EU-Konformitätserklärung - Original**

Dok.-Nr.: DCTC-30318-002

Datum: 2016-04-20

- nach Maschinenrichtlinie 2006/42/EG
- nach Niederspannungsrichtlinie 2014/35/EU
- nach EMV-Richtlinie 2014/30/EU
- nach ATEX-Richtlinie 2014/34/EU

Hiermit erklärt der Hersteller,  
Bosch Rexroth AG  
Bürgermeister-Dr.-Nebel-Straße 2  
97816 Lohr am Main / Germany,

dass die nachstehenden Produkte

Bezeichnung: 3- PM-MOTOR  
Baureihen: MS2N03... MS2N04... MS2N05...  
MS2N06... MS2N07... MS2N10...  
Ab Herstelldatum: 2016-04-20

in Übereinstimmung mit den oben genannten EU-Richtlinien entwickelt, konstruiert und gefertigt wurden.

Angewandte harmonisierte Normen:

Norm	Titel	Ausgabe
EN 60034-1 (IEC 60034-1)	Drehende elektrische Maschinen – Teil 1: Bemessung und Betriebsverhalten	2010 + Cor.:2010 (2010, modifiziert)
EN 60034-5 (IEC 60034-5)	Drehende elektrische Maschinen – Teil 5: Schutzarten aufgrund der Gesamtkonstruktion von drehenden elektrischen Maschinen (IP-Code) –Einteilung	2001 + A1:2007 (2000 + Corrigendum 2001 + A1:2006)

© Bosch Rexroth AG 2016

DCTC-30318-002\_LOE\_N\_DE\_2016-04-20.docx

Lohr am Main , den 2016-04-20 ppa.  i.V.   
Ort Datum Werkleitung LoP2 Entwicklungsbereichsleiter Antriebe

Änderungen im Inhalt der EU-Konformitätserklärung sind vorbehalten. Derzeit gültige Ausgabe auf Anfrage.

**Fig. 13-1:** EU-Declaration of conformity - origin, German





**EU declaration of conformity - original**

Doc. No.: DCTC-30318-002

Date: 2016-04-20

- in accordance with Machinery Directive 2006/42/EC
- in accordance with Low Voltage Directive 2014/35/EU
- in accordance with EMC Directive 2014/30/EU
- in accordance with ATEX Directive 2014/34/EU

The manufacturer,  
Bosch Rexroth AG  
Bürgermeister-Dr.-Nebel-Straße 2  
97816 Lohr am Main / Germany

hereby declares that the products below

Name: 3- PM-MOTOR  
Series: MS2N03... MS2N04... MS2N05...  
MS2N06... MS2N07... MS2N10...

From the date of manufacture: 2016-04-20

were developed, designed and manufactured in compliance with the above-mentioned EU directives.

Harmonized Standards applied:

Standard	Title	Edition
EN 60034-1 (IEC 60034-1)	Rotating electrical machines – Part 1: Rating and performance	2010 + Cor.:2010 (2010, modified)
EN 60034-5 (IEC 60034-5)	Rotating electrical machines – Part 5: Degrees of protection provided by integral design of rotating electrical machines (IP code) - Classification	2001 + A1:2007 (2000 + Corrigendum 2001 + A1:2006)

© Bosch Rexroth AG 2016

DCTC-30318-002\_KOE\_N\_EN\_2016-04-20.docx

Lohr am Main, dated 2016-04-20  
 Place Date  
  
 Joachim Hennig  
 Plant Manager LoP2  
  
 Eberhard Schemm  
 Head of Development Drives Solutions

We reserve the right to make changes to the content of the EU Declaration of Conformity. Current issue on request.

**Fig. 13-2:** EU-Declaration of conformity - origin, English

## 13.2 UL / CSA

The UL/CSA conformity of MS2N motors can be found on the type plate of the motors. The following symbol is used for identification purposes: . The MS2N motor listing with the UL file number E335445 can be found under [www.ul.com](http://www.ul.com)

## 13.3 China RoHS 2

[www.boschrexroth.com.cn/zh/cn/home\\_2/china\\_rohs2](http://www.boschrexroth.com.cn/zh/cn/home_2/china_rohs2)

## Index

### A

Accumulators.....	86
Air-pressure connector kit.....	76
Alignment.....	27
Ambient conditions.....	36
Ambient temperature.....	36
Attachments.....	21

### B

Balance.....	46
Balancing.....	19, 20
Batteries.....	86
Bearing.....	28
Axial force.....	30
Bearing service life.....	29
Radial force.....	30
Bevel gear pinion.....	22

### C

CE.....	89
Centering collar.....	11
Climatic conditions.....	36
Coating.....	31
Concentricity.....	27, 28
Conformity.....	89
Connection cables.....	81
Connection electrically.....	72
Connection water cooling.....	74
Contained substances see "Significant components".....	85
Coolant Corrosion protection.....	15
Coolant connection.....	74
Cooling fins.....	79
Cooling mode (see motor cooling).....	13
Cooling system.....	15
Coupling.....	21, 46
CSA.....	92

### D

Degree of protection.....	4, 19
Disposal.....	85
Drag chains.....	81

### E

Encoder.....	18
EU-Declaration of conformity.....	89
Exchanging the motor.....	83
Extension elements.....	19

### F

Fan.....	70
Flange Alignment.....	28
Concentricity.....	27, 28
Flange exactness.....	27
Forced ventilation.....	14
Frame size.....	30
Functional safety.....	18

### G

Gearbox mounting.....	21
Ground connection.....	72

### H

Half key balancing .....	20
Hazardous substances.....	85
Heat dissipation.....	79
Helical teeth.....	22
Holding brake Commissioning.....	26
electrically-released.....	23
Hole circle.....	11

### I

IM-code EN 60034-7.....	30
Installation altitude.....	36
Installation type.....	30
Intended use.....	4
IP degree of protection.....	19
IP-Code EN 60034-5.....	19

### L

Length.....	11
Lifting eye bolts.....	41
Lifting tools.....	41
Long term storage.....	43
Long-term storage.....	42

<b>M</b>		<b>T</b>	
Minimum distance.....	13, 14	Temperature sensor.....	12
Motor cooling.....	13	Transmission element.....	46
Coolant temperature.....	16	Fitting.....	47
Coolants.....	15	Pulling off.....	83
Forced ventilation IC416.....	14	Transport.....	36, 40, 41
Self-cooling IC410.....	13	Troubleshooting.....	87
Motor temperature.....	12	Type code.....	34
Mounting hole.....	11	Type plate.....	34
<b>O</b>		<b>U</b>	
Operating conditions.....	36	UL.....	92
Operation.....	36	Unintended use.....	4
Operation on foreign convert- ers.....	44	<b>V</b>	
Oscillations.....	39	Vibration.....	28, 39
Output shaft.....	19	<b>W</b>	
Overdetermined bearing.....	21	Warning temperature.....	12
<b>P</b>		Water cooling.....	74
Packaging.....	86	IC3W7.....	15
Permanent magnets.....	85		
Production processes.....	85		
Pulley.....	46		
Pulling off the transmission ele- ment.....	83		
<b>R</b>			
Rating and performance.....	4		
Recycling.....	86		
Return of products.....	85		
RoHS			
China RoHS 2.....	92		
<b>S</b>			
Self-cooling.....	13		
Service.....	82		
Shaft.....	11		
smooth.....	19		
with key way.....	19		
Shaft length.....	11		
Shock.....	40		
Shutdown temperature .....	12		
Significant components.....	85		
Sound pressure level.....	33		
Storage.....	36, 42		

## Notes

**Bosch Rexroth AG**

Electric Drives and Controls

P.O. Box 13 57

97803 Lohr, Germany

Bgm.-Dr.-Nebel-Str. 2

97816 Lohr, Germany

Phone +49 9352 18 0

Fax +49 9352 18 8400

[www.boschrexroth.com/electrics](http://www.boschrexroth.com/electrics)



R911347581