



Advanced Product Data

WeatherExpert®

Packaged High Outdoor Air Systems

6 to 10 Nominal Tons

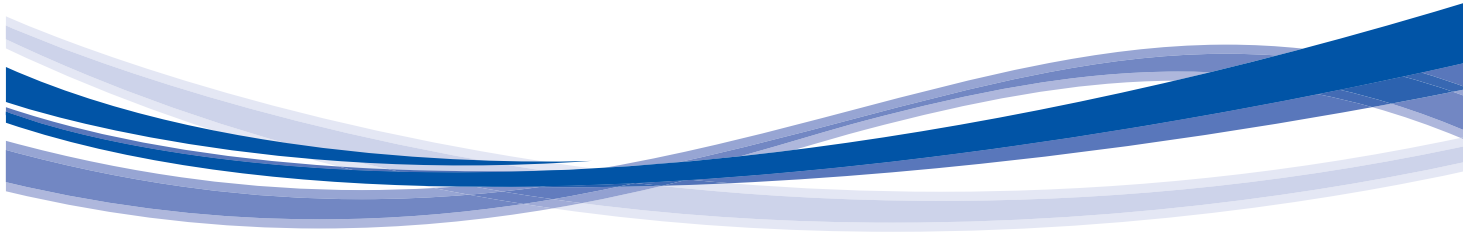

WeatherExpert™



48LC*H Sizes 07-12

Packaged Direct Expansion (DX) Cooling With Gas Heat

50LC*H Sizes 07-12

Packaged Direct Expansion (DX) Cooling With No Heat or Electric Heat

Carrier's WeatherExpert® packaged high outdoor air systems offer high efficiency, application flexibility, and rugged performance, while being easy to install, simple to maintain, and delivering the reliability you expect from Carrier.

The Carrier WeatherExpert 48/50LC*H packaged high outdoor air system is a special configuration of the Carrier WeatherExpert 48/50LC packaged rooftop unit that has been optimized for use in applications requiring high percentages of outdoor air (up to 100%). The 48/50LC*H optimization includes the addition of new features and options, such as modulating hot gas reheat, modulating heat, and a low-load protection valve, that allows the unit to operate at a wide range of

entering air conditions and airflows needed for high outdoor air operation. Carrier SmartVu™ controls have also been added to provide operation of the new modulating components and allow the control flexibility needed for use in a variety of high outdoor air applications.

NOTE: This document is an advanced release product data. The information contained within is subject to change, deletion or notation.

WeatherExpert®

High Outdoor Air System

Carrier SmartVu™ Controls

- 7" touchscreen display
- Flexible configuration
- Standalone, thermostat or networked operation
- Carrier i-Vu® compatible

EcoBlue™ Indoor Fan

- Vane axial blower
- Direct drive ECM motor
- Medium or high static motors
- No belts or pulleys
- Multiple control methods

Refrigerant Circuit

- 6, 7.5, and 10 ton capacities
- High efficiency design
- Three compressor stages
- Modulating low load valve
- Puron® (R-410A) refrigerant

Indoor Air Coils

- Large face area Al/Cu evaporator coil
- Hot gas reheat (HGRH) coil with modulating control
- Optional coated coils

Construction

- Galvanized construction
- Painted exterior
- Hinged access panels
- Heavy gauge base rail
- Optional double wall construction

Outdoor Air/Exhaust

- Ultra Low Leak economizer with barometric relief
- 100% outdoor air or mixed air operation

Electric Heat (50 Series)

- High temperature rise design
- Multiple capacity options
- Silicon rectifier (SCR) modulating control

Gas Heat (48 Series)

- High temperature rise stainless steel heat exchanger
- Multiple capacity options
- 5:1 turndown or 10:1 modulating control

Table of contents

| | Page |
|--|------|
| Overview | 2 |
| Features/Benefits | 3 |
| Model Number Nomenclature | 5 |
| Performance Ratings | 7 |
| Physical Data | 9 |
| Options and Accessories | 12 |
| Dimensions | 17 |
| Performance Data | 40 |
| Fan Data | 45 |
| Electrical Data | 49 |
| Typical Wiring Diagrams | 53 |
| Controls | 56 |
| Application Data | 65 |
| Equipment Sizing and Options | 71 |
| Guide Specifications | 74 |

High efficiency

WeatherExpert® units are designed with efficiency in mind. Full load cooling efficiencies of up to 13.1 EER are achieved using efficient scroll compressors, large face area evaporator and condenser coils, and high efficiency electronically communicated condenser fan motors (ECM).

Heating, ventilation, and air conditioning (HVAC) units, including high outdoor air systems, spend most of their operating life at less than full load conditions, so part-load efficiency is very important. All WeatherExpert units feature a fully active evaporator coil, three compressor stages, and modulated condenser fan operation to achieve a part-load cooling efficiency of up to 20.8 IEER.

WeatherExpert high outdoor air units are equipped with an EcoBlue™ vane axial supply fan with direct drive ECM motor to provide efficient operation over a wide range of airflows.

Application flexibility

The 48/50LC*H unit is selectable between 6, 7.5, and 10 ton nominal cooling capacities in multiple voltages to meet project requirements. All units are equipped with an EcoBlue supply fan, which is selectable with a medium static (up to 2 in. wg external) or high static (up to 3 in. wg external) motor. Multiple supply fan control methods are available as standard, including constant volume (CV), staged air volume (SAV™), and third-party modulating control.

Flexibility has also been built into the Carrier SmartVu™ controls on every 48/50LC*H unit. The controls can be configured for use in a wide variety of applications including single-zone space air conditioning, make-up air, or as a unitary dedicated outdoor air system (DOAS).

The Carrier SmartVu control can be configured to operate the unit between 0 and 100% outdoor air operation with either fixed or modulating damper control. Stand-alone cooling, heating, and dehumidification operation can be field configured to operate based on a wide variety of control inputs, including space conditions, or outdoor air conditions.

The Carrier SmartVu control can also accommodate third-party control, based on customer needs. The unit can be configured for control using a standard 2-stage cool/heat thermostat for easy user operation. More demanding applications can be configured for hardwired or network control of unit

demand and modulation of key components.

Rugged performance

Conditioning high quantities of outdoor air is no easy task, and the 48/50LC*H unit is up to the challenge. The standard EcoBlue direct drive vane axial supply fan is capable of operating between 130 and 350 cfm/ton at up to 3 in. wg external static pressure.

The 48/50LC*H refrigeration circuit has been designed to operate in a wide range of conditions with mechanical cooling being available at up to, 125°F (51.6°C) and down to 40°F (4°C) ambient.

Mechanical dehumidification operation is possible up to 115°F (46°C) ambient with up to 105°F (40.5°C) entering the evaporator, and down to 60°F (15°C) ambient entering evaporator. Free cooling at low ambient conditions is possible with the factory or field-installed economizer.

Cooling and dehumidification can operate at a wide range of airflows, including 175 to 350 cfm/ton full load, and down to 130 cfm/ton at the lowest stage of operation.

Easy to install

All WeatherExpert high outdoor air systems feature heavy duty, full perimeter base rails with fork pockets and lifting holes to make moving and rigging the unit easy.

The Carrier SmartVu control is factory-wired and programmed, saving on installation time and cost. Control interface is accomplished through the included 7 in. touchscreen interface, making setup and configuration a breeze.

The Carrier SmartVu control includes an available component test mode and service run mode to test the cooling, dehumidification, heating, and fan systems to help make equipment start-up easy.

Simple to maintain and service

All 48/50LC*H units include hinged access panels with quarter turn latches and lifting tabs to provide easy access to maintain or service key components; such as filters, compressors, supply fan, or controls.

The Carrier SmartVu control also makes maintenance and service easy by providing reminders when maintenance items, like filter changes, are overdue, or by providing alerts and

alarms to indicate when service may be needed.

Factory-installed discharge and suction pressure sensors can allow the user to monitor the refrigerant circuit from the SmartVu control interface or using network points, minimizing the need to connect refrigerant gauges for troubleshooting.

The reliability you expect

Carrier conducts rigorous testing to ensure each unit will perform as designed. The 48/50LC*H unit has been tested in Carrier's psychometric labs and in third party labs to verify unit operation and performance. All units compete a run test and quality check to verify system operation prior to shipment.

Condensate drain pans are made of non-corrosive composite material to help combat corrosion from moisture. Motors are permanently lubricated and metering devices are thermostatic valve style (TXV) to support reliable operation. In addition, the compressors use crankcase heaters, which further enhance the unit's reliability in cold weather climates. All units are backed by Carrier's 5-year compressor parts warranty, 15-year stainless steel heat exchanger parts warranty, and 1-year warranty on all other non-consumable parts. Extended parts and labor warranties are available.

Full standard features

Construction:

- Heavy duty galvanized base rail with rigging points and fork slots
- Galvanized steel posts, side panels, top panel, and base pan
- Pre-painted exterior panels and primer-coated interior panels tested up to 500 hours salt spray protection
- Hinged access panels with quarter turn latches and lifting handles on key service areas
- Easy starting, no-strip screw feature on unit panels
- Fully insulated with foil-faced insulation (R4) throughout the entire air stream of the cabinet
- 2 in. filter track with installed throwaway fiberglass filters
- Corrosive-resistant composite condensate pan is in accordance with ASHRAE standard 62 for sloped design, and includes provisions for side or bottom drain connection

Features/benefits (cont)



Electrical:

- Available in 208/230v-3Ph, 460v-3Ph, and 575v-3Ph
- Single point electric connection
- Terminal block
- 5kA short circuit current rating (SCCR)

Controls:

- Carrier SmartVu™ controls included on all units
- 7 in. touchscreen display
- Supply air temperature based control
- Standalone operation with occupancy schedule
- Hardwired occupancy switch or network occupancy control
- CCN or BACnet¹ communication
- Plug and play with Carrier i-Vu™ 8.0+ web-based operator interface
- Factory-installed OAT, OARH, RAT, RARH, and CCT sensors
- Factory provided, field-installed SAT sensor
- Configurable for cooling/heating based on OAT or SPT, dehumidification based on RARH, SPRH, or OADP
- CV, SAV, or third party supply fan control
- Hardwired and network inputs for thermostat or third-party control of cooling, heating, and dehumidify demand
- Hardwired and network analog inputs for third-party control of modulating control of supply fan, exhaust fan, and outdoor air damper

- Factory-installed condensate overflow switch
- Additional control discrete inputs for fire shutdown/smoke detector, remote shutdown/occupancy switch, phase monitor, and filter status
- Additional control analog inputs for indoor air quality, space temperature offset, mixed air temperature and building pressure
- Additional control outputs for damper override relay (formerly heat interlock relay), alarm indicator, single stage or modulating power exhaust control

Cooling and dehumidification:

- Nominal 6, 7.5, and 10 ton capacities (unit sizes 07-12)
- Cooling IEER up to 20.8 and EERs up to 13.1
- Certified performance to AHRI standard 340/360
- Single circuit refrigerant system with factory charged Puron® refrigerant (R-410A)
- 3-stage cooling capacity with uneven tandem scroll compressors
- TXV refrigerant metering device
- Modulating low load protection valve
- Large face area, Al/Cu evaporator coil for maximized cooling and dehumidification performance, even at part load operation
- Al/Cu condenser coil for maximized efficiency
- Totally enclosed ECM outdoor fan motor with permanently lubricated bearings and modulated operation
- High ambient cooling operation up to 125°F (51.6°C)
- Low ambient mechanical cooling operation down to 40°F (4°C)

- Crankcase heater on each compressor designed to cycle off when the compressor is in use
- High capacity liquid line filter drier
- Factory-installed refrigerant circuit discharge and suction line pressure sensors readable from the SmartVu™ interface or network points
- High refrigerant pressure switch
- Large face area, Al/Cu hot gas reheat coil
- Fully modulating hot gas reheat control valve
- Dehumidification operation up to 115°F (46°C) ambient and down to 60°F (16°C) ambient
- Dehumidification capability up to 105°F (40.5°C) and down to 60°F (16°C) entering evaporator temperatures

Supply fan:

- EcoBlue™ Technology supply fan
- Vane axial fan with direct drive ECM motor
- Medium or high static fan motor
- Constant volume (CV), staged air volume (SAV™), or third party modulating Vertical supply and return duct connections
- Field convertible airflow capability (requires accessory on sizes 08-12)

Warranty:

- 5-year compressor parts
- 15-year stainless steel gas heat exchanger
- 1-year non-consumable parts

1. Third-party trademarks and logos are the property of their respective owners.



Use of the AHRI Certified TM Mark indicates a manufacturer's participation in the program. For verification of certification for individual products, go to www.ahridirectory.org.

48LC*H Model Number Nomenclature

| | | | | | | | | | | | | | | | | | | |
|-----------|---|---|---|---|---|---|---|---|---|----|----|----|----|----|----|----|----|----|
| Position: | 1 | 2 | 3 | 4 | 5 | 6 | 7 | 8 | 9 | 10 | 11 | 12 | 13 | 14 | 15 | 16 | 17 | 18 |
| Example: | 4 | 8 | L | C | 4 | H | 0 | 7 | J | J | A | 1 | A | Z | A | 3 | A | 1 |

Heat Type

48 - Packaged DX Cooling with Gas Heat

Model Series

LC - WeatherExpert®

Heat Option

- 4 - Low Modulating Gas Heat - Standard Turndown (5:1 NG/3:1 LP)
- 5 - Medium Modulating Gas Heat - Standard Turndown (5:1 NG/3:1 LP)
- 6 - High Modulating Gas Heat - Standard Turndown (5:1 NG/3:1 LP)
- 8 - Medium Modulating Gas Heat - High Turndown (10:1 NG/6:1 LP)
- 9 - High Modulating Gas Heat - High Turndown (10:1 NG/6:1 LP)

Refrigeration System

H - High Outdoor Air System (Modulating HGRH, Low Load Valve)

Nominal Cooling Capacity

- 07 - 6 Tons
- 08 - 7.5 Tons
- 12 - 10 Tons

Sensor Options

- J - Condensate Overflow Switch (COFS)
- K - COFS + Return Air Smoke Detector (RA SD)
- L - COFS + RA SD + Supply Air Smoke Detector (SA SD)
- M - COFS + CO₂ Sensor (CO₂)
- N - COFS + CO₂ + RA SD
- P - COFS + CO₂ + SA SD
- Q - COFS + CO₂ + RA SD + SA SD
- Z - COFS + SA SD

Indoor Fan Options and Supply/Return

- J - Medium Static + CV/SAV Control + Vertical Supply/Return
- K - High Static + CV/SAV Control + Vertical Supply/Return
- N - Medium Static + Duct Pressure Control + Vertical Supply/Return
- P - High Static + Duct Pressure Control + Vertical Supply/Return
- S - Medium Static + Zone Pressure Control + Vertical Supply/Return
- T - High Static + Zone Pressure Control + Vertical Supply/Return

Packaging and Construction Options

- 1 - LTL
- 5 - LTL + Double Wall Construction

Electrical Options

- A - None
- B - HACR Circuit Breaker (CB)
- C - Non-Fused Disconnect (NFD)
- D - Thru-the-Base Gas and Electric (TTB)
- E - CB + TTB
- F - NFD + TTB

Service Options

- 3 - Hinged Panels (HgPI)
- 4 - HgPI + Non-Powered Convenience Outlet (NPCO)
- 5 - HgPI + Powered Convenience Outlet (PCO)
- A - HgPI + 4" MERV 8 Filter
- B - HgPI + 4" MERV 8 Filter + NPCO
- C - HgPI + 4" MERV 8 Filter + PCO
- D - HgPI + 4" MERV 13 Filter
- F - HgPI + 4" MERV 13 Filter + NPCO
- G - HgPI + 4" MERV 13 Filter + PCO

Outdoor Air Options

- A - None
- R - Ultra Low Leak Enthalpy Economizer + Barometric Relief

Controls

- Z - SmartVu Controls

Design Release

- A - Initial

Voltage

- 1 - 575V-3Ph-60Hz
- 5 - 208V/230V-3Ph-60Hz
- 6 - 460V-3Ph-60Hz

Coil Options

- A - Al/Cu Condenser + Al/Cu Indoor Coils
- B - Pre-Coat Al/Cu Condenser + Al/Cu Indoor Coils
- C - E-Coat Al/Cu Condenser + Al/Cu Indoor Coils
- D - E-Coat Al/Cu Condenser + E-Coat Al/Cu Indoor Coils
- M - Al/Cu Condenser + Hailguard + Al/Cu Indoor Coils
- N - Pre-Coat Al/Cu Condenser + Hailguard + Al/Cu Indoor Coils
- P - E-Coat Al/Cu Condenser + Hailguard + Al/Cu Indoor Coils
- Q - E-Coat Al/Cu Condenser + Hailguard + E-Coat Al/Cu Indoor Coils

Model number nomenclature (cont)



50LC*H Model Number Nomenclature

| | | | | | | | | | | | | | | | | | | |
|-----------|---|---|---|---|---|---|---|---|---|----|----|----|----|----|----|----|----|----|
| Position: | 1 | 2 | 3 | 4 | 5 | 6 | 7 | 8 | 9 | 10 | 11 | 12 | 13 | 14 | 15 | 16 | 17 | 18 |
| Example: | 5 | 0 | L | C | 2 | H | 0 | 7 | J | J | A | 1 | A | Z | A | 3 | A | 1 |

Heat Type

50 - Packaged DX Cooling,
No Heat or Electric Heat

Model Series

LC - WeatherExpert®

Heat Option

0 - No Heat
2 - Medium Modulating Electric Heat - SCR Control
3 - High Modulating Electric Heat - SCR Control

Refrigeration System

H - High Outdoor Air System (Modulating HGRH, Low Load Valve)

Nominal Cooling Capacity

07 - 6 Tons
08 - 7.5 Tons
12 - 10 Tons

Sensor Options

J - Condensate Overflow Switch (COFS)
K - COFS + Return Air Smoke Detector (RA SD)
L - COFS + RA SD + Supply Air Smoke Detector (SA SD)
M - COFS + CO₂ Sensor (CO₂)
N - COFS + CO₂ + RA SD
P - COFS + CO₂ + SA SD
Q - COFS + CO₂ + RA SD + SA SD
Z - COFS + SA SD

Indoor Fan Options and Supply/Return

J - Medium Static + CV/SAV Control + Vertical Supply/Return
K - High Static + CV/SAV Control + Vertical Supply/Return
N - Medium Static + Duct Pressure Control + Vertical Supply/Return
P - High Static + Duct Pressure Control + Vertical Supply/Return
S - Medium Static + Zone Pressure Control + Vertical Supply/Return
T - High Static + Zone Pressure Control + Vertical Supply/Return

Coil Options

A - Al/Cu Condenser + Al/Cu Indoor Coils
B - Pre-Coat Al/Cu Condenser + Al/Cu Indoor Coils
C - E-Coat Al/Cu Condenser + Al/Cu Indoor Coils
D - E-Coat Al/Cu Condenser + E-Coat Al/Cu Indoor Coils
M - Al/Cu Condenser + Hailguard + Al/Cu Indoor Coils
N - Pre-Coat Al/Cu Condenser + Hailguard + Al/Cu Indoor Coils
P - E-Coat Al/Cu Condenser + Hailguard + Al/Cu Indoor Coils
Q - E-Coat Al/Cu Condenser + Hailguard + E-Coat Al/Cu Indoor Coils

Packaging and Construction Options

1 - LTL
5 - LTL + Double Wall Construction

Electrical Options

A - None
B - HACR Circuit Breaker (CB)
C - Non-Fused Disconnect (NFD)
D - Thru-the-Base Gas and Electric (TTB)
E - CB + TTB
F - NFD + TTB

Service Options

3 - Hinged Panels (HgPI)
4 - HgPI + Non-Powered Convenience Outlet (NPCO)
5 - HgPI + Powered Convenience Outlet (PCO)
A - HgPI + 4" MERV 8 Filter
B - HgPI + 4" MERV 8 Filter + NPCO
C - HgPI + 4" MERV 8 Filter + PCO
D - HgPI + 4" MERV 13 Filter
F - HgPI + 4" MERV 13 Filter + NPCO
G - HgPI + 4" MERV 13 Filter + PCO

Outdoor Air Options

A - None
R - Ultra Low Leak Enthalpy Economizer + Barometric Relief

Controls

Z - SmartVu Controls

Design Release

A - Initial

Voltage

1 - 575V-3Ph-60Hz
5 - 208V/230V-3Ph-60Hz
6 - 460V-3Ph-60Hz

Performance ratings



48LC** 07-12 Cooling Ratings (208-v)^{a,b,c}

| UNIT SIZE | COOLING STAGES | MOTOR OPTION | NOMINAL CAPACITY (TONS) | COOLING CAPACITY (MBH) | TOTAL POWER (kW) | EER | IEER | RATED INDOOR AIRFLOW (cfm) |
|-----------|----------------|--------------|-------------------------|------------------------|------------------|------|------|----------------------------|
| 07 | 3 | — | 6.0 | 70.0 | 5.4 | 13.0 | 20.5 | 2250 |
| 08 | 3 | Medium | 7.5 | 89.0 | 7.0 | 12.8 | 19.4 | 2625 |
| | | High | 7.5 | 89.0 | 7.0 | 12.8 | 19.4 | 2625 |
| 12 | 3 | — | 10.0 | 116.0 | 8.9 | 13.0 | 20.6 | 3500 |

50LC** 07-12 Cooling Ratings (208-v)^{a,b,c}

| UNIT SIZE | COOLING STAGES | MOTOR OPTION | NOMINAL CAPACITY (TONS) | COOLING CAPACITY (MBH) | TOTAL POWER (kW) | EER | IEER | RATED INDOOR AIRFLOW (cfm) |
|-----------|----------------|--------------|-------------------------|------------------------|------------------|------|------|----------------------------|
| 07 | 3 | — | 6.0 | 70.0 | 5.3 | 13.1 | 20.7 | 2250 |
| 08 | 3 | Medium | 7.5 | 89.0 | 6.9 | 13.0 | 19.4 | 2625 |
| | | High | 7.5 | 89.0 | 7.0 | 12.9 | 19.3 | 2625 |
| 12 | 3 | — | 10.0 | 116.0 | 8.9 | 13.1 | 20.8 | 3500 |

48LC** 07-12 Cooling Ratings (230-v/460-v/575-v)^{a,b,c}

| UNIT SIZE | COOLING STAGES | MOTOR OPTION | NOMINAL CAPACITY (TON) | COOLING CAPACITY (MBH) | TOTAL POWER (kW) | EER | IEER | RATED INDOOR AIRFLOW (cfm) |
|-----------|----------------|--------------|------------------------|------------------------|------------------|------|------|----------------------------|
| 07 | 3 | — | 6.0 | 70.0 | 5.4 | 13.0 | 20.3 | 2250 |
| 08 | 3 | Medium | 7.5 | 89.0 | 7.0 | 12.8 | 19.0 | 2625 |
| | | High | 7.5 | 89.0 | 7.0 | 12.8 | 19.0 | 2625 |
| 12 | 3 | — | 10.0 | 116.0 | 8.9 | 13.0 | 20.3 | 3500 |

50LC** 07-12 Cooling Ratings (230-v/460-v/575-v)^{a,b,c}

| UNIT SIZE | COOLING STAGES | MOTOR OPTION | NOMINAL CAPACITY (TON) | COOLING CAPACITY (MBH) | TOTAL POWER (kW) | EER | IEER | RATED INDOOR AIRFLOW (cfm) |
|-----------|----------------|--------------|------------------------|------------------------|------------------|------|------|----------------------------|
| 07 | 3 | — | 6.0 | 70.0 | 5.3 | 13.1 | 20.5 | 2250 |
| 08 | 3 | Medium | 7.5 | 89.0 | 6.9 | 12.9 | 19.2 | 2625 |
| | | High | 7.5 | 89.0 | 7.0 | 12.8 | 19.1 | 2625 |
| 12 | 3 | — | 10.0 | 116.0 | 8.9 | 13.1 | 20.5 | 3500 |

NOTE(S):

- a. Rated in accordance with AHRI Standards 340/360.
- b. Ratings are based on:
Cooling Standard: 80°F (27°C) db, 67°F (19°C) wb indoor air temp and 95°F (35°C) db outdoor air temp.
- c. 48/50LC units comply with US Energy Policy Act. To evaluate code compliance requirements, refer to state and local codes.

LEGEND

- AHRI — Air Conditioning, Heating, and Refrigeration Institute Test Standard
- ASHRAE — American Society of Heating, Refrigeration, and Air Conditioning
- EER — Energy Efficiency Ratio



Performance ratings (cont)



48/50LC*H 07-12 Cooling Minimum – Maximum Airflow and Ambient Ratings^{a,b}

| UNIT SIZE | MAX AIRFLOW (cfm) | MIN AIRFLOW (cfm) | MAX OD AMBIENT TEMP (°F) | MIN OD AMBIENT TEMP (°F) |
|-----------|-------------------|-------------------|--------------------------|--------------------------|
| 07 | 2250 | 780 | 125 | 40 |
| 08 | 2625 | 975 | 125 | 40 |
| 12 | 3500 | 1300 | 125 | 40 |

NOTE(S):

- a. Maximum airflow is at full capacity. Minimum airflow is at minimum capacity.
- b. Min/Max airflow and min/max ambient conditions may be limited by unit configuration, entering evaporator conditions or unit mode.

48LC*H 07-12 Heat Rating – Natural Gas and Propane^{a,b,c}

| UNIT SIZE | HEAT SIZE | MIN AIRFLOW (cfm) | MAX AIRFLOW (cfm) | INPUT (mbh) | THERMAL EFFICIENCY | MAX TEMP RISE (°F) | STD TURNDOWN (NG/LP) | HIGH TURNDOWN (NG/LP) | |
|-----------|-----------|-------------------|-------------------|-------------|--------------------|--------------------|----------------------|-----------------------|-----|
| 07 | Low | 780 | 2250 | 70 | 81% | 63 | 5:1/3:1 | N/A | |
| | Medium | | | 105 | | 90 | | | |
| | High | | | 140 | | 114 | | | |
| 08 | Low | 975 | 2625 | 80 | | 58 | 5:1/3:1 | N/A | |
| | Medium | | | 120 | | 83 | | | |
| | High | | | 160 | | 104 | | | |
| 12 | Low | 1300 | 3500 | 120 | | 65 | | 5:1/3:1 | N/A |
| | Medium | | | 160 | | 83 | | | |
| | High | | | 200 | | 98 | | | |

NOTE(S):

- a. Heat ratings are for natural gas heat exchangers operated at or below 2000 ft (610 m). For information on propane or altitudes above 2000 ft (610 m), see the Application Data section of this book. High Altitude Accessory kits are required for high altitude operation.
- b. The gas heat input rating for altitudes above 2000 ft (610 m) must be derated by 4% for each 1000 ft (305 m).
- c. All gas heaters are factory configured for natural gas. An accessory LP conversion kit is available for field conversion to LP heat.

LEGEND

- NG — Natural Gas
- LP — Liquid Propane

50LC*H 07-12 Heat Rating – Electric Heat

| UNIT SIZE | HEAT SIZE | MIN AIRFLOW (cfm) | MAX AIRFLOW (cfm) | NOMINAL kW (208/230/460/575-v) | MAX TEMP RISE (°F) | CONTROLS |
|-----------|-----------|-------------------|-------------------|--------------------------------|--------------------|----------|
| 07 | Medium | 780 | 2250 | 7.8/9.6/10.6/TBD | 42/46/72 | SCR |
| | High | | | 12/14.7/23/TBD | 64/80/80 | |
| 08 | Medium | 975 | 2625 | 12/14.7/13.8/TBD | 51/48/58 | |
| | High | | | 18.8/23/30.3/TBD | 68/80/80 | |
| 12 | Medium | 1300 | 3500 | 12/14.7/13.8/TBD | 38/36/80 | |
| | High | | | 18.8/23/30.3/TBD | 60/80/80 | |

Sound Performance^{a,b,c}

| UNIT SIZE | COOLING STAGES | OUTDOOR SOUND (dB) at 60 Hz | | | | | | | | |
|-----------|----------------|-----------------------------|------|------|------|------|------|------|------|------|
| | | A-Weighted | 63 | 125 | 250 | 500 | 1000 | 2000 | 4000 | 8000 |
| 07 | 3 | 82 | 88.6 | 85.0 | 81.6 | 79.5 | 77.4 | 74.1 | 71.0 | 66.3 |
| 08 | 3 | 83 | 89.3 | 86.0 | 82.9 | 80.7 | 78.5 | 73.6 | 69.6 | 64.5 |
| 12 | 3 | 83 | 89.3 | 86.0 | 82.9 | 80.7 | 78.5 | 73.6 | 69.6 | 64.5 |

NOTE(S):

- a. Outdoor sound data is measured in accordance with AHRI standard 270.
- b. Measurements are expressed in terms of sound power. Do not compare these values to sound pressure values because sound pressure depends on specific environmental factors which normally do not match individual applications. Sound power values are independent of the environment and therefore more accurate.
- c. A-weighted sound ratings filter out very high and very low frequencies, to better approximate the response of "average" human ear. A-weighted measurements for Carrier units are taken in accordance with AHRI standard 270.

LEGEND

- dB — Decibel

48LC*H 07-12 Heating Physical Data

| NATURAL GAS HEAT | | 07 | 08 | | 12 | |
|-----------------------------------|----------------------------------|--------------------------------|--------------|---------------|--------------|---------------|
| | | STD TURNDOWN | STD TURNDOWN | HIGH TURNDOWN | STD TURNDOWN | HIGH TURNDOWN |
| SUPPLY LINE PRESSURE RANGE | | 5.0-13.0 in. wg (1244-3240 Pa) | | | | |
| LOW HEAT | No. Gas Valves | 1 | 1 | — | 1 | — |
| | No. Gas Connections | 1 | 1 | — | 1 | — |
| | Gas Connection Size (NPT) | 1/2" | 3/4" | — | 3/4" | — |
| | No. Tubes | 3 | 4 | — | 6 | — |
| | Modulation Range (%) | 20-100% | 20-100% | — | 20-100% | — |
| | Rollout Switch Open/Close (°F) | 350 | 350 | — | 350 | — |
| | Maximum Temperature Rise (°F) | 63 | 58 | — | 65 | — |
| | Condensate Connection Size (NPT) | 1/4" | 1/4" | — | 1/4" | — |
| MEDIUM HEAT | No. Gas Valves | 1 | 1 | — | 1 | 1 |
| | No. Gas Connections | 1 | 1 | — | 1 | 1 |
| | Gas Connection Size (NPT) | 1/2" | 3/4" | — | 3/4" | 3/4" |
| | No. Tubes | 5 | 6 | — | 8 | 8 |
| | Modulation Range (%) | 20-100% | 20-100% | — | 20-100% | 20-100% |
| | Rollout Switch Open/Close (°F) | 350 | 350 | — | 350 | 350 |
| | Maximum Temperature Rise (°F) | 90 | 83 | — | 83 | 83 |
| | Condensate Connection Size (NPT) | 1/4" | 1/4" | — | 1/4" | 1/4" |
| HIGH HEAT | No. Gas Valves | 1 | 1 | 2 | 1 | 2 |
| | No. Gas Connections | 1 | 1 | 2 | 1 | 2 |
| | Gas Connection Size (NPT) | 1/2" | 3/4" | 3/4" | 3/4" | 3/4" |
| | No. Tubes | 7 | 8 | 8 | 10 | 10 |
| | Modulation Range (%) | 20-100% | 20-100% | 10-100% | 20-100% | 10-100% |
| | Rollout Switch Open/Close (°F) | 350 | 350 | 350 | 350 | 350 |
| | Maximum Temperature Rise (°F) | 114 | 104 | 104 | 98 | 98 |
| | Condensate Connection Size (NPT) | 1/4" | 1/4" | 1/4" | 1/4" | 1/4" |

48LC*H 07-12 Heating Physical Data (cont)

| LIQUID PROPANE HEAT | | 07 | 08 | | 12 | |
|-----------------------------------|--------------------------------|---------------------------------|--------------|---------------|--------------|---------------|
| | | STD TURNDOWN | STD TURNDOWN | HIGH TURNDOWN | STD TURNDOWN | HIGH TURNDOWN |
| SUPPLY LINE PRESSURE RANGE | | 11.0-13.0 in. wg (2740-3240 Pa) | | | | |
| LOW HEAT | No. Gas Valves | 1 | 1 | — | 1 | — |
| | No. Gas Connections | 1 | 1 | — | 1 | — |
| | Gas Connection Size (NPT) | 1/2" | 3/4" | — | 3/4" | — |
| | No. Tubes | 3 | 4 | — | 6 | — |
| | Modulation Range (%) | 34 -100% | 34 -100% | — | 34-100% | — |
| | Rollout Switch Open/Close (°F) | 350 | 350 | — | 350 | — |
| | Maximum Temperature Rise (°F) | 63 | 58 | — | 65 | — |
| | No. Condensate Connections | 1 | 1 | — | 1 | — |
| Condensate Connection Size (NPT) | 1/4" | 1/4" | — | 1/4" | — | |
| MEDIUM HEAT | No. Gas Valves | 1 | 1 | — | 1 | 2 |
| | No. Gas Connections | 1 | 1 | — | 1 | 2 |
| | Gas Connection Size (NPT) | 1/2" | 3/4" | — | 3/4" | 3/4" |
| | No. Tubes | 5 | 6 | — | 8 | 8 |
| | Modulation Range (%) | 34 -100% | 34 -100% | — | 34-100% | 17-100% |
| | Rollout Switch Open/Close (°F) | 350 | 350 | — | 350 | 350 |
| | Maximum Temperature Rise (°F) | 90 | 83 | — | 83 | 83 |
| | No. Condensate Connections | 1 | 1 | — | 1 | 1 |
| Condensate Connection Size (NPT) | 1/4" | 1/4" | — | 1/4" | 1/4" | |
| HIGH HEAT | No. Gas Valves | 1 | 1 | 2 | 1 | 2 |
| | No. Gas Connections | 1 | 1 | 1 | 1 | 1 |
| | Gas Connection Size (NPT) | 1/2" | 3/4" | 3/4" | 3/4" | 3/4" |
| | No. Tubes | 7 | 8 | 8 | 10 | 10 |
| | Modulation Range (%) | 34 -100% | 34 -100% | 17-100% | 34-100% | 17-100% |
| | Rollout Switch Open/Close (°F) | 350 | 350 | 350 | 350 | 350 |
| | Maximum Temperature Rise (°F) | 114 | 104 | 104 | 98 | 98 |
| | No. Condensate Connections | 1 | 1 | 1 | 1 | 1 |
| Condensate Connection Size (NPT) | 1/4" | 1/4" | 1/4" | 1/4" | 1/4" | |

Physical data (cont)



48/50LC*H 07-12 Physical Data

| UNIT SIZE | 07 | 08 | 12 |
|---|--|--|--|
| Refrigeration System | | | |
| No. Circuits / No. Comp. / Type | 1/ 2/Scroll | 1/ 2/Scroll | 1/ 2/Scroll |
| R-410A charge (lb-oz) | 25-0 | 30-0 | 35-0 |
| Oil Charge (oz) | 25/42 | 42/42 | 42/42 |
| Metering Device | TXV | TXV | TXV |
| High-press. Trip / Reset (psig) | 630/505 | 630/505 | 630/505 |
| Low-press. Trip / Reset (psig) | — | — | 54/117 |
| Loss of charge Trip/Reset (psig) | 27/44 | 27/44 | — |
| Evaporator Coil | | | |
| Material (Tube/Fin) | Cu / Al | Cu / Al | Cu / Al |
| Coil Type | 5/16 in. RTPF | 5/16 in. RTPF | 5/16 in. RTPF |
| Coil Length (in.) | 40 | 52.5 | 52.5 |
| Coil Height (in.) | 40 | 48 | 48 |
| Rows / FPI | 4/15 | 4/15 | 4/15 |
| Total Face Area (ft ²) | 11.1 | 17.5 | 17.5 |
| Condensate Drain Conn. Size | 3/4 in. | 3/4 in. | 3/4 in. |
| Hot Gas Reheat (HGRH) Coil | | | |
| Material | Cu/Al | Cu/Al | Cu/Al |
| Coil Type | 5/16 in. RTPF | 5/16 in. RTPF | 5/16 in. RTPF |
| Coil Length (in.) | 38 | 49.5 | 49.5 |
| Coil Height (in.) | 32 | 40 | 40 |
| Rows / FPI | 2/18 | 1/18 | 1/18 |
| Total Face Area (ft ²) | 8.4 | 13.8 | 13.8 |
| Evap. Fan and Motor | | | |
| Medium Static | | | |
| Motor Qty / Drive Type | 1/Direct | 1/Direct | 1/Direct |
| Max BHP | 2.4 | 2.4 | 2.4 |
| RPM Range | 250-2000 | 250-2000 | 250-2000 |
| Fan Qty / Type | 1/Vane Axial | 1/Vane Axial | 1/Vane Axial |
| Fan Diameter (ft) | 22 | 22 | 22 |
| High Static | | | |
| Motor Qty / Drive Type | 1/Direct | 1/Direct | 1/Direct |
| Max BHP | 5 | 5 | 5 |
| RPM Range | 250-2200 | 250-2200 | 250-2200 |
| Fan Qty / Type | 1/Direct | 1/Direct | 1/Direct |
| Fan Diameter (ft) | 22 | 22 | 22 |
| Cond. Coil 1 | | | |
| Material | Cu/Al | Cu/Al | Cu/Al |
| Coil Type | 5/16 in. RTPF | 5/16 in. RTPF | 5/16 in. RTPF |
| Coil Length (in.) | 82 | 100 | 64 |
| Coil Height (in.) | 44 | 52 | 52 |
| Rows / FPI | 2/18 | 2/18 | 2/18 |
| Total Face Area (ft ²) | 25.1 | 36.1 | 23.1 |
| Cond. Coil 2 | | | |
| Material | — | — | Cu/Al |
| Coil Type | — | — | 5/16 in. RTPF |
| Coil Length (in.) | — | — | 64 |
| Coil Height (in.) | — | — | 52 |
| Rows / FPI | — | — | 2/18 |
| Total Face Area (ft ²) | — | — | 23.1 |
| Cond. Fan/ Motor | | | |
| Qty / Motor Drive Type | 2/Direct | 3/Direct | 3/Direct |
| Motor HP / RPM | 1/3 / 1000 | 1/3 / 1000 | 1/3 / 1000 |
| Fan Diameter (in.) | 22 | 22 | 22 |
| Filters | | | |
| Standard 2 in. RA Filter No. / Size (in.) | 4/ 20 x 20 x 2 | 6/ 18 x 24 x 2 | 6 / 18 x 24 x 2 |
| Optional 4 in. RA Filter No. / Size (in.) | 4/ 16 x 20 x 4 | 4/ 16 x 20 x 4 2/ 20 x 20 x 4 | 4/ 16 x 20 x 4 2/ 20 x 20 x 4 |
| OA Inlet Screen No. / Size (in.) | V 2 / 24 x 27 x 1 H 1 / 30 x 39 x 1 | V 2 / 24 x 27 x 1 H 1 / 30 x 39 x 1 | V 2 / 24 x 27 x 1 H 1 / 30 x 39 x 2 |

48/50LC*H 07-12 Factory-installed Options and Field-installed Accessories

| CATEGORY | ITEM | FACTORY-INSTALLED OPTION | FIELD-INSTALLED ACCESSORY |
|---------------------------------------|---|--------------------------|---------------------------|
| NATURAL GAS HEAT (48 SERIES) | Low, medium, or high modulating heat, standard turndown (5:1) | X | |
| | Medium, or high modulating heat, standard turndown (5:1) | X | |
| | High elevation kit, up to 7000 ft | | X |
| | Propane conversion kit (3:1 or 6:1 turndown) | | X |
| ELECTRIC HEAT (50 SERIES) | Medium or high capacity electric heat with SCR control | X | |
| SENSOR OPTIONS | Return and supply smoke detectors | X | X |
| | Return air CO ₂ sensor | X | X |
| | Space temperature or relative humidity sensors | | X |
| | Two-stage heating and cooling thermostats | | X |
| INDOOR FAN OPTIONS | High static supply fan motor (5 HP) | X | |
| | Duct static pressure control with pressure transducer | X | |
| | Zone static pressure control with pressure transducer | X | |
| | Horizontal supply conversion kit | | Size 08-12 |
| | Return air blank-off panel | | X |
| COIL OPTIONS | Pre-coated or e-coated condenser coil | X | |
| | E-coated evaporator and HGRH coil | X | |
| | Condenser coil hail guard | X | X |
| OUTDOOR AIR AND RELIEF OPTIONS | Ultra low leak economizer with barometric relief | X | X |
| | Modulating power exhaust | | X |
| SERVICE AND IAQ OPTIONS | Powered and non-powered convenience outlet | X | |
| | 4 in. pre-filter rack with MERV 8 or 13 filters | X | X |
| ELECTRICAL OPTION | Non-fused disconnect ^a | X | |
| | HACR breaker ^{a,b} | X | |
| | Thru-the-base power and gas connection | X | X |
| CONSTRUCTION AND PACKAGING | Double wall construction with galvanized liner (except ERV section) | X | |

NOTE(S):

- a. When selecting a factory-installed HACR breaker or non-fused direct disconnect, note they are sized for the unit or ordered from the factory and do not support single point power accessories (power exhaust).
- b. On 575-v applications, HACR breaker can only be used with WYE power distribution systems. Using on Delta power distributions systems is prohibited.

Factory-installed options

Natural gas heat (48 series)

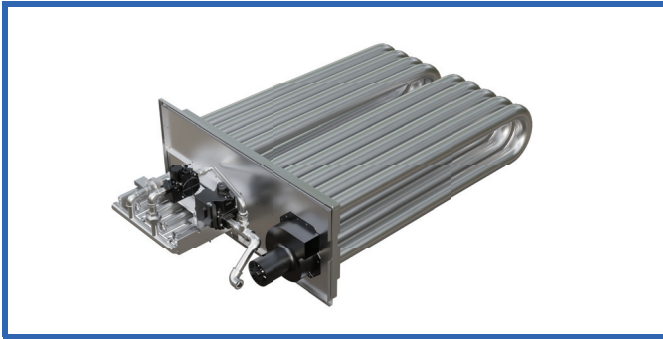

The 48LC*H unit features a factory-installed, induced draft style natural gas heat system that has been specifically selected for high outdoor air applications. All gas heat exchangers are made from 409 grade stainless steel for high temperature rise capability. Heat exchangers are backed by a 5-year parts warranty.

48LC*H units are selectable with low, medium, or high capacity heat. Standard turndown heater option provides 5:1 turndown modulating control for low load heating operation or supply air tempering capability.

For applications requiring higher turndown, the high turndown heat option provides 10:1 turndown modulating control for select units and heat sizes. Increasing the heater turndown can provide a lower minimum temperature rise when compared, which may allow for a wider low operating range and heating fuel savings. Higher turndown heaters are more likely to experience condensate generation at very low loads and may require condensate traps with freeze protection. A condensate drain connection is included for low ambient, high turndown applications where condensate may form.

Electric heat (50 series)

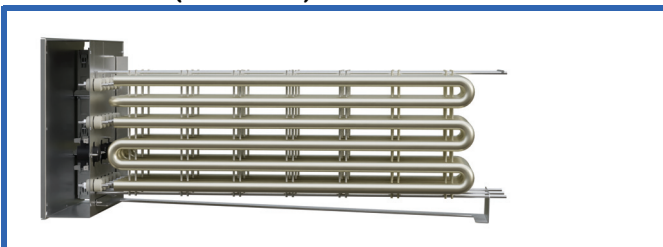

50LC*H units are available with a factory-installed electric heater, intended for mild climate applications. Electric heaters are available in medium and high capacity, with the capacity depending on the unit size and voltage. All electric heaters include silicon rectifier control (SCR) for fully modulating operation for low load conditions. The electric heat is fed by the main unit terminal block (single point power).

Smoke detectors

Units are available with a factory-installed return air, supply air, or return air and supply air smoke detector. The smoke detector interfaces with the Carrier SmartVu control to shutdown the unit when smoke is detected.

Duct pressure control

Units can be equipped with a factory-installed supply duct static pressure sensor for duct static pressure control of the supply fan. SmartVu will read the duct static pressure

sensor and will modulate the supply fan speed to maintain the duct static pressure at the adjustable duct static pressure setpoint.

Supply fan duct static pressure control is commonly used for applications with air terminal units, or for constant cfm operation to account for filter loading.

Zone pressure control

Units being applied in 100% outdoor air applications can be equipped with a factory-installed building static pressure sensor for building pressure control of the supply fan. With the outdoor air damper fully open, SmartVu will read the duct static pressure sensor and will modulate the supply fan speed, which will modulate the amount of outdoor air introduced to the zone, to maintain the zone pressure at the zone pressure setpoint.

Supply fan zone static pressure control is commonly used for make-up air applications with modulated exhaust. Zone pressure supply fan control cannot be combined with SmartVu building static pressure control of the exhaust fan.

Pre-coated condenser coils

A durable epoxy-phenolic coating to provide condenser coil protection in mildly corrosive environments. The coating minimizes galvanic action between dissimilar metals. Coating is applied to the aluminum fin stock prior to the fin stamping process to create an inert barrier between the aluminum fin and copper tube.

E-coated indoor and outdoor coils

A flexible epoxy polymer coating uniformly applied to all coil surfaces to provide full coil protection in mildly corrosive environments. Coating process shall ensure complete coil encapsulation of tubes, fins and headers.

Coating can be applied to condenser coil only or condenser coil and the indoor coils (evaporator and HGRH). When applying equipment with high outdoor air applications in mildly corrosive environments, coating the condenser and indoor coils is recommended. Field provided coating may be required in coastal or near-coastal environments.

Louvered hail guard

A sleek, louvered panel protects the condenser coil from hail damage, foreign objects, and incidental contact. The hail guard is made from galvanized steel and includes an exterior coating that matches the unit cabinet.

Ultra low leak economizer with barometric relief



A factory-installed economizer with barometric relief is available for units with vertical return. The economizer assembly includes an outdoor air hood with hood screen, a

gear driven, ultra-low leak outdoor and return air damper with electronic actuator, and a barometric relief damper.

The economizer can be used for free cooling, indoor air quality (IAQ) and ventilation control. The Carrier SmartVu™ control provides economizer operation and facilitates fault detection and diagnostic (FDD) capability when used with the factory-installed economizer.

The Carrier SmartVu control can be configured to operate the economizer for free cooling based on outdoor air dry bulb or enthalpy, outdoor air and return air dry bulb or enthalpy differential, and outdoor air dewpoint limit, using the factory-installed OAT, OARH, RAT, and RARH sensors. IAQ operation can be accomplished using a factory-installed or field-installed return air CO₂ sensor, or field-installed space CO₂ sensor.

A barometric relief system is provided to allow building pressure relief during high outdoor air operation in applications with low return duct static pressure drops, such as single story buildings. The barometric relief system includes a gravity operated damper that is closed during normal operation and opens when the building pressure is high enough to force the damper open.

Return air CO₂ sensor

A factory-installed return air CO₂ sensor is available for applications requiring indoor air quality (IAQ) control for demand control ventilation (DVC) to decrease ventilation air for energy savings when the space isn't fully occupied. The IAQ sensor is connected to the Carrier SmartVu control and can be used with multiple IAQ functions within the control program.

4 in. filter rack

A factory-installed 4 in. filter track to allow the use of a higher rating or lower pressure drop filters. The 4 in. filter rack option is available with factory-installed 4 in. MERV 8 or 4 in. MERV 13 pleated filters.

Double wall construction

Units are available with double wall construction, which includes a galvanized steel interior liner on the air touching portions of the unit cabinet over the standard 1/2 in. R4 insulation. The double wall construction option provides wipe-down capability for the unit interior.

Thru-the-base connection

Thru-the-base connections are available as a factory-installed option on size 07-12 units. The thru-the-base connection provides a coupling at the bottom of the unit to allow power and control wiring and gas piping to enter the unit through the base pan. For roof curb mounted applications, the thru-the-base connection reduces the need for a separate, weather-tight, roof penetration power, control, and gas piping.

HACR breaker

The heating, air-conditioning, and refrigeration (HACR) breaker is a manual reset device that provides overload and short circuit protection for the unit. The HACR breaker is factory sized per the unit MOCP and is factory wired and installed. An access cover is provided to protect the breaker from the environment.

NOTE: The HACR breaker is sized based on the base unit MOCP and does not provide provision for single point accessories, such as power exhaust fans. For 575-v

applications, the HACR breaker can only be used in wye-power systems.

Non-fused disconnect

This OSHA-compliant, factory-installed, safety switch allows a service technician to locally disconnect and secure power to the unit with the included lock point for lockout/tagout.

NOTE: The non-fused disconnect is sized based on the base unit MOCP and does not provide provision for single point accessories, such as power exhaust fans.

Powered convenience outlet

Includes a factory-installed 15A, 115-v GFCI covered outlet that is powered by a 115-v transformer connected to the load side of the unit terminal block.

Un-powered convenience outlet

Includes a factory-installed 15A, 115-v GFCI covered outlet that is powered by a 115-v transformer for field power connection.

Field-installed accessories

Economizer

Field-installed low leak and ultra low leak EconoMi\$er®2 system is available for units with vertical return or horizontal return. The economizer operation is controlled by the Carrier SmartVu™ controller.

High elevation kit

A high elevation conversion kit is available for natural gas heat applications with elevations from 2000-7000 ft.

Propane heat conversion kit

For applications requiring propane heat, a field-installed conversion kit is available to convert a natural gas furnace to propane heat. The conversion kit includes new orifices for elevations up to 7000 ft. and a new inducer fan plate.

NOTE: When converting to propane, the standard 5:1 turndown heaters with natural gas will be increased to 3:1 turndown for propane. The 10:1 turndown heater in natural gas becomes 6:1 turndown with propane.

Modulating power exhaust

A field-installed, modulating power exhaust is available for units with an economizer to allow for space pressure control. The modulating power exhaust fan includes a building pressure transducer. The power exhaust fan is modulated by the Carrier SmartVu control based on the building static pressure reading.

Thru-the-base connections

Thru-the-base connections are available as a field-installed kit for unit size 07-12.

Horizontal supply/return conversion kit

A field-installed vertical supply duct cover is available for use when converting unit sizes 08 and 12 from vertical supply/return to horizontal supply/return.

Return air blank-off

A return air blank-off panel is available for applications operating at 100% outdoor air without return, barometric relief, or power exhaust. The blank-off panel is constructed of galvanized steel with 1/2 in. foil face insulation and is available with a galvanized interior liner for double wall units.

Thermostats

Carrier offers multiple two-stage cooling/two-stage heating thermostats for use with the Carrier SmartVu control.

Sensors

Multiple sensors are available for field installation, including space temperature, space relative humidity, and space or return air CO₂ sensors. The Carrier SmartVu controls are not compatible with Carrier ZS communicating sensors.

Control interfaces

The Carrier SmartVu control settings can be accessed from a PC web browser via a direct connection to the controller Ethernet port.

The SmartVu controls are also plug-and-play compatible with the Carrier i-Vu® 8.0+ web-based operator interfaces via CCN or BACnet communication bus.

The SmartVu controls are not compatible with Equipment and System Touch displays, Field Assistant, BACView, Touch Pilot™, or Navigator interfaces.

Smoke detectors

Field-installed supply and return smoke detectors are available. The smoke detectors interface with the Carrier SmartVu control.

Louvered hail guards

Field-installed louvered hail guards are available for units without factory-installed hail guards for condenser coil protection.

Filters

A wide array of accessory filters are available for upgrade of factory filters or for customer replacements for factory filters. An accessory kit to convert the standard 2 in. filter rack to a 4 in. filter rack is also available.

Options and accessories (cont)



Option and Accessory Weights

| OPTION/ACCESSORY | WEIGHTS IN LB | | |
|--|---------------|-----------|-----------|
| | 48LC*H 07 | 48LC*H 08 | 48LC*H 12 |
| Medium Modulating Electric Heat | 26 | 26 | 26 |
| High Modulating Electric Heat | 30 | 30 | 30 |
| Medium Gas Heat | 25 | 27 | 27 |
| High Gas Heat | 40 | 54 | 54 |
| Return Smoke Detector | 5 | 5 | 5 |
| Supply Smoke Detector | 5 | 5 | 5 |
| CO ₂ Sensor | 5 | 5 | 5 |
| Duct Pressure Transducer | 5 | 5 | 5 |
| Building Pressure Transducer | 5 | 5 | 5 |
| High Static Motor | 30 | 30 | 30 |
| Hail Guard | 34 | 45 | 45 |
| Pre-coat Al/Cu Cond Coil | 0 | 0 | 0 |
| E-coat Al/Cu Cond and Al/Cu Evap Coils | 0 | 0 | 0 |
| E-coat Al/Cu Cond and E-coat Al/Cu Evap Coils | 0 | 0 | 0 |
| Enthalpy Ultra Low Leak Economizer w/Baro Relief | 74 | 103 | 103 |
| Unpowered Convenience Outlet | 5 | 5 | 5 |
| Powered Convenience Outlet | 35 | 35 | 35 |
| Hinged Panels | 5 | 5 | 5 |
| HACR Breaker | 10 | 10 | 10 |
| Non-Fused Disconnect | 15 | 15 | 15 |

48LC*07 Base Unit Dimensions

- NOTES:**
1. DIMENSIONS ARE IN INCHES. DIMENSIONS IN () ARE IN MILLIMETERS.
 2. CENTER OF GRAVITY
 3. DIRECTION OF AIR FLOW
 4. ALL VIEW DRAWN USING 3RD ANGLE



THIS DOCUMENT IS THE PROPERTY OF CARRIER CORPORATION. SUBMISSION OF THESE DRAWINGS OR DOCUMENTS DOES NOT CONSTITUTE PART PERFORMANCE OR ACCEPTANCE OF CONTRACT.

CONNECTION SIZES

| | | |
|---|-------------|--|
| A | 1 3/8" (35) | DIA FIELD POWER SUPPLY HOLE |
| B | 2 1/2" (64) | DIA POWER SUPPLY KNOCKOUT |
| C | 1 3/4" (51) | DIA GAGE ACCESS PLUG |
| D | 7/8" (22) | DIA FIELD CONTROL WIRING HOLE |
| E | 3/4" (19) | CONDENSATE DRAIN |
| F | 3/4" - 1/4" | WPT CONDENSATE DRAIN |
| G | 2" (51) | DIA POWER SUPPLY KNOCK-OUT |
| H | 1/4" | WPT GAS HEATER CONDENSATE DRAIN HIGH ON ONLY |

THRU-THE-BASE CHART (FIELD INST)

THESE HOLES REQUIRED FOR USE WITH ACCY KITS:
 CRB1MWR002A01: GAS THRU CURB
 CRB1MWR004A01: GAS THRU BASEPAN

| | THREADED CONDUIT SIZE | WIRE USE | REQ'D HOLE SIZE (MAX.) |
|-----|---------------------------------------|----------------------|------------------------|
| W | 1/2" | ACC. | 7/8" (22.2) |
| X | 1/2" | 2AV | 7/8" (22.2) |
| Y | 1 1/4" (002.004) | POWER | 1 3/4" (44.4) |
| Z * | (004) 3/4" FPT | GAS | 1 3/4" (44.4) |
| * | (002) PROVIDES 3/4" FLANGE & FITTING. | HOLE SIZE: 2" (50.8) | |

THRU-THE-BASE CHART (FOP)

FOR "THRU-THE-BASEPAN" FACTORY OPTION,
 FITTINGS FOR ONLY X, Y, & Z ARE PROVIDED. **
 FOR BELOW LISTED MODELS, A FIELD SUPPLIED 1/2" ADAPTER IS REQUIRED BETWEEN BASE PAN FITTING AND GAS VALVE:
 ** 48LC01

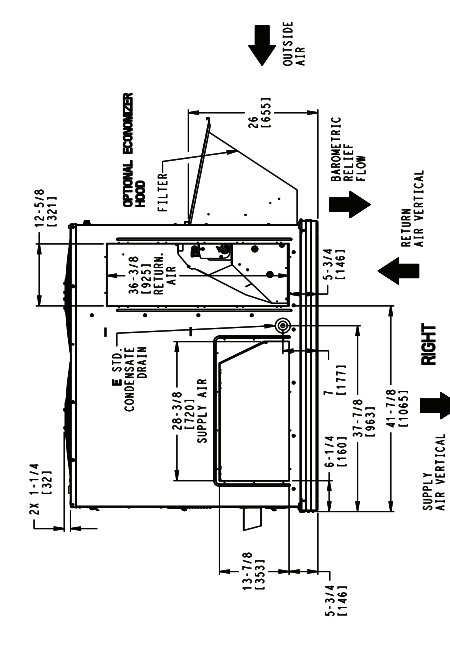
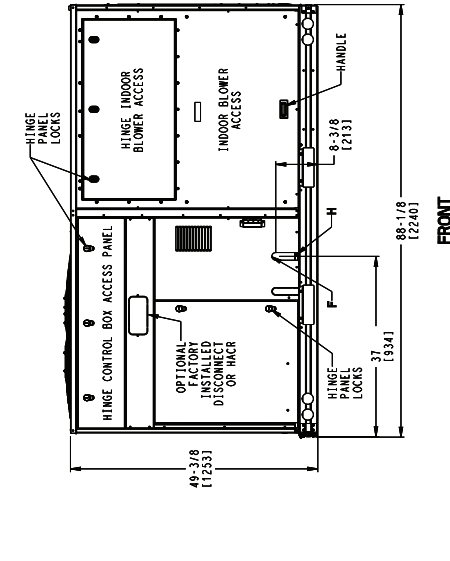
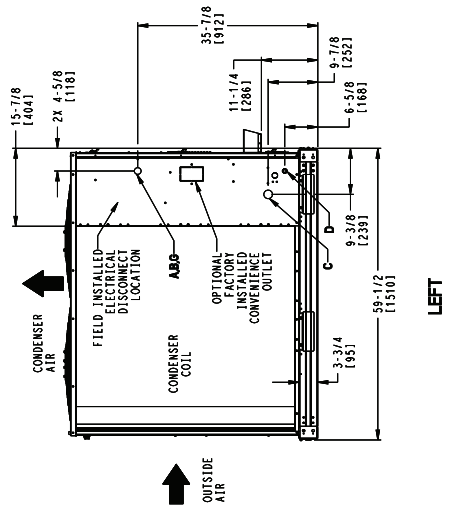
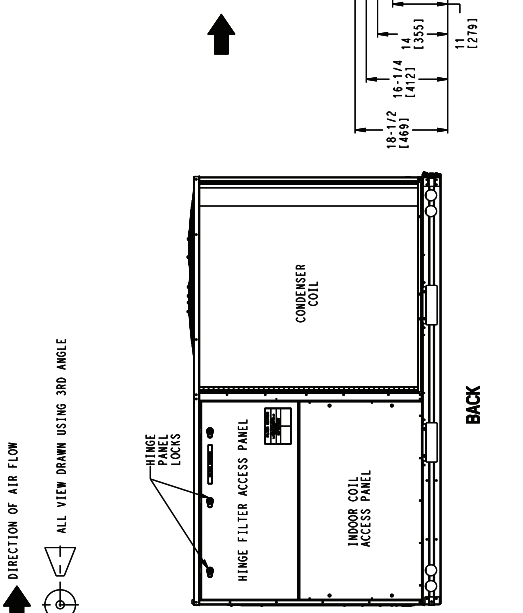
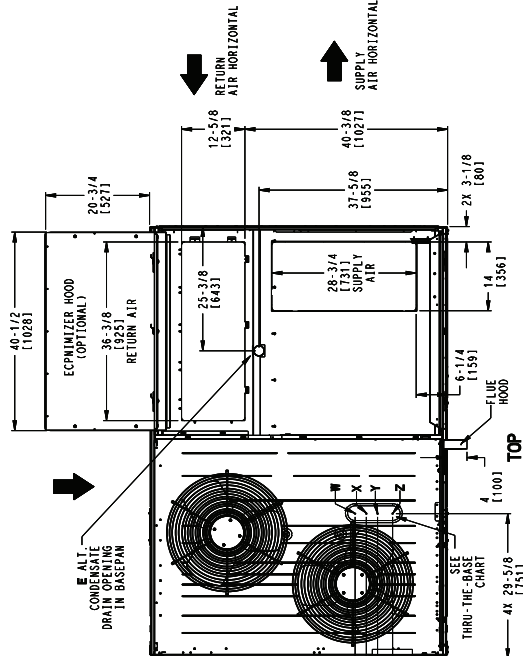

| | | | | |
|--------------------|--------|--------|------------|------------|
| IIC CLASSIFICATION | SHEET | DATE | SUPERCEDES | REV |
| U.S. ECCN:MSR | 1 OF 3 | 4/5/22 | 4/5/22 | 48LC001019 |

48LC*07 Base Unit Dimensions (cont)

Carrier
 THIS DOCUMENT IS THE PROPERTY OF CARRIER CORPORATION. PERMISSION OF THESE DRAWINGS OR SPECIFICATIONS AND IS DELIVERED UPON THE EXPRESS CONDITION THAT THE USER SHALL NOT REPRODUCE OR TRANSMIT IN ANY MANNER OR FOR ANY PURPOSE WITHOUT CARRIER CORPORATION'S WRITTEN CONSENT.

| UNIT | INSULATION | OUTDOOR COIL TYPE | STD. UNIT WEIGHT *** | | CORNER WEIGHT (A) | | CORNER WEIGHT (B) | | CORNER WEIGHT (C) | | CORNER WEIGHT (D) | | C.G. | | |
|----------|-------------|-------------------|----------------------|-----|-------------------|-----|-------------------|-----|-------------------|-----|-------------------|-----|--------|--------|--------|
| | | | LBS. | KG. | LBS. | KG. | LBS. | KG. | LBS. | KG. | LBS. | KG. | X | Y | Z |
| 48LC*H07 | FOIL FACE | RTPF | 1059 | 481 | 187 | 150 | 68 | 235 | 107 | 262 | 119 | 42 | 24 1/2 | 20 3/4 | 20 3/4 |
| 48LC*H07 | DOUBLE WALL | RTPF | 1203 | 546 | 204 | 182 | 83 | 286 | 130 | 286 | 130 | 45 | 24 1/2 | 20 3/4 | 20 3/4 |

*** STANDARD UNIT WEIGHT IS WITH LOW GAS HEAT AND WITHOUT PACKAGING. FOR OTHER OPTIONS AND ACCESSORIES, REFER TO THE PRODUCT DATA CATALOG.

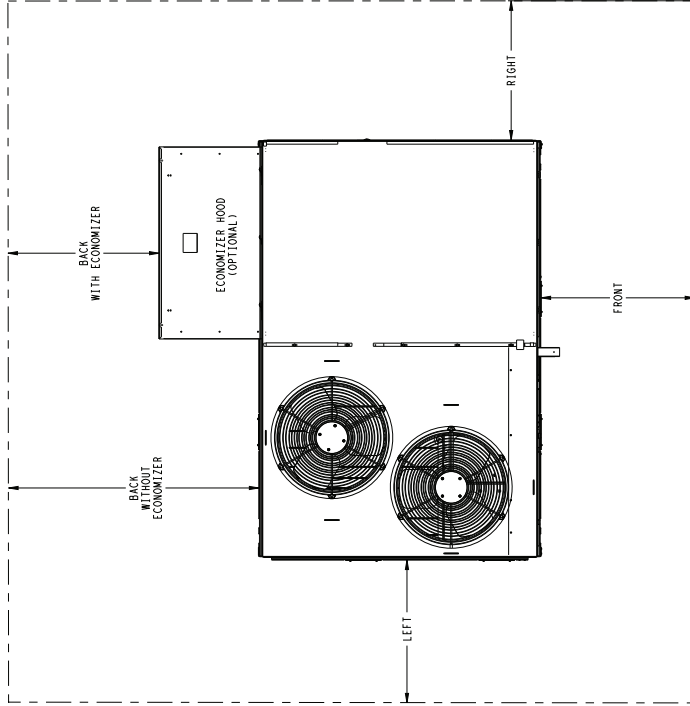
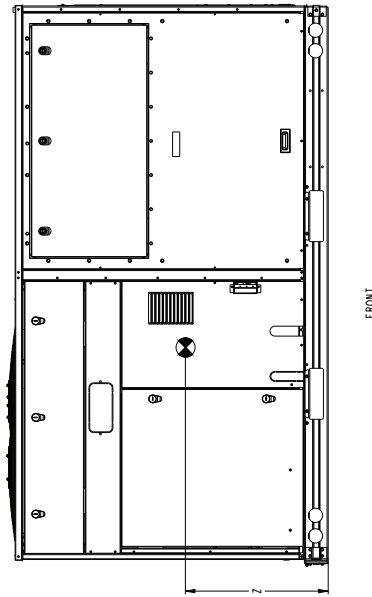
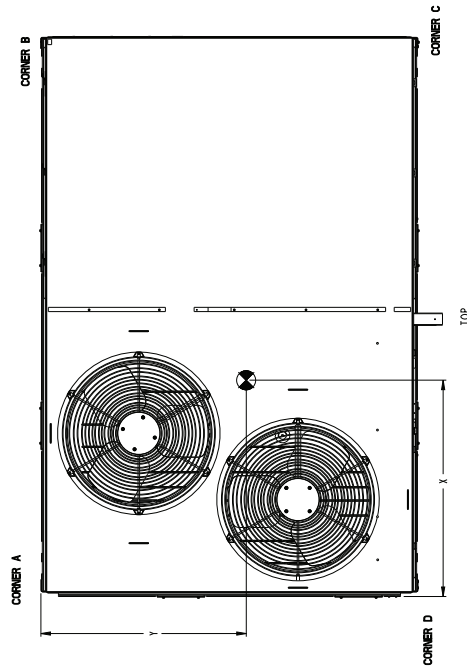

| SURFACE | CLEARANCE | |
|---------------|---------------------------------|------------------------------------|
| | SERVICE WITH CONDUCTIVE BARRIER | SERVICE WITH NONCONDUCTIVE BARRIER |
| FRONT | 48 [1219mm] | 36 [914mm] |
| LEFT | 48 [1219mm] | 42 [1067mm] |
| BACK W/O ECON | 48 [1219mm] | 42 [1067mm] |
| BACK W/ECON | 36 [914mm] | 36 [914mm] |
| RIGHT | 36 [914mm] | 36 [914mm] |
| TOP | 72 [1829mm] | 72 [1829mm] |

| ITC CLASSIFICATION | SHEET | DATE | SUPERCEDES | REV |
|--|--------|---------|------------|------------|
| U.S. - ECCN:MSR | 2 OF 3 | 4/15/22 | 4/15/22 | - |
| 48LC 07 SINGLE ZONE ELECTRICAL COOLING WITH GAS HEAT | | | | 48LC001019 |

NOTE:
 1. FOR ALL MINIMUM CLEARANCES LOCAL CODES OR JURISDICTIONS MAY PREVAIL.

Dimensions (cont)



48LC*07 Base Unit Dimensions (cont)

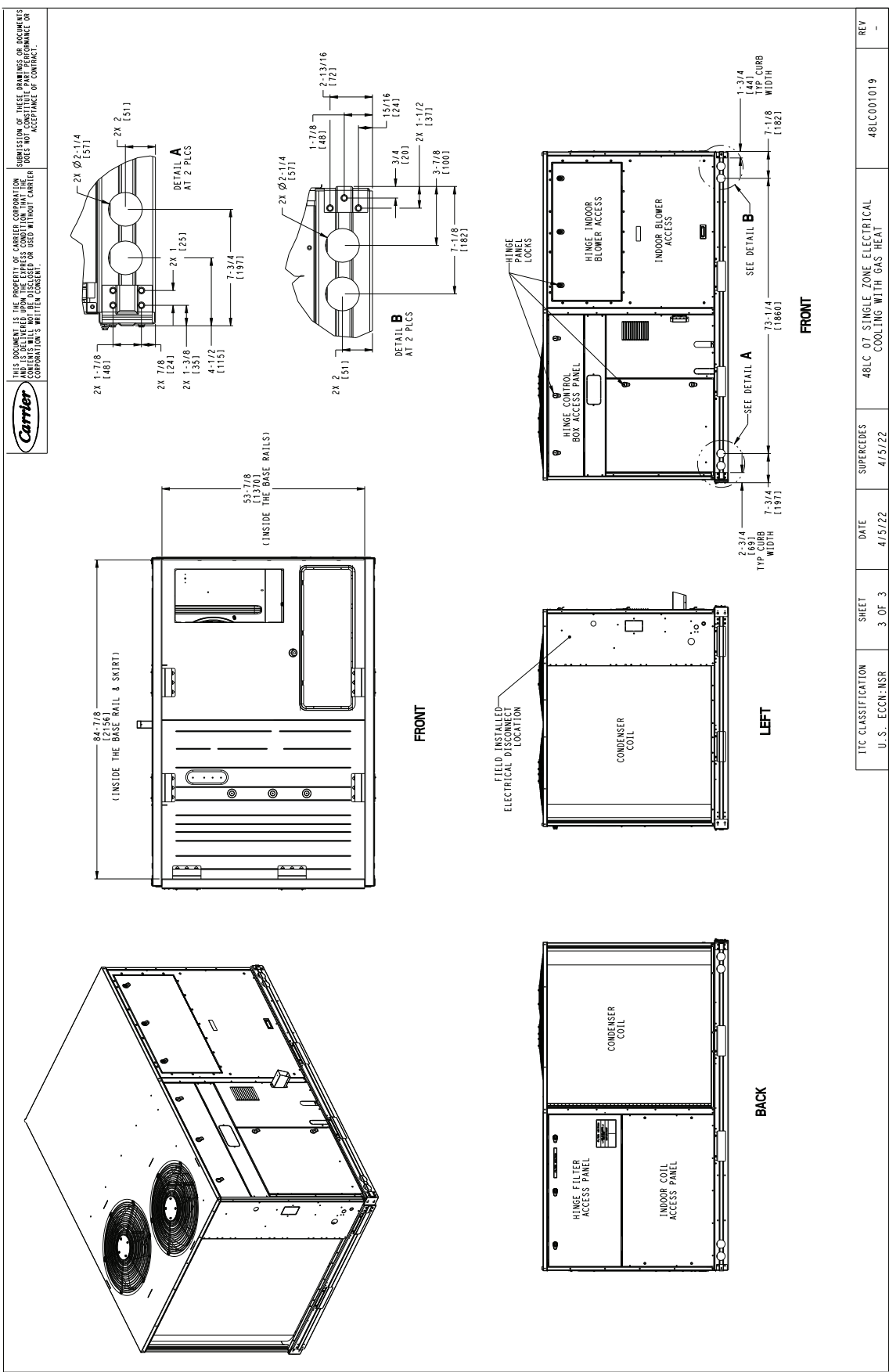

| TIC CLASSIFICATION | SHEET | DATE | SUPERCEDES | REV |
|--|--------|--------|------------|------------|
| U. S. _ECCN:_NSR | 3 OF 3 | 4/5/22 | 4/5/22 | - |
| 48LC 07 SINGLE ZONE ELECTRICAL COOLING WITH GAS HEAT | | | | 48LC001019 |

48LC*08 Base Unit Dimensions

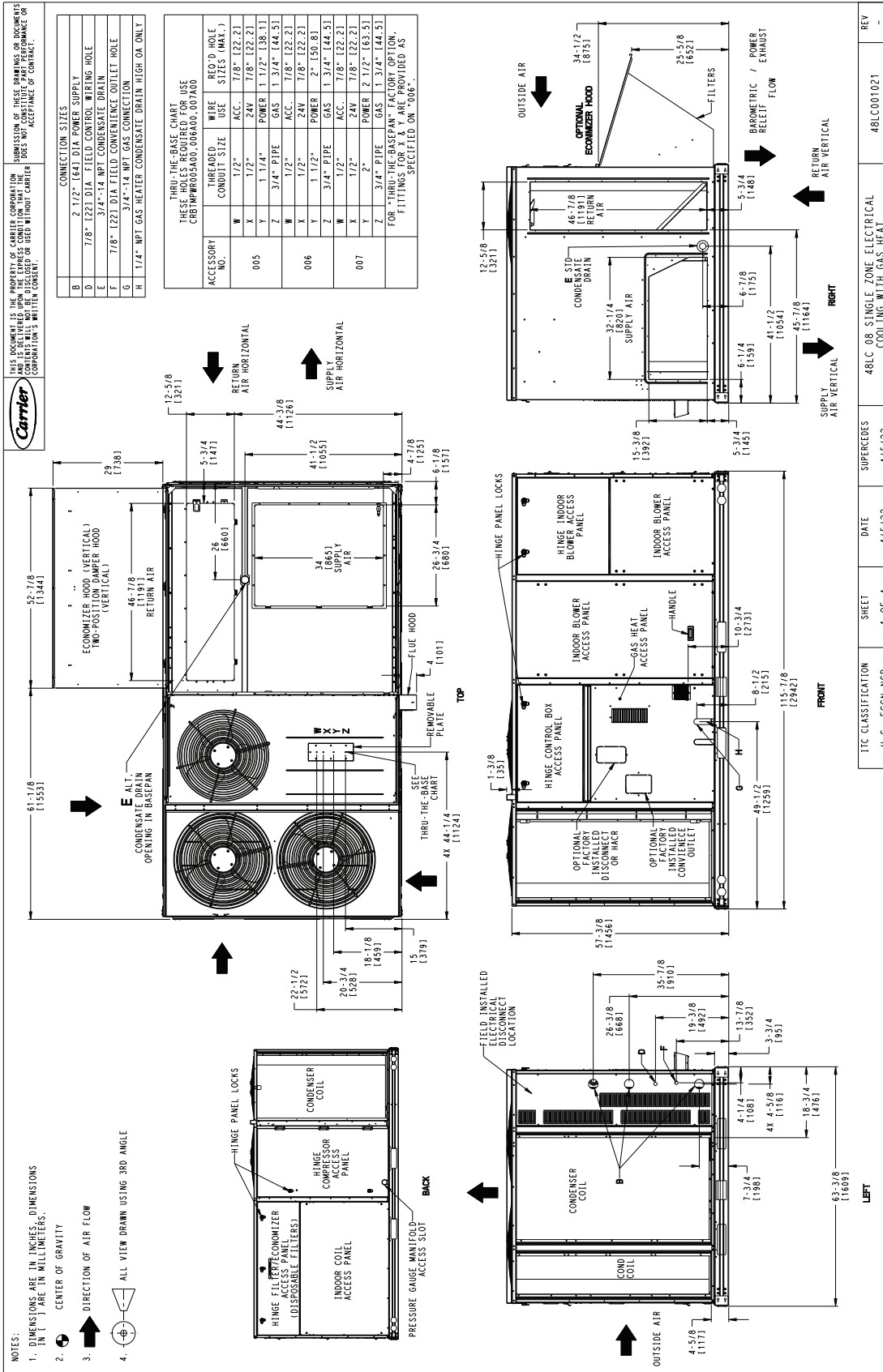

THIS DOCUMENT IS THE PROPERTY OF CARRIER CORPORATION AND IS DELIVERED UPON THE EXPRESS CONDITION THAT THE RECIPIENT WILL NOT REPRODUCE OR TRANSMIT IT IN ANY FORM OR BY ANY MEANS, ELECTRONIC OR MECHANICAL, INCLUDING PHOTOCOPYING, RECORDING, OR BY ANY INFORMATION STORAGE AND RETRIEVAL SYSTEM, WITHOUT THE WRITTEN CONSENT OF CARRIER CORPORATION.

| TIC CLASSIFICATION | SHEET | DATE | SUPERCEDES | REV |
|--|--------|---------|------------|------------|
| U.S. ECCN:NSR | 1 OF 4 | 4/15/22 | 4/15/22 | - |
| 48LC_08_SINGLE_ZONE_ELECTRICAL_COOLING_WITH_GAS_HEAT | | | | 48LC001021 |

48LC*08 Base Unit Dimensions (cont)

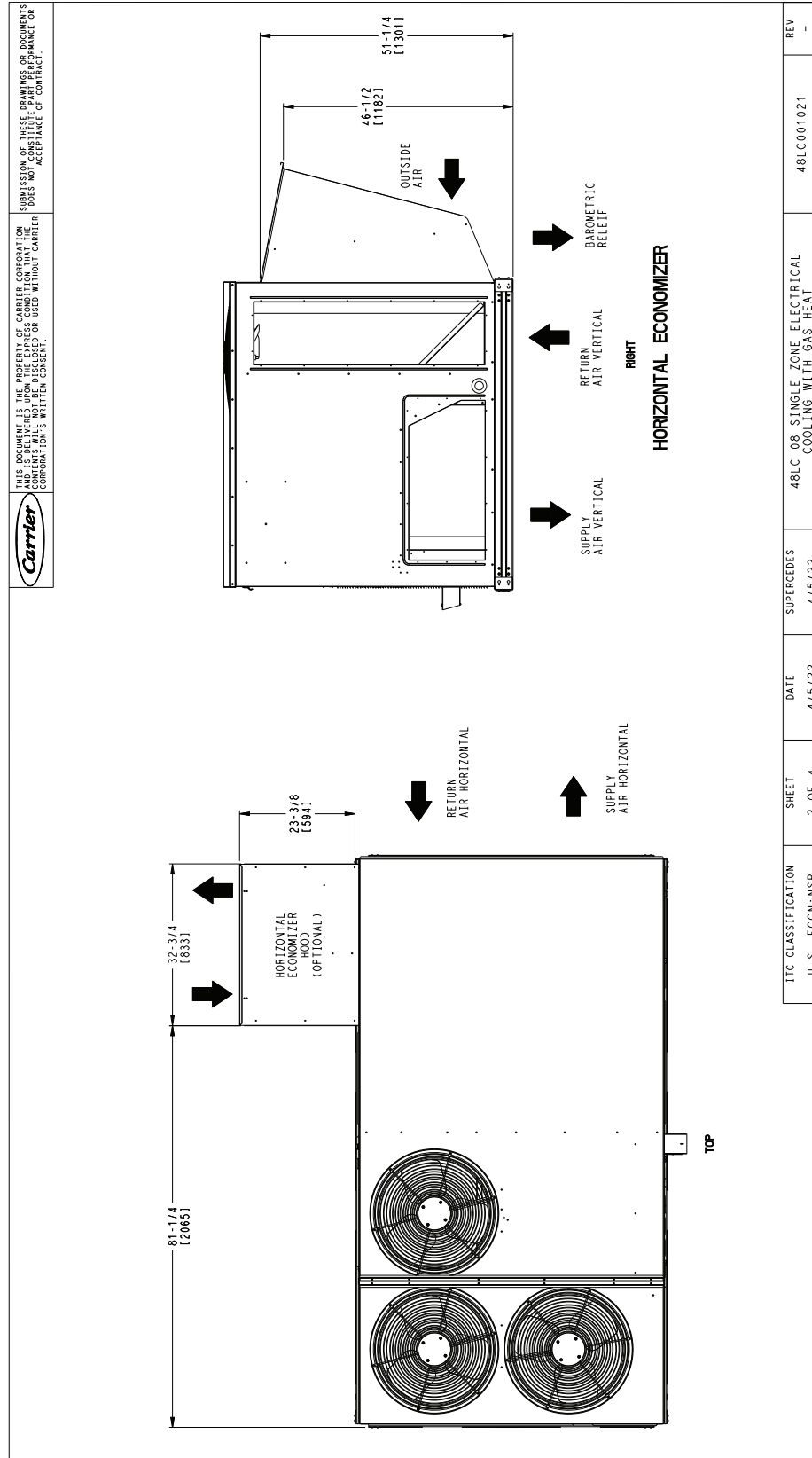

Carrier

THIS DOCUMENT IS THE PROPERTY OF CARRIER CORPORATION AND IS DELIVERED UPON THE EXPRESS CONDITION THAT THE CONTENTS WILL NOT BE DISCLOSED OR USED WITHOUT CARRIER'S WRITTEN CONSENT.

SUBMISSION OF THESE DRAWINGS OR DOCUMENTS DOES NOT CONSTITUTE AN OFFER OF WARRANTY OR ACCEPTANCE OF CONTRACT.

| | | | | | |
|--------------------------------------|-----------------|----------------|----------------------|--|----------|
| ITC CLASSIFICATION U.S. ECCN: NSR | SHEET 2 OF 4 | DATE 4/5/22 | SUPERCEDES 4/5/22 | 48LC_08_SINGLE_ZONE_ELECTRICAL_COOLING_WITH_GAS_HEAT | REV - |
|--------------------------------------|-----------------|----------------|----------------------|--|----------|

48LC*08 Base Unit Dimensions (cont)

Carrier
 THIS DOCUMENT IS THE PROPERTY OF CARRIER CORPORATION. REPRODUCTION OF THESE DRAWINGS OR SPECIFICATIONS AND IS DELIVERED UNDER THE EXPRESS CONDITION THAT THE INFORMATION CONTAINED HEREIN IS NOT TO BE USED WITHOUT CARRIER CORPORATION'S WRITTEN CONSENT.

| UNIT | INSULATION | OUTDOOR COIL TYPE | STD. UNIT WEIGHT *** | | CORNER WEIGHT (A) | | CORNER WEIGHT (B) | | CORNER WEIGHT (C) | | CORNER WEIGHT (D) | | C.G. | | | | | |
|----------|-------------|-------------------|----------------------|-----|-------------------|-----|-------------------|-----|-------------------|-----|-------------------|-----|------|-----|----|-----|----|-----|
| | | | LBS. | KG. | LBS. | KG. | LBS. | KG. | LBS. | KG. | LBS. | KG. | X | Y | Z | | | |
| 48LC*H08 | FOLL FACE | R1PF | 1516 | 688 | 393 | 178 | 365 | 166 | 389 | 177 | 369 | 167 | 57 | 172 | 30 | 1/2 | 20 | 5/8 |
| 48LC*H08 | DOUBLE WALL | R1PF | 1707 | 774 | 419 | 190 | 433 | 196 | 461 | 209 | 394 | 179 | 60 | 1/2 | 30 | 1/2 | 20 | 5/8 |

*** STANDARD UNIT WEIGHT IS WITH LOW GAS HEAT AND WITHOUT PACKAGING. FOR OTHER OPTIONS AND ACCESSORIES, REFER TO THE PRODUCT DATA CATALOG.

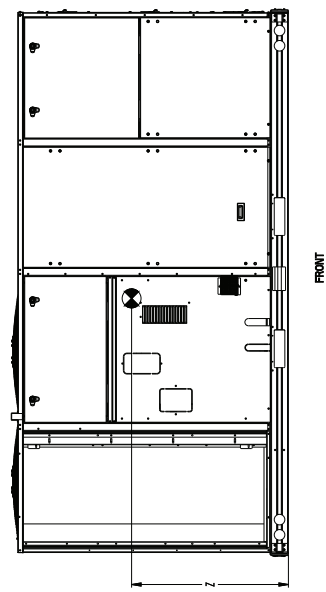
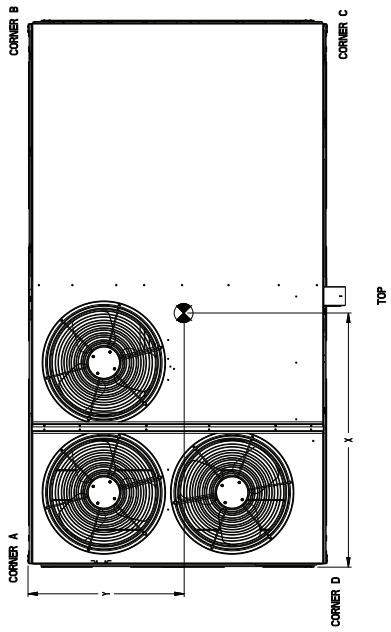
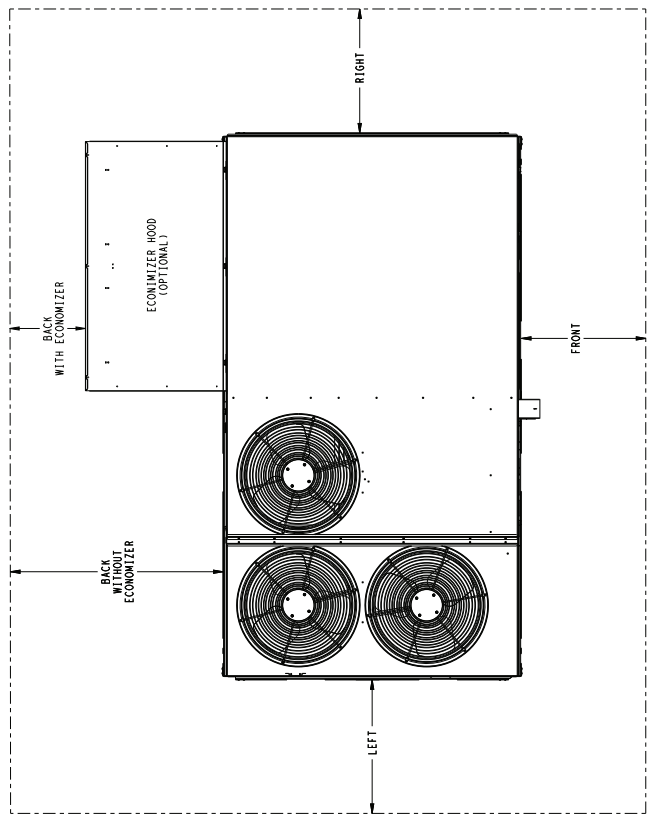

| SURFACE | CLEARANCE | |
|---------------|---------------------------------|------------------------------------|
| | SERVICE WITH CONDUCTIVE BARRIER | SERVICE WITH NONCONDUCTIVE BARRIER |
| FRONT | 48 [1219mm] | 36 [914mm] |
| LEFT | 48 [1219mm] | 42 [1067mm] |
| BACK W/O ECON | 48 [1219mm] | 36 [914mm] |
| BACK W/ECON | 36 [914mm] | 36 [914mm] |
| RIGHT | 36 [914mm] | 72 [1829mm] |
| TOP | 72 [1829mm] | 72 [1829mm] |

NOTE:
 1. FOR ALL MINIMUM CLEARANCES LOCAL CODES OR JURISDICTIONS MAY PREVAIL.

| TIC CLASSIFICATION | SHEET | DATE | SUPERCEDES | REV |
|--|--------|---------|------------|------------|
| U.S. ECCN:NSR | 3 OF 4 | 4/15/22 | 4/15/22 | - |
| 48LC 08 SINGLE ZONE ELECTRICAL COOLING WITH GAS HEAT | | | | 48LC001021 |

48LC*08 Base Unit Dimensions (cont)

THIS DOCUMENT IS THE PROPERTY OF CARRIER CORPORATION. SUBMISSION OF THESE DRAWINGS OR DOCUMENTS DOES NOT CONSTITUTE WARRANTY PERFORMANCE OR ACCEPTANCE OF CONTRACT. CONTENTS WILL NOT BE DISCLOSED OR USED WITHOUT CARRIER CORPORATION'S WRITTEN CONSENT.

DETAIL A
TYP. 4 PLCS

INSIDE BASE RAIL DIMENSIONS

BOTTOM

LEFT

FRONT

SEE DETAIL A

BACK

| I/T/C CLASSIFICATION | SHEET | DATE | SUPERCEDES | REV |
|--|--------|--------|------------|------------|
| U.S. ECCN: NSR | 4 OF 4 | 4/5/22 | 4/5/22 | 48LC001021 |
| 48LC 08 SINGLE ZONE ELECTRICAL COOLING WITH GAS HEAT | | | | - |

48LC*12 Base Unit Dimensions

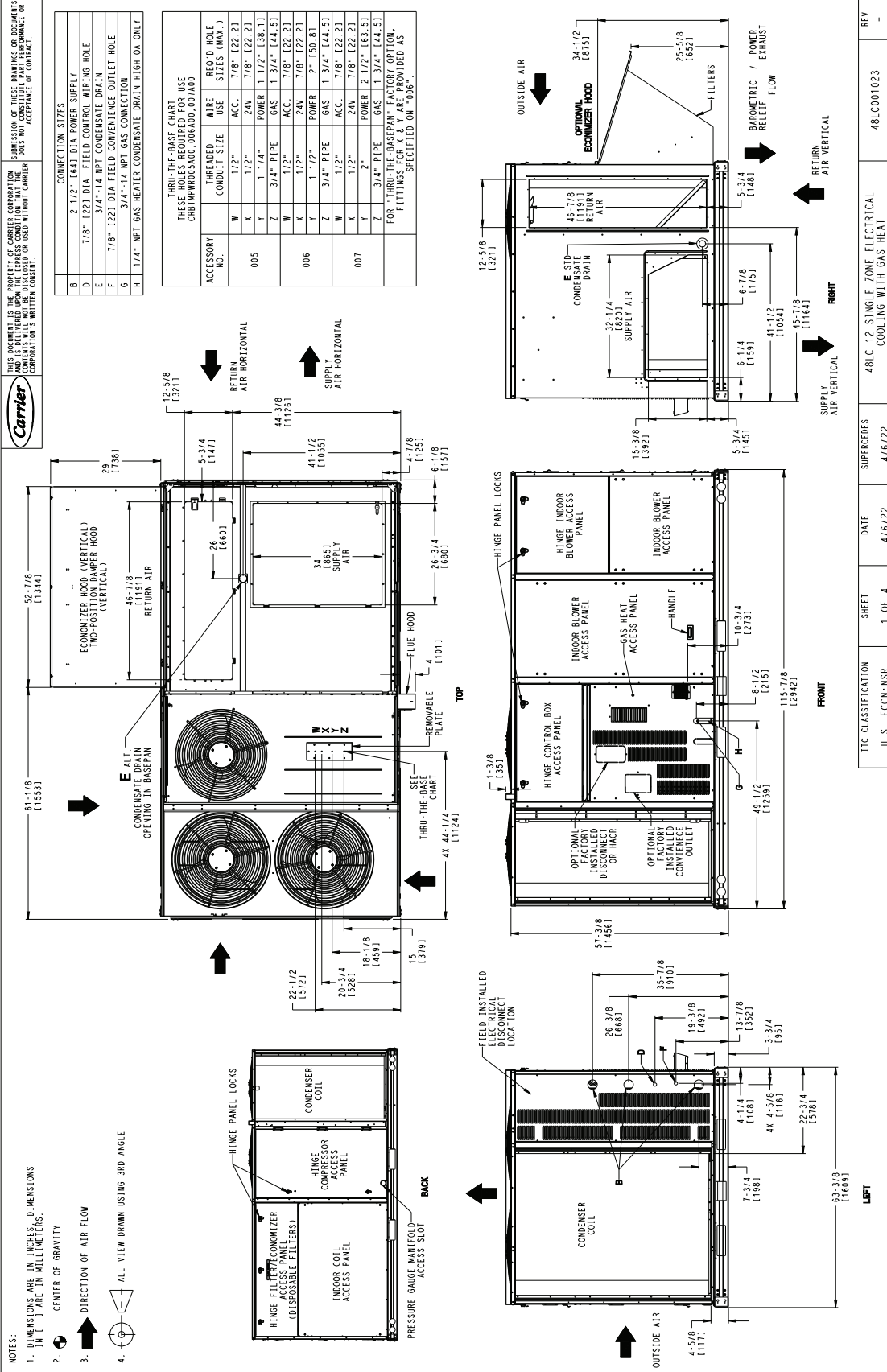

| | | | | |
|--------------------|--------|---------|------------|-----|
| ITC CLASSIFICATION | SHEET | DATE | SUPERCEDES | REV |
| U.S. ECCN:MSR | 1 OF 4 | 4/16/22 | 4/16/22 | - |

| | |
|--|------------|
| 48LC 12 SINGLE ZONE ELECTRICAL COOLING WITH GAS HEAT | 48LC001023 |
|--|------------|

48LC*12 Base Unit Dimensions (cont)

THIS DOCUMENT IS THE PROPERTY OF CARRIER CORPORATION AND IS DELIVERED UPON THE EXPRESS CONDITION THAT THE CONTENTS WILL NOT BE DISCLOSED OR USED WITHOUT CARRIER CORPORATION'S WRITTEN CONSENT.

SUBMISSION OF THESE DRAWINGS OR DOCUMENTS DOES NOT CONSTITUTE AN ACCEPTANCE OF PERFORMANCE OR ACCEPTANCE OF CONTRACT.

ITC CLASSIFICATION
U.S. ECCN: NSR

SHEET
2 OF 4

DATE
4/6/22

SUPERCEDES
4/6/22

48LC 12 SINGLE ZONE ELECTRICAL COOLING WITH GAS HEAT

48LC001023

REV
-

TOP

RIGHT

HORIZONTAL ECONOMIZER

48LC*12 Base Unit Dimensions (cont)

THIS DOCUMENT IS THE PROPERTY OF CARRIER CORPORATION. SUBMISSION OF THESE DRAWINGS OR DOCUMENTS DOES NOT CONSTITUTE PART PERFORMANCE OR ACCEPTANCE OF CONTRACT. CARRIER WILL NOT BE USED OR USED WITHOUT CARRIER CORPORATION'S WRITTEN CONSENT.



| UNIT | INSULATION | OUTDOOR COIL TYPE | STD. UNIT WEIGHT *** | | CORNER WEIGHT (A) | | CORNER WEIGHT (B) | | CORNER WEIGHT (C) | | CORNER WEIGHT (D) | | C.G. | | | | | |
|----------|-------------|-------------------|----------------------|-----|-------------------|-----|-------------------|-----|-------------------|-----|-------------------|-----|------|-----|----|-----|----|-----|
| | | | LBS. | KG. | LBS. | KG. | LBS. | KG. | LBS. | KG. | LBS. | KG. | X | Y | Z | | | |
| 48LC*H12 | FOIL FACE | R1PF | 1596 | 724 | 419 | 190 | 379 | 172 | 430 | 195 | 369 | 167 | 58 | 1/2 | 29 | 1/2 | 20 | 5/8 |
| 48LC*H12 | DOUBLE WALL | R1PF | 1787 | 811 | 446 | 202 | 444 | 201 | 504 | 229 | 393 | 178 | 60 | 1/4 | 29 | 1/2 | 20 | 5/8 |

*** STANDARD UNIT WEIGHT IS WITH LOW GAS HEAT AND WITHOUT PACKAGING. FOR OTHER OPTIONS AND ACCESSORIES, REFER TO THE PRODUCT DATA CATALOG.

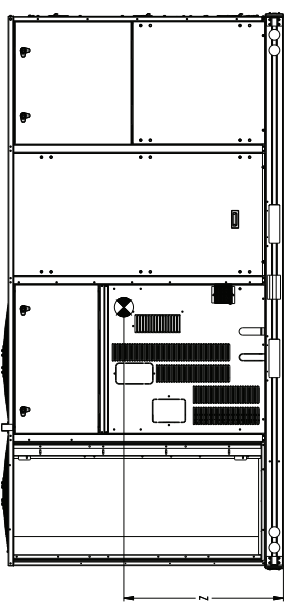
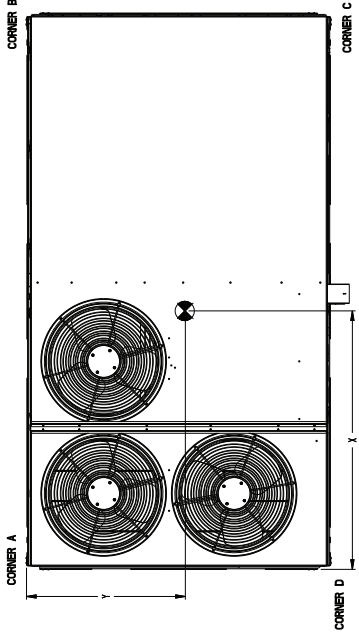
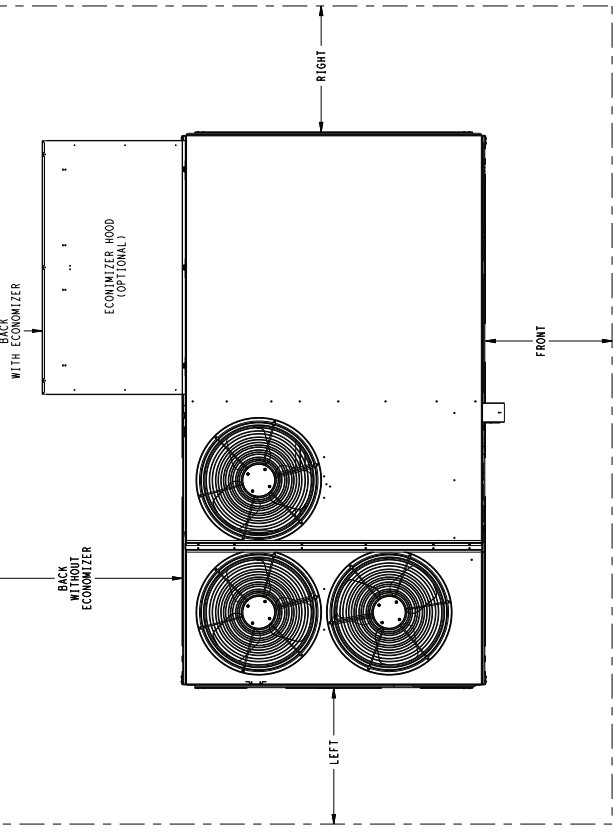

| SURFACE | CLEARANCE | |
|---------------|---------------------------------|------------------------------------|
| | SERVICE WITH CONDUCTIVE BARRIER | SERVICE WITH NONCONDUCTIVE BARRIER |
| FRONT | 48 [1219mm] | 36 [914mm] |
| LEFT | 48 [1219mm] | 42 [1067mm] |
| BACK W/O ECON | 48 [1219mm] | 42 [1067mm] |
| BACK W/ECON | 36 [914mm] | 36 [914mm] |
| RIGHT | 36 [914mm] | 36 [914mm] |
| TOP | 72 [1829mm] | 72 [1829mm] |

NOTE:
1. FOR ALL MINIMUM CLEARANCES LOCAL CODES OR JURISDICTIONS MAY PREVAIL.

| I/C CLASSIFICATION | SHEET | DATE | SUPERCEDES | DATE | U.S. ECCN: NSR | REV |
|--|--------|---------|------------|---------|----------------|-----|
| 48LC 12 SINGLE ZONE ELECTRICAL COOLING WITH GAS HEAT | 3 OF 4 | 4/16/22 | 4/16/22 | 4/16/22 | 48LC001023 | - |

48LC*12 Base Unit Dimensions (cont)

THIS DOCUMENT IS THE PROPERTY OF CARRIER CORPORATION. IT IS TO BE USED ONLY FOR THE PROJECT AND CONTENTS WILL NOT BE REPRODUCED OR USED WITHOUT CARRIER CORPORATION'S WRITTEN CONSENT.

SUBMISSION OF THESE DRAWINGS OR DOCUMENTS DOES NOT CONSTITUTE AN ACCEPTANCE OF CONTRACT.

DETAIL A
TYP. 4 PLCS

INSIDE BASERAIL DIMENSIONS

BOTTOM

BACK

LEFT

FRONT

BACK

LEFT

FRONT

| | | | | | | | | | | | |
|--------------------|----------------|-------|--------|------|--------|------------|--------|--|------------|-----|---|
| ITC CLASSIFICATION | U.S. ECCN: NSR | SHEET | 4 OF 4 | DATE | 4/6/22 | SUPERCEDES | 4/6/22 | 48LC 12 SINGLE ZONE ELECTRICAL COOLING WITH GAS HEAT | 48LC001023 | REV | - |
|--------------------|----------------|-------|--------|------|--------|------------|--------|--|------------|-----|---|

50LC*07 Base Unit Dimensions

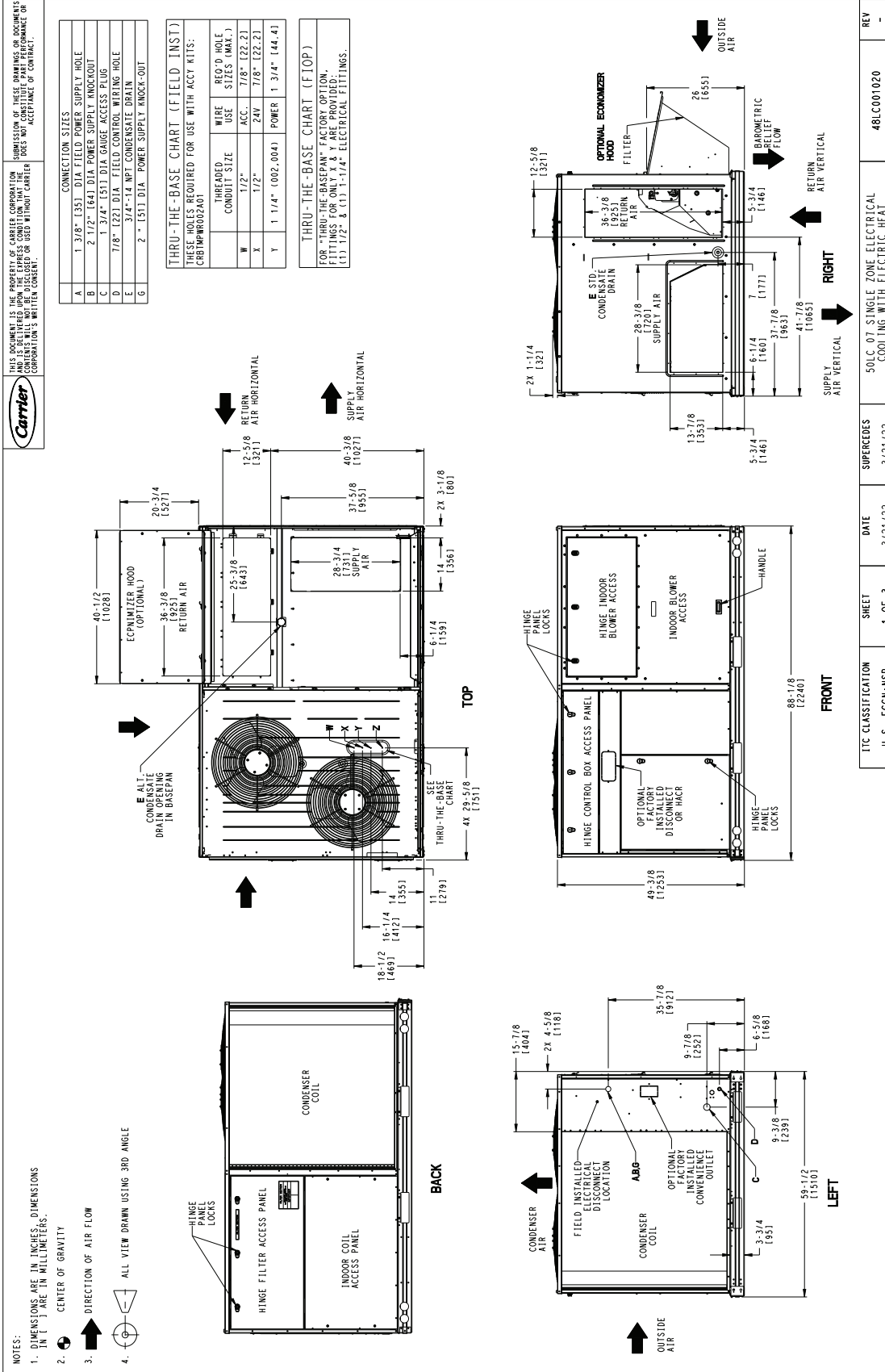

50LC*07 Base Unit Dimensions (cont)

THIS DOCUMENT IS THE PROPERTY OF CARRIER CORPORATION. CONTENTS SHALL NOT BE REPRODUCED OR USED WITHOUT CARRIER CORPORATION'S WRITTEN CONSENT.



SUBMISSION OF THESE DRAWINGS OR DOCUMENTS DOES NOT CONSTITUTE PART PERFORMANCE OR ACCEPTANCE OF CONTRACT.

| UNIT | INSULATION | OUTDOOR COIL TYPE | STD. UNIT WEIGHT *** | | CORNER WEIGHT (A) | | CORNER WEIGHT (B) | | CORNER WEIGHT (C) | | CORNER WEIGHT (D) | | C.G. | | | | |
|----------|-------------|-------------------|----------------------|-----|-------------------|-----|-------------------|-----|-------------------|-----|-------------------|-----|------|----|-----|----|-----|
| | | | LBS. | KG. | LBS. | KG. | LBS. | KG. | LBS. | KG. | LBS. | KG. | X | Y | Z | | |
| 50LC*H07 | FOIL FACE | RTPF | 999 | 454 | 389 | 176 | 141 | 64 | 222 | 101 | 247 | 112 | 42 | 24 | 1/2 | 20 | 3/4 |
| 50LC*H07 | DOUBLE WALL | RTPF | 1143 | 518 | 426 | 193 | 173 | 79 | 272 | 123 | 271 | 123 | 45 | 24 | 1/2 | 20 | 3/4 |

*** STANDARD UNIT WEIGHT IS WITH LOW GAS HEAT AND WITHOUT PACKAGING. FOR OTHER OPTIONS AND ACCESSORIES, REFER TO THE PRODUCT DATA CATALOG.

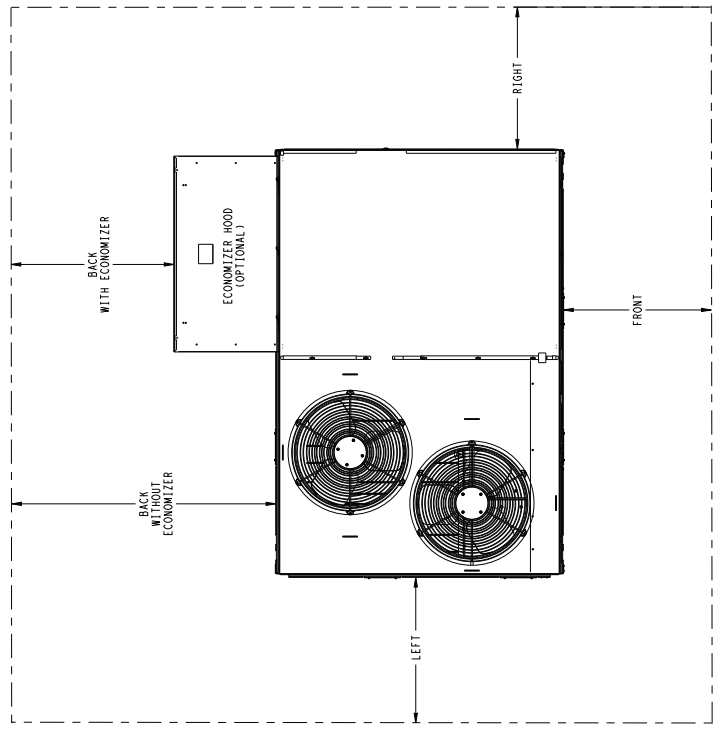
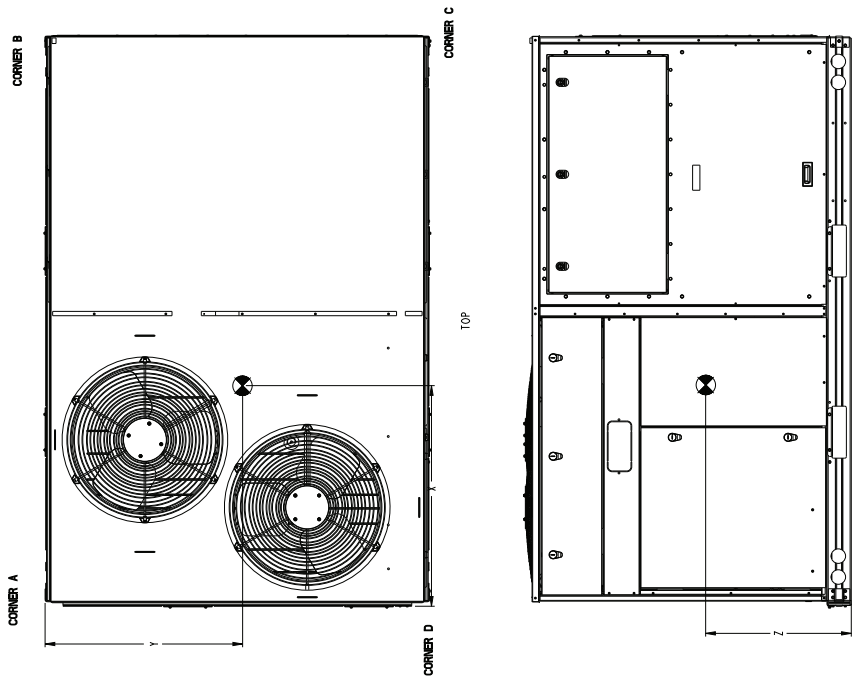

| SURFACE | CLEARANCE | |
|---------------|---------------------------------|------------------------------------|
| | SERVICE WITH CONDUCTIVE BARRIER | SERVICE WITH NONCONDUCTIVE BARRIER |
| FRONT | 48 [1219mm] | 36 [914mm] |
| LEFT | 48 [1219mm] | 42 [1067mm] |
| BACK W/O ECON | 48 [1219mm] | 42 [1067mm] |
| BACK W/ECON | 36 [914mm] | 36 [914mm] |
| RIGHT | 36 [914mm] | 36 [914mm] |
| TOP | 72 [1829mm] | 72 [1829mm] |

| EITC CLASSIFICATION | SHEET | DATE | DATE | DATE | REV |
|---------------------|--------|---------|---------|---------|------------|
| U.S. - ECCN:NSR | 2 OF 3 | 3/21/22 | 3/21/22 | 3/21/22 | 48LC001020 |

NOTE:
1. FOR ALL MINIMUM CLEARANCES LOCAL CODES OR JURISDICTIONS MAY PREVAIL.

50LC*07 Base Unit Dimensions (cont)

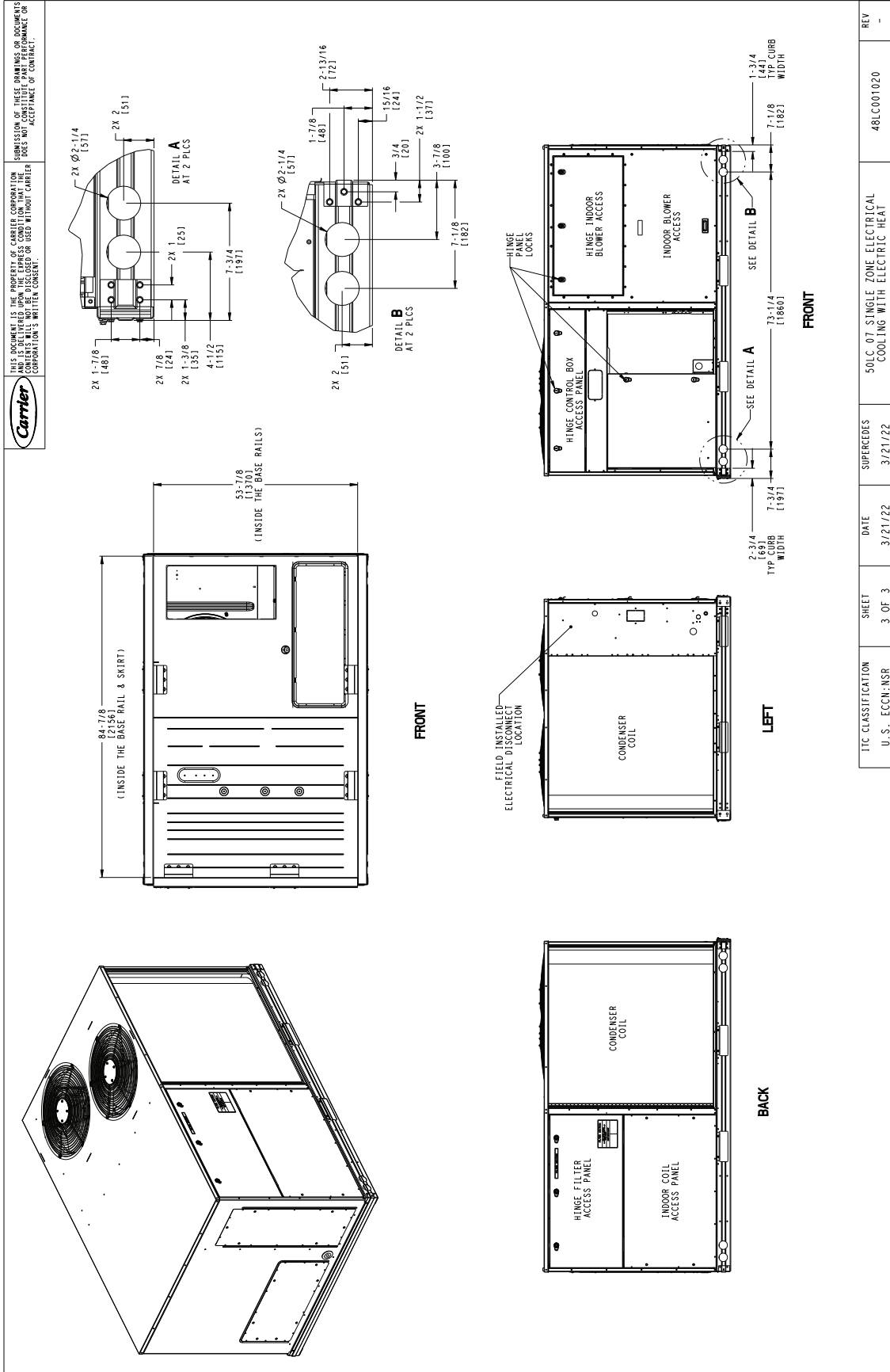

50LC*08 Base Unit Dimensions

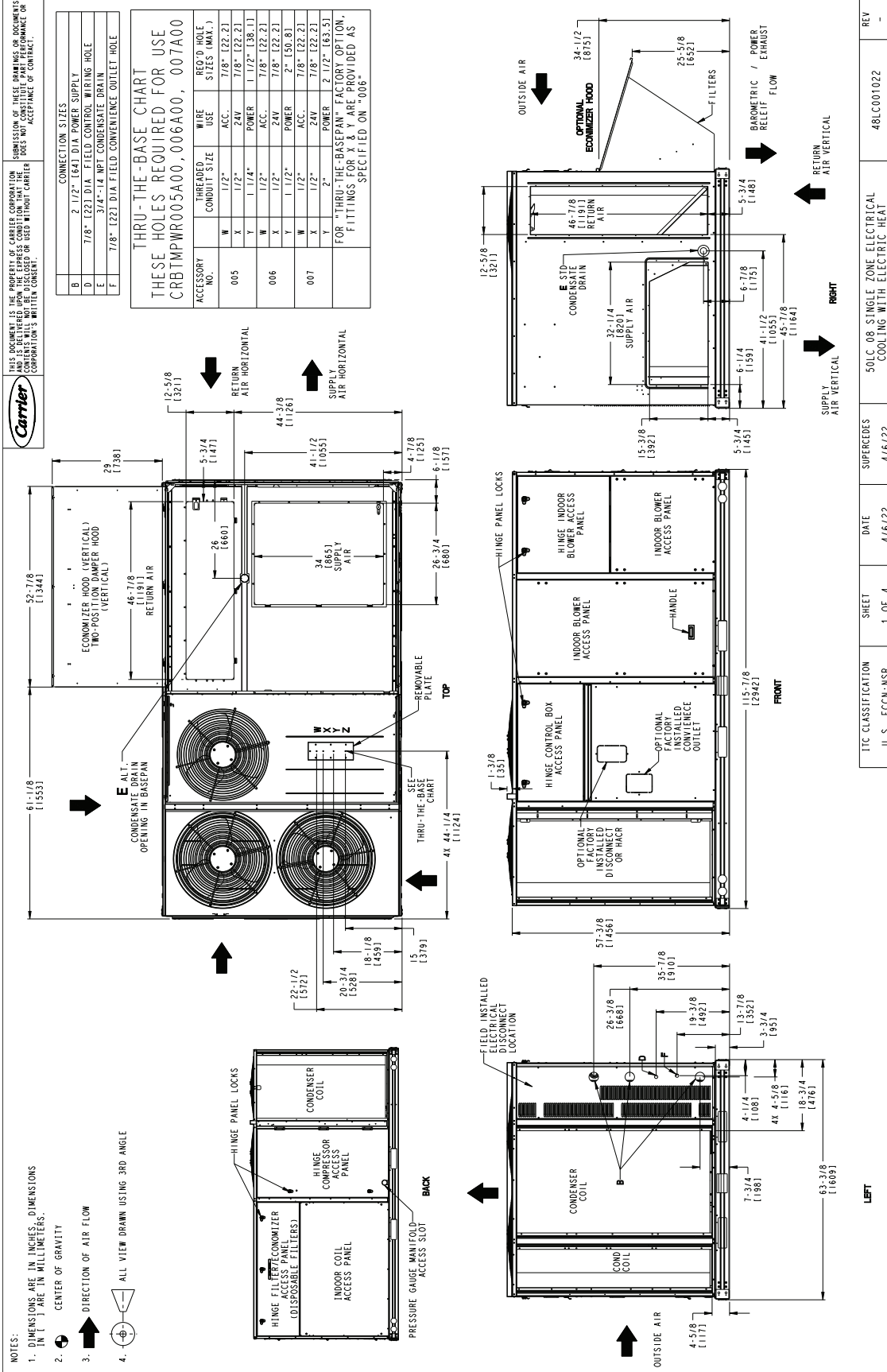

50LC*08 Base Unit Dimensions (cont)

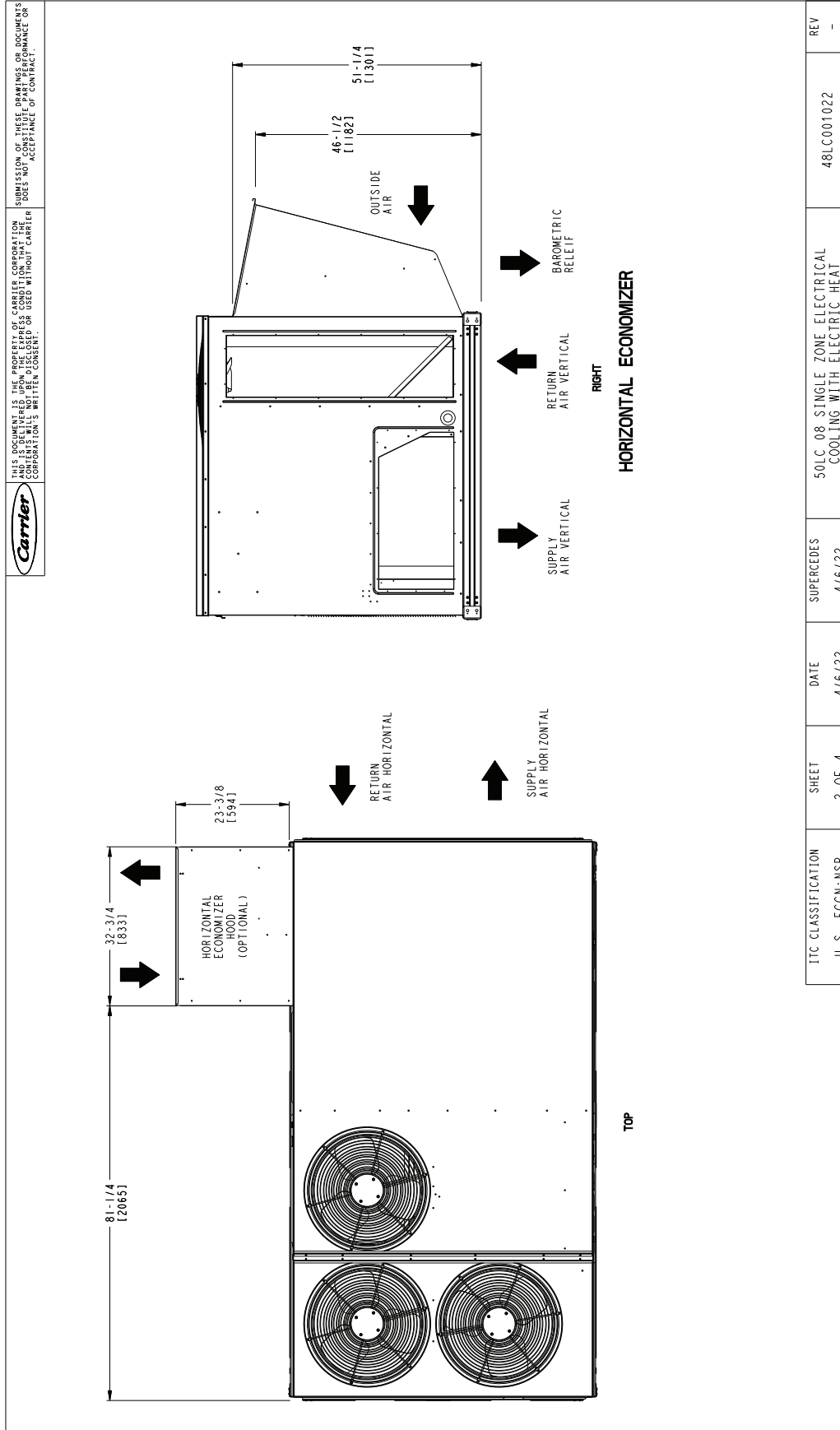

50LC*08 Base Unit Dimensions (cont)

Carrier
 THIS DOCUMENT IS THE PROPERTY OF CARRIER CORPORATION AND IS DELIVERED UPON THE EXPRESS CONDITION THAT THE USER WILL NOT REPRODUCE OR TRANSMIT IN ANY MANNER WITHOUT CARRIER CORPORATION'S WRITTEN CONSENT.

| UNIT | INSULATION | OUTDOOR COIL TYPE | STD. UNIT WEIGHT *** | | CORNER WEIGHT (A) | | CORNER WEIGHT (B) | | CORNER WEIGHT (C) | | CORNER WEIGHT (D) | | C.G. | | | | | |
|----------|-------------|-------------------|----------------------|-----|-------------------|-----|-------------------|-----|-------------------|-----|-------------------|-----|------|-----|----|-----|----|-----|
| | | | LBS. | KG. | LBS. | KG. | LBS. | KG. | LBS. | KG. | LBS. | KG. | X | Y | Z | | | |
| 50LC-H08 | FOIL FACE | R1PF | 1453 | 659 | 376 | 171 | 350 | 159 | 373 | 169 | 353 | 160 | 57 | 1/2 | 30 | 1/2 | 20 | 5/8 |
| 50LC-H08 | DOUBLE WALL | R1PF | 1644 | 746 | 404 | 183 | 417 | 189 | 444 | 202 | 379 | 172 | 60 | 1/2 | 30 | 1/2 | 20 | 5/8 |

*** STANDARD UNIT WEIGHT IS WITH LOW GAS HEAT AND WITHOUT PACKAGING. FOR OTHER OPTIONS AND ACCESSORIES, REFER TO THE PRODUCT DATA CATALOG.

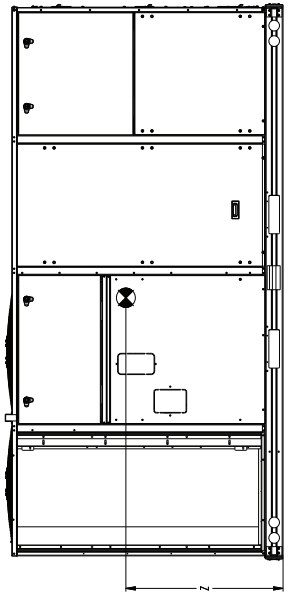
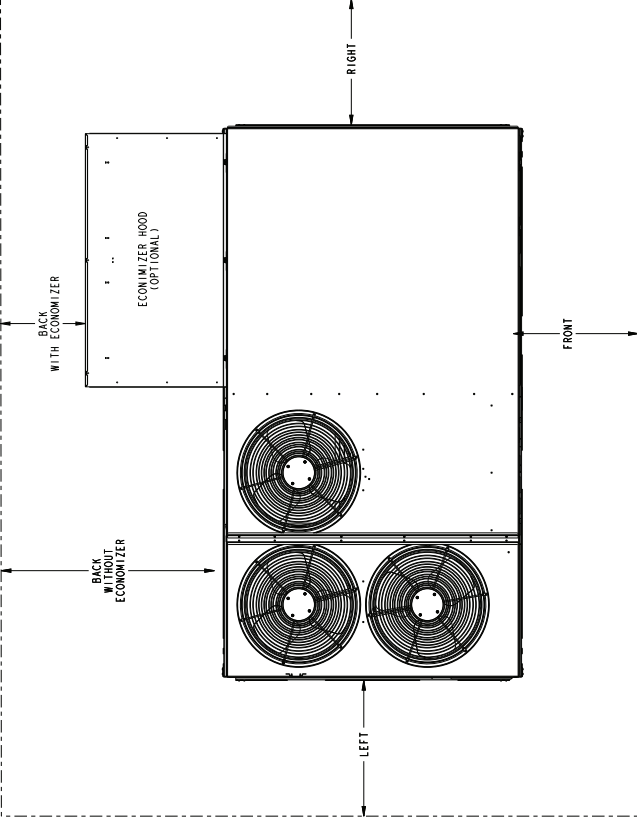
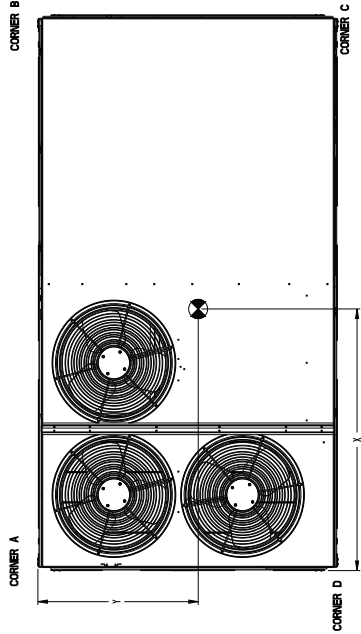

| SURFACE | CLEARANCE | |
|---------------|---------------------------------|------------------------------------|
| | SERVICE WITH CONDUCTIVE BARRIER | SERVICE WITH NONCONDUCTIVE BARRIER |
| FRONT | 48 [1219mm] | 36 [914mm] |
| LEFT | 48 [1219mm] | 42 [1067mm] |
| BACK W/O ECON | 48 [1219mm] | 42 [1067mm] |
| BACK W/ECON | 36 [914mm] | 36 [914mm] |
| RIGHT | 36 [914mm] | 36 [914mm] |
| TOP | 72 [1829mm] | 72 [1829mm] |

NOTE:
 1. FOR ALL MINIMUM CLEARANCES LOCAL CODES OR JURISDICTIONS MAY PREVAIL.

| | | | | | |
|--------------------|--------|--------|--------|--------|------------|
| ITC CLASSIFICATION | SHEET | DATE | DATE | DATE | REV |
| U.S. ECCN:NSR | 3 OF 4 | 4/5/22 | 4/5/22 | 4/5/22 | 48LC001022 |

50LC*08 Base Unit Dimensions (cont)

THIS DOCUMENT IS THE PROPERTY OF CARRIER CORPORATION. IT IS TO BE USED ONLY FOR THE PROJECT AND IS TO BE RETURNED TO CARRIER CORPORATION UPON THE COMPLETION OF THE PROJECT. IT IS NOT TO BE REPRODUCED OR TRANSMITTED IN ANY FORM OR BY ANY MEANS, ELECTRONIC OR MECHANICAL, INCLUDING PHOTOCOPYING, RECORDING, OR BY ANY INFORMATION STORAGE AND RETRIEVAL SYSTEM, WITHOUT THE WRITTEN CONSENT OF CARRIER CORPORATION.

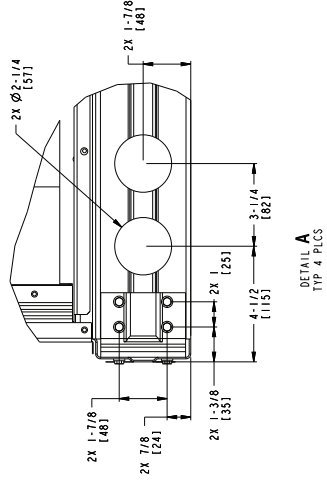
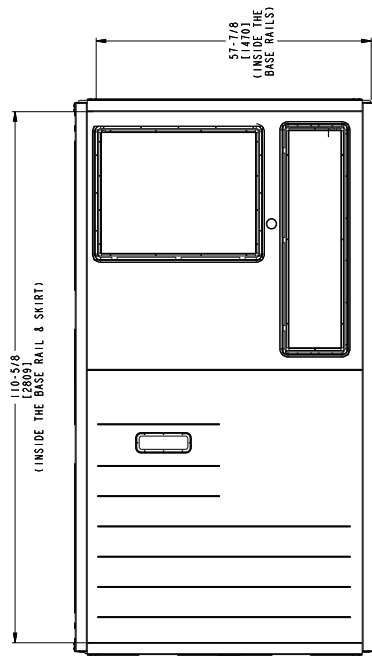
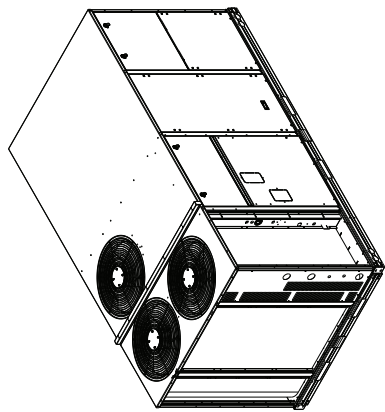

DETAIL A
TYP. 4 PLCS

INSIDE BASERAIL DIMENSIONS

BOTTOM

FIELD-INSTALLED ELECTRICAL DISCONNECT LOCATION

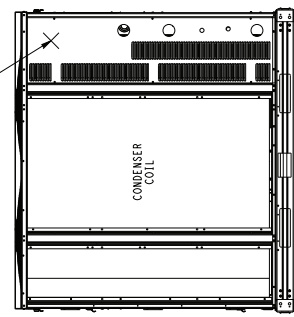

SCALE 3:32

LEFT

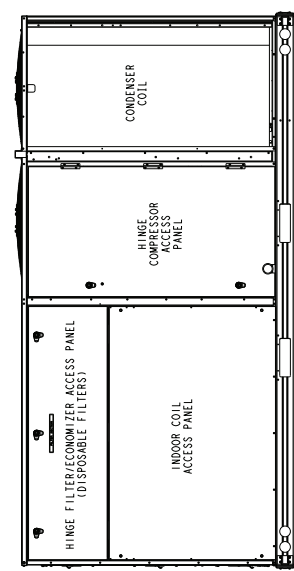

BACK

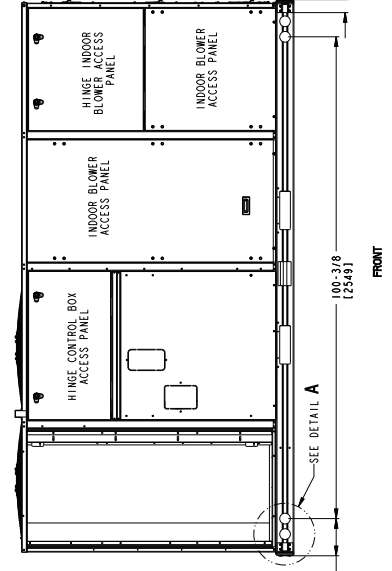

FRONT

| ITC CLASSIFICATION | SHEET | DATE | SUPERCEDES | REV |
|---|--------|---------|------------|------------|
| U.S. ECCN: NSR | 4 OF 4 | 4/16/22 | 4/16/22 | 48LC001022 |
| 50LC_08_SINGLE_ZONE_ELECTRICAL_COOLING_WITH_ELECTRICAL_HEAT | | | | - |

50LC*12 Base Unit Dimensions

NOTES:

1. DIMENSIONS ARE IN INCHES. DIMENSIONS IN PARENTHESIS ARE IN MILLIMETERS.
2. CENTER OF GRAVITY
3. DIRECTION OF AIR FLOW
4. ALL VIEW DRAWN USING 3RD ANGLE

THIS DOCUMENT IS THE PROPERTY OF CARRIER CORPORATION. SUBMISSION OF THESE DRAWINGS OR DOCUMENTS DOES NOT CONSTITUTE PART PERFORMANCE OR ACCEPTANCE OF CONTRACT. CONTENTS WILL NOT BE DISCLOSED OR USED WITHOUT CARRIER CORPORATION'S WRITTEN CONSENT.

Carrier

CONNECTION SIZES

| | |
|---|---|
| B | 2-1/2" E64J DIA POWER SUPPLY |
| D | 7/8" E221 DIA FIELD CONTROL WIRING HOLE |
| E | 3/4" - 1/4 NPT CONDENSATE DRAIN |
| F | 7/8" E221 DIA FIELD CONVENIENCE OUTLET HOLE |

THRU-THE-BASE CHART

THESE HOLES REQUIRED FOR USE
CRB1MPWR005A00, 006A00, 007A00

| ACCESSORY NO. | THREADED CONDUIT SIZE | WIRE USE | REQ'D HOLE SIZES (MIN.) |
|---------------|-----------------------|----------|-------------------------|
| 005 | W 1/2" | ACC. | 7/8" - 1/2 (222.2) |
| | X 1/2" | 24V | 7/8" - 1/2 (222.2) |
| | Y 1/4" | POWER | 1-1/2" - 1/8 (138.1) |
| 006 | W 1/2" | ACC. | 7/8" - 1/2 (222.2) |
| | X 1/2" | 24V | 7/8" - 1/2 (222.2) |
| | Y 1/4" | POWER | 2-1/8" - 1/8 (150.8) |
| 007 | W 1/2" | ACC. | 7/8" - 1/2 (222.2) |
| | X 1/2" | 24V | 7/8" - 1/2 (222.2) |
| | Y 1/4" | POWER | 2-1/2" - 1/8 (163.5) |

FOR THRU-THE-BASE PAN FACTORY OPTION, FITTINGS FOR THE BASE ARE PROVIDED AS SPECIFIED ON "006"

TOP

FRONT

LEFT

RIGHT

BACK

REV

| | | | | | | | | | | |
|--------------------|---------------|-------|--------|------|---------|------------|---------|---|-----|------------|
| TIC CLASSIFICATION | U.S. ECCN-NSR | SHEET | 1 OF 4 | DATE | 4/16/22 | SUPERCEDES | 4/16/22 | 50LC 12 SINGLE ZONE ELECTRICAL COOLING WITH ELECTRIC HEAT | REV | 48LC001024 |
|--------------------|---------------|-------|--------|------|---------|------------|---------|---|-----|------------|

50LC*12 Base Unit Dimensions (cont)

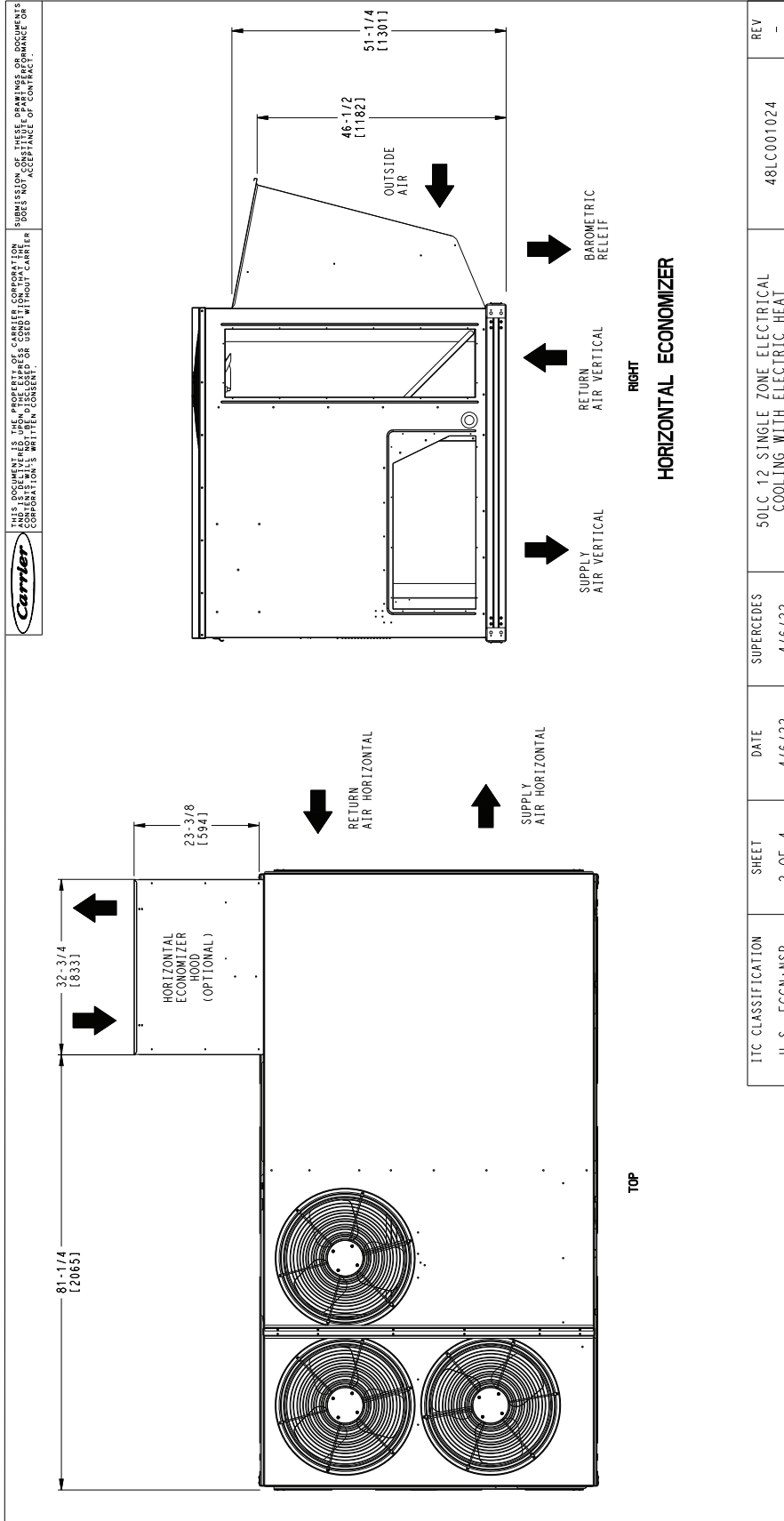

Carrier
 ALL DIMENSIONS ARE TO FACE UNLESS OTHERWISE SPECIFIED. DIMENSIONS TO FACE ARE TO BE USED FOR FABRICATION AND INSTALLATION. DIMENSIONS TO CENTERLINE ARE TO BE USED FOR ALIGNMENT. DIMENSIONS TO CENTERLINE ARE TO BE USED FOR ALIGNMENT. DIMENSIONS TO CENTERLINE ARE TO BE USED FOR ALIGNMENT. DIMENSIONS TO CENTERLINE ARE TO BE USED FOR ALIGNMENT.

SUBMISSION OF THESE DRAWINGS OR DOCUMENTS DOES NOT CONSTITUTE AN ACCEPTANCE OF CONTRACT.

| ITC CLASSIFICATION | SHEET | DATE | SUPERCEDES | REV |
|---|--------|--------|------------|------------|
| U.S. ECCN: NSR | 2 OF 4 | 4/6/22 | 4/6/22 | 48LC001024 |
| 50LC 12 SINGLE ZONE ELECTRICAL COOLING WITH ELECTRIC HEAT | | | | - |

50LC*12 Base Unit Dimensions (cont)

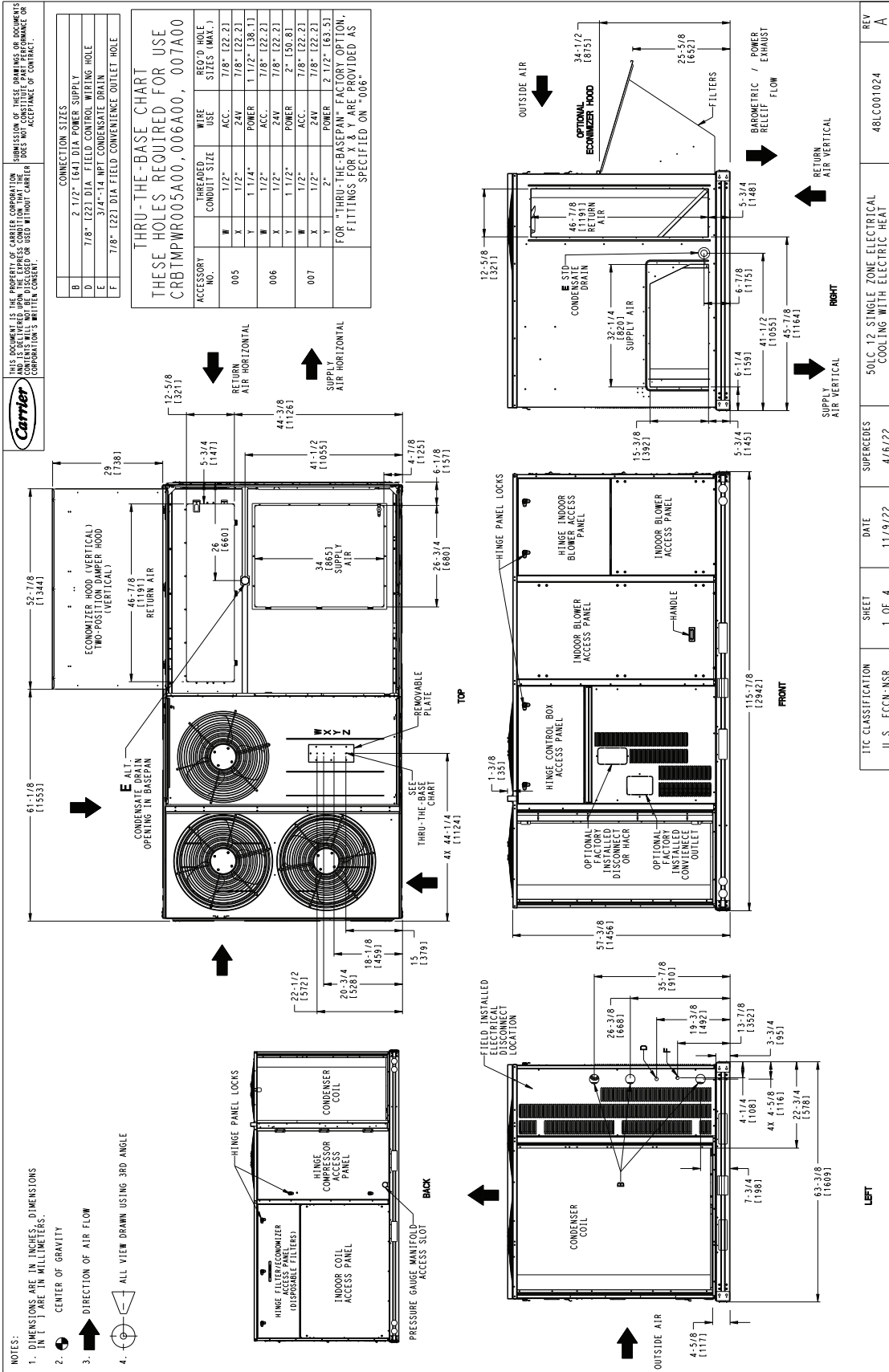

50LC*12 Base Unit Dimensions (cont)

Carrier
 THIS DOCUMENT IS THE PROPERTY OF CARRIER CORPORATION. SUBMISSION OF THESE DRAWINGS OR DOCUMENTS DOES NOT CONSTITUTE PART PERFORMANCE OR ACCEPTANCE OF CONTRACT. CONTENTS WILL NOT BE DISCLOSED OR USED WITHOUT CARRIER CORPORATION'S WRITTEN CONSENT.

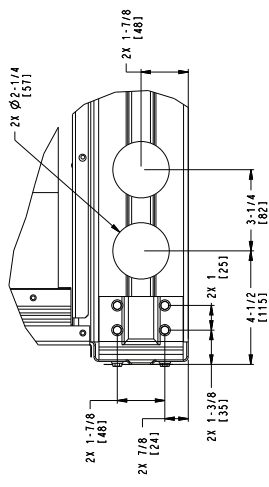
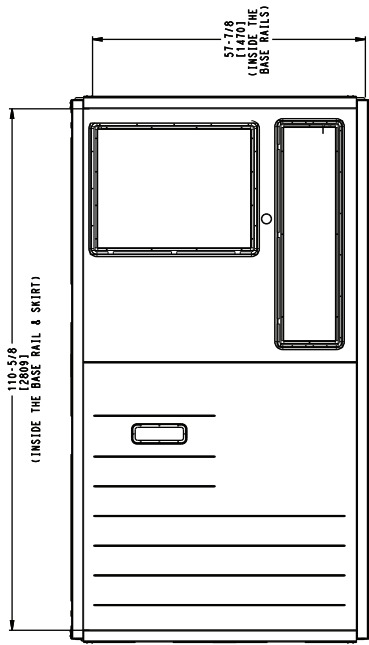
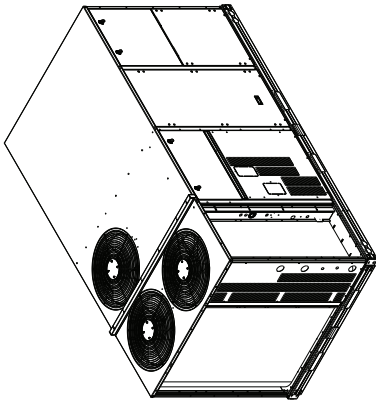

DETAIL A
 TYP. 4 PLCS

INSIDE BASERAIL DIMENSIONS

BOTTOM

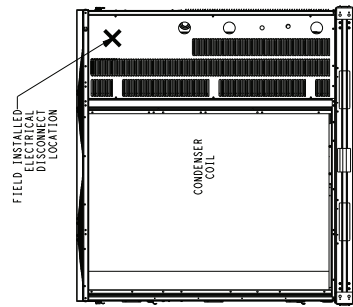

SCALE 3:32

LEFT

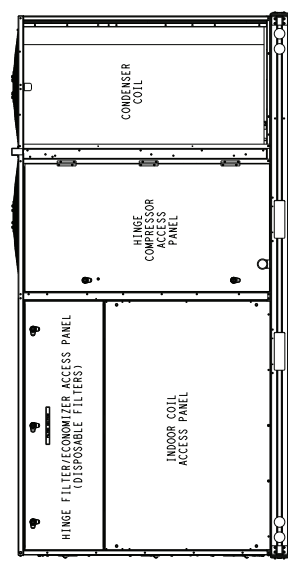

BACK

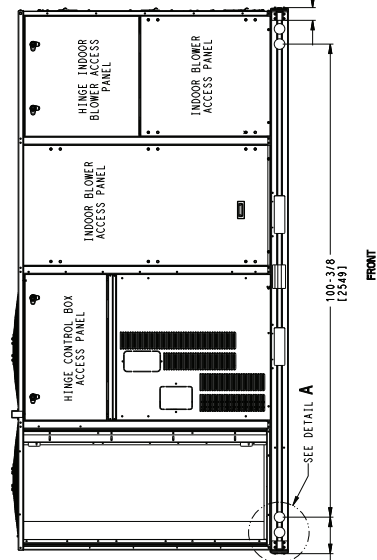

SEE DETAIL A

FRONT

| ITC CLASSIFICATION | SHEET | DATE | SUPERSEDES | REV |
|---|--------|---------|------------|------------|
| U.S. ECCN: NSR | 4 OF 4 | 4/16/22 | 4/16/22 | 48LC001024 |
| 50LC.12 SINGLE ZONE ELECTRICAL COOLING WITH ELECTRIC HEAT | | | | REV |
| | | | | - |

Service Clearance Dimensions

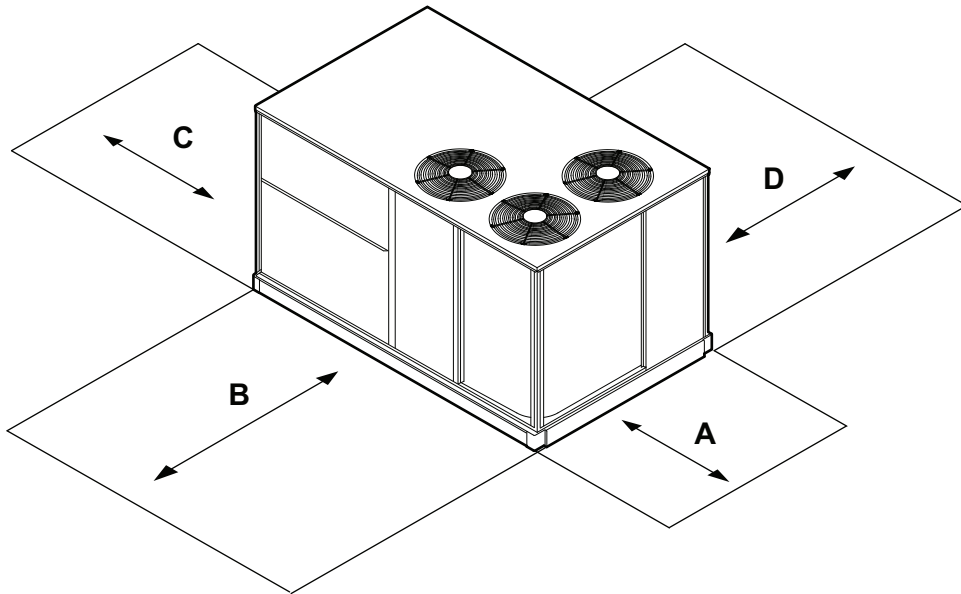

| LOCATION | DIMENSION ^{a,b} | CONDITION |
|----------|--------------------------|---|
| A | 48 in. (1219 mm) | Unit disconnect is mounted on panel. |
| | 18 in. (457 mm) | No disconnect, convenience outlet option. |
| | 18 in. (457 mm) | Recommended service clearance. |
| | 12 in. (305 mm) | Minimum clearance. |
| B | 40 in. (1067 mm) | Surface behind servicer is grounded (e.g., metal, masonry wall). |
| | 36 in. (914 mm) | Surface behind servicer is electrically non-conductive (e.g., wood, fiberglass). |
| | Special | Check sources of flue products within 10 ft (3 m) of unit fresh air intake hood. |
| C | 36 in. (914 mm) | Side condensate drain is used. |
| | 18 in. (457 mm) | Minimum clearance. |
| D | 48 in. (1219 mm) | No flue discharge accessory installed, surface is combustible material. |
| | 42 in. (1067 mm) | Surface behind servicer is grounded (e.g., metal, masonry wall, another unit). |
| | 36 in. (914 mm) | Surface behind servicer is electrically non-conductive (e.g., wood, fiberglass). |
| | Special | Check for adjacent units or building fresh air intakes within 10 ft (3 m) of this unit's flue outlet. |

NOTE(S):

- a. Unit not designed to have overhead obstruction. Contact Application Engineering for guidance on any application planning overhead obstruction or for vertical clearances.
- b. The number of fans varies with the unit size. Depending on size, unit will have two or three fans.

Static Pressure Adders (in. wg) (Factory Options and/or Accessories)

48/50LC*H 07 Pressure Drop For Low Leak Economizer

| AIR FLOW (cfm) | 1000 | 1200 | 1400 | 1600 | 1800 | 2000 | 2200 | 2400 |
|------------------------|-------|-------|-------|-------|-------|-------|-------|-------|
| PRESSURE DROP (in. wg) | 0.001 | 0.007 | 0.015 | 0.025 | 0.038 | 0.052 | 0.068 | 0.086 |

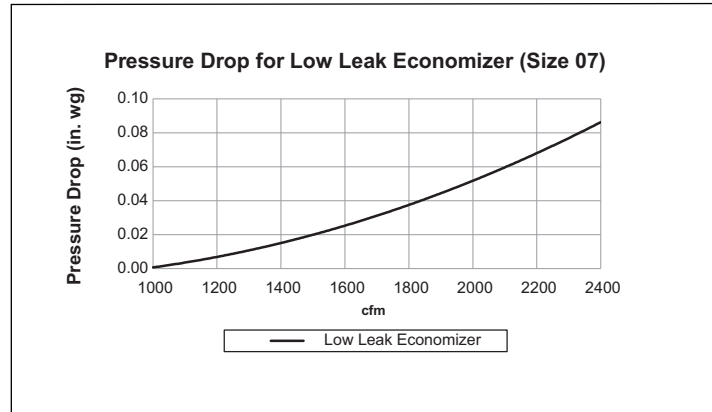

48/50LC*H 08-12 Pressure Drop For Low Leak Economizer

| AIR FLOW (cfm) | 1200 | 1500 | 1800 | 2100 | 2400 | 2700 | 3000 | 3300 | 3500 |
|------------------------|-------|-------|-------|-------|-------|-------|-------|-------|-------|
| PRESSURE DROP (in. wg) | 0.002 | 0.003 | 0.004 | 0.006 | 0.008 | 0.010 | 0.013 | 0.016 | 0.018 |

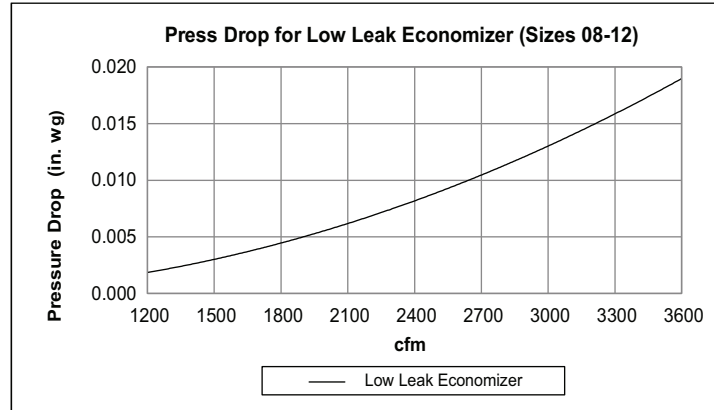

Static Pressure Adders (in. wg) (Factory Options and/or Accessories) (cont)

50LC*H 07 Pressure Drop For Electric Heat (Vertical and Horizontal Discharge)

| AIR FLOW (cfm) | 1000 | 1100 | 1200 | 1300 | 1400 | 1500 | 1600 | 1700 | 1800 | 1900 | 2000 |
|----------------------|-------|-------|-------|-------|-------|-------|-------|-------|-------|-------|-------|
| LOW HEAT (MODULE 1) | 0.010 | 0.012 | 0.014 | 0.015 | 0.017 | 0.019 | 0.021 | 0.024 | 0.026 | 0.028 | 0.031 |
| HIGH HEAT (MODULE 2) | 0.015 | 0.017 | 0.019 | 0.021 | 0.023 | 0.026 | 0.028 | 0.031 | 0.033 | 0.036 | 0.039 |

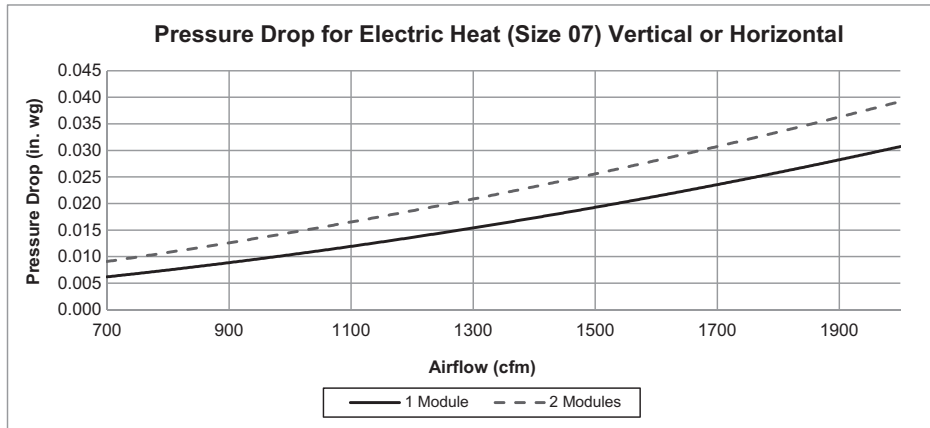

50LC*H 08-12 Pressure Drop For Electric Heat (Vertical Discharge)

| AIR FLOW (cfm) | 1300 | 1500 | 1700 | 1900 | 2100 | 2300 | 2500 | 2700 | 2900 | 3100 | 3300 |
|----------------------|-------|-------|-------|-------|-------|-------|-------|-------|-------|-------|-------|
| LOW HEAT (MODULE 1) | 0.005 | 0.006 | 0.007 | 0.008 | 0.009 | 0.010 | 0.011 | 0.012 | 0.013 | 0.014 | 0.015 |
| HIGH HEAT (MODULE 2) | 0.008 | 0.009 | 0.011 | 0.013 | 0.014 | 0.016 | 0.018 | 0.020 | 0.020 | 0.025 | 0.028 |

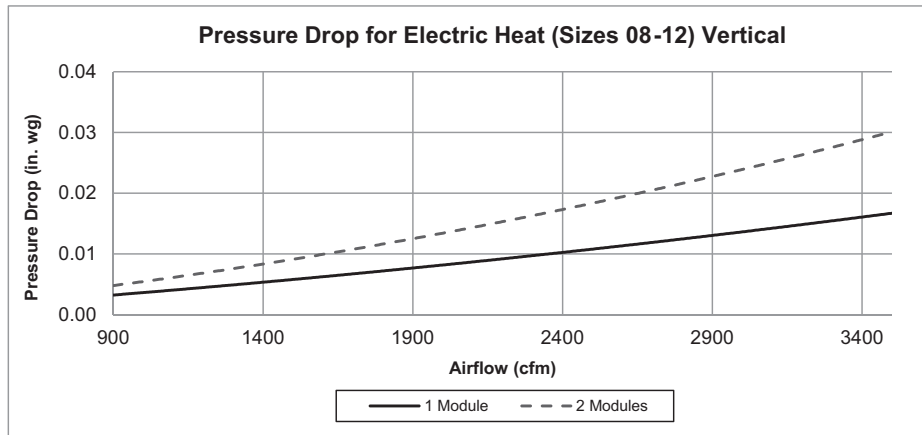

Static Pressure Adders (in. wg) (Factory Options and/or Accessories) (cont)

48LC*H 07 Pressure Drop For Gas Heat

| AIR FLOW (cfm) | 1000 | 1100 | 1200 | 1300 | 1400 | 1500 | 1600 | 1700 | 1800 | 1900 | 2000 |
|----------------------|-------|-------|-------|-------|-------|-------|-------|-------|-------|-------|-------|
| LOW HEAT (3 CELL) | 0.008 | 0.009 | 0.010 | 0.011 | 0.012 | 0.013 | 0.015 | 0.016 | 0.017 | 0.019 | 0.020 |
| MEDIUM HEAT (5 CELL) | 0.010 | 0.012 | 0.014 | 0.016 | 0.018 | 0.020 | 0.023 | 0.025 | 0.028 | 0.030 | 0.033 |
| HIGH HEAT (7 CELL) | 0.033 | 0.037 | 0.042 | 0.046 | 0.051 | 0.055 | 0.060 | 0.065 | 0.071 | 0.076 | 0.081 |

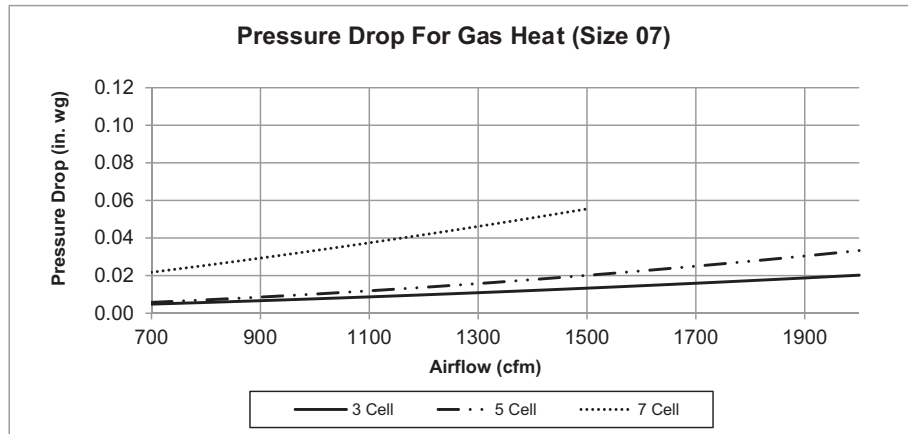

48LC*H 08-12 Pressure Drop For Gas Heat

| AIR FLOW (cfm) | 1300 | 1500 | 1700 | 1900 | 2100 | 2300 | 2500 | 2700 | 2900 | 3100 | 3300 |
|---|-------|-------|-------|-------|-------|-------|-------|-------|-------|-------|-------|
| LOW HEAT - 08 (4 CELL) | 0.013 | 0.017 | 0.020 | 0.023 | 0.027 | 0.031 | 0.036 | 0.041 | 0.045 | 0.051 | 0.056 |
| MEDIUM HEAT - 08/LOW HEAT - 12 (6 CELL) | 0.018 | 0.023 | 0.027 | 0.032 | 0.038 | 0.044 | 0.050 | 0.056 | 0.063 | 0.071 | 0.079 |
| HIGH HEAT - 08/ MEDIUM HEAT - 12 (8 CELL) | 0.022 | 0.027 | 0.032 | 0.038 | 0.045 | 0.052 | 0.060 | 0.068 | 0.076 | 0.085 | 0.095 |
| HIGH HEAT - 12 (10 CELL) | 0.034 | 0.042 | 0.050 | 0.060 | 0.069 | 0.080 | 0.091 | 0.103 | 0.116 | 0.129 | 0.143 |

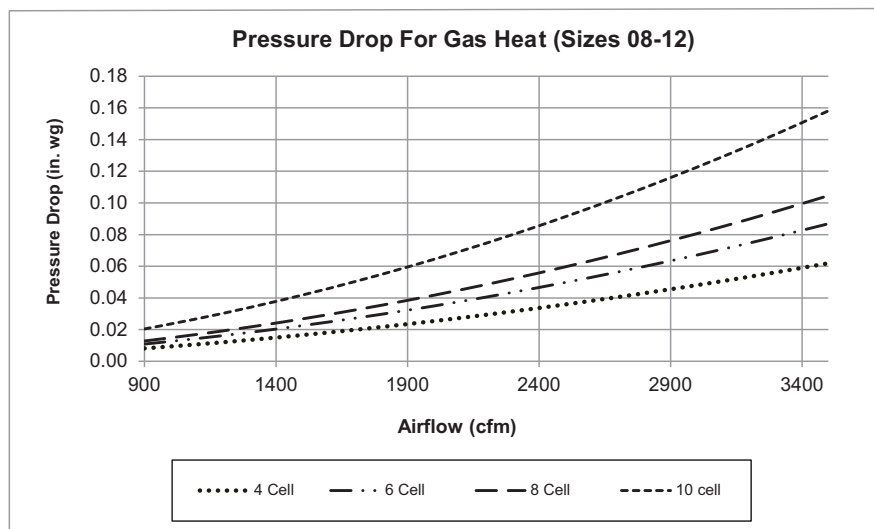

Static Pressure Adders (in. wg) (Factory Options and/or Accessories) (cont)

48LC*H 07 Pressure Drop For 4 in. Filters

| AIR FLOW (cfm) | 1000 | 1100 | 1200 | 1300 | 1400 | 1500 | 1600 | 1700 | 1800 | 1900 | 2000 |
|----------------|-------|-------|-------|-------|-------|-------|-------|-------|-------|-------|-------|
| MERV 8 | 0.019 | 0.022 | 0.024 | 0.027 | 0.030 | 0.033 | 0.036 | 0.039 | 0.043 | 0.046 | 0.050 |
| MERV 13 | 0.077 | 0.086 | 0.095 | 0.104 | 0.113 | 0.122 | 0.131 | 0.140 | 0.150 | 0.160 | 0.169 |

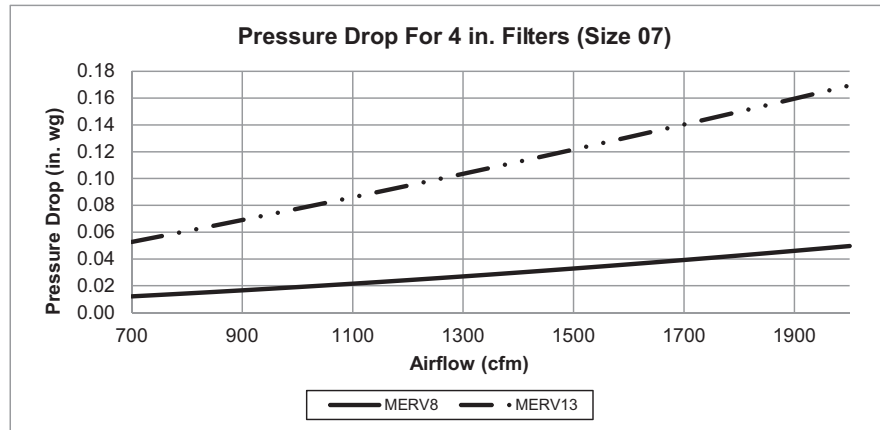

48LC*H 08-12 Pressure Drop For 4 in. Filters

| AIR FLOW (cfm) | 1300 | 1500 | 1700 | 1900 | 2100 | 2300 | 2500 | 2700 | 2900 | 3100 | 3300 |
|----------------|-------|-------|-------|-------|-------|-------|-------|-------|-------|-------|-------|
| MERV 8 | 0.015 | 0.018 | 0.021 | 0.024 | 0.028 | 0.032 | 0.035 | 0.040 | 0.044 | 0.048 | 0.053 |
| MERV 13 | 0.063 | 0.073 | 0.084 | 0.095 | 0.106 | 0.118 | 0.130 | 0.141 | 0.154 | 0.166 | 0.179 |

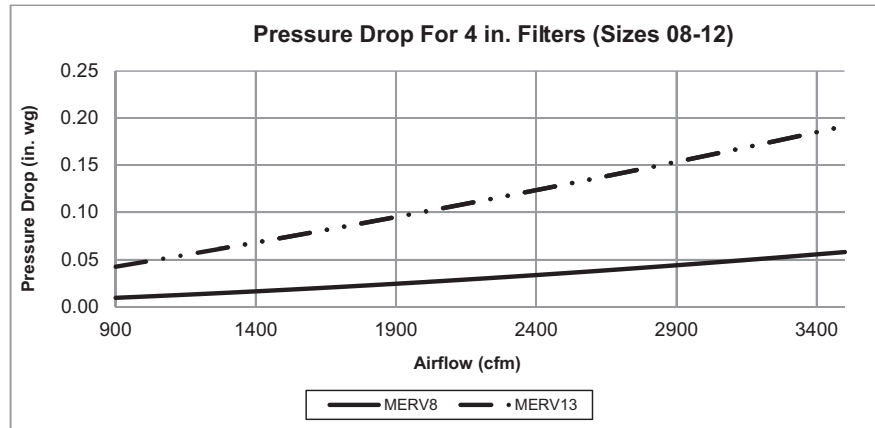

Static Pressure Adders (in. wg) (Factory Options and/or Accessories) (cont)

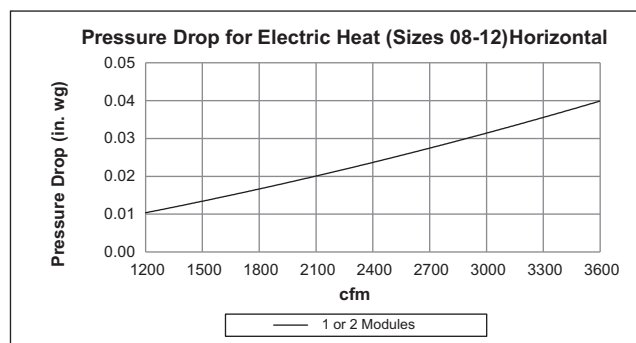
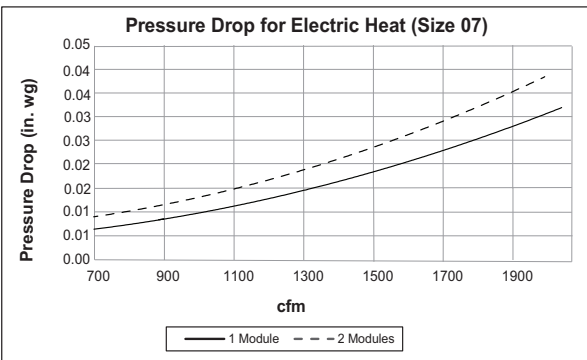
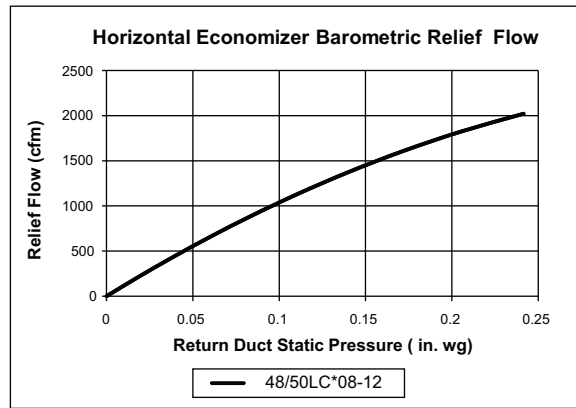
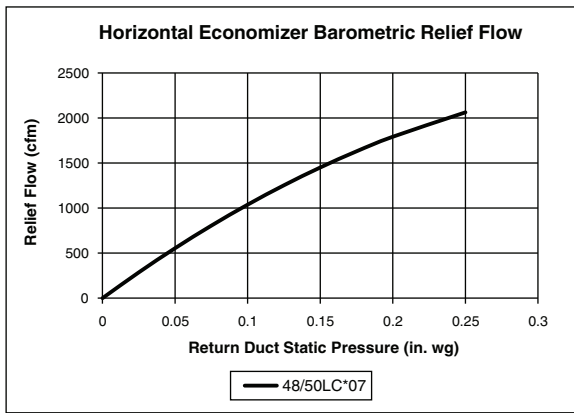
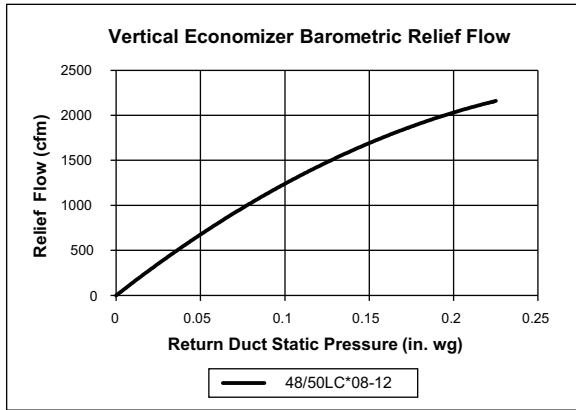
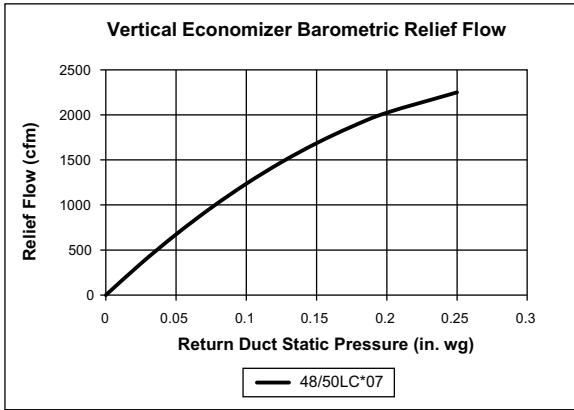

General Fan Performance Notes:

1. Interpolation is permissible. Do not extrapolate.
2. External static pressure is the static pressure difference between the return duct and the supply duct plus the static pressure caused by any FIOPs or accessories.
3. Tabular data accounts for pressure loss due to clean filters, unit casing, and wet coils. Factory options and accessories may add static pressure losses. Selection software is available, through your salesperson, to help you select the best motor combination for your application.
4. The fan performance tables offer motor recommendations. In cases when two motor combinations would work, Carrier recommends the lower horsepower option. Consider future system impacts, such as dirty filters, planned system changes, etc. when selecting fan motor capacity.
5. For information on the electrical properties of Carrier motors, please see the Electrical information section of this book.
6. For more information on the performance limits of Carrier motors, see the application data section of this book.
7. The EPACT (Energy Policy Act) regulates energy requirements for specific types of indoor fan motors. Motors regulated by EPACT include any general purpose, T-frame (three-digit, 143 and larger), single-speed, foot mounted, polyphase, squirrel cage induction motors of NEMA (National Electrical Manufacturers Association) design A and B, manufactured for use in the United States. Ranging from 1 to 200 Hp, these continuous-duty motors operate on 230 and 460 volt, 60 Hz power. If a motor does not fit into these specifications, the motor does not have to be replaced by an EPACT compliant energy-efficient motor. Variable-speed motors are exempt from EPACT compliance requirements.

50LC*H07 — Vertical Supply

| cfm | AVAILABLE EXTERNAL STATIC PRESSURE (in. wg) ^{a,b} | | | | | | | | | |
|------|--|------|------|------|------|------|------|------|------|------|
| | 0.2 | | 0.4 | | 0.6 | | 0.8 | | 1.0 | |
| | rpm | bhp | rpm | bhp | rpm | bhp | rpm | bhp | rpm | bhp |
| 780 | 592 | 0.08 | 769 | 0.17 | 911 | 0.29 | 1034 | 0.42 | 1142 | 0.57 |
| 900 | 622 | 0.09 | 796 | 0.19 | 934 | 0.31 | 1054 | 0.45 | 1161 | 0.60 |
| 1050 | 662 | 0.11 | 830 | 0.22 | 965 | 0.35 | 1082 | 0.49 | 1187 | 0.65 |
| 1200 | 705 | 0.14 | 867 | 0.25 | 999 | 0.38 | 1114 | 0.53 | 1217 | 0.70 |
| 1350 | 751 | 0.16 | 906 | 0.29 | 1035 | 0.43 | 1147 | 0.58 | 1248 | 0.75 |
| 1500 | 799 | 0.20 | 947 | 0.33 | 1073 | 0.47 | 1183 | 0.64 | 1282 | 0.81 |
| 1650 | 849 | 0.23 | 991 | 0.37 | 1112 | 0.53 | 1220 | 0.69 | 1317 | 0.87 |
| 1800 | 901 | 0.28 | 1036 | 0.42 | 1154 | 0.58 | 1259 | 0.76 | 1354 | 0.94 |
| 1950 | 954 | 0.33 | 1083 | 0.48 | 1197 | 0.65 | 1299 | 0.83 | 1393 | 1.02 |
| 2100 | 1009 | 0.39 | 1131 | 0.54 | 1241 | 0.72 | 1341 | 0.91 | 1433 | 1.11 |
| 2250 | 1064 | 0.45 | 1181 | 0.62 | 1287 | 0.80 | 1384 | 0.99 | 1473 | 1.19 |
| 2400 | 1121 | 0.52 | 1232 | 0.69 | 1335 | 0.88 | 1429 | 1.08 | 1516 | 1.29 |
| 2550 | 1178 | 0.60 | 1285 | 0.78 | 1383 | 0.98 | 1474 | 1.18 | 1560 | 1.40 |

| cfm | AVAILABLE EXTERNAL STATIC PRESSURE (in. wg) ^{a,b} | | | | | | | | | |
|------|--|------|------|------|------|------|------|------|------|------|
| | 1.2 | | 1.4 | | 1.6 | | 1.8 | | 2.0 | |
| | rpm | bhp | rpm | bhp | rpm | bhp | rpm | bhp | rpm | bhp |
| 780 | 1242 | 0.73 | 1335 | 0.91 | 1422 | 1.10 | 1504 | 1.30 | 1582 | 1.51 |
| 900 | 1259 | 0.77 | 1350 | 0.95 | 1435 | 1.14 | 1516 | 1.34 | 1593 | 1.55 |
| 1050 | 1283 | 0.81 | 1373 | 1.00 | 1457 | 1.19 | 1536 | 1.40 | 1611 | 1.61 |
| 1200 | 1311 | 0.87 | 1399 | 1.06 | 1481 | 1.25 | 1559 | 1.46 | 1633 | 1.68 |
| 1350 | 1341 | 0.93 | 1427 | 1.12 | 1508 | 1.32 | 1585 | 1.53 | 1658 | 1.76 |
| 1500 | 1373 | 0.99 | 1458 | 1.19 | 1538 | 1.40 | 1613 | 1.61 | 1686 | 1.84 |
| 1650 | 1407 | 1.06 | 1490 | 1.26 | 1569 | 1.48 | 1644 | 1.70 | 1715 | 1.93 |
| 1800 | 1442 | 1.14 | 1525 | 1.35 | 1602 | 1.56 | 1676 | 1.79 | 1746 | 2.02 |
| 1950 | 1479 | 1.22 | 1560 | 1.43 | 1637 | 1.66 | 1709 | 1.89 | 1778 | 2.12 |
| 2100 | 1517 | 1.31 | 1597 | 1.53 | 1672 | 1.76 | 1744 | 1.99 | 1812 | 2.24 |
| 2250 | 1557 | 1.41 | 1635 | 1.63 | 1710 | 1.87 | 1780 | 2.11 | 1848 | 2.36 |
| 2400 | 1598 | 1.51 | 1675 | 1.74 | 1748 | 1.98 | 1817 | 2.23 | 1884 | 2.48 |
| 2550 | 1640 | 1.63 | 1715 | 1.86 | 1787 | 2.10 | 1856 | 2.36 | 1922 | 2.62 |

| cfm | AVAILABLE EXTERNAL STATIC PRESSURE (in. wg) ^{a,b} | | | | | | | | | |
|------|--|------|------|------|------|------|------|------|------|------|
| | 2.2 | | 2.4 | | 2.6 | | 2.8 | | 3.0 | |
| | rpm | bhp | rpm | bhp | rpm | bhp | rpm | bhp | rpm | bhp |
| 780 | 1656 | 1.73 | 1727 | 1.97 | 1796 | 2.21 | 1862 | 2.47 | 1927 | 2.73 |
| 900 | 1666 | 1.78 | 1737 | 2.01 | 1805 | 2.26 | 1870 | 2.51 | 1934 | 2.78 |
| 1050 | 1684 | 1.84 | 1753 | 2.08 | 1820 | 2.33 | 1884 | 2.58 | 1947 | 2.85 |
| 1200 | 1704 | 1.91 | 1773 | 2.15 | 1839 | 2.40 | 1902 | 2.66 | 1964 | 2.92 |
| 1350 | 1728 | 1.99 | 1796 | 2.23 | 1861 | 2.48 | 1923 | 2.74 | 1984 | 3.01 |
| 1500 | 1755 | 2.07 | 1821 | 2.32 | 1885 | 2.57 | 1947 | 2.83 | 2007 | 3.10 |
| 1650 | 1783 | 2.17 | 1849 | 2.42 | 1912 | 2.67 | 1973 | 2.93 | 2032 | 3.21 |
| 1800 | 1813 | 2.26 | 1878 | 2.52 | 1940 | 2.78 | 2001 | 3.05 | 2059 | 3.32 |
| 1950 | 1845 | 2.37 | 1909 | 2.63 | 1971 | 2.89 | 2030 | 3.16 | 2088 | 3.44 |
| 2100 | 1878 | 2.49 | 1941 | 2.75 | 2002 | 3.01 | 2061 | 3.29 | 2119 | 3.57 |
| 2250 | 1912 | 2.61 | 1975 | 2.88 | 2035 | 3.15 | 2094 | 3.43 | 2150 | 3.71 |
| 2400 | 1948 | 2.74 | 2010 | 3.01 | 2069 | 3.29 | 2127 | 3.57 | 2183 | 3.86 |
| 2550 | 1985 | 2.88 | 2046 | 3.16 | 2105 | 3.44 | 2162 | 3.73 | — | — |

NOTE(S):

- a. The above supply fan data is representative of a cooling only unit with clean, standard filters, wet coil, and no economizer. Utilize Carrier packaged RTU builder for fan performance for different configurations.
- b. Fan performance is preliminary and subject to change.

LEGEND

- MED Static (< 2.4 Max BHP)
- HIGH Static (2.4-5 Max BHP)

— Not Available

50LC*H08 — Vertical Supply

| cfm | AVAILABLE EXTERNAL STATIC PRESSURE (in. wg) ^{a,b} | | | | | | | | | |
|------|--|------|------|------|------|------|------|------|------|------|
| | 0.2 | | 0.4 | | 0.6 | | 0.8 | | 1.0 | |
| | rpm | bhp | rpm | bhp | rpm | bhp | rpm | bhp | rpm | bhp |
| 975 | 599 | 0.10 | 769 | 0.20 | 901 | 0.32 | 1014 | 0.46 | 1114 | 0.61 |
| 1125 | 628 | 0.11 | 798 | 0.22 | 929 | 0.35 | 1041 | 0.50 | 1140 | 0.66 |
| 1315 | 666 | 0.13 | 833 | 0.25 | 964 | 0.40 | 1076 | 0.55 | 1174 | 0.71 |
| 1500 | 706 | 0.15 | 869 | 0.29 | 999 | 0.44 | 1110 | 0.60 | 1208 | 0.77 |
| 1690 | 750 | 0.18 | 906 | 0.32 | 1035 | 0.48 | 1146 | 0.65 | 1244 | 0.84 |
| 1875 | 795 | 0.22 | 944 | 0.36 | 1072 | 0.53 | 1181 | 0.71 | 1278 | 0.90 |
| 2065 | 844 | 0.26 | 985 | 0.41 | 1109 | 0.58 | 1218 | 0.77 | 1314 | 0.97 |
| 2250 | 893 | 0.30 | 1026 | 0.46 | 1146 | 0.64 | 1253 | 0.83 | 1350 | 1.04 |
| 2440 | 946 | 0.35 | 1071 | 0.51 | 1186 | 0.70 | 1291 | 0.90 | 1386 | 1.12 |
| 2625 | 998 | 0.41 | 1116 | 0.58 | 1226 | 0.76 | 1328 | 0.97 | 1422 | 1.19 |
| 2815 | 1054 | 0.48 | 1164 | 0.65 | 1270 | 0.84 | 1368 | 1.05 | 1460 | 1.28 |
| 3000 | 1108 | 0.55 | 1213 | 0.73 | 1313 | 0.92 | 1409 | 1.14 | 1498 | 1.37 |
| 3190 | 1164 | 0.63 | 1264 | 0.81 | 1360 | 1.01 | 1452 | 1.23 | 1539 | 1.46 |

| cfm | AVAILABLE EXTERNAL STATIC PRESSURE (in. wg) ^{a,b} | | | | | | | | | |
|------|--|------|------|------|------|------|------|------|------|------|
| | 1.2 | | 1.4 | | 1.6 | | 1.8 | | 2.0 | |
| | rpm | bhp | rpm | bhp | rpm | bhp | rpm | bhp | rpm | bhp |
| 975 | 1206 | 0.78 | 1291 | 0.95 | 1371 | 1.14 | 1447 | 1.34 | 1520 | 1.55 |
| 1125 | 1230 | 0.82 | 1314 | 1.00 | 1392 | 1.19 | 1467 | 1.40 | 1538 | 1.61 |
| 1315 | 1263 | 0.89 | 1345 | 1.07 | 1423 | 1.27 | 1496 | 1.48 | 1565 | 1.69 |
| 1500 | 1297 | 0.96 | 1378 | 1.15 | 1455 | 1.35 | 1527 | 1.56 | 1595 | 1.78 |
| 1690 | 1332 | 1.03 | 1413 | 1.23 | 1489 | 1.43 | 1561 | 1.65 | 1628 | 1.88 |
| 1875 | 1367 | 1.10 | 1448 | 1.31 | 1523 | 1.52 | 1594 | 1.74 | 1662 | 1.98 |
| 2065 | 1402 | 1.18 | 1483 | 1.39 | 1559 | 1.62 | 1630 | 1.85 | 1697 | 2.08 |
| 2250 | 1437 | 1.25 | 1518 | 1.48 | 1594 | 1.71 | 1664 | 1.95 | 1732 | 2.20 |
| 2440 | 1473 | 1.34 | 1554 | 1.57 | 1629 | 1.81 | 1700 | 2.06 | 1767 | 2.31 |
| 2625 | 1509 | 1.43 | 1589 | 1.67 | 1664 | 1.91 | 1735 | 2.17 | 1802 | 2.43 |
| 2815 | 1546 | 1.52 | 1626 | 1.77 | 1700 | 2.02 | 1771 | 2.28 | 1838 | 2.55 |
| 3000 | 1583 | 1.61 | 1661 | 1.86 | 1736 | 2.13 | 1806 | 2.40 | 1873 | 2.67 |
| 3190 | 1621 | 1.71 | 1699 | 1.97 | 1773 | 2.24 | 1842 | 2.51 | 1909 | 2.80 |

| cfm | AVAILABLE EXTERNAL STATIC PRESSURE (in. wg) ^{a,b} | | | | | | | | | |
|------|--|------|------|------|------|------|------|------|------|------|
| | 2.2 | | 2.4 | | 2.6 | | 2.8 | | 3.0 | |
| | rpm | bhp | rpm | bhp | rpm | bhp | rpm | bhp | rpm | bhp |
| 975 | 1589 | 1.77 | 1656 | 2.01 | 1721 | 2.26 | 1783 | 2.51 | 1844 | 2.77 |
| 1125 | 1606 | 1.83 | 1671 | 2.07 | 1734 | 2.31 | 1795 | 2.56 | 1855 | 2.83 |
| 1315 | 1632 | 1.92 | 1696 | 2.15 | 1758 | 2.40 | 1817 | 2.65 | 1875 | 2.91 |
| 1500 | 1661 | 2.01 | 1724 | 2.25 | 1785 | 2.49 | 1843 | 2.74 | 1900 | 3.01 |
| 1690 | 1693 | 2.11 | 1755 | 2.35 | 1815 | 2.60 | 1873 | 2.86 | 1929 | 3.12 |
| 1875 | 1726 | 2.21 | 1788 | 2.46 | 1847 | 2.71 | 1905 | 2.98 | 1960 | 3.24 |
| 2065 | 1761 | 2.33 | 1822 | 2.58 | 1881 | 2.84 | 1938 | 3.11 | 1993 | 3.38 |
| 2250 | 1795 | 2.44 | 1857 | 2.71 | 1915 | 2.97 | 1972 | 3.24 | 2027 | 3.52 |
| 2440 | 1831 | 2.57 | 1892 | 2.84 | 1951 | 3.11 | 2007 | 3.39 | 2061 | 3.67 |
| 2625 | 1866 | 2.70 | 1927 | 2.97 | 1985 | 3.25 | 2041 | 3.53 | 2096 | 3.82 |
| 2815 | 1901 | 2.82 | 1962 | 3.10 | 2021 | 3.39 | 2077 | 3.68 | 2131 | 3.98 |
| 3000 | 1936 | 2.95 | 1997 | 3.24 | 2056 | 3.54 | 2112 | 3.83 | 2166 | 4.13 |
| 3190 | 1972 | 3.08 | 2033 | 3.38 | 2091 | 3.67 | 2147 | 3.98 | — | — |

NOTE(S):

- a. The above supply fan data is representative of a cooling only unit with clean, standard filters, wet coil, and no economizer. Utilize Carrier packaged RTU builder for fan performance for different configurations.
- b. Fan performance is preliminary and subject to change.

LEGEND

- MED Static (< 2.4 Max BHP)
- HIGH Static (2.4-5 Max BHP)

— Not Available

50LC*H12 — Vertical Supply

| cfm | AVAILABLE EXTERNAL STATIC PRESSURE (in. wg) ^{a,b} | | | | | | | | | |
|------|--|------|------|------|------|------|------|------|------|------|
| | 0.2 | | 0.4 | | 0.6 | | 0.8 | | 1.0 | |
| | rpm | bhp | rpm | bhp | rpm | bhp | rpm | bhp | rpm | bhp |
| 1300 | 663 | 0.13 | 831 | 0.25 | 962 | 0.39 | 1073 | 0.55 | 1170 | 0.71 |
| 1500 | 706 | 0.15 | 869 | 0.29 | 999 | 0.44 | 1110 | 0.60 | 1208 | 0.77 |
| 1750 | 764 | 0.19 | 918 | 0.34 | 1047 | 0.50 | 1157 | 0.67 | 1255 | 0.86 |
| 2000 | 826 | 0.24 | 970 | 0.39 | 1095 | 0.56 | 1205 | 0.75 | 1302 | 0.94 |
| 2250 | 893 | 0.30 | 1026 | 0.46 | 1146 | 0.64 | 1253 | 0.83 | 1349 | 1.04 |
| 2500 | 962 | 0.37 | 1085 | 0.53 | 1199 | 0.72 | 1303 | 0.92 | 1397 | 1.14 |
| 2750 | 1034 | 0.46 | 1147 | 0.62 | 1254 | 0.81 | 1354 | 1.02 | 1447 | 1.25 |
| 3000 | 1108 | 0.55 | 1212 | 0.72 | 1313 | 0.92 | 1408 | 1.14 | 1498 | 1.37 |
| 3250 | 1182 | 0.66 | 1280 | 0.84 | 1374 | 1.04 | 1465 | 1.26 | 1551 | 1.49 |
| 3500 | 1258 | 0.78 | 1350 | 0.97 | 1438 | 1.17 | 1524 | 1.39 | 1607 | 1.63 |
| 3750 | 1335 | 0.91 | 1421 | 1.10 | 1504 | 1.30 | 1586 | 1.53 | 1665 | 1.77 |
| 4000 | 1413 | 1.05 | 1493 | 1.24 | 1572 | 1.44 | 1650 | 1.67 | 1725 | 1.91 |
| 4250 | 1491 | 1.19 | 1567 | 1.38 | 1642 | 1.59 | 1715 | 1.81 | 1787 | 2.05 |

| cfm | AVAILABLE EXTERNAL STATIC PRESSURE (in. wg) ^{a,b} | | | | | | | | | |
|------|--|------|------|------|------|------|------|------|------|------|
| | 1.2 | | 1.4 | | 1.6 | | 1.8 | | 2.0 | |
| | rpm | bhp | rpm | bhp | rpm | bhp | rpm | bhp | rpm | bhp |
| 1300 | 1260 | 0.88 | 1342 | 1.07 | 1420 | 1.26 | 1493 | 1.47 | 1563 | 1.68 |
| 1500 | 1297 | 0.96 | 1378 | 1.15 | 1455 | 1.35 | 1527 | 1.56 | 1595 | 1.78 |
| 1750 | 1343 | 1.05 | 1424 | 1.25 | 1500 | 1.46 | 1571 | 1.68 | 1639 | 1.91 |
| 2000 | 1390 | 1.15 | 1471 | 1.36 | 1546 | 1.58 | 1617 | 1.81 | 1685 | 2.05 |
| 2250 | 1437 | 1.25 | 1518 | 1.48 | 1593 | 1.71 | 1664 | 1.95 | 1731 | 2.19 |
| 2500 | 1484 | 1.36 | 1565 | 1.60 | 1640 | 1.84 | 1711 | 2.09 | 1778 | 2.35 |
| 2750 | 1533 | 1.49 | 1613 | 1.73 | 1688 | 1.98 | 1758 | 2.24 | 1825 | 2.51 |
| 3000 | 1582 | 1.61 | 1661 | 1.86 | 1736 | 2.13 | 1806 | 2.40 | 1873 | 2.67 |
| 3250 | 1633 | 1.74 | 1711 | 2.00 | 1784 | 2.27 | 1854 | 2.55 | 1920 | 2.83 |
| 3500 | 1686 | 1.88 | 1762 | 2.15 | 1834 | 2.42 | 1903 | 2.70 | 1968 | 2.99 |
| 3750 | 1741 | 2.02 | 1814 | 2.28 | 1885 | 2.56 | 1952 | 2.85 | 2017 | 3.14 |
| 4000 | 1798 | 2.16 | 1869 | 2.43 | 1938 | 2.70 | 2004 | 2.99 | 2068 | 3.29 |
| 4250 | 1857 | 2.30 | 1926 | 2.56 | 1992 | 2.84 | 2057 | 3.12 | 2119 | 3.41 |

| cfm | AVAILABLE EXTERNAL STATIC PRESSURE (in. wg) ^{a,b} | | | | | | | | | |
|------|--|------|------|------|------|------|------|------|------|------|
| | 2.2 | | 2.4 | | 2.6 | | 2.8 | | 3.0 | |
| | rpm | bhp | rpm | bhp | rpm | bhp | rpm | bhp | rpm | bhp |
| 1300 | 1630 | 1.91 | 1694 | 2.15 | 1756 | 2.39 | 1815 | 2.64 | 1873 | 2.90 |
| 1500 | 1661 | 2.01 | 1724 | 2.25 | 1785 | 2.49 | 1843 | 2.74 | 1900 | 3.01 |
| 1750 | 1704 | 2.14 | 1766 | 2.39 | 1826 | 2.64 | 1883 | 2.89 | 1939 | 3.16 |
| 2000 | 1749 | 2.29 | 1810 | 2.54 | 1869 | 2.79 | 1926 | 3.06 | 1982 | 3.33 |
| 2250 | 1795 | 2.44 | 1856 | 2.70 | 1915 | 2.97 | 1972 | 3.24 | 2026 | 3.52 |
| 2500 | 1842 | 2.61 | 1903 | 2.88 | 1962 | 3.15 | 2018 | 3.43 | 2072 | 3.71 |
| 2750 | 1889 | 2.78 | 1950 | 3.06 | 2008 | 3.34 | 2065 | 3.63 | 2119 | 3.92 |
| 3000 | 1936 | 2.95 | 1997 | 3.24 | 2055 | 3.53 | 2112 | 3.83 | 2166 | 4.13 |
| 3250 | 1983 | 3.12 | 2044 | 3.42 | 2102 | 3.72 | 2159 | 4.03 | — | — |
| 3500 | 2031 | 3.29 | 2092 | 3.59 | 2150 | 3.90 | — | — | — | — |
| 3750 | 2080 | 3.44 | 2140 | 3.75 | 2197 | 4.06 | — | — | — | — |
| 4000 | 2129 | 3.59 | 2188 | 3.89 | — | — | — | — | — | — |
| 4250 | 2179 | 3.71 | — | — | — | — | — | — | — | — |

NOTE(S):

- a. The above supply fan data is representative of a cooling only unit with clean, standard filters, wet coil, and no economizer. Utilize Carrier packaged RTU builder for fan performance for different configurations.
- b. Fan performance is preliminary and subject to change.

LEGEND

- MED Static (< 2.4 Max BHP)
- HIGH Static (2.4-5 Max BHP)
- Not Available

Legend and notes for pages 50 to 52.

LEGEND

- C/O** — Convenience Outlet
IFM — Indoor Fan Motor
OFM — Outdoor Fan Motors (Condenser Fans)

NOTES:

1. Electrical data is preliminary and subject to change. See Carrier Packaged RTU builder for production electrical information and unit MCA/MOCP values.
2. For 208/230-v units, where one value is shown it is the same for either 208-v or 230-v.
3. Unbalanced 3-Phase Supply Voltage
 Never operate a motor where a phase imbalance in supply voltage is greater than 2%. Use the following formula to determine the percentage of voltage imbalance.

$$\% \text{ Voltage Imbalance} = 100 \times \frac{\text{max voltage deviation from average voltage}}{\text{average voltage}}$$

Example: Supply voltage is 230-3-60

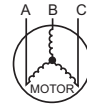

AB = 224 v
 BC = 231 v
 AC = 226 v

$$\text{Average Voltage} = \frac{(224 + 231 + 226)}{3} = \frac{681}{3} = 227$$

Determine maximum deviation from average voltage.

(AB) 227-224 = 3 v

(BC) 231-227 = 4 v

(AC) 227-226 = 1 v

Maximum deviation is 4 v.

Determine percent of voltage imbalance.

$$\% \text{ Voltage Imbalance} = 100 \times \frac{4}{227} = 1.78\%$$

This amount of phase imbalance is satisfactory as it is below the maximum allowable 2%.

IMPORTANT: If the supply voltage phase imbalance is more than 2%, contact your local electric utility company immediately.

48LC*H 07-12 Electrical Data Table^{a,b}

| UNIT SIZE | VOLTAGE | IFM TYPE | VOLTAGE RANGE | | COMPRESSOR | | | | OFM | | COMBUSTION FAN MOTOR | IFM | POWER SUPPLY | | DISCONNECT SIZE | | |
|-----------|----------|----------|---------------|-----|------------|------|-------|------|-----|----------|----------------------|------|--------------|--------------|-----------------|-----|-----|
| | | | | | No. 1 | | No. 2 | | | | | | | | | | |
| | | | Min | Max | RLA | LRA | RLA | LRA | Qty | FLA (ea) | FLA | FLA | MCA | FUSE or HACR | FLA | LRA | |
| 48LC*H07 | 208-3-60 | MED | 187 | 253 | 8.3 | 58 | 13.2 | 88 | 2 | | 0.48 | 6.4 | 35 | 45 | 36 | 156 | |
| | | HIGH | | | | | | | | | 0.48 | 12.7 | 42 | 50 | 43 | 163 | |
| | 230-3-60 | MED | 414 | 506 | 5.1 | 28 | 6.0 | 44 | | | 0.48 | 6.4 | 35 | 45 | 36 | 156 | |
| | | HIGH | | | | | | | | | 0.48 | 12.7 | 42 | 50 | 43 | 163 | |
| | 460-3-60 | MED | 518 | 633 | 3.3 | 24 | 4.2 | 30 | | | 0.25 | 3.0 | 20 | 25 | 20 | 79 | |
| | | HIGH | | | | | | | | | 0.25 | 5.8 | 22 | 25 | 24 | 82 | |
| | 48LC*H08 | 208-3-60 | MED | 187 | 253 | 13.2 | 88 | 13.7 | 83 | 3 | 1.8 | 0.48 | 6.4 | 43 | 50 | 45 | 183 |
| | | | HIGH | | | | | | | | | 0.48 | 12.7 | 49 | 60 | 52 | 190 |
| | | 230-3-60 | MED | 414 | 506 | 6.0 | 44 | 6.2 | 41 | | | 0.48 | 6.4 | 43 | 50 | 45 | 183 |
| | | | HIGH | | | | | | | | | 0.48 | 12.7 | 49 | 60 | 52 | 190 |
| 460-3-60 | | MED | 518 | 633 | 4.2 | 30 | 4.8 | 33 | | | 0.25 | 3.0 | 23 | 25 | 24 | 94 | |
| | | HIGH | | | | | | | | | 0.25 | 5.8 | 25 | 30 | 27 | 97 | |
| 48LC*H12 | | 208-3-60 | MED | 187 | 253 | 13.1 | 83 | 19.6 | 136 | 3 | | 0.48 | 6.4 | 50 | 60 | 51 | 231 |
| | | | HIGH | | | | | | | | | 0.48 | 12.7 | 56 | 70 | 58 | 238 |
| | | 230-3-60 | MED | 414 | 506 | 6.1 | 41 | 8.2 | 66 | | | 0.48 | 6.4 | 50 | 60 | 51 | 231 |
| | | | HIGH | | | | | | | | | 0.48 | 12.7 | 56 | 70 | 58 | 238 |
| | 460-3-60 | MED | 518 | 633 | 4.4 | 33 | 6.6 | 55 | | | 0.25 | 3.0 | 25 | 30 | 26 | 116 | |
| | | HIGH | | | | | | | | | 0.25 | 5.8 | 28 | 30 | 29 | 119 | |
| | 575-3-60 | MED | | | | | | | | | 0.24 | 2.5 | 21 | 25 | 22 | 97 | |
| | | HIGH | | | | | | | | | 0.24 | 4.1 | 23 | 25 | 24 | 98 | |

NOTE(S):

- a. The electrical data is representative of a typical unit without factory wired convenience outlet, accessory power exhaust, or HACR breaker. Consult Carrier Packaged RTU Builder for electrical data for different configurations.
- b. The electrical data provided is preliminary and is subject to change.

50LC*H 07-12 Electrical Data Table^{a,b}

| UNIT | VOLTAGE | IFM | VOLTAGE RANGE | | COMPRESSOR | | | | OFM | | IFM | ELECTRIC HEAT | | | POWER SUPPLY | | DISCONNECT SIZE | | | | | | | | |
|----------|----------|------|---------------|------|------------|-----|-------|-----|-----|----------|------|---------------|----------|------|--------------|-----|-----------------|-----|------|------|------|----|----|----|-----|
| | | | Min | Max | No. 1 | | No. 2 | | Qty | FLA (ea) | | FLA | Part No. | FLA | Appl. kW | MCA | Fuse or HACR | FLA | LRA | | | | | | |
| | | | | | RLA | LRA | RLA | LRA | | | | | | | | | | | | | | | | | |
| 50LC*H07 | 208-3-60 | MED | 187 | 253 | 8.3 | 58 | 13.2 | 88 | 2 | 1.8 | 6.4 | NONE | 0 | 0 | 35 | 45 | 36 | 156 | | | | | | | |
| | | | | | | | | | | | | 411A | 21.7 | 7.8 | 36 | 45 | 36 | 156 | | | | | | | |
| | | 412A | | | | | | | | | 33.4 | 12 | 50 | 50 | 46 | 156 | | | | | | | | | |
| | | HIGH | | | | | | | | | NONE | 0 | 0 | 42 | 50 | 43 | 163 | | | | | | | | |
| | 411A | | | | | | | | | | 21.7 | 7.8 | 43 | 50 | 43 | 163 | | | | | | | | | |
| | 230-3-60 | MED | | | | | | | | | 411A | 21.7 | 7.8 | 43 | 50 | 43 | 163 | 6.4 | NONE | 0 | 0 | 35 | 45 | 36 | 156 |
| | | | | | | | | | | | | | | | | | | | 411A | 25 | 9.6 | 40 | 45 | 36 | 156 |
| | | 412A | | | | | | | | | 38.5 | 14.7 | 57 | 60 | 52 | 156 | | | | | | | | | |
| | | HIGH | NONE | 0 | 0 | 42 | 50 | 43 | | | 163 | | | | | | | | | | | | | | |
| | 411A | | 25 | 9.6 | 48 | 50 | 43 | 163 | | | | | | | | | | | | | | | | | |
| | 460-3-60 | MED | 411A | 25 | 9.6 | 48 | 50 | 43 | | | 163 | 12.7 | 412A | 38.5 | 14.7 | 64 | 70 | 59 | 163 | | | | | | |
| | | | | | | | | | | | | | NONE | 0 | 0 | 20 | 25 | 20 | 79 | | | | | | |
| HIGH | | 419A | 13.8 | 10.6 | 21 | 25 | 20 | 79 | | | | | | | | | | | | | | | | | |
| | | 421A | 30.1 | 23 | 42 | 45 | 38 | 79 | | | | | | | | | | | | | | | | | |
| 575-3-60 | MED | 419A | 13.8 | 10.6 | 25 | 25 | 24 | 82 | 5.8 | NONE | 0 | 0 | 22 | 25 | 24 | 82 | | | | | | | | | |
| | | | | | | | | | | 419A | 13.8 | 10.6 | 25 | 25 | 24 | 82 | | | | | | | | | |
| | HIGH | 421A | 30.1 | 23 | 45 | 45 | 41 | 82 | | | | | | | | | | | | | | | | | |
| | | NONE | TBD | 0 | 0 | 15 | 20 | 16 | 61 | | | | | | | | | | | | | | | | |
| 50LC*H08 | 208-3-60 | MED | 187 | 253 | 13.2 | 88 | 13.7 | 83 | 3 | 1.8 | 6.4 | NONE | 0 | 0 | 43 | 50 | 45 | 183 | | | | | | | |
| | | | | | | | | | | | | 412A | 33.4 | 12 | 50 | 50 | 46 | 183 | | | | | | | |
| | | 414A | | | | | | | | | 52.1 | 18.8 | 74 | 80 | 67 | 183 | | | | | | | | | |
| | | HIGH | | | | | | | | | NONE | 0 | 0 | 49 | 60 | 52 | 190 | | | | | | | | |
| | 412A | | | | | | | | | | 33.4 | 12 | 58 | 60 | 53 | 190 | | | | | | | | | |
| | 230-3-60 | MED | | | | | | | | | 414A | 52.1 | 18.8 | 81 | 90 | 75 | 190 | 6.4 | NONE | 0 | 0 | 43 | 50 | 45 | 183 |
| | | | | | | | | | | | | | | | | | | | 412A | 38.5 | 14.7 | 57 | 60 | 52 | 183 |
| | | HIGH | | | | | | | | | 414A | 60.1 | 23 | 84 | 90 | 76 | 183 | | | | | | | | |
| | | | NONE | 0 | 0 | 49 | 60 | 52 | | | 190 | | | | | | | | | | | | | | |
| | 460-3-60 | MED | 412A | 38.5 | 14.7 | 64 | 70 | 59 | | | 190 | 12.7 | 412A | 38.5 | 14.7 | 64 | 70 | 59 | 190 | | | | | | |
| | | | | | | | | | | | | | 414A | 60.1 | 23 | 91 | 100 | 84 | 190 | | | | | | |
| | | HIGH | NONE | 0 | 0 | 23 | 25 | 24 | | | 94 | | | | | | | | | | | | | | |
| 420A | | | 18 | 13.8 | 27 | 30 | 24 | 94 | | | | | | | | | | | | | | | | | |
| 575-3-60 | MED | 422A | 39.7 | 30.3 | 54 | 60 | 49 | 97 | 5.8 | NONE | 0 | 0 | 25 | 30 | 27 | 97 | | | | | | | | | |
| | | | | | | | | | | 420A | 18 | 13.8 | 30 | 30 | 27 | 97 | | | | | | | | | |
| | HIGH | 422A | 39.7 | 30.3 | 57 | 60 | 52 | 97 | | | | | | | | | | | | | | | | | |
| | | NONE | TBD | 0 | 0 | 19 | 20 | 19 | 72 | | | | | | | | | | | | | | | | |
| 575-3-60 | MED | TBD | 0 | 0 | 19 | 20 | 19 | 72 | 2.5 | NONE | TBD | 0 | 0 | 19 | 20 | 19 | 72 | | | | | | | | |
| | | | | | | | | | | TBD | 0 | 0 | 19 | 20 | 19 | 72 | | | | | | | | | |
| | HIGH | NONE | TBD | 0 | 0 | 20 | 25 | 21 | 73 | | | | | | | | | | | | | | | | |
| | | TBD | 0 | 0 | 20 | 25 | 21 | 73 | | | | | | | | | | | | | | | | | |

NOTE(S):

- a. The electrical data is representative of a typical unit without factory wired convenience outlet, accessory power exhaust, or HACR breaker. Consult Carrier Packaged RTU Builder for electrical data for different configurations.
- b. The electrical data provided is preliminary and is subject to change.

Electrical data (cont)



50LC*H 07-12 Electrical Data Table^{a,b}

| UNIT | VOLTAGE | IFM | VOLTAGE RANGE | | COMPRESSOR | | | | OFM | | IFM | ELECTRIC HEAT | | | POWER SUPPLY | | DISCONNECT SIZE | | | | | | | | |
|----------|----------|------|---------------|-----|------------|-----|-------|-----|-----|----------|-----|---------------|----------|------|--------------|------|-----------------|------|------|------|------|-----|----|-----|-----|
| | | | Min | Max | No. 1 | | No. 2 | | Qty | FLA (ea) | | FLA | Part No. | FLA | Appl. kW | MCA | Fuse or HACR | FLA | LRA | | | | | | |
| | | | | | RLA | LRA | RLA | LRA | | | | | | | | | | | | | | | | | |
| 50LC*H12 | 208-3-60 | MED | 187 | 253 | 13.1 | 83 | 19.6 | 136 | 3 | 1.8 | 6.4 | NONE | 0 | 0 | 50 | 60 | 51 | 231 | | | | | | | |
| | | | | | | | | | | | | 412A | 33.4 | 12 | 50 | 60 | 51 | 231 | | | | | | | |
| | | | | | | | | | | | | 414A | 52.1 | 18.8 | 74 | 80 | 67 | 231 | | | | | | | |
| | | HIGH | | | | | | | | | | 187 | 253 | 13.1 | 83 | 19.6 | 136 | 12.7 | NONE | 0 | 0 | 56 | 70 | 58 | 238 |
| | | | | | | | | | | | | | | | | | | | 412A | 33.4 | 12 | 58 | 70 | 58 | 238 |
| | | | | | | | | | | | | | | | | | | | 414A | 52.1 | 18.8 | 81 | 90 | 75 | 238 |
| | 230-3-60 | MED | 187 | 253 | 13.1 | 83 | 19.6 | 136 | | | 6.4 | | | | | | | NONE | 0 | 0 | 50 | 60 | 51 | 231 | |
| | | | | | | | | | | | | | | | | | | 412A | 38.5 | 14.7 | 57 | 60 | 52 | 231 | |
| | | | | | | | | | | | | | | | | | | 414A | 60.1 | 23 | 84 | 90 | 76 | 231 | |
| | | HIGH | | | | | | | | | 187 | 253 | 13.1 | 83 | 19.6 | 136 | 12.7 | NONE | 0 | 0 | 56 | 70 | 58 | 238 | |
| | | | | | | | | | | | | | | | | | | 412A | 38.5 | 14.7 | 64 | 70 | 59 | 238 | |
| | | | | | | | | | | | | | | | | | | 414A | 60.1 | 23 | 91 | 100 | 84 | 238 | |
| | 460-3-60 | MED | 414 | 506 | 6.1 | 41 | 8.2 | 66 | | | | | | | | | 3 | NONE | 0 | 0 | 25 | 30 | 26 | 116 | |
| | | | | | | | | | | | | | | | | | | 420A | 18 | 13.8 | 27 | 30 | 26 | 116 | |
| | | | | | | | | | | | | | | | | | | 422A | 39.7 | 30.3 | 54 | 60 | 49 | 116 | |
| | | HIGH | | | | | | | | | 414 | 506 | 6.1 | 41 | 8.2 | 66 | 5.8 | NONE | 0 | 0 | 28 | 30 | 29 | 119 | |
| | | | | | | | | | | | | | | | | | | 420A | 18 | 13.8 | 30 | 30 | 29 | 119 | |
| | | | | | | | | | | | | | | | | | | 422A | 39.7 | 30.3 | 57 | 60 | 52 | 119 | |
| | 575-3-60 | MED | 518 | 633 | 4.4 | 33 | 6.6 | 55 | | | | | | | | | 2.5 | NONE | 0 | 0 | 21 | 25 | 22 | 97 | |
| | | | | | | | | | | | | | | | | | | TBD | | | | | | | |
| | | | | | | | | | | | | | | | | | | TBD | | | | | | | |
| MED | | 518 | | | | | | | 633 | 4.4 | 33 | 6.6 | 55 | 4.1 | NONE | 0 | 0 | 23 | 25 | 24 | 98 | | | | |
| | | | | | | | | | | | | | | | TBD | | | | | | | | | | |
| | | | | | | | | | | | | | | | TBD | | | | | | | | | | |

NOTE(S):

- a. The electrical data is representative of a typical unit without factory wired convenience outlet, accessory power exhaust, or HACR breaker. Consult Carrier Packaged RTU Builder for electrical data for different configurations.
- b. The electrical data provided is preliminary and is subject to change.

Typical Power Wiring Diagram (50LC*H07)

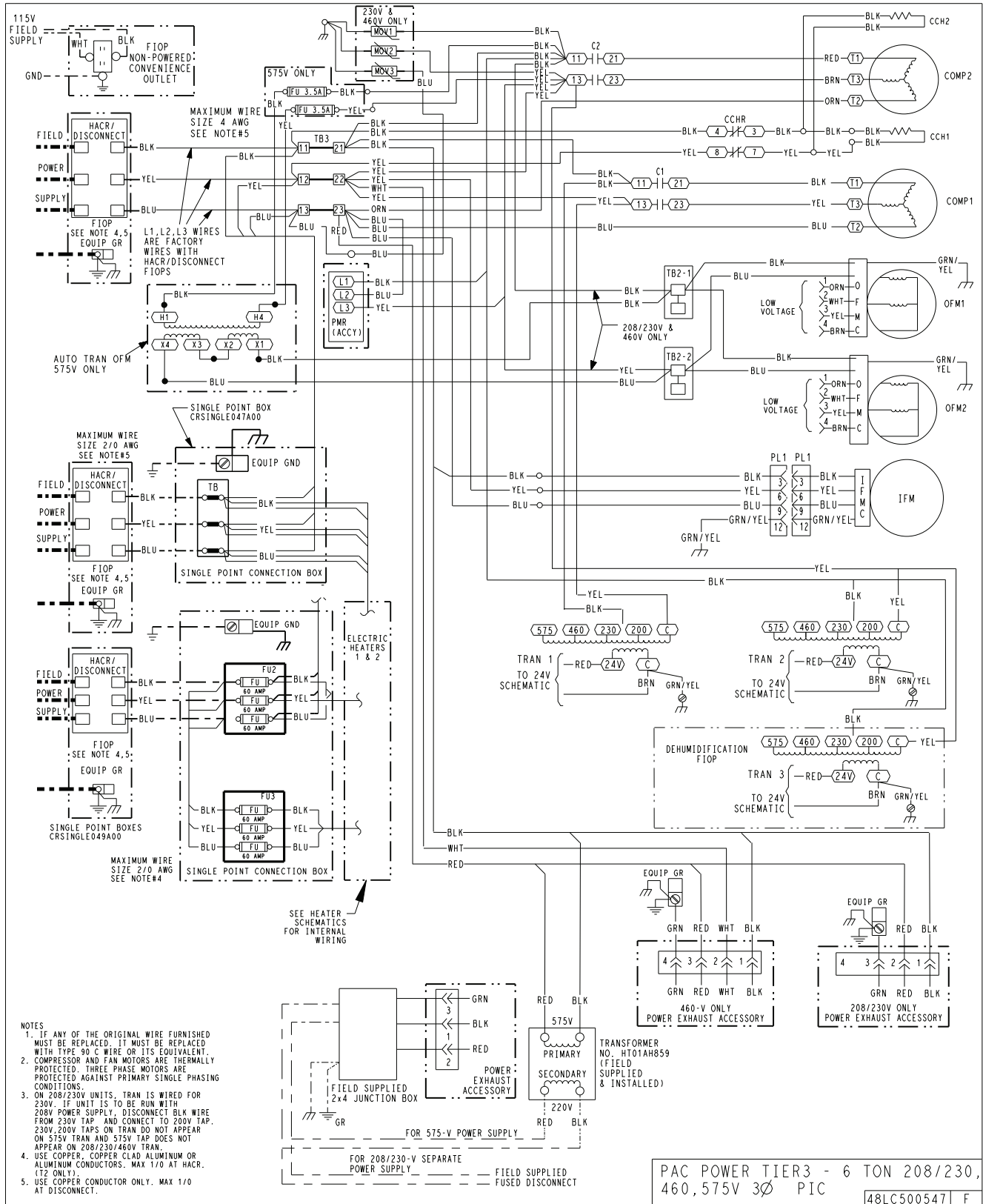

NOTE: Power wiring diagram is preliminary and subject to change.

SmartVu™ Control Wiring Diagram (Size 07)

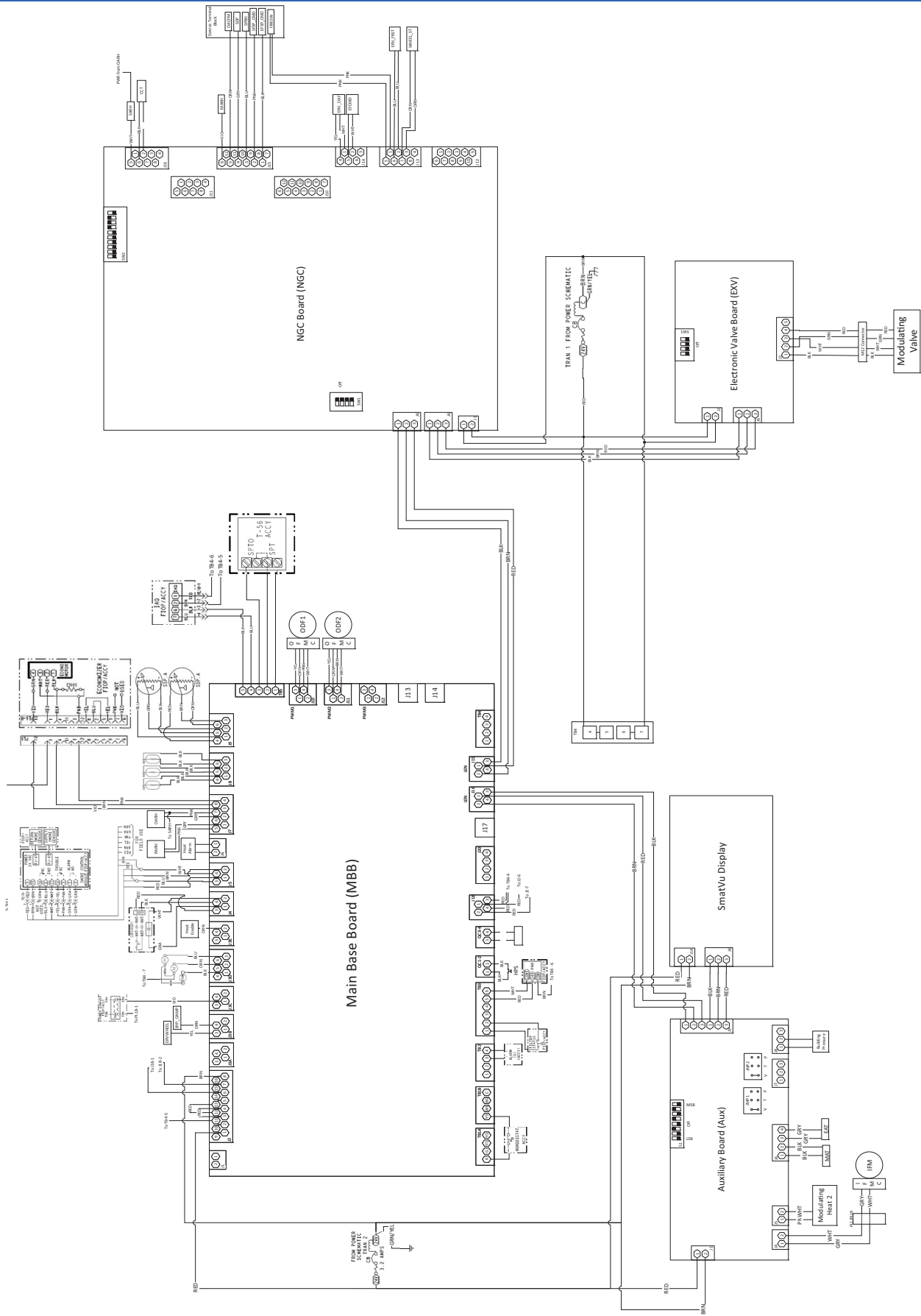

NOTE: Control wiring diagram is preliminary and subject to change.

SmartVu™ Control Wiring Diagram (Size 08-12)

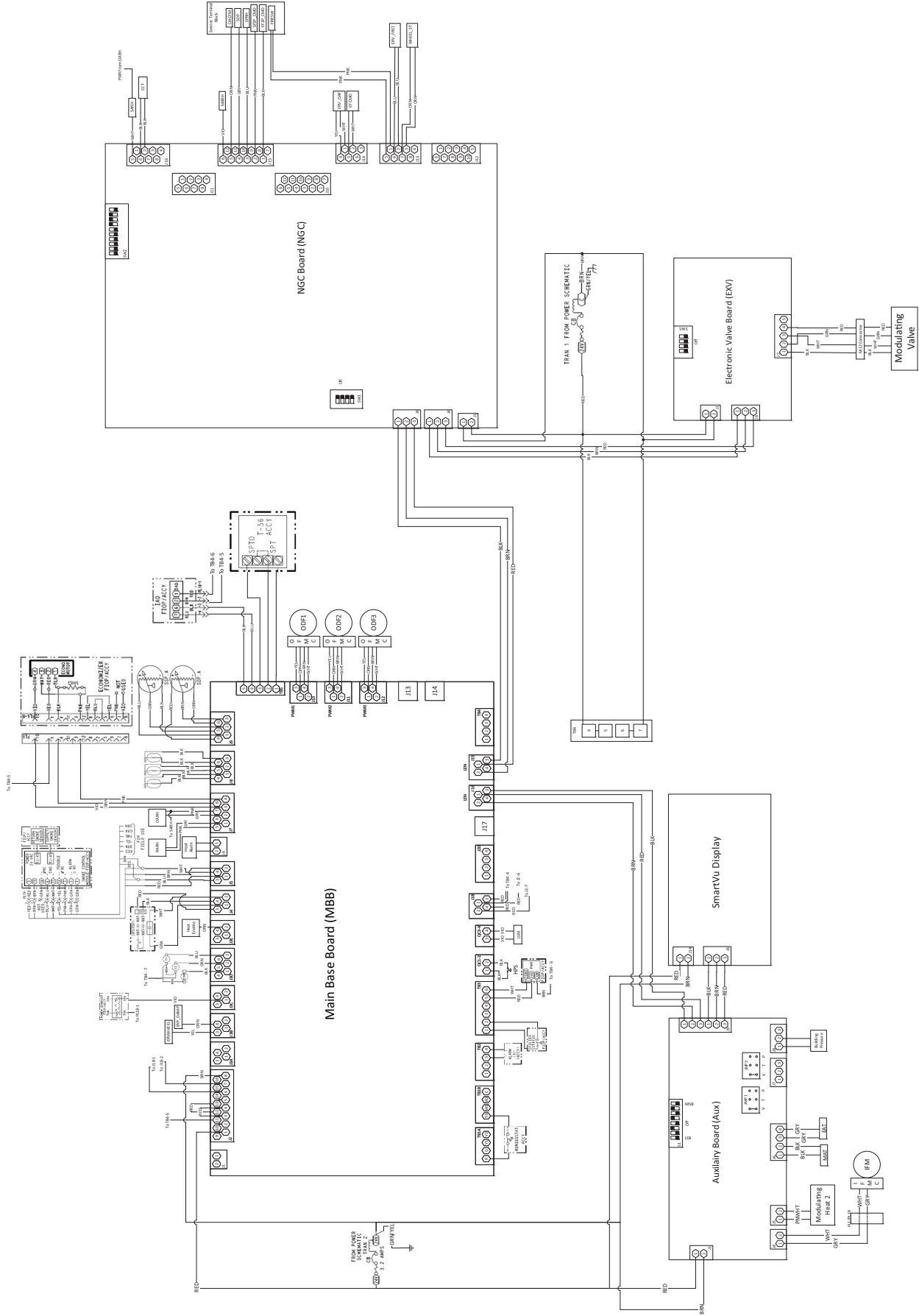

NOTE :Control wiring diagram is preliminary and subject to change.

General

The 48/50LC*H operating sequence will vary based on the unit and control configurations.

The SmartVu™ controls govern most aspects of the unit operation and will operate to the effective supply air temperature, including the supply and exhaust fan, outdoor air damper, the cooling and dehumidification system; including compressors, condenser fans, and hot gas reheat system, and the heating system.

The SmartVu controls provide supply air temperature based control to satisfy a cooling or heating demand and cooling coil temperature based control to satisfy a dehumidification demand.

Below is a summary of key configurations and the resulting operation. See the 48/50LC*H controls manual for further details. See Recommended Control Configuration By Applications Type Table on page 62 for a quick reference of recommended control configurations.

Control settings and operation

Occupancy

The unit occupancy control determines if the unit is in the occupied or unoccupied period, which affects how the unit behaves and what setpoints are active. The occupied period is intended as a normal unit operation. The unoccupied period is intended as a setback operation or disabled operation. The following occupancy sources are available:

Occupancy Controls

| NAME | DESCRIPTION |
|-------------------------|--|
| Occupancy Switch | An input switch status determines occupancy. |
| Bas Occupancy | A network input determines occupancy. |
| Unit Schedule | The local unit schedule (in SmartVu) determines occupancy. |

Simultaneous use of multiple occupancy sources is allowed. SmartVu uses the higher priority occupancy source when sources conflict. The level of priority (highest first) and description of the source types are as follows:

Occupancy switch

The unit will determine occupancy based on a hardwired occupancy input. When the input is open, the unit is in the unoccupied period. When the input is closed, the unit is in the occupied period. A field provided and installed occupancy relay or Toshiba-Carrier or, Carrier VRF ERV interface is required.

BAS occupancy

The unit will monitor the network occupancy command point to determine occupancy. It will require a field provided and installed BAS system.

Unit Schedule

The unit will determine occupancy based on the current time and date and the occupancy schedule configured in the unit controller. The local schedule allows a single occupancy start time and stop time, selectable by day and in hour/minute increments. The schedule function also allows for 24/7 scheduling.

Supply fan operation

These configurations determine when the supply fan operates based on the occupancy period. The available

operation configuration may be limited by the supply fan control method that is selected. The following configurations are available:

Occupied Supply Fan Operation

| NAME | DESCRIPTION |
|-------------------|---|
| Continuous | The supply fan operates continuously during the occupied period. |
| Demand | The supply fan only operates when there is a call for cooling, heating, dehumidification, or <i>Venting</i> during the occupied period. |

The sequence of operation is as follows:

Continuous

The supply fan is on when the unit is in the occupied period. This is the recommended configuration for most applications, since the LC*H is designed primarily for ventilation and should be ventilating the space continuously during an occupied period.

Demand

The supply fan will operate only when the unit is in the occupied period and there is a call for cooling, heating, dehumidification, or *Venting* (from G input with TSTAT control). Otherwise, the supply fan is off. This configuration is not recommended for most intended applications for the 48/50LC*H units.

Unoccupied Supply Fan Operation

| NAME | DESCRIPTION |
|-----------------|--|
| Demand | The supply fan only operates when there is a call for cooling, heating, dehumidification or <i>Venting</i> during the unoccupied period. |
| Disabled | The supply fan is off during the unoccupied period. |

The sequence of operation is as follows:

Demand

The supply fan will operate only when the unit is in the unoccupied period and there is a call for cooling, heating, dehumidification or venting (G input with TSTAT control). Otherwise, the supply fan is off. Demand is not available for units configured for 100% outdoor air.

Disabled

The supply fan is off during unoccupied period. Cooling, heating, venting, and dehumidification are not performed.

Supply fan control

The supply fan control configuration determines how the supply fan control configuration may be limited based on the cooling and heating demand determination configuration. The following configurations are available:

Supply Fan Control

| NAME | DESCRIPTION |
|-----------------------------------|---|
| Constant Volume (CV) | Supply fan operates at constant speed. |
| Staged Air Volume (SAV) | Supply fan stages between two cooling and two heating speeds based on demand. |
| Duct Pressure Control (SP) | Supply fan modulates based on duct static pressure. |
| Zone Pressure Control (ZP) | Supply fan modulates based on space pressure. |
| Third-party Control | Supply fan modulates based on third-party signal. |

The sequence of operation are as follows:

Constant volume (CV)

When enabled, the supply fan will operate at the constant volume speed setpoint. The supply fan speed is independent of unit demand or mode.

CV control can be used for single-zone space air conditioning, constant ventilation, or constant make-up air applications. CV is only recommended for constant ventilation or make-up air applications requiring constant fan speed. Other fan configurations may provide improved operation or energy savings. Consult local code before using CV units in single-zone space air conditioning applications.

Staged air volume (SAV)

When enabled, the supply fan will operate at the minimum supply fan speed setpoint when the demand is *Low Cool* or *Venting*; and will operate at the maximum supply fan speed setpoint when demand is *High Cool* or *dehum*. For units with heat, the supply fan will operate at the heating minimum supply fan speed setpoint. When the demand is *Low Heat* and will operate at the heating maximum supply fan speed setpoint when the demand is *High Heat*.

SAV control is intended for single-zone space air conditioning applications to provide part load energy savings, quieter operation, and better dehumidification compared to CV or SV VAV operation.

Duct static pressure control (SP)

When enabled, the supply fan will modulate between the minimum and maximum supply fan speed setpoints to maintain the supply duct static pressure at the static pressure setpoint. The supply fan speed is independent of unit demand or mode. This requires a factory-installed option (FIOP) of field provided and installed duct pressure transducer.

Duct static pressure control is intended for single-zone space air conditioning applications for constant volume operation with filter loading, or for 100% outdoor air applications with air terminal units for modulated space ventilation control based on occupancy or CO₂ levels. The LC*H is not intended for multi-zone VAV or VVT applications, multi-zone variable air volume (VAV) or variable volume and temperature (VVT) applications with pressure-independent air terminal units. It is also intended for multi-zone ventilation control with pressure-independent air terminal units for ventilation control.

Zone static pressure control (ZP)

When enabled, the supply fan will modulate between the minimum and maximum supply fan speed setpoints to maintain the building static pressure at the building static pressure setpoint. The supply fan speed is independent of the unit demand or mode. It requires FIOP or field supplied and installed building/zone pressure transducers.

Zone static pressure control is intended for make-up air applications with multiple fixed speed or one or more variable speed exhaust fans. Supply fan zone static pressure control cannot be used simultaneously with exhaust fan building static pressure control.

Third-party control

When enabled, the supply fan will modulate between the minimum and maximum supply fan speed setpoints based on a third party signal. Applying 24-v at the G terminal or

applying a 1 to the network G input will enable the supply fan and a 0-10v signal at the third party supply fan input or the supply fan speed network point is used to modulate the supply fan speed.

A signal <2-v will operate the fan at the minimum fan speed setpoint. A 10-v signal will operate the fan to the maximum fan speed setpoint. A signal in between 2-v and 10-v is scaled to a supply fan speed that corresponds to the equivalent scale between the minimum and maximum supply fan speed setpoints.

Third-party supply fan control is intended for applications with field-provided direct digital control or building automation system control where a specific method of supply fan operation is required.

Exhaust fan control

The following configurations are available:

Exhaust Fan Control

| NAME | DESCRIPTION |
|----------------------------------|---|
| None | The unit is not equipped with an exhaust fan. |
| Two Stage Exhaust | Exhaust fan operates at one of two speeds based on outdoor air damper position. |
| Building Pressure Control | Exhaust fan speed modulates based on building pressure. |
| Third-party Control | Exhaust fan modulates based on a third-party signal. |

The sequence of operation is as follows:

2-stage exhaust

When enabled, the exhaust fan will operate at the minimum exhaust fan speed setpoint when the outdoor air damper position is at or above the exhaust stage 1 outdoor air damper position setpoint. The exhaust fan will operate at the maximum exhaust fan speed setpoint when the outdoor air damper position is at or above the exhaust stage outdoor air damper position setpoint. The exhaust fan is off when the outdoor air damper position is below the exhaust stage 1 outdoor air damper position setpoint.

2-stage power exhaust control is intended for single-zone space air conditioning applications. Building pressure control is recommended for applications with additional sources of exhaust or where the unit will operate for long periods at high outdoor air quantities.

Building static pressure control

When the outdoor air damper is open and the building static pressure is above the building static pressure setpoint, the exhaust fan will modulate between the minimum and maximum speed setpoints to maintain building static pressure at the building static pressure setpoint. This requires an accessory or field provided and installed building pressure transducer.

Building pressure control is intended for and recommended for most 48/50LC*H applications with power exhaust. Exhaust fan building static pressure control cannot be used simultaneously with supply fan zone static pressure control.

Third-party control

When enabled, the exhaust fan will modulate between off and the minimum and maximum exhaust fan speed setpoints based on a third party signal. A 0-10v signal at the third party exhaust fan input or the exhaust fan speed network point is used to modulate the exhaust fan speed.

A signal <2-v will turn the exhaust fan off. A 2-v signal will turn the exhaust fan on and will operate it at the minimum exhaust fan speed setpoint. A 0-v signal will operate the fan at the maximum fan speed setpoint. A signal in between 2-v and 10-v is scaled to an exhaust fan speed that corresponds to the equivalent scale between the minimum and maximum exhaust fan speed setpoints.

Third-party exhaust fan control is intended for applications with field-provided direct digital control or building automation system control where a specific method of exhaust fan operation is required.

Outdoor air damper ventilation control

This configuration determines how the outdoor air damper (with FIOP, accessory economizer or system) behaves during normal operation (free cooling disabled) during the occupied period. The outdoor air damper is closed during the unoccupied period. The following configurations are available:

Outdoor Air Damper Ventilation Control

| NAME | DESCRIPTION |
|---------------------------------|--|
| 100% Outdoor Air Control | Outdoor air damper operates at the maximum position. |
| Supply Fan Mapping | Outdoor air damper stages based on the supply fan speed. |
| Third-party Ventilation | Outdoor air damper modulates based on a third-party input. Free cooling (if enabled) can override the damper position. |
| Third-party Control | Outdoor air damper modulates based on a third-party input. |

The sequence of operations is as follows:

100% outdoor air control

When in the occupied period, the outdoor air damper opens to the maximum damper position.

100% outdoor air control is intended for ventilation applications with CV, ZP, or SP supply fan control.

Supply fan mapping

When in the occupied period and the supply fan is enabled, the outdoor air damper will modulate between the minimum and maximum damper position setpoints to maintain a constant ventilation rate at varying supply fan speeds. The damper position is based on a field configurable four-point damper position curve at different discrete supply fan speeds.

Supply fan mapping control is intended for single-zone space air conditioning applications with SAV or SP, or third-party supply fan control.

Third-party minimum ventilation

When in the occupied period and the supply fan is enabled, the outdoor air damper will modulate between the minimum and maximum damper positions based on a third-party input. The damper is at the minimum position

setpoint when the input is 2-v and at the maximum position setpoint when the input is 10-v. The damper position is scaled between the minimum and maximum positions when the signal is between 2-v and 10-v. When the input signal is less than 2-v, the damper is commanded closed. Free cooling shall override the third-party signal.

Third-party control is intended for applications with field-provided direct digital controls or building automation system control where a specific method of minimum outdoor air damper control is required, but the unit can override third party control for free cooling operation.

Third-party control

When in the occupied period and the supply fan is enabled, the outdoor air damper will modulate between the minimum and maximum damper positions based on a third-party input. The damper is at the minimum position setpoint when the input is 2-v and at the maximum position setpoint when the input is 10-v. The damper position is scaled between the minimum and maximum positions when the signal is between 2-v and 10-v. When the input signal is less than 2-v, the damper is commanded closed.

Third-party control is intended for applications with field provided direct digital controls or building automation system control where a specific method of minimum outdoor air damper control is required, and the unit shall not override the third party control command.

Unoccupied free cooling control

When a free cooling control method other than none is selected, free cooling is allowed to occur during the occupied period. This configuration determines if free cooling is also allowed during the unoccupied period. The following configurations are available:

Unoccupied Free Cooling Operation

| NAME | DESCRIPTION |
|-----------------|--|
| Disabled | Free cooling is not allowed during the unoccupied period. |
| Enabled | Free cooling is allowed during the entire unoccupied period. |

The sequence of operation is as follows:

Disabled

The outdoor air damper will not provide any free cooling operation during the unoccupied period. Free cooling will only be allowed to occur during the unoccupied period. Free cooling will only be allowed to occur during the occupied period.

Enabled

The outdoor air damper shall be available to provide free cooling during the entire unoccupied period.

Free cooling (economizer) operation

This configuration determines what sensors and setpoints the unit checks to disable free cooling. The none configuration will disable free cooling from ever occurring. The following configurations are available:

Free Cooling Checks

| NAME | DESCRIPTION |
|---|---|
| NONE | Free cooling not available. |
| Dry Bulb Free Cooling | Free cooling is disabled based on outdoor air dry bulb. |
| Differential Dry Bulb Changeover | Free cooling is disabled based on differential between outdoor air and return air dry bulb temperature. |
| Enthalpy Changeover | Free cooling is disabled based on outdoor air enthalpy. |
| Differential Enthalpy Changeover | Free cooling is disabled based on differential between outdoor air and return air enthalpy level. |
| Dewpoint Limit Check | Free cooling is disabled based on outdoor air dew point. |

For units without an outdoor air damper or for 100% OA applications, the free cooling control must be set to none to disable free cooling from occurring.

For single-zone space air conditioning applications with an outdoor air damper and where the climate is suitable to allow the use of unconditioned outdoor air for free cooling, the unit can be configured to allow free cooling based on one or more of the following changeover configurations:

- Outdoor dry bulb temperature
- Outdoor air dewpoint
- One of: Outdoor air versus return air temperature differential, outdoor air enthalpy, outdoor air versus return air enthalpy differential

If a free cooling check other than none is selected, then free cooling shall be allowed to occur during the entire occupied period and may occur during the unoccupied period, based on the free cooling operation configuration.

When there is a demand for cooling and free cooling is available based on the occupancy and the free cooling checks, free cooling mode is activated and the unit will modulate between the minimum and maximum configured positions to maintain the unit supply air temperature at the active cooling supply air temperature setpoint.

If there is a cooling demand and free cooling is not available based on occupancy or the free cooling checks, the damper operation shall be based on outdoor air damper ventilation control, configuration (occupied period) or will be closed (unoccupied period).

When free cooling is not active, the outdoor air damper position will be based on the unit operation and the outdoor air damper ventilation control configuration.

None

Free cooling is not used. This configuration is required for 100% outdoor air applications or applications without an economizer.

Dry bulb free cooling

When there is a demand for cooling and the outdoor air dry bulb is above the free cooling dry bulb enable setpoint, free cooling is disabled.

Differential dry bulb free cooling

When there is a demand for cooling and the outdoor air dry bulb is above the return air dry bulb temperature by the differential cut-off setpoint, free cooling is disabled.

Enthalpy free cooling

When there is a demand for cooling and the outdoor air enthalpy is above 75°F and 28 Btu/lb, free cooling is disabled.

Differential enthalpy free cooling

When there is a demand for cooling and the outdoor air enthalpy is above the return air enthalpy, free cooling is disabled.

Dewpoint limit check

When there is a demand for cooling and the outdoor air dewpoint is above the free cooling dewpoint limit setpoint, free cooling is disabled. The dewpoint limit check can be enabled with any of the above changeover selections.

Cooling and heating demand determination

The cooling and heating demand configuration determines which sensors the unit uses to determine a cooling and heating demand and how the unit behaves based on each demand. The appropriate configuration must be selected based on the application to ensure proper unit control. The following configurations are available:

Cooling And Heating Demand Determination

| NAME | DESCRIPTION |
|--|--|
| Space Temperature Control (SPT) | Cooling and heating operates based on space temperature. Intended for single-zone space air conditioning applications. |
| Outdoor Air Temperature Control (OAT) | Cooling and heating operates based on outdoor air temperature. Intended for 100% outdoor air applications. |
| Third-party Control (TSTAT) | Cooling and heating operates based on thermostat style hardwired or network inputs (Y1, Y2, W1, W2). |

Below is a summary of each configuration and demand determination:

Space temperature control (SPT)

SPT is intended for single-zone space air conditioning applications. The unit will follow the occupied setpoints during the occupied period. The supply fan can be configured for continuous or demand during the occupied period and demand or disabled during the unoccupied period. The unit will follow the unoccupied setpoints only if the supply fan is configured for demand operation during the unoccupied period.

Demand is established based on comparing the space temperature to the occupied or unoccupied cooling and heating setpoints and the associated deadbands.

Below is a summary of each demand:

Low Cool (occupied or unoccupied)

If the space temperature is above the occupied or unoccupied cooling setpoint plus the low cool on deadband, the unit demand is set to *Low Cool*. The unit will activate a cooling mode (if available) and will operate to maintain the low cool supply air temperature (SAT) setpoint.

When the space temperature drops below the low cool demand temperature minus the low cool off deadband, the *Low Cool* demand is disabled.

High Cool (occupied or unoccupied)

If the space temperature is above the *Low Cool* demand enable temperature plus the high cool on deadband, the unit demand is set to *High Cool*. The unit will activate a cooling mode (if available) and will operate to maintain the high cool SAT setpoint.

When the space temperature drops below the *Low Cool* demand enable temperature minus 1/2 of the low cool off deadband, the *High Cool* demand is disabled.

Low Heat (occupied or unoccupied)

If the space temperature is below the occupied or unoccupied heating setpoint minus the low heat on deadband, the unit demand is set to *Low Heat*. The unit will activate a heating mode (if available) and will operate to maintain the low heat SAT setpoint.

When the space temperature is above the *Low Heat* demand enable temperature plus the low heat off deadband, the *Low Heat* demand is disabled.

High Heat (occupied or unoccupied)

If the space temperature is below the *Low Heat* demand enable temperature minus the high heat on deadband, the unit demand is set to *High Heat*. The unit will activate a heating mode (if available) and will operate to maintain the high heat SAT setpoint.

When the space temperature is above the *Low Heat* demand enable temperature plus 1/2 of the low heat off deadband, the *High Heat* demand is disabled.

Venting (occupied only)

When there is no demand for cooling or heating from the space, but the supply fan is configured for continuous, the unit demand is set to *Venting*. The unit will monitor the mixed air temperature (MAT) during *Venting* operation. If the MAT is above the vent SAT setpoint by the vent SAT deadband, the unit will operate in a cooling mode (if available) to maintain the SAT at the vent SAT setpoint plus the vent SAT deadband.

If the unit has a modulating heat source, and the MAT is below the vent SAT setpoint by the vent SAT deadband, the unit will operate in a heating mode (if available) to maintain the SAT at the vent SAT setpoint minus the vent SAT deadband.

When the MAT is within the vent SAT deadband from the vent SAT setpoint, the unit will operate in fan-only mode.

None (occupied/unoccupied)

If the supply fan is configured for disabled during the unoccupied period or demand during the occupied or unoccupied period and there is no demand for cooling or heating from the space, the demand is set to none. All components are disabled, and the unit is in standby.

Outdoor air temperature control (OAT)

OAT is intended for ventilation or make-up air applications. The supply fan will operate continuously during the occupied period. The unit will follow the occupied setpoints during the occupied period. The unit is off during the unoccupied period.

Demand is established based on comparing the outdoor air temperature to the occupied cooling and heating setpoints and associated deadbands. Below is a summary of each demand:

Low Cool (occupied only)

If the outdoor air temperature is above the occupied cooling setpoint plus the low cool on deadband, the unit demand is set to *Low Cool*. The unit will activate a cooling mode (if available) and will operate to maintain the 100% OA cooling supply air temperature (SAT) setpoint.

When the outdoor air temperature drops below the *Low Cool* demand temperature minus the low cool off deadband, the *Low Cool* demand is disabled.

High Cool (occupied only)

If the outdoor air temperature is above the *Low Cool* demand enable temperature plus the high cool on deadband, the unit demand is set to *High Cool*. The unit will activate a cooling mode (if available) and will operate to maintain the 100% OA cooling SAT setpoint.

When the outdoor air temperature drops below the *Low Cool* demand enable temperature minus 1/2 of the low cool off deadband, the *High Cool* demand is disabled.

Low Heat (occupied only)

If the outdoor air temperature is below the occupied heating setpoint minus the low heat on deadband, the unit demand is set to *Low Heat*. The unit will activate a heating mode (if available) and will operate to maintain the 100% OA heating SAT setpoint.

When the outdoor air temperature is above the *Low Heat* demand enable temperature plus the low heat off deadband, the *Low Heat* demand is disabled.

High Heat (occupied only)

If the outdoor air temperature is below the *Low Heat* demand enable temperature minus the high heat on deadband, the unit demand is set to *High Heat*. The unit will activate a heating mode (if available) and will operate to maintain the 100% OA SAT setpoint.

When the outdoor air temperature is above the *Low Heat* demand enable temperature plus 1/2 of the low heat off deadband, the *High Heat* demand is disabled.

Venting (occupied only)

When there is no demand for cooling or heating from the outdoor air, cooling and heating are disabled and the unit will operate in fan-only mode.

None (unoccupied only)

During the unoccupied period, the demand is set to none. All unit components are disabled, and the unit is in standby.

Thermostat input control (TSTAT)

Thermostat input control is intended for single-zone space air conditioning applications with a 2-stage cooling or heating thermostat or for space air conditioning, ventilation, or make-up air applications with a third party direct digital controller (DDC) or building automation system (BAS). Control can be accomplished using the hardwired inputs or network inputs.

Cooling and heating demands are available in the occupied period. Cooling and heating demand will only be available in the unoccupied period if the supply fan is configured for demand operation during the unoccupied period.

Demand is established when a cooling (Y1, Y2) or heating (W1, W2) input is activated. If the heating and cooling inputs are activated simultaneously, the demand is set to none.

Low Cool (occupied/unoccupied)

When the Y1 input is activated, the demand is set to *Low Cool*. The unit will activate a cooling mode (if available) to maintain the low cool supply air temperature (SAT) setpoint.

When the Y1 input is deactivated, the *Low Cool* demand is disabled.

High Cool (occupied/unoccupied)

When both the Y1 and Y2 inputs are activated, the demand is set to *High Cool*. The unit will activate a cooling mode (if available) to maintain the high cool SAT setpoint.

When the Y2 input is deactivated, the *High Cool* demand is disabled.

Low Heat (occupied/unoccupied)

When the W1 input is activated, the demand is set to *Low Heat*. The unit will activate a heating mode (if available) to maintain the low heat SAT setpoint.

High Heat (occupied, unoccupied)

When the W1 and W2 inputs are activated, the demand is set to *High Heat*. The unit will activate a heating mode (if available) to maintain the high heat SAT setpoint.

Venting (occupied/unoccupied)

When the fan input (G) is active but there is no active call for cooling or heating (Y1, Y2, W1, W2), the demand is set to vent. The unit will monitor the MAT during vent operation. If the MAT is above the vent SAT setpoint plus the vent SAT deadband, the unit will operate in a cooling mode (if available) to maintain the SAT at the vent SAT setpoint.

If the MAT is below the vent SAT setpoint minus the vent SAT deadband, the unit will operate in a heating mode (if available) to maintain the unit has a modulating heat source and the SAT at the vent SAT setpoint.

When the MAT is within the vent SAT deadband from the vent SAT setpoint, the unit will operate in fan-only mode.

None (occupied/unoccupied)

If the supply fan is configured for disabled during the unoccupied period or demand during the occupied or unoccupied period and there are no active inputs (Y1, Y2, W1, W2, H, G) the demand is set to none. All unit components are off, and the unit is in standby.

Cooling and heating modes

When there is a demand for *Low/High Cool* or *Low/High Heat*, the unit will operate in one of the modes below, based on the unit configuration, unit setpoints, and mixed air temperature.

Below is a summary of available cooling and heating modes:

Mechanical cooling

When there is a demand for cooling, and free cooling is disabled or not available, the unit will enable mechanical cooling mode and will stage the compressors to maintain the active cooling supply air temperature (SAT) setpoint.

Reheat tempered cooling

When the unit is in mechanical cooling mode at the lowest stage of capacity and the SAT is below the active SAT setpoint, the unit will modulate the HGRH to maintain the SAT and the active SAT setpoint.

Economizer free cooling (requires an economizer)

When there is a demand for cooling and free cooling is available, the unit will enable free cooling mode and will modulate the outdoor air damper between the minimum and maximum positions to maintain the active cooling SAT setpoint.

Integrated cooling (requires an economizer)

When there is a demand for cooling, free cooling is active, and the damper is at the maximum damper position, but the SAT is above the active cooling SAT setpoint, integral cooling mode is enabled. The mechanical cooling system is enabled to cool the free cooling air down to the active cooling SAT setpoint.

Heat tempered cooling (requires modulating heat source)

When there is a demand for cooling, the outdoor air damper is at the minimum position, and the mixed air temperature is below the active cooling SAT setpoint, the unit will enable tempering cooling mode and will modulate the heat source to maintain the active cooling SAT setpoint.

Modulating heating (requires modulating gas or electric heat source)

When there is a demand for heating and the mixed air temperature is below the active heating SAT setpoint, the unit will enable heating mode and will modulate the heat source to maintain the active heating SAT setpoint.

Vent

When there is a demand for venting, the unit mode is vent. The unit will monitor the MAT during vent mode and will compare it to the vent SAT set point. If the MAT is too far above or below the vent SAT set point, the unit can enable cool tempered venting or heat tempered venting to temper the air to the Vent SAT set point. Otherwise, the unit will operate in fan only venting mode.

Standby

When there is no demand for heating, cooling, or supply fan, the unit will be in stand-by mode. All unit components are off until there is a demand.

Dehumidify demand

This configuration determines which sensors or inputs the unit monitors to determine if there is a demand to dehumidify. The appropriate configuration must be selected based on the application to ensure proper unit control. The following configurations are available:

Dehumidify Demand

| NAME | DESCRIPTION |
|--|--|
| Space Relative Humidity (SRH) | Dehumidify demand is enabled based on space relative humidity. Intended for single-zone applications. |
| Return Air Relative Humidity (RARH) | Dehumidify demand is enabled based on return air relative humidity. Intended for single-zone applications. |
| Outdoor Air Dewpoint (OADP) | Dehumidify demand is enabled based on outdoor air dewpoint. Intended for 100% outdoor air applications. |
| HUMIDISTAT (H) | Dehumidify demand is enabled when the H input is activated. |

The unit will follow the dehumidify (relative humidity or dewpoint) setpoints during the occupied period and unit will follow the unoccupied setpoints during the unoccupied period if the unit is configured for demand based supply fan operation during the unoccupied period.

When a dehumidify demand is initialized, the unit will select a dehumidification mode and will operate to maintain the unit cooling temperature (approximated by suction line temperature) at the dehumidify cooling coil temperature setpoint. The unit will also operate to maintain the supply air temperature based on a concurring cooling, heating or venting/none demand. Below is a summary of each configuration.

Space relative humidity (SPRH)

SPRH is intended for single-zone space air conditioning applications. A field-provided and installed SPRH sensor is required. When the SPRH is above the SPRH setpoint plus the dehumidify on deadband, a *Dehumidify* demand is initiated.

When the SPRH is below the SPRH setpoint minus the dehumidify deadband, the *Dehumidify* demand is disabled.

Return air relative humidity (RARH)

RARH is intended for single-zone space air conditioning applications. All units include a RARH sensor. When the

RARH is above the RARH setpoint plus the dehumidify on deadband, a *Dehumidify* demand is initiated.

When the RARH is below the RARH setpoint minus the dehumidify off deadband, the *Dehumidify* demand is disabled.

Outdoor air dewpoint (OADP)

OADP is recommended for make-up air or ventilation applications. All units include a OARH and OAT sensor for OADP calculation. When the OADP is above the OADP setpoint plus the dehumidify on deadband, a *Dehumidify* demand is initiated.

When the OADP is below the OADP setpoint minus the dehumidify off deadband, the *Dehumidify* demand is disabled.

Humidistat

Humidistat is intended for single-zone applications with a humidistat or thermostat containing a dehumidification output or any application with a field-provided DDC or BAS system. When the dehumidify input (H) is activated, a *Dehumidify* demand is initiated.

When the dehumidify input (H) is deactivated, the *Dehumidify* demand is disabled.

Dehumidification modes

When there is a demand for dehumidify the unit will operate in one of the modes below, based on the unit configuration, unit setpoints, the outdoor air temperature, and concurrent demand for cooling, heating, venting, or none. Below is a summary of available dehumidification modes:

Dehumidification

When the mechanical cooling system is available and there is a demand for dehumidify, the unit will activate dehumidification mode.

The unit will stage the compressors to maintain the dehumidify cooling coil temperature setpoint. If there is also a demand for cooling, the unit will modulate the HGRH to maintain the active low cool, high cool, or 100% OA cool, SAT setpoint. If there isn't a demand for cooling, the unit will modulate the HGRH to maintain the vent SAT setpoint.

Recommended Control Configuration by Application Type

| CONFIGURATION | DEDICATED VENTILATION (100%) | MAKE-UP AIR (100% OA) | SINGLE-ZONE SPACE AIR CONDITIONING | THIRD-PARTY CONTROL |
|---|--|-----------------------|---|--|
| Occupancy Control | Unit Schedule, Occupancy Switch, BAS Occupancy (CCN or BACnet) | | | |
| Occupied Supply Fan Operation | Continuous | | | |
| Unoccupied Supply Fan Operation | Disabled | | Disabled or Demand | |
| Supply Fan Control | CV, SP | CV, SP, ZP | CV, SAV, or SP | Third-party, CV, SAV, or SP |
| Exhaust Fan Control | None or BP | None | 2 or BP | Third party, None, 2-stage, or BP |
| Outdoor Air Damper Ventilation Control | 100% OA | 100% OA | Supply fan mapping | Third-party, Supply fan mapping, or IAQ |
| Unoccupied Free Cooling Operation | None | | None, entire time, or minutes before occupied | |
| Free Cooling Control (Dry Climate) | None | | DB or diff DB | DB or diff DB |
| Free Cooling Control (Humid Climate) | None | | Enthalpy or diff enthalpy or DB/diff DB + DP | Enthalpy or diff enthalpy or DB/diff DB + DP |
| Cooling and Heating Demand | OAT | OAT | SPT or TSTAT | TSTAT, OAT, SPT, or RAT |
| Cooling and Heating Control | SAT | | | |
| Dehumidification Demand | OADP | OADP | RARH, SPRH, or humidistat | Humidistat, SPRH, or RARH |
| Dehumidification Control | CCT | | | |

Special operating modes

SmartVu™ controls are available with special operating modes to override normal unit operation to meet unique conditions.

Special Operating Modes

| NAME | DESCRIPTION |
|--------------------------------------|--|
| Service Test | Normal operation is disabled to allow component or system testing. |
| Service Run | Normal unit operation is enabled and unit components and systems can be manipulated for testing. |
| Pre-occupancy Purge | The outdoor air damper is open, and the indoor fan is on to ventilate the building before occupancy. |
| Temperature Compensated Start | The indoor fan and cooling or heating systems are on to pre-cool or pre-heat the building before occupancy. |
| Emergency Shutdown | The unit operation is disabled due to: <ul style="list-style-type: none"> – Indoor fan door switch – Phase monitor shutdown – Active emergency shutdown input – Emergency shutdown from the user interface |
| Fire Shutdown | The unit operation is disabled due to an active fire or smoke shutdown input. |
| Fire Pressurization | The indoor fans are on at the max speed and the outdoor air damper is open to its max position to pressurize the building. The exhaust fans are off. |
| Fire Evacuation | The indoor fans are off, and the outdoor air damper is closed. The exhaust fans are on at the max speed to de-pressurize the building. |
| Smoke Purge | The indoor fans and exhaust fans are on at max speed and the outdoor air damper is open to max position to purge smoke from the building. |

Advanced control functions

SmartVu™ controls are available with additional advanced control functions to meet application or operational requirements.

Advanced Control Functions

| NAME | DESCRIPTION |
|----------------------------|---|
| Cool Demand Limit | Increases the effective occupied cooling setpoint based on a setpoint, limit switches, or analog input. |
| Heat Demand Limit | Decreases the effective occupied heating setpoint based on a setpoint, limit switches, or analog input. |
| Cool Capacity Limit | Restricts the maximum cooling capacity (%) based on a setpoint, limit switches, or analog input. |
| Heat Capacity Limit | Restricts the maximum heating capacity (%) based on a setpoint, limit switches, or analog input. |
| Economizer FDD | Provides economizer fault detection and diagnostics. |
| RAD Mapping | For units with an independent return air damper actuator, this allows modification of RAD position based on OAD position. |
| IAQ Reset | Resets the damper ventilation position based on IAQ switch or sensor. |
| OAQ Shutoff | Prevents free cooling and ventilation based on an OAQ sensor or switch. |

SmartVu Controls Inputs And Outputs

| MAIN BASE BOARD | | | | |
|-----------------|---------|---------------------------|--------------------------------------|---------------------------|
| TYPE | IO NAME | CONNECTOR | SIGNAL/SENSOR | IO TYPE |
| ANALOG INPUT | AI1 | J8, 1, 4 | Supply Air Temperature | 10k Ohm Thermistor |
| | AI2 | J8, 2, 5 | Return Air Temperature | 10k Ohm Thermistor |
| | AI3 | J8, 3, 6 | Outdoor Air Temperature | 10k Ohm Thermistor |
| | AI4 | TB5, 1-2 | Space Temperature | 10k Ohm Thermistor |
| | AI5 | TB5, 2-3 | Space Temperature Offset | 100k Ohm Thermistor |
| | AI6 | TB5, 5-6 | Indoor Air Quality Level | 4-20mA Input |
| | AI7 | J7, 1, 5 | Return Air Relative Humidity | 4-20mA Input |
| | AI8 | J7, 2, 7 | Outdoor Air Relative Humidity | 4-20mA Input |
| | AI9 | J9, 1-2, 5 | Suction Pressure | 0-5vdc Input |
| | AI10 | J9, 4-3, 6 | Discharge Pressure | 0-5vdc Input |
| | AI11 | J7, 3, 8 | Economizer Position Feedback | 0-10vdc Input |
| DISCRETE INPUT | DI1 | J6, 1-2 | Heat Alarm/Limit Switch | 24vac Discrete Input |
| | DI2 | J4, 1-4 | Condensate Overflow Switch | 24vac Discrete Input |
| | DI3 | J5, 1-4 | Smoke Detector | 24vac Discrete Input |
| | DI4 | QC, 3-4 | Indoor Fan Limit Switch | 24vac Discrete Input |
| | DI5 | QC, 1-2 | High Pressure Switch | 24vac Discrete Input (NC) |
| | DI6 | TB1, 2 | Thermostat G | 24vac Discrete Input |
| | DI7 | TB1,3 | Thermostat Y1 | 24vac Discrete Input |
| | DI8 | TB1, 4 | Thermostat Y2 | 24vac Discrete Input |
| | DI9 | TB1, 5 | Humidistat Switch (Y3) | 24vac Discrete Input |
| | DI10 | TB1, 6 | Thermostat W1 | 24vac Discrete Input |
| | DI11 | TB1, 7 | Thermostat W2 | 24vac Discrete Input |
| | DI12 | TB3, 1-2 | Filter Status Switch | 24vac Discrete Input (NO) |
| | DI13 | TB3, 3-4 | Remote Shutdown/Occupancy Switch | 24vac Discrete Input |
| | DI14 | TB3, 5-6 | Phase Monitor | 24vac Discrete Input |
| ANALOG OUTPUT | AO1 | J7, 4, 8 | Economizer Damper Position Command | 4-20mA Output |
| | AO2 | J10, 1-4 | Outdoor Fan Speed 1 | PWM Output |
| | AO3 | J11, 1-4 | Outdoor Fan Speed 2/4 | PWM Output |
| | AO4 | J12, 1-4 | Outdoor Fan Speed 3 | PWM Output |
| DISCRETE OUTPUT | DO1 | J3E, 2, 4 | Heat Enable | Relay Output |
| | DO2 | J3E, 1, 3 | Damper Override Relay (Formerly HIR) | Relay Output |
| | DO3 | J3D, 3, 6 | Compressor A1 | Relay Output |
| | DO4 | J3D, 2, 5 | Compressor A2 | Relay Output |
| | DO5 | J3D, 1, 4 | Crankcase Heater A | Relay Output |
| | DO6 | J3C, 1, 2 | Power Exhaust Enable | Relay Output |
| | DO11 | TB2, 3-4 | Alarm Output | Relay Output |
| NGC BOARD | | | | |
| TYPE | IO NAME | CONNECTOR | SIGNAL/SENSOR | IO TYPE |
| ANALOG INPUT | AI1 | J16-5 | Supply Air Relative Humidity | 4-20mA Input |
| | AI2 | J16-6 | Cooling Coil Temperature | 5k Ohm Thermistor |
| | | | | 4-20mA Input |
| | AI6 | J15-5 | OAD Third Party Modulation | 4-20mA Input |
| | AI7 | J15-4 | Supply Duct Pressure | 4-20mA Input |
| | AI8 | J15-3 | Space Relative Humidity | 4-20mA Input |
| | AI9 | J15-2 | SF Third Party Modulation | 4-20mA Input |
| AI10 | J15-1 | EF Third Party Modulation | 4-20mA Input | |
| DISCRETE INPUT | DI1 | J13-5 | Fire Shutdown | 24vac Discrete Input |
| | AO2 | J14-5 | Power Exhaust Speed | 0-10vdc Output |
| EXV BOARD | | | | |
| STEPPER | Step1 | J2A, 1-5 | Modulating Reheat Valve | Stepper Motor |
| AUXILIARY BOARD | | | | |
| ANALOG INPUT | AI1 | J6-1,2 | Mixed Air Temperature | 10k Ohm Thermistor |
| | AI3 | J8-1,2,3 | Building Pressure | 0-10vdc Output |
| ANALOG OUTPUT | AO1 | J4-1,2 | Indoor Fan Speed | 0-10vdc Output |
| | AO2 | J5-1,2 | Modulating Gas/SCR Heat | 0-10vdc Output |

General

The 48/50LC*H units can be used in a wide variety of light commercial applications, including ventilation, make-up air, and space air conditioning.

In a 100% outdoor air application, such as ventilation or make-up air, the LC*H unit is designed to deliver constant, neutral temperature air to the space. A separate space air conditioning system is required to maintain space conditions.

The LC*H unit can also operate to condition mixed quantities of outdoor air (<50%) and return air from the space, and deliver cool, neutral, or warm air to the space to help maintain space conditions.

The LC*H unit is not designed to condition high quantities of outdoor air and simultaneously maintain space temperature and humidity levels. The LC*H unit is also intended for light commercial applications, and is not meant for critical or process applications.

Dedicated ventilation system

Overview

The Carrier 48/50LC*H unit can be used as a dedicated ventilation system to provide conditioned, 100% outdoor air to ventilate one or more spaces in a building. Using a dedicated ventilation system is common for large single-zone spaces with variable occupancy (conference rooms, auditoriums) or multi-zone buildings with different ventilation requirements in each zone (schools, offices). Dedicated ventilation units are common in buildings that require high indoor air quality (schools, retail) or that use space air conditioning units that can't access outdoor air for ventilation (VRF, WSHP).

Outdoor air is used to ventilate the space because it is typically cleaner and has higher oxygen levels than the air inside the space that has been contaminated by people,

fixtures, and activities. The outdoor air can contain some contaminants, such as dirt, pollen, and odors, so the dedicated ventilation system will need to clean the air before sending it to the space.

The biggest challenge to using outdoor air for ventilation is that its temperature and humidity levels can vary widely based on the time of year and geographic location. Sending air that's cold, or too humid to the space can cause comfort issues and create extra load for the space air conditioning units. To prevent these issues, the dedicated ventilation system will condition the outdoor air to have a dry bulb and dewpoint temperature that's near the design space air temperature, typically 65°F to 75°F dry bulb and <60°F dewpoint. This "neutral air" won't cool, heat, or humidify the space and prevents fighting with the space cooling and heating units.

Typical operation

Occupancy is determined based on the unit schedule, occupancy switch, or BAS schedule. The 48/50LC*H unit can be configured to operate only when the space or building is occupied. When in the occupied period, the supply fan will turn on and will draw outdoor air into the unit through the outdoor air intake economizer, then through the filters (2 in. or 4 in.) to remove contaminants from the air. The filtered outdoor air then passes through the evaporator coil, then the hot gas reheat coil, and is pulled into the inlet of the supply fan. Finally, the supply fan pushes the outdoor air over the heating coil (if equipped) and to the supply duct to be delivered to the space.

See figure 48/50LC*H with Economizer and Barometric Relief - 100% Outdoor Air Operation on page 65 for the 100% outdoor airflow path for a 48/50LC*H with economizer and barometric relief.

48/50LC*H with Economizer and Barometric Relief — 100% Outdoor Air Operation

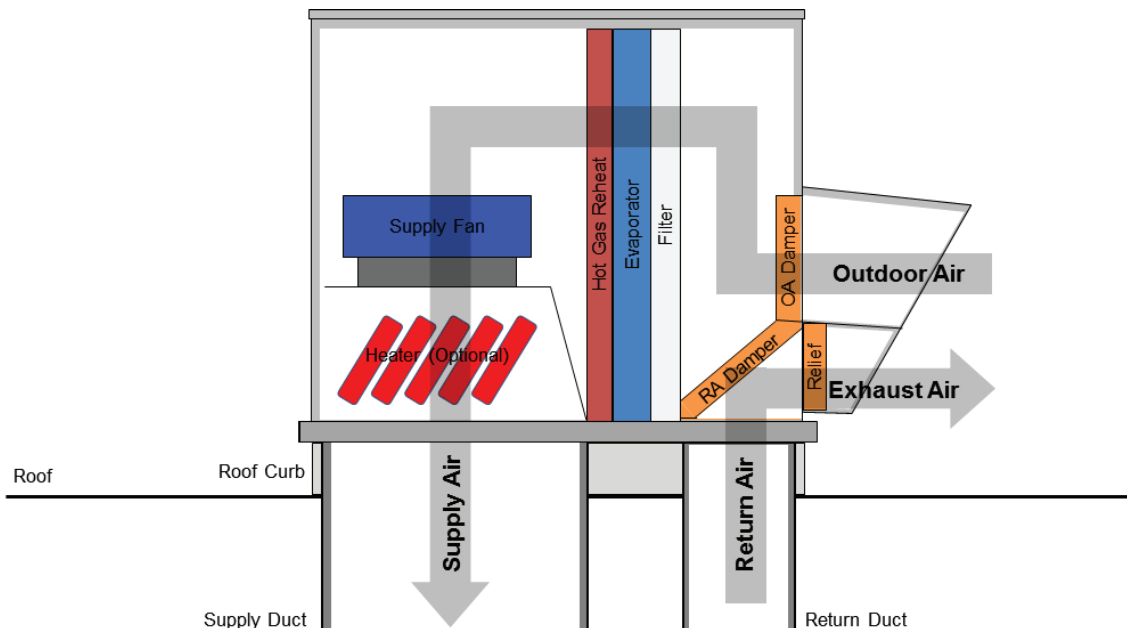

The Carrier SmartVu™ controls can be configured to operate unit cooling and heating (if equipped) based on outdoor air dry bulb temperature, and dehumidification based on outdoor air dewpoint temperature. When the outdoor air is hot, but not humid (>75°F dry bulb, <60°F dewpoint), the 48/50LC*H compressors are staged to cool the hot outdoor air to a neutral dry bulb temperature (65°F to 75°F) as it passes through the evaporator coil. The air then passes through the inactive hot gas reheat coil (standard on all 48/50LC*H units) and inactive heating coil (if equipped) and is sent to the space as neutral air (65°F to 75°F dry bulb, <60°F dew point).

When the outdoor air is both hot and humid (>75°F dry bulb, >60°F dewpoint), the 48/50LC*H compressors are staged to dehumidify the outdoor air to a neutral dewpoint temperature (<60°F), which also cools the air (50°F to 60°F dry bulb) as it passes through the evaporator coil. The cooled, dehumidified air then passes through the active hot gas reheat coil (standard on all 48/50LC*H units) where it's heated to a neutral dry bulb temperature (65°F to 75°F) by modulating the quantity of hot refrigerant gas flowing inside the reheat coil. The reheated air then passes over the inactive heater coil (if equipped) and is sent to the space as neutral air (65°F to 75°F dry bulb, <60°F dew point).

For applications where the outdoor air can be cold (<50°F), the 48/50LC*H unit can be equipped with a modulating gas or electric heating coil. After the cold outdoor air passes through the inactive evaporator and hot gas reheat coils, it passes through the active heating coil where it is heated to a neutral dry bulb temperature (65°F to 75°F) by modulating the heater capacity, before being sent to the space as neutral air (65°F to 75°F dry bulb, <60°F dew point).

When the outdoor air is not cold, hot, or humid (>65°F and <75°F dry bulb, <60°F dewpoint), it will pass through the inactive evaporator, hot gas reheat, and heating coil (if equipped) and will be sent to the space unconditioned as neutral air (65°F to 75°F dry bulb, <60°F dew point).

The quantity of outdoor air required to properly ventilate the space will vary by application. Some applications require a constant volume of ventilation air, others require variable quantities of ventilation air. The Carrier SmartVu controls can be configured to operate the Carrier EcoBlue™ supply fan at a constant speed or at variable speeds to control the volume of ventilation air that is conditioned by the unit and delivered to the space. Variable speed supply fan operation can be based on duct static pressure (with air terminal units for demand-controlled ventilation) or a third-party signal (to vary).

To help ensure proper space ventilation and prevent overpressurizing the space, some air must be removed from the space. The 48/50LC*H unit can be equipped with a pressure-activated damper (barometric relief) or a modulating power exhaust system accessory to relieve the excess building pressure. The pressure-activated damper will open when building pressure is high enough to force the damper open, allowing air to exit the space. The modulating power exhaust system is controlled by the Carrier SmartVu controls which vary the fan speed to adjust how much air is

exhausted from the space. The power exhaust can be modulated based on a pressure set point or a third party signal.

Considerations

When using a dedicated ventilation system, a separate space air conditioning system is required to maintain space comfort through space cooling, heating, dehumidification, or humidification. The dedicated ventilation system should not be utilized for space air conditioning.

For applications requiring the ventilation system to be oversized to deliver very dry air to the space to offset the space latent load, a dedicated outdoor air system (DOAS) should be utilized.

The LC*H unit is a light commercial product and is not designed for use in critical or process applications or application that require precise supply air or space condition control.

For applications requiring low dew point levels for space latent load offset, a dehumidifying dedicated outdoor air system (DOAS) is recommended.

Make-up air system (MUA)

Overview

The Carrier 48/50LC*H unit can be used as a make-up air system (MUA) to provide conditioned, 100% outdoor air to replace the air that has been exhausted from the space. Some activities can contaminate the space air beyond what a standard filtration system can clean, because of the type (grease, moisture) or particle size (smoke, chemicals) of the contaminate. The contaminated air must be prevented from spreading within the space or to other spaces, and then removed from the space. A common method of collecting and removing contaminated air is to use an exhaust fan. The exhaust fan pulls contaminated air from the space and/or rejects the contaminated air to the outdoors.

The quantity of air that has been removed from the space must be fully or partially replaced to prevent the space from having a negative pressure. The MUA system conditions and supplies outdoor air and sends it to the space to "make-up" the exhaust air and maintain space pressure. MUA systems can be used to provide make-up air directly to a single-zone (kitchens, locker rooms), a common area in a building (hallways, corridors), or to individual spaces in a building (hotels, dormitories).

Like ventilation applications, outdoor air is used to replace air exhausted from the space because it is usually cleaner than air from other spaces inside the building. Additionally, since air is being exhausted from inside the building to the outside, air needs to be pulled from the outside to inside the building to maintain pressure.

The downside of using outdoor air for make-up air is that it can be very hot, cold, or humid and can be contaminated by dirt, pollen, and odors. The MUA system will filter and condition the outdoor air before it is sent to the space. MUA systems are typically sized to condition the outdoor air to "neutral conditions" before supplying it to the space. Just like ventilation applications, providing neutral make-up air (65°F to 75°F dry bulb and <60°F dewpoint) helps prevent overcooling or overheating the space.

Typical operation

The occupancy period is determined based on the local schedule or BAS schedule. The 48/50LC*H occupancy switch input can also be field configured to link unit occupancy with an external exhaust system. In the occupied period, the unit supply fan will pull outdoor air into the unit through the outdoor air intake (economizer), then through a filter to remove contaminants from the air. The filtered outdoor air then passes through the evaporator coil and hot gas reheat coil and is pulled into the inlet of the supply fan. Finally, the supply fan pushes the outdoor air over the heating coil (if equipped) and to the supply duct to be delivered to the space. See figure 48/50LC*H with Economizer - 100% Outdoor Air Operation on page 67 for the 100% outdoor airflow path for a 48/50LC*H.

When the outdoor air is both hot and humid ($>75^{\circ}\text{F}$ dry bulb, $>60^{\circ}\text{F}$ dewpoint), the 48/50LC*H compressors are staged to dehumidify the outdoor air to a neutral dewpoint temperature ($<60^{\circ}\text{F}$), which also cools the air (50°F to 60°F dry bulb) as it passes through the evaporator coil. The cooled, dehumidified air then passes through the active hot gas reheat coil (standard on all 48/50LC*H units) where it is heated to a neutral dry bulb temperature (65°F to 75°F) by modulating the quantity of hot refrigerant gas flowing inside the reheat coil. The reheated air then passes over the inactive heater coil (if equipped) and is sent to the space as neutral air (65°F to 75°F dry bulb, $<60^{\circ}\text{F}$ dew point).

For applications where the outdoor air can be cold ($<50^{\circ}\text{F}$), the 48/50LC*H unit can be equipped with a modulating gas or electric heating coil. After the cold outdoor air passes through the inactive evaporator and hot

gas reheat coils, it passes through the active heating coil where it is heated to a neutral dry bulb temperature (65°F to 75°F) by modulating the heater capacity, before being sent to the space as neutral air (65°F to 75°F dry bulb, $<60^{\circ}\text{F}$ dew point).

When the outdoor air is not cold, hot, or humid ($>65^{\circ}\text{F}$ and $<75^{\circ}\text{F}$ dry bulb, $<60^{\circ}\text{F}$ dewpoint), it will pass through the inactive evaporator, hot gas reheat, and heating coil (if equipped) and will be sent to the space unconditioned as neutral air (65°F to 75°F dry bulb, $<60^{\circ}\text{F}$ dew point).

Where possible, a separate space air conditioning system should be used in conjunction with the MUA system to provide space comfort control.

The quantity of outdoor air that needs to be provided to the space to maintain space pressure is dependent on the application and configuration of the exhaust systems. Applications with one or more constant volume exhaust fans that operate continuously will usually need a constant volume of make-up air. Applications with one or more modulating exhaust fans or multiple exhaust fans serving a single space with intermittent operation may require a variable volume of make-up air.

The Carrier SmartVu™ controls can be configured to operate the Carrier EcoBlue™ supply fan at constant speed or variable speed to adjust the volume of make-up air that is conditioned by the unit and delivered to the space. Variable speed supply fan operation can be based on space static pressure (for variable speed exhaust or spaces with multiple, independent exhausts), outdoor air measuring (for constant volume), or a third-party signal.

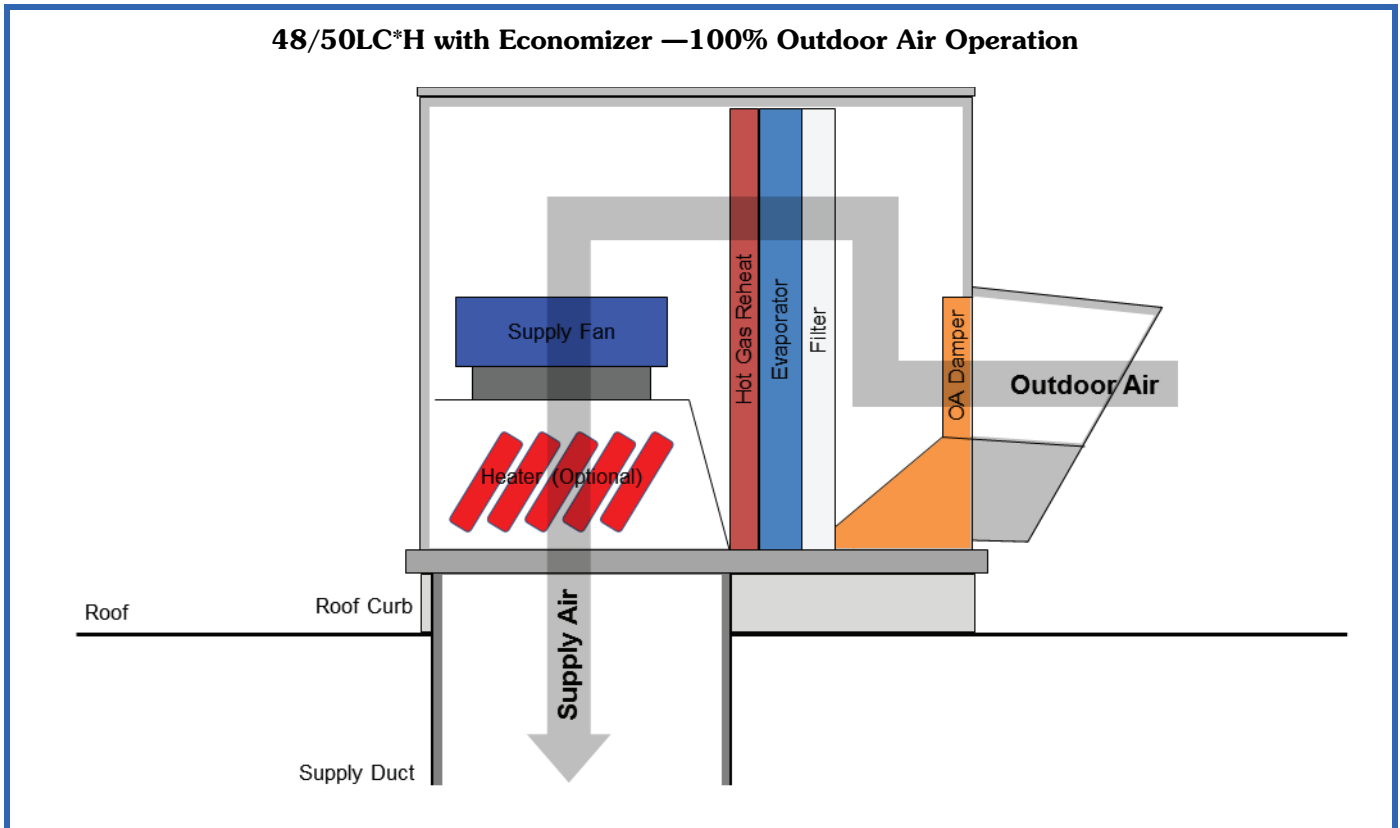

Considerations

The LC*H is a light commercial product and is not designed for critical or process applications or, applications that require precise supply air or space air condition control.

Even though the 48/50LC*H unit can be equipped with barometric relief, accessory powered exhaust, a separate exhaust system is cleanable or has been designed to handle contaminated air.

Single-zone space air conditioning

Overview

The Carrier 48/50LC*H unit can be used to provide comfort cooling and heating, for a single space using normal quantities of outdoor air (<50%) for ventilation or make-up air. Operation with ventilation air and space air conditioning is common for single-zone applications with high occupancy variation (conference rooms, auditoriums).

Operation with make-up air and space-air conditioning is common for single-zone applications with high quantities of exhaust (classrooms with exhaust hoods, locker rooms).

Using a single unit to provide space air conditioning with high quantities of outdoor air (>50%) is not recommended. Selecting a single unit to handle both high outdoor air and space air conditioning can be challenging and will result in poorer space comfort than selecting separate systems to condition the outdoor air and space air.

Typical operation

Occupancy is determined by the unit schedule, occupancy switch, or BAS schedule. The 48/50LC*H unit can be configured for continuous supply fan operation when the space is occupied or operation only where there is a demand for space cooling, heating, or dehumidification during the occupied or unoccupied period.

For units with an economizer, a mix of outdoor air and return air are pulled into the unit by the supply fan, then through a filter to remove contaminants from the air. The filtered, mixed air then passes through the evaporator coil, hot gas reheat coil, and is pulled into the inlet of the supply fan. Finally, the air is pushed over the heating coil (if equipped) and to the supply duct to be delivered to the space.

48/50LC*H Airflow Side View — Mixed Air with Economizer and Barometric Relief

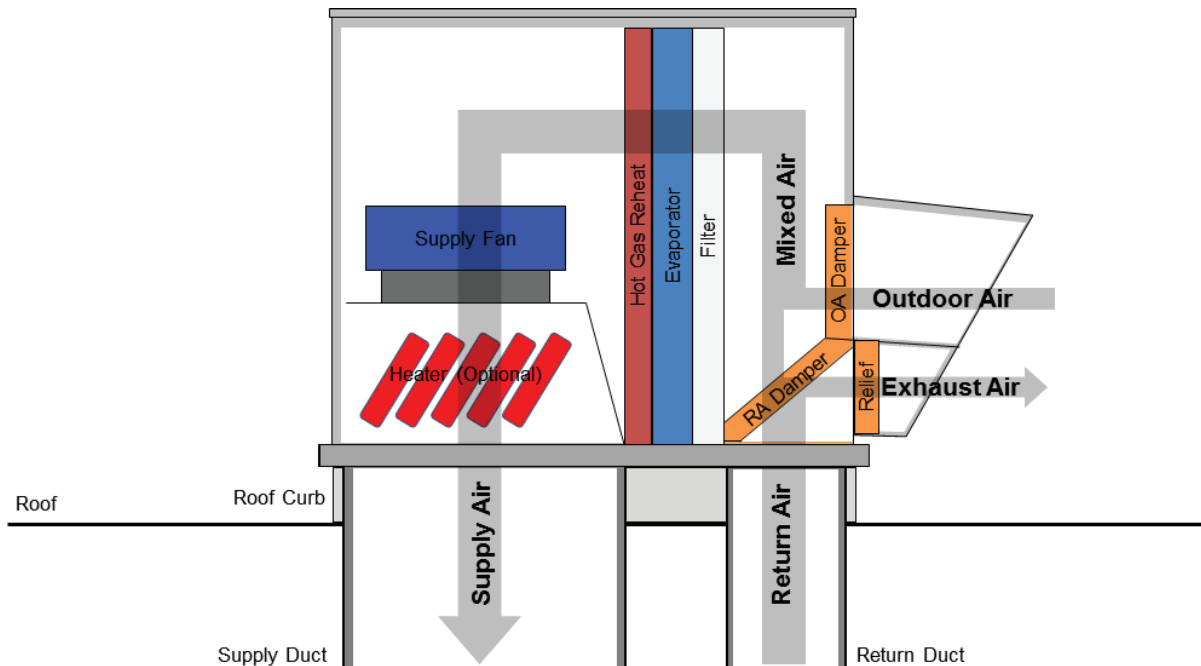

See figure 48/50LC*H Airflow Side View - Mixed Air with Economizer and Barometric Relief on page 68 for the mixed outdoor air and return airflow path for a 48/50LC*H.

The Carrier SmartVu™ controls can be configured to operate cooling and heating based on space temperature or a third party signal from a DDC controller or thermostat. Dehumidification can be operated based on supply air dewpoint temperature, return air relative humidity, space relative humidity, or a third-party signal from a DDC control or thermostat with dehumidification output.

When the space is hot but not humid and the mixed air temperature is hot (>75°F dry bulb) the 48/50LC*H compressors are staged to cool the mixed outdoor air and return air to a cool dry-bulb (55°F to 65°F) as it passes through the evaporator coil. The cooled air then passes through the inactive hot gas reheat coil (standard on all 48/50LC*H units) and inactive heating coil (if equipped) and is sent to the space.

When the space is both hot and humid and the mixed air temperature is hot (>75°F dry bulb), the 48/50LC*H compressors are staged to cool and dehumidify the mixed outdoor and return air to a cool dry-bulb (55°F to 65°F) and neutral dewpoint (<60°F) temperature as it passes through the evaporator coil. The cooled and dehumidified air then passes through the hot gas reheat coil, where it can be heated to a cool dry bulb temperature (55°F to 65°F) if it's too cold by modulating the quantity of hot refrigerant gas flowing inside the coil. The cooled and dehumidified air then passes through the inactive heating coil (if equipped) and to the space.

When the space is humid, but not hot, and the mixed air isn't cold (>60°F) the 48/50LC*H compressors are staged to dehumidify the mixed outdoor and return air to a neutral dewpoint temperature (50°F to 60°F), which also cools the air (<60°F dry bulb) as it passes through the evaporator coil. The cooled, dehumidified air then passes through the active hot gas reheat coil, where it's heated to a neutral dry bulb temperature (65°F to 75°F) by modulating the quantity of hot refrigerant gas flowing inside the reheat coil. The reheated air then passes over the inactive heater coil (if equipped) and is sent to the space as neutral air (65°F to 75°F dry bulb, <60°F dew point).

For applications where space heating is required or the outdoor air can be cold (<50°F dry bulb), the 48/50LC*H unit can be equipped with a modulating gas or electric heating coil. When the space is cold and the mixed air temperature is cold (<60°F), the cold mixed air passes through the inactive evaporator and hot gas reheat coils, then through the active heating coil where it is heated to a warm dry bulb temperature (85°F to 105°F) by modulating the heater capacity, before being sent to the space.

When the space is hot and the mixed air temperature is cold (<50°F), the cold outdoor air passes through the inactive evaporator and hot gas reheat coils, then through the active heating coil where it is heated to a cool dry bulb temperature (55°F to 65°F) by modulating the heater capacity, before being sent to the space as cool air (55°F to 65°F dry bulb, <60°F dew point).

When the outdoor air is not cold, hot, or humid (>55°F and <80°F dry bulb, <60°F dewpoint) and the space is not cold, hot or humid, the mixed air will pass through the inactive evaporator, hot gas reheat, and heating coil (if equipped) and will be sent to the space unconditioned as neutral air (55°F to 80°F dry bulb, <60°F dew point).

If the space is not cold or hot, but the mixed air temperature is cold or hot (<55°F or >80°F), the unit can be configured to enable cooling or heating to temper the mixed air to a neutral temperature (65°F to 75°F dry bulb). This tempering operation is intended to prevent high quantities of outdoor air from negatively impacting the space when the space is satisfied.

The quantity of outdoor air needed to provide proper space ventilation or make-up will vary by application. Some applications require a constant volume of outdoor air, while others require variable quantities of outdoor air. The Carrier SmartVu controls can be configured to operate the 48/50LC*H outdoor air damper based on a fixed damper position or modulating damper position based on fan speed, space CO₂ levels (for demand-controlled ventilation) or a third-party signal.

In ventilation applications, the 48/50LC*H unit can be equipped with a pressure-activated damper (barometric relief) or a modulating power exhaust system accessory to relieve excess pressure from the space. The pressure-activated damper will open when space pressure is high enough to force the damper open, allowing air to exit the space. The modulating power exhaust system is controlled by the Carrier SmartVu controls which vary the fan speed to adjust how much air is exhausted from the space. The power exhaust can be modulated based on the outdoor air damper position, a building pressure setpoint, or a third party signal.

Consideration

When applying the 48/50LC*H unit in a make-up air application, a separate exhaust or building relief system should be used to remove contaminated space air. Do not use the accessory power exhaust or field-installed energy recovery ventilators (ERV) with contaminated air.

Using a single unit to provide space air conditioning with high quantities of outdoor air not recommended.

The LC*H unit is a light commercial product and is not designed for critical or process applications or applications requiring precise supply air or space air condition control.

Operation and application limitations

Low ambient cooling and dehumidification

The 48/50LC*H unit can operate at the lowest stage of mechanical cooling down to an ambient temperature of 40°F when the entering evaporator air temperature is no lower than 60°F. The lowest stage of mechanical dehumidification (compressors with HGRH) is limited to ambient temperatures of no lower than 60°F with an entering evaporator temperature of no lower than 60°F.

Low ambient mechanical cooling and dehumidification operation may be additionally limited by airflow or entering coil conditions. Cooling and dehumidification operation below 60°F ambient should be accomplished using an air-side economizer and a modulating heat source.

High ambient cooling and dehumidification

48/50LC*H units can operate mechanical cooling up to an ambient temperature of 125°F with a maximum evaporator entering air temperature of 115°F. Mechanical dehumidification is limited to a maximum of 115°F ambient with up to 105°F entering evaporating temperature.

High ambient mechanical cooling and dehumidification operation may be additionally limited by airflow or entering coil conditions.

Cooling and dehumidification supply air conditions

The 48/50LC*H unit is designed to operate with an evaporator leaving air dew point temperature between 56°F to 60°F during cooling or dehumidification operation. The unit can operate in cooling mode with entering air conditions below 50°F dewpoint. Applications with a supply air dew point above 60°F are not recommended, as the unit is not providing proper dehumidification which can lead to humidity issues in the space or building.

Low ambient heating

The 48LC*H units can operate gas heating with a heater entering air temperature down to -10°F. The maximum available temperature rise will depend on unit and heater size. Condensation of flue gases may occur when operating gas heat with low entering air temperatures. All 48LC*H units include a gas heater condensate connection that requires a field provided and installed condensate trap. For applications where ambient temperatures drop below freezing, the condensate trap requires field provided freeze protection.

NOTE: Gas flue condensate can be acidic and may cause damage to some roofing materials. Consult with local codes and roof installer for flue gas condensate draining guidance.

The 50LC*H units can operate electric heating with a heater entering air temperature down to 50°F. The maximum available temperature rise will vary by unit and heater size.

Heating high entering air and high discharge temperature

The 48LC*H unit can operate gas heating with a heater entering air temperature up to 80°F. The maximum allowable discharge air temperature is 125°F.

The 50LC*H unit can operate electric heating with a heater entering air temperature up to 80°F. The maximum allowable discharge air temperature is 125°F.

Minimum airflow

The minimum allowable part-load airflow is 130 cfm/ton at the lowest stage of capacity. The minimum airflow may be limited by unit operating conditions or entering air conditions.

The minimum recommended full load airflow is 175 cfm/ton for 100% outdoor air applications or 260 cfm/ton for mixed air applications.

Maximum airflow

The maximum recommended airflow for mixed air applications is 350 cfm/ton.

Propane heating

The standard 48LC*H gas heaters are intended for natural gas. For propane applications, a field-installed natural gas to propane conversion kit is available.

High altitude heating

The standard 48LC*H natural gas heater is intended for applications up to 2000 ft. A field-installed high altitude conversion kit is available for applications up to 7000 ft in elevation. The heater input and output will be derated by 4% for every 1000 ft in elevation over 2000 ft.

Exhaust

The SmartVu controls on the 48/50LC*H has provisions to enable and modulate a field-provided and installed exhaust fan. See the controls section of this document for exhaust fan control guidance.

Space air conditioning

Selecting a single unit to handle both high outdoor air and space air conditioning can be challenging and will result in poorer space comfort and higher energy consumption than selecting separate systems to condition the outdoor air and space air independently. Carrier recommends using separate systems to condition the outdoor air and condition the space.

Airside linkage

The SmartVu controls on the 48/50LC*H units are not currently compatible with Carrier CCN or Open air side linkage. A separate control input or BAS signal is required for occupancy status and advanced operation. The lack of airside linkage support also prevents the 48/50 LC*H unit from being used as a primary air source in a Carrier CCN or Open variable volume and temperature (VVT) system. Additional field provided and programmed controls would be required for unit operation in a CCN or Open VVT system.

Critical applications

The LC*H unit is a light commercial product and is designed for light commercial applications. The LC*H unit is not recommended for use in critical applications where precise supply air or space conditions must be maintained. The LC*H is also not designed for low supply air dewpoint or relative humidity operation. Consult application engineering for additional application guidance.

Equipment sizing and guidance

General

The 48/50LC*H unit is included in the Carrier ECat Packaged RTU Builder for equipment selections, sizing, and full load performance modeling.

The sizing method for high outdoor air systems is different than sizing conventional space air conditioning systems. Use the following guidelines when sizing the 48/50LC*H unit for 100% outdoor air.

100% outdoor applications

Consider the following sizing recommendations when selecting the 48/50LC*H unit for 100% outdoor air applications, ventilation or make-up air.

Supply fan

For dedicated ventilation applications, the supply fan is sized to meet the volume of ventilation air required by code (ASHRAE 62.1 or other local code) or alternate design guidelines (LEED or other). The ventilation air volume should be specified by the system design engineer or customer.

Some ventilation applications can also include a direct space exhaust (such as a bathroom exhaust) that requires additional outdoor air to maintain space pressure. In these applications, the unit supply fan can be upsized to provide additional outdoor air to make up the exhausted air.

For make-up air applications, the unit supply fan is typically sized to meet or be slightly lower than the volume of air being removed by the exhaust fan. The ventilation air volume should be specified by the system design engineer or customer.

Once the supply airflow is identified, the duct system should be designed per ASHRAE or SMACNA guidelines and sized to minimize the duct static pressure at the specified airflow. The design duct static pressure drop at the design airflow is used as part of the unit supply fan selection.

Some unit options, such as the MERV 8 or 13 filters, and high capacity heat, will add to the unit's internal static pressure drop and should be considered as part of the supply fan selection. The base unit static pressure drop (cabinet, evaporator, and hot gas reheat coil, standard filter, standard heat) is built into the fan curve and does not need to be considered as part of the selection external static pressure.

The 48/50LC*H unit should be sized to match the required application airflow and the supply fan power (medium or high static) should be selected to meet the external duct static and option static pressure requirements. Once the supply fan selection is confirmed, the selection of cooling, dehumidification, and heating can proceed.

Cooling and dehumidification

The required cooling and dehumidification system capacity is based on the unit supply airflow (known from above), the required supply air dew point and dry bulb temperatures, and the maximum entering energy content that the unit will be required to condition.

Since dedicated ventilation and MUA systems condition 100% outdoor air, the maximum energy content (latent and sensible) that the cooling circuit will need to condition is based on the geographic location of the application. Unless otherwise indicated, use the .4% or 1% design

evaporation condition from the ASHRAE design condition listing as the maximum energy content when sizing the cooling and dehumidification system.

Finally, when unit cooling and dehumidification capacity needs to be selected to achieve the design supply air dry bulb and dew point temperatures; the supply air dew point temperature will be the same as the evaporator leaving air dew point temperature in cooling mode. The supply air dry bulb temperature will be the same as the hot gas reheat leaving air dry bulb temperature in reheat mode. The supply air dew point and dry bulb temperatures should be provided by the engineer or customer. The supply air dew point will typically match or be slightly lower than the space design dew point temperature (typically <60°F). The supply air dry bulb temperature will typically match or be lower than the space dry bulb temperature (68°F to 74°F).

Heating

The unit heating system sizing is based on the unit supply airflow (known from above), the required dry bulb temperature, and the lowest entering air energy content that the heating system will be required to condition.

Since dedicated ventilation systems condition 100% outdoor air, the minimum energy content that the heating system will need to condition is based on the geographic location of the application. If not otherwise known, it is recommended to use .4% or 1% design heating condition from the ASHRAE design condition listing.

Space air conditioning

The sizing method for space air conditioning units with varying quantities of outdoor air requires extra consideration to ensure that the equipment is properly sized to cover the peak system loads, but not oversized to the point where the unit cannot perform properly during part-load conditions. A modeling program, such as Hourly Analysis Program (HAP) is recommended for assistance with sizing comfort cooling and heating applications with varying quantities of outdoor air.

Consider the following sizing guidelines when selecting 48/50LC*H units into space air conditioning applications.

Supply fan

For space air conditioning applications, the unit supply fan is sized based on the larger of the space comfort cooling and heating airflow or the ventilation/make-up air outdoor airflow requirement. The outdoor airflow is based on the ventilation or make-up air requirement. The space comfort cooling and heating airflow, which is typically the larger of the two airflows, is based on the space cooling and heating loads and the unit supply air temperature at peak load.

Once the supply airflow is identified, the supply and return duct systems should be designed per ASHRAE or SMACNA guidelines and designed to minimize the duct static pressure. The resulting return and supply duct static pressure should be used as part of the unit supply fan selection.

Some equipment options, such as the MERV 8 or 13 filters, and high capacity heat, will add to the unit's internal static pressure drop and should be considered as part of the supply fan selection. The base unit static pressure drop (cabinet, evaporator, and hot gas reheat coil, standard filter, standard heat) is built into the fan curve and does not need to be considered as part of the selection external static pressure.

The 48/50LC*H unit should be sized to match the required application airflow and the supply fan power (medium or high static) should be sized to meet the airflow, external duct static, and option static pressure requirements. Once the supply fan selection is confirmed, the selection of cooling or heating systems can proceed.

Cooling and dehumidification

The cooling and dehumidification system's sizing is based on the unit supply airflow (known from above), the required supply air dew point and dry bulb temperatures, and the maximum entering energy content that the cooling circuit will be required to condition.

Since the comfort space cooling and heating system will be conditioning both outdoor air and space air, the peak mixed air load must be calculated based on the maximum load from the outdoor air and the maximum load from the space air. The peak energy content for outdoor air is typically the ASHRAE design evaporation day, based on the geographic location of the project. The peak energy content for the space return air is based on the maximum internal space loads and any solar or other loads affecting the space.

Finally, when selecting the cooling capacity, the unit needs to be selected to achieve a design supply air dew point and dry bulb temperature leaving the evaporator to properly cool the space at its peak load. The target supply air dew point and dry bulb temperatures should be provided by the engineer or customer. The supply air dew point will typically be lower than the space design dew point temperature (typically <60°F), to allow the unit to offset the space latent load. The supply air dry bulb temperature leaving the unit should be cool (55°F to 60°F).

Heating

The unit heating system sizing is based on the unit supply airflow (known from above), the required dry bulb temperature, and the lowest entering air energy content that the heating system will be required to condition.

Since the comfort space cooling and heating system will be conditioning both outdoor air and space air, the peak mixed air load must be calculated based on the minimum load from the outdoor air and the minimum load from the space air. The minimum energy content for outdoor air is typically the ASHRAE design heating day, based on the geographic location of the project. The minimum energy content for the space return air is based on the internal space loads and any other loads affecting the space.

For applications with field-installed energy recovery ventilators (ERV) and where the outdoor air temperature doesn't drop below freezing (32°F), the heating system can be sized to provide enough heating capacity to heat the air leaving the energy recovery wheel (based on the minimum mixed air temperature entering the energy recovery wheel) up to the required supply air temperature.

If equipment is being sized without a design engineer, the recommended design supply air dry bulb temperature target is 75°F. The unit should not be sized to exceed an 85°F supply air dry point temperature.

For 48/50LC*H units the unit heating capacity can be varied by changing the unit tonnage and unit heater size (low, medium, high for gas, medium, and high for electric) to meet the application requirements.

LC*H quick select

The following quick select guidance can be used for basic selections for 100% outdoor air or space air conditioning systems in Packaged RTU builder. A final selection should be performed based on the application airflow and application conditions before ordering equipment.

Wizard screen/base unit tab

1. Select the unit heat type. Use the 48LC*H for gas heat applications (natural gas or propane). Use the 50LC*H for no heat or electric heat applications.
2. Select the unit tonnage. If the tonnage is unknown but the supply airflow is known, assume 175 cfm/ton for 100% outdoor air units or 300 cfm/ton for mixed air units.
3. Select the unit voltage.
4. Select the application type (ventilation, make-up air, or space air conditioning).

Base unit tab

1. Select the unit heat capacity. If unknown, select low gas heat or medium electric heat for zones 1-3, medium gas heat or high electric heat for zone 4-5, and high gas heat or high electric heat for zones 6-8.
2. Select the supply and return orientation.

FIOPs tab

1. Select the indoor fan motor options, including fan motor static and control. Start with the medium static motor for applications up to 2 in. wg.
2. Select any other factor-installed options that are needed. It is important to consider options that may increase the static that the supply fan will need to overcome, such as higher-grade filters.

Accessories, warranty and start-up, and blanket quote tabs

Design criteria tab

1. Enter the altitude. Altitude must be considered for high elevation applications.
2. Determine the supply fan external duct static pressure. If unknown, assume 1 in. wg for 100% outdoor air systems or 1-1/2 in. wg for mixed air systems.
3. Enter the supply fan airflow. If the airflow isn't known, but the unit tonnage is, assume 75 cfm/ton for 100% outdoor air units without energy recovery, 225 cfm/ton for 100% outdoor air units or 300 cfm/ton for mixed air units.
4. Specify the selection coil conditions for cooling and heating.

If the conditions are unknown, lookup the design evaporation day and heating day conditions for the project location for 100% outdoor air applications. For mixed air applications, use calculate coil conditions function by entering the outdoor airflow and outdoor air and return air conditions.

NOTE: the builder geographic lookup tables only includes design cooling and heating day conditions. For high outdoor air applications, use design evaporation day instead of design cooling for cooling and dehumidification sizing.

5. For energy recovery applications, enter the return air cooling and heating dry bulb and wet bulb temperatures. If unknown, use the default builder temperatures.
6. Enter the outdoor air entering condenser coil temperature. If unknown, use the design evaporation day dry bulb.

Performance

1. Review any error messages. Adjust as needed.
2. Review the cooling and dehumidification performance. Verify that the evaporator leaving air temperature meets project requirements. If unknown, target an evaporator leaving air temperature of no higher than 60°F and no lower than 50°F. Verify that the hot gas reheat leaving air temperature meets project requirements. The builder shows HGRH (hot gas reheat) performance at 20% reheat output, so additional reheat performance is available. Reselect as necessary by changing the unit tonnage or by adjusting the airflow or entering air temperatures.
3. Review the heating performance. Verify that the heat leaving air temperature meets project requirements. If unknown, target a heating leaving air temperature is no lower than 65°F, and no higher than 95°F. Reselect as necessary by changing the unit tonnage, heat capacity, or by adjusting the airflow or entering air temperatures.

Factory-installed option guidance

Consider the following options when selecting 48/50LC*H units:

High Turndown Heat (10:1 Natural Gas/6:1 Propane)

The high turndown heat option is recommended for high-temperature rise (>75°F) applications or heat tempered venting/cooling applications with natural gas heat. The 10% minimum turndown capability of the 10:1 natural gas furnace allows for improved supply air temperature control at low load conditions, compared to the standard furnace.

The high turndown heat option is also recommended for medium (>50°F) or high-temperature rise (>75°F) applications or heat tempered venting/cooling applications with propane heat. The 17% minimum turndown capability of the 6:1 propane furnace allows for improved supply air temperature control at low load conditions, compared to the standard furnace.

Duct pressure control

The supply duct pressure supply fan control option is used for modulating ventilation applications with variable ventilation volume air terminal units. As the air terminal unit damper position is modulated based on space occupancy or space CO₂ levels, the unit supply fan will modulate the volume of air delivered to the duct system based on static pressure.

The duct pressure option is also recommended for constant volume applications to accommodate for filter loading. Even as filters become dirty and have a higher static pressure drop, the supply fan will modulate to maintain a constant supply duct static pressure and deliver a constant volume of air to the duct.

Zone pressure control

The zone pressure supply fan control option is recommended for applications with variable volumes of space exhaust, including single spaces with modulating exhaust fans, single spaces with multiple exhaust fans that operate independently, or for buildings with multiple, independently operating exhaust fans.

E-coated condenser and evaporator

The e-coated condenser and evaporator options are required for applications with environments that are corrosive to the aluminum/copper (Al/Cu) condenser, evaporator, and hot gas reheat coils, such as coastal applications. For 100% outdoor air applications in corrosive environments, it's recommended to provide a coating on both the evaporator and condenser coils, instead of just on the condenser coils.

Hail Guard

The hail guard option can be used to protect the condenser coil from damage from hail in climates that experience frequent hail storms. The hail guards are also recommended to protect the condenser coil from damage where the unit is installed around people and activities, such as ground-level installations.

Low-leak economizer

For 100% outdoor air applications without a field-provided outdoor air intake, the factory-installed low leak economizer assembly is required.

4 in. MERV 8 filter

The 4 in. MERV 8 filter option is recommended to provide energy savings in applications requesting MERV 8 filters. A 4 in. MERV 8 filter will typically have a lower initial airside pressure drop than a 2 in. MERV 8 filter, which saves on supply fan energy.

4 in. MERV 13 filter

The 4 in. MERV 13 filter option is recommended for applications requiring a high filter rating (MERV) to support high indoor air quality. MERV 13 filters can also be required by some building codes.

Double wall construction

The double wall construction option is recommended for applications requiring better wipe-down cleaning capability than the standard foil-faced fiberglass insulation.

Note about this specification:

This specification is in the "Masterformat" as published by the Construction Specification Institute. Please feel free to copy this specification directly into your building spec.

WeatherExpert® High Outdoor Air Gas Heat/Electric Cooling Packaged Rooftop

HVAC Guide Specifications:

Size Range: 6 to 10 Nominal Tons

Carrier Model Number: 48LC*H

Part 1 — 23 06 80 Schedules for Decentralized HVAC Equipment

1.01 23 06 80.13 Decentralized Unitary HVAC Equipment Schedule

A. 23 06 80.13.A. Rooftop unit schedule

1. Schedule is per the project specification requirements.

Part 2 — 23 07 16 HVAC Equipment Insulation

2.01 23 07 16.13 Decentralized, Rooftop Units:

A. 23 07 16.13.A. Indoor fan compartment:

1. Interior cabinet surfaces shall be insulated with a minimum 1/2 in. thick, minimum 1-1/2 lb density aluminum foil-faced insulation on the air side.
2. Insulation and adhesive shall meet NFPA 90A requirements for flame spread and smoke generation.
3. Unit internal insulation linings shall be resistant to mold growth in accordance with "mold growth and humidity" test in ASTM C1338, G21, and UL 181 or comparable test method. Air stream surfaces shall be evaluated in accordance with the "Erosion Test" in UL 181, as part of ASTM C1071.

B. 23 07 16.13.B. Gas heat compartment:

1. Aluminum foil-faced fiberglass insulation shall be used.
2. Insulation and adhesive shall meet NFPA 90A requirements for flame spread and smoke generation.

Part 3 — 23 09 13 Instrumentation and Control Devices for HVAC

3.01 23 09 13.23 Sensors and Transmitters:

A. 23 09 13.23.A Thermostats:

1. Thermostat *must*:
 - a. Have capability to energize two different stages of cooling and two different stages of heating.
2. Thermostat *may*:
 - a. Energize both "Y" and "G" when calling for cooling.
 - b. Energize both "H" and "G" when calling for dehumidification.
 - c. Energize "G" when calling for venting.

B. 23 09 13.23.B. Sensors/Switches:

1. The unit shall include the following sensors/switches as factory-installed:
 - a. Return air temperature
 - b. Return air relative humidity
 - c. Outdoor air temperature
 - d. Outdoor air relative humidity
 - e. Refrigerant circuit discharge pressure
 - f. Refrigerant circuit suction pressure
 - g. Refrigerant circuit high pressure switch
 - h. Condensate over flow switch
2. The unit shall include the following sensors as factory provided, field-installed:
 - a. Supply air temperature

Part 4 — 23 09 23 Direct Digital Control (DDC) System for HVAC

4.01 23 09 23.13 Decentralized, Rooftop Units:

A. 23 09 23.13.A. Carrier SmartVu™ integrated Direct Digital Control (DDC) shall:

1. Include a factory-installed, color, touchscreen control interface that is factory wired and mounted in the unit control panel and is no less than 6.75 in. diagonally and has an environmental range of -4°F (-20°C) to 158°F (70°C), non-condensing.
 - a. The control interface *must*:
 - 1) Include an easy to understand menu with icon based navigation.
 - 2) Include a combination of graphical and text based screen for status.
 - 3) Include light colored backgrounds on screens. Black or dark gray backgrounds are not acceptable, due to poor visibility in daylight.
2. Have no less than 3 levels of user access with password protection, including basic access without password, password protected user access, and password protecting service access.
3. Provide sensor/switch support for the factory-installed sensor/switches listed in Part 3, 23 09 13.23.B. Sensors/Switches, as well as the following field-installed sensor/switches:
 - a. Return air CO₂
 - b. Return or supply air smoke detector
 - c. Supply duct static pressure
 - d. Building static pressure
 - e. Space temperature
 - f. Space relative humidity
 - g. Space CO₂
 - h. Mixed air temperature
 - i. Pre-filter status switch
 - j. Phase monitor

4. Provide support for the following field-provided control inputs:
 - a. 2-stage heat/cool thermostat (Y1, Y2, W1, W2, G)
 - b. Humidistat or thermostat dehumidification output (H)
 - c. Third-party outdoor air damper modulation (4-20mA)
 - d. Third-party indoor fan modulation (4-20mA)
 - e. Third-party exhaust fan modulation (4-20mA)
 - f. Remote shutdown/occupancy switch
 - g. Fire shutdown
5. Provide the following field use control outputs:
 - a. Alarm indicator
 - b. Damper override relay (heat, dehumidification, and per-occupancy operation)
6. Be capable of fully stand-alone, 2-stage heat/cool thermostat, third-party DDC input control, or networked operation.
7. Provide control configurations for the following occupancy sources:
 - a. Local schedule
 - b. Occupancy switch
 - c. Network occupancy input
8. Provide network communication compatibility with the following protocols:
 - a. Carrier Comfort Network[®] (CCN)
 - b. BACnet MS/TP
 - c. BACnet IP
9. Establish demand for cooling or heating based on occupancy status, a demand source type, and the source temperature. The control must:
 - a. Provide configurations for the following cooling/heating demand sources:
 - 1) Space temperature
 - 2) Outdoor air temperature
 - 3) Thermostat or third-party switch inputs
 - b. Limit control setpoints, settings and configurations based on the demand source configuration.
 - c. Provide configurations to disable heating and cooling during the unoccupied period.
 - d. Provide user configurable temperature setpoints for the occupied and unoccupied periods, if allowed by the demand source.
 - e. Provide a user configurable supply air temperature setpoint for each demand.
10. Select a cooling or heating mode based on the supply air temperature setpoint established by the cooling or heating demand, the measured or calculated mixed air temperature, the unit configuration, the control settings, and cooling and heating system availability. The control must:
 - a. Operate the cooling or heating systems based on the supply air temperature setpoints established by the heating/cooling demand.
 - b. Provide a user configurable compressor lockouts based on outdoor air temperature and mixed air temperature.
 - c. Provide a user configurable heating lockout based on outdoor air temperature.
11. Establish a demand for dehumidification based on occupancy status, a demand source, and the source humidity. The control must:
 - a. Provide configurations to prevent dehumidification in the unoccupied period.
 - b. Provide configurations for the following dehumidification demand sources:
 - 1) Space relative humidity
 - 2) Return air relative humidity
 - 3) Outdoor air dewpoint
 - 4) Humidistat, thermostat dehumidify switch, or third-party switch input
12. Select a dehumidification mode depending on the cooling coil temperature control from the dehumidification demand, the supply air temperature control point from the cooling or ventilation demand, the unit configuration, the control settings, and the dehumidification system availability. The control must:
 - a. Operate the cooling systems based on the cooling coil temperature setpoint established by the dehumidification demand and operate the hot gas reheat system based on the supply air temperature setpoint established by the cooling or ventilation demand.
13. Provide operation of the indoor fan:
 - a. Provide the following indoor fan speed control configurations, depending on the unit configuration and cooling/heating demand source:
 - 1) Constant speed
 - 2) Staged speeds based on demand (staged air volume, SAV[™])
 - 3) Variable speeds based on duct static pressure
 - 4) Variable speed based on building static pressure
14. Provide operation of the unit exhaust fan (if equipped):
 - a. Provide the following exhaust fan speed control configurations, depending on the unit configuration:
 - 1) 2-speeds based on outdoor air damper position
 - 2) Variable speeds based on building pressure

15. Provide operation of the outdoor air damper (if equipped):
 - a. Provide outdoor air damper fault detection and diagnostics (FDD) in accordance with California Title 24 and ASHRAE 90.1 requirements, if allowed by the demand source.
 - b. Provide configurations to disable free cooling with outdoor air based on the following:
 - 1) Outdoor air temperature
 - 2) Outdoor air enthalpy, outdoor air vs. return air enthalpy, or outdoor air vs. return air temperature
 - 3) Outdoor air dewpoint
 - c. Provide configurations to operate the outdoor air damper position based on:
 - 1) Two-position (closed and 100% OA)
 - 2) Indoor speed mapping
 - 3) A third-party control signal
16. Provide the following alarm capability:
 - 1) Display current active alarm on the home screen.
 - 2) Record the time and date of alarms.
 - 3) Provide an alarm history of the latest 50 alarms.
17. Provide the following service capability:
 - a. Display the refrigerant suction and discharge pressure sensor readings on the control interface and over network points, without the need for field provided gauges.
 - b. Allow trending of unit temperature, pressures, and statuses and display trends on the control interface.
 - c. Include a component test mode to allow testing of individual components (if equipped), including the indoor fan, condenser fans, exhaust fan, outdoor air damper.
 - d. Include a service run mode to allow testing of unit systems, including the cooling system, heating system, reheat system..
 - e. Record run hours and starts for key components, such as compressors, the Indoor fan, and heating system.

Part 5 — 23 09 33 Low Voltage Control for HVAC Units

- 5.01 23 09 33.13 Decentralized, Rooftop Units:
 - A. 23 09 33.13.A. General:
 1. Shall be complete with self-contained low-voltage control circuit protected by a resettable circuit breaker on the 24-v transformer side. Transformer shall have 75VA capability.
 2. Shall utilize color-coded wiring.
 3. Shall include a control and power wiring diagram affixed to the control panel door.

4. Heating section shall be provided with the following minimum protections:
 - a. High-temperature limit switches
 - b. Induced draft motor pressure switch
 - c. Flame rollout switch
 - d. Flame proving controls

Part 6 — 23 09 93 Sequence of Operations for HVAC Controls

- 6.01 23 09 93.13 Decentralized, Rooftop Units:
 - A. 23 09 93.13.A. INSERT SEQUENCE OF OPERATION

Part 7 — 23 40 13 Panel Air Filters

- 7.01 23 40 13.13 Decentralized, Rooftop Units:
 - A. 23 40 13.13.A. Standard filter section:
 1. Shall consist of factory-installed, low velocity, throwaway 2 in. thick fiberglass construction filters of commercially available sizes.
 2. Filters shall be accessible through an access panel with “no-tool” removal as described in the unit cabinet section of this specification (See Part 8 — 23 81 19.13.G).

Part 8 — 23 81 19 Self-Contained Air Conditioners

- 8.01 23 81 19.13 Small-Capacity Self-Contained Air Conditioners (48LC*H 07-12):
 - A. 23 81 19.13.A. General:
 1. Outdoor, rooftop mounted, ISC electrically controlled, heating and cooling unit utilizing fully hermetic scroll compressors for cooling duty and gas combustion heat for heating duty.
 2. Factory assembled, single-piece heating and cooling rooftop unit. Contained within the unit enclosure shall be all factory wiring, piping, controls, and special features required prior to field start-up.
 3. Unit shall use Puron® (R-401A) refrigerant.
 4. Unit shall be installed in accordance with the manufacturer’s instructions.
 5. Unit must be selected and installed in compliance with local, state, and federal codes.
 - B. 23 81 19.13.B. Quality Assurance:
 1. Unit meets and exceeds ASHRAE 90.1-2013 minimum efficiency requirements.
 2. Unit shall be rated in accordance with AHRI Standards 340/360.
 3. Unit shall be designed to conform to ASHRAE 15, 2001.
 4. Unit shall be ETL/UL-tested and certified in accordance with ANSI Z21.47 Standards and UL-listed and certified under Canadian standards as a total package for safety requirements.
 5. Insulation and adhesive shall meet NFPA 90A requirements for flame spread and smoke generation.

6. Unit internal insulation linings shall be resistant to mold growth in accordance with “mold growth and humidity” test in ASTM C1338, G21, and UL 181 or comparable test method. Air stream surfaces shall be evaluated in accordance with the “Erosion Test” in UL 181, as part of ASTM C1071.
 7. Unit casing shall be capable of withstanding 500 hour salt spray exposure per ASTM B117 (scribed specimen).
 8. Roof curb shall be designed to conform to NRCA Standards.
 9. Unit shall be subjected to a completely automated run test on the assembly line. The data for each unit will be stored at the factory, and must be available upon request.
 10. Unit shall be designed in accordance with UL Standard 1995, including tested to withstand rain.
 11. Unit shall be constructed to prevent intrusion of snow and tested to prevent snow intrusion into the control box up to 40 mph.
 12. Unit shake tested to assurance level 1, ASTM D4169 to ensure shipping reliability.
 13. High-Efficiency Motors listed shall meet section 313 of the Energy Independence and Security Act of 2007 (EISA 2007).
- C. 23 81 19.13.C. Delivery, Storage, and Handling:
1. Unit shall be stored and handled per manufacturer’s recommendations.
 2. Lifted by crane requires either shipping top panel or spreader bars.
 3. Unit shall only be stored or positioned in the upright position.
- D. 23 81 19.13.D. Project Conditions:
1. As specified in the contract.
- E. 23 81 19.13.E. Operating Characteristics:
1. Unit shall be capable of starting and running at 125°F (51.6°C) ambient outdoor temperature, meeting maximum load criteria of AHRI Standard 340/360 at ±10% voltage.
 2. Compressor with standard controls shall be capable of operation down to 40°F (4°C) ambient outdoor temperatures. Low ambient cooling operation may be additional limited by entering air conditions.
 3. Unit shall discharge supply air vertically or horizontally as shown on contract drawings.
 4. Unit shall be factory configured for vertical supply and return configurations.
 5. Unit shall be field convertible from vertical to horizontal airflow on all models. No special kit required on 07 size models. Field-installed supply duct kit required for 08-12 size models only.
6. Unit shall be capable of mixed operation: vertical supply with horizontal return or horizontal supply with vertical return.
- F. 23 81 19.13.F. Electrical Requirements:
1. Main power supply voltage, phase, and frequency must match those required by the manufacturer.
- G. 23 81 19.13.G. Unit Cabinet:
1. Unit cabinet shall be constructed of galvanized steel, and shall be bonderized and coated with a pre-painted baked enamel finish on all externally exposed surfaces.
 2. Unit cabinet exterior paint shall be:
Film thickness, (dry) 0.003 inches minimum, gloss (per ASTM D523, 60°F / 16°C): 60, Hardness: H-2H Pencil hardness.
 3. Indoor fan compartment interior cabinet insulation shall conform to AHRI Standards 340/360 minimum exterior sweat criteria. Interior surfaces shall be insulated with a minimum 1/2 in. thick, 1 lb density, aluminum foil-faced fiberglass insulation. Aluminum foil-faced fiberglass insulation shall also be used in the heat compartment.
 4. Unit internal insulation linings shall be resistant to mold growth in accordance with “mold growth and humidity” test in ASTM C1338, G21, and UL 181 or comparable test method. Air stream surfaces shall be evaluated in accordance with the “Erosion Test” in UL 181, as part of ASTM C1071.
 5. Base Rail:
 - a. Unit shall have base rails on a minimum of 4 sides.
 - b. Holes shall be provided in the base rails for rigging shackles to facilitate maneuvering and overhead rigging.
 - c. Holes shall be provided in the base rail for moving the rooftop by fork truck.
 - d. Base rail shall be a minimum of 16 gauge thickness.
 6. Condensate Pan and Connections:
 - a. Shall be an internally sloped condensate drain pan made of a non-corrosive material.
 - b. Shall comply with ASHRAE Standard 62.
 - c. Shall use a 3/4 in. –14 NPT drain connection, possible either through the bottom or side of the drain pan. Connection shall be made per manufacturer’s recommendations.
 7. Top Panel:
 - a. Shall be a single piece top panel on 07 sizes, two piece top on 08-12 sizes.
 8. Gas Connections:
 - a. All gas piping connecting to unit gas valve shall enter the unit cabinet at a single location on side of unit (horizontal plane).

- b. All gas heater condensate piping shall exist in the unit through a single location on the side of the unit (horizontal plane).
- c. Thru-the-base capability:
 - 1) Standard unit shall have a thru-the-base gas-line location using a raised, embossed portion of the unit basepan.
 - 2) Optional, factory-approved, water-tight connection method must be used for thru-the-base gas connections.
 - 3) No basepan penetration, other than those authorized by the manufacturer, is permitted.
- 9. Electrical Connections:
 - a. All unit power wiring shall enter unit cabinet at a single, factory-prepared, knockout location.
 - b. Thru-the-base capability:
 - 1) Standard unit shall have a thru-the-base electrical location(s) using a raised, embossed portion of the unit basepan.
 - 2) Optional, factory-approved, water-tight connection method must be used for thru-the-base electrical connections.
 - 3) No basepan penetration, other than those authorized by the manufacturer, is permitted.
- 10. Component Access Panels (standard):
 - a. Cabinet panels shall be easily removable for servicing.
 - b. Unit shall have one factory installed, tool-less, removable, filter access panel.
 - c. Panels covering control box, indoor fan, indoor fan motor, gas components (where applicable), and compressors shall have a molded composite handles.
 - d. Handles shall be UV modified, composite, permanently attached, and recessed into the panel.
 - e. Screws on the vertical portion of all removable access panel shall engage into heat resistant, molded composite collars.
 - f. Panels covering the control box, filter, fan motor, and compressor shall be hinged and include quarter turn latches.
 - g. Collars shall be removable and easily replaceable using manufacturer recommended parts.
- H. 23 81 19.13.H. Standard Turndown Gas Heat:
 - 1. General:
 - a. The gas heater shall be factory-installed and configured for natural gas. The heater shall:
 - 1) Include a single point gas connection
 - 2) Gas supply pressure at the inlet to the gas valve must match that required by the manufacturer.
 - 3) Include a single, modulating control valve capable of 5:1 turndown modulating with natural gas or 3:1 with liquid propane.
 - 4) Provide operation up to 2000 ft. in elevation.
 - 5) High elevation accessory kits must be available for elevations up to 7000 ft.
 - 6) Allow field conversion to liquid propane (LP) using an accessory kit.
 - b. The heat exchanger shall be an induced draft design. Positive pressure heat exchanger designs shall not be allowed.
 - 1) Inducer operation shall be verified by pressure switch.
 - 2) The heat exchanger material shall be constructed of type 409 stainless steel. Aluminized steel heat exchangers are not allowed.
 - c. Include an self-contained ignition control module with direct-spark ignition system.
 - 1) The ignition control module shall monitor heater safeties and provide LED fault detection indication.
 - 2) Ignition control modules shall include an alarm output, allowing heater alarm status to be indicated on the SmartVu display.
 - d. Include a flue gas condensate drain connection for field provided condensate trap and drain.
- I. 23 81 19.13.I. Coils:
 - 1. Standard Aluminum Fin/Copper Tube Coils:
 - a. Standard evaporator, hot gas reheat, and condenser coils shall have aluminum lanced plate fins mechanically bonded to seamless internally grooved 5/16 in. diameter copper tubes with all joints brazed.
 - b. Evaporator coils shall be leak tested to 150 psig, pressure tested to 450 psig, and qualified to UL 1995 burst test at 1775 psig.
 - c. Condenser coils shall be leak tested to 150 psig, pressure tested to 650 psig, and qualified to UL 1995 burst test at 1980 psig.
- J. 23 81 19.13.J. Refrigerant Components:
 - 1. Refrigerant circuit shall include the following control, safety, and maintenance features:
 - a. Thermostatic Expansion Valve (TXV) shall help provide optimum performance across the entire operating range. Shall contain removable power element to allow change out of power element and bulb without removing the valve body.
 - b. Refrigerant filter drier – Solid core design.
 - c. Service gauge connections on suction and discharge lines.

- d. Single circuit design with tandem compressor and fully activated evaporator coil.
 - 1) Fully modulating low load protection valve that reduces the effective system capacity by redirecting discharge gas into the suction inlet.
 - 2) 2-position low load protection valves, such as hot gas bypass or suction shut off valves are not acceptable.
 - 3) Low load protection valves that direct discharge gas into the evaporator are not acceptable.
 - 4) Fully modulating, three-way hot gas reheat valve that directs discharge gas between the condenser and the hot gas reheat coil. On/off or two-position hot gas reheat valves are not acceptable.
 - a) If the hot gas reheat valve shall periodically modulate its highest hot gas reheat output to purge oil that may be entrapped in the hot gas reheat coil.
- 2. Compressors:
 - a. Models shall use a minimum of two fully hermetic scroll compressors in a tandem compressor configuration. Single compressor models are not acceptable.
 - b. Models shall be available with a single refrigerant circuit and a minimum of three stages cooling operation.
 - 1) The compressor shall be capable of operating for a minimum of 2-1/2 hours at its lowest stage of operation without the need to increase compressor capacity or speed for the purposes of oil return.
 - 2) Models that include inverter or variable frequency drive compressors shall include an isolation transformer.
 - c. Compressor motors shall be cooled by refrigerant gas passing through motor windings.
 - 1) Models that include inverter or variable frequency drive compressors shall also include a refrigerant cooled inverter or VFD.
 - d. Compressors shall be internally protected from high discharge temperature conditions.
 - e. Compressors shall be protected from an over-temperature and over-ampereage conditions by an internal, motor overload device.
 - f. Compressor shall be factory mounted on rubber grommets.
 - g. Compressor motors shall have internal line break thermal, current overload and high-pressure differential protection.
 - h. Crankcase heater shall be standard on each compressor and deactivated whenever the compressor is in operation.
- K. 23 81 19.13.K. Filter Section:
 - 1. Filters access is specified in the unit cabinet section of this specification.
 - 2. Filters shall be held in place by a pivoting filter tray, facilitating easy removal and installation.
 - 3. Shall consist of factory-installed, low velocity, throw-away 2 in. thick fiberglass construction filters.
 - 4. Filters shall be standard, commercially available sizes.
 - 5. Only one size filter per unit is allowed.
- L. 23 81 19.13.L. Indoor Fan and Motor with EcoBlue™ Technology:
 - 1. Direct Drive Indoor Fan Motor:
 - a. Shall have permanently lubricated bearings.
 - b. Shall have inherent automatic-reset thermal overload protection.
 - c. Shall be an electronically commutated motor (ECM).
 - d. Shall have slow ramp up to speed capabilities.
 - e. Shall not include a belt or sheave system.
 - f. Shall be internally protected from electrical phase reversal and loss.
 - g. Motor speed setup and control setup shall be accomplished using the SmartVu™ control.
 - h. Medium static motor option shall include a minimum 2.4 HP motor and provide up to 2 in. wg external static capability at up to 350 cfm/ton.
 - 2. Indoor Fan:
 - a. Speed control shall be easily setup from the SmartVu control interface. Control configurations shall include:
 - 1) Staged Air Volume (SAV™)
 - 2) Constant volume
 - 3) Variable Air Volume (VAV) duct pressure control
 - 4) Variable Air Volume (VAV) space pressure control
 - 5) Third-party input control
 - b. Shall be a vane axial fan design with 75% less moving parts than a conventional belt drive system.
 - c. Shall be constructed of a cast aluminum stator and high impact composite material on rotor and air inlet casing.
 - d. Shall be patented/patent pending design with a corrosion resistant material and dynamically balanced.

- e. Shall have slow ramp up to speed capabilities to help reduce sound and comfort issues typically associated with single speed belt drive systems.
 - f. Shall be a slide out design with simple screw removal.
 - g. Fans shall be capable of operating up to 350 cfm/tons.
 - h. Fans shall be capable of operating down to 130 cfm/tons.
- M. 23 81 19.13.M. Condenser Fans and Motors:
- 1. Condenser Fan Motors:
 - a. Shall be a totally enclosed, multi speed ECM motor.
 - b. Shall use permanently lubricated bearings.
 - c. Shall have inherent thermal overload protection with an automatic reset feature.
 - d. Shall use a shaft-down design on 07 size models and shaft-up on 08-12 size models with rain shield.
 - 2. Condenser Fans:
 - a. Shall be a direct-driven propeller type fan.
 - b. Shall have galvanized aluminum (galvalum) blades riveted to corrosion-resistant steel spindlers and shall be dynamically balanced.
- N. 23 81 19.13.N. Special Features Options and Accessories:
- 1. High Turndown Gas Heat (factory-installed):
 - a. The unit shall include a factory-installed gas heater with one modulating control valve and one 2-stage control valve.
 - b. The natural gas heater shall be capable of modulating down to 10% of its nominal rated input capacity.
 - 2. High Static Indoor Fan Motor (factory-installed):
 - a. Shall include a minimum 5 HP motor and provide up to 3 in. wg external static capability at up to 350 cfm/ton.
 - 3. Duct Pressure Control:
 - a. Shall include a factory-installed duct pressure transducer for indoor fan speed modulation based on duct static pressure.
 - b. Pneumatic tubing and pressure pickup port are field-supplied.
 - 4. Zone Static Pressure Control:
 - a. Shall include a factory-installed building static pressure transducer for indoor fan speed modulation based on zone static pressure.
 - b. Pneumatic tubing and pressure pickup port are field-supplied.
 - 5. Pre-coated aluminum-fin condenser coils:
 - a. Shall have a durable epoxy-phenolic coating to provide protection in mildly corrosive coastal environments.
 - b. Coating shall be applied to the aluminum fin stock prior to the fin stamping process to create an inert barrier between the aluminum fin and copper tube.
 - c. Epoxy-phenolic barrier shall minimize galvanic action between dissimilar metals.
 - d. Corrosion durability of fin stock shall be confirmed through testing to be no less than 1000 hours salt spray per ASTM B117-90.
 - e. Corrosion durability of fin stock shall be confirmed through testing to have no visible corrosion after 48 hour immersion in a room temperature solution of 5% salt, 1% acetic acid.
 - f. Fin stock coating shall pass 2000 hours of the following:
 - 1) one week exposure in the prohesion chamber followed by one week of accelerated ultraviolet light testing.
 - a) Prohesion chamber: the solution shall contain 3.5% sodium chloride and 0.35% ammonium sulfate. The exposure cycle is one hour of salt fog application at ambient followed by one hour drying at 95°F (35°C).
 - 6. Optional e-coated aluminum-fin indoor air and/or condenser coils:
 - a. Shall be available as factory-installed on the indoor air coils (evaporator and hot gas reheat) and or condenser coils.
 - b. Shall have a flexible epoxy polymer coating uniformly applied to all coil surface areas without material bridging between fins.
 - c. Coating process shall ensure complete coil encapsulation of tubes, fins and headers.
 - d. Color shall be high gloss black with gloss per ASTM D523-89.
 - e. Uniform dry film thickness from 0.8 to 1.2 mil on all surface areas including fin edges.
 - f. Superior hardness characteristics of 2H per ASTM D3363-92A and cross-hatch adhesion of 4B-5B per ASTM D3359-93.
 - g. Impact resistance shall be up to 160 in.-lb (ASTM D2794-93).
 - h. Humidity and water immersion resistance shall be up to minimum 1000 and 250 hours respectively (ASTM D2247-92 and ASTM D870-92).
 - i. Corrosion durability shall be confirmed through testing to be no less than 6000 hours salt spray per ASTM B117-90.

7. Condenser Coil Hail Guard Assembly (factory or field-installed):
 - a. Shall protect against damage from hail.
 - b. Shall be louvered design.
8. Ultra-Low Leak Economizers (factory or field-installed) :
 - a. Available as a factory-installed option (vertical only) or field-installed accessory (vertical or horizontal) on most models.
 - b. Ultra-Low Leak economizer dampers meet California's Title 24 section 140.4 prescriptive requirements for leakage, reliability testing, etc., and ASHRAE 90.1-2013 requirements for damper leakage.
 - c. Economizers are available with EconoMi\$er®2 controls for SmartVu units.
 - d. Integrated, gear driven opposed blade design type capable of simultaneous economizer and compressor operation.
 - e. Damper blades shall be galvanized steel with composite gears. Plastic or composite blades on intake or return shall not be acceptable.
 - f. Shall be equipped with gear driven dampers for both the outdoor ventilation air and the return air for positive air stream control.
 - g. Shall be capable of introducing up to 100% outdoor air.
 - h. Economizer's barometric relief dampers shall be sized to allow up to 100% relief (actual results will be based on specific job conditions).
9. EconoMi\$er2 Economizer Controls:
 - a. For use with factory-installed (vertical only) or field-installed accessory (vertical or horizontal) on all SmartVu units.
 - b. EconoMi\$er2 economizers are controlled by SmartVu, which shall be 4 to 20mA design.
 - c. SmartVu controls meet California's Title 24 section 120.2 mandatory requirements for economizer Fault Detection and Diagnosis.
 - d. The control shall include all sensors to provide free cooling economizer operation based on dry bulb, enthalpy, differential dry bulb, or differential enthalpy changeover control and dewpoint cutoff.
 - e. Shall be designed to spring return close outside air damper during loss of power.
 - f. Actuator shall be direct coupled to economizer gear. No linkage arms or control rods shall be acceptable.
 - g. The economizer position shall be modulated to maintain minimum airflow into the building during occupied period based on control configuration.
 - h. Controller shall drive outside air dampers completely closed when the unit is in the unoccupied period.
10. Unit-Mounted, Non-Fused Disconnect Switch (factory-installed):
 - a. Switch shall be factory-installed, internally mounted.
 - b. National Electric Code (NEC) and ETL/UL approved non-fused switch shall provide unit power shutoff.
 - c. Shall be accessible from outside the unit.
 - d. Shall provide local shutdown and lockout capability.
 - e. Sized only for the unit as ordered from the factory. Does not accommodate field-installed devices.
11. HACR Breaker (factory-installed):
 - a. These manual reset devices provide overload and short circuit protection for the unit. Factory wired and mounted with the units, with access cover to help provide environmental protection. On 575-v applications, HACR breaker can only be used with WYE power distribution systems. Use on Delta power distribution systems is prohibited.
 - b. Sized only for the unit as ordered from the factory. Does not accommodate field-installed devices.
12. Convenience Outlet (factory-installed):
 - a. Powered convenience outlet:
 - 1) Outlet shall be powered from main line power to the rooftop unit.
 - 2) Outlet shall be powered from line side or load side of disconnect by installing contractor, as required by code. If outlet is powered from load side of disconnect, unit electrical ratings shall be ETL/UL certified and rated for additional outlet amperage.
 - 3) Outlet shall be factory-installed and internally mounted with easily accessible 115-v female receptacle.
 - 4) Outlet shall include 15 amp GFI receptacles with independent fuse protection.
 - 5) Voltage required to operate convenience outlet shall be provided by a factory-installed step-down transformer.
 - 6) Outlet shall be accessible from outside the unit.
 - 7) Outlet shall include a field-installed "Wet in Use" cover.
 - b. Non-powered convenience outlet:
 - 1) Outlet shall be powered from a separate 115/120-v power source.
 - 2) A transformer shall not be included.
 - 3) Outlet shall be factory-installed and internally mounted with easily accessible 115-v female receptacle.

- 4) Outlet shall include 15 amp GFI receptacles with independent fuse protection.
 - 5) Outlet shall be accessible from outside the unit.
 - 6) Outlet shall include a field-installed “Wet in Use” cover.
13. Roof Curbs (Field-installed):
- a. Full perimeter roof curb with exhaust capability providing separate air streams for energy recovery from the exhaust air without supply air contamination.
 - b. Formed galvanized steel with wood nailer strip and shall be capable of supporting entire unit weight.
 - c. Permits installation and securing of ductwork to curb prior to mounting unit on the curb.
14. Thru-the-Bottom Utility Connectors (factory or field installed):
- a. Kit shall provide connectors to permit electrical and gas connections to be brought to the unit through the basepan.
15. Indoor Air Quality (CO₂) Sensor:
- a. Shall be able to provide demand ventilation indoor air quality (IAQ) control.
 - b. The IAQ sensor shall be available in duct mount, wall mount, or wall mount with LED display. The setpoint shall have adjustment capability.
16. Smoke Detectors (factory or field installed):
- a. Shall be a four-wire controller and detector.
 - b. Shall be environmental compensated with differential sensing for reliable, stable, and drift-free sensitivity.
 - c. Shall use magnet-activated test/reset sensor switches.
 - d. Shall have tool-less connection terminal access.
 - e. Shall have a recessed momentary switch for testing and resetting the detector.
 - f. Controller shall include:
 - 1) One set of normally open alarm initiation contacts for connection to an initiating device circuit on a fire alarm control panel.
 - 2) Two Form-C auxiliary alarm relays for interface with rooftop unit or other equipment.
- 3) One Form-C supervision (trouble) relay to control the operation of the Trouble LED on a remote test/reset station.
 - 4) Capable of direct connection to two individual detector modules.
 - 5) Can be wired to up to 14 other duct smoke detectors for multiple fan shutdown applications.
17. Horn/Strobe Annunciator (field-installed):
- a. Provides an audible/visual signaling device for use with factory-installed option or field-installed accessory smoke detectors.
 - 1) Requires installation of a field-supplied 24-v transformer suitable for 4.2 VA (AC) or 3.0 VA (DC) per horn/strobe accessory.
 - 2) Requires field-supplied electrical box, North American 1-gang box, 2 in. (51 mm) x 4 in. (102 mm).
 - 3) Shall have a clear colored lens.
18. Double Wall Construction (factory-installed):
- a. The indoor air touching sections of the unit interior, including top, sides, and base pan, shall be covered with a galvanized steel liner over the R4 foil faced fiberglass insulation
19. Supply Duct Kit (field-installed):
- a. On 08-12 models, a supply air duct cover kit is required when field converting the factory standard vertical duct supply to horizontal duct supply configuration. One required per unit.
20. 4 in. Filter Rack (factory or field installed):
- a. Shall include a field or factory installed filter rack that accepts nominal 4 in. filters.
 - b. Shall include factory or field installed nominal 4 in. MERV 8 filters.
 - c. Shall include factory or field installed nominal 4 in. MERV 13 filters.
21. Propane Conversion Kit (field-installed):
- a. Package shall contain all the necessary hardware and instructions to convert a standard natural gas unit for use with liquefied propane, up to 7000 ft (2134 m) elevation.
22. High Altitude Gas Conversion Kit (field-installed):
- a. Package shall contain all the necessary hardware and instructions to convert a standard natural gas unit to operate from 2000 ft to 7000 ft (610 m to 2134 m) elevation with natural gas.

Note about this specification:

This specification is in the “Masterformat” as published by the Construction Specification Institute. Please feel free to copy this specification directly into your building spec.

Weather Expert® High Outdoor Air Cooling Only or Electric Heat Packaged Rooftop

HVAC Guide Specifications:

Size Range: 6 to 10 Nominal Tons

Carrier Model Number: 50LC*H

Part 1 — 23 06 80 Schedules for Decentralized HVAC Equipment

1.01 23 06 80.13 Decentralized Unitary HVAC Equipment Schedule

- A. 23 06 80.13.A. Rooftop unit schedule:
Schedule is per the project specification requirements.

Part 2 — 23 07 16 HVAC Equipment Insulation

2.01 23 07 16.13 Decentralized, Rooftop Units:

- A. 23 07 16.13.A. Indoor fan compartment:
1. Interior cabinet surfaces shall be insulated with a minimum 1/2 in. thick, minimum 1-1/2 lb density aluminum foil-faced insulation on the air side.
 2. Insulation and adhesive shall meet NFPA 90A requirements for flame spread and smoke generation.
 3. Unit internal insulation linings shall be resistant to mold growth in accordance with “mold growth and humidity” test in ASTM C1338, G21, and UL 181 or comparable test method. Air stream surfaces shall be evaluated in accordance with the “Erosion Test” in UL 181, as part of ASTM C1071.
- B. 23 07 16.13.B. Electric heat compartment:
1. Aluminum foil-faced fiberglass insulation shall be used.
 2. Insulation and adhesive shall meet NFPA 90A requirements for flame spread and smoke generation.

Part 3 — 23 09 13 Instrumentation and Control Devices for HVAC

3.01 23 09 13.23 Sensors and Transmitters:

- A. 23 09 13.23.A. Thermostats:
1. Thermostat *must*:
 - a. Have capability to energize 2 different stages of cooling and 2 different stages of heating.
 2. Thermostat *may*:
 - a. Energize both “Y” and “G” when calling for cooling.
 - b. Energize both “H” and “G” when calling for dehumidification.
 - c. Energize “G” when calling for venting.

B. 23 09 13.23.B. Sensors/Switches:

1. The unit shall include the following sensors/switches as factory-installed:
 - a. Return air temperature
 - b. Return air relative humidity
 - c. Outdoor air temperature
 - d. Outdoor relative humidity
 - e. Refrigerant circuit discharge pressure
 - f. Refrigerant circuit suction pressure
 - g. Refrigerant circuit high pressure switch
 - h. Condensate overflow switch
2. The unit shall include the following as factory provided, field installed:
 - a. Supply air temperature

Part 4 — 23 09 23 Direct Digital Control (DDC) System for HVAC

4.01 23 09 23.13 Decentralized, Rooftop Units:

- A. 23 09 23.13.A. Carrier SmartVu™ integrated Direct Digital Control (DDC) shall:
1. Include a factory-installed, color, touch-screen control interface that is factory wired and mounted in the unit control panel and is no less than 6.75 in. diagonally and has an environmental range of -4°F (-20°C) to 158°F (70°C), non-condensing.
 - a. The control interface must:
 - 1) Include an easy-to-understand menu with icon based navigation.
 - 2) Include a combination of graphical and text base screens for status.
 - 3) Include light colored backgrounds on screens. Black or dark gray backgrounds are not acceptable, due to poor visibility in daylight.
 2. Have no less than three levels of user access with password protection, including basic access without password, password protected user access, and password protected service access.
 3. Provide sensor/switch support for the factory installed sensors/switches listed in 23 09 13.23.B. Sensors/Switches, as well as the following field-installed sensors/switches:
 - a. Return CO₂
 - b. Return or supply air smoke detector
 - c. Supply duct static pressure
 - d. Building static pressure
 - e. Space temperature
 - f. Space relative humidity
 - g. Space CO₂
 - h. Mixed air temperature
 - i. Pre-filter status switch
 - j. Phase monitor

4. Provide support to the following field-provided control inputs:
 - a. 2-stage heat/cool thermostat (Y1, Y2, W1, W2, G)
 - b. Humidistat or thermostat dehumidification output (H)
 - c. Third-party outdoor air damper modulation (4-20mA)
 - d. Third-party indoor fan modulation (4-20mA)
 - e. Third-party exhaust fan modulation (4-20mA)
 - f. Remote shutdown/occupancy switch
 - g. Fire shutdown
5. Provide the following field use control outputs:
 - a. Alarm indicator
 - b. Damper override relay (heat, dehumidification, pre-occupancy operation)
6. Be capable of fully stand-alone, 2-stage heat/cool thermostat, Third-party DDC input control, or networked operation.
7. Provide control configurations for the following occupancy sources:
 - a. Local schedule
 - b. Occupancy switch
 - c. Network occupancy input
8. Provide network communication compatibility with the following protocols:
 - a. Carrier Comfort Network[®] (CCN)
 - b. BACnet MS/TP
 - c. BACnet IP
9. Establish demand for cooling or heating based on occupancy status, a demand source, and the source temperature. The control must:
 - a. Provide configurations for the following cooling/heating demand sources:
 - 1) Space temperature
 - 2) Outdoor air temperature
 - 3) Thermostat or third-party switch inputs
 - b. Limit control setpoints, settings, and configurations based on the demand source configuration.
 - c. Provide configurations to disable heating and cooling during the unoccupied period.
 - d. Provide user configurable temperature setpoints for the occupied and unoccupied periods, if allowed by the demand source.
 - e. Provide a user configurable supply air temperature setpoint for each demand.
10. Select a cooling or heating (if equipped) mode based on the supply air temperature setpoint established by the cooling or heating demand, the measured or calculated mixed air temperature, the unit configuration, the control settings, and cooling and heating system availability. The control must:
 - a. Operate the cooling or heating (if equipped) systems based on the supply air temperature setpoint established by the cooling/heating demand.
 - b. Provide a user configurable compressor lockouts based on outdoor air temperature and mixed air temperature.
 - c. Provide a user configurable heating (if equipped) lockout based on outdoor air temperature.
11. Establish a demand for dehumidification based on occupancy status, a demand source, and the source humidity. The control must:
 - a. Provide configurations to prevent dehumidification in the unoccupied period.
 - b. Provide configurations for the following dehumidification demand sources:
 - 1) Space relative humidity sensor
 - 2) Return air relative humidity
 - 3) Outdoor air dewpoint
 - 4) Humidistat, thermostat dehumidify switch, or third-party switch input
12. Select a dehumidification mode depending on the cooling coil temperature control from the dehumidification demand, the supply air temperature control point from the cooling or ventilation demand, the unit configuration, the control settings, and the dehumidification system availability. The control must:
 - a. Operate the cooling systems based on the cooling coil temperature control point established by the dehumidification demand and operate the hot gas reheat system based on the supply air temperature control point established by the cooling or ventilation demand.
13. Provide the following indoor fan speed control configurations, depending on the unit configuration and cooling/heating demand source:
 - 1) Constant speed
 - 2) Staged speeds based on demand (staged air volume, SAV[™])
 - 3) Variable speeds based on duct static pressure
 - 4) Variable speeds based on building static pressure
14. Provide operation of the unit exhaust fan (if equipped).
 - a. Provide the following exhaust fan speed control configurations, depending on the unit configuration:
 - 1) Two speeds based on outdoor air damper position
 - 2) Variable speeds based on building pressure

15. Provide operation of the outdoor air damper (if equipped).
 - a. Provide outdoor air damper fault detection and diagnostics (FDD) in accordance with California Title 24 and ASHRAE 90.1 requirements, if allowed by the demand source.
 - b. Provide configurations to disable free cooling with outdoor air based on the following:
 - 1) Outdoor air temperature
 - 2) Outdoor air enthalpy, outdoor air vs. return air enthalpy, or outdoor air vs. return air temperature
 - 3) Outdoor air dewpoint
 - c. Provide configurations to operate the outdoor air damper position based on:
 - 1) Two-position (closed and 100% OA)
 - 2) Indoor speed mapping
 - 3) A third-party control signal
16. Provide the following alarm capability:
 - a. Display current active alarm on the home screen.
 - b. Record the time and date of alarms.
 - c. Provide an alarm history of the latest 50 alarms.
17. Provide the following service capability:
 - a. Display the refrigerant suction and discharge pressure sensor readings on the control interface and over network points, without the need for field provided gauges.
 - b. Allow trending of unit temperature, pressures, and status/display trends on the control interface.
 - c. Include a component test mode to allow testing of individual components (if equipped), including the indoor fan, condenser fans, exhaust fan, and outdoor air damper.
 - d. Include a service run mode to allow testing of unit systems, including the cooling system, heating system, and reheat system.
 - e. Record run hours and starts for key components, such as compressors, the supply fan, and heating system.

Part 5 — 23 09 33 Integrated Staging Control (ISC) Board System for HVAC (Electro-Mechanical units)

- 5.01 23 09 33.13 Decentralized, Rooftop Units:
 - A. 23 09 33.13.A. General:
 1. Shall be complete with self-contained low-voltage control circuit protected by a resettable circuit breaker on the 24-v transformer side. Transformer shall have 75VA capability.
 2. Shall utilize color-coded wiring.
 3. Shall include a control and power wiring diagram affixed to the control panel door.

Part 6 — 23 09 93 Sequence of Operations for HVAC Controls

- 6.01 23 09 93.13 Decentralized, Rooftop Units:
 - A. 23 09 93.13.A. INSERT SEQUENCE OF OPERATION

Part 7 — 23 40 13 Panel Air Filters

- 7.01 23 40 13.13 Decentralized, Rooftop Units:
 - A. 23 40 13.13.A. Standard filter section
 1. Shall consist of factory-installed, low velocity, throwaway 2 in. thick fiberglass filters of commercially available sizes.
 2. Filters shall be accessible through an access panel with “no-tool” removal as described in the unit cabinet section of this specification (See Part 8 — 23 81 19.13.G).

Part 8 — 23 81 19 Self-Contained Air Conditioners

- 8.01 23 81 19.13 Small-Capacity Self-Contained Air Conditioners (50LC*H 07-12):
 - A. 23 81 19.13.A. General:
 1. Outdoor, rooftop mounted, ISC electrically controlled, heating and cooling unit utilizing hermetic scroll compressors for cooling duty and optional electric heat for heating duty.
 2. Factory assembled, single-piece heating and cooling rooftop unit. Contained within the unit enclosure shall be all factory wiring, piping, controls, and special features required prior to field start-up.
 3. Unit shall use Puron® (R-410A) refrigerant.
 4. Unit shall be installed in accordance with the manufacturer’s instructions.
 5. Unit must be selected and installed in compliance with local, state, and federal codes.
 - B. 23 81 19.13.B. Quality Assurance:
 1. Unit meets and exceeds ASHRAE 90.1-2013 minimum efficiency requirements.
 2. Unit shall be rated in accordance with AHRI Standards 340/360.
 3. Unit shall be designed to conform to ASHRAE 15, 2001.
 4. Unit shall be ETL/UL-tested and certified in accordance with ANSI Z21.47 Standards and UL-listed and certified under Canadian standards as a total package for safety requirements.
 5. Insulation and adhesive shall meet NFPA 90A requirements for flame spread and smoke generation.
 6. Unit internal insulation linings shall be resistant to mold growth in accordance with “mold growth and humidity” test in ASTM C1338, G21, and UL 181 or comparable test method. Air stream surfaces shall be evaluated in accordance with the “Erosion Test” in UL 181, as part of ASTM C1071.

7. Unit casing shall be capable of withstanding 500 hour salt spray exposure per ASTM B117 (scribed specimen).
 8. Roof curb shall be designed to conform to NRCA Standards.
 9. Unit shall be subjected to a completely automated run test on the assembly line. The data for each unit will be stored at the factory, and must be available upon request.
 10. Unit shall be designed in accordance with UL Standard 1995, including tested to withstand rain.
 11. Unit shall be constructed to prevent intrusion of snow and tested to prevent snow intrusion into the control box up to 40 mph.
 12. Unit shake tested to assurance level 1, ASTM D4169 to ensure shipping reliability.
 13. High-Efficiency Motors listed shall meet section 313 of the Energy Independence and Security Act of 2007 (EISA 2007).
- C. 23 81 19.13.C. Delivery, Storage, and Handling:
1. Unit shall be stored and handled per manufacturer's recommendations.
 2. Lifted by crane requires either shipping top panel or spreader bars.
 3. Unit shall only be stored or positioned in the upright position.
- D. 23 81 19.13.D. Project Conditions:
1. As specified in the contract.
- E. 23 81 19.13.E. Operating Characteristics:
1. Unit shall be capable of starting and running at 115°F (46°C) ambient outdoor temperature, meeting maximum load criteria of AHRI Standard 340/360 at ±10% voltage.
 2. Compressor with standard controls shall be capable of operation down to 40°F (4°C) ambient outdoor temperatures. Low ambient cooling operation may be additional limited by entering air conditions.
 3. Unit shall discharge supply air vertically or horizontally as shown on contract drawings.
 4. Unit shall be factory configured for vertical supply and return configurations.
 5. Unit shall be field convertible from vertical to horizontal airflow on all models. No special kit required on 07 models. Field-installed supply duct kit required for 08-12 size models only.
 6. Unit shall be capable of mixed operation vertical supply with horizontal return or horizontal supply with vertical return.
- F. 23 81 19.13.F. Electrical Requirements:
- Main power supply voltage, phase, and frequency must match those required by the manufacturer.
- G. 23 81 19.13.G. Unit Cabinet:
1. Unit cabinet shall be constructed of galvanized steel, and shall be bonderized and coated with a pre-painted baked enamel finish on all externally exposed surfaces.
 2. Unit cabinet exterior paint shall be:
Film thickness, (dry) 0.003 inches minimum, gloss (per ASTM D523, 60°F / 16°C): 60, Hardness: H-2H Pencil hardness.
 3. Evaporator fan compartment interior cabinet insulation shall conform to AHRI Standards 340/360 minimum exterior sweat criteria. Interior surfaces shall be insulated with a minimum 1/2 in. thick, 1 lb density, aluminum foil-faced fiberglass insulation. Aluminum foil-faced fiberglass insulation shall also be used in the heat compartment.
 4. Unit internal insulation linings shall be resistant to mold growth in accordance with "mold growth and humidity" test in ASTM C1338, G21, and UL 181 or comparable test method. Air stream surfaces shall be evaluated in accordance with the "Erosion Test" in UL 181, as part of ASTM C1071.
 5. Base Rail:
 - a. Unit shall have base rails on a minimum of 4 sides.
 - b. Holes shall be provided in the base rails for rigging shackles to facilitate maneuvering and overhead rigging.
 - c. Holes shall be provided in the base rail for moving the rooftop by fork truck.
 - d. Base rail shall be a minimum of 16 gauge thickness.
 6. Condensate pan and connections:
 - a. Shall be an internally sloped condensate drain pan made of a non-corrosive material.
 - b. Shall comply with ASHRAE Standard 62.
 - c. Shall use a 3/4 in. -14 NPT drain connection, possible either through the bottom or end of the drain pan. Connection shall be made per manufacturer's recommendations.
 7. Top panel:
Shall be a single piece top panel on 07 sizes, 2 piece on 08-12 sizes.
 8. Electrical Connections:
 - a. All unit power wiring shall enter unit cabinet at a single, factory-prepared, knockout location.
 - b. Thru-the-base capability:
 - 1) Standard unit shall have a thru-the-base electrical location(s) using a raised, embossed portion of the unit basepan.
 - 2) Optional, factory-approved, water-tight connection method must be used for thru-the-base electrical connections.

- 3) No basepan penetration, other than those authorized by the manufacturer, is permitted.
9. Component access panels (standard):
 - a. Cabinet panels shall be easily removable for servicing.
 - b. Unit shall have one factory-installed, toolless, removable, filter access panel.
 - c. Panels covering control box, indoor fan, indoor fan motor, gas components (where applicable), and compressors shall have molded composite handles.
 - d. Handles shall be UV modified, composite, permanently attached, and recessed into the panel.
 - e. Panels covering the control box, filter, fan motor, and compressor shall be hinged and include quarter turn latches.
 - f. Screws on the vertical portion of all removable access panel shall engage into heat resistant, molded composite collars.
 - g. Collars shall be removable and easily replaceable using manufacturer recommended parts.
- H. 23 81 19.13.H. Coils:
 1. Standard Aluminum Fin/Copper Tube Coils:
 - a. Standard evaporator, hot gas reheat, and condenser coils shall have aluminum lanced plate fins mechanically bonded to seamless internally grooved 5/16 in. diameter copper tubes with all joints brazed.
 - b. Evaporator and hot gas reheat coils shall be leak tested to 150 psig, pressure tested to 450 psig, and qualified to UL 1995 burst test at 1775 psig.
 - c. Condenser coils shall be leak tested to 150 psig, pressure tested to 650 psig, and qualified to UL 1995 burst test at 1980 psig.
- I. 23 81 19.13.I. Refrigerant Components:
 1. Refrigerant circuit shall include the following control, safety, and maintenance features:
 - a. Thermostatic Expansion Valve (TXV) shall help provide optimum performance across the entire operating range. Shall contain removable power element to allow change out of power element and bulb without removing the valve body.
 - b. Refrigerant filter drier - solid core design.
 - c. Service gauge connections on suction and discharge lines.
 - d. Single circuit design with tandem compressor and fully activated evaporator coil.
 - 1) Fully modulating low load protection valve that reduces the effective system capacity by redirecting discharge gas into the suction inlet. 2-position low load protection valves, such as hot gas bypass or suction shutoff valves are not acceptable. Low load protection valves that direct discharge gas into the evaporator are not acceptable.
2. Compressors:
 - a. Models shall use a minimum of two fully hermetic scroll compressors in a tandem compressor configuration. Single compressor models are not acceptable.
 - b. Models shall be available with a single refrigerant circuit and a minimum of 3 stages of cooling operation.
 - 1) The compressor shall be capable of operating for a minimum of 2-1/2 hours at its lowest stage of operation without the need to increase compressor capacity or speed for the purpose of oil returns.
 - 2) Models that include inverter or variable frequency drive compressors shall include an isolation transformer.
 - c. Compressor motors shall be cooled by refrigerant gas passing through motor windings.
 - 1) Models that include inverter or variable frequency drive compressors shall also include a refrigerant cooled inverter or VFD.
 - d. Compressors shall be internally protected from high discharge temperature conditions.
 - e. Compressors shall be protected from an over-temperature and over-ampereage conditions by an internal, motor overload device.
 - f. Compressor shall be factory mounted on rubber grommets.
 - g. Compressor motors shall have internal line break thermal, current overload and high pressure differential protection.
 - h. Crankcase heater shall be standard on each compressor and deactivated whenever a compressor is in operation.
- J. 23 81 19.13.J. Filter Section:
 1. Filter access is specified in the unit cabinet section of this specification.
 2. Filters shall be held in place by a pivoting filter tray, facilitating easy removal and installation.
 3. Shall consist of factory-installed, low velocity, throw-away 2 in. thick fiberglass filters.

4. Filters shall be standard, commercially available sizes.
5. Only one size filter per unit is allowed.
- K. 23 81 19.13.L. Indoor Fan and Motor with EcoBlue™ Technology:
 1. Direct Drive Evaporator Fan Motor:
 - a. Shall have permanently lubricated bearings.
 - b. Shall have inherent automatic-reset thermal overload protection.
 - c. Shall be an electronically commutated motor (ECM).
 - d. Shall have slow ramp up to speed capabilities.
 - e. Shall not include a belt or sheave system.
 - f. Shall be internally protected from electrical phase reversal and loss.
 - g. Motor speed setup and control setup shall be accomplished using the SmartVu™ control.
 - h. Medium static motor option shall include a minimum 2.4 HP motor and provide up to 2 in. wg external static capability at up to 350 cfm/ton.
 2. Indoor Fan:
 - a. Speed control shall be easily setup from the SmartVu™ control interface. Control configurations shall include:
 - 1) Staged Air Volume (SAV™)
 - 2) Constant volume
 - 3) Variable Air Volume (VAV) duct pressure control
 - 4) Variable Air Volume (VAV) space pressure control
 - 5) Third-party input control
 - b. Shall be a vane axial fan design with 75% less moving parts than a conventional belt drive system.
 - c. Shall be constructed of a cast aluminum stator and high impact composite material on rotor and air inlet casing.
 - d. Shall be patented/patent pending design with a corrosion resistant material and dynamically balanced.
 - e. Shall have slow ramp up to speed capabilities to help reduce sound and comfort issues typically associated with single speed belt drive systems.
 - f. Shall be a slide out design with simple screw removal.
 - g. Fans shall be capable of operating up to 350 cfm/tons.
 - h. Fans shall be capable of operating down to 130 cfm/tons.
- L. 23 81 19.13.L. Condenser Fans and Motors:
 1. Condenser fan motors:
 - a. Shall be a totally enclosed – multi-speed ECM motor.
 - b. Shall use permanently lubricated bearings.
 - c. Shall have inherent thermal overload protection with an automatic reset feature.
 - d. Shall use a shaft-down design on 07 models and shaft-up on 08-12 models with rain shield.
 2. Condenser Fans:
 - a. Shall be a direct-driven propeller type fan.
 - b. Shall have galvanized aluminum (galvalum) blades riveted to corrosion-resistant steel spiders and shall be dynamically balanced.
- M. 23 81 19.13.N. Special Features Options and Accessories:
 1. Electric Heat (factory-installed):
 - a. Heating Section:
 - 1) Unit shall include a factory-installed electric heater. Electric heater power shall be provided by the main unit power feed (single point power).
 - 2) Heater element open coil resistance wire, nickel-chrome alloy, strung through ceramic insulators mounted on metal frame. Coil ends are staked and welded to terminal screw slots.
 - 3) Heater assemblies are provided with integral fusing for protection of internal heater circuits not exceeding 48 amps each. Auto reset thermo limit controls, magnetic heater contactors (24-v coil) and terminal block all mounted in electric heater control box (minimum 18 ga galvanized steel) attached to end of heater assembly.
 - 4) Heater shall include a silicon rectifier control (SCR) for modulated heater output. Staged electric heaters or solid state relay (SSR) heaters are not acceptable.
 - 5) The heater shall include an alarm relay to indicate a high temperature limit switch trip on the SmartVu™ display.
 2. High Static Indoor Fan Motor (factory-installed):
 - a. Shall include a minimum 5 HP motor and provide up to 3 in. wg external static capability at up to 350 cfm/ton.
 3. Duct Pressure Control:
 - a. Shall include a factory-installed duct pressure transducer for supply fan speed modulation based on duct static pressure.
 - b. Pneumatic tubing and pressure pickup port are field supplied.

4. Zone Static Pressure Control:
 - a. Shall include a factory-installed building static pressure transducer for supply fan speed modulation based on zone static pressure.
 - b. Pneumatic tubing and pressure pickup port are field supplied.
5. Pre-coated aluminum-fin condenser coils:
 - a. Shall have a durable epoxy-phenolic coating to provide protection in mildly corrosive coastal environments.
 - b. Coating shall be applied to the aluminum fin stock prior to the fin stamping process to create an inert barrier between the aluminum fin and copper tube.
 - c. Epoxy-phenolic barrier shall minimize galvanic action between dissimilar metals.
 - d. Corrosion durability of fin stock shall be confirmed through testing to be no less than 1000 hours salt spray per ASTM B117-90.
 - e. Corrosion durability of fin stock shall be confirmed through testing to have no visible corrosion after 48 hour immersion in a room temperature solution of 5% salt, 1% acetic acid.
 - f. Fin stock coating shall pass 2000 hours of the following:
 - 1) One week exposure in the prohesion chamber followed by one week of accelerated ultraviolet light testing.
 - a) Prohesion chamber: the solution shall contain 3.5% sodium chloride and 0.35% ammonium sulfate. The exposure cycle is one hour of salt fog application at ambient followed by one hour drying at 95°F (35°C).
6. Optional e-coated aluminum-fin indoor air and/or condenser coils:
 - a. Shall be available as factory-installed on the indoor air coils (evaporator and hot gas reheat) and or condenser coils.
 - b. Shall have a flexible epoxy polymer coating uniformly applied to all coil surface areas without material bridging between fins.
 - c. Coating process shall ensure complete coil encapsulation of tubes, fins and headers.
 - d. Color shall be high gloss black with gloss per ASTM D523-89.
 - e. Uniform dry film thickness from 0.8 to 1.2 mil on all surface areas including fin edges.
 - f. Superior hardness characteristics of 2H per ASTM D3363-92A and cross-hatch adhesion of 4B-5B per ASTM D3359-93.
 - g. Impact resistance shall be up to 160 in.-lb (ASTM D2794-93).
 - h. Humidity and water immersion resistance shall be up to minimum 1000 and 250 hours respectively (ASTM D2247-92 and ASTM D870-92).
 - i. Corrosion durability shall be confirmed through testing to be no less than 6000 hours salt spray per ASTM B117-90.
7. Condenser Coil Hail Guard Assembly (factory or field installed):
 - a. Shall protect against damage from hail.
 - b. Shall be louvered design.
8. Ultra-Low Leak Economizers (factory or field-installed):
 - a. Available as a factory-installed option (vertical only) or field-installed accessory (vertical or horizontal) on most models.
 - b. Ultra-Low Leak economizer dampers meet California's Title 24 section 140.4 prescriptive requirements for leakage, reliability testing, etc., and ASHRAE 90.1-2013 requirements for damper leakage.
 - c. Economizers are available with EconoMi\$er®2 controls for SmartVu units.
 - d. Integrated, gear driven opposed blade design type capable of simultaneous economizer and compressor operation.
 - e. Damper blades shall be galvanized steel with composite gears. Plastic or composite blades on intake or return shall not be acceptable.
 - f. Shall be equipped with gear driven dampers for both the outdoor ventilation air and the return air for positive air stream control.
 - g. Shall be capable of introducing up to 100% outdoor air.
 - h. Economizer's barometric relief dampers shall be sized to allow up to 100% relief (actual results will be based on specific job conditions).
 - 1) EconoMi\$er®2 Economizer Controls:
 - a) For use with factory-installed (vertical only) or field-installed accessory (vertical or horizontal) on all SmartVu units.
 - b) EconoMi\$er2 economizers are controlled by SmartVu, which shall be 4 to 20mA design.
 - c) SmartVu controls meet California's Title 24 section 120.2 mandatory requirements for economizer Fault Detection and Diagnosis.
 - d) The control shall include all sensors to provide free cooling economizer operation based on dry bulb, enthalpy, differential dry bulb, or differential enthalpy changeover control and dewpoint cut-off.

- e) Shall be designed to spring return close outside air damper during loss of power.
 - f) Actuator shall be direct coupled to economizer gear. No linkage arms or control rods shall be acceptable.
 - g) The economizer shall maintain minimum airflow into the building during occupied period and provide design ventilation rate for full occupancy.
 - h) Controller shall drive outside air dampers completely closed when the unit is in the unoccupied period.
9. Unit-Mounted, Non-Fused Disconnect Switch (factory-installed):
- a. Switch shall be factory-installed, internally mounted.
 - b. National Electric Code (NEC) and ETL/UL approved non-fused switch shall provide unit power shutoff.
 - c. Shall be accessible from outside the unit.
 - d. Shall provide local shutdown and lockout capability.
 - e. Sized only for the unit as ordered from the factory. Does not accommodate field-installed devices.
10. HACR Breaker (factory-installed):
- a. These manual reset devices provide overload and short circuit protection for the unit. Factory wired and mounted with the units, with access cover to help provide environmental protection. On 575-v applications, HACR breaker can only be used with WYE power distribution systems. Use on Delta power distribution systems is prohibited.
 - b. Sized only for the unit as ordered from the factory. Does not accommodate field-installed devices.
11. Convenience Outlet (factory-installed):
- a. Powered convenience outlet:
 - 1) Outlet shall be powered from main line power to the rooftop unit.
 - 2) Outlet shall be powered from line side or load side of disconnect by installing contractor, as required by code. If outlet is powered from load side of disconnect, unit electrical ratings shall be ETL/UL certified and rated for additional outlet amperage.
 - 3) Outlet shall be factory-installed and internally mounted with easily accessible 115-v female receptacle.
 - 4) Outlet shall include 15 amp GFI receptacles with independent fuse protection.
 - 5) Voltage required to operate convenience outlet shall be provided by a factory-installed step-down transformer.
 - 6) Outlet shall be accessible from outside the unit.
 - 7) Outlet shall include a field-installed “Wet in Use” cover.
- b. Non-powered convenience outlet:
- 1) Outlet shall be powered from a separate 115/120-v power source.
 - 2) A transformer shall not be included.
 - 3) Outlet shall be factory-installed and internally mounted with easily accessible 115-v female receptacle.
 - 4) Outlet shall include 15 amp GFI receptacles with independent fuse protection.
 - 5) Outlet shall be accessible from outside the unit.
 - 6) Outlet shall include a field-installed “Wet in Use” cover.
12. Roof Curbs (field-installed):
- a. Full perimeter roof curb with exhaust capability providing separate air streams for energy recovery from the exhaust air without supply air contamination.
 - b. Formed galvanized steel with wood nailer strip and shall be capable of supporting entire unit weight.
 - c. Permits installation and securing of ductwork to curb prior to mounting unit on the curb.
13. Thru-the-Bottom Utility Connectors (factory or field-installed):
- a. Kit shall provide connectors to permit electrical and gas connections to be brought to the unit through the basepan.
14. Indoor Air Quality (CO₂) Sensor (factory or field-installed):
- a. Shall be able to provide demand ventilation indoor air quality (IAQ) control.
 - b. The IAQ sensor shall be available in duct mount, wall mount, or wall mount with LED display. The setpoint shall have adjustment capability.
15. Smoke Detectors (factory or field-installed):
- a. Shall be a 4-wire controller and detector.
 - b. Shall be environmental compensated with differential sensing for reliable, stable, and drift-free sensitivity.
 - c. Shall use magnet-activated test/reset sensor switches.
 - d. Shall have tool-less connection terminal access.
 - e. Shall have a recessed momentary switch for testing and resetting the detector.

- f. Controller shall include:
 - 1) One set of normally open alarm initiation contacts for connection to an initiating device circuit on a fire alarm control panel.
 - 2) Two Form-C auxiliary alarm relays for interface with rooftop unit or other equipment.
 - 3) One Form-C supervision (trouble) relay to control the operation of the Trouble LED on a remote test/reset station.
 - 4) Capable of direct connection to two individual detector modules.
 - 5) Can be wired to up to 14 other duct smoke detectors for multiple fan shutdown applications.
- 16. Horn/Strobe Annunciator (field-installed):
 - a. Provides an audible/visual signaling device for use with factory-installed option or field-installed accessory smoke detectors.
 - 1) Requires installation of a field-supplied 24-v transformer suitable for 4.2 VA (AC) or 3.0 VA (DC) per horn/strobe accessory.
 - 2) Requires field-supplied electrical box, North American 1-gang box, 2 in. (51 mm) x 4 in. (102 mm).
 - 3) Shall have a clear colored lens.
- 17. Double Wall Construction (factory-installed):
 - a. The indoor air touching sections of the unit interior, including top, sides, and base pan, shall be covered with a galvanized steel liner over the R4 foil faced fiberglass insulation
- 18. Supply Duct Kit (field-installed):
 - a. On 08-12 models, a supply air duct cover kit is required when field converting the factory standard vertical duct supply to horizontal duct supply configuration. One required per unit.
- 19. 4 in. Filter Rack (factory or field-installed):
 - a. Shall include a field or factory-installed filter rack that accepts nominal 4 in. filters.
 - b. Shall include factory or field-installed nominal 4 in. MERV 8 filters.
 - c. Shall include factory or field installed nominal 4 in. MERV 13 filters.

