

THE PROFESSIONAL MAGAZINE FOR ELECTRONICS AND COMPUTER SERVICING

ELECTRONICTM

Servicing & Technology

December 1995

SCR "chopper" regulators and shutdown circuits

Replacement parts/servicing information sourcebook

Test equipment showcase



U.S. \$3.00



1 2>

PULL-OUT PROFAX
JC Penney Color TV
Model No. 1048/1049

NEW Products for Electronic Service and Repair

BrushClean™ System

Now there is a fast, safe, effective way to give contaminants the brush-off. The new BrushClean™ System combines powerful solvents with the gentle scrubbing action of a brush. Use three ways: spot clean economically with the brush, flush under SMDs with the extension tube, or clean large areas with the spray nozzle. Three powerful tools – one convenient package.



Now available:

CFC Free Flux-Off® 2000
Cleaning system quickly and completely removes R, RMA, RA and synthetic flux.

Flux-Off® II
Proprietary alcohol blend cleaning system removes water soluble and all other fluxes quickly.

CFC Free Electro-Wash® 2000
Fast drying one step cleaning and degreasing system safe for most plastics.

Pow-R-Wash™
Highly effective nonflammable precision cleaning system safe for use on metals and most plastics.



The BrushClean System features the new All-Way Spray Valve that sprays in any direction, even upside down!



FoamClean™ Label Adhesive Remover

At last—an easy way to remove the grime collecting adhesive residue left behind by tape, stickers and labels. It's as simple as peel, spray and wipe. This hard working foam is engineered to be safe for use on plastics, and it even clings to vertical surfaces! And that means no runs, no drips and no puddles to clean up. Count on Label Adhesive Remover to get you out of sticky situations.



Using FoamClean Label Adhesive Remover.

Label Adhesive Remover is engineered to restore office equipment to like new condition:

- Step One**
▶ Peel away label.
- Step Two**
▶ Spray foam onto sticky residue.
- Step Three**
▶ Wait for foam to collapse and wipe clean.

It's that simple! Thoroughly removes sticky residue left by:

- labels • stickers • tape • gum • lipstick • crayon

 **Chemtronics®**
The Solutions Source. Worldwide.™

YES! Please send my **FREE** copy of ChemFacts—a comprehensive guide for selecting the right cleaning products for electrical and electronics service, rework and repair.

Also send information on BrushClean™ System FoamClean™ Label Adhesive Remover

Name _____ Title _____

Company _____

Phone _____ Fax _____

Street Address _____

City _____ State _____ Zip _____

Which describes your business:

Production Service and Repair Other

Number of technicians using the type of cleaning product in this ad _____

Which best describes your role:

Recommend/specify products Purchase Other

? CALL 1-800-645-5244

FAX THIS PAGE 770-423-0748

Mail to:

Chemtronics, Inc. • 8125 Cobb Center Dr. • Kennesaw, GA 30152
Circle (115) on Reply Card

Contents

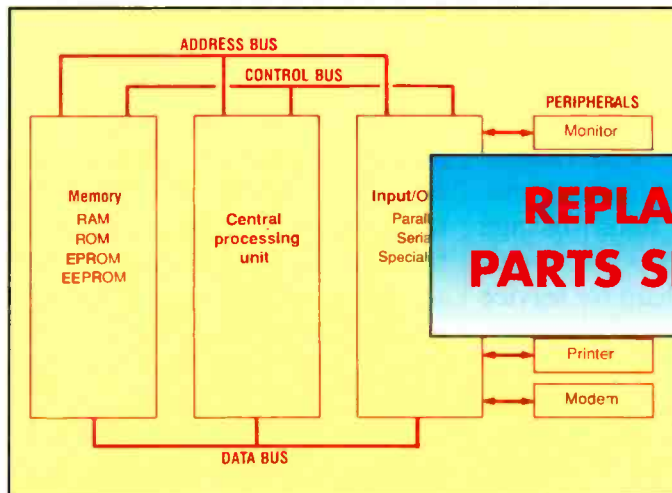

Page 58

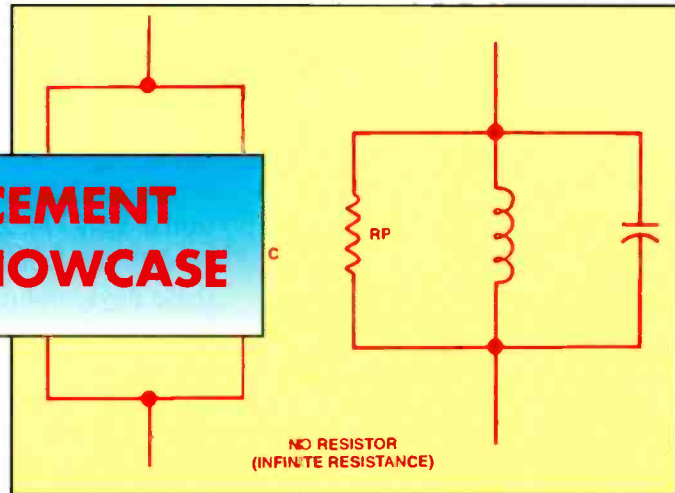

Page 64

FEATURES

6 Replacement parts/ servicing sourcebook

By The ES&T Staff

Each year in the December issue, ES&T publishes this replacement parts and servicing information sourcebook to help our readers locate replacement parts and service information.

19 SCR "chopper" regulators and shutdown circuits

By Steve Babbert

This article discusses the basics of SCRs, and how and why they are used in television receivers.

25 Troubleshooting a Citizen JCTV3049X Television

By Ron C. Johnson

Troubleshooting is not easy, and it is occasionally not profitable. This article helps you to troubleshoot a Citizen TV while still being able to make some money.

DEPARTMENTS

2 Editorial

4 News

16 Troubleshooting tips

33 Profax

58 Computer Corner

Computer basics

61 Books

62 What Do You Know About Electronics?

An old question about resonance, with a new slant

65 ES&T Calendar of Events

65 Test Your Electronics Knowledge

66 Photofacts

68 Literature

69 Classified/ Readers' Exchange

72 Advertisers' Index

SPECIAL ADVERTISING SUPPLEMENT

43 Test Equipment Showcase

Today's consumer electronics test equipment products are highly complex. Because of this, the decision to purchase one is so vital, the more you know about the manufacturers of suppliers, the better informed your decision will be. This special advertising section is a way to help bring more information about test equipment providers to our readers. Every advertiser in this section has been given space to tell readers something about their company, or to help readers understand the value and use of that company's products. ES&T invites you to read what these companies have to say.

ON THE COVER

As consumer electronics technology advances, new pieces of test equipment are introduced, and new features are added to existing test products. All of this makes it increasingly difficult for the service technician to select the right test device. In this Test Equipment Showcase, advertisers are given additional space to describe their products and services, thus helping technicians with those difficult choices. (Photo courtesy Wavetek)

THE PROFESSIONAL MAGAZINE FOR ELECTRONICS AND COMPUTER SERVICING

ELECTRONIC

Servicing & Technology

Information you could use

It's time once again for us to present our Replacement Parts/Service Information annual issue. We publish this issue once a year, and have done so for the past decade or so. The reason we publish this annual informational issue is that things change rapidly in consumer electronics these days, and it's hard for service centers to keep up with the changes. In fact, the type of question we're most often asked by our readers is not related to any of the technical aspects of servicing.

About half of all letters and telephone calls we get from our readers are questions like; "Do you have an address or telephone number for XYZ Corporation?", or "I tried to obtain service literature from ABC Company and they refused to provide it to me. Where can I go to get this type of information?"

The information provided in this issue won't answer all such questions, but it provides two broad categories of information that will help point any service center in the right direction when they're trying to find that elusive service manual or replacement part needed to service that TV or VCR on which they're stumped.

For starters, this issue contains listings of manufacturers and distributors with their addresses, and phone and fax numbers that readers may not have access to. In some cases, a call to one of these organizations may be all it takes to find the required bit of information or component needed to complete service on that TV set that's been sitting on the shelf and get it back into the hands of the owner, thus improving your service center's customer satisfaction quotient and adding a little bit to the bottom line.

We also include a listing of organizations: national, state and local. For those of you who don't belong to a servicer's association, you might at

least try talking to one in your area. Most technicians who belong to such a group find that by talking to fellow members, by attending meetings and seminars sponsored by these groups, they are able to gain information that helps them in all aspects of their business, including where to find service information and replacements. Also listed in this issue are sources that can provide invaluable information. We think that every service center should have at least some of them. For example, the Consumer Electronics Show (CES) Guide, available from the Electronics Industries Association (EIA) at a reduced price by sending in the coupon in this issue, contains a listing of all of the exhibitors at CES. This listing contains addresses, telephone numbers and a listing of the key people to contact at most of the major consumer electronics manufacturers.

The Consumer Electronics Replacement Parts Source Book also available from the EIA contains a list of manufacturers along with the names, addresses and telephone numbers of either the service division of the company, or distributors who handle the company's products.

We are in what many call the "information age." Those who have the requisite information prosper. Those who don't, don't. Having some of these information resources can help speed up the process when it comes to contacting the source of information or parts you need. The cost of maintaining an up to date library of such information sources is small compared to what it would cost in time and long distance calls that you may encounter if you don't have them. ■

Mike Conrad Penner

ELECTRONIC

Servicing & Technology

Electronic Servicing & Technology is edited for servicing professionals who service consumer electronics equipment. This includes service technicians, field service personnel and avid servicing enthusiasts who repair and maintain audio, video, computer and other consumer electronics equipment.

EDITORIAL

Nils Conrad Persson, *Editor*
Kirstie A. Wickham, *Associate Editor*
Richard S. Moseson, *NW2L, On-Line Coordinator*

CONSULTING EDITORS

Homer L. Davidson, *TV Servicing Consultant*
Victor Meeldijk, *Components Consultant*
John E. Shepler, *Audio Consultant*
Sam Wilson, *Electronics Theory Consultant*

PRODUCTION

Elizabeth Ryan, *Art Director*
Barbara Terzo, *Associate Art Director*
Susan Oliveri, *Assistant Art Director*
Edmond Pesonen, *Electronic Composition Mgr.*
Dorothy Kehrwieler, *Production Manager*
Emily Kreutz, *Assistant Production Manager*
Pat Le Blanc, *Phototypographer*

BUSINESS

Richard A. Ross, *Publisher*
John Dorr, *General Manager*
Frank V. Fuzia, *Controller*
Simon Schatzmann, *Circulation Director*
Catherine Ross, *Circulation Manager*
Melissa Nitschke, *Operations Manager*
Carol Licata, *Data Processing*
Denise Pyne, *Customer Service*

SALES OFFICE

Electronic Servicing & Technology
76 N. Broadway, Hicksville, NY 11801
516-681-2922; FAX 516-681-2926
Diane G. Klusner, *Director of Advertising*
Emily Kreutz, *Sales Assistant*

EDITORIAL CORRESPONDENCE:

P.O. Box 12487
Overland Park, KS 66212
913-492-4857



Electronic Servicing & Technology (ISSN 0278-9922) is published 13 times a year by CQ Communications, Inc. 76 N. Broadway, Hicksville, NY 11801. Telephone (516) 681-2922. Second class postage paid at Hicksville, NY and additional offices. Subscription prices (payable in US dollars only): Domestic—one year \$24.75, two years \$45. Foreign countries—one year \$30.75, two years \$57. Entire contents copyright 1995 by CQ Communications, Inc. Electronic Servicing & Technology or CQ Communications, Inc. assumes no responsibility for unsolicited manuscripts. Allow six weeks for delivery of first issue and for change of address. Printed in the United States of America.

Postmaster: Please send change of address notice to Electronic Servicing & Technology, 76 N. Broadway, Hicksville, NY 11801.

CQ Communications, Inc. is publisher of CQ The Radio Amateur's Journal, Popular Communications, Micro-Computer Journal, CQ Radio Amateur (Spanish CQ), CQ Amateur Radio Equipment Buyer's Guide, CQ Amateur Radio Beginner's Buyer's Guide, Popular Communications Guide, and Electronic Servicing & Technology.



Raise your standard to Wavetek.

Why choose between paying more for a brand name or getting more functions for your money? Get the best of both worlds with **Wavetek**.

Worldwide Service. Support whenever and wherever you need it.

Tech-preferred Features. The XL meters have the largest displays, auto-off, data hold, manual and autoranging models in pocket-size convenience.

Quality. Less than 0.5% warranty returns assures continuous reliability.

Selection. Over 35 different **Wavetek** DMMs to meet any measurement need.

User Safety. Conservative voltage ratings, fused inputs, warning beepers, shrouded test leads, and designs that meet worldwide agency approvals.

Total Value. Eight XL Series meters from \$29.95 to \$99.95 to meet any requirement.

You don't need to pay more.
You can't afford to settle for less...

For the name and location of the **Wavetek** dealer near you, call

1-800-854-2708

(outside the U.S., call 619-279-2200)

Wavetek Corporation

9045 Balboa Avenue,
San Diego, CA 92123

©Wavetek Corp. 1995. Wavetek and the Wavetek logo are registered trademarks of the Wavetek Corporation

Circle (71) on Reply Card

WAVETEK

CET training via satellite scheduled for prime time

Nebraska's public broadcasting service, in conjunction with Mid-Plains Community College and the Electronics Technicians Association, Int'l., provides electronics technicians all over North America with satellite training aimed at passage of the Associate Certified Electronics Technician (CET) examinations.

The course, eligible for two semester-hour college credits, will begin Wednesday, January 10, and extend for twelve weekly three hour sessions.

Dick Glass, President of ETA and SDA, and administrator of the ETA Certification program said, "We are enthused about the prime-time positioning of the CET Training on Wednesday evenings. Electronics school students and employed technicians will find that time slot - 7:30 - 10:30 PM, most convenient. We found our previous satellite training efforts, produced by Central Community College (Grand Island), with a time slot of 1 PM on Fridays, were difficult for a majority of those wanting to take part to do so."

NEB*SAT has two satellite channels; S3-02 and S3-04. S3-04 is the channel which technicians can tune to for participation in the 12 week Associate CET course. Producers and instructors for the unscrambled course are: Gordon Koch, CET, and Dick Stephens, both electronics instructors at Mid Plains Community College in North Platte, NE.

There is a \$60 fee for those wanting to register for the course and to acquire the two semester hours credit. Mr. Koch explains, "We are looking for groups of several students or working technicians gathering each Wednesday at a school having downlink facilities on C-Band. The electronics instructor at that school can be the coordinator. The Associate CET exam can be taken at the site on the final evening of the course, April 15th. If a local area school is not a possibility, some Satellite Dealer Association (SDA) members will volunteer their display rooms for the course. Individual satellite owners who are electronics technicians may also provide the 'classroom' for this popular training program.

The course will concentrate on two chapters from the CET Exam Book (by Glass & Crow) (TAB4199) each evening,

with the latest Associate CET exam changes and updates being included in course materials. The March 20 Wednesday session will not be a course night as another network program will preempt the CET course.

Downlink study groups are already set up at McCook and North Platte, Nebraska. One military site in Texas and a local association group in Toronto, Canada have expressed interest in joining in the course as downlink locations.

Schools, study groups and individual techs who wish to register for the 2 semester-hour credit course should contact ETA (317-653-8262) or SDA (317-653-4301) or Mr. Koch directly: Mid Plains Community College, Gordon Koch, Electronics Dept., 1101 Halligan Drive, North Platte, NE 69101, 308-532-8740 x243, E-Maigpkoch@Ziggy.mpcc.cc.ne.us, fax: 308-532-8494.

The Certified Electronics Technician program was initiated in 1966 as an outgrowth of the US labor Department Bureau of Apprenticeship and Training Program, jointly administered by BAT and NEA - National Electronics Associations. Since then, some 50,000 electronics technicians have been certified. The program has extended to certification in ten different categories of electronics technician work: Consumer Electronics, Industrial, Radar, Wireless Communications, Satellite Equipment, Computer Electronics, Biomedical Equipment, Telecommunications, RF Video Distribution, and Avionics.

All CET aspirants must take the Associate (basic electronics) CET examination as one of two parts of a Journeyman CET exam. The Current S3-04 training course will concentrate on the Associate test during the January-April distance learning course originating from Mid Plains Community College in North Platte.

Fiber Optic Professional Association founded initially to focus on training and certification for fiber optics

The Fiber Optic Association, Inc. has been established as a professional association for persons working in all areas of fiber optic technology. The initial task of the FOA will be to develop training and certification programs for fiber optics.

Within the fiber optic industry, there are

organizations of companies that have been instrumental in developing standards for fiber optic components and testing, but never an organization for the individuals working in the industry, along the lines of the IEEE for electronics or SCTE for CATV. The FOA will fill this need.

The initial focus of the FOA will be on the topics most important to its members today: education and certification. The principals behind the organization, mainly instructors currently teaching fiber optics, have been working on the first handbook for fiber optic installation, due to be published by Delmar Publishing this fall. A teachers' guide will facilitate the use of the handbook in training classes. In addition, Fotec, Inc., the fiber optic test equipment company that runs the very successful "Fiber U" fiber optic training conferences, has authorized the FOA use the Fiber U "Final Exam" and trademark and expand it into a full certification program for the fiber optic industry.

The FOA fiber optic certification program comes at a critical time in the fiber optic industry. Fiber optics has reached a time of rapid growth, with the acceptance of fiber optics in CATV and LANs fueling the current growth. A shortage of qualified personnel to install and maintain fiber optic networks is leading to a number of new programs to train personnel in the technology. Certification of these persons, even licensing in some states, has become a major concern.

The FOA educational program is already being incorporated into many fiber optic training programs in educational institutions, and professional training organizations. Future plans include development of simplified programs appropriate at all levels, even to the level of high school science courses.

The FOA was officially incorporated in Massachusetts July 12, 1995 as a non-profit trade organization. The principals behind the FOA are Jim Hayes, Director of Fiber U and President of Fotec, Inc., Professor Elias Award of Wentworth Institute of Technology, Eric Pearson of Pearson Technologies, Paul Rosenberg of EC Magazine and NECA, and John Highhouse of Lincoln Trail College. All five of these individuals have been pioneers in fiber optic training and are actively involved in fiber optic training. ■



EIA Hands-On Technical Training Workshops

For Electronics Instructors and Technicians

The Electronic Industries Association (EIA) will offer the following courses in Basic Color Television Servicing, VCR Technology, Video Laser Disc Servicing, and Computer Monitor Servicing covering theory and hands-on-training. Laser Disc, and TV Monitor workshops are three days; VCR workshops are five days; all classes have an enrollment of 20 people. Please refer to the concise workshop outline below for selected course topics. Designed to upgrade the skills of both servicing technicians and instructors of vocational education, these workshops are organized by the Product Services Committee of EIA's Consumer Electronics Group. **The workshops are provided by EIA for a minimal fee of \$50⁰⁰.** Anyone interested in attending should contact Product Services (703)907-7656 for space availability and details. EIA is also offering CEUs this year. For general questions pertaining to EIA's educational programs, please contact our staff:

**Product Services, EIA/CEG, 2500 Wilson Boulevard,
Arlington, VA 22201-3834 or call (703)907-7670**

Web Site: <http://www.eia.org>

For over seventy years EIA has been the primary trade association representing major U.S. manufacturers of audio, video, mobile electronics, accessories, home office and home automation products, and assistive devices for people with disabilities. In addition to managing the International Consumer Electronics Shows, EIA's Consumer Electronics Group member manufacturers work to promote optimum servicing of consumer electronic products and foster interest in continuing education of electronics technicians through the Product Services Department.



Color TV Technology & Servicing

- ◆ NTSC Signal Processing
- ◆ Test Equipment
- ◆ Receiver Alignments
- ◆ Troubleshooting Techniques

3 days 2.0 CEUs

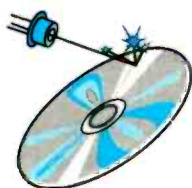

Video Laser Disc Technology & Servicing

- ◆ VLD Servo Systems
- ◆ Video Signal Path
- ◆ Laser Optics
- ◆ Troubleshooting Techniques

3 days 2.0 CEUs



VCR Technology & Servicing

- ◆ VCR Servo Systems
- ◆ VHS Signal Processing
- ◆ Tape Transport Alignment
- ◆ Troubleshooting Techniques

5 days 3.5 CEUs

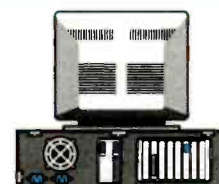

Computer Monitor Servicing

- ◆ Signal Formats
- ◆ Test Equipment
- ◆ Monitor Alignments
- ◆ Troubleshooting Techniques

3 days 2.0 CEUs

1995-96 Technical Workshop Schedule

Workshop	Location	City/State	Date	Workshop	Location	City/State	Date
CTV	EIA - Headquarters	Arlington, VA	Nov. 6-8, 95	CTV	Tampa Technical Institute	Tampa, FL	Jan. 3-5, 96
VLD	EIA - Headquarters	Arlington, VA	Jan. 24-26, 96	CTV	Tampa Technical Institute	Tampa, FL	Apr. 3-5, 96
MON	EIA - Headquarters	Arlington, VA	Feb. 20-22, 96	CTV	Tampa Technical Institute	Tampa, FL	Jul. 1-3, 96
CTV	EIA - Headquarters	Arlington, VA	Mar. 27-29, 96	CTV	Tampa Technical Institute	Tampa, FL	Oct. 2-4, 96
VCR	EIA - Headquarters	Arlington, VA	Apr. 15-19, 96	CTV	Mt. San Antonio Comm. Coll.	Walnut, CA	Nov. 13-15, 95
MON	EIA - Headquarters	Arlington, VA	Jun. 5-7, 96	CTV	Mt. San Antonio Comm. Coll.	Walnut, CA	Mar. 11-13, 96
CTV	Triton Com. College	River Grove, IL	Mar. 11-13, 96	CTV	Mt. San Antonio Comm. Coll.	Walnut, CA	Jun. 3-5, 96
CTV	Triton Com. College	River Grove, IL	Jul. 15-17, 96	CTV	Mt. San Antonio Comm. Coll.	Walnut, CA	Nov. 11-13, 96
CTV	Triton Com. College	River Grove, IL	Oct. 14-16, 96				

CTV = Color TV Servicing & Technology

VLD = Video Laser Disc Servicing & Technology

Puma\O95

MON = Computer Monitor Servicing

VCR = Video Cassette Recorder Servicing & Technology

These courses fulfill the "training" requirements for preliminary service authorization for most major manufacturers

Replacement parts/servicing information sourcebook

By The ES&T Staff

Consumer electronics products are not made to last forever. The standard useful life of a TV, VCR, stereo, or other consumer electronic product is considered to be between seven and ten years. A well-made consumer electronics product may actually last well beyond that, but service literature and replacement parts for it will be available on a hit or miss basis.

Moreover, this useful product life applies to products manufactured by the reputable manufacturers that have recognizable names. The useful life of some of the fly-by-night manufacturers, whose products show up with unrecognizable names on the shelves of the discount stores may be considerably less, or nonexistent.

The stability of a consumer electronics product manufacturer is generally only as good as the reputation of the company. If a consumer buys an RCA or GE TV set, or a Magnavox or Panasonic VCR, they can reasonably expect that that company will be around in seven years if the service center needs to obtain some replacement component.

If the consumer buys some obscure brand of a product, a Bohsei or Kawasho TV set for example, he should be aware that the great price he paid for the product may not seem so great when the company goes out of business, or retreats from the U.S. market, leaving a limited selection of replacement parts and service information behind in the hands of a distributor that may be hard to find.

Brands may not be what they seem.

These days, even large, reputable manufacturers import products from offshore and sell them under their own brand. *Generally* this is not a bad thing, as *generally* the reputable manufacturer maintains the quality of the product, and maintains stocks of replacement parts and service literature for the product during its useful life.

However, many brand names today have become commodities, and it has happened that a manufacturer with a venerable old name sells the brand to a company that then sells shoddy merchandise to unsuspecting consumers, who may then find it difficult, or not worth the bother and cost to get the product serviced.

Other factors that make service difficult

These are only a few of the factors that make it difficult for the average service center to locate and obtain service literature and replacement parts for some products. Some of the other reasons are:

- Companies move, and after a set amount of time the post office doesn't forward mail.
- Some companies are small and have a very low profile in the marketplace, so they're just hard to locate.
- Many private brands of consumer electronics products have little support.
- An offshore manufacturer may sell and support products in the U.S. for a period of time and then leave the market. In some cases these companies will have

sold their stocks of replacement parts to a distributor in the U.S., but how do you know who that is?

- Some companies don't wish to have independent service companies service their products, so they refuse to provide service literature and replacement parts to the independent.

Here's some help

Because consumer electronics servicing presents so many difficulties in locating replacement parts and service information, each year in December, we publish a replacement parts and servicing information sourcebook that provides service companies with several tools to help them overcome these problems.

This sourcebook is published annually because so many changes take place within a twelve month period that the list is largely out of date in a year.

This sourcebook contains the following sections:

- A list of suggested references.
- A list of FCC (Federal Communications Commission) ID number prefixes that identifies the manufacturer of any product that bears an FCC ID number.
- A sidebar that describes how to use the FCC public access system to look up the manufacturer of a product on which you have found an FCC ID number.
- A list of UL (Underwriters' Laboratories) ID numbers.
- An updated list of manufacturers with addresses and telephone numbers.

Finding replacement parts

Here's a list of references that are useful in tracking down the manufacturer, or parts distributors. We think that every electronics servicing facility should have them:

Consumer Electronics Replacement Parts Source Book

Consumer Electronics Group,
Electronic Industries Association
Product Services Department
2500 Wilson Blvd.
Arlington, VA 22201

Please send me a copy of the Consumer Electronics Show Directory, as mentioned in ES&T. Enclosed is a check for \$15.00, payable to the Consumer Electronics Show. (For ES&T readers only. Regular value is \$100.00.)

Name _____ Occupation/Title _____
Address _____
City _____ State _____ Zip _____

Mail to: CES, Attn: Michael Williams
2500 Wilson Blvd.
Arlington, VA 22201

FCC ID numbers

Code Prefix	Manufacturer
A3D	NEC
A3L	Samsung
A7R	Orion
AAL	Phone Mate
AAO	Radio Shack
AAY	Midland International Corporation
ABL	Hitachi
ABW	JC Penney
ABY	Motorola
ACA	Yorx Electronics
ACB	Phonotronics
ACJ	Matsushita
ADF	Carterfone
ADT	Funai
AES	Uniden
AEZ	Sanyo
AFA	Fisher
AFL	Sharp
AFR	Curtis Mathes
AGI	Toshiba
AGV	Montgomery Ward
AHA	RCA
AIH	Litton Microwave Cooking Products
AIX	Sylvania
AJU	GE
AK8	Sony
AKC	Superscope Inc
AKE	Marantz Co Inc
ALA	Wells Gardner Electronics Corporation
ALI	Kenwood USA Corporation
ANV	Capetronic Int'l Corporation
API	Harman Kardon Inc
ARR	AOC Int'l of America Inc
ASH	Akai
ASI	Victor Company of Japan
ATA	Sharp
ATO	Zenith Electronics Corporation
ATP	Advent Corporation
BEJ	Goldstar
BGB	Mitsubishi
BOU	Philips
EOZ	Shintom

*ASJ - FUJITSU
CBF - DAWGO
G95-*

This is a FCC and UL guide to original VCR manufacturer I found in the Taiko replacement video head guide July 6, 1994.

Original Manufacturer	UL listed code	FCC listed code
Akai	186Z	ASH
Fisher/Sanyo	403Y	AFA
Funai	333Z, 51K8	ADT, EOZ, BFY
Goldstar	86BO	BEJ
Hitachi	238Z	ABL, AHA
JVC	39F	ASI
Matsushita	679F	ACJ, AIX, AJU
Mitsubishi	536Y	BGB
NEC	781Y	A3D, E74
Orion-Emerson	44L6, 722	A7R
Philips	645Y	BOU
Samsung	16M4, 414K	A3L
Sharp	570F	AK8
Toshiba	174Y, 84X7	AGI, G95

← **Figure 1.** Every VCR, personal computer, cordless telephone and microwave oven must carry an FCC ID number. The first three characters of that ID identify the manufacturer of the product. This is a listing of manufacturer vs FCC ID number prefix, alphanumerically by code.

Electronic Industry Telephone Directory (Or some equivalent)

Harris Publishing Company
2057-2 Aurora Rd.
Twinsburg, OH 44087-1999

This will cost around \$50.00 (Or you might be able to get a copy free from your distributor).

The Howard W. Sams and Company Annual Photofact Index

Available from your distributor, or directly from (This document is available in printed form and on floppy disk)

Howard W. Sams & Company
2647 Waterfront Parkway East Drive
Indianapolis, IN 46214-2041
800-428-7267

Consumer Electronics Show (CES) Directory

Electronic Industries Association
Consumer Electronics Manufacturers Association
2500 Wilson Blvd.
Arlington, VA 22201
703-907-7600

The CES directory includes over 1,500 manufacturers, brand names, products and key personnel. The best way to get a copy of this directory is to attend the Consumer Electronics Show in Las Vegas, January 5 through January 8, 1996. It comes with the price of attendance. For further information about CES, write to the address above, or call the listed number and ask for CES Registration.

If you can't get to the show, limited numbers of copies of the directory will be available from the above address. Limited quantities of the CES Show directory will be available at a reduced price to **ES&T** readers who send in the coupon in this issue. Quantities of the directory are limited, but the EIA/CEMA will fill as many orders as possible.

A VCR model number and parts reference

Another invaluable reference is published by the International Society of Cer-

The FCC public-access information system

Every VCR, personal computer, microwave oven and cordless phone sold in the United States must bear an FCC identification number because they may possibly generate radio-frequency interference. Some products outside of this category, such as TV sets may also bear FCC ID numbers. This number identifies which company manufactured the unit. If you have one of these products in your shop for service and can't identify the manufacturer, you can contact the FCC through its public-access system and find out.

There are two ways to get this information: via voice telephone or via computer and modem by contacting the public-access bulletin board. The FCC prefers to have people use direct computer-to-computer contact.

To contact the FCC bulletin board, you must have a computer and a modem capable of 300 baud or 1200 baud. The number to call, in Maryland (just outside of Washington, D.C.), is 301-725-1072. This is a toll call. Dialing this number at any time should get you in direct contact with the bulletin board.

Once you have made contact, the computer screen will tell you how much time you have and provide you with a menu of items to choose from. When **ES&T** dialed up the bulletin board in October, and once we accessed the bulletin board the following screen information appeared:

"P A L"

- 1 - Access Equipment Authorization Database
- 2 - Definitions - Terms/Codes used in Application Records
- 3 - Applying for an Equipment Authorization (1/92)
- 4 - Other Commission Activities and Procedures (8/92)
- 5 - Laboratory Operational Information
- 6 - Public Notices (8/92)
- 7 - Bulletins / Measurement Procedures (5/92)
- 8 - Rulemakings (8/92)
- 9 - Help
 - a - Information Hotline (7/92)
 - b - ADVISORY COMMITTEE ON ADVANCED TELEVISION SERVICE
 - c - Processing Speed of Service (10/92)
 - d - Test Sites on File per Sec 2.948 (10/92)
- 0 - Exit PAL

Enter your selection:
Pressing the number 1 on the keyboard brought up the following information on the screen:

Equipment Authorization Database

Form 731: Until Form 731 is revised the March 1988 and

July 1989 editions may continue to be used. The OMB expiration dates shown on the forms do not affect public use. Availability of the revised Form 731 will be announced here and by public notice. est: 7/92

- 1 - Equipment Authorization Application Status
- 2 - Applicant/grantee Names and Addresses by Code
- 0 - Exit this Menu

Enter your selection:

Enter Grantee Code (CR to end): ...

At this point, it was only necessary to enter the three character alpha or alphanumeric code, and the name, address and telephone number of the manufacturer identified by that code appeared. For example, entering the three letter ID aaa and pressing the ENTER key brought up this information on the screen:

AAA Code A Phone Corporation
PO Box 5656
Portland, OR
97228 USA

The system gives you eight minutes at a time, and you can enter as many codes and gather as much information as you can in that time period. If your software allows you to download information, you can download all of this information to your computer's disk for future reference.

The other method of obtaining this information is to call 301-725-1585, Monday through Thursday between 2:00 and 4:30 p.m. and ask to be connected to the status desk. The individual who answers will relay your question to the bulletin board via a computer terminal and will then relay the information it provides to you.

Obviously, if you have a computer and a modem, it makes far more sense to contact the computer directly. You'll cut out the middle man and, of course, you can contact the computer any time.

Information sources close to home

Those of you who are located in a city that has a good library system have a ready source of information available free. For example, the **ES&T** staff regularly calls the local library for information. References that they have available include the Thomas Catalog, a book called "Companies and their brands," and one called "Brands and their companies." And they're always pleased to receive a call for this kind of information. It's what they're there for. Try giving the reference librarian in your local library a call next time you have a question about who makes what brand of TV or VCR, or similar questions.

tified Electronics Technicians (ISCET): a VCR model number and parts cross reference. The Fifth Edition of the VCR Model Number and Parts Cross Reference is available in both paper and software editions from ISCET.

The software allows the user to search by manufacturer for model numbers and description for part numbers, and a sub-search by manufacturer and part description is also a feature of the program. The editing sequence for parts shows on

screen all the substitutes for the part entered. The book sells for \$29.95 plus \$3.00 shipping.

First time purchasers of the software can buy the program and data disks (one 3-1/2-inch disk or two 5-1/4-inch disks)

FCC ID numbers			
Manufacturer	First 3 Characters of FCC ID	Manufacturer	First 3 Characters of FCC ID
Advent Corporation	ATP	NEC	A3D
Akai	ASH	Orion	A7R
AOCInt'l of America Inc	ARR	Philips	BOU
Capetronic Int'l Corporation	ANV	Phone Mate	AAL
Carterfone	ADF	Phonotronics	ACB
Curtis Mathes	AFR	Radio Shack	AAO
Fisher	AFA	RCA	AHA
Funai	ADT	Samsung	A3L
GE	AJU	Sanyo	AEZ
Goldstar	BEJ	Sharp	AFL
Harman Kardon Inc	API	Sharp	ATA
Hitachi	ABL	Shintom	E0Z
JC Penney	ABW	Sony	AK8
Kenwood USA Corporation	ALI	Superscope Inc	AKC
Litton Microwave Cooking Products	AIH	Sylvania	AIX
Marantz Co Inc	AKE	Toshiba	AGI
Matsushita	ACJ	Uniden	AES
Midland International Corporation	AAY	Victor Company of Japan	ASI
Mitsubishi	BGB	Wells Gardner Electronics Corporation	ALA
Montgomery Ward	AGV	Yorx Electronics	ACA
Motorola	ABY	Zenith Electronics Corporation	ATO

Figure 2. To make it easier for readers who may be interested in locating the FCC ID prefix of a particular manufacturer, here is the same information presented in Figure 1, alphabetically by manufacturer name.



PTS Electronics



COMPUTER SERVICE

TV TUNERS/MAINBOARDS

★ **A+ CERTIFIED** 

★ **SYSTEM BOARDS**

★ **MONITORS**

★ **PRINTERS**

★ **TERMINALS**

★ **OVER 40 MAJOR BRANDS
IN STOCK MOST PRICED AT
\$49⁹⁵**

★ **1 YEAR WARRANTY**

★ **24 HOUR TURNAROUND**

★ **ZENITH MAINBOARDS**

★ **RCA CHASSIS THRU CTC 187**

★ **PHILIP PROJECTION BOARDS
...AND MORE!**

*Call
Today!*



*Thousands
in
Stock!*

Corporate Headquarters
5233 Hwy 37 South
Bloomington, IN 47401
800-844-7871

4941 Allison St #11
Arvada, CO 80002
800-331-3219

110 Mopac Road
Longview, TX 75602
800-264-5082

15042 Parkway Loop, Ste D
Tustin, CA 92680
800-380-2521



Circle (64) on Reply Card

Parts Express™

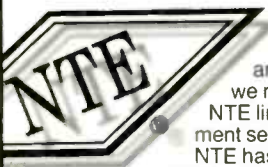

Parts Express is proud to announce that we now stock the NTE line of replacement semiconductors. NTE has been

supplying the electronics industry with top notch replacement parts for over 15 years. All NTE products meet or exceed industry specifications and offer an exclusive 2 year manufacturer warranty.

We also offer a complete line of parts for the service repair industry. Test equipment, loudspeakers, video and audio heads, magnetrons, belts, idler assemblies, tools, soldering equipment, just to name some of the 12,000 items we stock. Ask about our new dealer program for resellers. Call toll free for a copy of our **FREE** 212 page catalog. *Source Code: ESM*



**CALL TOLL FREE
1-800-338-0531**

Parts Express 340 E First St. Dayton, Ohio 45402-1257
Phone: 513-222-0173 Fax: 513-222-4644

Circle (65) on Reply Card



The Professional

Electronics Technicians Association

(A not-for-profit association of technicians)

Join Us

Regional Tech Seminars

Electronics Technology School, Satellite/Antenna/MATV, and Business Management Schools for small electronics service dealers

CET Certification

Become a **CET, Certified Electronics Technician**. Join those making a profession of the business. Call for nearest test site. (360 sites nationwide)

Employment Help

Members receive tips for resume preparation, notices of job openings and help on holding a job. Study materials for FCC Commercial licenses and CET.

317-653 4301
602 N Jackson
Greencastle, In 46135

Circle (56) on Reply Card

UL listing number to VCR manufacturer (Unofficial)

UL Number	Manufacturer	Brand Names
146C	Goldstar	
153L	NEC	
16M4	Samsung	Supra, Multitech, Unitech, Tote Vision, Cybrex, GE, RCA, Sears
174Y	Toshiba	Sears
238Z	Hitachi	RCA, GE, Penny, Pentax
270C	Sony	
277C	JVC	
282B	Sharp	
289X	Emerson	
333Z	Symphonic	Teac, KTO, Realistic, Multitech, Funai, Porta Video, Dynatech, TMK
336H	RCA	
347H	NAP	
43K3	Kawasho	
403Y	Fisher/Sanyo	Realistic, Sears
436L	Quasar	
439F	JVC	Zenith, Kenwood, Sansui
444H	Zenith	
44L6	TMK	Emerson, Lloyds, Broksonic
504F	Sharp	Wards, KMC
51K8	Portavideo	
536Y	Mitsubishi	Emerson, Video Concepts, MGA
540B	GE	
570F	Sony	Zenith
623J	Sampo	
628E	Samsung	MTC, ToteVision
679F	Panasonic	RCA, GE, Magnavox, Quasar, Canon, Philco
723L	Sanyo	
727H	Hitachi	
74K6	Funai	
781Y	NEC	Dumont, Video Concepts, Vector, Sears
828B	Panasonic	Olympus
843T	Magnavox	
86B0	Goldstar	Realistic, JC Penny, Tote Vision, Shinton, Sears, Memorex
873G	Mitsubishi	
41K4	Portland	

Figure 3. The UL listing number on a consumer electronics product identifies the manufacturer who made it. Here's a partial listing of UL numbers vs. manufacturer.

for \$69.95 plus \$2.00 shipping. Registered previous purchasers of the original program can purchase the upgrade for \$29.95 plus shipping.

A sixth edition book and disk with over 1,000 additional parts will be available by January 31, 1996.

The Cross Reference book or disk can be ordered from ISCET, 2708 West Berry, Fort Worth, TX 76109; Telephone: 817-921-9101.

This two-part reference will help any servicing organization that services VCRs to cross reference among different brands made by the same manufacturer. Part 1 of this reference will allow the user to determine when he has a product in for servicing, if it's possible that it's identical, or almost, to a product for which he already has a service manual. Part 2 of the reference cross references parts, so that if you can't find a part number for a prod-

uct you are servicing, you may find you have it on hand under a different part number for another manufacturer's product.

The FCC ID number can help you find a manufacturer

Most consumer electronics products carry clues as to who the manufacturer is. An FCC ID number, for example, appears on every VCR and computer, and any other product that might generate electromagnetic interference. Armed with this number, a technician may call or write the FCC:

Federal Communications Commission
1919 M Street, NW
Washington, D.C. 20463,

Give the ID number and ask for the name and address of the manufacturer. A

partial cross-reference list of manufacturer name vs FCC ID numbers is provided in Figure 1. Figure 2 is the same information in alphabetical order by manufacturer name.

A private company has downloaded this information and makes it available in the form of a compact disc. The address and telephone number for this company are:

M.I. Technologies
3310 E. Peterson Road
Troy, OH 45373
513-335-4560

Identification using the UL manufacturer's code number

Another source of manufacturer identification information is the Underwriters

Laboratories code number. The manufacturer of every product submitted to UL for certification is assigned a unique code number that identifies the manufacturer. Figure 3 is a partial list of UL numbers and the manufacturers they represent.

Locating the manufacturers

It's not unusual for a servicing organization to have some difficulty finding the address and telephone number of a manufacturer of a product for which they need to order parts, even when the manufacturer is well known. Figure 4 is a listing of manufacturers, gleaned from the Consumer Electronics Replacement Parts Sourcebook, the NESDA Professional Electronics Yearbook, ES&T reader correspondence, many telephone calls by the ES&T staff, and other sources. ■

Figure 4. Names and addresses of manufacturers.

Replacement parts source

Sometimes it's difficult to find parts or servicing information for a product, even if you know who the manufacturer is. This listing, gleaned from the 1991 Consumer Electronics Replacement Parts Sourcebook published by EIA/CEG, the 1991 Professional Electronics Yearbook & Directory published by NESDA/ISCET, and information otherwise developed by the ES&T staff, will provide you with some parts and technical literature sources for some products.

Acoustic Research (AR)

330 Turnpike Street
Canton, MA 02021
617-821-2300
Fax: 617-784-4102

Action TV

(American Action TV)
100 Exchange Place
Pomona, CA 91768
909-869-6600

We obtained this information from a technician who had called earlier asking if we had information on this company. This technician checked through Circuit City after seeing an ad for an Action TV on sale there. According to Action TV, they sell through truck stops and discount stores.

Adcom Service Corporation

11 Elkins Road
East Brunswick, NJ 08816
908-390-1130
Fax: 908-390-9152

AIWA America Inc.

800 Corporate Drive
Mahwah, NJ 07430-2048
201-512-3600
Fax: 201-512-3705

Akai American, Ltd. - See Mitsubishi

Alpine Electronics of America, Inc.

19145 Gramercy Place
Torrance, CA 90501
310-326-8000
800-421-2284
Fax: 310-782-0726

Altec Lansing Consumer Products

P.O. Box 277
Milford, PA 18337
717-296-4434
800-258-3288 (ext PA)
Fax: 717-296-2213

AmPro Corporation

(Replacement parts for Kloss Nova beam and Videobeam)
5 Wheeling Ave.
Woburn, MA 01801
Sales: 617-932-4800
Fax: 617-932-8756

AOC International

311 Sinclair Frontage Rd.
Milpitas, CA 95035
408-956-1070
Fax: 408-956-1516

3) Tech
5) Monitor

Apple Computer

20525 Mariani Ave.
Cupertino, CA 95014
408-996-1010
Fax: 408-996-0275

Aristo Computers Inc.

6700 SW 105th Ave., Suite 307
Beaverton, OR 97008
503-626-6333
800-3ARISTO

Atari Corp.

1196 Borregas Avenue
Sunnyvale, CA 94086
408-745-2000
Parts: 408-745-5501
Tech: 408-745-2166
Warr: 408-745-2051

Audio Technica U.S., Inc.

1221 Commerce Drive
Stow, OH 44224
216-686-2600
Fax: 216-688-3752

Audio Video Technologies Inc.

60 E. Ida
Antioch, IL 60002
708-395-6321

Audiovox Corp.

150 Marcus Drive
Hauppauge, NY 11788
516-231-7750
Fax: 516-434-3995

Barcus-Berry, Inc.
5381 Production Drive
Huntington Beach, CA 92649
714-898-9211
800-854-6481
Fax: 714-898-7962

Blaupunkt
2800 South 25th Avenue
Broadview, IL 60153
708-865-5200
Fax: 708-450-8554

BSR
C/O Warranty Central
8130 Remmett Ave.
Canoga Park, CA 91304
213-689-9188
This is the brand of the products sold by DAK, a catalog discount company. This company may now be out of business.

Canton North America, Inc.
915 Washington Avenue South
Minneapolis, MN 55415-1245
612-333-1150
Fax: 612-338-8129

Capetronics USA Inc.
150 East 58th St., 29th Floor
New York, NY 10155-2998
212-832-1331

Casio Inc.
570 Mt. Pleasant Ave.
Dover, NJ 07801
201-361-5400
Fax: 201-361-3819

Channel Master
Industrial Park Drive
Smithfield, NC 27577
919-934-9711
Fax: 919-989-6951

Chinon America, Inc.
615 Hawaii Ave.
Torrance, CA 90503
310-533-0274
Fax: 310-533-0274

CIE American, Inc.
2515 McCabe Way
PO Box 19663
Irvine, CA 92713
714-833-8445
Fax: 714-757-4488

Citizen American Corp.
Subsidiary of Citizen Watch Co.
2450 Broadway, Suite 600
Santa Monica, CA 90411
310-453-0614
Fax: 310-453-2814

Clarion Corp. of America
661 W. Redondo Beach Blvd.
Gardena, CA 90247-4201
310-327-9100
800-821-6693
Fax: 310-327-1999

Columbia Data Products
851 W. Hwy 436, Suite 1061
Altamonte Springs, FL 32714
407-869-6700

Commodore International Ltd.
1200 Wilson Drive
West Chester, PA 19380
215-431-9100
Fax: 215-431-9465

COMPAQ Computer Corp.
20555 SH 249
Houston, TX 77070
713-370-0670
Fax: 713-374-1740

Connecticut Microcomputer
568 Danbury Road
New Milford, CT 06776
203-354-9395
Fax: 203-355-8258
800-426-2872

Craig Consumer Electronics
12845 Artesia Blvd.
Cerritos, CA 90701-5001
310-926-9944
Fax: 310-926-9269

Curtis Mathes Corp.
2855 Marquis Drive #110
Garland, TX 75042
800-949-4999
Fax: 800-938-2808

Daewoo Electronics Corp. of America
100 Daewoo Place
Carlstadt, NJ 07072
201-935-8700
Fax: 201-935-6491

parts + service by

Dell Computer Corp.
2214 W. Braker Lane
Austin, TX 78758-4063
Sales/Parts/Warranties:
800-624-5150
Service: 800-624-9896

Denon America, Inc.
222 New Road
Parsippany, NJ 07054
201-882-7490
Fax: 201-575-1213

Design Acoustics
An Audio-Technica Company
1221 Commerce Drive
Stow, OH 44224
216-686-2600
Fax: 216-688-3752

Eastman Kodak
343 State St.
Rochester, NY 14650
716-724-4000

Electronic Systems Products, Inc.
525 N. John Rodes Blvd.
Melbourne, FL 32934-9103
407-269-6680
Fax: 407-267-6211

Electrophonic
This was a brand produced or sold by Pilot Audio Video Systems. See entry under Pilot.

Emerson Radio Corp.
9 Entin Road
Parsippany, NJ 07054
201-884-5800

parts FOX

Tech 800-388-8373

Epson America, Inc.
20770 Madrona Ave.
Torrance, CA 90503
310-782-0770
Fax: 310-782-5220

Fujitsu Ten Corp. of America
National Service Headquarters
19600 South Vermont St.
Torrance, CA 90502
800-423-8161

Funai USA Corporation
(Also Symphonic)
100 North Street
Teterboro, NJ 07608
201-288-2606
Fax: 201-288-0239

GE Appliances/Microwave Products Dept.

Appliance Park
Bldg. 4106
Louisville, KY 40225
502-452-3568

Gemini, Inc.

103 Mensing Way
Cannon Falls, MN 55009
800-533-3631
Fax: 507-263-4887

GoldStar Electronics Int'l, Inc.

201 James Record Rd.
Huntsville, AL 35824-0166
205-772-8860 *research*
Fax: 205-772-8987 *parts 800-221-0404*
6 hrs

Grundig/Lextronix Inc.

3520 Haven Ave., Unit L
Redwood City, CA 94063
415-361-1611
Fax: 415-361-1724

Harmon Kardon, Inc. - JBL

20630 Nordhoff Street
Chatsworth, CA 91311
818-727-0144
Fax: 818-829-0997

Heath Company/Heath-Zenith Consumer Products Group

PO Box 1288
455 Riverview Dr.
Benton Harbor, MI 49022
616-925-6000
Fax: 616-925-2898

Hewlett-Packard

3000 Hanover St.
Palo Alto, CA 94304
415-694-2000

Hitachi Home Electronics (America), Inc.

675 Old Peachtree Rd.
Suwanee, GA 30174
404-279-5600
Fax: 404-279-5692
Parts Center
401 West Artesia Blvd.
Compton, CA 90220 *FOX ONLY*
310-537-8383

INTV Corp.

3541 B Lomita Blvd.
Torrance, CA 90505
310-539-1940

International Jensen Inc.

25 Tri-State Int'l Ofc. Ctr., Ste 400
Lincolnshire, IL 60069
800-323-0221
Fax: 708-317-3826

JVC Service & Engineering Co. of America

Division of U.S. JVC Corp.
107 Little Falls Rd.
Fairfield, NJ 07004-2105
201-808-2100

Kawasho International

Kawasho is no longer importing TV sets into the U.S., but some parts and service information is available from:
Factory Service
PO Box 747
Buffalo, NY 14240
716-856-1612
Kawasho flybacks are also available from:
Electro Dynamics
(General line distributor)
135 Eileen Way
Syosset, NY 11791
800-426-6423

Computer Monitor Tester



Price:
\$295.00
+\$5.00 S&H

Includes battery, AC adapter, Mac adapter and 120 day warranty

There is no easier way to test and evaluate monitors than with the Checker 12

Finally, a low cost way of getting into the monitor repair business. Test and repair computer monitors with speed and accuracy. The "Checker 12" is an easy to operate, hand held, battery, or AC operated computer color monitor pattern generator. With its support of CGA (15.75khz), EGA (22khz) MACII (35khz), and VGA modes 1,2,3 (31.5khz) 800X600 (35khz, 1024X768 interlaced (35khz), 1024X768 non-interlaced & 1024X768NI with sync on Green (48khz), you can easily checkout a monitor in all of its' modes. With its' single mode switch, you know exactly what type of monitor you are testing. Its' front panel color pictures show just what you should be seeing on the monitor under test. You can quickly tell if the monitor is a VGA, SVGA, or a SVGA/NI. The "Checker 12" provides various test patterns for VGA monitors. X-hatch, for size and linearity and convergence set-up. White screen, for purity and CRT burn evaluation. Color bars and 8 step gray scale for color tracking and balance. There is also a single color mode that allows for single color channel operation.

Computer and Monitor Maintenance

1-800-466-4411 404-662-5633

We also have the Checker VI, a six port stand-alone VGA (640X480) test pattern generator, No computer required. Just \$249.95.

Circle (54) on Reply Card

Just your phone and an Andrews line card.

...and you have over 250,000 different parts in stock. Shipped the same day!*

AIWA	SONY	EMERSON
HITACHI	JVC	RCA*
OPTONICA	PANASONIC	PROSCAN*
QUASAR	SCOTT	GE*
SHARP	TECHNICS	TOSHIBA
	ZENITH	
	(*Premier)	

- Over a 90% Fill Rate
- No minimum orders
- Backorder reports with ETA's mailed biweekly
- No handling charges
- Free or Discounted freight program
- Fast, Efficient Research
- Factory Authorized

*Applies to orders received by 2:30 PST

Phone 800-289-0300 FAX 800-289-0301

ae andrews electronics P.O. Box 914, Santa Clarita, CA 91380-9014
Inquiries: 805-257-7700
FAX 805-295-5162

Stocking the Largest Inventory of O.E.M. Parts, Accessories, and Service Literature in the Country

Circle (51) on Reply Card

Kaypro Corporation

101 W. Broadway 3400
 San Diego, CA 92101-8205
 619-535-2155
 Fax: 619-535-2170

Kenwood U.S.A., Corp.

PO Box 22745
 Long Beach, Ca 90810-5745
 310-639-9000 *Parts 808-776-2626*
 Fax: 310-631-3913

Kloss Video Corp.

See Ampro Corp.

KTV Inc.

205 Moonachie Road
 Moonachie, NJ 07074
 201-440-9090
 Fax: 201-440-6557

Kyocera Electronics, Inc.

100 Randolph Rd.
 Somerset, NJ 08873
 201-560-0060

Lloyd's Electronics, Inc.

National Parts
 6500 West Cortland St.
 Chicago, IL 60635
 312-889-8870
 Fax: 312-889-6797

Luxman Electronics Corp.

915 Washington Avenue South
 Minneapolis, MN 55415
 612-333-1150
 Fax: 612-338-8129

Marantz USA

A Division of Bang & Olufsen of
 America, Inc.
 440 Medinah Road
 Roselle, IL 60172
 708-307-3105
 Fax: 708-307-2687

Matsushita Services Co.

50 Meadowland Parkway *Tech 201-392-4207*
 Secaucus, NJ 07094
 201-348-7000
 Fax: 201-348-7527
Merch, Parts 206-395-7343

Mattel, Inc.

See INTV

Micro Palm Computers

316 Daniel Webster Hwy.
 Merrimack, NH 03054-4115

Midland International Corporation

1690 North Topping
 Kansas City, MO 64120
 816-241-8500
 Fax: 816-245-1144

Mitsubishi Electronics America, Inc.

National Service Department
 5757 Plaza Drive
 PO Box 6007
 Cypress, CA 90630-0007 *Parts 800-553-2278*
 714-220-2500

NAD (USA) Inc.

633 Granite Court
 Pickering, Ontario
 Canada L1W 3K1
 905-831-6333

NEC Technologies Inc.

Consumer Electronics and Computer
 Products Divisions
 1255 Michael Drive
 Wood Dale, IL 60191-1094
 708-860-9500
 Fax: 800-356-2415

Nikko

AVS Technologies
 2100 Trans-Canada Highway South
 Montreal, Quebec
 Canada H9P-2N4
 514-683-1771
 Fax: 514-683-5307

Okidata

532 Fellowship Road
 Mount Laurel, NJ 08054
 609-235-2600
 800-OKIDATA

Onkyo U.S.A. Corp.

200 Williams Drive
 Ramsey, NJ 07446
 201-825-7950
 Fax: 201-934-1845

Orion Sales Inc.

11 Union Drive
 PO Box 10
 Olney, IL 62450
 618-392-7000
 Fax: 618-392-7100
 Service manager is Roy See

Ortofon, Inc.

65 East Bethpage Rd.
 Plainview, NY 11803
 516-454-6570
 Fax: 516-454-6515

Penney, J.C.

National Parts Center
 6840 Barton Road
 Morrow, GA 30260
 404-961-8408
 800-933-7115

Philips Consumer Electronics Company

Philips Service Company
 PO Box 555
 401 Old Andrew Johnson Highway
 Jefferson City, TN 37760
 615-475-8869
 Replacement Parts/Service Literature
 800-851-8885
 Fax: 800-535-3715

Pilot Audio Video Systems

Information available on this company is that it went out of business in about 1989. For a while some parts were available through Curtis Mathes, but now there is no source of parts or service literature for Pilot. If any readers have other information, please let us know. (See Electrophonic).

Pioneer Electronics Service, Inc.

1925 East Dominguez St.
 PO Box 1760
 Long Beach, CA 90801 *Tech 708-225-4550*
 310-835-6177
 Fax: 310-952-2923
Part 310-952-4200
42 parts 800-457-2201

Proton

Proton Parts Department
 16826 Edwards Road
 Cerritos, CA 90703
 310-404-2222
 Fax: 310-404-2322

Radio Shack

Business Products Support Services
 1801 S. Beach Street
 Fort Worth, TX 76105
 817-390-3011
 Radio Shack Business Products Parts
 1801 S. Beach Street
 Fort Worth, TX 76105
 817-870-5695

Ricoh Corp.

3001 Orchard Pkwy.
 San Jose, CA 95134
 408-432-8800

Rotel of America

54 Concord Street
 North Reading, MA 01864-2699
 508-664-3820
 Fax: 508-664-4109

Sampo Corporation of America

5550 Peachtree Industrial Blvd.
 Norcross, GA 30071
 404-449-6220
 Fax: 404-447-1109

Samsung Electronics America, Inc.

Service Division
 One Samsung Place
 Ledgewood, NJ 07852
 201-691-6200
 Fax: 201-347-8650

*FOT
 parts*

Sansui Electronics Corp.

Parts Department
 17150 South Margay Avenue
 PO Box 4687
 Carson, CA 90746
 310-604-7300

Sanyo-Fisher (USA) Corp.

Consumer Electronics Sales Div.
 21350 Lassen St.
 Chatsworth, CA 91311
 818-701-4175
 For Service: SFS Corporation
 1200 West Artesia Blvd.
 Compton, CA 90220
 310-537-5830
 Fax: 310-605-6699

*712
 Tech
 705-495-1524
 after
 2pm*

Scott, H.H. Inc.

5601 Westside Ave.
 North Bergen, NJ 07047
 201-662-2000
 Parts/Technical Literature:
 H.H. Scott, Inc.
 State Route 41 & County Rd. 100W
 Princeton, IN 47670
 800-695-0095
 Fax: 812-386-6502
 Tech. Serv.: 800-922-0738

Sears

333 Bevrly Road
 Hoffman Estates, IL
 708-286-5222

*parts
 800-366-7278*

Sharp Electronics Corp.

Sharp Plaza
 PO Box 650
 Mahwah, NJ 07430-2135
 201-512-0055
 Fax: 201-512-3456

Sherwood/Inkel Corporation

14830 Alondra Blvd.
 La Mirada, CA 90638-5730
 714-521-6100
 Fax: 714-521-4900

Shintom West Corp. of America

20435 S. Western Ave.
 Torrance, CA 90501
 310-328-7200

Shure Brothers, Inc.

222 Hartrey Avenue
 Evanston, IL 60202-3696
 Service: 708-866-5732
 Fax: 708-866-2551

Signet

1920 Enterprise Parkway
 Twinsburg, OH 44087
 216-963-5959
 Fax: 216-425-9339

**Sony Corp. of America/
 Sony Service Company**

Sony Drive (T1-12)
 Park Ridge, NJ 07656
 201-930-1000

*NO
 Tech*

Sony National Parts Center

8281 N.W. 107th Terrace
 PO Box 20407
 Kansas City, MO 64153
 816-891-7550

Soundcraftsmen, Inc.

4545 E. Baseline Road
 Phoenix, AZ 85044-5306
 714-556-6191
 Fax: 714-662-0750

SDI Technologies

(Formerly Soundesign Corporation)
 800 Federal Blvd.
 Carteret, NJ 07008
 908-855-0220
 Fax: 908-855-0224

Sparkomatic Corporation

P.O. Box 277
 Milford, PA 18337
 717-296-6444
 800-233-8831 (Nationwide)
 800-592-8891 (In PA)

Studor Revox America, Inc.

1865 Air Lane Drive #12
 Nashville, TN 37210-3814
 615-391-3399

Symphonic Corp.

(Also Funai)
 100 North St.
 Teterboro, NJ 07608
 201-288-2606

Tandberg

Tandberg was a manufacturer of audio equipment. Latest information available is that they are out of business both in the U.S. and in Europe.

Tandy Consumer Service Parts

7439 Airport Freeway
 Ft. Worth, TX 76118
 817-284-8691
 800-243-1311
 Fax: 817-284-1961

Tandy National Parts

900 East Northside Dr.
 Ft. Worth, TX 76102
 817-870-5600
 800-442-2425

Tatung Company of America, Inc.

2850 El Presidio St.
 Long Beach, CA 90810
 213-979-7055

TEAC Corporation of America

7733 Telegraph Rd.
 Montebello, CA 90640
 213-726-0303
 Fax: 213-727-7656
 Parts Orders: 213-726-0303
 Fax for Parts Orders: 800-366-8868

Technics

See Matsushita

Teknika Electronics Corp.

A subsidiary of Fujitsu, Ltd.
 Parts Department
 353 Route 46 West
 Fairfield, NJ 07004
 201-575-0380
 Fax: 201-575-7311

Teledyne

See Acoustic Research

Thomson Consumer Electronics

10330 N. Meridian Street
 P.O. Box 1976
 Indianapolis, IN 46290-1024
 317-587-3000
 Fax: 317-587-6759



Thomson Consumer Electronics
 Distributor and Special Products
 Division
 2000 Clements Bridge Rd.
 Deptford, NJ 08096
 609-853-2241
 For Servicing Literature:
 TCE Publications
 10003 Bunsen Way
 Louisville, KY 40299
 502-491-8110

*Tech
 913-541-0402*

**Toshiba America Consumer
 Products Inc.**
 National Parts Center
 1420-B Toshiba Dr.
 Lebanon, TN 37087
 615-449-2360
 Fax: 615-444-7520
Tote Vision
 969 Thomas St.
 Seattle, WA 98109
 206-623-6000
 Fax: 206-623-6609
 Parts Fax: 206-343-9029

Unisonic Products Corp.
 16 West 25th Street
 New York, NY 10010
 212-255-5400

Videonics
 1370 Dell Ave.
 Campbell, CA 95008
 408-866-8300

V-M Corporation
 The Voice of Music
 305 Territorial
 PO Box 426
 Benton Harbor, MI 49023
 616-925-8841

This company no longer manufactures product, but manufactured large numbers of turntables under their own name, and for use in audio products of other manufacturers. If you ever need parts for a turntable that has 857 for the first three digits of the serial number, this is the company to contact. If you have any parts for these turntables, V-M corporation would like to talk to you about buying them.

Wells-Gardner Electronics Corp.
 2701 North Kildare Avenue
 Chicago, IL 60639
 312-292-5643
 Fax: 312-252-0925

Yamaha Electronics Corp. USA
 Parts Department
 6660 Orangethorpe Ave.
 Buena Park, CA 90620
 714-522-9105
 Fax Orders: 800-634-0355

Yorx Electronics Corp
 200 Executive Drive, Suite 130
 West Orange, NJ 07052
 201-736-9555
 Fax: 201-736-8180

Zenith Data Systems
 2150 East Lake Cook Road
 Buffalo Grove, IL 60089
 708-808-4584

**Zenith Electronics Corp./
 Videotech Corp.**
 1900 North Austin Ave.
 Chicago, IL 60639
 312-745-2000
 Service: 312-745-5170

Troubleshooting Tips

Sylvania Model CLB536AR03 Chassis E51-46 No Sams Photofact

By Dudley Overton

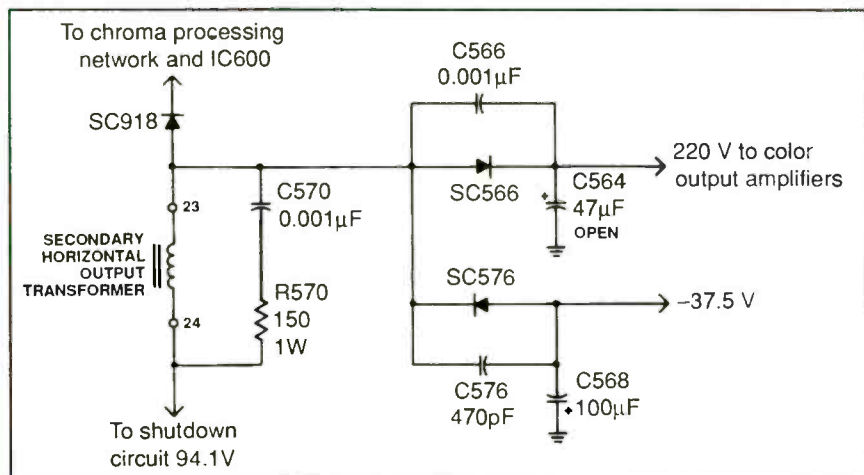

This set was brought into the service center with an unusual symptom. The sound was normal, but there was no video, and a narrow dim raster occupied the right one-third of the screen. A one-inch-wide blue line bordered the left side of the raster. I suspected a dual fault; i.e., horizontal foldover, or a rare yoke problem, plus loss of video. But loss of video was the only fault.

The 110V regulated supply and the high voltage checked normal. But the 220V supply, which is derived from the horizontal output transformer, was down to 39V. This essentially cut off the three color amplifiers and their regulators.

In this set, the secondary of the horizontal output transformer develops a 250V peak, 5µS positive pulse at point 23. This pulse passes through diode SC566 and is

filtered by capacitor C564. After filtering, the pulse is down to 1.2V, or less than 0.006% of the 220V developed.

Experience suggested that one of three faults could possibly reduce the voltage at point 23 from the normal 220V to 39V:

- a short circuit in one of the color output amplifiers (these are high-power transistors with TO202 cases, capable of dissipating 10W each),
- a shorted diode, or
- a faulty filter capacitor.

The diode and the color output transistors checked good using the continuity test function on my DMM.

Continuing to trace the 220V supply circuit led me to filter capacitor C564. When I unsoldered the capacitor and lifted it from the PC board, I found stains on the circuit board beneath it. I tested C564 with the capacitor tester, which revealed that it was open. Normal operation resumed when the capacitor was replaced.

Overton is an independent servicing technician

SCR "chopper" regulators and shutdown circuits

By Steven Jay Babbert

The SCR (silicon-controlled rectifier) was introduced by General Electric in 1957. By 1960 it had largely replaced its vacuum tube and mechanical (relay) counterparts in power control applications. The SCR is a member of the thyristor family, a group of semiconductor devices which can be made to switch heavy currents in response to low-voltage control signals.

The most outstanding feature of the SCR is its ability to remain in the conduction mode, even after the control voltage is removed. Engineers have found several ways to utilize this feature in the design of television receivers. In this article, we will look at SCR basics, and then we will see how and why they are used in television receivers.

SCR operation

The SCR is a three-terminal semiconductor device consisting of an anode, a cathode and a gate (Figure 1). Notice the symbol's resemblance to that of a diode. Like the diode, the SCR is a unilateral device, meaning that it will pass current in one direction only. "Conventional current" flow is from anode to cathode.

Transistors have "transfer" characteristics, which means that their conduction level can be varied by varying the control (base) signal voltage. This is how they are used in amplifiers. They can also be turned fully "on" by the application of a large enough control voltage and "off" by removal of the voltage. Most TV switching or "chopper" regulators and horizontal output circuits use them in this way.

SCRs, on the other hand, have none of the transfer characteristics of transistors and can not be used for amplification. However, they can be used instead of transistors in certain switching applications. SCRs are turned fully "on" when the gate-to-cathode voltage exceeds a specified threshold voltage or trigger voltage (V_t).

Once triggered, the device is said to be

Babbert is an independent consumer electronics servicing technician.

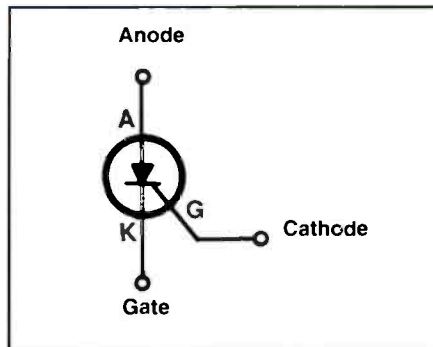

Figure 1. The SCR is a three-terminal device consisting of an anode, a cathode and a gate. Notice the resemblance of this symbol to the symbol for a diode.

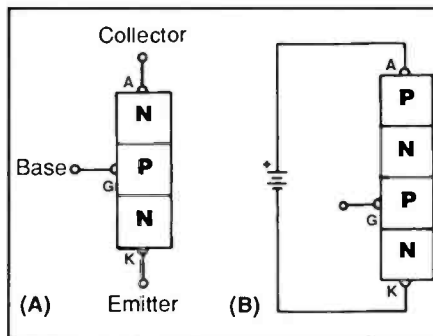

Figure 3. Notice the similarity between the simplified model of a junction transistor (a) and the simplified model of an SCR (b).

"latched" and will remain in the conduction mode even after the gate voltage is removed. In order for the SCR to turn "off," the current flow from anode to cathode must be reduced below the device's "holding" value (I_h). This must be done by another device in series with the SCR (Figure 2). When the anode voltage rises again after turn-off, the SCR will block current flow until it is re-triggered.

Physical construction

Like the bipolar junction transistor, the SCR basically consists of a number of layers of doped silicon. These layers form a series of P-N junctions. Junction transistors have three layers whereas SCRs have four (Figure 3). Based on the volt-

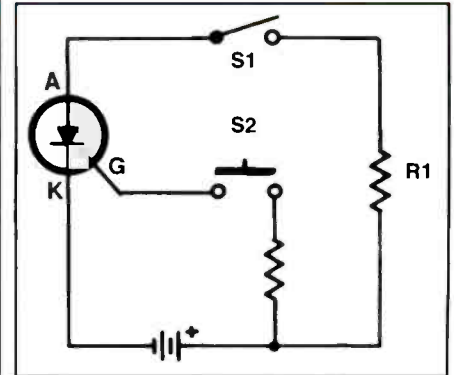

Figure 2. With SW1 closed, a momentary contact of SW2 will trigger the SCR. When SW2 is opened, conduction will cease. Another trigger pulse will be needed while SW1 is closed to put the SCR back into conduction.

age gradient from top to bottom, junctions one and three will tend to be forward biased while junction two tends to be reverse biased (blocking).

If the P-type layer of junction two is made more positive than the N-type layer by the application of a positive gate voltage, junction two will begin to pass current. This model is too simplified to illustrate how latching occurs; suffice it to say that, once the SCR is triggered, internal conversion processes within the semiconductor material give rise to a regenerative "latching" action.

Linear versus chopper

Earlier TV power supplies used "linear" regulators. In these designs, the resistance of the series-pass transistor is adjusted by a control circuit to maintain regulation. By "series-pass" we mean the work-horse component that actually passes current from the input of the regulator circuit to the output. Though these supplies work well, they waste power in the form of heat that is produced as the current passes through the resistance.

In the "chopper" or "switching" regulator, the series-pass transistor is switched on and off by a control circuit, producing pulse width modulation. Since transistors have the least resistance when they are solidly "on" (saturated) they produce less

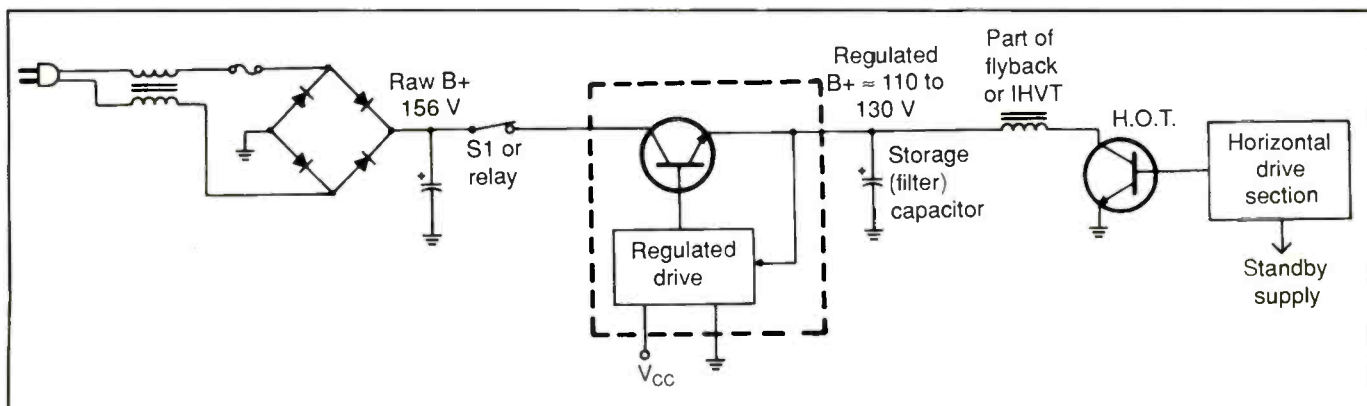

Figure 4. In most "chopper" regulator designs, the raw B+ is applied directly to the "pass" transistor. The pass transistor is switched on and off by the driver circuitry.

heat in the switching mode. For this reason, chopper regulators are more efficient.

Figure 4 shows a typical chopper circuit using a transistor. The raw B+ (usually around 156V) is chopped and then averaged into the regulated B+ (usually between 110V and 130V) before it is applied to the horizontal output circuit. The basic B+ path is no different than it is in a chassis using a linear regulator.

SCRs are also used as the "pass" element in TV power supplies. Their triggering circuits are simple because they only require a momentary turn-on pulse. Transistors and MOSFETs require a specific bias voltage which must be maintained as long as the device is to be held "on."

SCR power supply circuitry is somewhat complicated because of the "latching" characteristic; they can't be switched off by the driver circuit. In this type of supply, the raw B+ from the bridge rectifier is passed through a separate winding on the flyback or IHVT (integrated high-voltage transformer) before being applied to the anode of the SCR (Figure 5). This can be confusing to technicians who are used to seeing the more direct raw B+ path used in non-SCR supplies.

A note before we continue: some high-end televisions employ another kind of switching power supply that uses a transformer. In these supplies, a pass-transistor (usually a MOSFET) pulses current through the primary winding. This square-wave ac induces secondary voltages which are rectified and fed to their respective circuits. These are much more complex than the basic switching or chopper circuits described here.

The SCR is switched off when its anode-to-cathode voltage is reduced by

the negative-going transition of the horizontal output pulse. The holding current (I_H) is interrupted just long enough for the device to switch off. The "hot" pulse is inverted and impressed onto the raw B+ by the turn-off winding. This turn-off action occurs at the horizontal rate (15,734.26 Hz) and at the same point in each cycle. Since the turn-off time is fixed, the only way to modulate the pulses is to control the turn-on time. This is the job of the driver circuit.

Older switching regulator driver circuits used discrete components. In some cases the circuit boards were large and servicing was often difficult. Recent designs contain most of the driver circuitry in a single IC. These ICs seem to hold up well even when the SCR fails.

The voltage comparator

The central block of most chopper regulator driver circuits is the voltage comparator. Voltage comparators are typically built around an op-amp.

For readers not familiar with op-amp basics, here is a brief description of op-amp operation. The output goes high (near Vcc) when the non-inverting (+) input is higher than the inverting (-) input. If the (-) input goes higher than the (+) input, the output goes low (near ground).

Lets look at a simplified SCR driver circuit (Figure 6). The (+) input of the comparator is held fixed by a stable reference voltage developed across a Zener diode. The (-) input is tied to an adjustable voltage divider connected between the output of the voltage regulator itself and

The linear regulator

In linear regulators, sometimes referred to as "series-pass: regulators," the conduction of a transistor, from emitter to collector, is controlled by controlling the base bias voltage. In effect, the emitter-to-collector resistance is adjusted to maintain the desired voltage drop. The base control circuit could be a simple zener diode and resistor combination. A comparator based driver circuit will provide tighter control, however.

Linear regulators work well in televisions but they have a drawback: they waste power in the form of heat which is produced as current passes through the emitter-to-collector resistance. This necessitates the use of large heat sinks. This inefficiency increases as the voltage drop

across the device and the current passing through the device increases.

Let's assume that a linear regulator is being used to reduce 156V (raw B+ in televisions) to 112V. This means that the transistor will have to drop the difference of 44V. Assume also that the chassis is drawing 0.5A. Based on Ohm's law, the emitter-to-collector resistance will have to be 88Ω ($R=E/I$). Since $P=IE$, the transistor will dissipate 22V.

In some television chassis, part of the load was taken from the transistor by shunting it with a resistor (often 220Ω). The total heat produced between the two was still the same. It was this inefficiency that led to the development of the switching regulator circuit.

ground. The B+ adjust control is part of this divider circuit.

The voltage divider is designed so that when the B+ adjust control is centered, the (-) input voltage will match the (+) input, or reference voltage, when the regulated B+ is correct.

When the regulated B+ drops, the (-) input will fall below the (+) input causing the comparator's output to toggle high. This will trigger the SCR into conduction which will raise the B+. By now, many readers will have noted that this constitutes a loop.

A storage capacitor at the output (cathode) of the SCR integrates the pulses into an average regulated B+ voltage plus or minus half the value of the ripple voltage. Figure 7 shows the relationship between various loading conditions and the corresponding pulse widths. Heavier loading results in earlier turn-on.

When the SCR switches off, the storage capacitor is isolated from the raw B+. When the horizontal output transistor switches on, it begins drawing current from the capacitor. Once the capacitor's voltage allows the comparator's (-) input to drop below the (+) input, the SCR is switched on. As soon as the B+ begins to rise, the comparator changes state, pulling the gate low once again.

Since the SCR is now latched, it will continue to refresh the charge on the storage capacitor until the turn-off pulse arrives. This charge is simultaneously being depleted by the horizontal output circuit. The IHVT's secondary loads are reflected into the primary and make up part of the total load. The amount of current drawn from the capacitor during each cycle will determine the switch-point.

Another factor which will influence pulse width is the level of the line voltage. Low line voltage results in lower raw B+ and subsequently lower amplitude refresh pulses. This has the same effects as heavier loading. The pulse width is increased to compensate.

Open-collector output

In order for the SCR to be triggered, the gate must be made positive with respect to the cathode, which is held at the regulated B+ voltage level. Most ICs can't produce an output voltage that is higher than their Vcc value. This problem is overcome by using "open-collector"

output circuitry in the driver.

In open-collector design, the collector of the output transistor is brought outside of the IC without being connected to any component within. The emitter is tied to ground (Figure 8). An external "pull-up" resistor ties the collector to some positive point in the circuit.

When the transistor is turned on, the collector will be pulled close to ground. When the transistor is turned off, it be-

comes a high impedance, allowing the output to be pulled up by the resistor. In the case of the SCR driver, the resistor will be tied to the raw B+ supply.

The SCR's gate is also connected to the open-collector output. When the transistor is on, the gate is held near ground. When the transistor is turned off, the gate is allowed to be pulled high by the resistor, triggering the SCR. The resistor's value is made high to limit current

ES&T READER SURVEY

It's a mini survey about you.

Bound into this issue is the ES&T Reader Survey card.

We would like to hear about the problems you face, the opportunities you see and the equipment you use during the course of your work day.

The postage is paid. All you have to do is fill it out and mail it.

What could be easier?

Please fill yours out and mail it today.

NEW 1996 Catalog

✓ Test Equipment ✓ Tools/Tool Kits
✓ Cases/Shipping Containers
✓ Solder/Desolder/Rework Stations
✓ Bench Accessories . . . and more!

For quality service & products, 100% satisfaction guaranteed, technical support, free shipping and many other benefits - Request your free catalog today.

800-426-1194

JENSEN® 7815 S. 46th St., Phoenix, AZ 85044
Ph: 602-968-6231 FAX: 800-366-9662

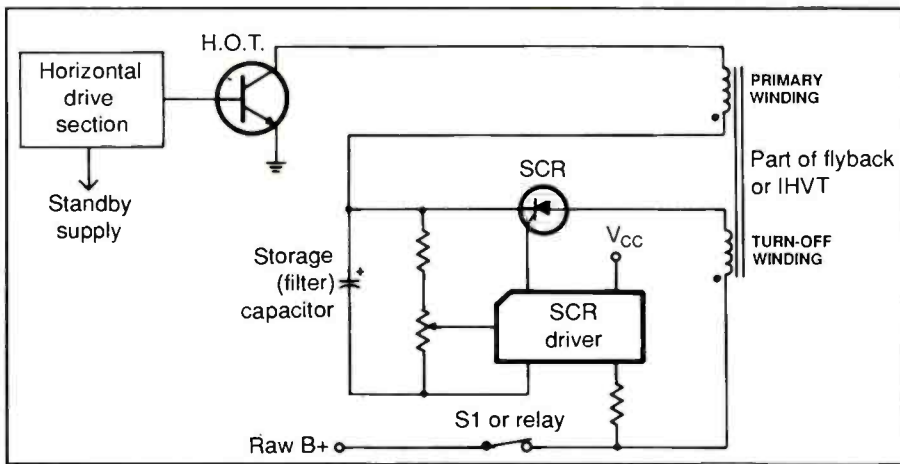

Figure 5. In the SCR design, the driver circuitry turns on the SCR but the turn-off winding provides the turn-off pulse.

through the transistor when it is on. Many analog and digital ICs use open-collector output circuitry.

X-ray protection

When a substance is bombarded by a stream of electrons traveling at a high enough velocity, X-radiation is produced. In CRTs, X-rays are produced when the electron stream from the cathode hits the positively charged phosphor. At some point it was determined that unacceptable levels of this potentially hazardous radiation could be emitted from color CRTs if the high-voltage became excessive. For this reason, the "high voltage shutdown" or "X-ray protection" circuit was created.

Though different methods have been used, many of the high-voltage shut down designs of the '70s and '80s used an SCR. It was connected between the base of the horizontal driver transistor and ground (Figure 9). If the SCR is triggered into

conduction, the low-level horizontal drive pulses will be shunted to ground, shutting down the chassis.

Since the SCR latches once it is triggered, the chassis won't start again after the high-voltage drops. If such a situation were allowed to continue, the repeated start-up/shutdown cycling and the resulting current surges could cause serious damage in a short time.

The most common cause of excessive high-voltage in TVs is excessive low-voltage. Shorted "pass" transistors, or SCRs in the low voltage power supply pass the raw B+ (usually around 156V) to the collector of the horizontal output transistor via the IHVT primary winding. This results in increased primary voltage and a subsequent increase in high-voltage and all secondary "scan - derived" voltages. For this reason, the regulated B+ voltage is monitored in most X-ray-protect circuit designs.

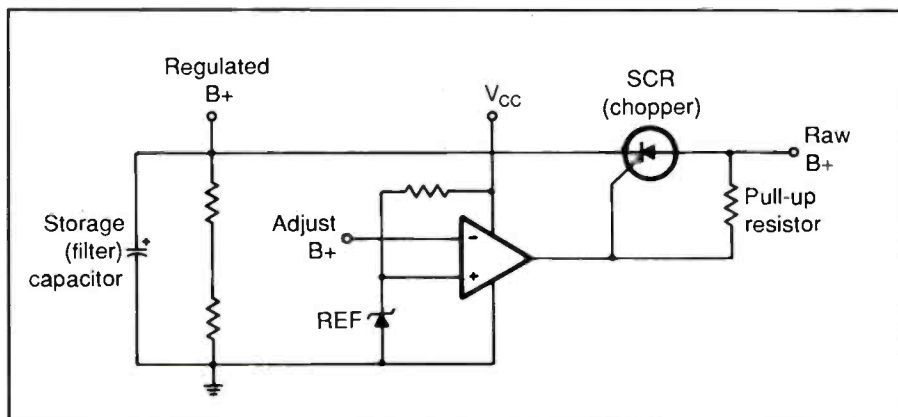

Figure 6. This simplified SCR driver circuit uses a voltage comparator which compares the value of a percentage of the regulated B+ to that of a stable reference voltage.

A large value zener diode is connected between the SCR's gate and the point being monitored. This could be the regulated B+ or a sample derived from a voltage divider. The zener is chosen to have a "breakover" voltage slightly higher than that of the point being monitored under normal conditions. When the voltage at this point increases due to a fault, the zener will conduct, thus driving the SCR's gate positive.

The horizontal resonant circuit

Another less common cause of excessive high-voltage is the detuning of the horizontal output resonant circuit. This tuned circuit consists mainly of the inductance of the deflection yoke and IHVT windings, and the capacitance of the "hold-down" capacitor. If this capacitor opens or drops in value, the retrace pulse will be shorter in duration and higher in amplitude. This will cause the high-voltage to increase.

As an experiment, I once powered up a chassis with the hold-down capacitor removed and the shutdown circuitry disabled; I wanted to see how high the voltage would go. The voltage arced from the second-anode connection on the side of the CRT to the outer Aquadag coating. There was no way to measure it under these conditions. This experiment was dangerous. It was not a good idea, and I don't recommend that anyone else try it.

Some chassis use a special device known as a "safety capacitor" in this circuit. Though it consists of a single capacitor, it has four legs (Figure 10). Each pair of legs is actually a jumper that makes connection to one side of the cap. This capacitor is situated in the circuit so that if it is removed, the B+ path will be broken to the horizontal output transistor. The set won't run if it is removed, hence the name "safety capacitor."

Excessive high-voltage caused by a problem in the horizontal output section will not change the regulated B+; however, the scan-derived voltages will be affected since they're derived from the IHVT. The level of these secondary voltages tracks the level of the high-voltage and therefore can be used by the shutdown circuit. This eliminates problems which could arise from trying to monitor the high-voltage directly, (this voltage is often over 25,000V).

In one system, a sample of the scan-

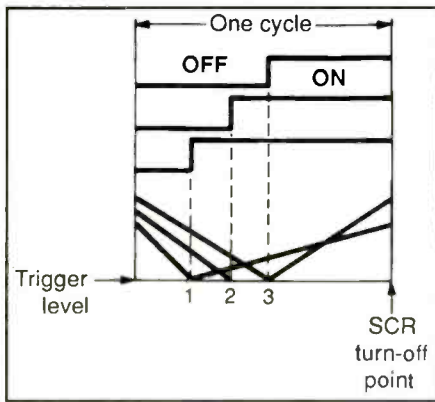

Figure 7. This diagram shows the relationship between the sawtooth waveform at the storage capacitor and the corresponding pulse width for various loading conditions. Waveforms one, two and three correspond to heavy, medium, and light loading respectively.

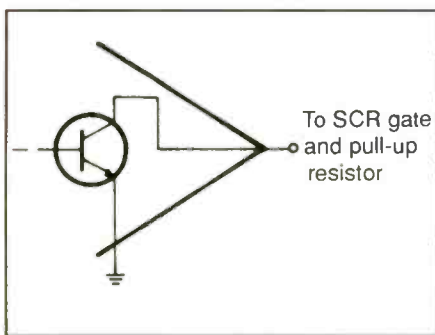

Figure 8. In open-collector output circuitry, when the output transistor is switched off, the collector becomes a high impedance to ground. In this case it will allow the SCR's gate to be pulled high via the pull-up resistor.

derived CRT filament voltage is rectified and filtered into an average dc value. This voltage is applied to the cathode of a zener diode. The anode is connected to the shutdown SCR's gate. The principle is the same as that used to monitor the B+. By following the traces from the SCR, you should be able to determine what voltages are being monitored.

Other high voltage shutdown systems use a transistor pair configured so that it will latch. Still others contain most of the shutdown circuitry within the horizontal processor IC. These circuits work in essentially the same way, they both monitor voltage levels at one or more points.

SCR regulator problems

The most common SCR failure in television circuits is the anode to cathode (A-K) short. This results in the raw B+ being passed to the horizontal output section, raising the high-voltage and causing shutdown. This type of problem is usually evi-

denced by an audible rush of high voltage when the set is turned on, followed by immediate shutdown.

When I encounter this kind of problem I power up the chassis at reduced line voltage (usually between 70Vac and 80Vac) by using a variable transformer. If the chassis uses a relay, the line voltage will have to be above the point at which the relay will hold. Then, while monitoring the regulated B+, I slowly increase the ac voltage output of the variable transformer. If the regulated B+ fails to level off at its specified value as the input voltage rises, I suspect a shorted SCR. During this test the set will go into shutdown when the specified B+ is exceeded by a few volts.

The SCR can be checked in-circuit for an A-K short with a DMM. If no short is found, check the driver circuit. A defective driver IC could allow the SCR's gate to be pulled high constantly. In this case the SCR will re-trigger as soon as the turn-off pulse ends; the duty-cycle will approach 100%, mimicking a short.

Driver circuit problems are not limited to the driver IC. A defect in the voltage divider (which includes the B+ adjust control) can give the IC improper feedback. This will cause the IC to overdrive or underdrive the SCR.

If the SCR is open there will be no regulated B+. In some chassis the SCR is shunted by a resistor which will pass enough current to allow the set to run even if the SCR is removed. In this case,

although the set will operate, the raster will be reduced in size and brightness.

Overloaded SCR

If the SCR is open, it is a good idea to check the circuits that it supplies; particularly when the fuse is blown. A low resistance measurement from the regulators output to ground will reveal that the SCR was being overloaded. In this case the most likely cause is a shorted horizontal output transistor. Other shorted components tied to the B+ line such as the IHVT or storage capacitor can overload the regulator. Check the schematic for all possibilities. Occasionally SCRs just fail from age and fatigue.

If you want to check the general condition of a chassis before replacing an SCR, use the bypass method (use this method when you're reasonably sure that the chassis will run). With the SCR removed, place a jumper between the anode and cathode connections on the board. Power the set with reduced voltage just as you would if the SCR was shorted. Monitor the B+ and bring up the line voltage until it is correct. Look at the picture for any signs of a defective circuit.

Problems in sections using the scan-derived (IHVT secondary) voltages won't upset the resistance measurements made at the regulator's output because they're isolated by the IHVT; however, they will load the regulators indirectly via the IHVT when the set is running. Leaky

Phase control

SCRs are often referred to as "phase control" devices. This arises from the fact that they can be switched "on" during a specific phase of the ac cycle when used to control ac current flow. By controlling the switch-point, the average power to the load is controlled.

Since it is a unilateral device, the SCR will only conduct during one half of the ac cycle; which half depends on the polarization of the device. The holding current (I_H) will be interrupted at the zero-crossing point of each cycle causing the SCR to turn off.

SCRs are often used in industrial applications for controlling power to large motors and other machinery. The trigger circuitry could be of the servo type

in which the trigger phase is adjusted in response to feedback from the machinery; or the trigger circuitry could be controlled by a simple operator-adjusted potentiometer. Figure A shows the portion of the ac sine wave which will be passed to the load for various triggering angles.

If two SCRs are connected in inverse parallel, both halves of the cycle will be passed. In this case the gate trigger pulses will have to be of alternating polarity. The triac is just such a device. It uses range from industrial applications to household dimmer switches. Figure B shows the symbol for the triac along with its equivalent circuit.

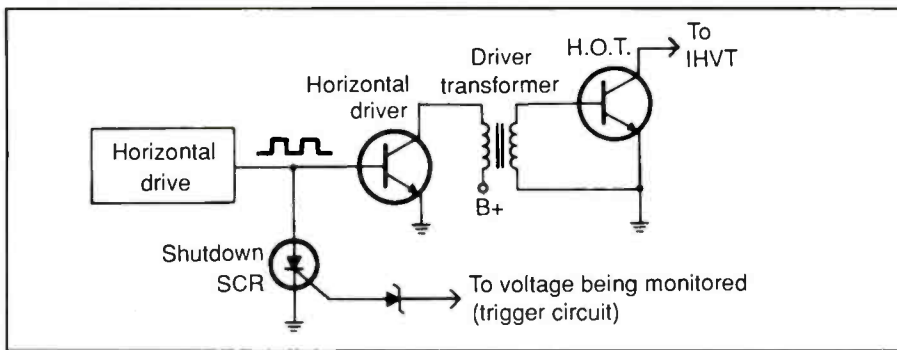

Figure 9. In the SCR-type shut-down circuit, once the monitored voltage rises above the zener diode's break-over point, the SCR will be triggered. It then provides a low resistance path to ground, shorting the drive pulses.

or shorted output transistors or ICs in vertical color, audio amps, or other circuits can cause this type of problem, often without blowing the fuse.

Bear in mind that an overloaded secondary supply puts stress on the horizontal output transistor too. Avoid running the set for very long under such a condition. Make resistance measurements from the IHVT secondaries to ground. A shorted electrolytic "filter" could cause more than one section to be inoperative.

Just as in the case of the SCR that seemed to be shorted, a malfunctioning

SCR horizontal output circuits

In the early '80s several manufacturers tried using SCRs in the horizontal output sections. The horizontal output transistor and damper diode were replaced by two SCRs. These were designated "trace" and "retrace." Though this design worked well, it was abandoned in favor of the conventional design because many technicians didn't understand it.

driver circuit can make an SCR appear open. If the SCR won't turn on, measure the gate voltage. If it is positive with respect to the cathode, it should be "on." If the gate is negative with respect to the cathode, check the driver circuit.

Sometimes a chassis will seem to be in shutdown, when actually it has stalled for some other reason. A loss of horizontal drive, though not the same as forced shutdown, has the same end result. It can be difficult to differentiate between the two, particularly if the problem is intermittent.

Shutdown verification

If you want to verify that a chassis is in shutdown, measure the SCR's anode-to-cathode voltage. If it is less than 1V, the SCR has been triggered. In this situation, the easiest way to troubleshoot is to disable the shutdown circuit and try to locate the source of the problem while the set is running at a reduced voltage.

Manufacturers instructions vary, but in most cases they recommend opening the gate circuit one way or another. Usually you can wick the solder from the gate lead. Some chassis use a plug-in SCR

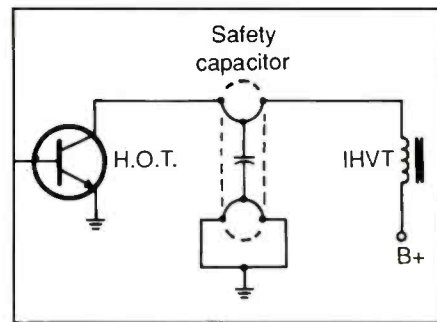

Figure 10. The "safety cap" has internal jumpers which complete the B+ path to the horizontal output transistor. Sets using this type of hold-down capacitor won't run without it.

which can be removed. Once the circuit is disabled, monitor the high-voltage and the regulated B+ simultaneously while gradually increasing the line voltage.

If the high-voltage goes excessive before the low-voltage reaches its rated value, suspect a problem in the horizontal output circuit. If the high-voltage doesn't go excessive until the low-voltage becomes excessive, suspect a problem in the low-voltage supply. If the high-voltage and low-voltage level-off properly and remain so as the line voltage is brought up to normal, the shut-down circuitry must be faulty.

If opening the gate circuit won't allow the set to run, but removing the SCR entirely does, then the SCR must be shorted. Shorted zener diodes in the gate trigger circuit will cause the SCR's gate to be pulled high constantly. These circuits are generally reliable but they can fail. If you work on one, be sure to follow the shutdown test procedure when you are finished. The shutdown test procedure will be found in the service literature.

Summary

SCRs and other discreet devices are rapidly giving way to four and five terminal voltage regulators in low-voltage power supplies. X-ray protection circuits have been swallowed up by TV-in-a-chip ICs along with the horizontal, vertical, chroma, luma and sound processor blocks. There are, however, still millions of sets in use utilizing one or more SCRs.

Knowing how these devices function, and how they differ from transistors will be helpful when you encounter them during troubleshooting. Furthermore, by studying these devices in their actual circuits, we gain a greater understanding of various related principles and concepts. ■

DALBANI
the ultimate saving source

Electronic Components is our business

FREE CATALOG

DALBANI CORPORATION
4225 N.W. 72 ND. AVE. MIAMI, FLOR DA. 33166
TEL : (305) 716-1016 FAX : (305) 594-6588

Circle (55) on Reply Card

Troubleshooting a Citizen JCTV3049X Television

By Ron C. Johnson

A few years back, when I was still trying to keep the wolves away from the door by fixing anything and everything electronic, I came to a painful conclusion: it isn't enough to be able to find and fix a problem, eventually you have to find and fix that problem profitably.

Johnson is a journeyman electronics servicing technician and an instructor of technology at the Northern Alberta Institute of Technology in Edmonton, Alberta, Canada.

The former experience can certainly be rewarding in terms of professional pride and sometimes it can save a valuable customer relationship, but it's rarely a money maker. The latter situation, of course, has to be the rule, the former must be the exception to the rule.

These days I put food on the table by teaching (which is a bit safer because if it takes a long time to get the job done I can

just blame it on the student!). But, I try to keep my hand in servicing enough to stay current and not forget what it's like for all of you guys out there on the front lines. (And I don't mind making a couple of bucks from the odd repair, if I can make it pay. Little did I know this time. . .).

That's what this article is about, one of those repair jobs I took on in my spare time which reminded me again what it

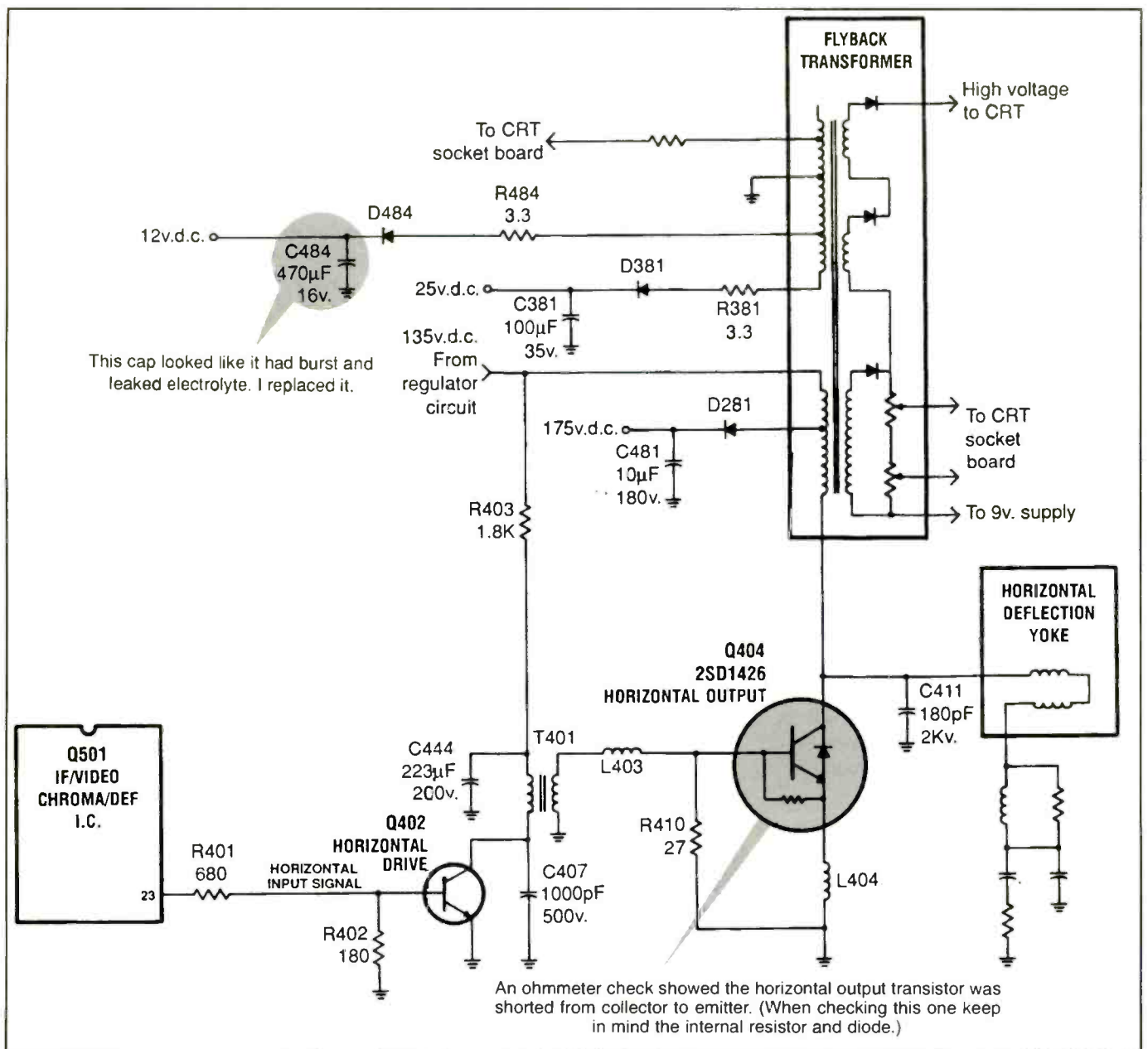

Figure 1. The horizontal output section of a Citizen JCTV3049X.

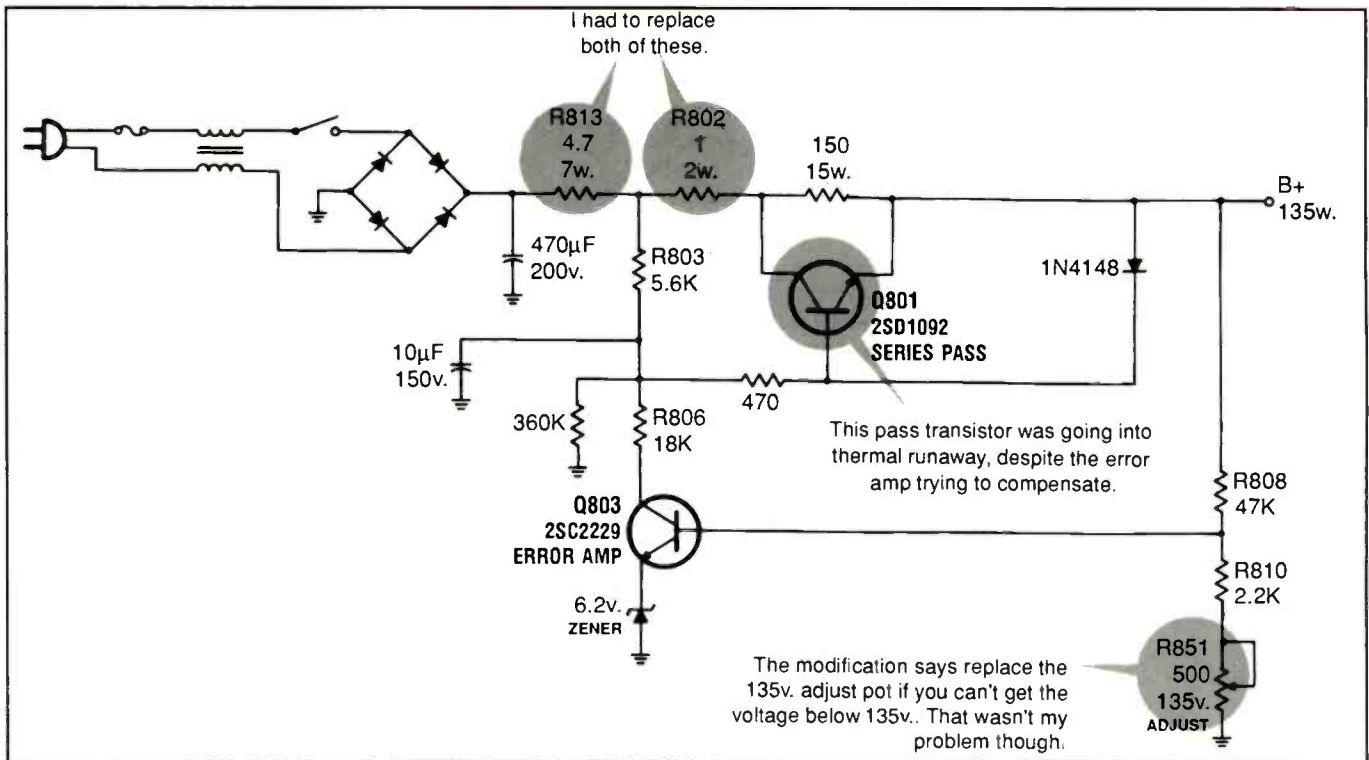

Figure 2. The 135V power supply and regulator circuit.

takes to make electronic servicing pay. Hopefully, you'll find it interesting from a technical perspective as well as from the perspective of what it took to get the job done—profitably or not.

I'm going to write this as if you're relatively new to servicing televisions. If you are, it should give you a kick-start into some typical problems. If you're an old hand—well, bear with me and remember, I'm an instructor at heart.

A color TV with no picture

The color television was a 20 inch Citizen JCTV3049X (about 5 years old). It came from a friend who said the picture had just disappeared one day. I immediately suspected that it was either a power supply problem or a bad horizontal output section (since the high voltage for the CRT and several other power supplies are derived from the horizontal flyback transformer).

Some basic checks

I started by plugging in the set and pushing in the power button. I know it seems obvious but, if you are just starting out, you might not be aware of how often a piece of equipment would work fine if the customer would just plug it in. Besides, you can often gain useful clues from simple tests.

In this case I heard a click from inside the set so I knew something was working. I assumed it was power relay. Newer sets with remotes have power on the infrared receiver circuit all the time so it can sense when the remote tells it to turn on. This picks up a relay which powers up the rest of the circuit.

So I had one piece of information: I knew the main fuse wasn't blown and some of the circuitry was working. At this point I didn't have a schematic but I figured I could check out the basics without one. I opened the set up and used my high voltage probe to check for high voltage stored in the picture tube, just to be sure. I didn't expect to find any, but it couldn't hurt and it's safer too. Then I went looking for the horizontal output transistor.

Checking the horizontal circuits

This set has an L-shaped heatsink attached to the main printed circuit board. Two power transistors in TO-3PJ packages were bolted to the heatsink. I checked both transistors in-circuit using the diode range on my trusty DMM. One of them showed a short across all three pins. The other checked out good. I heated up my soldering iron and removed the suspect transistor (a 2SD1426). Out of circuit it still checked bad. I figured I had hit the jackpot on my first try. (See Figure

1 for the schematic of the horizontal output section and flyback.)

Always check electrolytic capacitors

While I was looking around in the area I noticed a small electrolytic capacitor, a 470µF at 16V radial type, that was bulging a bit on top and it had a dark residue on it. These caps are built with seams or grooves in the surface of the metal can projecting out from the middle. They provide a spot where the cap can pop open if pressure builds up inside. This tends to release the pressure without exploding and spreading white fluff around the inside of the set. This cap looked like it might have gotten hot and popped, allowing the electrolyte to flow out.

I removed the capacitor from the board and checked it using my meter and a simple capacitor checker. Both tests showed okay. The ohmmeter test showed the resistance increasing as the cap charged up. The cap checker indicated about 520µF.

Still, I've found you can't always trust these readings with an electrolytic. They tend to break down at higher voltages than these testers put out. I took a small dental pick and poked at the seam on the top of cap where the bulge and residue was. The pick went right through and into the cap. At that point I was certain. I decided to replace it.

*When Your Reputation is at Stake...
Rely on Genuine*

JVC

**Parts &
Service Tools**



**Our High-Quality Drums
Are Built Entirely In-House**

**Comprehensive
Maintenance Kits**



**Troubleshooting On the
Spot and On the Mark**

JVC's leadership in video development enables us not only to manufacture superior VCR's and camcorders, but also to offer you a dependable supply of video service parts and tools. While low-cost imitation parts are readily available, using them will rapidly erode your customers' trust and ultimately cost you more in lost business and damaged credibility. Quality service means quality parts and regular maintenance. Drums, for example, should be replaced after 2000 hours of operation. Our upper drums are fully interchangeable with original JVC drums and assure absolutely no degradation in original JVC performance. And because we believe that superior service is the key to customer satisfaction, we offer complete maintenance kits that allow you to replace all parts at one time. We also provide a wide range of sophisticated service tools that make troubleshooting and maintenance easier, more accurate, and more efficient.

...From your Genuine JVC Authorized Distributor

Phone 800-289-0300 FAX 800-289-0301

ae andrews
electronics

P.O. Box 914, Santa Clarita, CA 91380-9014

Inquiries: 805-257-7700

FAX 805-295-5162

Circle (52) on Reply Card

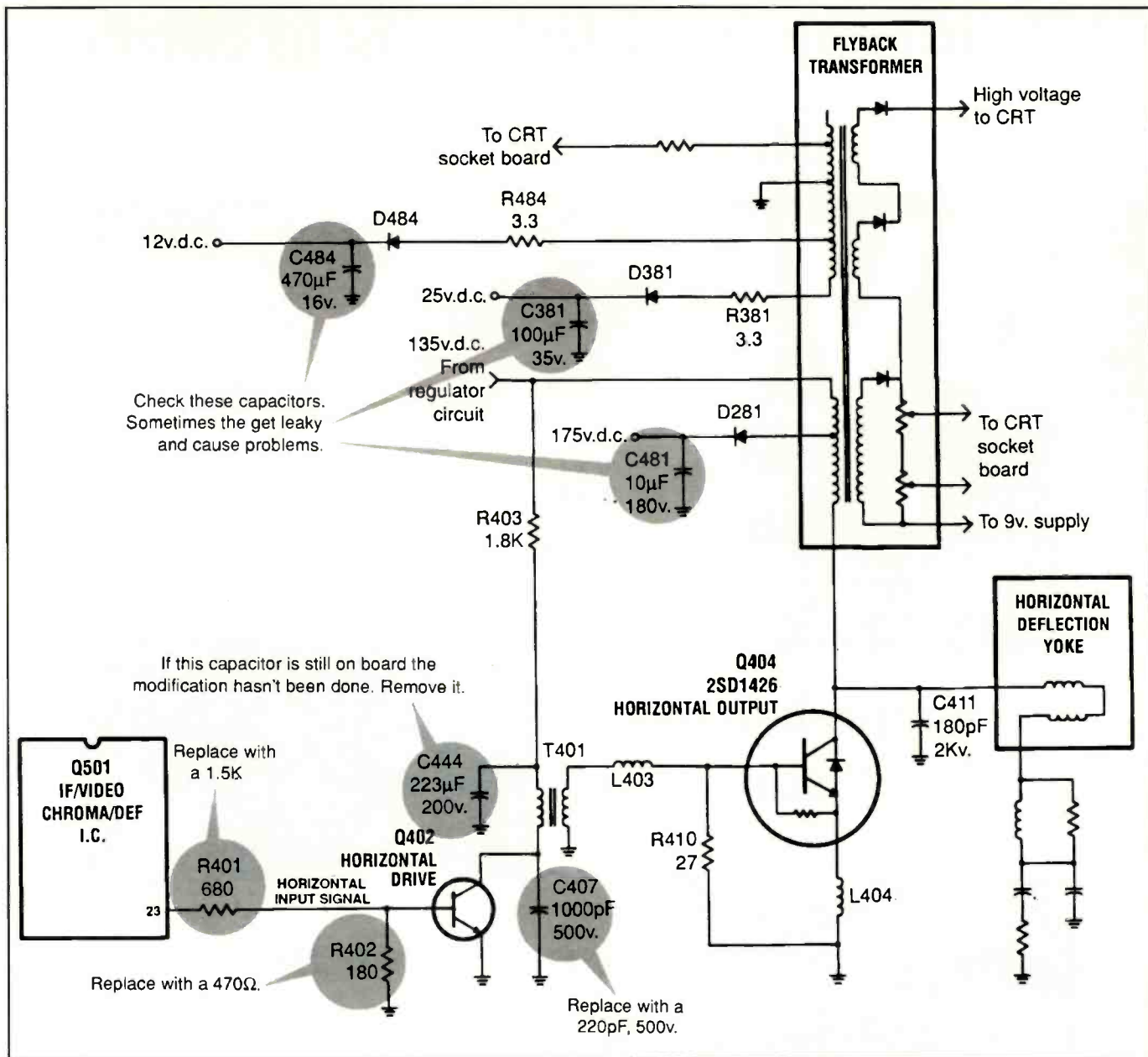

Figure 3. Citizen issued a modification for this set which fixed the overheating problem.

Obtaining service information and replacement components

Of course, when you don't do repairs everyday you never have the right part, so I had to run out and get both the transistor and capacitor (actually I have hundreds of left-over parts from my business days but are they ever the ones I need? Not often enough, anyway).

While I was out getting the new parts I also stopped by the local Citizen warranty service depot, Ambassador TV. The young lady there was nice enough to photocopy the main schematic for me and didn't even charge me for it. The next day I replaced the cap with an equivalent and the transistor with an ECG2302 replace-

ment part and then plugged the set in and switched it on.

The smoke test

Yes, I admit it. I just switched the set on. It wasn't that I didn't know enough to use a variable transformer to bring the power up slowly while watching the current draw. Mainly, it was just that I didn't have a variable transformer handy.

One of the last duties performed by my former employee from my servicing days was to burn out my variable transformer. No that didn't precipitate his dismissal, but it didn't keep him around any longer either. Ever since, I've been meaning to save up for another one (variable trans-

former, I mean, not another employee). I just haven't gotten around to it yet. Yes, I know it's lame, but that's my story and I'm sticking to it.

Luckily for me I didn't smoke that brand new replacement transistor, but the set still didn't work. No high voltage, no horizontal output waveform, nothing.

Checking the B+ supply

Now, using the schematic, I started looking for the B+ supply and found that it was only running at about 70V. From the schematic I knew that the B+ was supposed to be 135V. I traced the B+ rail back to the power supply and regulator circuit and started looking there (see Fig-

CITIZEN ELECTRONICS
ISSUED BY ENGINEERING DEPARTMENT
MODEL: JCTV 1544/3049X

SYMPTOM: HORIZONTAL DRIVE TRANSISTOR Q402 AND HORIZONTAL DRIVE TRANSFORMER T401 OVERHEAT

CAUSE: HORIZONTAL DRIVE CURRENT TOO HIGH COUNTER PLAN: 1. FIRST EXAMINE THE TV CHASSIS, IF THE CAPACITOR (C444) IS PRESENT, THIS MEANS THE TV CHASSIS IS ONE OF EARLY PRODUCTION WHICH NEED THE FOLLOWING MODIFICATIONS.

- A. REMOVE C444
- B. REPLACE C407, 1000PF WITH 220PF, 500V CAPACITOR
- C. REPLACE R402, 180Ω, WITH 470Ω RESISTOR
- D. REPLACE R401, 680Ω, WITH 1.5KΩ RESISTOR

2. IF THE TV CHASSIS SHOWS THAT THE C444 CAPACITOR IS MISSING, NO MODIFICATION IS REQUIRED. JUST REPLACE THE DEFECTIVE COMPONENTS FOUND. FOR EXAMPLE, Q402, T401, Q404 CHECK THE APPEARANCE (MELTED OR CRACKED OPEN CAPACITOR), SUCH AS C481, C381, ELECTROLYTIC CAPACITORS.

4. CHECK FOR COLD SOLDER JOINTS ON T461 (F.B.T.). FINALLY CHECK AND ADJUST THE 135V B+ WITH A DIGITAL VOLTMETER TO BE BETWEEN 134V AND 135V, MAKE SURE IT IS NOT OVER 135V. IF ADJUSTING R581 WILL NOT LOWER THE B+ TO BELOW 134V, IT IS NECESSARY TO REPLACE R581.

Figure 4. A copy of the manufacturer's modification specification.

ure 2 for the power supply and regulator).

I fully expected that the power supply series pass regulator transistor must be bad. Probably an open circuit, but I had already checked it out, at least in a cursory fashion. The regulator was the other transistor on the heatsink. I checked it again and then started doing voltage checks in the surrounding circuitry. I measured the voltage at the output of the bridge rectifier and found about 180V, just as it should have been. Measuring across R802, a 1Ω at 2W resistor, I found the missing 110V. Resistor R802 was open.

I dug around in the box where I keep 1Ω resistors, (and 2Ω, and 3Ω and 4Ω. In fact I keep all my higher wattage resistors in there ever since the cat knocked my resistor assortment box off the wall). After twenty minutes of searching I found one and soldered it into the board. Then I turned on the television. Again.

The set worked; for a while

Well, for a second time I was lucky. At least temporarily. This time the set came on. I heard the crackle of high voltage and the screen lit up. I connected the cable and checked the picture. Everything seemed to be fine. . . for a while.

At this point I made my second mistake. Since the set was actually working,

I didn't check the 135V supply right away. I fiddled with the controls, turned it on and off to see if it would degauss a spot in one corner of the screen, watched a bit of "Roseanne," etc.

The next thing I knew the screen blanked again, then came on, then went off again. I investigated the problem and found the 135V supply about 10V high and the heatsink was hot enough to fry eggs.

I started to make some measurements to isolate the problem but before I got very far the set quit again, this time for good. I don't know why we say "for good" because it wasn't.

Mulling the problem over

I started thinking about the problem, first of all wondering why the heatsink should be getting so hot. The power supply being 10V high wasn't good but I didn't think that would cause the kind of power dissipation I was seeing. It occurred to me that one of the filter caps in the secondary supplies powered from the flyback might be shorting out and drawing lots of current.

I checked all of these and was pretty sure they were good (but, again, this is one of the uncertainties of this kind of work. You always question whether the test you made really told you the whole

truth). Anyway, after checking everything in the area that I thought could cause the problem and finding nothing, I began to think the horizontal flyback transformer might have some shorted windings which could be the cause. I couldn't think of a reliable way of testing it to be sure so I decided to call up Ambassador TV and see what they thought. After all, they had probably seen lots of these sets.

Help from the manufacturer

It turned out my thinking was partially right. They had seen the problem before but they were sure it wasn't the transformer. When I called the shop I got one of the technicians on the line. Right away he told me there was a modification put out by the manufacturer. The original design left the set prone to drawing too much current by the horizontal output stage. The cure was to remove one capacitor, replace another, and also replace a couple of resistors in the output stage (see Figure. 3). He said he would fax me the modification notice.

About this time I began to wonder if this television was going to become a second career for me. A quick mental calculation reminded me that charging anything greater than two dollars an hour would put the cost of the repair into the ballpark of a new television set. I shifted gears and moved into "chalk this one up to experience" mode.

Two problems

As I checked out the circuit I found two problems. A 4.7Ω, 7W resistor, next to the 1Ω resistor I had replaced before, was open and the horizontal output transistor was shorted out; again (oh, why didn't I save up for that variable transformer?).

Again, I went searching for parts and had to run out to get some. I put in the transistor and resistor as well as the modifications called for in the manufacturer's specifications (Figure 4 shows the parts and modifications required). Finally, I got the set powered up again. This time I was a bit more careful and immediately checked the 135V power supply. It was low and I adjusted R851 for 134V, then sat back and watched.

Something was still wrong

Everything looked good for a few minutes. Then the voltage started to creep up. Within a couple of minutes it was over

ELECTRONIX

C O R P O R A T I O N

Technical Parts and Supplies
for the Service Industry

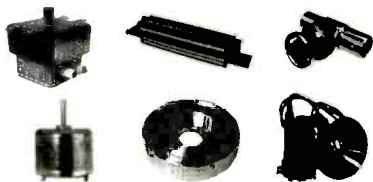

Quality Parts - LOW Prices



Free Catalog
(800) 223-3205

Electronix Corporation

313 W Main St Fairborn, OH 45324
Phone (513) 878-1828 Fax (513) 878-1972

Circle (57) on Reply Card

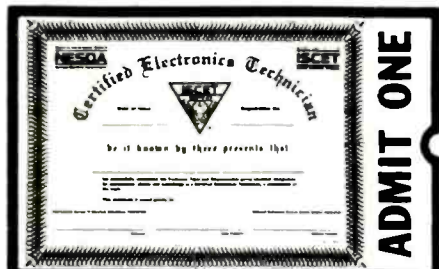

Your Ticket To SUCCESS

Over 28,000 technicians have gained admittance worldwide as certified professionals. Let your ticket start opening doors for you.

ISCET offers Journeyman certification in Consumer Electronics, Industrial, Medical, Communications, Radar, Computer and Video. For more information, contact the International Society of Certified Electronics Technicians, 2708 West Berry Street, Fort Worth, TX 76109; (817) 921-9101.

Name _____

Address _____

City _____

State _____ Zip _____

Send material about ISCET and becoming certified.

Send one "Study Guide for the Associate Level CET Test." Enclosed is \$10 (inc. postage).

140V and still climbing. I shut off the set, pulled out the rest of my gray hair chewed my nails, and stared at the schematic.

Understanding the operation of the power supply

I went back to the power supply circuit. This is a pretty standard regulator circuit using a zener reference and an NPN transistor (Q803) as an error amp. Resistor R851, the voltage adjust pot, is part of a voltage divider (R808, R810, R851) that samples the regulator output voltage, scales it, and presents it to the base of Q803. The zener diode holds the emitter of the transistor at 6.2V and the base at about 6.9V.

If the regulator output voltage increases it should increase the base current and turn the transistor on harder. This should "rob" base current from the pass transistor (Q801) pushing it toward cutoff. This should decrease the regulator output voltage; negative feedback.

I turned off the set and let it cool down for a while, then turned it on and monitored the 135V supply and the voltage at the collector of Q803. As the output voltage climbed, the collector of Q803 dropped, but this didn't seem to affect Q801. Eventually the collector of Q803 went to about 6.5V which indicated that it was saturated. It still didn't stop the 135V supply from climbing above 140V. I tried cooling various parts in the area and found that cooling the heatsink brought the voltage back down.

Why wasn't the negative feedback working?

What was happening? The negative feedback seemed to be there, it just wasn't working. I checked the values of all the resistors in the area. They were all good. I monitored the voltage between R803 and R806 but couldn't see any perceptible change in voltage as Q803 moved toward saturation. I did some quick calculations and decided I probably wouldn't be able to see any change there.

I found myself in that difficult situation where I'd checked everything, couldn't find an obvious problem, but the problem still existed. Frustrating. In the end I came to the conclusion that it had to be the pass transistor. Although it was working, it was temperature sensitive. I was familiar with thermal runaway having worked on lots of power amplifiers

but it seemed strange that the transistor could runaway when the negative feedback circuit was operating. The negative feedback circuit should have compensated and brought it back into balance.

What was it Sherlock Holmes said to Watson? "How often have I said to you that when you have eliminated the impossible, whatever remains, however improbable, must be the truth?" Maybe you've seen this kind of problem innumerable times before, but it was a new one to me. Nonetheless, again I went in search of parts, obtained a new 2SC1092 transistor and installed it.

Finally the problem is solved

Glory! The television set worked. I adjusted the power supply voltage and monitored it for several hours. It stayed within 2V of the 134V I set it at and the set worked beautifully.

Some conclusions

Well, what did I learn from this merry chase (besides the fact that I need a new variable transformer, I mean)? First, while I'm no Einstein, I think I can troubleshoot as well as the next guy. But there is really no way to know that this particular model of television requires a modification, unless you are a factory service center or have stumbled on it. To be successful and efficient you have to have some access to factory information.

Second, there are some things you probably haven't come across, even after you've done this kind of work for years. Just the same, nothing beats experience, and I'm sure there are lots of you out there who agree that it's more important to know what goes wrong with a specific set than to analyze and troubleshoot it laboriously time after time. That's how you make money, and that's why there are so many companies advertising databases of typical fixes in this magazine.

I think I learned something else, too. Those of us who teach the theory, and dabble in the practical, like to think we know what electronic servicing is all about. But it's you guys, out there making it pay everyday who deserve a real pat on the back for packing away the theory and all those little tidbits of information so you can use them to keep this stuff working. Keep up the good work, and oh, by the way; anybody out there have a used variable transformer they want to sell? ■

Developments in electronics technology are generally accompanied by developments in the test equipment needed to provide useful information to the technician who will service them. For example, in recent years, the development of the laser for use in such disparate products as the compact disc player and the laser printer have made the laser power meter a necessity for the technician.

As another example, the application of integrated circuits in so many consumer products, from TV sets and VCRs to personal computers has made necessary a host of test products, from small and inexpensive logic probes and pulsers, to highly sophisticated and expensive logic and state analyzers.

The old standbys stand by

But the introduction of newer test equipment for newer challenges in consumer electronics doesn't render the more familiar test equipment any less necessary. The oscilloscope and the DMM as well as other test instruments and accessories like the variable transformer, the isolation transformer and the bench power supply are just as necessary as they ever were to the serious consumer electronics servicing technician. In other words, the arsenal of test equipment required by the technician doesn't change, it simply grows.

Actually, that's probably not an entirely correct statement. A case could be made that the test equipment requirements of the typical consumer electronics technician not only grows, but changes as well.

For example, while today's technicians require oscilloscopes and DMMs and other old standbys just as much as they did 10 or 20 years ago, in many cases the test equipment they require has to be more sophisticated than it was before. In other words, because the products the technicians face are so much more sophisticated than they once were, the test equipment must also be more sophisticated.

The oscilloscope may need to have a wider bandwidth and more automated front panel features. The DMM may need more functions and greater accuracy.

Some things to consider

The value of a piece of test equipment to the technician then depends on

a number of factors. Here are a few:

- Ease of use
- Capability
- Accuracy
- Cost
- Support by the manufacturer
- Versatility

Guidance becomes more important

The more feature rich a product becomes, the more difficult it is to compare features and to know what product to buy. Anyone who has ever agonized over making a wise purchase in today's environment knows how true that is.

For example, trying to compare the features of modern appliances or cars to try to make an informed decision becomes ever more difficult. Each manufacturer has a range of products. Each level of the product within the range offers a set of features. But levels of product features differ from one manufacturer to another. Even when the features are more or less the same, one manufacturer may use a different term to call a feature, making the choice still more difficult.

This type of problem is less pronounced when it comes to test equipment, but it does exist. Choosing a piece of test equipment from among the various levels of features and prices from a variety of manufacturers is a challenge.

Fortunately, there are a number of resources that a consumer electronics technician can use that will help him choose from among the many test products offered by the many manufacturers.

For starters, there are the catalogs offered by the manufacturers themselves. Most of these provide details of the features offered by each of the products in that company's line. Not only that, but many of the manufacturers are a treasure trove of information on how to connect the equipment, and how best to use it to achieve accurate results.

Even better in some cases are the catalogs offered by distributors and by companies that rent or lease test equipment. Their listings list products offered by a number of manufacturers within each price level, and so, make comparison somewhat easier.

Buying a piece of test equipment

When a service center buys a piece of

test equipment, the purchase may not be completely thought through. For example, when it's decided that the service center needs a new oscilloscope, some research is performed on the products and prices, and an oscilloscope is purchased.

Most purchases done in this manner turn out fine, but sometimes the organization learns to its chagrin that the unit just doesn't have the required features to do the job. In other cases the organization learns too late that the unit they just bought is far more than they'll ever need, and the money tied up in it could be used elsewhere. You see some of those items listed in Readers' Exchange.

Just as with any purchase, the use to which the test equipment will be put should be thoroughly studied. The best approach would be to put together a checklist, and give every technician who is likely to use the unit an opportunity to participate in the decision. The following example checklist questions are for an oscilloscope, but a similar checklist would be useful for any other piece of test equipment.

The checklist

- What products will this equipment be used to test?
- What bandwidth is needed?
- Single-channel or two-channel?
- Is waveform storage needed?
- Will this be used at the bench only, or on site as well?
- Does this oscilloscope need an on-screen readout of waveform parameters?
- Can this purchase be cost justified as a time and effort saver?

Getting to know the suppliers

Because the decision to purchase a piece of test equipment is so important, the more you know about the manufacturers or suppliers, the better informed your decision will be.

This special advertising section, "Test Equipment Showcase," was conceived as a way to help bring more information about test equipment providers to readers. Every advertiser in this section has been given extra space to tell readers something about that company, or to help readers understand the value and use of that company's products. We invite you to read what these companies have to say about themselves and their products. ■

MCM Electronics
 650 Congress Park Drive
 Centerville, OH 45459
 Phone: 800-543-4330
 Fax: 513-434-6959

MCM is dedicated to delivering the finest test equipment values in the market today. Names like Fluke, Leader, Hitachi and B&K are recognized leaders in the consumer electronics service industry, and available from MCM.

TENMA Test Equipment
"Tested Accurate Proven Reliable"

One name that is rapidly emerging as the top choice among service technicians is TENMA Test Equipment. Every TENMA product is engineered to exacting industry standards required to meet the needs of today's professionals in service, research and development, testing and training. Regardless of the measurement or test application, TENMA delivers reliable performance, accuracy, functional design and dependability. Known throughout the indus-

try as "quality test equipment at an affordable price," TENMA provides unsurpassed value and quality on the entire line of test equipment including oscilloscopes, power supplies, sweep generators, audio/video test equipment, and a vast selection of handheld instruments including a full line of DMM's.

Discover The MCM
Electronics Difference

MCM publishes two full-sized catalogs annually. The latest issue boasts over 1,200 new products, and features over 30 pages devoted solely to test equipment. In addition, MCM stocks over 21,000 of the most commonly used repair parts, components, semiconductors and tools in the electronics industry. Sales flyers are mailed regularly featuring specially priced items and new product additions keeping the customers up-

to-date on the latest available products.

Superior Customer Service

The MCM staff is trained to answer all calls fast, friendly and efficiently. All sales representatives are professionals who are available on toll-free lines to provide immediate information on stock availability and pricing. They are available Monday through Friday 7:00 A.M. to 9:00 P.M. EST, and Saturday 9:00 A.M. to 6:00 P.M. EST. Faxed orders are also accepted 24 hours a day, seven days a week. MCM also provides highly trained electronics technicians to answer customers product questions. With a separate toll-free "Tech Line," customers receive prompt answers to their questions by calling 1-800-824-TECH (8324).

Fast Delivery From Two
Distribution Facilities

MCM is committed to providing superior customer service. Distribution centers are strategically located near Reno, NV and Dayton, OH. This enables fast delivery at ground rates throughout the US. In addition, with over 21,000 items stocked, 99% of all orders are shipped within 24 hours. For more information and a free catalog, call 1-800-543-4330, in Dayton, OH, call 513-434-0031.

TENMA™ TEST EQUIPMENT
NTSC Waveform Monitor/Vectorscope/Oscilloscope

The newly introduced NTSC Waveform Monitor/Vectorscope/Oscilloscope, provides a combination of three quality instruments for one low price. This is another reason why TENMA is the most talked about test equipment in the industry today. Known for its high quality and affordable price, TENMA has a full line of test equipment. All TENMA Test Equipment is manufactured to the exacting standards of today's professionals. The complete line of TENMA Test Equipment can be found at MCM Electronics. MCM stocks over 21,000 service parts, semiconductors, test equipment, and much more. Call for a FREE catalog today.

#72-6055
\$1999



Price effective until February 29, 1996



To order or get
 your free catalog,
 call . . .

1-800-543-4330

Please refer to code in lower right corner



MCM ELECTRONICS®
 650 CONGRESS PARK DR.
 CENTERVILLE, OH 45459-4072
 A PREMIER Company

Authorized Original Parts Distributor
Panasonic / Quasar / Technics

Get fast delivery from our distribution facilities near Dayton, OH and Reno, NV!

ES84

Sencore, Inc.
3200 Sencore Dr.
Sioux Falls, SD 57107
Phone: 605-339-0100
1-800-SENCORE (736-2673)
Fax: 1-605-339-0317

Real people answering your servicing needs!

Time is money. Lost or wasted time is money right out of your pocket. Every time you have to fiddle with a knob, connect and reconnect leads, or remeasure a test point because you just aren't sure, it costs you dearly.

Saving time is our business. Sencore test equipment is specially designed to help servicers save time. As you look at the Sencore product line, you'll notice that each instrument has a fresh, uncluttered, easy-to-use look. Our design engineers put the complicated electronics on the inside, but keep your operation simplified on the outside.

Each member of Sencore's exclusive instrument line is packed with time-saving, money-making features not available anywhere else. Sencore products are widely known for their quality, innovation, and outstanding value. And each instrument is all American-made, right here in the heartland of the U.S.A.

Plus, your investment in Sencore instruments is backed by the best support in the business. Starting with the Sencore News, you get informative articles and tips on how to use your equipment in modern circuits. You also get helpful Tech Tips, Tech Tapes, and field workshops guaranteeing you get the most from your investment. Our obligation and support is just beginning, instead of ending, when you say "yes" to Sencore test equipment.

Start the road to success right now. Call us toll-free at 1-800-SENCORE and we'll get your service center equipped to handle even the toughest troubleshooting challenges.

About Sencore . . .

Sencore was started in 1951, in downtown Chicago, Illinois by R.H. ("Herb") Bowden. As the business grew, Sencore moved west to Sioux Falls, South Dakota. The now second generation business remains in Sioux Falls where Sencore is proud to be actively involved in community events and charities.

Sencore designs and manufactures test instruments that provide the highest quality and reliability in the entire service industry. Every Sencore instrument is engineered to provide you with exclusive tests and capabilities that will make your troubleshooting easier and more efficient. When you invest in Sencore instruments, you also receive the best after-the-sale support available in the service industry.

During the past 40-plus years, Sencore has remained dedicated to one goal—mak-

ing you more successful in electronic servicing. And since our success depends on your success, we're working even harder to be your test equipment company.

Toll-free access to an entire company

Dial us now. One toll-free number, 1-800-SENCORE (736-2673), connects you to a factory full of "real" people (not a computer) dedicated to making you and your business more successful. We'll answer any questions you have concerning a new product, application of a Sencore instrument, ordering information, or technical service. We're waiting for your call!

One stop shop

We'd like you to make Sencore your "One Stop Shop" for all your test equipment needs. When you invest in Sencore equipment, you invest in an entire company devoted to saving you time and making your job easier. This dedication assures you of the best customer support in the industry from people who care.

Technical Sales Representatives: It all starts with answering your needs as a servicer. Our Technical Sales Representatives will listen to your needs, and work with you to come up with a solution. You'll be talking to a technically-trained person (not just an order taker) experienced with the operation and benefits of the entire Sencore instrument line. Your Technical Sales Representative will become your "friend at the factory" to assist you before, during, and after the sale.

Financing: We'll get you started with flexible investment terms to make your purchase easier, plus we can finance your investment at low rates with payments you can afford. Sencore's own financial division also serves as a highly reputable reference with other creditors.

Application Engineering: Once you've made your investment in Sencore test equipment, our job has just begun. If you need assistance using any of Sencore's instruments, our Application Engineers are just a toll-free phone call away. They're spe-

cially trained on the operation and uses of every item in the Sencore line. Our Application Engineers are dedicated to customers and helping solve problems—both before and after the sale.

Service: If your instrument should ever need service or recalibration, Sencore also services what we sell. Our factory service center backs your purchase with quality service that brings your instrument back to the same (or better) specifications as when new. Our top notch Service Department backs your equipment with three-day service, instrument loaners, and toll-free access for help servicing your own Sencore instruments if you choose.

Parts: Genuine original parts ensure your equipment is safe, accurate, and reliable. Our parts department ships orders within 48 hours guaranteeing maximum up-time and productivity from your Sencore test equipment.

Product Delivery: Most Sencore products are in stock and are shipped within 48 hours of receipt of your order—guaranteeing you maximum productivity right from the start. Overnight delivery is available for more immediate needs.

Buyer protection

30-Day Money Back Guarantee: Sencore's no-nonsense 30-day money-back guarantee assures you that you've made the right choice. Every Sencore instrument and accessory is covered by this guarantee of satisfaction. Simply stated:

"If you are not completely satisfied with any Sencore instrument, you may return it during the first 30 days and we'll give you a full refund, including freight, no questions asked."

You're always sure you've made the right decision when you say "yes" to a Sencore investment.

Product Warranty: Every Sencore instrument is warranted for one year against defects of any cause except acts of God and abusive use. During this warranty period, Sencore will correct any covered defect without charge for parts, labor, or recalibration.

Made Right Guarantee: We guarantee your Sencore instrument was "Made Right" or we will make it right without charge for parts and labor for as long as you own the instrument. This lifetime guarantee covers any defects caused by faulty design or workmanship errors. All parts and labor necessary to correct a workmanship defect covered by this guarantee will be at no charge to you. There will be a recalibration and handling charge if the instrument is no longer covered by Sencore's one year warranty.

Easy Ordering—Three Ways To Contact Us

Phone (Toll-Free)
 1-800-SENCORE
 (736-2673)

Fax
 1-605-339-0317

Mail
 Sencore, Inc.
 3200 Sencore Dr.
 Sioux Falls, SD 57107
 (605)339-0100
 Call 1-800-SENCORE (736-2673)

Herman Electronics

7350 N.W. 35th Terrace
Miami, FL 33122
Phone: 800-938-4376
Fax: 800-938-4377

Herman Electronics is one of the country's largest original replacement parts distributors and is NOW a major supplier of Test Equipment, Tools, Soldering Equipment and everything in electronic service accessories. In business for over 40 years, Herman Electronics has clearly established itself as an industry leader by providing quality products and superb customer service to all facets of the electronics industry.

If you need test equipment, Herman has it! Herman Electronics is your source for FLUKE, B&K, WAVETEK, LEADER, AMPROBE, GOLDSTAR, HITACHI and SIMPSON as well as probes and accessories. The company is quickly earning the reputation as stocking one of the largest and most diverse inventories of tools, test equipment and soldering equipment in the country. It has always been the Company's philosophy that in order to maximize customer service, the item must be on the shelf when needed in order to facilitate immediate delivery - and Herman does just that!

Herman Electronics' new focus is to

become a SINGLE SOURCE to all facets of the electronic service industry. As one of the nation's largest factory authorized OEM parts distributors for SONY, PANASONIC, RCA, TOSHIBA, SAMSUNG, QUASAR and KENWOOD, there is no longer the need for busy service organizations to search multiple vendors for parts and related service accessories such as tools, soldering equipment, chemicals, test equipment, etc. says Jeffrey A. Wolf, Vice President and son of the company's founder. "It is our goal to be a SINGLE-SOURCE to fill all of our customer's needs."

In order to accommodate this extensive expansion and significantly increased inventory, Herman Electronics recently relocated to a new state-of-the-art distribution facility. This facility will allow them to grow and prosper well into the 21st century.

Also, just arrived is the new HERMAN CATALOG. This 350 page buyers guide has everything in electronics including original replacement parts, accessories, tools, test equipment, chemicals, broadcast supplies

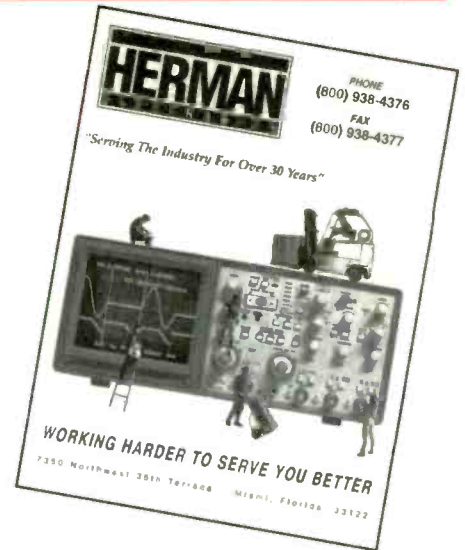

and everything in servicing products and accessories. Call today for your free copy.

Herman Electronics makes ordering easy. Customer service representatives are standing by to take your call. Call or fax us today toll-free. If you have any questions or you're not sure as to what you need, please ask to speak to an industrial sales representative for assistance.

If you have not given Herman Electronics a try, please do so today. Quality, Reliability and Service Excellence is what they stand for. Put the HERMAN TEAM to work for you!



IF YOU NEED IT... WE HAVE IT!

GoldStar SPECIALS

DMM - 3 3/4 Digit - 3200 Count Auto Ranging
Order # GOLDM333
\$49⁰⁰



100 mhz Scope
2 Channel Dual Trace
Order # GOLOS9100P
\$895⁰⁰

DC Power Supply
5 Amp
Order # GOLGP305
\$295⁰⁰

Weller SOLDERING SPECIALS!

40 Watt Temp Control Solder Station
Order #WELWLC100
\$34⁹⁵

WP25 Professional Soldering Iron
Order #WELWP25
\$24⁹⁵



HAKKO DESOLDERING TOOL

Portable desoldering tool w/built in vacuum pump
\$299⁰⁰



YOUR TEST EQUIPMENT SOURCE FOR:

▲ AMPROBE BK PRECISION GoldStar Xcelite
HITACHI ITT Pomona LEADER Simpson
WAVETEK KENWOOD FLUKE Weller

Call Today for your FREE HERMAN Catalog!

prices valid through Dec. 31, 1995

PHONE: (800) 938-4376
FAX: (800) 938-4377
7350 N.W. 35th Terrace • Miami, FL 33122

Fluke Corporation
P.O. Box 9090
Everett, WA 98206
Phone: 1-800-44-FLUKE;
Fax: 206-356-5962

"Our customers have the right to get a little more than they thought they paid for," says John M. Fluke, Sr., the Founder of Fluke Corporation.

Fluke's mission is to be the world leader in compact, professional electronic test tools. For many customers, that means turning to Fluke for the world's highest quality handheld digital multimeters and accessories. For others, it means harnessing the power of a digital storage oscilloscope by using Fluke's revolutionary ScopeMeter test tool. And for others still, it means discovering new products and new areas of Fluke expertise, such as wireless data logging and LAN troubleshooting.

Regardless of the specific product and application involved, Fluke encourages its customers to look beyond basic specifications, and look at the total combination of features, functions and overall value represented by a product's design and care taken in its production. This concept is engineered into every Fluke product, and is best exemplified by looking at our handheld DMM family.

Proprietary circuit design and manufacturing facilities
 Innovative instruments result when

engineers design products to solve specific problems, using state-of-the-art design and manufacturing resources.

Integrated circuits developed in our Microcircuits laboratory have produced breakthrough performance features for handheld DMMs, such as dB, capacitance, frequency and duty cycle measurement, virtually invisible autoranging, a fast analog bar graph, and a Touch Hold function.

Human engineered with attention to detail

You may never notice the finer details built into our multimeters, but each has been thoughtfully created for your benefit. Like non-skid rubber feet, grooved sides and textured cases for surer grip, and careful attention to color selection to match the job.

No other DMM manufacturer we know of invests as much care in human engineering.

Environmentally tested for reliability

Reliability, especially under tough conditions, is more important than ever today. So, by the time Fluke DMMs are ready to be tossed in tool cases, they've undergone a rigorous testing and evaluation program.

Fluke DMMs are regarded by industry professionals as the toughest, most forgiving multimeters ever made.

Accessories for every purpose

A full-line of accessories extend the measurement capabilities of Fluke DMMs. This includes temperature probes that convert any DMM into a thermometer (thermocouple, semiconductor and infrared types are available), current clamps, high-voltage probes, high-frequency probes, test leads and carrying cases.

American quality recognized worldwide

Design innovations and production efficiencies are essential to our commitment to manufacture the world's most capable multimeters . . . in the U.S.A. Fluke uses a variety of automated manufacturing processes, allowing us to offer you one of the highest quality multimeters available, at affordable prices, and backed by the finest warranty coverage in the business.

The Fluke multimeter. It's a product with a reputation to uphold. Built to meet your needs, and consistently exceed your expectations. An electronic tool you'll rely on for accurate measurements year after year.

For more information

For more information on Fluke multimeters, or any of our other professional test tools, call 1-800-44-FLUKE. Or write to: Fluke Corporation, P.O. Box 9090, Everett, WA 98206

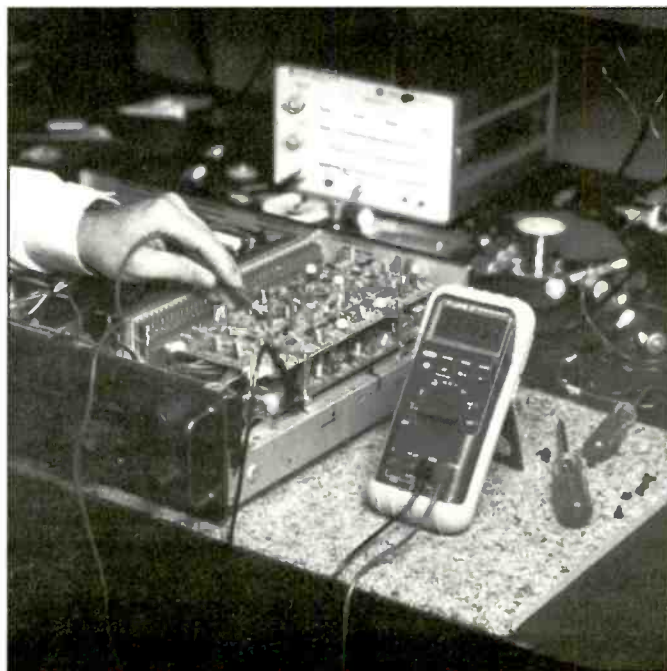

LG Precision
 13013 East 166th St.
 Cerritos, CA 90703-6227
 Phone: 310-404-0101
 Fax: 310-921-6227

LG Precision, internationally renowned for its electronic and electrical test products, was founded in Korea in 1976. Since its establishment, LG Precision has made significant progress in the field of test and

measurement instrumentation. In 1988, Mr. Phil Yoon transferred from Korea to the US and established the marketing and sales of analog and digital storage oscilloscopes, electronic frequency and universal counters, function generators, and multi-function digital multimeters for LG Precision. All of LG Precision's products undergo stringent quality control procedures.

LG Precision can measure its growth and success by the large investment of year end profits that goes directly into their research and development laboratory. Their attention to producing the best product at a cost effective price has given LG Precision a steady growth rate since its inception, with their sales doubling in the last 3 years.

Products in the Marketplace

The OS-3000 series of digital storage oscilloscopes are compact, lightweight and are designed to meet with IEC-348 safety requirements.

The OS-9020G, the most successful model of their multi-purpose oscilloscope line, is equipped to measure waveforms, and generates a triangle wave, sine wave and square wave.

Real time oscilloscope models 9020A, 9040D, 9060D, 8100A are designed with frequency bandwidth from 20 MHz to 100 MHz at a lower cost, but with the same high quality and performance while also meeting with the IEC-348 safety requirements.

Models OS-9020P and OS-9100P are newly designed real time, low cost and have just been released into the market. Models 902RB, and 904RD are multi-functional cursor readout oscilloscopes.

LG Precision offers a quality line of multi-functional digital multimeters that are listed in our advertisement, along with list prices. As you can see, we offer these DMMs with big features for a small price.

To find out more about our fine products mentioned above as well as our frequency counters, universal counters, and sweep function generators, technical data sheets are available from LG Precision directly or from our many distributors. ■

**WAVE
 GOODBYE
 TO PRICEY
 TEST EQUIPMENT**

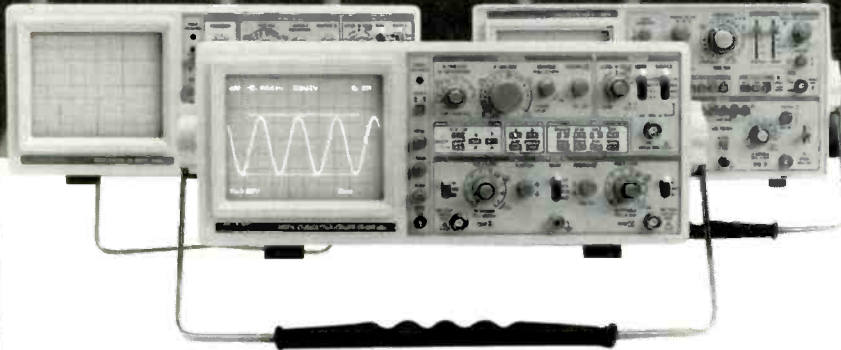

GoldStar offers a comprehensive line of affordable Analog and Digital Storage Oscilloscopes for your diagnostic needs.

Digital Storage with CRT Readout and Cursor Control	Analog CRT Readout and Cursor Control	Analog
OS-3020: 20 MHz, 20 MS/s OS-3040: 40 MHz, 20 MS/s OS-3060: 60 MHz, 20 MS/s	OS-902RB: 20 MHz, Delayed Sweep OS-904RD: 40 MHz, Delayed Sweep	*OS-9020A: 20MHz, Basic OS-9040D: 40MHz, Delayed Sweep OS-9060D: 60MHz, Delayed Sweep OS-8100A: 100MHz, Delayed Sweep OS-9020G: 20MHz with 1MHz Function Generator



LG Precision
The Sensible Source

13013 East 166th St., Cerritos, CA 90703-2226 310-404-0101 fax: 310-921-6227

Circle (62) on Reply Card

Wavetek

9145 Balboa Avenue
San Diego, CA 92123

Phone: 800-854-2708; 619-279-2200

Wavetek Corporation designs, manufactures and markets worldwide a broad range of electronic test and measurement instruments that are used for the design, service, evaluation, production and maintenance of electronic devices and systems. Wavetek has three operating divisions: Calibration, Communications and Instruments.

As part of the Instruments division, Wavetek's Test Tools product line has an enviable reputation for quality and reliability. This comprehensive line offers meter selections to fit a wide range of applications and features for all job requirements.

Four new additions (DM30XL, DM35XL, DM16XL and CR50) to Wavetek's compact XL series of DMMs offer even more choice and flexibility. These new multimeters expand Wavetek's already-existing proven XL family (DM5XL, DM10XL and DM15XL). The XL Series are compact, reliable, rugged and low cost DMMs. They feature large LCD digits for easy viewing, input warning beepers and safety test leads to safely meet measurement requirements of the field service industry.

Two new autoranging meters, models DM30XL and DM35XL, offer enhanced features such as a 3200 count display with bargraph, Data Hold, Auto-Off feature, a diode tester and continuity beeper. The DM30XL and DM35XL meters measure resistance to 30M Ω and ac/dc voltage to 600V, with the DM35XL adding capacitance measurement.

The model DM16XL is a DMM plus component test meter. The DM16XL is a full function DMM, and it measures frequencies, capacitance, transistor gain, logic and resistance to 20M Ω . The DM16XL also has diode test and continuity checker capabilities.

Unique among these new XL testers is the CR50, a capacitance/resistance meter with dual zero adjust. The CR50 features seven resistance ranges, 20 Ω to 20M Ω with a 0.01 Ω resolution, and nine capacitance ranges, 200pF to 20mF with 0.1pF resolution, making the CR50 a full capacitance meter.

In addition to these new XL meters, Wavetek recently announced the FPC850KIT, a new fiber optic power loss measurement converter. This new addition to its product line demonstrates Wavetek's constant striving to satisfy the ever-changing and increased needs of its customers. The new FPC850KIT, combined with a Wavetek or any other brand of DMM

with a dc millivolt range, is the low cost test tool for easily and conveniently qualifying fiber optic connections and cables. The power meter module's output has standard banana-jack style connectors which directly plug into the DMM's jacks. The FPC850KIT is coded for correct polarity and outputs millivolts directly proportional to dBm, with output 1mV per 1dBm.

The XT series are full function, digital multimeters measuring not only voltage, current and resistance, but also offer component testing capabilities, and functions important to troubleshoot even the most complex electronics. The most versatile of the line, the DM27XT, measures inductance from 2mH to 20H, frequency up to 20 MHz, and capacitance. The model DM28XT adds a temperature meter capable of addressing the demanding service needs of HVACR building maintenance technicians.

The Series 2000 provides engineers and technicians with the highest performance in professional-grade handheld digital multimeters. The series offers a variety of standard DMM functions in addition to a frequency counter, capacitance meter and an intermittent and pulse detector. The extra large, 4-digit LCD is backlit with fiber optics in models 2020 and 2030. Model 2030 offers 0.1% accuracy, capacitance range from 100pF to 2000 μ F, a frequency counter range to 2MHz, and true RMS measurement. The 2030 offers the most troubleshooting features available in a handheld DMM.

The CPM series are clamp-on, true RMS power analysis meters that combine many electrical meters into one, easy-to-use handheld instrument. It is optimal for electrical technicians installing, maintaining and monitoring electrical systems with linear and nonlinear loads.

Wavetek's CDM600 is a digital multi-clamp for ac and dc current. Using advanced Hall effect technology, it accurately measures ac and dc current up to 600 Amps without disturbing the electrical wiring.

Beyond handheld DMMs, a broad line of additional instruments are offered for the professional service technician. Included are bench-mount meters, portable function generators and frequency counters. For component test and troubleshooting, LCR meters, capacitance meters and logic probes are also available.

Wavetek's TC253 is a temperature converter which allows any brand of multi-

meter to read temperatures from -50°C to 900°C (-32.4°F to 1652°F). A variety of measurement probes are available for this model including immersion, surface, air/gas, piercing tip and more.

Wavetek also offers current clamps, ac/dc, and high-voltage and radio frequency probes for use with multimeters. The newest ac/dc current probes (CT235, 238 and CT237) provide a scaled voltage output and may be used with a variety of measurement instruments including, analog or digital multimeters, dataloggers, and chart recorders.

An extensive selection of replacement and application-enhancing test leads are available for various requirements. These leads are high-quality and can be used with any brand of meter. The lead tips are shrouded to protect the user from the dangers of exposed metal during testing. The silicon-insulated lead wires offer increased flexibility and high resistance to solder burns for the best performance and long life.

To ensure that the equipment performs to specification over the life of the product, Wavetek offers the customer a variety of services. All Wavetek instruments are warranted against defects in workmanship and materials. Wavetek's new "No hassle" warranty service is an industry first! Any defective meter will be replaced by your local dealer on-the-spot. Product support is provided on all products by Wavetek's highly qualified team of customer support technicians. For customers requiring calibration certifications, such as ISO9002 or military standard programs, Wavetek offers selection from basic certification to full NIST traceability.

In addition to the Test Tools product line, the Instruments division offers a full line of calibration products, test simulators, LAN cable and General Purpose test equipment. Wavetek's calibration and test simulation instruments are widely used in research and manufacturing environments. A large variety of precision voltage references, meter calibrators, arbitrary waveform generators and function and pulse generators are available to choose from.

For over thirty years Wavetek has provided high-quality products and service to our customers. Wavetek has a strong commitment to customer satisfaction, worldwide support and experienced technical support. Dedication to understanding customers' needs in an industry of constant technological advancements, keeps Wavetek in the forefront of product development and innovation.

With headquarters in San Diego, California, Wavetek sells its products through a worldwide network of representatives, distributors and dealers. For the name of your Test Tools dealer nearest you, call (800) 854-2708. ■

RNJ Electronics, Inc.

805 Albany, Ave., PO Box 528
Lindenhurst, NY 11757
Phone: 800-645-5833
Fax: 800-RNJ-FAX1

RNJ Electronics, Inc. is now entering its 15th year as a full-line discount distributor, servicing the TV, VCR, computer, stereo, and microwave repair industries. In addition, RNJ Electronics is a leading supplier of background sound products including PA amplifiers, microphones, speakers, wire, etc. The company has also become a leading distributor in an industry experiencing tremendous growth: the security industry, stocking products such as cameras, monitors, sequential switchers, quad splitters, lenses, etc.

The company publishes a semi-annual, 136-page catalog containing thousands of items all at discounted prices. Product categories in our catalog include test equipment by B&K Precision, EMCO, Vector, American Reliance, Global Specialties, Fluke, Wavetek, and AVCOM. In addition, the company also



stocks a full line of audio video and antenna accessories, universal remotes, TV and VCR wall mounts, mobile carts, service chemicals, an extensive line of VCR parts, camcorder accessories, TV and monitor flybacks, Japanese semiconductors, microwave oven parts, educational kits, tools and soldering equipment and computer accessories.

RNJ Electronics prides itself on its ability to stay current with the ever changing needs of its customers. Customer service is a top priority for the company. All orders are processed in a timely manner shipping via UPS. The company has added additional phone lines as well as an 800 fax line.

The company offers volume discounts for large orders. It also ships all over the world. RNJ Electronics, Inc. can meet all of your needs. Call toll free and see. ■

YOUR DISCOUNT SOURCE FOR:

TEST EQUIPMENT

AUDIO/VIDEO ACCESSORIES
VCR PARTS & ACCESSORIES
CAMCORDER BATTERIES & ACCESSORIES
CABLE TV CONVERTERS
VIDEO HEADS
TV & VCR MOUNTS
MOBILE SERVICE TABLES
TV PARTS & ACCESSORIES

SERVICE CHEMICALS

EDUCATIONAL KITS
TOOLS & SOLDERING EQUIPMENT
SECURITY EQUIPMENT
PA EQUIPMENT
INTERCOM SYSTEMS
SPEAKERS
A/V PRODUCTS
COMPUTER ACCESSORIES
FLYBACKS



SUPER SPECIAL



B&K MODEL 2120-
20Mhz OSCILLOSCOPE

CALL FOR
DISCOUNTED PRICE



ELECTRONICS, INC.

516-226-2700 • 800-645-5833
FAX-1-800-RNJ-FAX1



OUR
15th
YEAR

805 ALBANY AVENUE • PO BOX 528
LINDENHURST, NEW YORK 11757-0528

Specialized Products Company

3131 Premier Drive

Irving, TX 75063

1-800-866-5353

Fax: 1-800-234-8286 (24 hr)



Specialized Products Company is one of the leading suppliers of specialized tool kits and test equipment in the world. It has been a top 10 distributor for virtually every test equipment line it has offered. Today its inventory of over 5,000 specialized products includes 1,000 pieces of high-quality test equipment. As it celebrates its 30th anniversary, SPC continues to expand its product selection and prosper through a commitment to superior service to its specialized customers.

Founded in 1965 in Dallas, Texas, SPC sells almost exclusively in the service arena. From basic cable installation to board level component repair, SPC offers a wide range of products to accommodate virtually any service-related requirement. Service today runs the entire gamut of PC repair, LAN management, satellite communications, desktop video and everything in between.

In 1994, SPC sold products to over 35,000 different customers. A typical customer today is anything but typical. The past ten years have seen the emergence of self-maintainer customers and in-house service groups. On any given day SPC sells to banks, insurance companies, RBOCs, fast food restaurants, hospitals, airlines, etc.

SPC mails over a million catalogs a year. They are recognized and accepted within the industry as the standard by which all competitive publications are measured. Since these catalogs are produced in-house, it allows for both cost effectiveness and high response to changes in products and price.

Specialized Products Company is dedicated to offering the fastest turnaround in the industry. 98% of all orders are shipped the same day they are received (typically for overnight delivery). SPC utilizes three order centers (Dallas, TX; Nashua, NH; and Anaheim, CA) for inbound calls. Toll-free phone and FAX numbers simplify and speed up the ordering process. The toll-free technical support line currently handles about 50 calls each day. Its commitment to selling quality products and providing speedy service has earned SPC numerous awards for quality from such customers as Texas

Instruments, MCI, Abbott Laboratories and Loral Aerospace. As it enters its fourth decade in business, SPC continues to strive for a level of service unmatched in

the industry.

For more information, or to request a free SPC catalog, call 1-800-866-5353 today. ■



- Hand-held model tests 16-MB module in less than a minute
- Ability to modify RAS/CAS timings
- Complete DRAM SRAM testing

\$1694 ea.

IT SERVES YOUR MEMORY WELL.

The Sigma LC 32-Bit RISC Memory Test System.

Easy to operate, affordable to own.

You can pay a small fortune and get just the features you need in a memory tester. Or you can buy the Sigma LC and enjoy user-friendly reliability and power for thousands less.

Feature for feature, the Sigma LC compares with testers costing far more. Yet it doesn't let price compromise its performance. It provides the most complete set of in-depth functional testing available to determine good or bad memory.

As memory size increases, the Sigma LC keeps up, testing 100% of your memory at a record rate of 4 seconds per megabyte!

The Sigma LC also offers voltage flexibility, supporting modules with power between 3 and 6 volts.

The Sigma LC. The best tester in memory.

For more information on the Sigma LC or to place your order, call (800) 439-4250 or Fax (800) 234-8286

SPECIALIZED PRODUCTS COMPANY

©1995 Specialized Products Company

TENDEL Corp.
 4475 Golden Foothill Pkwy.
 El Dorado Hills, CA 95762
 Phone: 800-538-6894
 Fax: 916-939-4114
 Int'l: 916-939-4005

More than 9 out of 10 VCR problems are due to mechanical malfunctions!

A VCR contains rubber belts, idlers, gears, brakes, clutches, and tension bands designed to maintain torques and tensions during the various modes; (loading, play, rewind, fast forward, and stop). All are subject to wear.

Each time a tape is played, these components stretch, wear, shift position, and are stressed. Contaminants and even oxygen cause many of these parts to age and break down even without wear.

By the time a VCR requires service, several of these components are often out of tolerance. It's recommended to perform a thorough check of the other mechanical components to determine their operating condition too.

If you merely correct the immediate problem and return the VCR to the customer without a thorough check, there's a high risk that one or more mechanical components will soon either fail or cause erratic operation. The result is a disgruntled and possibly lost customer, and either a callback that wastes time or, the customer just tosses the VCR in his closet and purchases a new one, carefully selecting a different VCR manufacturer (and servicer). It's the same for cars, if you get a "lemon" and the dealer can't fix it properly, the customer will typically change to a different brand.

Every VCR servicer should include a check, and adjustment if necessary, of tape guide heights, holdback tape tension, and numerous torques (including

FF, REW, brakes and restoring torques). Each of these checks and adjustments is specified in the service manual for each transport. It is also valuable to check video head wear to see how many more hours of life the VCR owner can expect.

A thorough test and adjustment will allow service centers to do it 'right the first time', and possibly charge a little more money for performing all the tests that should be done anyway. You'll feel more confident with repairs, stop disappointing customers and avoid those dreaded callbacks.

Obtaining proper test equipment will save time in servicing VCRs, allowing higher quality repairs, and avoiding the high cost of callbacks. This provides the best VCR repair value for your hard earned test equipment dollar. ■

IMAGINE THE BEST VCR TEST INSTRUMENTS!

These are EVEN BETTER!

These VCR test instruments will actually help your business, by allowing **BETTER** and **FASTER** VCR repairs.

It's interesting how veterans of *trial and error* VCR repair, *suddenly* become our **BEST** supporters.

Try these gauges in your own shop, with a 100% satisfaction **money back guarantee**. STOP guessing and wasting valuable service time by continuing TRIAL and ERROR VCR repairs. The **RIGHT** tools make any job easier to do; these **ARE** the **RIGHT** tools for VCR repair!

EVERY VCR service manual shows a method of performing critical mechanical tests which cause the majority of VCR problems. **TENDEL offers the ONLY Universal** gauges for tape tension, guide heights, torques, video head wear, reel table heights, and **MORE**.



 **TENDEL**® 4475 GOLDEN FOOTHILL PKWY.
 EL DORADO HILLS, CA 95762

800-538-6894 / 916-939-4005

24 hour FAX line: (916) 939-4114

Circle (70) on Reply Card

★ ★ ★ TEST EQUIPMENT SHOWCASE ★ ★ ★

ITT Pomona Electronics

Providing Unique Accessories for Test & Measurement

1500 East Ninth Street

Pomona, CA 91766-3835

Phone: 1-800-241-2060, 909-469-2900

Fax: 909-629-3317

The Company

ITT Pomona Electronics is a leading supplier of electronics test accessories. The company's products are recognized worldwide as being of the highest quality, dependability and reliability. Additionally, Pomona's products, designed for a wide range of test and design applications, are immediately available from stock.

What is now ITT Pomona Electronics began as a radio and television repair service, started by two civilian-soldiers returning home from World War II. To do their jobs more efficiently, they began to develop their own accessories. The first actual product, a tube adapter, was offered in the early 1950's. Within a fairly short time a family of easy-to-use accessories emerged to answer testing problems. From the beginning, quality was as important as functionality.

Since then, rapid technological advances in electronics have created new testing challenges. ITT Pomona has responded to these advances by developing innovative test accessories and by expanding its distribution network to a global scope. Becoming part of ITT added financial strength and international access. Through periods of very accelerated growth, Pomona has continued to maintain its high standards of quality and market responsiveness.

Today Pomona has the broadest product line of test accessories in the world, for applications ranging from test labs to field service and plant maintenance. Its focus remains the same as during the company's founding: to contribute directly to the efficiency and productivity of electronics testing by providing quality test accessories second to none. Pomona's products are recommended by leading manufacturers of test equipment and instrumentation such as Fluke, Hewlett-Packard and Tektronix. They're uniquely designed to make using the instruments easy, productive and reliable, wherever they are used.

Its Products

Pomona offers literally thousands of

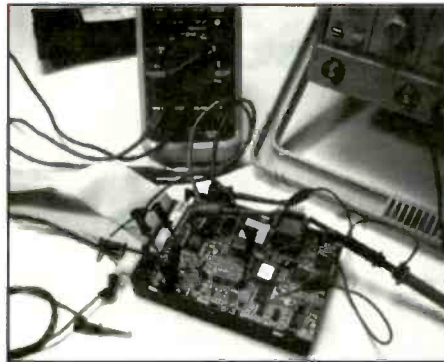

products, providing immediate, cost-effective solutions for specialized applications.

For 1996 Pomona will introduce an all new line of Test Companion™ test kits designed specifically to hold and protect Fluke, Hewlett Packard or Tektronix meters. These kits will include test leads, probes, grabbers and clips, organized in lightweight, durable Cordura carrying cases for use in the lab or in the field, providing an all-in-one portable "work center."

For surface-mounted devices, Pomona's family of IC test clips and new solder-on adapters provide a convenient test interface for fast, reliable circuit design and testing. Clips for 2- and 4-sided devices include those compatible with popular Intel and Motorola devices.

Pomona also offers interchangeable test leads, oscilloscope probe kits, IEC 1010-safe probe sets and accessories, high-voltage probes and individual DMM accessories and kits to expand DMM capability.

Pomona's Micrograbber®, Minigrabber® and SMD Grabber® and Ultra-Thin Grabber® test clips are recognized worldwide for precision, quality and reliability.

ITT Pomona Electronics prides itself in its on-site ability to produce quality product in volume quantities for the industry's most popularly based design and test needs. Contact: 1-800-241-2060, fax: 909-629-3317 for more information. ■

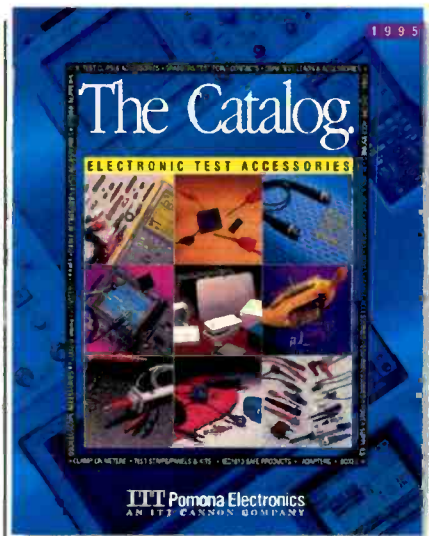

Brighten Up Your Test Life.

Using test instruments? Nothing will brighten your day more than one of these test accessories from the all-new Pomona Catalog:

- 30-450MHz monolithic Micro LC™ oscilloscope probes
- IC test clips for MC68360 and X86 devices
- Programmable DIP IC test adapter
- ESD service kits
- DMM test lead kits

You can put a FREE copy on your shelf today. Just visit your Pomona Distributor or contact:

ITT Pomona Electronics.
1500 E. Ninth St.,
Pomona, CA 91766-3835.
Phone: (909) 469-2900.
FAX (909) 629-3317.



ITT Pomona Electronics
AN ITT CANNON COMPANY

B&K Precision
 6470 West Cortland Street
 Chicago, IL 60635
 Phone: 800-462-9832
 Fax: 312-794-9740

For 41 years, B&K Precision has built upon its reputation for practical, durable, quality test instruments that offer solid price value. Many B&K Precision instruments have been in continuous use for

over 20 years. Another long-standing tradition is instrument repair and recalibration services and replacement parts availability throughout the product life.

B&K Precision now offers the nation's broadest line of electronic test instruments sold through electronic distributors. Over 400 distributors carry the B&K Precision product line. General purpose test instruments such as oscilloscopes, multimeters, function generators, component testers, and frequency counters comprise a selection of over 50 models. Products for TV servicing continue to be core products. Specialized products for circuit board testing and telephone product servicing complete the instrument line. Probes and accessories complement the instruments. B&K Precision is also the nation's foremost manufacturer of bench type variable voltage power supplies.

New for 1996 are a complete line of regulated DC power supplies, including voltage and current ratings never before available. The entire family of function generators is also brand new. A moderate cost pattern generator for computer monitors has been added. Instruments for automotive troubleshooting are new also.

B&K Precision has renewed its commitment to customer service with a toll-free number for ordering a catalog, ordering replacement parts, getting cost quotations on repairs and service, and obtaining technical advice concerning instrument selection, applications, and use. ■

Test all these...



CGA



EGA



VGA

640x480/60 Hz



VGA

640x480/60 Hz



SVGA

1024x768 I /87 Hz



SVGA

1024x768 NI /60 Hz



MAC II

640x480/67 Hz

For a lot less of these



\$\$\$

Introducing B+K's Model 1280 Video Generator

Our video signal generator sends crisp, clear patterns in all the most popular computer video formats. It includes built in 9 pin, 15 pin and BNC outputs to allow you to interface with any monitor. It uses battery or AC power so you can take it anywhere. Best of all, its patented new IC technology brings you all this for a remarkably low price.



Model 1280

Only \$429



(312) 889-1448, Fax: (312) 794-9740. Technical Support: (800) 462-9832

Circle (77) on Reply Card

QB Products Microwave Division

1260 Karl Court
Wauconda, IL 60084-1094
Contact your local QB distributor
or call 1-800-323-6856 Ext. 619
Fax: 708-487-2689

Look for your
1996
Product Catalog III
at your local
distributor in
January.



Part #VID2
Video Microwave Repair Course

QB Products Microwave Division was established in 1991 to fill the growing demand for replacement microwave oven components. QB Products' philosophy was simple . . . develop a complete line of high quality replacement components and offer them competitively to the service technicians through a network of professional electronic and appliance parts distributors nationwide.

This simple concept has paid off for QB Products, its distributors and for the technicians who now benefit from the fast, local service that is given at over 800 outlets throughout the United States, Puerto Rico, Canada, Mexico, South America, Australia and Europe.

QB Products has become the leader in aftermarket microwave oven replacement parts because of its commitment to quality and its innovative approach to addressing the needs

of the service technician.

Unlike other suppliers of generic microwave oven replacement parts, QB Products has on staff microwave oven engineers who have designed microwave ovens for over 20 years. Our engineers have been responsible for the cross-referencing of magnetrons and for the testing of all QB Products' components.

These tests are the same tests used by the manufacturers of microwave ovens to assure the technician that QB Products' components are of equal or better quality than the original components being replaced.

Another aid to the technician is the QB Products catalog of microwave oven replacement parts offered only by authorized QB Products' distributors. The catalog offers an innovative cross-reference guide for magnetrons, complete component data and cross-

referencing that makes component replacement easy as 1-2-3.

If you are not yet fixing microwaves but would like to, QB Products is offering the most comprehensive, up-to-date, and accurate training course available. "YOU CAN FIX YOUR MICROWAVE OVEN!" A Practical Video Guide to Safe and Successful Microwave Oven Repair, by J. Carlton Gallawa.

Presented in a clear, logical and progressive format, you'll receive 3 hours of practical education on videotape, plus a test and reference handbook. This course will enable the technician to not only troubleshoot and repair virtually any commercial or residential model of microwave oven, but it will also add additional big profits to your existing business.

Part #VID2 is available from your QB Products distributor for \$59.95. ■



Microwave Oven Test Instruments



Hassle-free Testing of Microwave Oven Components...

The Electronic Design Specialists Microanalyzer

- Measures up to 5kv AC or DC in two ranges
- Quick testing of high-voltage diode, capacitor, transformer and magnetron using high test voltages.
- Built-in semi tester checks triacs, transistors, SCRs and MOSFETS.

Part # EDS76 \$399



TEKNIK EMF/Microwave Tester

- Identifies and measures hazardous electromagnetic fields (EMF), microwave energy and extremely low frequency (ELF)!
- Safely tests for hazardous energy emitted by: computers, computer monitors, microwave ovens, and more!
- Tests cellular phone emissions tool
- Ultra-sensitive device for fast, accurate readings!

Part # EM205 \$39.95



Microwave Leakage Meter

This inexpensive device detects unhealthy microwave emissions from worn seals, doors, loose covers, etc. Easy to read 2 color meter.

Part # E30777 \$11.95



Magic Lights Lights Up to Show You What's Going On Inside Any Microwave Oven

- You'll know right away if microwave is working
- Checks power settings

Part # 4750 \$4.95



MAGNAMETER™ Gets the Job Done in Half the Time!

- Helps analyze magnetron operation, H.V. diode problem capacitors, transformer and also plate current
- No batteries, field tested, rugged construction.
- Flashing Neon light shows dangerous levels of voltage even after oven is off.

Part # E1173 \$149.95



Circuit Saver Stop wasting good fuses! Stop wasting time replacing good diodes!

- 1 AMP high voltage substitution diode (12,000 VOLT)
- 15 AMP substitution fuse/ breaker
- Unique high voltage warning and test indicator
- Troubleshooting time saver
- High Voltage test leads
- American Made
- Needs no battery

Part # E5975 \$39.95



Tri-Chek II™ Automatic Triac • SCR • H.V. Diode Tester

- Check All Types of Triacs*, SCR's, and H.V. Microwave Diodes
- Quick Troubleshooting Time Saver
- Rugged, Compact and Portable
- American Made
- Solid State Electronics
- Low Current Circuitry

Part # 4748 \$84.95



MICROWATT The latest revolution in microwave cavity power testing

- Eliminates time consuming interior cavity water tests
- Indicates power output of magnetron
- Rugged, compact and requires no batteries
- Expected delivery - Spring 1996

Part # 4760 \$124.95

Call 1-800-323-6856, Ext 619 For The Distributor Nearest You.

Computer basics

Ron C. Johnson

Have you ever been in that situation where everyone around you is talking about the details of a subject and you're afraid to admit you aren't familiar with the basics? Are you coming in a bit late on this whole computer craze and want to sort out some of the jargon?

If so, you've probably been looking through magazines and bookstore shelves for information on the basics of computers. Maybe you have noticed that a lot of the computer magazine articles you have read often seem similar. They assume you already are into the computing scene.

Quite a few books go the other direction and spend several chapters covering digital gates and the binary number system. You ask yourself how this relates to computers from your perspective. Often these kinds of books then jump into a whole bunch of incomprehensibly complex stuff about the registers and inner workings of the microprocessor chip.

In this article (and in subsequent articles) I hope to bridge some of the gaps I've mentioned. I also intend to answer some of the "why's" you might be asking yourself about the importance of knowing certain aspects of computer technology. I will assume that you have plodded your way through some of those basic concepts like the binary number system, digital logic levels, gates and flip-flops. If you haven't done that yet there are lots of inexpensive books on the subject. . . but you probably already know that.

What's in the box?

The fact is, computers are very complex, and their complexity is reflected in the many different levels of their operation. You can talk about computers on the fundamental level of binary one's and zero's, the mysterious and confusing level of machine code and CPU registers, the modular level of disk drives, motherboards and communications ports, or on a variety of levels in between.

Johnson is a journeyman electronics servicing technician and an instructor of technology at the Northern Alberta Institute of Technology in Edmonton, Alberta, Canada.

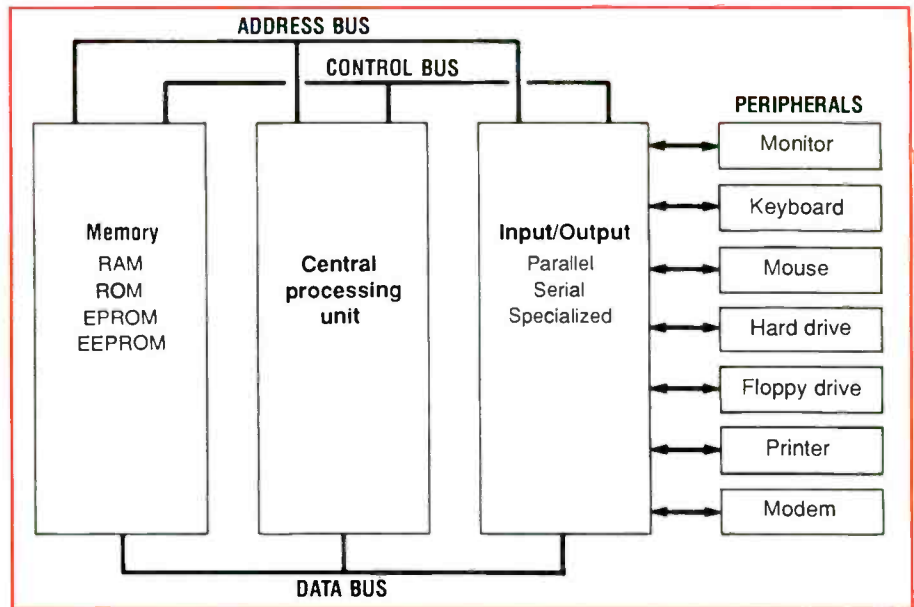

Figure 1. The three sections and three buses of a computer system.

To add to the difficulty, computers are more than hardware such as monitors, keyboards, RAM, ROM and I/O circuitry. Much of their complexity lies in the variety of software that makes them useful. Even more obscure is the fact that, to understand a computer system, you must grapple with the conceptual aspects of how the hardware and software work together. For example, memory and how it is designated, used and configured in any particular system.

In other words, if you don't understand computers, welcome to the club. There are very few people who understand them on every level. The trick is to decide what level you are interested in and work towards mastering that level.

To start out let's talk about the computer as a system. Where necessary we'll sneak down a level or two and try to bridge a few gaps between those levels. We'll also try to see why some of those details are important to us.

Hardware

Let's talk hardware first. It might be hard to believe considering the variety of "buzz-words" you've heard about com-

puter systems, but you can break the hardware down into just three sections: the central processing unit, the memory and the input/output section (Figure 1). Of course, there are several kinds of each of these—even the processor—but we'll get to all of that eventually. Let's consider the general operation of the processor first.

Processors

Everybody talks about the ubiquitous microprocessor chip, as if it were some mysterious device some guy with a long, white beard brought down from a mountain climbing expedition. What is a microprocessor anyway? Well, really it's just a fancy logic chip that will do a few very predictable things when you put the right combination of ones and zeros into it. Inside, it has several registers, a circuit that performs math, and other circuitry to control the flow of data in various ways.

By the way, you'll remember that registers are just a series of flip-flops that hold the state of their outputs when the input is removed. They are used as temporary memory locations and allow the data in them to be manipulated.

Each register has a different purpose;

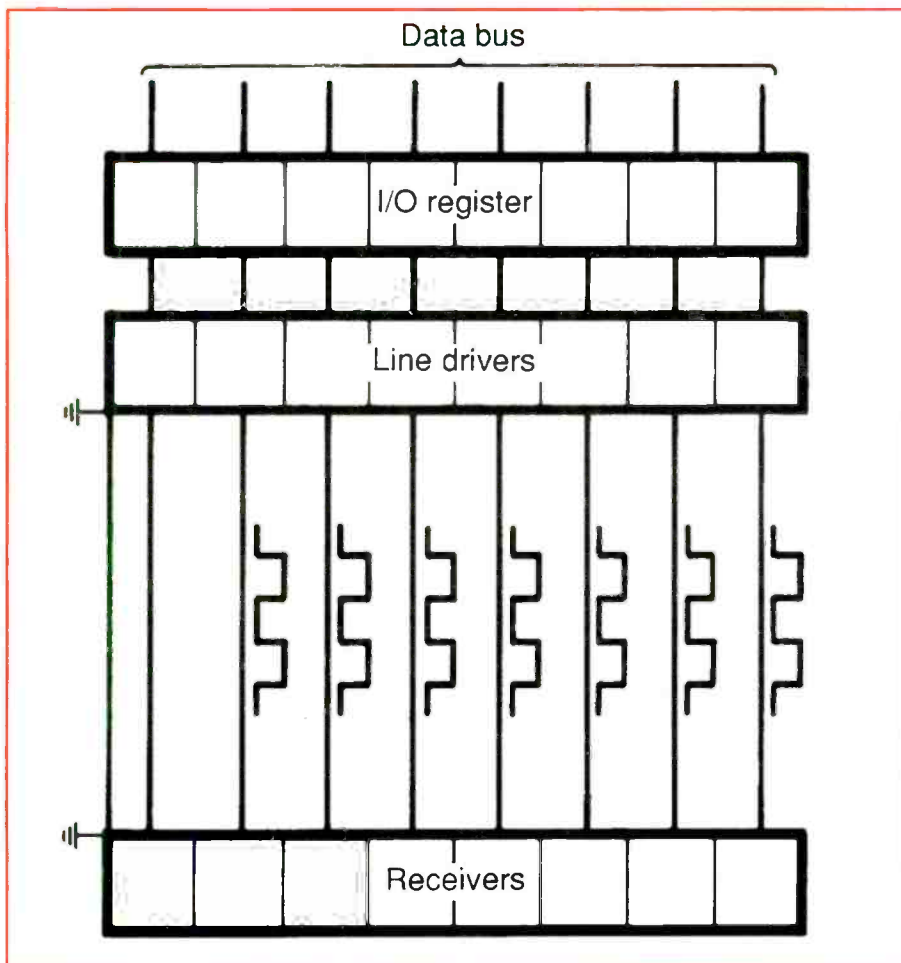

Figure 2. Parallel Data Transfer.

some to hold instruction codes (which tell the processor what to do), others that hold data, and others that remember which step in a series of instructions the processor is currently carrying out.

The central processing unit, or CPU as it is frequently referred to, has been built in such a way that it can carry out simple sequences when it recognizes an instruction code. For example, you might program it to receive an instruction to load a word of data from a certain location in memory into its accumulator register.

The processor has the ability built in to execute a series of actions that find that piece of data and put it into the accumulator. Useful computer programs perform many of these and other instructions one after another and very quickly.

The processor operates at a rate determined by the clock signal, which is just a square wave (or sometimes two square waves 180 degrees out of phase) running at a very stable frequency. Everything in

the computer is synchronized to the clock and the higher its frequency, the faster the computer is. (Of course, this is not the only factor that determines the speed of a computer, as we'll see later.)

Why is everyone talking about Pentiums, Power PC's and 68000 chips? The size and complexity of the microprocessor, its internal features and the amount of data it can access on each clock cycle determine its speed and efficiency. Over the last few years there has been a race by the manufacturers to produce more and more powerful microprocessor chips that could do more in less time.

Memory

The second section of the computer is the memory section. The memory we're talking about here is called primary memory, like RAM and ROM, not disk drives and such, which are considered secondary memory. Primary memory is really just a very large number of binary storage loca-

tions (locations where ones or zeros can be stored). It is used to store both programs and data and is organized into sections so that the different types of information can be kept separate.

RAM

Some kinds of information are temporary. RAM (Random Access Memory) is used to store this kind of information. Under processor control, data can be written to RAM memory, or read from it. There are a couple of different kinds of RAM memory: static, which is slower to access but simpler to construct, and dynamic, which is faster but requires special circuitry to maintain the data. RAM for most modern computers comes in modular form called SIMM's (single in-line memory modules).

There are two main things to consider when buying RAM for your computer: the amount and the speed. Usually, the more RAM you have the better, especially with most of the applications programs available today. (My first computer had 1024 bytes of RAM. The one I have today has 8,000 times as much and I'd like to have more!) The speed of the RAM you use is important too. The speed of the RAM should be fast enough to accommodate the speed of your processor.

ROM

ROM (Read Only Memory) is used to store permanent or semi-permanent information. There are several types of ROM memory. PROM, (Programmable ROM), which can have data "burned" into it but cannot be changed afterwards. EPROM (Erasable PROM), which has a window in the top to enable erasing the data with an ultraviolet light. This kind has to be removed from the computer to be erased and programmed and the whole memory must be re-programmed. EEPROM (Electrically Erasable PROM), can be erased and re-programmed while still in the circuit. There are other variations but these are the most common.

The importance of memory types

Why all this talk you hear about RAM and ROM and other types of memory? I've already mentioned the importance of the amount and speed of RAM. Knowing what kind of ROM memory is used in a

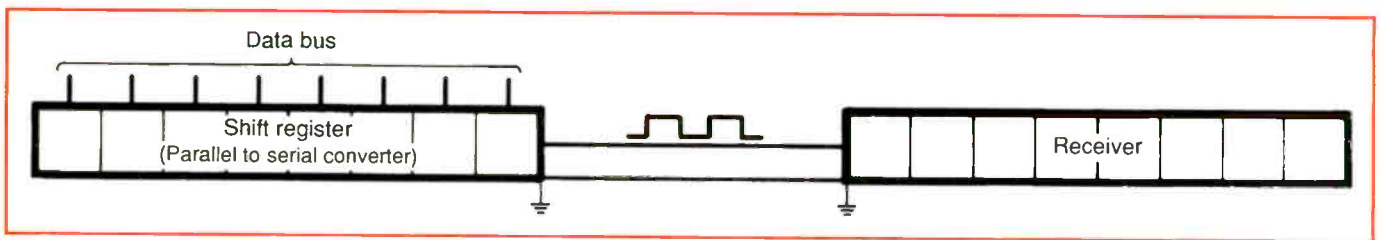

Figure 3. Serial Data Transfer.

system helps you to know what kind of information there is, how user data is kept safely stored when the power is off, and other important details.

In the case of the personal computer, data is stored long term on the hard drive or a floppy. In many microcontrollers there is no disk drive. All data is kept in either RAM or ROM. Usually EPROM is used for user programs that may need to be updated periodically. EEPROM is often used to store configuration data or to store data when the controller is powered down.

Input/Output

The input/output section of the computer is the part that allows it to connect to the real world. Input/output circuitry usually contains temporary registers (as well as other circuitry) that hold data. Input registers hold data until the processor can deal with it. Output registers receive the data from the processor and make it available to the outside world.

I/O can take several forms. Parallel data I/O takes data in the form the processor deals with, usually 8 bits (or multiples of 8 bits), and connects it to the outside world through eight individual conductors (these conductors are referenced to a ground conductor) (Figure 2).

Serial I/O takes the parallel data and converts it to be presented sequentially on a single wire (again, referenced to a ground conductor) (Figure 3). Serial I/O reduces the number of wires required in cables but increases the length of time necessary to send the data.

So far I've mentioned the registers, which hold I/O information, and the parallel to serial and serial to parallel interface circuitry. Input/output sections also contain the circuitry used to drive the output lines with the necessary voltage and current levels. Interfaces also often have

extra lines called hardware handshaking lines. These connections do not carry data but they allow the computer to coordinate the exchange of data with the receiving device (such as a printer).

Communicating with the printer

For example, the printer has a small amount of internal memory, called a buffer, to temporarily store data to be printed. When the buffer gets full, the printer puts a voltage on a handshaking line connected to the computer. The computer monitors this line and temporarily stops sending data until the buffer clears itself and the handshaking line goes low again. (More modern systems have moved away from hardware handshaking. Instead, control codes are sent back and forth on the data lines and are used to accomplish the same tasks.)

Built-in computer peripherals

Within the context of what we have been talking about here, I/O is the circuitry inside the computer itself that connects to external peripheral devices. The truth is, personal computers have many peripherals built into them. Hard and floppy drives, CD-ROM'S, video monitors, mouse and keyboard interfaces, sound cards, network cards, and a variety of other devices are all really peripherals that interface with the computer itself through specialized I/O systems.

External peripherals that are fairly generic (such as printers) are interfaced to the computer through standardized I/O such as a parallel Centronics interface. Other generic peripherals (such as external modems) connect to the computer through the RS-232 serial interface.

Microcontrollers

One more thing should be mentioned about the internal sections of microcon-

puters: as the technology has developed lots of variations and levels of complexity have been created. One quite revolutionary aspect of this technology has been the development of microcontrollers (as opposed to microprocessors).

The difference between the two is subtle, but important. Microprocessor chips, (especially the early ones, before these distinctions began to blur) are processors only. Microcontrollers, on the other hand, are often complete (albeit, comparatively simple) computer systems. They have built in RAM, ROM (sometimes EPROM), parallel and/or serial I/O and, on some of the newer chips, analog to digital and digital to analog converters and communications circuitry.

Using these chips, complete controllers can be created with very little additional circuitry. Very often manufacturers have custom microcontrollers built for their application, as in the case of consumer electronics such as VCR's, camcorders and televisions.

Buses

Obviously the three sections of the basic computer we have been discussing have to be connected together in order to interact and do their jobs. This is where the buses come in. A bus is just a collection of conductors on the printed circuit board of the computer. All the main components of the system are connected in parallel with the bus so that the signals on the bus are available to all those components at the same time.

At the beginning we decided to assume that you are familiar with the basics of digital logic, which operates using two voltage levels: zero and five volts. In the case of the circuitry used to put signals onto bus lines, a third state is added and devices called tri-state buffers are used. This third state should really be defined

as the absence of a state. Bus driver circuits can pull the bus line down to zero volts, up to five volts or effectively disconnect themselves from the bus so they have no effect. This is called a high impedance state because the driver output looks like an open circuit to the bus.

Any device that is not currently putting signals onto the bus stays in the high impedance state. Only one output can control a bus line at a time and that output will either put a logic zero or one on the bus. There are actually three buses in a typical computer system: the data bus, the address bus and the control bus. All three buses are connected (in parallel) with the processor, the memory and the I/O.

The data bus

The data bus carries the actual information to and from each of these sections. Because the data can go into and out of the processor we call the data bus bidirectional. One of the factors that affect the speed of a computer is the size of the data bus, or how wide it is. Computers deal with binary data in multiples of 8 bits. As microprocessors have developed, the data bus size has gone from 8 bits to 16 and on to 32 bits. Speed is increased because the amount of information that can be moved around the computer on each clock cycle is much greater with a large data bus size.

The address bus

The next bus, the address bus, is unidirectional because the processor puts the address of the memory location it wants to read from or write to onto the address bus. DMA (direct memory access) is an exception to this but we'll overlook it for now. Each unique binary code specifies a separate memory location or I/O register. The larger the number of lines in the address bus the more memory the computer can access. Again, newer processors use larger address bus sizes, which allows them to access a great deal more memory than earlier chips could access.

The control bus

The control bus is really a group of lines, each with a separate purpose. Some lines are controlled from the processor, some from elsewhere.

One control bus line is the READ/

WRITE line. When the processor wants to read data from a memory location or I/O register it pulls this line high. When it wants to write data to that location it pulls the line low.

Another line in the control bus is the clock. As I mentioned before, the clock signal is used to synchronize the activities of the computer.

Still another line is called the interrupt line. If an I/O device pulls this line to its active state it signals the processor that the I/O device needs attention. The processor then finishes its current instruction and runs an interrupt routine.

There can be several interrupt lines in the control bus (depending on the microprocessor) that have different priorities. Interrupts with higher priorities are serviced first, lower priorities must wait.

More to come

This quick look at the sections and buses of a computer is grossly oversimplified to be sure but, for those who are new to this, it should be helpful in getting started. In a future article we'll take a closer look at peripherals and deal with a few more specifics that relate to IBM compatible personal computer systems. ■

Books

***The 7th Annual Computer Industry 1994-95 Almanac*, Egil Juliussen Ph.D. and Karen Petska-Juliussen, 800 pages, \$60.00 hardcover, \$50.00 paperback, \$60.00 CD-ROM**

The Computer Industry Almanac is an annual reference book about the computer industry. The book offers thousands of facts that summarize the whole industry. There are databases such as: computer companies, computer publishers, associations, organizations and users groups, testing companies, conference companies, publications, research companies, PR and market communications agencies, conferences, and people.

The Almanac is full of rankings and awards for companies, people and products, which have been excerpted from the business and computer press. One of the most popular chapters is the salary and wealth rankings of the top computer people as well as the average salaries for various computer-related occupations. It has summaries of computer market forecasts for hardware, software and peripherals.

An introductory chapter explains the structure of the computer industry and defines the computer categories from personal computers to supercomputers. Software, peripherals and service products are also categorized and defined. Additionally, there is a history of the computer, educational statistics, employment data, computer comedy and more. *The Computer Industry Almanac* was compiled using PCs and desktop publishing and all products used are listed in the *Computer Industry Almanac*.

Computer Industry Almanac, Inc., P.O. Box 600,
1639 Logan Creek Drive, Glenbrook, NV 89413

***Implementing Wireless Networks*, By Martin Nemzow, Mc-Graw-Hill, Inc., 320 pages, 75 illustrations, \$50.00 hardcover**

Thanks to new standards and frequency bands, wireless networks are poised for enormous growth. Dataquest predicts that 3.2 million network connections will be in place throughout the U.S. by 1997. In the new book, *Implementing Wireless Networks*, author Martin Nemzow offers network administrators a wide range of practical solutions for setting up wireless networks in offices, file operations, retail settings, factories, and warehouses.

For each application, Nemzow explains how to modify the wired network for wireless access and connect the components and software. Fine-tuning instructions, diagnostic and troubleshooting information, and performance enhancement techniques are also discussed in detail.

Readers will learn everything they need to know to implement wireless networks for: site-to-site connectivity, intra-site mobility, E-mail on the road, inventory operations, global positioning services, ship-to-shore connectivity, product coding and tagging, shipping/receiving and many other applications.

Filled with schematics, charts, and drawings, this handbook is a resource for network professionals who are working for organizations connecting various locations via networks or providing wireless services to mobile employees.

Mc-Graw-Hill Inc., Professional Book Group,
Blue Ridge Summit, PA 17294-0850

What Do You Know About Electronics?

An old question about resonance, with a new slant

By Sam Wilson

Before getting into the subject matter of this article, let me provide a little bit of history regarding the circuit of Figure 1. Some years ago that illustration was used in a CET test. It was in the test because the circuit was used to tune a trap in a television receiver.

At that time, I was preparing CET tests and answering the questions that technicians sent to ISCET. The question most asked about the circuit was: "How can a variable resistor be used to vary the frequency of a tuned circuit?" An explanation (similar to the one in this article) was printed in an ISCET newsletter. Later, it was put into CET practice tests.

Although the trap mentioned above is no longer used, the circuit still warrants your attention. In every practical tuned circuit there is resistance in the inductor. That resistance can affect the operation of a parallel resonant LC circuit. It is represented by R in Figure 1.

There is some math involved so you should put on your thinking cap. For readers who don't like math, it isn't essential that you be able to generate the math, but, I am sure you will find it useful if you read the material carefully. For readers who hate math, read the sentences that are in italics and study the illustrations.

It is unfortunate that some books written for technicians treat parallel-resonant circuits by using the same equation for the resonant frequency used for series-resonant circuits (See Figure 2):

$$f_r = \frac{1}{2\pi\sqrt{LC}}$$

This equation is only valid when the resistance in the two parallel branches is so low that it can be disregarded! The parallel resonance of circuits with resistance

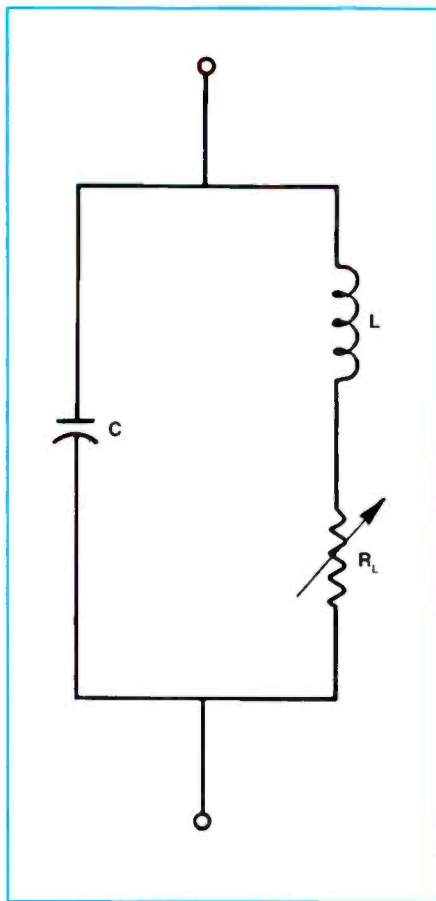

Figure 1. In this parallel resonant LC circuit, R represents the resistance of the coil, L.

in one or both branches has been discussed before in this column. When the resistance in one or both branches cannot be disregarded the correct equation is:

$$f_r = \frac{1}{2\pi\sqrt{LC}} \sqrt{\frac{R_L^2 C - L}{R_L^2 C - L}}$$

How does the resistance in the RL branch affect the resonant frequency and the bandwidth of the circuit in Figure 1?

In a practical circuit there is always

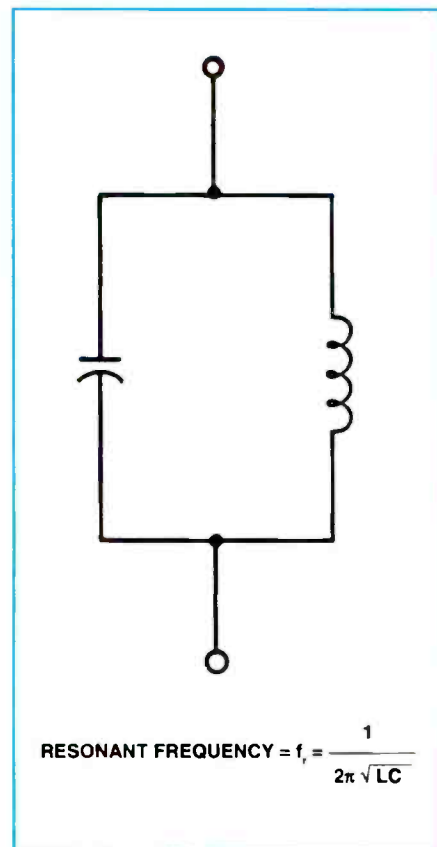

Figure 2. The equation for parallel resonance shown here, $f_r = 1/2\pi(\sqrt{LC})$, is only valid when the resistance in both branches is so low that it can be disregarded.

resistance in the windings of the inductor. That resistance can be represented by a separate resistor (R_L) as shown in Figure 1. When there is no resistance in the capacitor branch, the equation for resonance is obtained by setting R_C equal to zero in the above equation, which yields:

$$f_r = \frac{1}{2\pi\sqrt{LC}} \sqrt{\frac{L - R_L^2 C}{L}}$$

(Note: in order to get a positive denominator the number under the radical has

Wilson is the electronics theory consultant for ES&T.

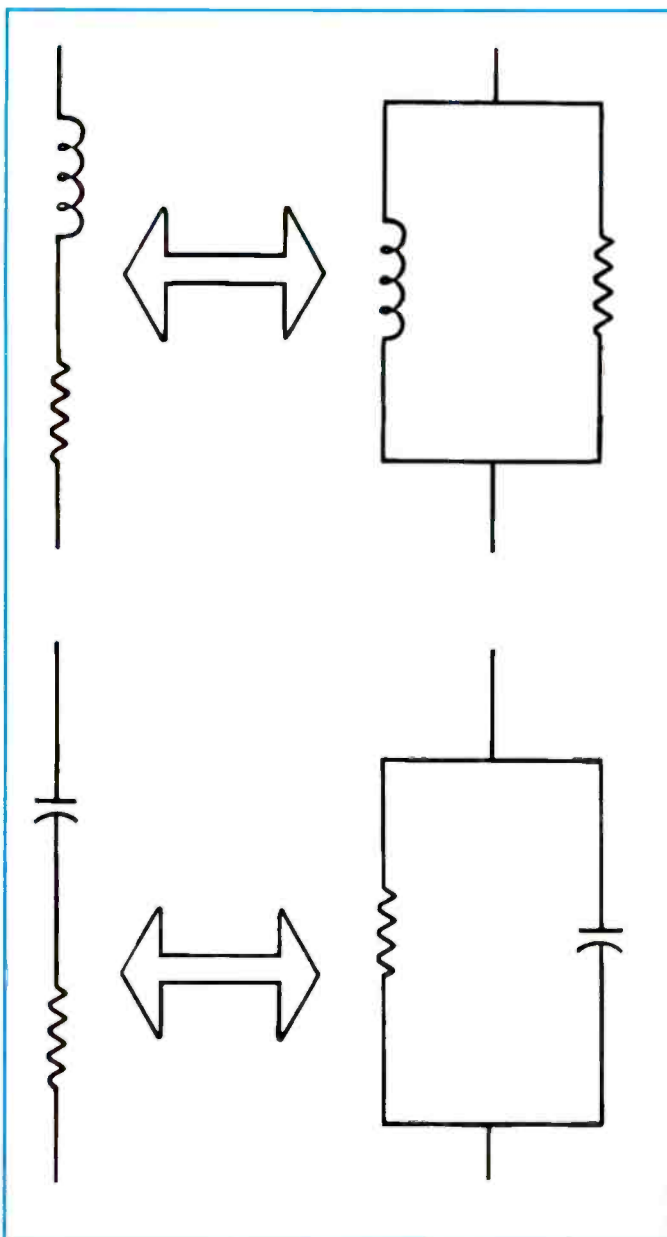

← **Figure 3.** These diagrams illustrate the theorems in electrical circuits that state; any circuit consisting of a reactance in series with a resistor can be converted to an equivalent parallel circuit with a reactance and resistance in parallel, and any circuit consisting of a reactance in parallel with a resistor can be converted to an equivalent series circuit with a reactance and resistance in series.

Figure 4. The triangles in this figure represent the relationship among the parameters in equivalent series and parallel RL circuits. ↓

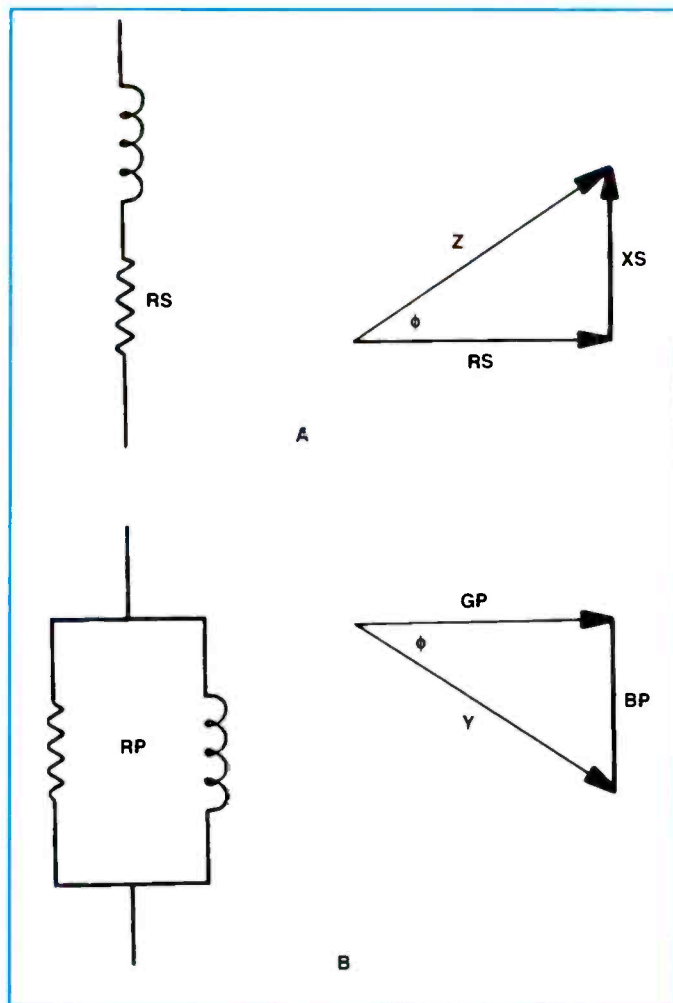

been modified by multiplying the numerator and denominator by -1).

Observe that the resonant frequency of the circuit in Figure 1 depends directly on the resistance of R_L in the inductive branch. Therefore, increasing the resistance of R_L increases the resonant frequency. If that resistor is variable it can be used to adjust the resonant frequency of the circuit.

If you allow R_L to increase without limit, the resonant frequency will become infinitely high. Carrying that idea to the circuit in Figure 1, if R_L is increased without limit it becomes an open circuit. The only thing left in the circuit is C. Apply it to the equation in Figure 2. The value of

L is zero because it is in an open circuit, so, the resonant frequency is infinite.

Bottom line: Increasing the resistance of the resistor in the circuit in Figure 1 causes the resonant frequency to increase.

How does the resistance in the R_L branch affect the impedance of the circuit (Figure 1)?

Now we will move on to the effect of R_L on the impedance of the circuit of Figure 1. If you increase the resistance of the resistor in Figure 1, what will happen to the impedance of the circuit?

There are a number of ways to approach this problem. For the method used here it will be necessary to understand two basic

theorems in electric circuits:

Any circuit consisting of a reactance in series with a resistor can be converted to an equivalent parallel circuit with a reactance and resistance in parallel.

and

Any circuit consisting of a reactance in parallel with a resistor can be converted to an equivalent series circuit with a reactance and resistance in series.

Figure 3 illustrates the meanings of these theorems. It is necessary that the equivalent circuit in each case presents exactly the same impedance and introduces the exact same phase angle as the original circuit.

The two triangles in Figure 4 are for a

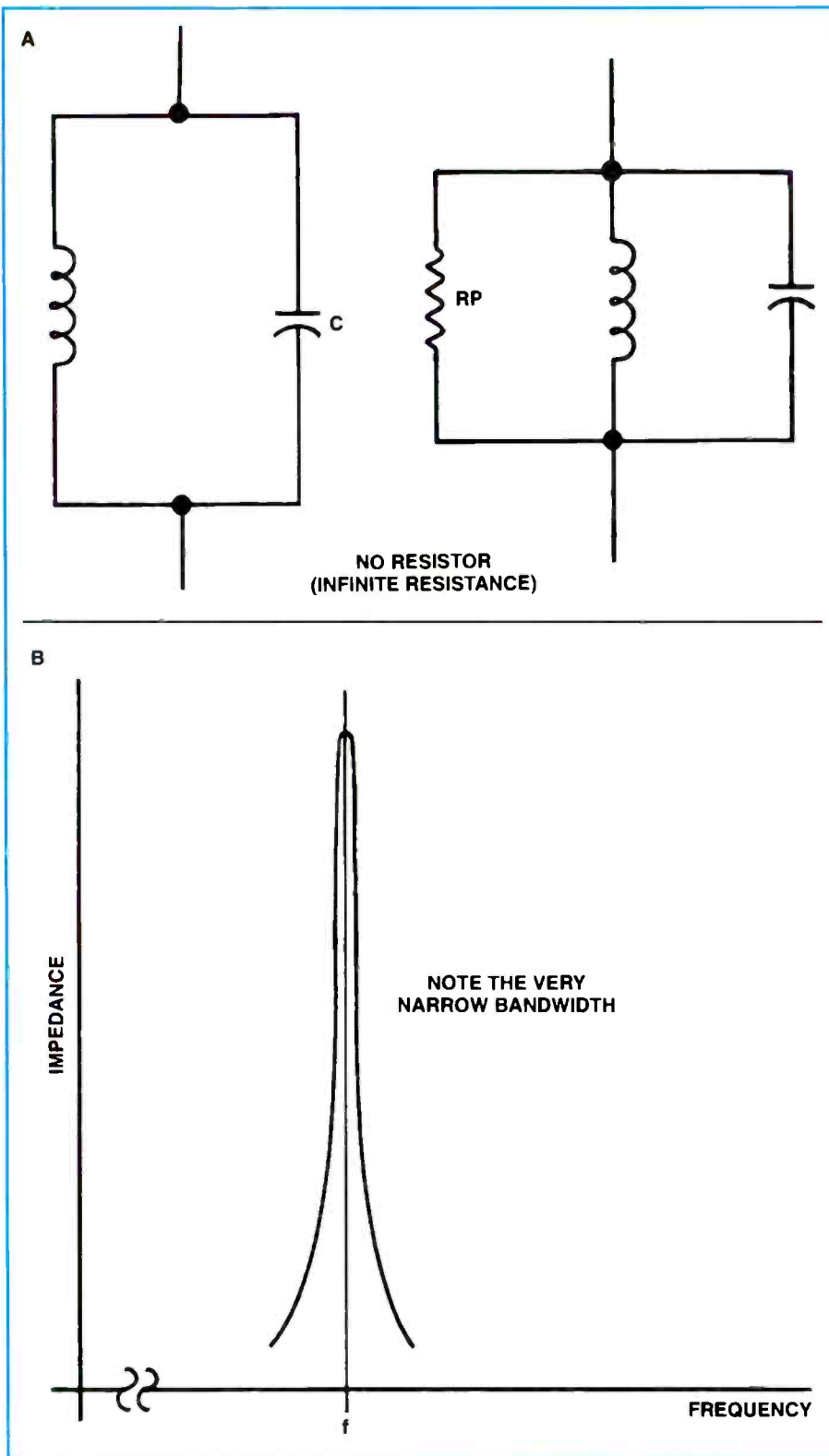

Figure 5. If the parallel resistance in this circuit increases without limit, it will become infinite, leaving just the parallel LC circuit. The parallel LC circuit has extremely high impedance and a very narrow bandwidth.

series circuit (A) and parallel circuit (B). If they represent equivalent circuits they must have the same phase angle (θ) and the same impedance:

$$\theta_S = \theta_P \text{ and } Z_S = Z_P$$

For the series circuit:

$$\cos \theta = \frac{R_S}{Z}$$

For the parallel circuit:

$$\cos \theta = \frac{G_P}{Y_P}$$

The absolute value of admittance is

equal to the reciprocal of the absolute value of impedance, so, that last equation can be written as:

$$\cos \theta = \frac{Z}{R_P}$$

Setting the two equations for $\cos \theta$ equal:

$$\frac{R_S}{Z} = \frac{Z}{R_P}$$

from which:

$$R_P = \frac{Z^2}{R_S} = \frac{R_S^2 + X_S^2}{R_S}$$

That can be written as:

$$R_P = \frac{R_S^2}{R_S} + \frac{X_S^2}{R_S}$$

It is now obvious that increasing R_S without limit will cause R_P to also increase without limit. Of course, if you increase R_S without limit in the series circuit, R_P will increase without limit in the parallel circuit.

Well, let it go to infinity (which is an open circuit). All you have left is the parallel LC circuit which has an extremely high impedance and a very narrow bandwidth (Figure 5).

Bottom line: Increasing the resistance of R in the circuit of Figure 1 will cause the impedance of that circuit to increase, also

Bottom line: Increasing the resistance of R in the circuit of Figure 1 will cause the bandwidth of that circuit to decrease.

Exercises like this will keep you sharp

My mother is in a rest home and I have a lot of opportunity to talk to older people when I go to visit her. Some of those people are very sharp. They know what is going on in the world, and they have intelligent things to say about it. Others are content to sit and stare and wait.

There is a theory that the mind will atrophy if you don't use it. Every time I come away from that nursing home I say to myself, "don't let it happen!" So, once in a while I put some kind of mind exerciser into WDYKAE? The math in the above exercise is an example.

Donner and blitzen

If you like thunder and lightning you would love Florida. This place is the lightning capitol of the world. Some people become complacent about it after they have lived in Florida for a few years. That's not a smart thing to do.

Every year we read about people get-

ting killed by lightning on the golf course or on the beach. I realize that happens in other parts of the country, but, if you go by statistics you have a much better chance of getting struck here. We average 100 thunderstorm days a year compared to 50 per year in the midwest and about 10 per year on the west coast. (That information comes from a company called General Semiconductor Industries, Inc. They make transient voltage suppressors, so, I guess they ought to know).

A heavy-duty lightning bolt can consist of 150,000 amperes! The average is about 20,000 amperes. That is nothing to be complacent about. A 100-meter line interconnecting a terminal with a main-frame can have several hundred volts induced by a nearby lightning strike. (That is also from the same company.)

O.K. - maybe you knew all of that stuff about lightning. But, did you know that if you are caught outside in a thunderstorm you should *not* lay flat on the ground? That gives you maximum contact with earth ground.

What you are supposed to do, is get into a position with only your knees and hands touching the ground. Remember that reducing the cross-section of a conductor increases the resistance of a body. That information comes from a local newspaper. Also, a car with wet tires *can* get struck by lightning! ■

ES&T Calendar

International Winter Consumer Electronics Show
January 5-8, 1996
Las Vegas, NV

Mobile Electronics Show
April 19-21, 1996
Orlando, FL

CES Orlando '96—The Digital Destination
May 23-25, 1996
Orlando, FL
703-907-7500

CES Habitech
May 23-25, 1996
Orlando, FL 703-907-7500

1996 CES Specialty Audio and Home Theater Show
May 23-25, 1996
Orlando, FL
703-907-7500

Test Your Electronics Knowledge

By Sam Wilson

Over a period of 12 months my average score on Test Your Electronics Knowledge quizzes is usually over 99%. Big deal, you say? Since I write the questions I should get 100%? Not necessarily so. Sometimes something happens between the time I make up my handwritten copy and the time the article comes out in print.

For example, question number 3 in the October 1995 TYEK: "For an FM signal with a pure sinewave modulating signal, '?' = "

I don't even understand the question, and the original is lost, so I took off ten points. If you got that one right I would appreciate a little help. Here's this month's quiz.

1. According to the Nyquist theory, to properly resolve an audio signal of 20,000 Hertz into a digital signal, the audio signal must be sampled at a rate of at least _____ Hertz.

2. When signals contain frequencies that are higher than one-half the sampling rate, the condition is known as _____.

3. The average current in a lightning strike is about
A. 200 amperes.
B. 20,000 amperes.

C. 200,000 amperes.
D. 2,000,000 amperes.

4. A 100% efficient radiator and absorber of radiant energy is called a _____.

5. What is the name of a unit of length measurement equal to 3.3937×10^{-9} inches? _____

6. The variable resistor in Figure 1 has a range of 0Ω to 300Ω . What is the range of resistance values between X and Y?

7. Which is longer; 10 centimeters or 10 inches? _____

8. Right or wrong? - Increasing the gain of an audio amplifier in a receiver will improve the signal-to-noise ratio.

9. Right or wrong? - Adding an antenna to a radio receiver will decrease the RF output noise. _____

10. The newer power supply voltage for integrated circuits is not 5V but

A. 10V.
B. 5.0V.
C. 3.6V.
D. 0.5V.

Bonus Question:

$356_{16} = \text{_____}_{10}$

Wilson is the electronics theory consultant for ES&T.

(Answers on page 67)

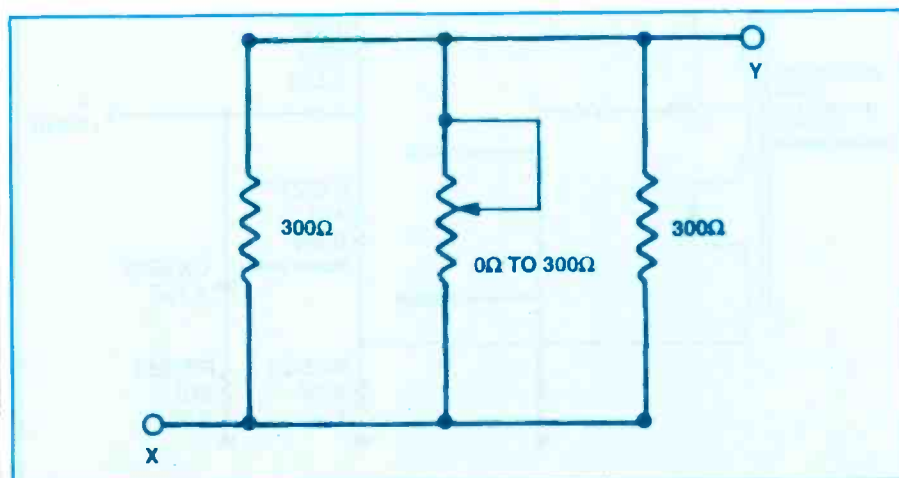

Figure 1. What is the range of values that will be measured between X and Y, as the variable resistor is varied between 0Ω and 300Ω .

Zenith Model SB1923W, Sams Photofact 2565

By Dudley Overton

This TV set would go into high-voltage shutdown a few seconds after the "on" button was pressed. When diode CR3209 was disconnected to defeat the shutdown circuit, the set would operate normally.

I increased the ac supply voltage with a variable transformer while checking voltages in the horizontal circuits. With the ac line voltage at 120V, the high voltage was 25KV, which was within specifications, and the output from the STR-380 regulator was exactly 123V. Moreover, all voltages derived from the horizontal output transformer agreed with those shown in the Photofact. I suspected a fault in the shutdown circuits, but all components checked normal. With frustration increasing, I went back to the Photofact. This gave me a couple of clues.

First of all, the service instructions in the Photofact state that if the set operates normally when CR3209 is disconnected

to defeat the shutdown circuit, the technician should troubleshoot the high voltage section, TX3204 (horizontal output transistor) and associated components. The other clue was RX3214, a 2% resistor. No manufacturer uses a 2% resistor unless the resistance is critical. Tight tolerance resistors are too expensive to use indiscriminately.

Moreover, RX3214 is electronically and physically close to RX3217, and both resistors have an X following the R in the part number, which means that they are critical to the safety of the set.

Armed with this information, I began to check resistors and capacitors on the horizontal sweep module, part 9-351. I discovered that resistor RX3217, 470Ω, 1/2W, had increased to 3200Ω. After I replaced this resistor and turned the set on, normal operation had been restored. A jumper across RX3235 confirmed that the shutdown circuit was operating.

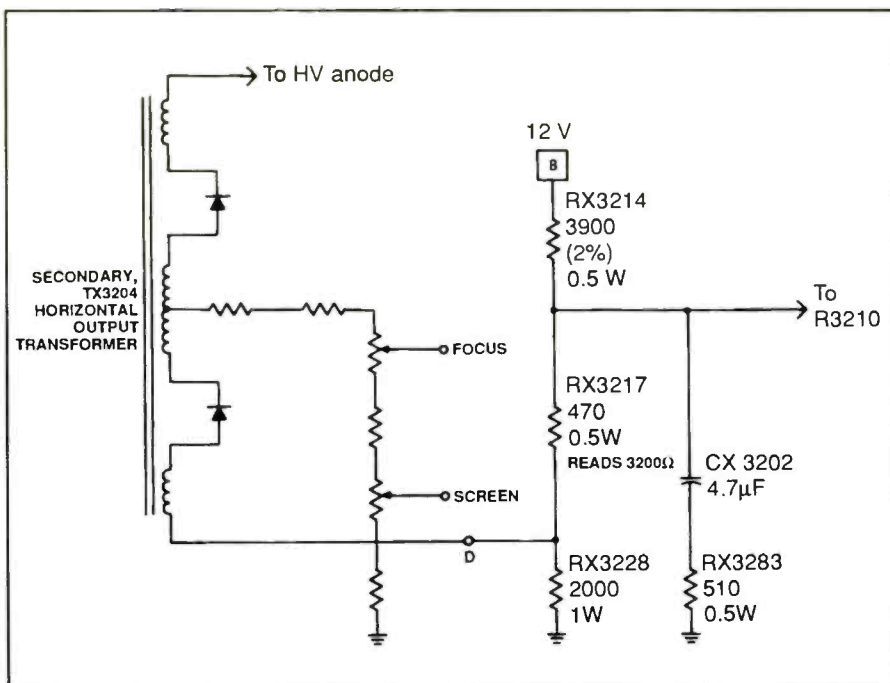

GE

VG7620VCR-270

GOLDSTAR

NC-4JA3572
580.41185903572
580.430485903572

MAGNAVOX

PR1914C1213567
PS1952C1213576
PS1962C1213576
TS2572C2023573
VR1820A(sim to)VCR-270
VR9820A(sim to)VCR-270
VR9822A(sim to)VCR-270
VR9825A(sim to)VCR-270
19P601-00AA3567
19P602-00AA3576
19P621-00AA3576
19PR14C1213567
25P506-00AA3573

PANASONIC

ANEDP2383569
AREDP2403569
CT-2752SFT3569
CT-3152SFT3569

PHILCO

P1324CR1013570
P1324CR1023570
VT3120AT01(sim to)VCR-270
VT3124AT01(sim to)VCR-270

RCA

CTC177AA33579
F25104WTFE13579
F25104WTJX13579
F25104WTTX13579
F2510BKFE13579
F2510BKJX13579
F2510BKTX13579

SANYO

AVM-19553575
AVM-20053566
G4Z-200503566
G6A-195503575

SHARP

13G-M603571
20F-S40R3568
20F-S50R3568
25G-M603578

SYLVANIA

VC4120AT(sim to)VCR-270

ZENITH

SR1941Y3577

Test Your Electronics Knowledge

Answers to the quiz

(from page 65)

1. 40,000 Hertz. The *minimum* sampling rate is twice the highest frequency being digitized.

2. aliasing (by definition).

3. B. (See What Do You Know About Electronics? in this issue).

4. black body. It is a term used in optoelectronics.

5. Angstrom. It is also defined as being 10^{-10} meters.

6. 0Ω when the variable resistor is set

to 0Ω . 100Ω when the variable resistor is set to 300Ω .

7. 10 inches. Remember that one inch equals 2.54 centimeters. So, 10 inches = 25.4 cm.

8. Wrong. Increasing the gain will also increase the noise.

9. Wrong. Any time you add resistance, (even antenna resistance) to the antenna terminals you add noise. It *sounds* less noisy because you increase the signal-to-noise ratio.

10. C. The lower voltage results in less heat to get rid of.

Answer to the Bonus Question: 854₁₀



Is there a long lasting solution for improving the performance and reliability of switches and connectors?

See CAIG ad on page 68

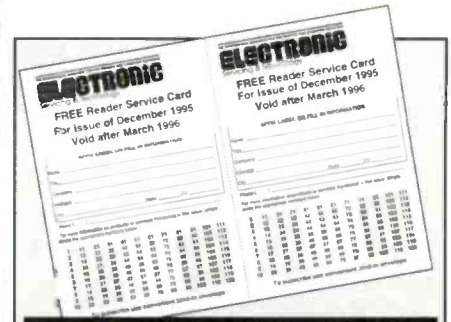

Use your free Reader Service card for more information on companies advertising in this issue.

Come Out of the Dark.

Brighten up your business with wholesale MasterCard/Visa processing rates offered through NESDA and U.S. BankCard Center (USBC), with discount rates as low as 1.78%. For more information about NESDA and this money-saving program, complete and mail the following to NESDA:

Name _____
 Business _____
 Address _____
 City _____ State _____
 Zip _____
 Phone _____

National Electronics Service
NESDA
 Dealers Association, Inc.

2708 W. Berry St.
 Ft. Worth, TX 76109
 (817) 921-9061

Improve Your Form.

3/5 Part

A continuous feed form used for customer COD service, parts/accessory sales receipts, and warranty billing. Includes technician hard copy and set tag. Available in 3-part (N3CS) and 5-part (N5CS) format.

5 Part

A continuous feed 5-part (N5CN) form for warranty billing that does not include a set tag.

Discounts Carbonless NESDA Forms are available to NESDA members at additional savings. For pricing information and samples, contact Moore Business Products at the number below.

The NESDA Form

Moore Business Products
 (800) 433-5557

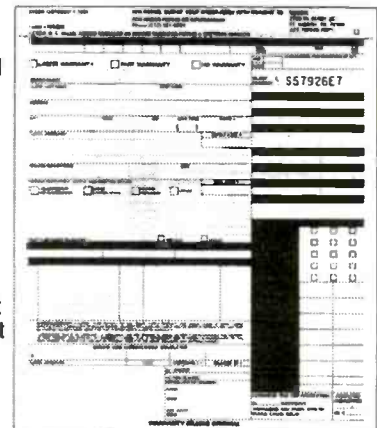

CAIG LABS

Creating Environmentally-Safe Chemical Products for Manufacturing, Maintenance & Service!

CAIG LABORATORIES, INC., established in 1956, supplies high performance chemicals and soldering apparatus for electronic and electrical applications such as: Audio, Video, Computers, TV, Automotive, Marine, Avionics, Telephone, Security, Photography, Communications, etc.

CAIG has reformulated all aerosol cans with ozone-safe propellants and continues to expand their product line with environmentally-safe aerosols, alternative solvents and convenient non-aerosol applicators.

Companies worldwide rely on CAIG products in their manufacturing processes, service departments and recommend the use of CAIG products in their maintenance procedures.

Use what the Manufacturers Use!



- ProGold** - Next generation contact cleaner that improves conductivity, preserves & lubricates electrical connections - *Only product that penetrates plated surfaces and molecularly bonds to base metals.*
- DeoxIT** - Fast acting deoxidizing solution that cleans, preserves, lubricates and improves conductivity on connectors and contacts. Use as a general purpose treatment.
- PreservIT** - Seals & lubricates clean/new connectors/contacts.
- OpticALL** - Anti-static cleaner & preservative for glass, plastic & metal.
- StaticALL** - Neutralizes static buildup - protects equipment.
- DustALL** - Precision air duster. Remove dirt, dust & particles.
- FreezALL** - Locates intermittents, cools circuits to -54°C.
- CircuitWriter** - Conductive ink dispenser pen, makes traces on most surfaces.
- CircuitSealer** - Conformal coating pen, protects & insulates.
- Caikleen IPA** - Ultra-pure alcohol for cleaning & degreasing.
- Caikleen 41** - Contact cleaner/degreaser - approved TF replacement.
- Caikleen TRP** - Degreaser/Cleaner/Defluxer - citrus-based.
- Caikleen A/V** - Cleaner for magnetic & optical read/write heads.
- Caikleen RBR** - Rubber cleaner/rejuvenator for rollers & platters.
- Caishield S7** - Metal sealant & protectant for nonferrous metals.
- Caikote EMI** - Conductive coating - shields against EMI/ESD.
- ElectricALL** - Similar to DeoxIT - more deoxidizing and less preserving properties.
- MechanicALL** - Concentrated anti-corrosive/tarnishing lubricant.
- Cailube MCL** - Moving Contact Lubricant for faders, switches potentiometers & other sliding surfaces.
- Cailube Pastes** - semi-solid formulations for cleaning, protecting & lubricating. Available with copper, quartz, graphite and without particles.
- Cailube X105** - Precision instrument oil, contains silicone.
- Cailube 360** - Multipurpose, concentrated, high penetrating oil/additive.
- Lint-Free Accessories** - Lint-free cloths, swabs, cleaning brushes and other applicators and accessories.
- Soldering Apparatus** - solder pots, wave solder pots, dip coating pots, plastic welding & cutting tools, modular ovens & conveyor systems.

CAIG Products . . . used by those who demand the best!

Ampex	Federal Express	Honeywell	Switchcraft
Boeing	Fluka Mfg. Co	McIntosh Labs	Tektronix
Diabold Inc.	General Electric	Motorola	Texas Instruments
Dolby Lab.	Hewlett Packard	Nakamichi	Xerox Corp.



16744 West Bernardo Drive
San Diego, CA 92127-1904
TEL: 619 / 451-1799
FAX: 619 / 451-2799

1-800-CAIG-123

Circle (53) on Reply Card

Literature



PC board fabrication products brochure

The 3M Industrial Tape and Specialties Division is now offering a new, free brochure entitled "3M Printed Circuit Board Fabrication Products." The full-color brochure features six categories of tapes including: planting tapes, fume and splash protection, hot air leveling tapes, photographic preparation tapes, flexible circuit rigidizing, and maintenance sorbents.

Everything from silicone adhesive tapes to negative and positive film tapes to thermally-conductive high performance tapes is included in this free brochure.

Circle (100) on Reply Card

Catalog features electronic tools

A new catalog of assembly tools and accessories has been introduced by ASG, a Division of Jergens, Inc.

This revised and expanded catalog con-



Cable to connector cross reference guide

RF Industries' new catalog presents an easy cable to connector cross reference featuring Belden, Alpha, Times cable to a wide variety of RFI connectors ranging from BNC to SMA.

This guide enables the user to easily select the appropriate RF connector to match the cable they're working with. The catalog is organized first by cable groups and second by the types of RF connectors available for these groups. The connectors are then divided into sub-groups by type.

Circle (104) on Reply Card

tains 42 pages of the company's complete line of controlled torque electronic screwdrivers and accessories for assembly and service. ASG inline screwdrivers feature a combination of low voltage power and advanced electronics. Precise torque repeatability under production conditions is assured by precision clutches which automatically stop rotation the instant a pre-set torque is reached,

High speed drivers and push-to-start tools are part of a comprehensive line which includes tools for portable and robotics applications, vacuum pick ups and accessories, transformers and controls, torque testers, clean room assembly tools and special inline tool attachments.

New products include variable speed control boxes, plug-in (110V) drivers, computerized torque testers that generate SPC data, and torque arms for light duty assembly work.

Circle (101) on Reply Card

Worldwide web site

Dynamic Learning Systems has just established a site on the World Wide Web. The URL is: <http://www.dlspubs.com/home.htm>. You'll be able to find articles, learn about the company's newsletter; The PC Toolbox, and find detailed information about a variety of PC troubleshooting books. There will also be provisions for ordering subscriptions and back issues of the newsletter.

Like most web sites, this one is regularly under construction, and you will see much more information on the site in coming months.

Circle (102) on Reply Card

Classified

Classified advertising is available by the word or per column inch.

By-the word. \$1.65 per word, per insertion, pre-paid Minimum charge is \$35 per insertion. Initials and abbreviations count as full words. Indicate free category heading (For Sale, Business Opportunities, Miscellaneous, Wanted). Blind ads (replies sent to ES&T for forwarding) are \$40 additional. No agency discounts are allowed for classified advertising by the word. Contact Kirstie Wickham at 516-681-2922 to place your classified ad (by-the-word). Mastercard, VISA, American Express and Discover are accepted for FAX or mail orders.

Per column inch (classified Display): \$235 per column inch, per insertion, with frequency discounts available, 1" minimum, billed at 1/4" increments after that 10" maximum per ad. Blind ads are \$40 additional. Reader Service Number \$25 additional to cover processing and handling costs. (Free to 4-inch or larger ads.) For more information regarding classified display advertising please call 516-681-2922. Optional color (determined by magazine) \$150 additional per insertion.

Send your order, materials and payments to:

Electronic Servicing & Technology, 76 North Broadway, Hicksville, New York 11801 Attn: Classified Department
Phone: 516-681-2922 FAX: 516-681-2926

FOR SALE

>>>>STILL - THE LARGEST TIP DATABASE - >>>17,350 TECH TIPS<<< VALUABLE, TIME SAVING, TECHNICAL REPAIRS for servicing TV's, VCR's, Projection TV's CAMCORDER's & other electronics, organized in an easy to use Computer Program - THE TECHNICAL TIP REPAIR Program. >>>PROFESSIONAL BOARD & COMPONENT LEVEL REPAIRS <<< ADD your own tips. PRINT tips BACKUP & save your own tips. Owners of our COMPUTERIZED TECHNICAL TIP REPAIR PROGRAM say this is the **"BEST"** Technical Tip program on the market today. Works on ANY IBM compatible computer. **NEW VERSION - works in DOS and WINDOWS. *NO* COPY PROTECTION!!! >>> SPECIAL HOLIDAY Pricing for December<<<. We were the first and still the BEST.>>> FREE Shipping for Prepaid orders (U.S.A) >>>FREE>>> Demo! Have your own tips? Ask about our TIP EXCHANGE policy with >>>FREE>>> Updates! CALL 1-800-215-5081/ 1-516-643-7740. HIGHER INTELLIGENCE SOFTWARE, 60 Farmington Lane, Melville, NY 11747. (((Don't be fooled by other free programs that are not really free & add worthless tips to their program just to advertise a large number & other tip programs >>> that are copy protected with limited installs (now that's a gimmick) >>>.**

*****To All Electronic Servicing & Technology readers; *****
***** HAPPY HOLIDAYS AND A PROSPEROUS NEW YEAR *****
***** from HIGHER INTELLIGENCE SOFTWARE *****

((24,000)) THE LARGEST TECH-TIP PROGRAM IN THE USA. "NEVER BEFORE HAS THERE BEEN AN OFFER LIKE THIS" PROOF IS IN OUR PRODUCT - TEST OUR FULL PROGRAM. (((((((((((((((((((("FREE" "FREE" "FREE"))))))))))))))))))))))))))) We are so sure you will find our computer tech-tip program to be THE BEST OFFERED ANYWHERE, that we will ship our ENTIRE PROGRAM at NO COST TO YOU. Test 1 week, if you are dissatisfied, simply return the program Postage Paid - there is absolutely NO RISK OR COST TO YOU. "OUR TRUST IS IN YOUR SATISFACTION". ***** (Proven to pay for itself within a few repairs) ***** FEATURES INCLUDE: FCC-ID cross reference manual covering VCR's & Microwave, Product Processing Forms. Repairs 1977 thru Nov. 1995, TV, VCR, CD, LD, Projection, Monitor, Stereo, Camcorder, Amplifier, Combo Units, Fax Machine, Satellite, & Microwave. SEMI-ANNUAL NEWSLETTER with Step-By-Step Repairs using today's techniques. NEW product information, industry News and Service Center Assistance. WE ARE THE ONLY TECH-TIP COMPANY that publishes our ENTIRE PROGRAM IN PAPER MANUALS, for service centers who are not computerized. "FREE" format changes computer or paper at each update. One-time membership "PAYS." OUR MEMBERS RECEIVED ((10,000)) NEW TECH-TIPS "FREE" IN OUR NOV. 95 UPDATE. To those Computerized, we offer the MOST ADVANCED DOS or WINDOWS SYSTEM, in which you may Enter or Print Out repairs. Our program covers complex repairs, 165 BRANDS ALL IN ONE CONVENIENT PROGRAM. Repairs are collected daily at three major service centers and sent weekly to our Data Center where each Tech-Tip is gone over completely. Additional Lookup and Cross Reference information is added. This process is how we constantly IMPROVE and INCREASE the program FOR YOUR BENEFIT at each UPDATE. SAVE TIME DIAGNOSING, ORDERING SERVICE MANUALS and RESEARCHING PARTS NUMBERS YOU MAY NOT NEED! GET TO THE BOTTOM LINE "PROFITABILITY," and CALL Ed Erickson, NESDA Member and President of (TV-Man Tech-Tips, Inc.) YOU'LL BE GLAD YOU DID! (800) 474-3588 (407) 750-9922 9-9 EST.

FOR SALE

SERVICE TIPS NOW CONTAINS OVER 17,250 TECHNICAL TIPS. Due to the TREMENDOUS RESPONSE FROM OUR CUSTOMERS, SERVICE TIPS IS NOW ONE OF THE LARGEST AND MOST CURRENT DATABASE'S AVAILABLE TODAY. SERVICE TIPS is organized in ALPHABETICAL ORDER by Brand Model/Chassis & Symptom with 3 lines for Symptom and 8 for Solution. YOU CAN REVISE and EDIT or PRINT any service tip in our database, AND YOU CAN ADD YOUR OWN INFORMATION and it will automatically be alphabetized and sorted. SERVICE TIPS HAS MULTIPLE WAYS TO BACKUP ALL OR PART OF THE DATA. The program contains ACTUAL TECHNICIANS FINDINGS on TV's, Projection TV's, VCR's, Camcorders and other consumer electronic equipment. UNLIKE SOME OTHER PROGRAMS, WE HAVE NO GIMMICKS. ATTENTION ALL 1ST TIME BUYERS - CALL US FOR A SPECIAL BONUS OFFER. SERVICE TIPS is available for \$149.95 plus s&h. For more information CALL US at 1-800-621-8477 (from US & Canada). Demo Disk and Quarterly Updates available. ** DON'T BE LEFT OUT EVEN IF YOU DON'T OWN A COMPUTER ** ELECTRONIC SOFTWARE DEVELOPERS NOW OFFERS 1,926 SERVICE TIPS IN BOOK FORM COVERING COLOR & PROJECTION TV'S, AND VCR'S FOR EMERSON, GOLDSTAR, NEC, SAMSUNG AND ZENITH FOR THE LOW PRICE of \$59.95. TO ORDER Mail Check or Money Order for \$59.95 to: ELECTRONIC SOFTWARE DEVELOPERS INC. 826 SO MAIN ST, SOUTH FARMINGDALE, NY 11735 or call 1-516-221-6403.

FURTHER PRICE REDUCTION. Diehl Mark III \$49, Diehl Mark V Horizontal circuit tester \$169 New. Conductive coating for remote control keypads \$9.99 ppd. WEEC, 2411 Nob Hill Road, Madison, WI 53713. (608)-238-4629, (608)-273-8585.

TV CASE HISTORIES: Booklet with 2,440+ histories. Satisfaction assured. Only \$49 (plus \$3.00 for priority mail). Mike's Repair Service, P.O. Box 217, Aberdeen Proving Ground, MD 21005. Same mailing address 31 years. Send SASE for samples. 410-272-4984, 1-800-2-FIX TVS 11am-9pm.

SERVICE DATA & HARD TO FIND PARTS previously-owned SAMs, manufacturers data, books, FREE catalog. AG Tannenbaum, Box 386, Ambler, PA 19002, (215) 540-8055, fax (215) 540-8327.

ELECTRONICS SOFTWARE DEVELOPERS ANNOUNCES THE RELEASE OF ITS LATEST COMPUTER PROGRAM!!!!!! FCC and MODEL to MODEL CROSS REFERENCE PROGRAM - it will enable you to cross reference 94 Brands with over 3,000 models and over 200 FCC numbers. This NEW program is easy -to- use and all information is in alpha-numerical order and covers VCR's, Camcorders, TV's, and Computer Monitors. Compiled from technicians' information, our easy-to-use format will SAVE YOU TIME AND MONEY as well as ELIMINATING UNNECESSARY PARTS COSTS and DUPLICATE SERVICE LITERATURE. To order send check or money order for \$39.95 plus \$3.50 shipping and handling to Electronic Software Developers Inc., 826 S. Main St., S. Farmingdale, NY 11735 OR for Credit Card Orders CALL 1-800-621-8477. DON'T HAVE A COMPUTER - this information is also available in book form for \$49.95 plus \$3.50 shipping and handling.

FOR SALE

SCORRE TEST EQUIPMENT: LC101, PA81, SC3100, SG80, TVA92, VC93, VG91. Financing available; will sell individually, prices negotiable. **DC&H**, 270 Mikado, Merit Island, FL 32953.

TEST EQUIPMENT BOUGHT & SOLD: OSCILLOSCOPES, ETC. 1-408-738-4206. FAX 1-408-736-6946.

Sencore waveform monitor (scope), model SC61. Complete and in excellent condition. Asking \$1800.00 (Canadian funds). Please phone 604-635-9054 or fax 604-635-4821.

Sencore PR57 isolation transformer, \$350.00. Tektronix 453 scope, \$350.00. B&K 801 capacitor analyzer, \$50.00. B&K 1264 color bar generator, \$75.00. All in excellent condition. Call Paul Farrow, 217-446-1147

IN-CIRCUIT CAPACITOR ESR CHECKER - Find bad caps FAST and RELIABLY with the new Capacitor Wizard in-circuit ESR Tester! Great for monitors, switching power supplies, TVs, etc., only \$179.95, MC/Visa. Independence Electronics Inc. 800-833-1094.

******SONY TUNER CURE****** 1-465-371-11/12 Stop replacing! Repair easily yourself & save! Send \$15.00: **TEK Enterprises**, 212 Marabou Drive, Newark, DE 19702.

FOR SALE

Free 9-516/517 MODULE CURE !!! Stop Relacing! Repair easily yourself. Send business SASE: **TEK Enterprises**, 212 Marabou Drive, Newark, DE 19702.

BUSINESS OPPORTUNITIES

Sunny Florida, Low Crime Community. Well established electronics repair business with building, \$75,000.00. Call 904-799-7194, ask for Len.

TV/VCR/Microwave Repair Business For Sale. Located in growing, thriving, upscale area of Phoenix. Large and loyal customer base. Selling as turn-key operation, other options available. Lovely 2BR home in near-by retirement area also available. Call 602-598-0158, 10-6 M/F, 10-1 Sat (MST).

HELP WANTED

TV/VCR Technician, experienced, good pay, nice atmosphere, growing company. Send resume, P.O. Box 15355, New Bern, NC 28561.

Readers' Exchange

Readers' Exchange is a free service.

The following restrictions apply to Readers' Exchange:

- Only individual readers may use Readers' Exchange, and items must be restricted to those that are ordinarily associated with consumer electronics as a business or hobby. If you're in business to sell the item(s) you want to offer for sale, the appropriate place for your message is in a paid advertisement, not Readers' Exchange.

- Readers' Exchange items must be restricted to no more than three items each for wanted and for sale, and may be no more than approximately four magazine column lines in length (about 20 words).

- All submissions must be typed or printed clearly!

Send your Readers' Exchange submissions to:

Readers' Exchange, Electronic Servicing & Technology, 76 N. Broadway, Hicksville, NY 11801

FOR SALE

Sams Photofacts from 200-2480, 427 folders to be sold as a group only, \$625.00 plus 1/2 of shipping cost. *Contact: Mike's Repair Service, PO Box 217 Aberdeen Proving Ground, MD 21005, 410-272-4984, 11AM-9PM.*

Three hardcover TV servicing books, \$70.00, will sell for \$25.00. Postage included. *Contact: Daniel Seidler, 3721 W 80th Street, Chicago, IL 60652, 312-284-8221.*

Sencore SC61 waveform analyzer, excellent condition, manuals and probes. \$850.00 or best offer plus shipping. *Contact: Major A Meckling, 913-467-8431, 913-467-3921.*

Sams Photofacts. Will sell for \$5.00 each or B/O. *Contact: 805-736-5310.*

Sencore SC61 dual trace wave analyzer. Excellent condition with all probes and manual. Will sell for \$1200.00. *Contact: 409-935-3321.*

Sencore SC61 in original box with all probes and manuals, \$1500.00. Pre-paid postage. *Contact: Frank, 813-546-7060.*

Capacitors, twist-lock electrolytics, tubular coupling, by-pass, high voltage, etc., 12 pages. Free for SASE, 2 stamps. *Contact: Chuck Vaccaro, 706 Booth Lane, Ambler, PA 19002-5014.*

Sencore test equipment, (all models). Please call for a list of all pieces involved. *Contact: Lance, 605-361-6386.*

Sencore VA48, TV-VTR-MATV and video analyzer. Like new condition. \$350.00. *Contact: 408-479-4441*

B&K TV analyst - 1077 134 - sensor field strength meter RCA. Service data 1967-1978. *Contact: Ann Bichanich, 15 1/2 W. Lake Street, Chisholm, MN 55919, 218-254-4421.*

Sencore CVA94, CV93, SC61 with accessories. Like new. *Contact: Jim, 915-235-3520.*

WANTED

Sencore Z-meter at a reasonable price to be used for hobby use. *Contact: William, PO Box 51412, New Orleans, LA 70151-1412, 504-595-1576.*

Realistic tuner/amplifier model 31-3009 (AKA STA2290), need schematic diagram and parts list. Please help. *Contact: Peter Battistoni, 94 Roulin Street, Torrington, CT 06790, or call collect 203-482-8085.*

Deflection yoke for Future Tech model 1918GP. Can anyone cross reference? *Contact: John Phipps, 1412 Navaho Trail, St. Charles, MO 63304.*

Want to buy, JVC VCR service manuals or Zenith service manuals for VCRs made by JVC. *Contact: Truman McGregor, 3601 Jefferson Avenue, Texarkana, AR 75502, 501-773-6488*

Daytron DCT-5002 5 inch ac/dc color TV (no longer available), will pay \$6.00 for a copy of the schematic. *Contact: Scott Cohen, 930 W. Prince Road, Tucson, AZ 85705, 520-888-1316.*

NEW!

ES&T BOOK SHOP



Sound Systems for Your Automobile

The How-to Guide for Audio Systems Selection and Installation
By *Alvis J. Evans and Eric J. Evans*

This book will show you how to plan your car stereo system, choose components and speakers and install and interconnect them to achieve the best sound quality possible. Order# 61046 \$16.95.

IC Cross Reference Book

By *Howard W. Sams & Company*
The IC Cross Reference Book, compiled from manufacturers' data and from the analysis of consumer electronics devices for Photofact service data, will help you find replacements or substitutions for more than 35,000 ICs or modules. Order# 61049 \$19.95.

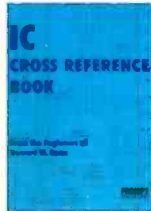

Security Systems for Your Home and Automobile

By *Gordon McComb*

In simple, easy-to-understand language, Security Systems for Your Home and Automobile tells you everything you need to know to select and install a security system with a minimum of tools. Order# 61054 \$16.95.

Speakers for Your Home and Automobile

How to Build a Quality Audio System
By *Gordon McComb, Alvis J. Evans and Eric J. Evans*

Build quality home speaker systems that will complement the sound available from your other components using the instructions in this book.

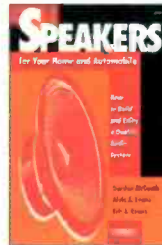

Order# 61025 \$14.95.

Basic Principles of Semiconductors

By *Irving M. Gottlieb*

With its simplified explanations and thorough discussions, Basic Principles of Semiconductors provides everyone, from the hobbyist and student right up to the technician and professional electrician, with an excellent introduction and reference into the principles of semiconductors.



Order# 61066 \$14.95.



Semiconductor Cross Reference Book

By *Howard W. Sams & Company*
From the makers of Photofact service documentation, the Semiconductor Cross Reference Book is the most comprehensive guide to replacement data for all

major types of semiconductors. This volume contains over 475,000 part numbers and other identifying numbers. Order# 61050 \$24.95.

Tube Substitution Guide

Complete Guide to Replacements for Vacuum Tubes and Picture Tubes

By *William Smith and Barry Buchanan*

The Tube Substitution Handbook will help antique radio buffs, consumer electronics technicians and other interested individuals find the right replacement tube when servicing older electronics products.

Order# 61036 \$16.95.



Electronic Control Projects for the Hobbyist and Technician

By *Henry C. Smith and Craig B. Foster*

Electronic Control Projects for the Hobbyist and Technician helps the reader know how and why an electronic circuit works, then applies that knowledge to building practical and dependable projects that solve real, everyday problems.

Order# 61044 \$16.95.



Schematic Diagrams

The Basics of Interpretation and Use
By *J. Richard Johnson*

Step-by-step, Schematic Diagrams shows you how to recognize schematic symbols and their uses and functions in diagrams, and to interpret diagrams so you can design, maintain and repair electronic equipment. Order# 61059 \$16.95.



Industrial Electronics for Technicians

By *J.A. Sam Wilson and Joseph Risse*

Industrial Electronics for Technicians provides an overview of the topics covered in the Industrial Electronics for Technicians CET test, and is also a valuable reference on industrial electronics in general. Order# IET \$16.95.

Advanced Electronic Projects for Your Home and Automobile

By *Stephen Kamichik*

You will gain valuable experience in the field of advanced electronics by learning to build the interesting and useful projects featured in Advanced Electronic Projects. Order# 61065 \$18.95.



Introduction to Microprocessor Theory and Operation

A Self-Study Guide with Experiments
By *J.A. Sam Wilson and Joseph Risse*

Introduction to Microprocessor Theory and Operation takes you into the heart of computerized equipment and reveals how microprocessors work. Order# 61064 \$16.95.



YES! I want to learn from the experts. Rush me my book(s) right away!

Please add \$4 shipping & handling. **FREE** shipping & handling for orders \$50 and over.
Please make your check or money order payable to: Electronic Servicing & Technology.

**Order Toll-Free
1-800-853-9797**

Qty	Order#	Description	Price	Total Price
Shipping/Handling				
(New York Residents add applicable sales tax) Total				

Name _____

Address _____

City _____

State _____

Zip _____

MC/VISA/AMEX/Discover # _____

Form of payment: MC VISA AMEX Discover Check Money Order

Expires _____

Please mail your orders to: **Electronic Servicing & Technology, 76 North Broadway, Hicksville, New York 11801-9962 FAX 516-681-2926**

Tech's Guide To Pricing **NEW**

Sperry Tech's Pricing Guide
 Updated new 6th edition... a framework for setting rates that apply to Hi-Tech products... a formula that guarantees SUCCESS!
 Call Toll Free for details
 1-800-228-4338

Circle (69) on Reply Card

TUBES • TUBES • TUBES
World's Largest Range
 Over 2,000 Types, Domestic & Foreign

UP TO 85% OFF Ask for price list

International Components Corporation
 Toll Free 800-645-9154 • N.Y. State 516-293-1500
 107 Maxess Road, Melville, New York 11747

Circle (60) on Reply Card

GENie® The most fun you can have with your radio on!

No other online service serves the radio hobbyist like GENie's Radio & Electronics RoundTable does. Scanning, shortwave, ham radio, even an online call sign database so you can look up QSL info in an instant! And we have it all at one of the lowest connect time rates of all the major online services

To sign up for GENie with your computer & modem, dial toll free in the U.S. or Canada 1-800-638-8369.

At the U# prompt, type JOINGENIE
 And for a special introductory offer,
 At the key/offer code prompt type BWH528

VCR REPLACEMENT PARTS

VXPO521 Panasonic Idler Orig.	\$2.99ea (10 min)
164113 RCA Idler Original	\$2.99ea (10 min)
NPLY0111GEZZ Idler Original	\$8.95ea
613-022-2534 Sanyo/Fisher Gear	\$2.99ea (10 min)
199347 RCA Replacement Belt Kit	\$1.99ea
VTK-1 Video Tool Kit (15 Pcs) w/case	\$39.95ea
YEM50099 Panasonic Motor	\$8.95ea



POPULAR SEMICONDUCTORS

25D1427	\$1.89ea (10 min)	
25D1555	\$1.99ea	
SOA-3202-3	\$5.95ea	
25C4664	\$3.50ea 10/up \$2.95ea	
STKS63F	\$8.95ea 5/up \$8.50ea	
STK4273	\$9.95ea 5/up \$8.95ea	
STR30130	\$2.95ea Any Quantity!	
STR30135	\$2.95ea Any Quantity!	

POPULAR REPLACEMENT FLYBACKS

2434391 Hitachi	\$24.95ea	
1-439-357-11 Sony	\$24.95ea	
FO014 Sharp	\$19.95ea	
FO015 Sharp	\$19.95ea	
FO016 Sharp	\$19.95ea	
F1588 Sharp	\$27.95ea	
TLF14401F Panasonic	\$29.95ea	
TLF14423F Panasonic	\$29.95ea	
TLF14530 Panasonic	\$24.95ea	

POPULAR REPLACEMENT PARTS

NCS-1 NINTENDO GAME SOCKET	\$7.95ea
340313-5 NAP TUNER	\$34.95ea
4835-1539-7006 NAP SAW FILTER	\$4.95ea
1-228-482-00 SONY FOCUS RESISTOR	\$49.95ea
4835-1163-7005 NAP THERMISTOR	\$3.95ea
KSS-210A ORIGINAL PICKUP HEAD	\$34.50ea

MAT ELECTRONICS

400 Pike Road
 Huntingdon Valley, PA 19006-1610

CALL TOLL FREE 1-800-628-1118
 FAX TOLL FREE 1-800-628-1005

FREE 92 PAGE CATALOG!

Circle (80) on Reply Card

Advertiser's Index

Company	Page Number	Reader Service Number	Advertiser Hotline
Andrews Electronics	13,27	51,52	800/289-0300
B & K Precision	54	77	800/462-9832
Caig Laboratories	67,68	53	800/CAIG-123
Chemtronics	IFC	115	800/645-5244
Computer & Monitor Maintenance	13	54	800/466-4411
Dalbani Corporation	24	55	305/716-1016
Electronic Industrial Association (EIA)	5	116	703/909-7656
Electronics Technicians Association	10	56	317/653-4301
Electronix Corporation	30	57	800/223-3205
Fluke Corporation	BC	110	800/44-FLUKE
GENie Radio & Elec. Roundtable	72		800/638-8369
Herman Electronics	46	58	800/938-4376
ITT Pomona	53	59	800/241-2060
ISCET	30		817/921-9101
International Components Corp.	72	60	800/645-9154
Jensen Tools	21	61	800/426-1194
LG Precision	48	62	310/404-0101
MAT Electronics	72	80	800/628-1118
MCM Electronics	44	63	800/543-4330
NESDA	67		800/433-5557
PTS Electronics	9	64	800/844-7871
Parts Express	10	65	800/338-0531
QB Products	57	66	800/323-6856
RNJ Electronics	50	67	800/645-5833
Sencore	IBC	1	800/SENCORE
Specialized Products	51	68	800/439-4250
Sperry Tech	72	69	800/228-4338
Tentel	52	70	800/538-6894
Wavetek	3	71	800/854-2708

We'd like to see your company listed here too. Call Diane Klusner at 516/681-2922 to work out an advertising program tailored to suit your needs.

ELECTRONIC

SALES OFFICE

PHONE (516) 681-2922

FAX (516) 681-2926

ELECTRONIC

Special Report:
New consumer electronics technology

Tech Training™

by SENCORE

“Sharing Your Vision For Success”



Technical know-how is a service technician's most important tool. Today more than ever, a solid functional understanding, combined with proven effective troubleshooting techniques is essential to your success. But where do you get solid, well-rounded training? How do you learn good troubleshooting skills? To meet the growing demand for solid, fundamental, practical training, Sencore introduces Tech Training - training by technicians... for technicians.

Computer Monitor Servicing Course - TC100

(Approved for CEU credit)

This hands-on self study course teaches you how to efficiently test and troubleshoot as you work through the activities and self tests. You'll learn:

- How to quickly determine monitor types
- How to make all monitors look alike from the SMPS to the CRT
- What video patterns to use to accurately identify failures



Computer Monitor Servicing Class - TC100T

(Approved for CEU credit)

This 3 1/2 day class provides hands-on experience on actual chassis. You'll learn how computer monitors work, typical circuit operation, how to make adjustments, and lots of practical troubleshooting.

Call for locations and dates.

Understanding Television Horizontal Stages - TV300

The horizontal stages are the most complex, hardest working, and probably the highest failure part of a television receiver. Knowing how these stages work, how they fail, and how they interact with other circuits will help you conquer these difficult servicing problems. This training package includes a self-study workbook and a 45 minute video.



Tech Choice Technical Troubleshooting Demonstrations

Do you need a quick servicing refresher? No matter how you service, you'll take home valuable tips that you'll put into practice immediately. Choose from these practical demonstrations:

- Computer Monitor Troubleshooting
- Profitable TV Troubleshooting
- Simplified VCR Servicing
- Camera/Camcorder Testing & Troubleshooting

Check the city listing below for upcoming Tech Training locations:

Albuquerque • Atlanta • Baltimore • Birmingham (AL) • Boston • Buffalo • Calgary • Chicago • Cincinnati • Cleveland • Dallas • Detroit • Edmonton • El Paso • Houston
Indianapolis • Kansas City • Knoxville (TN) • Los Angeles • Miami • New York City • Oklahoma City • Philadelphia • Phoenix • Pittsburgh • Raleigh (NC) • Reno
San Diego • Seattle • Sioux Falls • Tampa • Toronto • Vancouver • (Tentative list. Not all Tech Training classes will be held in all locations. Call for details.)

Circle (1) on Reply Card

Call 1-800-SENCORE(736-2673)

Sencore, 3200 Sencore Drive, Sioux Falls, SD 57107 • Phone: (605) 339-0100 • FAX (605) 339-0317

6196

FLUKE®

A scope that does both analog and digital? I'd like a closer look.

Sometimes a digitized waveform

isn't enough.

So, I must check

the analog waveform.

CombiScope gives me

both views

at the touch of a button.

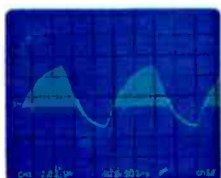
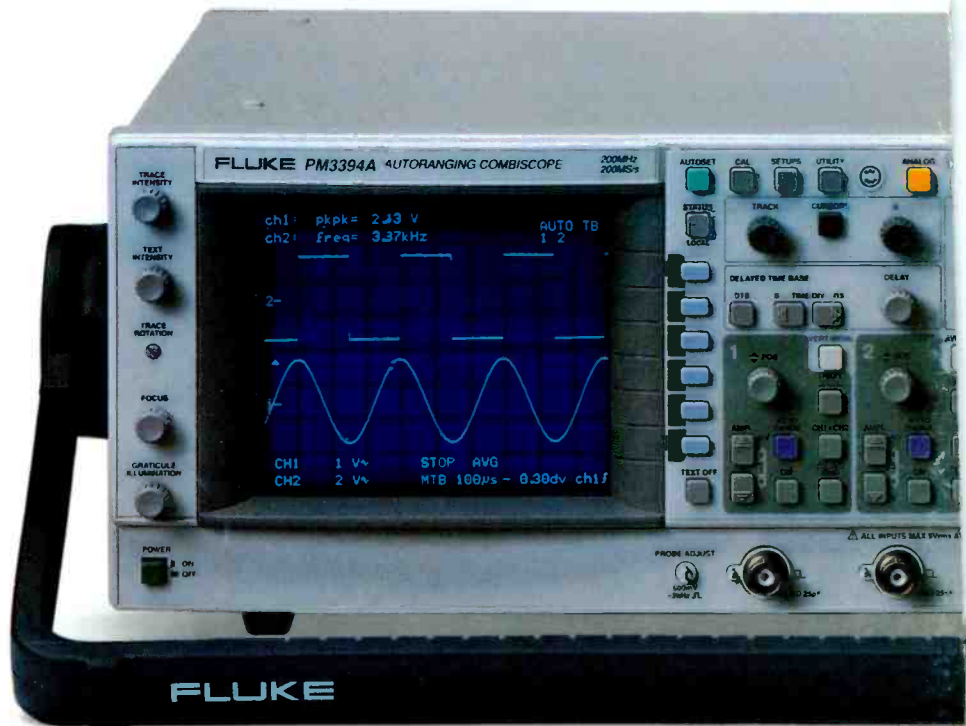

Analog mode

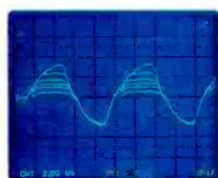

Digital mode

It's your responsibility. But each new problem has hidden tricks, so you check them and re-check them.

The Fluke CombiScope™ is the most powerful scope with DSO and analog modes that show the whole picture. It's packed with the features a professional needs. The exclusive Autoranging feature lets you move from test point to test point while the scope automatically adjusts itself. Eighteen automated voltage, delay and time measurements

are standard. Seven versatile models make sure you're covered. And FlukeView™ software for Windows® adds PC power to your CombiScope.

When the pressure is on and the problems are tough, a closer look can mean getting closer to the solution. Take a look at the Fluke CombiScope today.



Don't assume anything. Call Fluke at 1-800-44-FLUKE.