

THE PROFESSIONAL MAGAZINE FOR ELECTRONICS AND COMPUTER SERVICING

ELECTRONICTM

Servicing & Technology

June 1997

VCR servicing

Setting up a service bench

Test equipment update



Sharp Color Television
Model No.
25H-M100

U.S. \$3.50

06>



7 25274 86667 0

Overwhelming

Force



Repair over
LOAD



the future of electronics servicing

Increase your productivity—and decrease the backlog of unrepaired TVs and VCRs sitting around your shop—with FORCE. It's the easy-to-use, innovative computer system that gives you instant access to diagrams, components, circuits, all known faults, parts information, troubleshooting tips and more! In fact, with FORCE the only thing that will be overwhelming is your productivity.

For complete information call **(423)475-0393** today.
401 E. Old Andrew Johnson Highway, P.O. Box 555, Jefferson City, TN 37760

Let's make things better.



PHILIPS

Circle (117) on Reply Card

ELECTRONIC

Servicing & Technology

Volume 17, No. 6 June 1997

Contents

FEATURES

10 VCR servicing: Taking the mystery out of video head replacement

By Philip M. Zorian

Even considering the low cost of VCRs in today's market, VCR head drum replacement is still an economical repair.

13 Setting up a service bench

By The ES&T Staff

A little attention to providing a comfortable, well lighted environment for servicing technicians is almost certain to result in improvements in morale and efficiency.

16 An IHVT problem

By Roger D. Redden

This article will help servicers to troubleshoot and correct IHVT problems.

18 Test equipment update: Repairing computer monitors

By Wade H. Lckey

This article consists of monitor theory and suggestions about their repair, along with case histories.

24 Servicing television tuner problems

By Bob Rose

Replacing a defective television tuner often means a hefty repair estimate for your customer. This article

explains how a servicer can cut the cost of repair by fixing the tuner himself.

46 Identifying circuit components

By Victor Meeldijk

This article is a list to help identify components from prefixes and logos. It also contains cross references to enable the user to find companies after mergers, acquisitions and name changes.



page 13

DEPARTMENTS

4 Editorial

8 News

29 Profax

42 Calendar of Events

44 Literature

54 What Do You Know About Electronics?

The problem and the detailed solution.

55 Test Your Electronics Knowledge

56 Products

61 Books

62 Classified/Reader's Exchange

64 Advertisers' Index



page 18

ON THE COVER

As consumer electronics continues to change and grow, the array of test equipment requires to test the products also changes and grows. Personal computers and peripherals such as monitors, printers, etc., represent one class of device for which new test equipment has been introduced and continues to be introduced. (Photo courtesy Sencore)

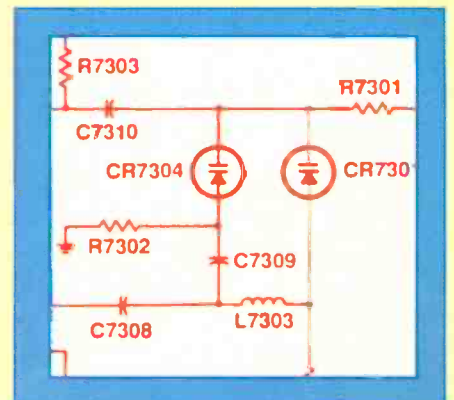

page 24

WANTED

Your Universal Replacement Part Business

THE SK SERIES GANG

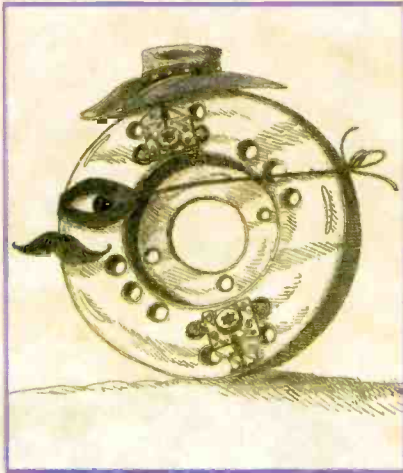

"CURLEY"

Video Head



"TEX"

Laser Pickup



"SLIM"

Flyback Transformer

\$250
per unit
REWARD

All you have to do is purchase any SK Series video head, laser pickup, or flyback between April 1 and June 30, 1997, fill out a redemption form and send it along with the numbered box top and your invoice. Simple as that. Some restrictions apply. Void where prohibited by law. See your participating authorized Thomson Consumer Electronics distributor for details.

See Your Participating Authorized
Thomson Consumer Electronics
Distributor For Details.

Circle (113) on Reply Card



Visit Your Local Participating Thomson Consumer Electronics Distributors For More Information

Arizona

Arizona Wholesale Supply Co Phoenix

California

Jack C Arbuckle Co Bakersfield
Jack C Arbuckle Co Fresno
Martin Distributing Co Huntington Pk
Martin Distributing Co Los Angeles
Inland Electronics Suppliers Modesto
Inland Electronics Suppliers N Highlands
Cass Electronics Inc Oakland
Chuck Hurley's Electronics Inc Sacramento
Inland Electronics Suppliers San Jose
Andrews Electronics Inc Santa Clarita

Colorado

Fistell's Electronic Denver

Connecticut

Signal Electronic Center Inc West Hartford

Florida

Herman Electronics Miami
Tritronics Inc Miami
Vance Baldwin Inc Miami
Vance Baldwin Inc Pompano Beach
Fouraker Electronics Inc Tallahassee
Dow Electronics Inc Tampa
RES Marketing Inc Tampa
Vance Baldwin Inc Tampa

Georgia

Fouraker Electronics Inc Macon
Dow Electronics Inc Norcross
Wholesale Industrial Elect Inc Norcross
Fouraker Electronics Inc Valdosta

Illinois

Union Electronics Inc Beecher
Deltronics Distributing Co Belleville
Fox International Inc Chicago
North Central Elect Supply Chicago
Laco Electronics Inc Decatur
Tri-State Electronic Corp. Mount Prospect
Laco Electronics Inc Mt Vernon

Indiana

ESP/Electronic Service Parts Indianapolis

Iowa

Ness Electronics, Inc Des Moines

Kansas

G M Popkey Co Lenexa

Kentucky

Randolph Hale & Meredith Inc Bowling Green
Randolph & Warren Louisville

Louisiana

Pelican Electronic Supplies Inc Houma
Pelican Electronic Supplies Inc Metairie
Southern Electronics Inc Shreveport

Massachusetts

E A Ross Co Inc Fall River
Nash Electronic Supply Inc Leominster
Tee-Vee Supply Company Inc Medford
Electronic Distributors Corp North Quincy
Signal Electronic Center Inc Springfield

Maryland

Tritronics Inc Abingdon
Mark Electronics Inc Beltsville

Michigan

Bursma Electronic Dist Inc Bay City
Bursma Electronic Dist Inc Benton Harbor
Electronic Parts Specialists Inc Flint
Bursma Electronic Dist Inc Grand Rapids
Remcor Electronics Inc Oak Park
Bursma Electronic Dist Inc Traverse City
Bursma Electronic Dist Inc Warren

Minnesota

Ness Electronics Inc Minneapolis

Mississippi

E A Helwick Electronics Inc Gulfport

Missouri

Cititronix Inc St Louis
Deltronics Distributing Co St Louis

North Dakota

S/S Electronics Inc Fargo

New Jersey

Penn-Jersey Electronics Phillipsburg
Panson Electronics Pine Brook

New York

Standard Electronics Inc Amherst
Jayso Electronics Corp Bronx
Mill Electronics Supply Co Brooklyn
Eiger Electronics Inc Deer Park
Fox International Inc Farmingdale

Ohio

Fox International Ltd Inc Bedford Hts
Excel Distributing Inc Cincinnati
Superior Elect Parts Co., Inc Parma

Oregon

Pringle Electronics Dist Inc Milwaukie
Double O Electronics Dist Inc Portland

Pennsylvania

Cumberland Electronics Inc Harrisburg
Clearfield Electronic Supp Co Hyde
Cumberland Electronics Inc Lancaster
H B F Electronics Inc Philadelphia
Jem Electronic Distributors Inc Philadelphia
CRS Electronics Pittsburgh
Cumberland Electronics Inc York

Rhode Island

Jabbour Electronic Supplies Inc Pawtucket

South Carolina

Wholesale Industrial Elect Inc Charleston
Wholesale Industrial Elect Inc Columbia
Wholesale Industrial Elect Inc Greenville
Harley's Wholesale Electronics Spartanburg

Tennessee

Shields Electronics Supply Inc Bristol
Shields Electronics Supply Inc Chattanooga
Townsend Electronic Supply Jackson
Shields Electronics Supply Inc Knoxville
Electrotex Tennessee Inc Memphis

Texas

Nunn Electric Supply Corp Amarillo
Electrotex Inc Austin Austin
Electrotex Inc Beaumont Beaumont
Electrotex Inc Corpus Christi Corpus Christi
Electrotex Inc Dallas Dallas
Interstate Electric Co Dallas
Electrotex Inc Richmond Houston
Nunn Electric Supply Corp Lubbock
Fox International Ltd Inc Richardson
Electrotex Inc San Antonio San Antonio

Utah

Ballard Supply Corporation Salt Lake City

Washington

Pringle Electronic Dist Inc Everett
Pringle Electronic Dist Inc Olympia
Pringle Electronic Dist Inc Spokane

Wisconsin

G M Popkey Co Green Bay
G M Popkey Co New Berlin
G M Popkey Co Wausau
Ness Electronics Inc Milwaukee



Electronics and mathematics

It seems fair to conclude that the average individual tends to be math phobic. Mathematics is hard. And it's unforgiving. In many other disciplines there can be more than one correct answer. Or you might come up with an answer that's close enough. In math, you either get the right answer or you don't.

So most of us tend to avoid dealing with math whenever we can. After all, if you get involved in some complex calculation, even if you're really good at math, you can wind up tripping over your own feet, figuratively speaking.

Unfortunately, certain professions demand that practitioners be familiar with math and know how to use it. Take for example a carpenter. Every time a carpenter builds something, he has to measure carefully, set angles, make allowances for material thickness. A carpenter might not like doing the math, but if he likes doing the carpentry, he had better learn to do the math.

Or how about a business man. Many of you know what that's like. You have to know how to put together a profit and loss statement, adjust profit margins, establish pricing. There's a lot of math involved in running a business.

Electronics servicing is one of those professions where, like it or not, you will at times have to perform some mathematical calculations. A technician may love the idea of electronics, live for finding out why that TV set failed and figuring out how to put it back into working condition, and yet hate everything to do with math. Nevertheless, from time to time he will probably have to perform some mathematical calculations.

For example the old standby oscilloscope has a screen that's divided into time on the horizontal (x) axis, and amplitude on the vertical (y) axis. Unfortunately, on an oscilloscope face, everything's relative. It's possible to get a general idea of the shape of the wave just by looking at it, but if you want to know anything quantitative about the signal, you have to per-

form some calculations to get the information you need.

Let's say there's a sine wave on the screen. In order for the technician to determine the actual peak to peak amplitude he has to count the number of graticule divisions and multiply by the scale factor of the vertical multiplier knob, plus any multiplier built into the probe. To determine frequency of the signal being measured, he has to count graticule divisions for one full cycle and multiply by the scale factor on the horizontal multiplier knob to determine the period of the signal, then he has to divide that value into one to calculate the frequency.

But sometimes math is required to properly understand a concept. And having a true understanding of a concept sometimes requires doing the math. Root-mean-square (rms), for example, is a strictly mathematical concept. Rms must be used in order to determine the effective value of any repetitive waveform that is symmetrical about the horizontal axis. The average value of such a wave is zero because just as much of it is above the horizontal as is below the horizontal axis.

In order to determine the effective value of such a wave, we have to first square the equation that describes the waveform. That makes all of the points on the waveform positive. Then we take the average value (mean) of the squared waveform, then we take the square root of the average. Thus we have determined the root of the mean of the square. That's a lot of math.

But mathematical concepts abound in electronics. The charging of a capacitor, or the decay of voltage across an inductor when a dc source is placed across it, or the linear relationship between the current through a resistor and the voltage across it isn't really understood until it's understood in a mathematical way. It is, simply put, a mathematical relationship.

We've been pretty sure that a lot of readers need and use this type of math in their daily servicing, so we've been publishing articles (notably in "What Do You

Know About Electronics") that discuss mathematical concepts. Recently we decided to test that assumption.

In the April issue we included a survey questionnaire that asked readers about their involvement with mathematics. The results are still coming in, but the initial response shows that the respondents in general use math to help them in servicing. Moreover, many of them read the math-related articles in this magazine and find them useful.

One question asked, in effect, "If you have ever used math to help in servicing, please tell us about it." Here are some of the responses we received.

- Calculate current drain on the output of an audio amplifier. Calculate the current drain on motors.
- Use Ohm's Law to check current draw on defective circuits.
- Math is used every time you use a meter on a resistor. You measure voltage drop. In the case of a transistor, do you have 0.7V difference between the emitter and base. Math is second nature. You don't even realize you're using Kirchhoff's Law or Ohm's law.
- There are two types of doctors; those who cut first, then have to cut again; and those who are careful and only have to cut once. In the case of electronics technicians even simple math will save you from errors that you will have to correct.

There were a lot more similar responses, but this gives the idea.

Math can be difficult, demanding and frustrating. But it definitely helps in understanding electronics concepts, and sometimes can improve the efficiency of actual servicing procedures.

The more practice we get with math, the more proficient we become. For that reason, and because our readers in general find the math articles in **ES&T** to be useful, we will continue to publish them from time to time. And, hey, we at **ES&T** need the practice too.

Nile Conrad Penner

QUALITY or *Low Cost*

Get Both From Leader New DC Power Supplies

DIGITAL
DISPLAY

110V 3A



75V 5A



60V 3A



35V 10A



18V 20A



18V 10A

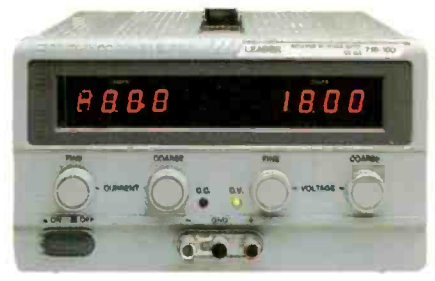

30V 3A



18V 5A



18V 3A



Call toll-free

1 800 645-5104

In NY State

516 231-6900

LEADER
FOR PROFESSIONALS WHO KNOW
THE DIFFERENCE

Leader Instruments Corporation, 380 Oser Avenue, Hauppauge, New York 11788
Regional Offices: Chicago, Dallas, Los Angeles, Atlanta. In Canada call Omnitronix Ltd., 905 828-6221

Circle (101) For Product Information

Circle (102) For Product Information & Demonstration

Cordless phone sales top 20 million in record-setting 1996

The Consumer Electronics Manufacturers Association (CEMA) reported today that sales of cordless telephones surpassed the 20 million unit level in 1996 for the first time ever, representing the eleventh straight year of record sales. Sales to dealers of corded phones and telephone answering devices (TADs) were also up slightly in the year-to-date.

A robust holiday season for cordless phones—amounting to a 10 percent jump in unit sales—helped spur cordless models to a 5.4 percent year-to-date increase. Feature phones made up nearly 60 percent of the sales total.

“We are seeing a rapid acceptance of cordless phones into American households,” said a CEMA spokesman. “Two years ago, cordless models could be found in just over half (52 percent) of U.S. households, and now that number is already up to 66 percent.”

After jumping by nearly 2 million units in 1995, corded telephones sales remained steady in 1996 with just over 26 million units sold—a 1 percent increase. Sales of corded feature models increased 11 percent.

Digital was delightful for the telephone answering device (TAD) market in 1996. Unit sales of fully digital models leapt over 50 percent, while TADs overall showed a small gain. The share of U.S. households with an answering device climbed 5 percent during the year, from 60 percent to 65 percent.

Despite a strong fourth quarter, shipments of stand-alone fax machines continued to decline in 1996 due to the proliferation of products such as fax modems and multi-function machines.

Satellite installer certification recognizes small-dish-only technicians

SDA's Certified Satellite Installer examination and registration program, initiated in 1991, has been reorganized to provide recognition to installers who are engaged in the small-dish end of the profession only.

Phil Rosales, CSI, Chairman of SDA (The Satellite Dealers Association), said:

“The new RSDI (Registered Small Dish Installer) program allows those newcomers to the TVRO business to receive credentials as professionals without being required to learn C/Ku band technology.”

Dick Glass, CETsr, who manages ETA and SDA's certification and testing programs, says: “our office has received an increasing number of communications from industry people who feel the new breed of small dish installers and servicers of small dish systems will need to use professional installation techniques to keep the satellite business from suffering any more ‘black eyes’. There is a growing need for both small and large-dish workers to be able to interface the satellite systems properly with a variety of home electronics products and to be able to install MDU - multiple dwelling units - systems, now that the DTH manufacturers are targeting that market”.

The 100-question Certified Satellite Installer (CSI) examination has been upgraded to include the small dish technology and both the CSI and RSDI exams now include requirements for knowledge of RF distribution techniques and devices.

For information call SDA at: 765-653-4301 or 765-653-8626 (Fax), or e-mail: eta@indy.testnet.com.

CEMA to sponsor TV/PC interface standard meeting

The Consumer Electronics Manufacturers Association (CEMA) has announced that it is sponsoring the first major effort to develop an industry standard for the interface between large screen televisions and personal computers. It is these standards that ensure product compatibility which makes these electronics more consumer-friendly.

“our members are eager to develop an interface standard for the television and the computer. With consumers enjoying more electronics entertainment and information opportunities than ever before, we want to be certain there is a simple and standardized method to deliver that product” explained Gary Shapiro, president of CEMA. “To accomplish this, CEMA will work to develop product interface standards that will provide solutions to the

technical inter-operability dilemmas facing television and personal computer manufacturers.”

CEMA traditionally works with member companies and interested parties to develop technical standards for the consumer electronics industry. CEMA historically has had great success in helping to develop well-known standards, such as stereo television and the RS-232 port. CEMA offers manufacturers a variety of opportunities to undertake these initiatives and minimize confusion about the technical requirements of various consumer electronics products.

The first meeting of the TV/PC standard committee was scheduled in Indianapolis, IN on Wednesday April 30, at the offices of Thomson Consumer Electronics, open to all interested parties.

Mr. Jack Nick, Vice President of Accessories and Components Business at Thomson, stated that, “This is an extremely important and historic meeting because for the first time, consumer electronics manufacturers, including television and personal computer makers, will be sitting down together to develop a series of technical specifications that will provide manufacturers a common basis by which their products will work together. This is yet another example of how the consumer electronics and computer manufacturing industry works together, and in a joint effort, will develop standards that will ultimately benefit the consumer.”

CEMA is a sector of the Electronic Industries Association (EIA), the 73-year-old Arlington, Virginia-based trade association representing all facets of electronics manufacturing.

Video products post solid sales increases; TV/VCR combos and camcorders set the pace

Sales of home video products enjoyed robust growth in virtually all categories in February, 1997, the Consumer Electronics Manufacturers Association (CEMA) said. Manufacturers sold nearly 3 million pieces of consumer video equipment to U.S. dealers in February, a 15 percent expansion as compared with

(Continued on page 58)

Electronic Servicing & Technology is edited for servicing professionals who service consumer electronics equipment. This includes service technicians, field service personnel and avid servicing enthusiasts who repair and maintain audio, video, computer and other consumer electronics equipment.

EDITORIAL

Nils Conrad Persson, *Editor*
(Internet e-mail: cpersedit@aol.com)
Kirstie A. Wickham, *Associate Editor*
(Internet e-mail: kirstieest@aol.com)
Richard S. Moseson, NW2L, *On-Line Coordinator*

CONSULTING EDITORS

Homer L. Davidson, *TV Servicing Consultant*
Victor Meeldijk, *Components Consultant*
John E. Shepler, *Audio Consultant*
Sam Wilson, *Electronics Theory Consultant*

PRODUCTION

Elizabeth Ryan, *Art Director*
Barbara McGowan, *Associate Art Director*
Edmond Pesonen, *Electronic Composition Mgr.*
Dorothy Kehrwieler, *Production Manager*
Emily Kreutz, *Assistant Production Manager*
Pat Le Blanc, *Phototypographer*

BUSINESS

Richard A. Ross, *Publisher*
Diane G. Klusner, *Associate Publisher*
(Internet e-mail: dianekest@aol.com)
Frank V. Fuzia, *Controller*
Catherine Ross, *Circulation Manager*
Melissa Nitschke, *Operations Manager*
Jean Sawchuk, *Data Processing*
Denise Pyne, *Customer Service*

SALES OFFICE

Electronic Servicing & Technology
76 N. Broadway, Hicksville, NY 11801
516-681-2922; FAX 516-681-2926

Diane G. Klusner, *Director of Advertising*
Emily Kreutz, *Sales Assistant*

EDITORIAL CORRESPONDENCE:

P.O. Box 12487
Overland Park, KS 66212
913-492-4857



Electronic Servicing & Technology (ISSN 0278-9922) is published 12 times a year by CQ Communications, Inc. 76 N. Broadway, Hicksville, NY 11801. Telephone (516) 681-2922. Periodical class postage paid at Hicksville, NY and additional offices. Subscription prices (payable in US dollars only): Domestic—one year \$26.95, two years \$49.95. Canadian—one year \$36.95, two years \$69.95. Foreign Air Post—one year \$44.95, two years \$85.95. Entire contents copyright 1997 by CQ Communications, Inc. Electronic Servicing & Technology or CQ Communications, Inc. assumes no responsibility for unsolicited manuscripts. Allow six weeks for delivery of first issue and for change of address. Printed in the United States of America.

Postmaster: Please send change of address notice to Electronic Servicing & Technology, 76 N. Broadway, Hicksville, NY 11801.

CQ Communications, Inc. is publisher of CQ The Radio Amateur's Journal, Popular Communications, CQ Radio Amateur (Spanish CQ), CQ VHF, CQ Contest, and Electronic Servicing & Technology.

Wavetek. The Way Value Is Measured.

For the best values in digital multimeters everyone is turning to the Wavetek XT Series. Each of these full-function DMMs measures voltage, current, resistance, and also a set of additional electrical or electronic properties you work with every day. Inductance. Capacitance. Frequency.

Temperature. There is an XT Series DMM right for you. With oversized character displays, these DMMs are as easy to read as they are to use. All have fully fused current inputs and input warning beepers to protect you and the meter. Each comes with safety test

leads and are approved to IEC1010-1 safety standards.

Our commitment to reliability and high quality is backed by the industry's only "No Hassle" warranty program. If your XT Series meter requires warranty service, your local dealer replaces it immediately. Call today for full details and the names of your local Wavetek distributors. You'll find that when it comes to Wavetek performance and price, nothing else measures up.

Wavetek Corporation
9145 Balboa Avenue, San Diego, CA 92123
(800) 854-2708

WAVETEK
Circle (97) on Reply Card



27XT

A unique combination of DMM and component checking in a single meter.

- Inductance
- Capacitance
- Logic
- Frequency

Accessories include current clamps, RF & HV probes, temperature converters, holsters, boots and carrying cases.

23XT

Electronic and electrical test functions for general duty and HVAC/R.

- VAC Safety Tester™
- Temperature
- Transistor
- Logic

25XT

A full C-meter in a DMM, and more! Ideal for AV, cell-phone & antenna matching inspection.

- Full Capacitance 0.1pF to 20nF
- Capacitance Zeroing & Test Slots

28XT

A thermometer + DMM for HVAC/R, building or plant maintenance.

- Temperature
- Capacitance
- Frequency
- Mass-Hold

85XT

A precision True-RMS reading DMM, ideal for copiers.

- 4 1/2 digit
- Accuracy
- True-RMS
- Frequency
- Duty Cycle

LCR55

Full-function LCR, also test features for "buy-by" in a component checker.

- Inductance
- Capacitance
- Resistance
- Transistor
- Dual Diode



VCR servicing: Taking the mystery out of video head replacement

By Philip M. Zorian

VCR video heads are fragile and prone to failure. Videotape oxides and tape debris can easily clog up the infinitesimal video head gap (only 38 microns wide), resulting in either a total loss of picture or distortion. Cleaning the video heads will usually remedy this problem. Eventually, however, the video heads either wear out or become damaged to the point where a cleaning has no effect, and the only remedy is a video head replacement.

Video heads (Figure 1) are small electromagnets that are mounted with great precision onto the upper video drum. Whenever video heads require replacement, the entire upper drum must be replaced. This is not a difficult procedure, but properly identifying a defect in the video heads can be a challenge. The consequence of installing new video heads with no resultant improvement in picture quality is a loss of both time and money.

The first part of this article explains how to identify defective video heads, taking most of the risk out of this repair. The second part will guide you through the replacement of the video heads.

The number of video heads

Some VCR models have two video heads while some have four or six. A common misconception is that more video heads will deliver better picture quality. The fact is, there are never more than two heads being used during the normal playback of video. The other video heads are used to improve picture quality during pause, fast forward search, special effects such as slow motion, and slower tape speeds. It is important to understand this when identifying video head defects.

Since the audio heads are separate from the video heads on most models, you will typically find that, although the video is defective, the audio is normal. On VCRs

with hi-fi audio, however, the audio is recorded and played back using the same heads that record and play back the video.

Diagnosing the problem

When the video image quality is defective or when the video is completely absent but the audio is normal, suspect the video heads. The following symptoms are typical of defective video heads:

- band of static at top or bottom of screen,
- white trailing horizontal lines off right side of image,
- snowy picture,
- loss of detail and out of focus,
- partial picture,
- total picture loss,
- excessive drop-out,
- unstable image,
- one third of an image.

Distorted video with distinct horizontal lines present in the white or high frequency parts of the picture are indicative of excessive head wear, since these areas are the hardest for the video head to reproduce. Total picture loss is a difficult symptom to diagnose, since it offers very little video information. The newer VCRs will display a blue screen instead of static if the video heads are not working properly. If there is an image on the bottom third of the screen only, one of the video heads is most likely defective or clogged.

Visual inspection

When you suspect that the heads of a VCR may be defective, start by opening the cover and spinning the video drum with your hand to be sure it spins freely. Check the two Philips screws that hold the head drum down for tightness and be sure the video drum is firmly in place. Look for any obvious damage to the drum itself. Also check the guideposts since they can occasionally break off. Make sure the tension band is in place around the base of the supply reel. Are both reels able to spin freely?

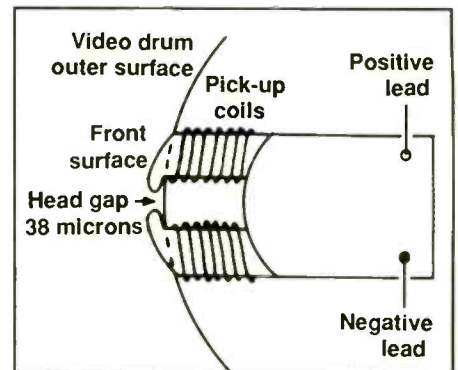

Figure 1. Video heads are small electromagnets that are mounted with great precision onto the upper video drum.

Insert a tape and press play to verify that the videotape is actually making contact with the video drum. Check the belts for slippage and the pinch roller for excessive wear. Belts are often used to drive the capstan, and a loose belt here will result in erratic tape speed. All belts are checked by holding one pulley and gently trying to turn the other to see if it slips.

Use a small (20X) magnifying glass under good light to determine if the video heads are physically cracked or chipped. Get a close look at a good video head to know what you are looking for.

Cleaning the video heads.

Clean the video heads. If this has no effect on the symptom, you can rule out the possibility that the heads are simply clogged. If this clears up the problem completely, your work is done. If you observe some slight improvement in the quality of the image, clean the heads a few more times using a solvent that is approved by the manufacturer for the purpose. You are dealing with video heads that are excessively clogged. Clean the tracking head as well.

Check the pause function and the outputs

Check the pause function for information. This is helpful when dealing with a total loss of picture. A four or six head

Zorian is director of the audio/video department at the School for International Training in Brattleborough, VT and is the owner of Phil's VCR Repair.

VCR may produce a picture in pause mode revealing two important things: the playback heads are defective, but all other VCR circuits are good. This will not happen with a two head VCR, since the same heads are used for both the playback and pause functions.

VCRs output video in two different ways: RF Out and Video Out. Verify that the same symptom is occurring on both video outputs. A clean video image from either one of these outputs will rule out a defect in the video heads. If you observe the exact same symptom on both outputs, the video heads are still suspect.

Check for connection problems

Check for a cold solder joint or loose connection on the top of the video drum. At this point you should check the video heads for continuity by removing one of the leads. An open circuit is enough evidence to indicate a defective head. There is a video head tester available on the market for about \$50.00. But I have found that the test results from this tool are not conclusive, and the tester is unable to test all video heads on all VCR models.

Start by checking the simple things

first. You are trying to identify, beyond a reasonable doubt, a defect in the video heads. The strategy is to rule out all other possibilities that might cause similar symptoms. At this point there are four more things to check: tape speed, tape tension, guidepost alignment and speed of rotation of the video drum.

Tape speed

Unless the videotape is moving past the video heads at a constant rate of 1.31 inches per second, the video heads cannot track properly, and the video quality will suffer accordingly. Since the quality of the Audio is also affected by the tape speed, use the Audio as a way of detecting this problem by listening to a videotape with a tone recorded at 1,000Hz.

The following defects in the speed of the tape are easy to detect: too fast, too slow, wow and flutter. Be certain that you know what this tone should sound like by first playing it on a good VCR.

If you don't have a videotape with a tone recorded on it, use a tape with music you are familiar with. The ideal sound for this purpose is a single instrument or a voice. If you are able to detect a problem

with the tape speed, then incorrect tape speed is the most probable cause of the video problem, and the video heads should not be replaced.

Tape tension

Tape tension that is too low will result in a total picture loss. If the tape tension is too high, you will see symptoms that look similar to those caused by defective video heads. The first mechanism the videotape encounters as it leaves the videocassette is the tape tension guide. While monitoring the video with a known good tape, move this tension guide very slowly to the left, (to tighten) no more than 1/4 inch. Then move it slowly to the right (to loosen), no more than 1/4 inch. If you observe an improvement in the image, improper tape tension may be the cause of the video problem. This should be done on a good VCR to get a sense of the effect that tape tension can have on a VCR's ability to faithfully reproduce a clean and stable picture on the screen.

Guidepost height

When the videotape is fully loaded, it is wrapped around 3/4 of the video drum

DALBANI

The Ultimate Savings Source

HITACHI **RCA** **SONY**
DALCO **SANYO**
SONY **FLUKE**
DAEWOO **DAEWOO** **DAEWOO**
SAMSUNG **Toshiba** **Allegro**
SOLIDEX **3M** **Zenith**
JBRO **SONY** **DAEWOO**
EVEREADY **PIYRAMID**
DURACELL **DAEWOO** **DAEWOO**
ENERGIZER **DAEWOO** **DAEWOO**
EMERSON **MAGNA/OX** **WAL**
HAP
PARALISE
JBL **DAEWOO**
DAEWOO
DAEWOO
UCANDO
Xcelite **Weller**
DAEWOO **DAEWOO**

CATALOG
17

CALL TOLL FREE
1-800-325-2264

\$3.95

FREE 248 PAGE CATALOG

A Picture is Worth
30,000 Items

4225 N. W. 72nd Ave.
Miami, Florida 33166
TEL : (305) 716-1016
FAX : (305) 594-6588

EXTECH

True RMS Multimeters

Voltage, Current, Resistance, Frequency, Temperature, Capacitance, Conductance, dBm, Duty Cycle, Pulse Width

Model 380288

Model 380285

Model 380282

- Up to 40,000 count LCD display with bargraph
- Models with 0.06% basic DCV accuracy and 1µV or 10nA resolution
- Max/Min, Auto or manual ranging
- Type K temperature measurements
- Optional RS-232 interface/software

Phone, Fax or E-mail today for brochure and name of local stocking distributor

EXTECH ISO9001 CERTIFIED
INSTRUMENTS

335 Bear Hill Rd, Waltham MA 02154
Tel: (617) 890-7440 • Fax: (617) 890-7464
Website: <http://www.extech.com>

Circle (61) on Reply Card

Circle (63) on Reply Card

and held in place by the guideposts. They must hold the videotape at a precise height as it moves around the drum. If the height is out of alignment, the picture quality will suffer.

A typical symptom of incorrect guidepost height is a band of distortion at either the top or bottom of the screen that by adjusting the tracking control you are unable to eliminate. Check the condition of the guideposts with the VCR turned off by gently turning the very top of the post with your fingers or a special adjustment tool. They must be tight.

If the guideposts are loose and easy to turn, the tiny set screw at the base has loosened, and the guidepost is probably in need of adjustment. You can verify this by gently moving the videotape up or down about 1/16 inch while in play mode. This must be done very carefully while monitoring the video. If the symptom clears up you can once again rule out the video heads as the cause of the problem.

Speed of rotation of the video drum

The video drum must spin at a precise speed of 60Hz. There are two ways to verify that the video head drum speed is correct. One way is to carefully observe the rotating drum in play mode under a fluorescent lamp, this light creates a strobe effect at a similar rate to the spinning head. The video head should appear stationary or move very slowly in a counter clockwise direction.

Another way to verify that the video head drum speed is correct is to lightly touch the top of the spinning head on a smooth area, the head should attempt to overcome the resistance and react by increasing its speed.

Replacing the video heads

Once you have determined that the video heads are defective, the next step is to replace them. You can order a replacement upper video drum from most VCR parts vendors; they range in price from \$25.00 for a two head, and up to \$80.00 for a six head. Since the video heads are mounted to the video drum with great precision, the entire drum must be replaced. Do not attempt to replace the heads until you have received the new one. Always verify that it is the correct replacement.

To replace the video head drum:

1. Remove the ant-static bar; one Philips screw.
2. Remove the two Philips screws on the top of the drum.

There are typically two types of drums. Here is the way to handle each type .

- Type 1: Desolder the wires that protrude up from below the video drum and are soldered to the top surface. Once these wires are free the drum will lift off.

- Type 2: Observe the printed circuit board on the top of the drum. This type has solid leads that protrude straight through from underneath the drum. Using a solder sucker or a desoldering braid to de-solder these leads as they are attached

to the circuit board. Once these leads are free, the drum will lift right off.

If you find the drum is stuck, you will need a special tool called a video head puller. If the drum does not lift off easily, use a puller to remove it, since you should never use excessive force when it comes to the video head drum. Video head pullers are available from most VCR parts vendors for about \$15.00.

Installing the replacement drum

Installing the replacement drum is the exact opposite of the procedure you used to remove the defective drum. Be certain to seat the new drum correctly and check for wobble by spinning it. The new drum must be put on the exact same way as the old one. Polarity matters; it can only go on one way, so pay close attention to the color of the wires and the colors on the top of the drum. Also, be extremely careful not to grab the new drum by the video heads, and avoid getting skin oils onto the drum; wearing plastic gloves is advisable.

Conclusion

Video head replacement is a repair that offers the satisfaction of instant results. Once the new drum is installed, the symptoms usually disappear and the VCR is restored back to working condition. And even considering the low cost of VCRs in today's market, VCR head drum replacement is still an economical repair. ■

IMAGINE THE BEST VCR TEST INSTRUMENTS! These are EVEN BETTER!

These VCR test instruments will actually HELP your business, by allowing BETTER and FASTER VCR repairs.

It's interesting how veterans of *trial and error* repair, buy our gauges, and *suddenly* become our BEST supporters.

STOP guessing and wasting valuable service time by continuing TRIAL and ERROR VCR repairs. The RIGHT tools make any job easier to do; these ARE the RIGHT tools for VCR repair!

Get the entire 'ESSENTIAL' check out package at a discounted '1991' price of \$1150! Try these gauges in your own shop, with a 100% satisfaction money back guarantee.



The ONLY Universal gauges for tape tension, guide heights, torques, reel heights, and MORE!



4475 GOLDEN FOOTHILL PKWY. 800-538-6894 / 916-939-4005
EL DORADO HILLS, CA 95762 24 hour FAX line: (916) 939-4114

Setting up a service bench

By The ES&T Staff

When you think about an efficient servicing environment, the hospital operating room would seem to be the epitome of an efficient work area. It is kept clean, there's a specified set of implements for every procedure, the unit to be serviced (patient) is connected to every type of test equipment needed to monitor his condition, the lighting is more than adequate.

Of course a service center can't afford to equip, or prepare a work environment the way a hospital operating room is equipped. After all, any operation costs thousands of dollars. No one pays that kind of money to have a TV or VCR worth a few hundred dollars serviced. Still, a little attention to providing a comfortable, well lighted environment for servicing technicians is almost certain to result in improvements in morale and efficiency.

How's the lighting?

Perhaps one of the most important factors in providing an efficient service bench is to provide adequate lighting. Some of the service centers that the ES&T staff have visited looked dark and gloomy. That kind of atmosphere can't help but have a negative effect on anyone who works in it.

To underscore the importance of adequate lighting, some scientists have concluded that during the winter months, when the days are short and often gloomy, some people are afflicted by a malady called "seasonal affective disorder" (SAD). The cause of this problem is lack of light entering the eye. The effect of SAD causes the individual to be tired, and even depressed.

Research has shown that an hour or so a day spent in front of a bright light can help people who suffer from this affliction to overcome it.

Adequate lighting at the bench is important, but adequate general lighting is also important. If the work area is brightly lighted, but the rest of the room is dark, the atmosphere created will be one that seems threatening. The walls of any work area, or living area, for that matter, should be lit. It helps to define the space.

And speaking of operating rooms and lighting, it might help to provide technicians with head mounted lights such as surgeons wear. So many consumer electronics have dark recesses where neither general lighting nor task lighting can reach. A small lamp worn on the head, or like eyeglasses, might considerably speed up a service procedure that would otherwise be slowed down by a search for a flashlight and a good place to prop it up so the light shines where it is needed.

Power

Every service bench has to have a lot of outlets for power. And rather than have outlets gathered in one area of the bench, there should be outlets in a number of places so that the technician can plug in an oscilloscope here, the TV or VCR over there, and plug the soldering iron in the most convenient spot. That allows the technician to adjust the arrangement of the bench, at least to some extent, to accommodate his individual work habits.

Moreover, of course each bench should be equipped with a source of isolated power. Otherwise, when the technician connects a test instrument, say an oscilloscope, and a TV set that has a full-bridge rectifier type of power supply, then proceeds to connect the scope's test probe to the TV set, there will be a puff of smoke and a destroyed diode in the set's power supply. With luck, that's the only damage that will be done.

So it's important to have a source of isolated power, prominently marked as such, at every bench, where all products to be serviced should be plugged in. One way to provide isolated power is to have a 1:1 isolation transformer at each bench. Another way to do it would be to have a single larger isolation transformer and to run wiring from it to each service bench.

The elements of a service bench

Most projects benefit from the use of a checklist. It's useful to sit down, picture the project in your mind and list as many of the requirements as you can. For example, when packing for a trip, it helps to have a list of the things that you might



need that you can check off as you put them in the suitcase. The same is true of any other project, whether it's planting a garden or renovating a room of a house.

Here's a partial checklist of the things that make up a test bench. No doubt most technicians and service managers could add to this list.

- Surface area for the product, test equipment, tools, etc.
- Storage: drawers, shelves, bins, etc.
- Tools
- Soldering/desoldering equipment
- Test equipment
- Supplies
- Lighting: general, task and spot
- Power: ac, isolated ac, variable ac/dc power supply
- ESD (electrostatic discharge) protection products
- Holder for service literature
- Communications
- Forms/writing implements
- Chemicals
- Computer terminal
- Replacement parts/supplies reception
- Fume extractor
- Foot rest

Stocking the service bench

Everything necessary to get the job done should be at the service bench. Things that are not necessary to get the job done should be elsewhere. For example, if the technician needs a DMM every day, or almost every day, it should be at the bench. But if he needs, say, a signal level meter once a week, it should be

available nearby, but shouldn't be cluttering up the work area.

The items in the checklist are pretty much self-explanatory, but here's a little detail about some of the critical elements.

ESD (electrostatic discharge) protection

Almost every electronics product made today contains large-scale integrated circuits that are susceptible to electrostatic discharge damage. If these devices are handled without the necessary precautions they may be destroyed or damaged.

Every service position should provide as much protection from this type of damage as possible: grounding wrist straps, static dissipative work surfaces, and static protective bags for storage.

Communications

In a small service center, it wouldn't be necessary to set up an elaborate communications system; the technician merely has to speak to someone nearby. In larger service centers, however, the technician at the bench may be a long way from the office or the replacement parts/supply area. If a technician needs to check on the

availability of service literature, locate certain parts, or other requirements, it could mean several trips a day, causing productivity to suffer.

Such trips could be minimized by providing intercom communications at every bench. The cost of such a system might be quickly recouped through increases in productivity. Another method of providing this communication would be by placing a computer terminal at every position that would allow the technician to place requests via the keyboard.

Parts/materials

Hand in hand with good communications goes good parts handling. In the average medium to large service center, when a technician has isolated a problem to the component level, he walks to the parts/supplies area and submits a request for what he needs. The supply person may be busy at the time, thus causing delays. A system such as this can cause a great deal of wasted time.

In one service center operated by a major manufacturer, every service position has not only a means of communication, but a pneumatic tube station. Under

this system, once the technician has isolated the problem, he can order the parts or supplies he requires and have them delivered to him without ever moving from the bench.

Of course, a system such as this requires a considerable up-front investment, but the increased efficiency can more than offset the cost.

The little things

Servicing a product such as a TV presents some peculiar problems. For example, while servicing a larger set it is sometimes necessary to perform adjustments on controls at the rear of the set while observing the results on the screen at the front of the set. One of the more efficient and well thought out service centers we know of has a large mirror fastened to the wall at the back of the bench. With this setup, it is not necessary to find a mirror and try to place it where it can be seen. It's always right there.

Fume extraction

According to literature from one manufacturer of soldering fume extractors, the fumes produced when a technician solders

Fix It. Clean It. Maintain It. Do it Now. Do it Right.

Reference books and service data for VCRs from the name you trust.

A Bell Atlantic Company

Howard W. Sams

\$29.95

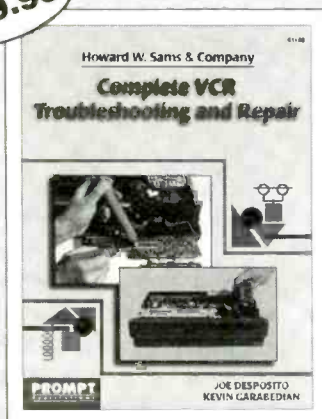

\$19.95

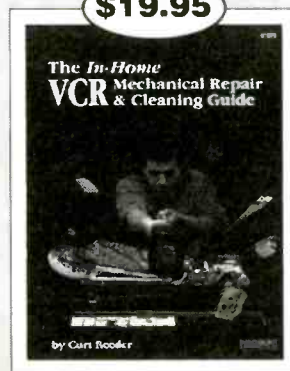

\$19.95

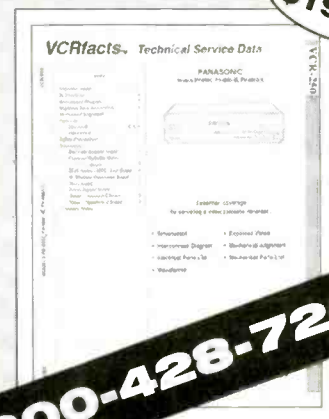

800-428-7267

may cause, or aggravate a number of problems in people exposed to the fumes: allergies, headaches, acne. In many service centers, for example those that are large and well ventilated, fumes might not be a serious problem. The existing air handling system might be able to sufficiently diffuse the fumes so that they're not a bother. In other service centers, those that are small, or have low ceilings, or in which some of the technicians do a lot of soldering, it might be wise to consider the benefits of fume extraction, especially if any of the technicians complain of discomfort.

There are a number of ways to eliminate soldering fumes, ranging from the simple and inexpensive to the elaborate and expensive. Which of these solutions should be chosen by a particular service center would depend on the size of the service center, the number of technicians, and the amount of soldering that the service center does.

For example one solution to soldering fume extraction is to eliminate it at its source. Some soldering/desoldering systems either come with, or can be fitted with tubes that attach to the soldering iron in such a way that the fumes generated during soldering are sucked into a tube and either vented to the atmosphere, or, more likely, routed to a canister where the fumes are absorbed and the purified air is then recirculated.

Another approach is to place a larger, higher volume air nozzle that sucks the air in the vicinity of the work area, including the soldering fumes, and conducts it to a canister where it is purified and recirculated into the service center. Systems can be purchased that either ventilate a single work station or ventilate several work stations.

The most elaborate fume extraction is the type that has a vent hood at each work station and ductwork that leads to a central fan that exhausts the fumes to the outside. The advantage of such a system is that it completely rids the service center of the unwanted fumes.

The exhaust method does have a couple of disadvantages. For one thing, there are environmental laws at every level; local, state and federal that control the type and concentration of any fumes vented to the outside. You might have to prove that your installation is in compliance with those laws.

The other disadvantage is that air that

is exhausted to the outside has to be made up by drawing air in from the outside. In the winter, that makeup air has to be heated. In the summer, the makeup air has to be cooled. Heating and cooling extra volumes of air can be a considerable expense.

Planning is an ongoing task

With every advance in technology, and with every addition of a product to the list of consumer electronics products, new problems arise in equipping the service bench. For example, it becomes necessary to answer questions such as whether

an existing service position, say one that is currently used for servicing of television sets will be used to service a new product as well, for example personal computers. Or will a new work station be set up for the purpose?

Either way, the same type of planning must be done anew. Storage has to be set aside for diagnostic software, specialized tools and test equipment, etc.

If service center personnel don't think these things through as they arise, the service bench will become less efficient. No service center can afford that. ■

MCM ELECTRONICS®

The comprehensive source for all your electronics servicing needs!

From Alligator Clips to ESD Protection, Frequency Generators to Oscilloscopes to Semiconductors, and everything in between, MCM Electronics stocks over 36,000 products, ready for SAME DAY shipping.



TENMA® 20MHz Oscilloscope with Function Generator

Dual channel, dual trace scope includes 0.1Hz~1MHz function generator. The perfect combination for use in the field, the lab and most service applications.

MCM order #72-3060

\$475

Price effective June 2 through July 11, 1997.

MCM Is Now Your Source For:

PHILIPS / MAGNAVOX / ECG

Authorized Original Parts Distributor



MCM ELECTRONICS®
850 CONGRESS PARK DR.
CENTERVILLE, OH 45459
A PREMIER FARNELL Company



FREE CATALOG!

1-800-543-4330

www.mcmelectronics.com

CODE: ES95

An IHVT problem

By Roger D. Redden

A customer brought a Magnavox 13S401 into my service center complaining that the screen was dark, with only the color and a few of the brightest parts of the video visible. Turning the screen control all the way up made the brightness about normal, but after the set played 2 or 3 hours, the screen became too bright, with retrace lines visible when the station switched to a dark scene. Turning the screen control down again did not decrease the brightness unless the set was turned off for a half an hour or more. Then, when it was turned back on, the screen was again too dark.

Because the screen control was not adjusting properly, I checked the voltage that goes to the screen grid (G2) of the CRT. This voltage is found on plug J13, located on the left of the CRT socket board. The manufacturer's schematic showed this voltage at 372V for a normal picture. But with the screen control turned all the way up, touching my DMM's probe to J13 produced a voltage reading only slightly over 300V.

This reading lasted for just an instant before it plunged to 205V and the picture darkened. My DMM has an input impedance of 20M Ω , and normally doesn't load a screen control source enough to cause a significant voltage drop.

A preliminary diagnosis

The voltage for G2 comes from a voltage divider contained inside the integrated high voltage transformer (IHVT). This divider is connected to a diode at the top of the first winding in the secondary of the IHVT, as shown in Figure 1. Since the high voltage was normal, I concluded that the problem must be in the resistive voltage divider. Moreover, the picture was focused, and turning the focus control, which is in the same divider network, adjusted the focus in both directions.

These conditions suggested that the divider resistors might be normal except for a problem around the screen control pot. And further, because I was unable to

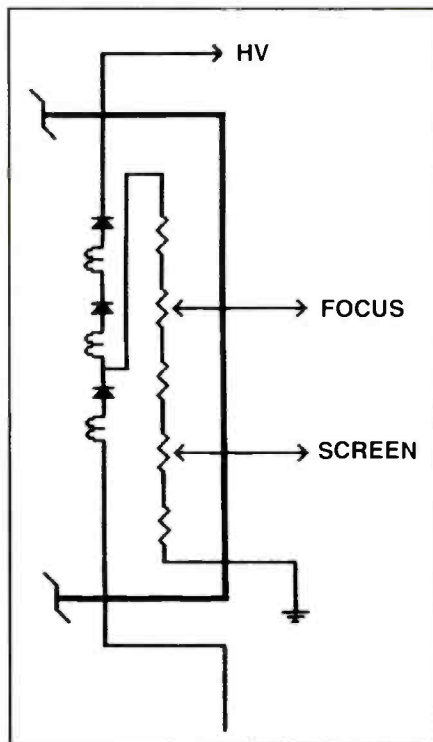

Figure 1. Power for the divider network comes from the bottom coil and diode of the secondary winding of the IHVT.

turn the brightness down after it became too bright, I suspected that the problem lay between the ground connection and the screen lead.

After discharging both the CRT anode and the G2 lead to prevent possible meter damage, I measured the resistance between ground and G2. My DMM showed an open circuit, which meant the resistance was greater than 20M Ω . My ancient vacuum tube voltmeter, capable of measuring 200M Ω of resistance, also showed an open circuit between the two points.

Even though the schematic did not show the resistance values of the divider, this reading had to be abnormal. I was convinced that I had located the problem area, and I thought that I might be able to test my theory about the voltage divider if I could get to it.

Since the set produced a picture, I did not want to risk surgery on the IHVT without consent from the next of kin: the customer. After I explained the options, the customer agreed to the purchase of a new IHVT if it were needed.

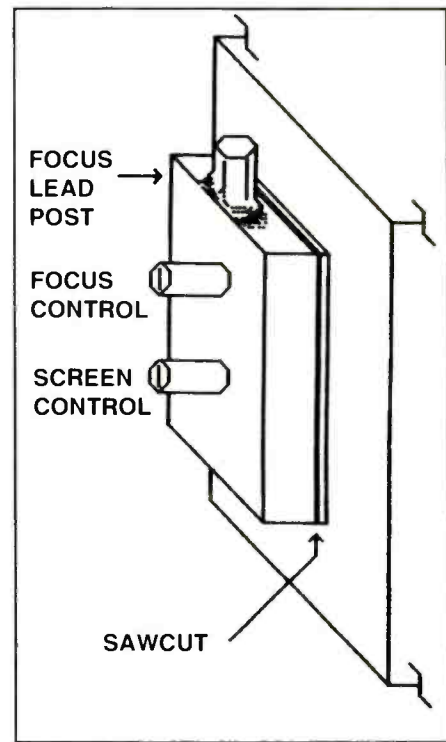

Figure 2. I saw through all four sides of the screen control cover near the body of the IHVT.

Uncovering the problem

The parts list shows 14 different IHVT's for the models covered in this series (S1/S4). Although some of the 25-inch sets have the focus and screen controls on an assembly separate from the IHVT, 13-inch sets do not. After I removed this IHVT from the board, it was clear that it was not meant to be taken apart, for the control board was sealed into place with a tough, hard adhesive. The only way I could see to remove the cover from the controls was to saw it off. After unplugging the focus lead from the IHVT to get it out of the way, I used a small hacksaw to saw just through the 4 sides of the plastic cover next to the body of the IHVT. Then I carefully pried off the cover. Figure 2 indicates the location of the cuts.

When removing the cover, I was careful not to lose the three small black cylinders that look, and compress, like foam rubber. These are conductors used to connect the ground, screen, and focus leads to the network. The screen lead is connected to the screen control when one of

Redden is owner and operator of a consumer electronics service center.

these foam-like conductors simultaneously presses against a pin from the lead and a circle of foil that surrounds that pin. This was the location of the problem in this IHVT. The foil had developed an insulating oxide that prevented the connection to the screen lead.

Repairing and closing up

I used light pressure on a small screwdriver to scrape the foil and the pin, and soldered a strand of wire between them, as shown in Figure 3. I brushed away all of the plastic sawdust, made sure the conducting cylinders were properly located, and put the cover back on. Two long plastic tie straps cinched around the cover and the body of the IHVT pulled the cover tight. When a check of the resistance between ground and the G2 lead showed the circuit was no longer open, I sealed the cut around the cover with silicone sealant.

To avoid breathing the fumes while the sealant cured, I moved the IHVT to a separate building. Since the building was unheated, I placed a light bulb within a few inches of the IHVT to speed curing, making sure there was nothing flamma-

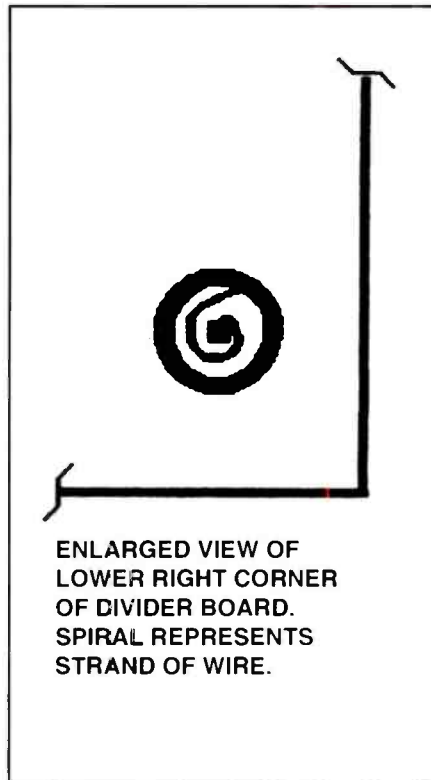

ENLARGED VIEW OF LOWER RIGHT CORNER OF DIVIDER BOARD. SPIRAL REPRESENTS STRAND OF WIRE.

Figure 3. I soldered a small strand of wire between the circle of foil and the pin from the screen control lead.

ble near the bulb. After 4 or 5 hours, I turned off the bulb, but left the IHVT to finish curing overnight.

The next day I reinstalled the IHVT. The screen control worked normally.

Surprising circuit resistance

After the repair, the resistance between ground and G2 was about 15MΩ, much higher than I anticipated. A 20MΩ impedance, such as that of my DMM, placed in parallel with 15MΩ, results in a calculated total resistance of 8.5MΩ [$R1 \times R2 / (R1 + R2)$]. When the G2 voltage was measured, this lowered total resistance caused the voltage to drop and the picture to darken, just as it had originally. But the voltage on G2 now adjusted from 140V at minimum, to 550V at maximum.

Installing the new IHVT

Now that I had conclusive proof that the IHVT was the cause of the problem, and had satisfied my curiosity as to the cause of the failure, I ordered a replacement IHVT, installed it, and returned the now-restored set to its owner. ■

ES&T READER SURVEY

It's a mini survey about you.

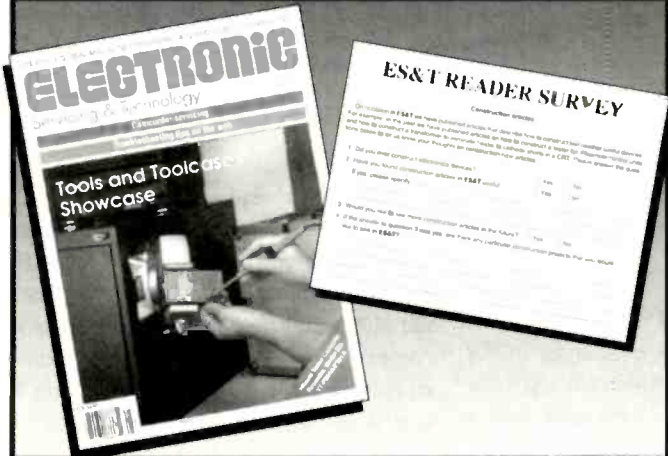

Bound into this issue is the ES&T Reader Survey card.

We would like to hear about the problems you face, the opportunities you see and the equipment you use during the course of your work day.

The postage is paid. All you have to do is fill it out and mail it.

What could be easier?

Please fill yours out and mail it today.

Your Benefits-Our Mission



- **NCA Professional Reference Guide CD**
CD comes with quarterly upgrades with thousands of parts and accessories. "Point and Click" to find all your computer needs from our **wholesale distributors**. "Search and Print" capabilities.
- **Quarterly Newsletter on CD**
Keep up with **current computer events**, learn about hot new products, and read about all the latest shows.
- **Helpline 800**
Our listing of hundreds of industry support contacts alone, is worth the cost of your membership.
- **Enhanced Business Services**
A unique variety of business services. *The power is in membership.*
- **NCA "Members Only" Web Page**
Exclusive access to NCA's WebSite with the latest industry news and gossip. This is the place where members share solutions and trade tips.
- **Trade Show Updates**
You'll be given calendars of all major trade shows, and be eligible for special show discounts on hotels, rental cars and many other perks.
- **Use of NCA Logo**
All members have full use of the NCA logo for advertising.

Please contact the National Computer Association to receive complete applications.

◆ 800.615.6224 ◆

National Computer Association ◆ 118 S. West Shore Blvd. Suite 223 ◆ Tampa, FL 33609
nca@gte.net ◆ www.nca-net.com

Circle (69) on Reply Card

Test equipment update: Repairing computer monitors

By Wade H. Lockey

Many television technicians must wonder how a computer monitor differs and how it is similar to a television receiver. Another concern of technicians must be how to approach servicing this hybrid of the television receiver.

These difficulties are compounded by the fact that the computer industry is changing at a rapid rate; almost logarithmically. Monitors are updated every six months by the manufacturers.

The most recent revisions entail energy saving (green star) higher definition (shades of HDTV), more modes of operation and even a new data connector to supersede the tried and true 15-pin HD connector. Articles have begun to appear describing and predicting the merging of the computer monitor and TV receivers.

This article will consist of monitor theory and suggestions about their repair along with case histories.

Test equipment for monitor service

If you're going to service monitors, you should first have the proper test equipment. A computer with the applicable software can be used to perform some tests on monitors, or you may want to buy one of the many color monitor testers on the market. A quality digital multimeter is a must. A HV probe helps, but when that 26KV comes up you will hear the unmistakable crackle.

Of course you will need an oscilloscope. As I will mention later, items such as a curve tracer help efficiency. A variable transformer and an isolation transformer are necessities. And, there will be a need for items such as extension cables and gender changers. A shop monitor should be available. A multiple monitor VGA splitter helps with volume work. as

Lockey is a retired consumer electronics servicing technician.

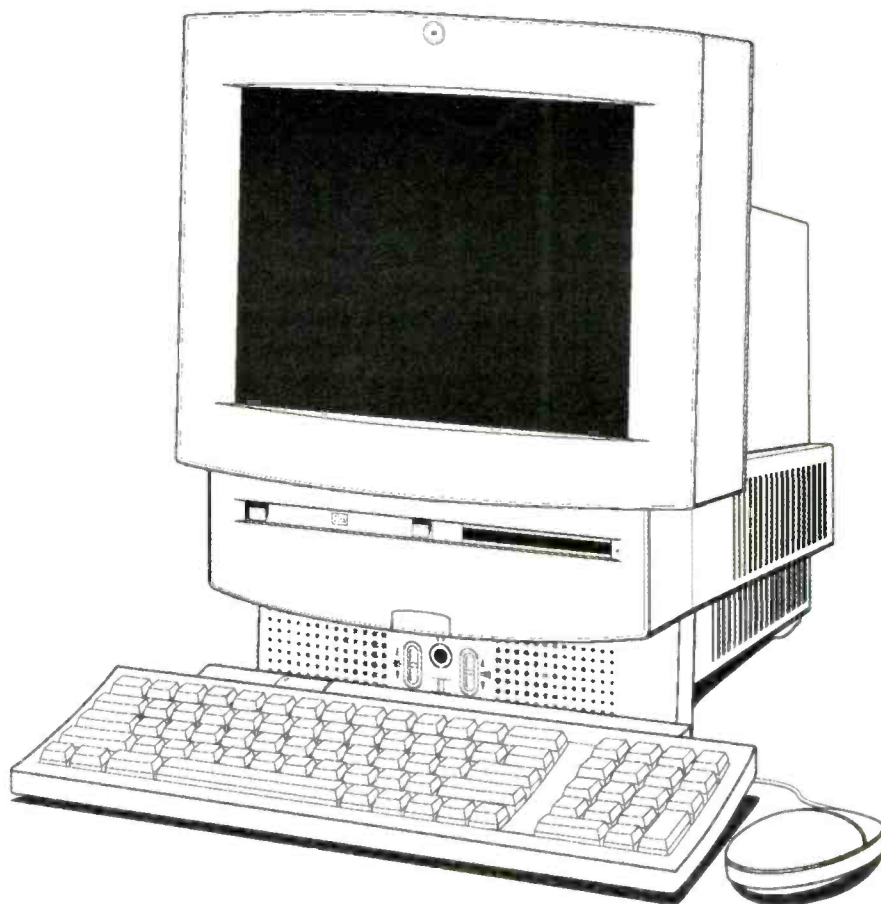

completed monitors should be burned-in for 24 hours. You should also have a set of Torx security bits.

Don't make it harder than it is

When you first take a monitor in for repair don't make a mountain out of a molehill. The data cable connector may be dirty. A card in the computer can be causing a problem.

In education applications, students are hard on the data cable and connector. You will find that problems in an educational environment are radically different from those in a commercial environment where the monitors may operate with no problem until they fail from old age.

When you accept a monitor for service, mark on the incoming job ticket, cabinet and screen blemishes and call these to the attention of your client. Give ac cords to the client and note whether the monitor comes in with a base. If you do volume work, mark client ID on chassis, cabinet and base in an inconspicuous place. Parts should be put in a plastic bag and if you remove a proprietary part, mark the part number on the chassis in case the proprietary part gets separated. Part numbers are peculiar to a certain chassis and may not be the same in other units with the same model number.

Some common monitor problems are dead monitor, missing a color or a display

No Other DMM In the World Does This. For This.

ACCURACY

FEATURES

SAFETY

VALUE

50,000
counts

Incredible Resolution for Fast Readings easily visible with 14mm characters in a large backlit LCD. The finest measurements possible in a DMM for quick diagnostics and troubleshooting.

TRMS (AC+DC)

Selectable AC or AC+DC for AC Volts and Current plus all the performance characteristics of a full-function DMM to 100kHz. True RMS assures accurate measurement of non-sinusoidal waveforms.

ZOOM Bargraph gives you a closer, more accurate look at fast changes. Increases resolution by a factor of 5 or 11, depending on model, by simply pressing the "zoom" button.

RS-232 Compatible for The Record

You can record measurements on a PC or printer, or recalibrate the instrument without opening the case, with B+K hardware & software kits (optional). You'll even be able to have full ISO9000 documentation of calibration results.



50,000µF Capacitance measures motor start and run capacitors and most computer grade capacitors. Once again, you can use the same DMM for just about everything.



Power Line Disturbance

indicators tell you if places like offices (single-phase) or industrial plants (three-phase) have a problem. Measures transient voltages >80V, high frequency (1kHz to 100kHz) harmonic disturbance >24V.

Selectable Impedance dB VA

for dB and resistive power measurements is easy. Just tell the meter the impedance and it calculates dB or resistive power automatically. Select from 600Ω, or any value from 1Ω to 9999Ω.



Temperature On Cue from -200°C to 800°C, with an accuracy to 1°C. Selectable for display in °C or °F (Model 5370*).

\$289⁰⁰

MODEL 5370 (shown)

New Technology At The Right Price. There just isn't a more accurate, higher resolution, feature-packed DMM like it anywhere. There are more digits of resolution for a lot less digits in price. And, you can even use the 5300 series to check other test instruments. Every meter is supplied with a Statement of Calibration. And, there's nothing safer, because all B+K 5300 Series ASYC II (Advanced Safety Concept) DMMs are designed to stringent safety standards. You'll never have to worry about using it virtually anywhere. The B+K 5300 DMMs are available now at your favorite B+K Distributor.

	Accuracy (DC Volts)	TRMS (AC or AC+DC) on AC Volts & Current	Capacitance to 50,000µF (50 mF)	ZOOM Bargraph Equiv. 170 segment Resolution	Power Line Disturbance Indicator Transient/Harmonic	Relative Mode	dBm	Resistive Power
5390	0.025%	✓	✓	✓	✓	✓	✓	✓
5380	0.025%	✓	✓			✓	✓	
5370	0.05%	✓	✓	✓	✓	✓	✓	
5360	0.1%	✓	✓			✓		

Specifications & Prices subject to change without notice. © B+K Precision, 1997 *Connect to B+K Model TP-5300 Temp. Probe

See the complete 5300 Series Specifications on our web site and you'll be convinced. B+K offers industry's largest selection of value-based DMMs, test instruments and accessories. Immediate response via e-mail.

www.bkprecision.com

6470 W. Cortland Street
Chicago, Ill 60707
(773) 889-1448
Fax: (773) 794-9740

Circle (111) on Reply Card



BK PRECISION

Setting New Standards In Performance & Value

or deflection problem. Don't forget, monitors have external height, width, centering and even convergence controls.

Assorted problems

I have run into many intermittent conditions which were caused by the data connector, a temperature-sensitive component or poor solder joints on components whose pins are plated with conductive metals that tarnish after long use. This condition can cause variation of color intensity or flicker. Another common problem is damaged pins on "D" connectors caused because users, unfamiliar with them, attempt to plug them in upside down and scrunch the pins.

I once encountered a monitor on which the display shifted 25% to the left after it had been operating for several minutes. I suspected that the problem was a defect in the horizontal processor. I used a coolant spray and a heat gun to alternately cool and heat the processor. The picture returned to normal when I cooled the processor and shifted back to the incorrect position when I heated the processor. This confirmed my suspicion.

On a whim, I kept the heat gun on the IC for about 30 seconds. The display shifted back to its normal center. I left the unit to burn-in for 24 hours and the display stayed centered. Since the unit was under contract, if this had not corrected the problem it would have come back. I never saw the unit again.

Raster centering and horizontal phase

At this juncture, I want to explain something that was never explained when I took computer technical courses. While there is raster centering or "shift" as IBM calls it; there is also "horizontal phase." Horizontal phase is the monitor parameter that affects centering of the data within the raster. In television, this is standardized and set by the Federal Communications Commission in cooperation with broadcast stations. In computers, this AFC signal (horizontal sync) is set by the monitor card in the computer and varies mode to mode and can also be varied by external pots as well as pots on the chassis. In other words, the horizontal afc, preset in a tele-

vision, is variable in computers and is called "horizontal phase".

Some solder joint problems

As with any other consumer electronics product, computer monitors are subject to intermittent failures as a result of poor solder joints. Some of these solder joint problems may not show up until the monitor has been in operation for prolonged periods of time.

For example, I was working on two Unisys monitors that had been brought in with the complaint that the display failed intermittently. Since the monitors worked for 24 hours on burn-in, I thought that it was a "customer" problem; but I decided to let the monitors continue to operate a while longer. After 36 hours the display on one of them disappeared.

The problem turned out to be cracked solder joints at the filament connections on the CRT board. I could see these cracks when I held the board under a fluorescent magnifier lamp, which I consider a "must" piece of equipment for monitor servicing. Since I encountered this problem, whenever a monitor of this brand is

ORGANIZE AND PROTECT YOUR COPIES OF

Electronic Servicing & Technology



Now there's an easy way to organize and keep copies of your favorite magazine readily available for future reference.

Designed exclusively for *ES&T* by Jesse Jones Industries, these custom-made titled cases and binders provide the luxury look that makes them attractive additions to your bookshelf, desk or any location in your home or office.

Whether you choose cases or binders, you'll have a storage system that's durable and well organized to help protect your valuable copies from damage.

Quantity	Cases	Binders
One	\$ 8.95	\$11.25
Three	\$24.95	\$31.85
Six	\$45.95	\$60.75

Add \$1.50 per case/binder for postage and handling. Outside USA \$3.50 per case/binder. (U.S. funds only)

- Cases and binders designed to hold a year's issues (may vary with issue sizes).
- Constructed of reinforced board, covered with durable red leather-like material.
- Cases V-notched for easy access.

- Free personalization foil for indexing year.
- Binders have special spring mechanism to hold individual rods which easily snap in. This allows magazines to be fully opened for easy readability.
- Title hot-stamped in gold.

Call TOLL FREE 7 days, 24 hours

1-800-825-6690

Electronic Servicing & Technology Jesse Jones Industries, Dept. 95 EST, 499 East Erie Avenue, Philadelphia, PA 19134

brought in for service, the first thing I do is resolder the filament pins.

The filament source for these monitors is dc. I surmise that the solder was decomposed by electrolytic action of the dc current. Many monitors power the CRT filaments from the flyback.

Getting inside the monitor

After the preliminary inspection, it is time to get down to brass tacks and open the case. The cases of monitors are put together so tightly, that it is difficult to get them apart. The tool of choice for this procedure is called a "case cracker". These invaluable tools are available from most distributors that sell computer-related products. Some manufacturers use Torx security screws. I even have a #8 security Torx bit to remove screws holding sweep transistors to their heat sinks. These Torx bits are available through electronic suppliers.

Evaluating the problem

If you're working on a dead monitor and the power supply is separate from the rest of the monitor, disconnect the molex plug. If the power supply springs back to life, the power supply is not the problem. A shorted horizontal output transistor or a damper diode may be the cause of shutdown of the power supply. Look for a bad flyback transformer loading down the B+. Another possible cause of a dead unit is a defective solder joint at a heavy horizontal sweep component.

A bad horizontal driver transformer or open "B" resistor can deactivate high voltage. I serviced an Apple monitor on which the primary of the horizontal driver transformer was open. Careful inspection of the circuit revealed the break and I repaired it. It was fortunate in this case that the problem was not caused by the transformer, because replacements for this particular transformer were unavailable. Shorted horizontal coupling capacitors have also been known to cause shutdown of the power supply.

Power supply integrated with main board

If the monitor has a power supply integrated with the main board, you'll have to shift gears. When one of these units is dead and you suspect the power supply, check the switching transistor and damping diode(s) and rectifiers from the secondary of the switching transformer. Defective vertical output ICs usually cause foldover or absence of vertical deflection.



Kits That Fit You And Your Instrument



Pomona's latest family of Test Companion™ Test Accessory Kits are designed to enhance your FLUKE, TEKTRONIX, HEWLETT PACKARD or WAVETEK hand-held or benchtop instruments. Each kit contains the newest Pomona test accessories for test reliability, versatility and longer service life.

Simplify LAN Diagnostics



Make troubleshooting coaxial cable local area networks (LANs) a breeze with Pomona's Coaxial LAN Test Kits. BNC cables, breakouts, terminations and adapters for a wide impedance range. They're suited for most LAN testers and FLUKE LAN Test Meters. Complete with a rugged carrying case.

Ask for your FREE copy of Pomona's New Test & Measurement Accessories Catalog. See your Pomona Distributor or call us. And visit us anytime at www.ittpomona.com

Circle (64) on Reply Card

ITT Pomona Electronics
1500 E. Ninth Street
Pomona, CA 91766-3835
(909) 623-3463
FAX (909) 629-3317

ITT Pomona Electronics
AN ITT CANTON COMPANY

MONITOR REPAIR SOFTWARE Now Only \$49!

Resolve Monitor Repair Database

Starter Version\$49

2,223 repairs on
362 monitors and more!

Version 3.20\$199

3,800 repairs on 989 models,
manufacturers cross reference,
FCC ID, Component Sources
and database editor.

FCC ID List.....\$19

5,437 manufacturers by FCC No.
with full addresses.



ANATEK
CORPORATION

PO Box 1200
Amherst, NH 03031
1-800-999-0304
603-673-4342
info@anatekcorp.com

**Operators of the
Electronic Repair Center**
<http://www.anatekcorp.com>

Circle (60) on Reply Card

While I have encountered a myriad of flyback transformer problems, I have never seen a monitor problem that was caused by a defective yoke.

A problem leftover from TV

There is an intermittent condition that is left over from television. In monitors, there is an integrated circuit that takes its shutdown pulse from the flyback transformer. In the case of Sony monitors, the shutdown pulse comes from the voltage tripler, which is orange. This system occasionally experiences random shutdown.

Here's a tip: if you check switching supply diodes in circuit, if one shows short, disconnect the CRT socket and recheck the condition of the diode, as the filament voltage for the CRT usually comes from the switching supply.

RGB circuitry

Almost every monitor has RGB circuitry on CRT socket boards. Lately, manufacturers have started to put RGB circuitry on the chassis. A helpful procedure that I have used is to turn on a missing

color and trace it through with a scope or meter. Familiarize yourself with the proper voltages in a working color circuit.

One major cause of problems has been the RGB and video IC; for example, an LM1203. This IC can cause poor video or a missing color. If I see a lack of gain in color and/or video, I change the IC.

On one IBM monitor I serviced, the RGB IC produced color but no video. The 12V V_{CC} was present but the 5V V_{CC} for the video was not there. If you replace one of these ICs, use a socket if you can.

In another interesting problem I have encountered in a number of brands and models of monitor, the display would take 30 minutes to come on. In this case the cause was a defective 100pF cap from G2 to ground. The leakage of this ceramic capacitor did not show on a digital meter.

You may find it useful to collect IC and transistor information. I have found solid state component representatives generous with their specification books.

One of the procedures I use is to blow up sections of schematics or IC pinouts and insert data on them. This improves efficiency when working on a problem.



Synthesized Function Generator SFG-830 w/RS-232

INSTEK, a name that engineers and technicians can trust. All of our products are built in our ISO9002 certified manufacturing facilities.

Products such as:

Arbitrary Synthesized Function Generators(30MHz); Programmable Electronic Loads (300Watts); and our NEW range of Analog (600G Series) Oscilloscopes

PEL-300



Programmable ELECTRONIC Load

ASK for our 41-page, 4-color catalog which is exclusively devoted to the most popular varieties of benchtop and portable test equipment. Among the equipment described in detail are Oscilloscopes, Signal Generators, Function Generators, Power Supplies, Programmable Power Supplies, DMMs, Electronic Programmable Loads, and Audio Generators. The catalog includes a color photo of each piece of equipment and tabulates a complete set of specifications.



INSTEK ISO 9002 CERTIFIED MANUFACTURER
Test & Measuring Instruments

For a complete catalog of Instek equipment and the Distributor nearest you, please contact: **INSTEK Corporation**

1205 John Reed Court ■ City of Industry, CA 91745 ■ 818-336-6537 ■ FAX 818-369-1748

A change of specification

The availability of detailed information on ICs would have proved valuable to me in one case in which I replaced an IC and encountered an unusual problem. We had just received a lot of RGB ICs. I installed one of these ICs in a monitor. When I turned the power on, I noticed blue blooming. Further investigation showed that I was unable to adjust the blue gain.

I called National Semiconductor, the manufacturer of these ICs, and discussed the problem with an applications engineer. It turns out that this particular IC had been reengineered to improve gain and bandwidth. This revision was indicated by a letter suffix number. The vendor was not aware of this and only stocked the new number. Substituting an original, in this case, LM1203N, cured the problem.

I suspect that the revision of this IC was to accommodate HDTV. Current models of monitors are using a RGB heat sinked IC in place of discrete RGB transistors.

Replacement parts

Obtaining replacement parts for monitors is a little different from obtaining replacement parts for TV sets. Many com-

mon replacement items such as data cables are available from local suppliers, or from some of the catalog companies.

Common small transistors and diodes can be replaced through the usual ECG, NTE or SK sources. Remember, however, horizontal output transformer and many switching transistors and FETS must be exact replacements that bear the same manufacturer's part number as the one you'll find on the case of the device.

I recently had to replace a BU2520 DX horizontal output transistor. I was informed that the "X" pertained to that monitor manufacturer and the "X" suffix should be used. After some difficulty, I received two of these transistors and found that they were replaced by "F" suffix readily obtainable through solid state suppliers catering to the computer field.

Whenever you replace a horizontal output transistor, feel the case with your finger after the unit has been operating for about five minutes. The transistor should just be comfortably warm.

Here's another tip. Some monitor manufacturers leave out the heat sink compound when they install the HOT. If a semiconductor is mounted on a heat sink,

always apply heat sink compound between the package and the heat sink.

The most reliable parts in a monitor are the CRT and yoke. If a customer has, say, an old 14 inch with a weak CRT, a good CRT out of a discarded monitor can be used. Just be sure that you get the customer's consent before you make this substitution. CRTs last seven to nine years on the average and it is not economical to put in a new CRT.

Flyback transformers in monitors

Flybacks are the "planned obsolescence" feature of monitors. They are a prime electronic problem in monitors. My experience has been that before a monitor is put into production, a meeting of engineers is held to make sure the flyback number is put on so that it must be removed to obtain the part number in order to give an estimate.

Appearance parts are available through the manufacturer. You don't have to worry about a tuner or IF strip in a monitor; these items are in the computer.

A future article will describe other repairs, and provide further details of monitor circuit design. ■



The Professional
**Electronics
Technicians
Association**
and the **Satellite Dealers
Association**

Join Us

CET Certification - FCC License Exams

At all cities and military bases. Study materials on disk, paper and video. Free retake if you do not pass CET 1st time. Test Review available. **Option areas:** Consumer, Industrial, Computer, Satellite, Biomed, Radar, Wireless and Telecommunications, RF Video Distribution, Fiber Optics, Customer Service, Satellite Installation.

Employment Help

Join ETA-SDA. Send your resume - We can help. Employers: Call us for highly skilled Certified Electronics Technician staff workers.

Membership includes Technical Tips; Technician Assn News journal, Employment assistance; Help line, Technical and business monographs; Seminars on site or via satellite; Participation on tech committees for CET and skills standards. Leadership training; Annual Convention; Student Chapters; Industry recognition; Networking; discounts and a lot more.

THE ASSOCIATE CET Exam Books

New Study Guides for the Associate Level CET exams. Book 1 contains 248 sample CET Exam Quiz questions and answers. Multiple CET authors. Book 2 different sample quizzes - latest exam topics plus complete listing of over 380 CET exam test sites. Written by CETs, electronics instructors and working technicians. Great study material for every professional electronics technician.

317-653 4301

602 N Jackson

Greencastle, In 46135

<http://www2.fwi.com/~n9pdt/eta.html>

Circle (71) on Reply Card



TEST HIGH-END MONITORS FOR A LOW-END PRICE

Test displays up to 1600 x 1280 with the new 801SL video generator. The programmable clock rate of up to 160 MHz generates up to 256 colors from a palette of 16.7 million colors. Over 150 test images and over 100 formats come preprogrammed. BNC, CGA/EGA, Mac, VGA, and VESA output connectors make it simple to service most kinds of monitors. Portable, lightweight and user-friendly, the 801SL also has an optional carrying handle/support stand.

QUANTUM DATA®

2111 Big Timber Road • Elgin, IL 60123 USA

Phone: (847) 888-0450 • Fax: (847) 888-2802

URL: <http://www.quantumdata.com>

E-mail: sales@quantumdata.com

Circle (7) on Reply Card

Servicing television tuner problems

By Bob Rose

Replacing a defective television tuner often means presenting your customer with a hefty repair estimate and risking the loss of the job. After all, he or she can go to K-Mart, Wal-Mart, or some other discount store and purchase a new nineteen-inch set for less than \$175.00 or a twenty-five inch set for about \$250.00. Why, therefore, spend \$100.00 to get the old one fixed?

I am assuming that you use a depot to get your tuners repaired. The cost of new tuners almost mandates getting the defective ones fixed. (A rebuilt MTT module costs less than \$50.00, but a new one can cost as much as \$110.00 in my area!)

I wrestled with this dilemma for a long time before deciding that a tuner is just a piece of electronic equipment. Somebody designed and manufactured it. When it breaks somebody fixes it. Why shouldn't I be the one who fixes it? Now I repair most tuners myself. The result is I get jobs I used to lose, and the extra profit goes into my bank account.

I cannot, however, repair all the defective tuners I see. A service depot has elaborate test jigs for troubleshooting and repairing tuners. I do not. Neither do I have access to the technical data and schematics I need to service all brands of tuners. But I am able to repair a large percentage of defective tuners, and you can too. I have had good results with Philips, Sanyo-Fisher, Zenith, and RCA tuners.

Philips tuners

I began my venture into tuner repair with NAP's 340 319 1003 and 340 319 1004 tuners. These are used in several sizes and models of television sets and in many of their projection televisions. The problem that affects these tuners is usually like the one I encountered yesterday. A customer complained that when he turned his set on, it locked on one channel. Even though the channel numbers

changed, the picture and audio did not. Channel number changes indicate that the microprocessor is working, and the problem lies in the tuner.

This is a fairly large tuner, and you would think it would be easy to service. That's partly true. However, this problem is caused by a defective controller IC, which is rather difficult to change. (I wonder why the manufacturer didn't locate it in a more accessible location). But, I've found that with a little practice I can change the chip in about fifteen minutes. Here's how to go about it.

First, remove both covers. Note that the circuit board is enclosed in a metal frame. Some servicers completely remove the frame, but I find that too time-consuming. Position the tuner with the antenna connection to your right (Figure 1). Use a pair of heavy dikes to cut the metal between the left side of the tuner and the bottom. Wick out the solder at the points noted in Figure 2. Then, peel the bottom away from the circuit board. This allows access to the chip.

Be careful when you remove the controller IC because the circuit board and/or traces can be damaged. I suggest a desoldering tool to remove most of the solder from the chip's pins and a small soldering iron and desoldering braid to loosen the pins in their holes. Use an IC puller, or a small screwdriver to work the IC out of the circuit board. The rest of the repair is simple. Insert the chip, solder it in place, and put the tuner back together.

What is the cost to you? The chip is a SDA 3412. It is available from distributors for approximately \$8.55 in lots of one to four. I have found that the SDA 3412 will repair almost all of the problems this tuner causes.

Servicing some other Philips tuners

The 340 313 1001 (1002, 1003, 1004, 1005) NAP tuner is also easy to repair. Most of problems with this tuner are also caused by a defective controller IC. The difference is this tuner is considerably

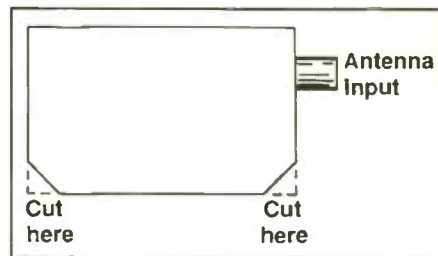

Figure 1. To gain access to the NAP 340 319 1003 and 340 319 1004 tuners in order to service them, position the tuner with the antenna connection to your right as shown. Use a pair of heavy dikes to cut the metal between the left side of the tuner and the bottom.

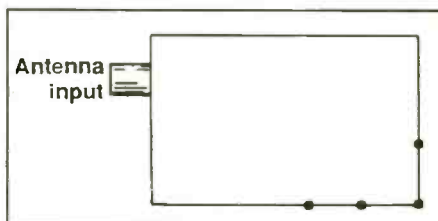

Figure 2. For the tuner of Figure 1, to separate the circuit board from the frame, wick out the solder at the points shown. Then peel the bottom away from the circuit board. This allows access to the chip.

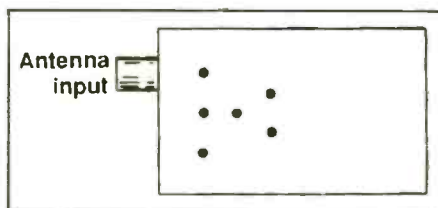

Figure 3. To gain access to the 340 313 1001 (1002, 1003, 1004, 1005) NAP tuner use a desoldering tool to remove solder at the points shown. Then remove the cover to expose the circuit board.

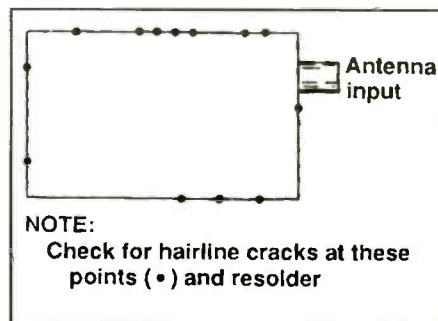

Figure 4. If you find a SFS tuner marked "1AV4F1BAM0010," part number 645 000 0843 (used in about 38 different models) to be defective (snowy or no picture), the problem may be caused by broken solder connections inside the tuner. Resolder the points indicated here.

Rose is an independent consumer electronics business owner and technician.

EIA/CEMA

Hands-On Technical Training Workshops

FOR ELECTRONICS INSTRUCTORS AND TECHNICIANS

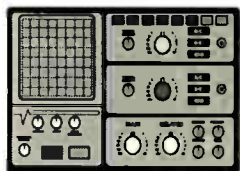

The Consumer Electronics Manufacturers Association (CEMA), a sector of the EIA, is offering the following courses. These 3-5 day technical workshops cover theory, hands-on training, and troubleshooting techniques. The technician workshops are co-sponsored by state and national service associations. There is a minimal fee of \$50 (\$150 for Monitor classes). The educator workshops are co-sponsored by the respective state department of education and may be provided free or at a minimal charge to educators.

Anyone interested in attending should contact the respective host for space availability and details.

(PCS) - PC SERVICING
 (MON) - COMPUTER MONITOR SERVICING
 (UPC) - MICROPROCESSOR/PC SERVICING

(CTV) - COLOR TV TECHNOLOGY & SERVICING
 (VCR) - VCR TECHNOLOGY & SERVICING

1997 TECHNICIAN WORKSHOP SCHEDULE

TYPE	CITY/STATE	DATE	HOST	TELEPHONE #
MON	WALNUT, CA	4/22-24	BRIGID WALL	(703) 907-7656
PCS	SALT LAKE CITY, UTAH	5/20-22	RANDY WHITEHEAD	(801) 269-1800
MON	LEWISTON, ID	5/29-31	BILL STREETER	(208) 799-2439
CTV	WALNUT, CA	6/3-5	BRIGID WALL	(703) 907-7656
MON	SALT LAKE CITY, UTAH	6/10-12	RANDY WHITEHEAD	(801) 269-1800
PCS	BELOIT, KS	6/11-13	KEITH KNOS	(316) 624-5908
VCR	LOS ANGELES, CA	6/16-20	JACK GEER	(213) 745-2013
CTV	WEST PALM BEACH, FL	6/23-25	BOB LAQUERRE	(561) 842-8324
VCR	BREMERTON, WA	7/7-11	MICHAEL SZYMKEWICZ	(360) 478-4777
VCR	TAMPA, FL	7/7-11	BRIGID WALL	(703) 907-7656
MON	RIVER GROVE, IL	7/14-16	BRIGID WALL	(703) 907-7656
MON	WALNUT, CA	7/23-25	BRIGID WALL	(703) 907-7656
PCS	GRESHAM, OR	8/18-20	VERN HARTSHORN	(503) 667-7117
MON	CALIFORNIA	8/19-21	ELOY FIERRO	(818) 760-0999
PCS	CALIFORNIA	9/17-19	ELOY FIERRO	(818) 760-0999
PCS	CALIFORNIA	9/22-24	ELOY FIERRO	(818) 760-0999
CTV	RIVER GROVE, IL	10/13-15	BRIGID WALL	(703) 907-7656

1997 EDUCATOR WORKSHOP SCHEDULE

TYPE	CITY/STATE	DATE	HOST	TELEPHONE #
UPC	NORMAN, OK	6/2-6	JIM BULLINGTON	(405) 743-5424
UPC	SHELBY, OH	6/9-13	JEFF MERICKEL	(614) 466-8782
PCS	RALEIGH, NC	6/23-25	BOB DICKERSON	(919) 715-1708
PCS	LEXINGTON, KY	6/25-27	PAUL TURNER	(606) 246-2400
PCS	LINCOLN, RI	6/30-7/2	KENDRA BALDWIN	(401) 728-1500
UPC	VA BEACH, VA	7/21-25	RICHARD ROSS	(804) 225-2828
PCS	SPRINGFIELD, MO	7/23-25	DENNIS HARDEN	(573) 751-2584
VCR	LITTLE ROCK, AR	7/28-8/1	RON SHIRTZER	(501) 682-1350
PCS	LOGAN, UT	8/11-13	WARD BELLISTON	(801) 797-1801
VCR	SYLMAR, CA	8/11-15	ABE ATARODI	(818) 364-5151



Consumer Electronics Manufacturers Association
 2500 Wilson Blvd., Arlington, VA 22201
 Phone: (703) 907-7656 Fax: (703) 907-7968



Circle (112) on Reply Card

Wkconcl.doc

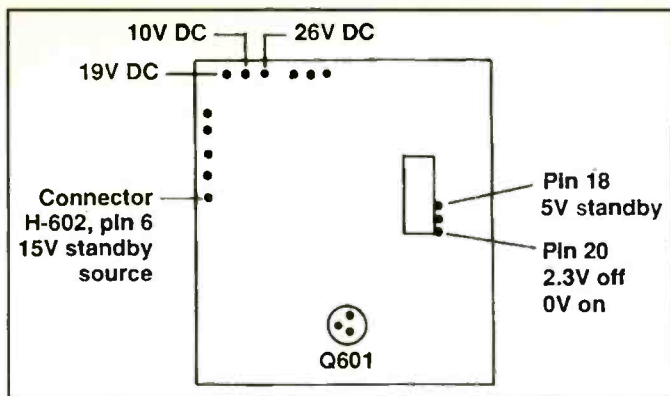

Figure 5. This view of the RCA MTT tuner module shows some of the specified voltages.

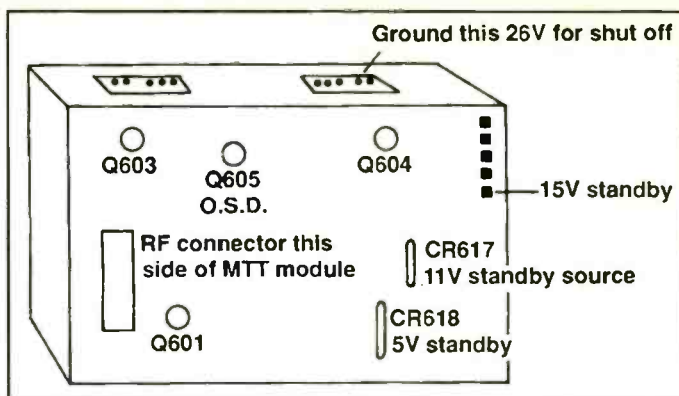

Figure 6. This view of the RCA MTT tuner shows some of the specified voltages.

GOT BANDWIDTH?

LG Precision offers a comprehensive line of affordable Analog and Digital Storage Oscilloscopes for your diagnostic needs.

- Signal Delay Lines
- Variable Holdoff
- TV Sync
- Max. Sweep Time of 2ns/div.

Digital Storage with CRT Readout and Cursor Control	Analog CRT Readout and Cursor Control	Analog
OS-3020: 20 MHz, 20 MS/s OS-3040: 40 MHz, 20 MS/s OS-3060: 60 MHz, 20 MS/s	OS-902RB: 20 MHz, Delayed Sweep OS-904RD: 40 MHz, Delayed Sweep OS-5100RA: 100MHz, 4CH, 8Trace, Auto Set OS-5100RB: 100MHz, 2CH, 4Trace, AutoSet	OS-5020P: 20MHz, Basic OS-9040D: 40MHz, Delayed Sweep OS-9060D: 60MHz, Delayed Sweep OS-9100P: 100MHz, Delayed Sweep OS-8100A: 100MHz, Delayed Sweep OS-9020G: 20MHz with 1 MHz Function Generator

Don't forget the other sensibly priced instruments available from LG Precision (Sweep Function Generators, Frequency and Universal-Counters, Bench Power Supplies, and Bench and Handheld-Digital Multimeters).

LG Precision

New Name of Goldstar Precision

13013 East 166th St., Cerritos, CA 90703 Tel: 562-404-0101 Fax: 562-921-6227
E-Mail: lgpa@koa.pdc.net Home Page: <http://www.oscilloscope.com>

smaller, and the IC in question is a surface mount component.

To replace this controller IC, position the tuner with the antenna connector to your left (Figure 3). Use a desoldering tool (like a solder sucker) to remove the solder in the indicated areas. Remove the cover to expose the circuit board. The controller is the IC located near the bottom of the circuit board. Don't let its size confound you because this fix is easier than the preceding one.

Use a sharp knife, such as a hobby knife, to cut the leads of this IC as close to the body of the package as you can. Remove the body of the IC package with a pair of tweezers or small pliers. Clear away the debris with desoldering braid and a small soldering iron.

When the area has been cleaned, put a small amount of solder on the first pad. Position the chip on the circuit board, line up the pins with the pads, hold the chip in place with a small pick, and melt the solder you previously applied. This procedure makes it easier to solder the chip in place. Inspect your work to make sure that the solder connections are good, and that there are no solder bridges. Put the tuner back together, and install it in the set.

The Philips part number for this controller is 4835 209 17354. It costs about the same as the SDA 3412. Again, this replacement part will repair most of the 340 313 tuners, and it will save you a bundle of money over the long haul.

Sanyo-Fisher tuners

Another tuner that is fairly easy to repair is the SFS tuner marked "1AV4F1-

(Continued on page 39)

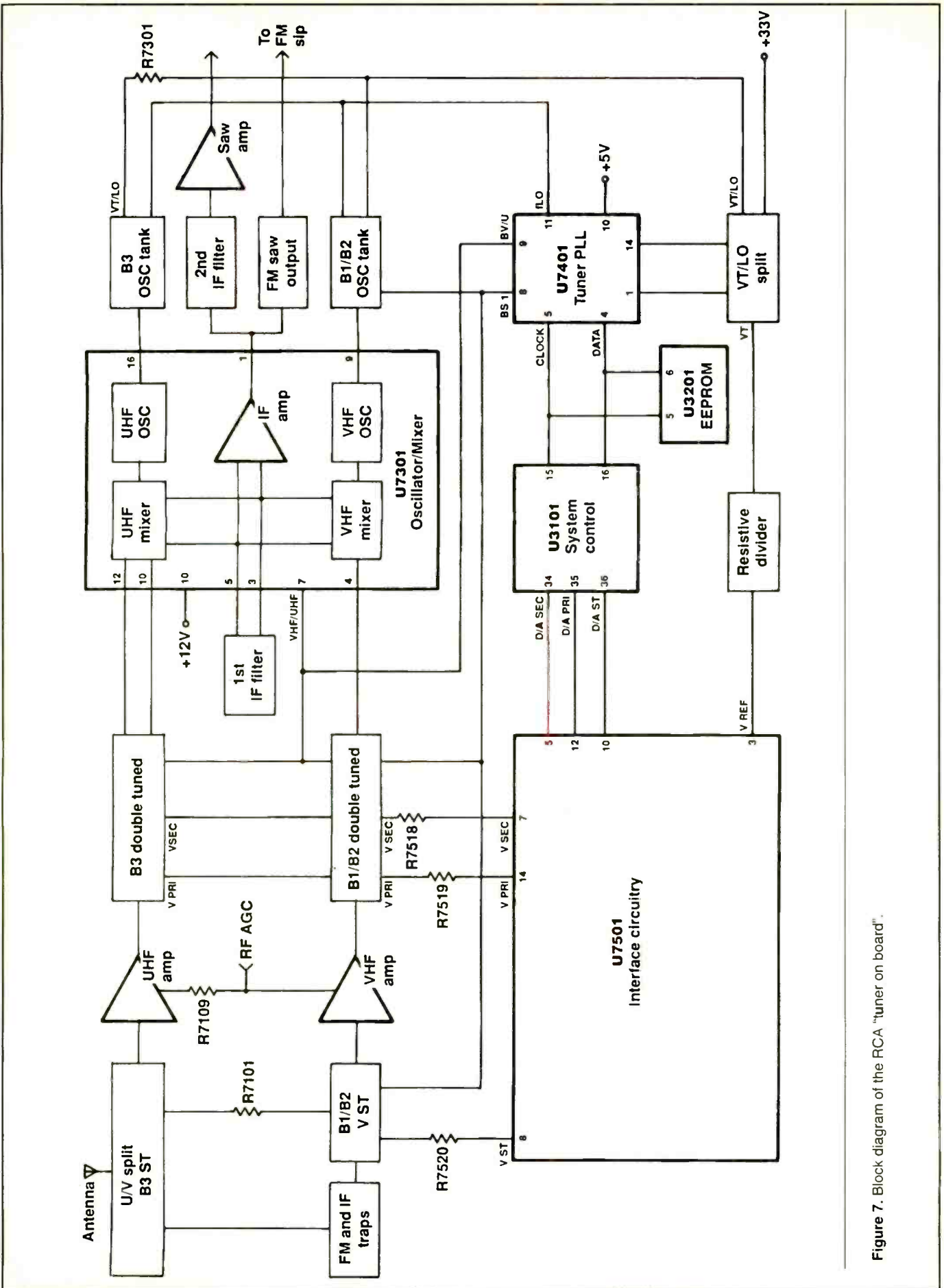
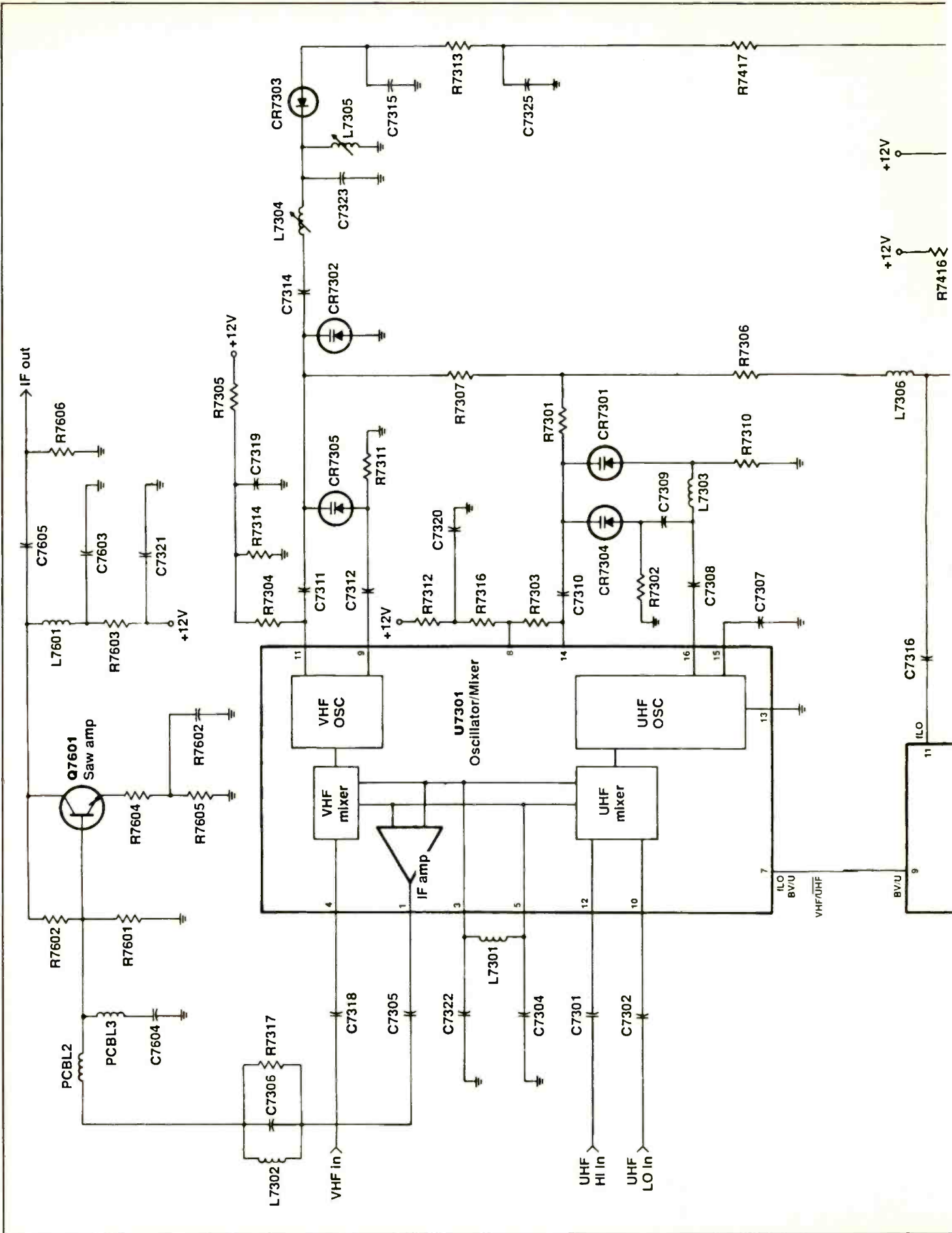
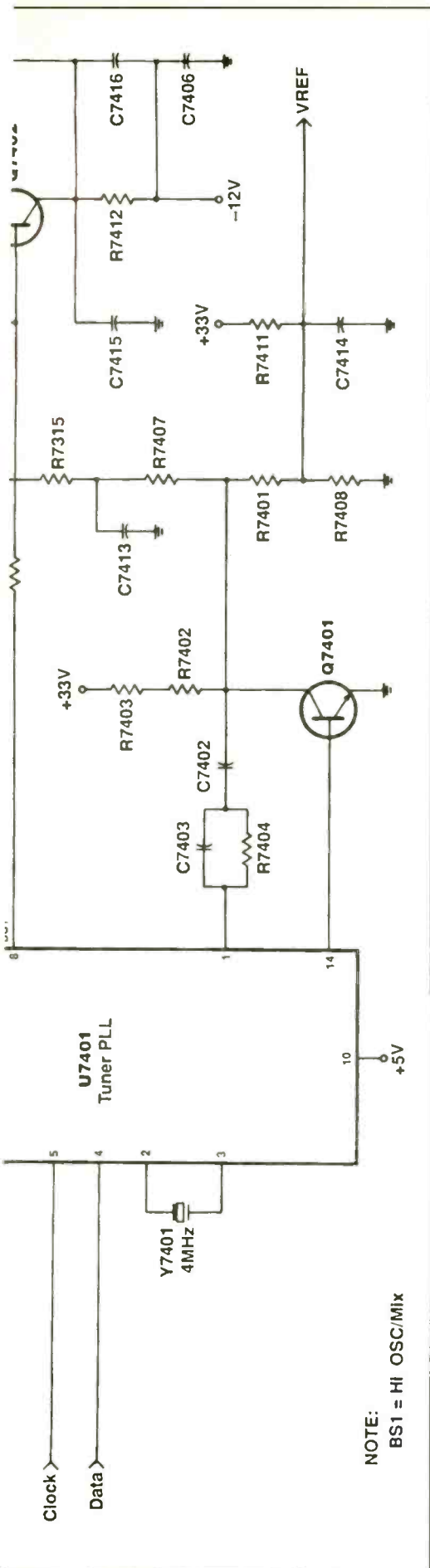

Figure 7. Block diagram of the RCA "tuner on board".





← **Figure 8.** This schematic diagram provides detail of portions of the "tuner on board" circuitry found in RCA TV sets.

BAM0010," part number 645 000 0843. It is used in about 38 different models.

The usual complaint when this tuner is defective is that the picture is snowy, or that there is no picture at all. The set may play fine when it is first tuned on, but the quality of the picture degrades significantly as the TV warms up.

This problem is caused by broken solder connections inside the tuner, usually at its back (the side opposite the antenna connector). I have found that you have to take the tuner out and inspect it under a magnifier to confirm this condition. Tapping it with the handle of a screwdriver may or may not confirm the problem. Resoldering the indicated points (Figure 4) will solve the problem.

Lightning damage

These tuners are also susceptible to lightning damage. I find that in about fifty percent of the cases the only damage is a destroyed hairline trace that runs from the RF input to the first series of components. The trace is difficult to see because it is routed underneath two other components. Once you see that it has been vaporized, simply replace it with a small wire, and you will probably have repaired tuner.

Lightning invariably leaves its signature as a black mark on the inside cover of the tuner. I saw a television set yesterday that had been victimized by Mother Nature. The problem was absence of low band VHF. I found a shorted diode underneath the lightning signature (black spot on the cover), replaced the diode, and the tuner worked fine.

Similar problems in Matsushita sets

Older Matsushita (Quasar-Panasonic) TVs have tuners that develop a similar problem. The complaint is that the TV works fine until it has been on for a while, and then the picture gets very snowy and the audio becomes scratchy. Close inspection of the inside of the tuner usually turns up at least one barely visible crack in the solder that attach-

Safest And Most Effective Restoration!



NEW!

CR7000
"BEAM-RITE"[™]
CRT Analyzer &
Restorer

Easily Test And
Restore CRTs With
The Most Complete Tests
Available For Added
Profit And Security!

The Safest And Most Effective Restoration Techniques Available

- The multiple levels of restoration guarantee the safest possible restoration
- Six levels of "Progressive Restoration"
- Self-limiting shorts removal function
- Three times the restoration range of other testers

We'll prove it!

Compare the new CR7000 to your current CRT tester.

Call 1-800-SENCORE

for a free 10 day trial.

SENCORE

3200 Sencore Drive, Sioux Falls, SD 57107

Direct: (605)339-0100 Fax: (605)339-0317

Circle (73) on Reply Card

ES&T Calendar

Spring CES '97 co-located with
COMDEX/Spring WINDOWS
WORLD
June 2-5, 1997
Atlanta, GA
703-907-7674

VPEA (VA) Annual State Convention/
Mid-Atlantic Assoc. Conference
June 6-8, 1997
Williamsburg, VA
804-874-8818

T-E-A (TX)/G-SPEC Convention
June 12-15, 1997
San Antonio, TX
512-476-3551

CES Habitech '97 - The Home
Systems Trade & Training Show
June 24-26, 1997
Dallas, TX
703-907-7674

CEMA Manufacturer/Retailer Summit
June 25-27, 1997
Bermuda
703-907-7674

NESDA 47th/ISCET 27th/ and NIAS
5th Annual National Professional
Service Convention and Trade Show
August 4-9, 1997
Las Vegas, NV
817-921-9061

Internationale Funkausstellung/
USA Pavillion
August 30-September 7, 1997
Berlin, Germany
540-372-1414

PSC 97 (Pers. Communications
Industry Association)
September 10-12, 1997
Dallas, TX
703-739-0300

CTIA Breakaway '97
September 18-20, 1997
San Diego, CA
702-268-1818 ext. 310

CES Mexico
October 8-10, 1997
Mexico City Mexico
Sponsored by EIA/CEMA
703-907-7620

ASEA (AZ) Annual State Convention
October 10-12, 1997
Casa Grande, AZ
602-937-3241
e-mail: Lunncet@aol.com

Personal Computer & Electronics Expo
October 16-19, 1997
Uniondale, LI, NY
800-886-8000

Networks Expo Dallas/Windows
World
October 29-31, 1997
Dallas, TX
201-346-1400, ext. 145

TeleCon XVII (ABC/Applied
Business teleCommunications)
November 5-7, 1997
510-606-5150

'98 International Consumer
Electronics Show
January 8-11, 1998
Las Vegas, NV
703-907-7600

Home Automation Show &
Conference
February 25-27, 1998
Orlando, FL
203-840-5482

NESDA 48th/ISCET 28th/NIAS 6th
Annual
August 10-15, 1998
Kissimmee, FL
817-921-9061

PCS 98
September 23-25, 1998
Orlando, FL
703-739-0300

Personal Computer & Electronics
Expo
October 15-18, 1998
Uniondale, NY
800-886-8000
516-889-6000

PCS 99
September 22-24, 1999
New Orleans, LA
703-739-0300

es the PC board to the tuner frame. The cracks usually appear in the prescaler section of the tuner. This problem is easy to confirm. Simply tapping on the tuner with the handle of a screw driver will either cause the problem to appear or cause it to disappear.

Zenith tuner problems

Older Zenith tuners like the 175-2310 and 175-2258 tend to have solder problems as well. These problem solder connections develop around the PC board stakes for Zenith's "famous" plugs. Wiggling the wire or pulling on it often reveals the area of difficulty. I have found that resoldering all these stakes is the best way to correct the problem. Unlike others, these tuners lend themselves to troubleshooting. They can easily be disassembled, hooked up, and probed.

The newer Zenith tuners are directly soldered onto the PC board, and they are a little bit more difficult to troubleshoot. West Tennessee is prone to have serious thunderstorms, and I see a lot of lightning-damaged television sets. These Zenith tuners are tough. Most of the damage I see is confined to the capacitor that routes the signal from the antenna connector to the RF amplifier. A ceramic capacitor in the 15pF to 20pF range is an excellent substitute for the original part. Make sure it has a hefty voltage rating, and do a safety leakage check before you return the set to the customer.

RCA tuners

Some RCA tuners are difficult to repair. Simply getting to the PC board is a chore, and putting the tuner back into the chassis to check it can cause problems because of the tiny traces RCA uses (Check out the CTC 140 and 155/57 chassis!). I have, however, had good luck repairing RCA TV's that use the MTT tuning systems, and there are a lot of those TVs in service.

These MTT modules cause a variety of problems: no turn on, snowy picture (or no picture at all) and distorted audio. a television that turns itself on, and audio that suddenly becomes very loud. All of these symptoms may be intermittent.

The last MTT circuit I worked on exhibited unusual symptoms. The set came on at full volume and no raster when it was plugged in. The problem was two defective electrolytic capacitors. Replacing them cured the problems.

Another set wouldn't turn off. A defective Q601 was the culprit. And then there was the set where the volume (audio) would turn up by itself. Wiggling the wires on the top of the module caused the volume to decrease (or increase). One set of stakes had ringing cracks around them. Resoldering the stakes cured the problem.

As a matter of fact, I have found that in most instances simply resoldering the stakes that the various plugs attach to cures a large percentage of problems caused by this MTT circuit. Therefore, the first thing I always do when servicing one of these sets is resolder the stakes.

Use Figures 5 and 6 as guides to troubleshooting the MTT modules. The voltages listed here are a handy guide for you to use in confirming what you must find for the TV to operate properly.

The "tuner-on-board" sets

Of course, the big tuner issue these days is the new generation of RCA television sets that have the tuner built right onto the circuit board. The technician must either learn how to troubleshoot this tuner or ship the chassis off to be repaired for a fee that usually is around \$120.00. As far as I know, RCA is the only manufacturer that follows this procedure; and, I suspect, for good reason.

In order to implement this type of tuner, RCA had to develop a new circuit board (glass-steel) that had low capacitance, a tuner wrap that had a contraction-expansion rate comparable to the circuit board, and a plastic-based solder to connect the two. RCA now says it has solved the "tuner wrap problem." Maybe. At the very least, other manufacturers have not followed their example.

I will admit that this is one of the most trouble free tuners I have seen to date. I have to except the tuner wrap, but this is not an electronic-based problem. I have seen a chassis that had been hit by a terrific burst of lightning, and the tuner

emerged unscathed. It is a reliable tuner.

But it does cause problems. For example, there was one chassis that had a very snowy picture on all channels. All voltages were present and within specs. As an experiment, I injected an off-the-air signal directly into the gate of transistor Q7102 (the vhf amplifier). The picture cleared up immediately. Inspection of the PC board turned up a break in a trace near the antenna connector.

Another set had almost no picture and very, very noisy audio. Voltage checks revealed no agc voltage on the gate of Q7102. The problem was a solder splash shorting the agc voltage to ground (Figures 7 and 8).

Another set had raster, no video and no audio on any channel in any mode. In this case, the B+ on pin 14 of U7301 (oscillator-mixer) was 7V instead of the specified 9V. I applied 9V from an external supply, and the picture cleared up immediately. When I turned the set off and back on, the same symptoms reappeared. U7301 was defective.

I have seen at least two sets that had no vhf but good uhf. Injecting a vhf signal from a signal generator into pin 4 of U7301 did not clear it up. In both instances replacing this IC put the television in good working order.

Two things will help you service this tuner. The first is logical thinking or common sense. If you have a snowy picture and you inject a good IF signal into the base of the IF amp and the picture clears up, you know you have a tuner problem. If you have good high-band vhf but no low band activity, you will not waste your time working with the rf amp, you will check the band-switching transistors in the tuner.

The second thing that will help you service this tuner is the checking of voltages and resistances. Logical thinking will usually get you to the general area, and a good multimeter will help you locate the defective component.

RCA has some good technical manuals that any tech should have readily available. Check out "CTC 177/87 Troubleshooting Guide" and "CTC 185 Technical Training manual." You can order these directly from Thomson or through your local parts distributor. ■

Accurately Test All CRTs!



CR7000 "BEAM-RITE"
CRT Analyzer & Restorer

**Test All CRTs, Including:
Computer Monitors, Video
Displays, Televisions,
Projection TVs, Scopes, and
special application CRTs—**

- The CR7000 now has full dynamic range to test older CRTs and the new ones
- The most accurate and thorough tests of any tester
- Full bias ranges with a sliding "good/bad" scale
- Exclusive "Lo Level" and "High Level" emission tracking
- Detects all gun element shorts or leakage

We'll prove it!

**Compare the new CR7000
to your current CRT tester.
Call 1-800-SENCORE
for a free 10 day trial.**

SENCORE
3200 Ser core Drive, Sioux Falls, SD 57107
D rect: (605)339-0100 Fax: (605)339-0317



Parts and accessories catalog

Parts Express announced the release of their 244-page, 1997 catalog. Parts Express is a distributor of electronic parts and accessories geared toward the consumer electronics industry and the technical hobbyist.

They stock a variety of raw loud-speaker drivers for home and auto applications, CATV and VCR repair parts, semiconductors, tools and technical aids, home theatre and home automation products, test equipment, computer accessories, chemicals, wire, connectors, instructional books and videotapes, speaker design software, cellular phone accessories, etc.

Circle (31) on Reply Card

Catalog of computer connection products

A new B&B Electronics catalog lists products that provide solutions to common and uncommon computer serial port connection problems. Port mounted interface converters allows users to connect incompatible interfaces and communicate at distances up to 4,000 feet.

A new 5-port smart switch may be daisy-chained to connect up to 17 devices to one serial port. The DB-25 DCE/DTE Port Reverser is new, as are signal conditioning modules for use with K-type thermocouples, pH electrodes, and a variety of bridge type outputs. The

catalog also shows several new communications line protectors including optical isolators, surge protectors and security devices.

Other new products in the 40-page catalog include digital multimeters designed to read low voltage communications line signals. Some have built-in memory and the ability to download to a PC. Three new PCMCIA Cards for parallel, serial, and multiport applications are shown.

Circle (32) on Reply Card



New SPC Catalog

Specialized Products has released its new Spring '97 Catalog. The 368-page publication features an assortment of over 5000 products including everything needed for basic cable installation to board level component repair.

Choose from over 100 standard tool kits designed for installation, field service and repair applications. Tool cases and tool pallets in assorted styles and materials are stocked with name-brand tools. Any standard tool kit may be modified, and for more unique requirements, custom tool kits can be built from scratch to exacting specifications.

SPC offers reusable shipping containers in over 100 configurations plus various other styles. Options include hard-shell, soft-sided, foam-lined and foam-filled cases plus rolling tool chests, cases with wheels and luggage carts.

The company also offers an assortment of electronic test equipment featuring component testers, DMMs, frequency counters, function generators, oscilloscopes, power supplies and more.

Circle (33) on Reply Card

Fax technical support system

Jensen Tools, supplier of tool kits, specialty tools, test equipment, diagnostics, and other related equipment to the electronics industry, announced the operation of their 24-hour FaxBack system as a service for inquirers who need information about products in their catalogs. FaxBack provides the latest catalog pages, detailed technical specifications and special product promotions around-the-clock.

To access the company's FaxBack 24 hours a day, 7 days a week, phone 602-968-6241, ext.271. An easy-to-follow voice prompt guides the caller through the procedure. The requested information will be delivered through the inquirer's fax machine in minutes.

Circle (35) on Reply Card

Test and measurement catalog

Hewlett-Packard announces the 1997 edition of its Test and Measurement Catalog. The publication includes descriptions of more than 1,500 of the company's test and measurement products, systems and services.

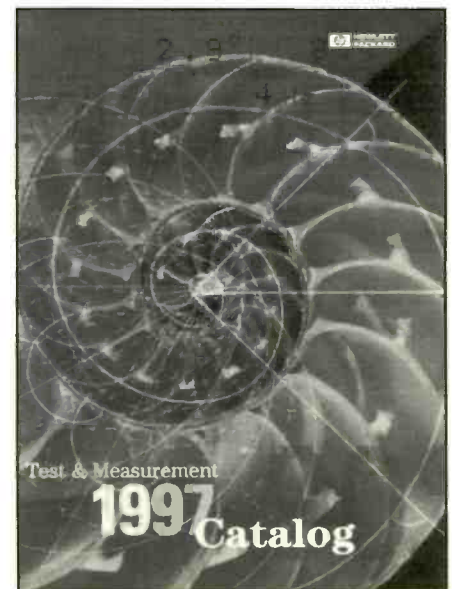

The catalog, which is published annually, provides a fast, convenient source for researching, planning, budgeting and purchasing a broad range of test products and services. Along with descriptions and technical specifications of standard products and systems, the catalog contains: product-comparison charts, tutorial material, indexed lists of application and product notes, outlines of training seminars, and descriptions of other available informational literature, such as newsletters and specialty catalogs.

Circle (36) on Reply Card

Tools web site

CooperTools (the Cooper Hand Tools Division of Cooper Industries, Inc.) offers a variety of information through its Internet web site.

New product information is featured and Material Safety Data Sheets (MSDS) are available. Background information on the company is provided along with customer service numbers and product usage tips. A 20-page booklet containing basic ergonomic information for hand tool users is also available for downloading from the site at <http://www.coopertools.com>.

The website of the parent company can be reached via the Internet at <http://www.cooperindustries.com>.

Circle (37) on Reply Card

Electromechanical relays

A new catalog featuring a full line of electromechanical relays for a wide range of PCB and panel mount applications in general purpose, automotive, and telecommunications products is being offered by GEM Electronics.

The GEM Electromechanical Relays Catalog includes 10 different types of electromechanical relays ranging from 2 to 45 amps for a wide range of application. Featuring a cross-reference guide to other manufacturer's part numbers for each relay, this catalog provides complete technical data sheets and specifications.

To assist designers, the catalog describes general application guidelines such as the method of determining relay specifications, basics of relay handling, problem points with regard to use, con-

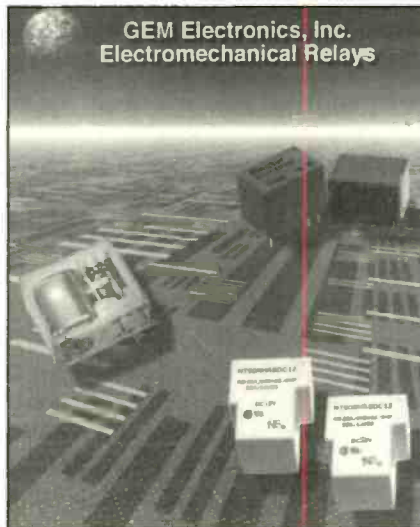

tacts and contact shapes, and more. A relay design guide is also included.

Circle (38) on Reply Card

Epoxy designed for optics and fiber optics

This full color brochure describes how Epoxy Technology addresses the adhesive requirements in the optical and fiber optic industries.

The brochure explains the areas in which these products fulfill the bonding, coating and encapsulating needs for fiber optic communication networks. In addition to telecommunications, these adhesives are also applicable for use in assembly or manufacture of medical devices, lasers, optical filters, beam splitters, LED's, photo diodes, prisms and lenses.

Circle (39) on Reply Card

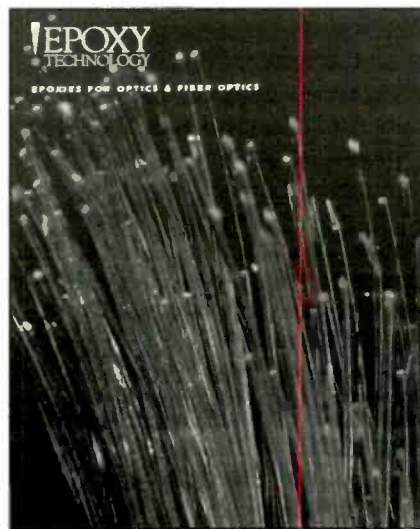

Easily Test And Restore CRTs!



CR7000 "BEAM-RITE"™
CRT Analyzer & Restorer

Easily Test And Restore CRTs With The Most Complete Tests Available For Added Profit And Security!

The Easiest To Use CRT Tester On The Market – Guaranteed

- Simply connect one of the six supplied adapters to test virtually all new CRTs without adjusting setup switches
- All three guns of color CRTs are tested, and results displayed, simultaneously
- All gun tests are displayed with interpretation-free "Good/Bad" results

We'll prove it!

Compare the new CR7000 to your current CRT tester. Call 1-800-SENCORE for a free 10 day trial.

SENCORE

3200 Sencore Drive, Sioux Falls, SD 57107
Direct: (605)339-0100 Fax: (605)339-0317

Circle (75) on Reply Card

Identifying circuit components

By Victor Meeldijk

Often, when schematics are not available, or when trying to locate a part from a schematic; logos, component part number styles and prefixes can be used to identify the device manufacturer. We provide some of that information in this article.

In repairing, or designing systems with existing hardware, the engineer or technician often has to work without detailed data. Often troubleshooting, or interface designs, are reverse engineered using component data, or block diagrams that only list part numbers. Manufacturer Logos and part numbers are often the only details available.

The list is a guide to help in identifying components from prefixes and logos. The list also contains cross references to enable the user to find companies after mergers, acquisitions and name changes.

Here's the list

A prefix, see Actel Corp., Allegro Microsystems, Inc., Harris Semiconductor (custom part), EM Microelectronic (real time clocks, voltage regulators and microprocessor surveillance ICs)

ABTE prefix, see Texas Instruments

ACH prefix, see Harris Semiconductor (custom part)

ACS logic (and prefix), see Harris Semiconductor

ACT prefix, see Texas Instruments (if ACT-S-XXXXXXX-XXXXXX see Aeroflex Circuit Technology Corporation)

AD prefix, see Analog Devices

ADC prefix, see Thaler Corporation, Analogic Corporation, Datel, Inc., National Semiconductor, Burr-Brown Corp.

AHE, AHF prefix, see Lambda Advanced Analog (DC/DC converters)

AM prefix, see AMD (Advanced Micro Devices), Datel Inc., Harris Semiconductor (custom part), M/A-COM Inc., Anzac, Ascom Microelectronics

AMA prefix, see GEC Plessey (Marconi Circuit Technology Inc.)

AN logo, see Adaptive Networks

AN prefix, see Matsushita (Panasonic), the AN is for linear (analog) IC's., AuraVision Corp.

B logo, see Bourns, Inc.

B prefix, see NEC (ECL SRAMs)

BA prefix, Bus Logic, National Semiconductor (ECL gate array), American Bright Optoelectronics Corporation (LED BRT) (bar graph and array displays). BA prefixed Japanese (generic linear devices such as operational amplifiers and comparators) devices are made by various manufacturers including Panasonic and Rohm.

BC prefix, (bipolar transistors or ECL gate array), see Motorola, National Semiconductor (gate array), Zetex (transistors), AVG Semiconductor (second source transistors), American Bright Optoelectronics Corporation (LED BRT) (clock displays)

BF prefix, (ECL gate array and transistors), see Motorola, National Semiconductor (gate array), Zetex (transistors), AVG Semiconductor (second source transistors)

BI prefix, see BI Technologies

bq suffix, see Benchmark Microelectronics

BR prefix, see Rohm (memory ICs), Gentron, Corp. (solid state relays), American Bright Optoelectronics Corporation (LED BRT) (resistor led)

BS prefix, see Motorola, Zetex

Bt prefix, see Brooktree Corporation, and for triacs see Philips Components, Discrete Products Division C prefix, see Crystal Semiconductor, Space Power Electronics, Inc.

C4 part number, TC4 series of parts by Toshiba (single gate logic devices electrically equivalent to 4000B (the Toshiba TC4SXX or C4), and 74HC logic devices (the Toshiba TC7SXX or C7)

CA prefix, see Harris Semiconductor (formerly RCA), National Semiconductor (custom part), Motorola, Tundra Semiconductor

Capacitor in series with a resistor logic symbol logo, see Connor-Winfield Corporation (crystal oscillators)

CD prefix, formerly RCA now Harris Semiconductor (also see National Semiconductor), Pioneer New Media Technologies, Inc., Clarkspur Design (DSP ICs), Cirrus Logic (see also LG Semicon (formerly GoldStar Technology, Inc.) for 4000B CMOS ICs), Philips Semiconductors (custom part)

cdi, see Conversion Devices, Inc.

Chips, see Chips and Technologies

Meeldijk is Reliability/Maintainability Engineering Manager, Diagnostic/Retrieval Systems, Inc. Oakland, NJ 07436.

- CJSE prefix**, see Solitron
- CL prefix**, see Cirrus Logic and C Cube Microsystems (some MPEG devices second sourced by Texas Instruments and Advanced Micro Devices), AVG Semiconductors (second source VGA graphics parts), Crosslink Semiconductor (SRAMs)
- Clairex Electronics** (Mount Vernon NY), see Clarostat Sensors and Controls.
- CMD**, see California Micro Devices.
- COM prefix**, see Standard Microsystems Corporation
- COP prefix**, see National Semiconductor
- CSC**, see Cherry Semiconductor
- CXD or G or X prefix**, see Sony Semiconductor, Harris Semiconductor
- D prefix**, see Intel, NEC, Destiny Technology (laser printer chip sets), Siliconix, Dionics, Inc., Point Nine Technologies (RF units), Frequency Devices, Inc. (filters); DSP Communications, Inc. (DSP based voice control processor), M/A-Com (GaAs MMIC mixers), Harris Semiconductor (unijunction transistors), AVG Semiconductors (second source some devices), Durel Corporation (EL lamps and driver ICs).
- Two "D"'s back to back** (with the tail of the "D"'s forming a circle around them), see Datatronics
- DA prefix**, see Apex Microtechnology, GEC Plessey, SGS-Thomson (diode arrays)
- DAC prefix**, see Analog Devices, Datal Inc., Burr-Brown Corp., Motorola, and National Semiconductor
- DEC**, see Digital Equipment Company
- DII**, diode bridges sold by Mallory, North American Capacitor Company
- DM prefix**, see National Semiconductor, Seeq Technology, Inc., Ramtron International Corp.
- EF prefix**, see Thompson Components and Tubes Corporation, National Semiconductor (custom part)
- EG&G Frequency Products**, see CINOX Corporation
- EH prefix**, see Elantec, Inc.
- EIC logo**, see Electronics Industry (USA) Co. Ltd.
- EL prefix**, see Elantec, Inc. and Planar Systems, Inc. (for flat panel displays), Elmos GmbH
- Electronic Arrays**, see NEC Microelectronics (consumer IC's including clock IC's and programmable parts)
- ELH**, see Elantec' (see also National Semiconductor for LH parts)
- EPB prefix**, see Altera Corp.
- EPC prefix**, see Altera Corp., Allied Electronics GmbH (encoder pulse converter)
- EPF prefix**, see Altera Corp.
- EPM prefix**, see Altera Corporation and Texas Instruments
- EPS prefix**, see Altera Corp.
- ERG logo**, see Endicott Research Group
- ET prefix**, see Tseng Labs, Inc., Edge Technology, Eteq Microsystems, Inc., Elytone Electronics Co., Ltd. (magnetics)
- F between a top and bottom bar logo**, see Fujitsu
- F prefix**, see National Semiconductor (Fairchild Semiconductor), FOX Electronics (crystal oscillators), AVG Semiconductors (second source some ICs)
- FDC prefix**, see Standard Microsystems Corp. (floppy disc controller)
- G logo** (with an arrow on the inside of the "G"), see Germanium Power Devices
- G prefix**, see GTE, Harris Semiconductor (custom part), Loral Corporation (used in their equipment), National Semiconductor (if G16V8, 20V8, 22CV10, 22V10, discontinued, see Atmel, Lattice, Cypress Semi., TriQuint Semi., AVG Semiconductors (second source video DAC), Seiko Instruments (LCD module))
- GAL prefix**, see Lattice Semiconductor Corp.
- Gazelle** see TriQuint Semiconductor, Inc.
- GBL**, see (GigaBit Logic) TriQuint Semiconductor
- GD prefix**, see Cirrus Logic, LG Semicon (formerly GoldStar Technology, Inc.)
- GE** - General Electric Semiconductor for OEM devices, see Harris Corporation for generic replacement devices, see Thomson Consumer Electronics
- GI**, see General Instrument
- GLC prefix**, see LG Semicon (formerly GoldStar Technology, Inc.)

- GLX prefix**, see Vitesse Semiconductor (GaAs gate arrays)
- GMS prefix**, see LG Semicon
- GPD**, see Germanium Power Devices
- H logo**, see Hi-Sincerity Microelectronics Corp.
- H prefix**, see SGS-Thompson Microelectronics, Quality Technologies (phototransistor optocouplers), EM Microelectronic (watch and clock ICs, watchdog timers, smart reset ICs), National Semiconductor
- H on top of a V logo**, see High Voltage Semiconductor Specialists, Inc.
- H4C prefix**, see Motorola (programmable ASICs)
- H8/ prefix**, see Hitachi America Ltd.
- HA prefix**, see Harris Semiconductor and Hitachi Semiconductor (devices are not related to each other, i.e., not second sources.)
- HB prefix**, see Hitachi Semiconductor
- HCMP prefix**, see Signal Processing Technologies, Inc. (comparators)
- HCPL-XXXX part number**, see Hewlett-Packard, Quality Technologies
- HD prefix**, see Hitachi Semiconductor, Siemens, and Natal Engineering Co, Inc. (Digital to Synchro converters), Zetex
- HDK Logo**, see Hokuriku Electric Industry Co., Ltd.
- HDM prefix**, see Hyundai Electronics America (Hyundai Digital Media Division is now Odeum Microsystems, Inc.), Watkins- Johnson
- HDMP prefix**, see Hewlett-Packard
- HI prefix**, see Harris Semiconductor, Burr-Brown Corp. and Holt Integrated Circuits, Inc.
- HLMP prefix**, see Quality Technologies, Siemens (light bars- discontinued)
- HSP prefix**, see Harris Semiconductor
- i logo and prefix**, see Intel Corp.
- ICD prefix**, see IC Designs
- ICS**, see Integrated Circuit Systems, Integrated Component Systems, Inc. (crystals and crystal oscillators)
- ICL prefix**, formerly Intersil, see Harris Semiconductor
- IDI**, see Industrial Power and if LEDs, or lamps see Industrial Devices, Inc.
- IDT**, (also part prefix) see Integrated Device Technology, Inc.
- IIT**, see 8x8 Inc. (formerly Integrated Information Technology, Inc.)
- IMP prefix**, see IMP, Inc. (International Microelectronic Products, Inc.)
- Integrated CMOS Systems**, became Vertex Semiconductor and now merged into Toshiba.
- International CMOS Technology**, now ICT
- Intersil**, see Harris Corporation
- JAN, JANTX, JANTXV prefix**, this denotes a semiconductor qualified to U.S. military standard MIL-S-19500.
- JFW**, see JFW Industries, Inc.
- JM prefix**, see GEC Plessey (Marconi Circuit Technology, Inc.)
- JM38510 prefix**, this denotes a part qualified to U.S. military standard MIL-M-38510.
- JRC**, see NJR Corporation (a subsidiary of New Japan Radio Company, Ltd.)
- K prefix**, see Silicon Systems and (for K-XXXX part numbers) Optek Technology, Inc., Champion Technologies (oscillators), AVX Corporation (oscillators), OKI Semiconductor, Krypton Isolation, Inc., AVG Semiconductor (second source gate arrays). Note: "K" prefix on a semiconductor, such as KN2222, indicates part manufactured in Korea.
- KA prefix**, see Samsung Semiconductor, AVG Semiconductor (second source gate arrays, microwave diodes, etc.)
- KE prefix**, see Optek Technology, Inc., Kawasaki (Steel) LSI, USA, Inc.
- KMZ prefix**, see Philips Semiconductor
- KRC prefix**, a prefix typical of semiconductors made in Taiwan vs the 2SC part made by Japanese manufacturers.
- KS prefix**, see Samsung Semiconductor, Optek Technology, Inc., AVG Semiconductors (second source telephone ICs)
- L4C, 7C, 10, 21, 29 prefix**, see Logic Devices, Inc.
- L41 series**, see Frederick Components International Ltd.

AMS

ADVANCED MICRO SYSTEMS, INC.



Aromat Corporation

AKMASAHI KASEI
MICROSYSTEMS CO., LTD.

BENCHMARK



CIRRUS LOGIC



CYPRESS

California
Micro Devices

DATATRONICS, INC.

ERICSSON

EXAR

Elmwood
SensorsGeneral
Semiconductor
Industries, Inc.Harris
SemiconductorHI-SINCERITY
MICROELECTRONICS CORP.

HOKURIKU

Japan Radio
Corporation

Kawasaki LSI

Microchip
Technology

Micro Linear Corp.

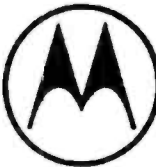
Micro Power
Systems

Motorola



NS



National Semiconductor



NEWBRIDGE

Newbridge Microsystems
Now Tundra
Semiconductor

POWER TRENDS



QUICKLOGIC

RHOMBUS
INDUSTRIES INC.SGS-THOMSON
MICROELECTRONICSSYNERGY
SEMICONDUCTOR

SIERRA SEMICONDUCTOR

PARTS

ELECTRONIC PARTS EXPRESS

Reg. \$149.95
SPECIAL
\$129.95
Order
#ES-390-706**Computer
Monitor Tester**

This compact device can quickly and easily troubleshoot, test, and align computer monitors, without the need for a separate computer. Test MDA, CGA, EGA, VGA (640 x 480), SVGA (800 x 600), 8514 (interlaced), SVGA (1024 x 768), and high resolution monitors. Generates the following video test patterns: color bars, cross hatch, dots, color raster (white, red, green, blue), and windows. Two video connectors are provided: a digital/TTL 9 pin and an analog 15 pin. Net weight: 3/4 lb.

CALL TOLL FREE: **1-800-338-0531**To receive our 244 page full line catalog, use source code **ESM** when ordering.340 E. FIRST STREET, DAYTON, OHIO 45402-1257
PHONE: 937-222-0173 FAX: 937-222-4644
E-MAIL: sales@parts-express.com
HOME PAGE: <http://www.parts-express.com>

Circle (70) on Reply Card

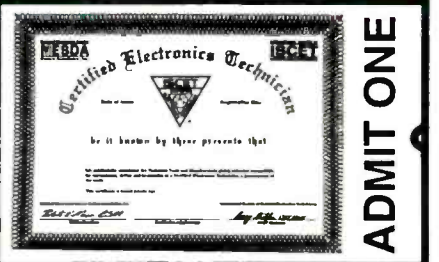

ADMIT ONE

**Your Ticket to
SUCCESS**

More than 40,000 technicians have gained admittance worldwide as certified professionals. Let your ticket start opening doors for you. ISCET offers Journeyman certification in Consumer Electronics, Industrial, Medical, Communications, Radar, Computer and Video. For more information, contact the International Society of Certified Electronics Technicians, 2708 West Berry Street Fort Worth TX 76109; (817) 921-9101

Name _____

Address _____

City _____

State _____ Zip _____

Send material about ISCET and becoming certified

Send one "Study Guide for the Associate Level CET Test."

Enclosed is \$10 (inc. postage).

These are some of the logos of component manufacturers, accompanied by the name of the manufacturers.

LAS prefix, see Semtech Corpus Christie (formerly Lambda Semiconductor)

LB prefix, see Hitachi Semiconductor (SONET devices), Siemens

LBC logic family, see Texas Instruments

LC prefix, see Gennum Corporation, Semtech Corp. (transient voltage suppression diodes)

LCA prefix, see LSI Logic (programmable ASICs)

LCB prefix, see LSI Logic (programmable ASICs)

LCP prefix, see SGS-Thomson Microelectronics

LCX logic (3.3 volts CMOS low voltage logic with tolerance to 5V on inputs and outputs), Motorola, National Semiconductor, Quality Semiconductor and Toshiba

LCX prefix, LCD displays, see Sony Electronics, Inc.

LD prefix, see Gennum Corporation, Siemens, Silicon Logic, Inc.

LF prefix, see National Semiconductor, Logic Devices, Inc.

LG, LGB, G, H, K, S, T, Z prefix, see Siemens

LH prefix, see National Semiconductor (note an ELH prefix is used by Elantec[®], who second sources some National Semiconductor parts, see also MICRA Corp. for another second source of some National Semiconductor parts.), Sharp (used for SRAM's) and for LH-X part numbers see KDI/triangle Electronics, Inc., Siemens

LUH prefix, see Siemens LVC logic, see Philips Semiconductor

LX prefix, see SenSym, Inc., Linfinity Microelectronics, Inc.

LY, LYB, K, T, U, Z prefix, see Siemens

M38510/XXXXXXXX part number, indicates a part qualified to MIL-M-38510 military specification. All the slash sheets (i.e., individual devices covered by slash sheets to this drawing) are inactive and are not to be used for new designs. MIL-M-38510 has been replaced by MIL-PRF-38535.

M prefix, see Mitsubishi Electronics America, Inc., Hughes Semiconductor Products Center, Valtronic USA, Inc. (CMOS SRAM modules), TranSwitch Corp., SGS-Thomson Microelectronics, and ALI - Acer Laboratories, Inc. (Pacific Technologies Group); Micronetics (VCOs), AVG Semiconductors (second source some ICs), Optical Imaging Systems, Inc. (LCD displays), EM Microelectronic (display drivers, real time clocks), Motorola

M5M prefix, see Mitsubishi

MA prefix, see Matsushita (Panasonic), GEC Plessey (Marconi Circuit Technology, Inc.), M/A-Com, Analog Systems

MACH prefix, see Advanced Micro Devices (AMD)

MB prefix, see Fujitsu, Mitel Semiconductor, Analog Systems

MBR prefix, see Motorola (schottky barrier rectifiers)

MBM prefix, see Fujitsu

MC logo, see Micro Crystal (crystals and oscillators)

MC prefix, see Motorola, Inc., Performance Motion Devices, MICRA Corporation (second sources some National Semiconductor parts), IBM (microcontrollers), Texas Instruments (second source), Intel, Watkins-Johnson, Analog Systems, Standard Microsystems Corp. (IBM PS/2 microchannel bus interface), AVG Semiconductors (second source telephone and interface, etc. ICs)

MCE logo, see Magnetic Circuit Elements, Inc. (small magnetics)

MCM prefix, see Motorola, Inc., National Semiconductor

MD prefix, see Intel Corp., Mitel Semiconductor, Harris Semiconductor (usually a custom part)

MN prefix, see Micro Networks (a division of Unitrode), Matsushita (Panasonic) Note: devices not equivalent, Micronetics (crystal oscillators)

MM prefix, see National Semiconductor, and if MM(number)(letter)-XXXXX-XXXXX see Matra-MHS, Analog Systems, ATI Technologies (MPEG ICs)

MMBT, MNBTA, MMBTH, MMBV prefix, transistors, see ROHM Electronics Division, Motorola Semiconductor Products

MVAM prefix, see Motorola

MX logo, see Macronix, Inc.

MX prefix, see Maxim Integrated Products, MX-Com Inc., Macronix Inc., Datel Inc., SZE Microelectronics GmbH

N prefix, see Philips Semiconductors (Signetics)

NXX part number, see Hewlett-Packard Co. (RF ICs)

NJL, NJM, NJU prefix, see New Japan Radio Company, Ltd. and NJR Corporation

NJR Corporation, see New Japan Radio Company, Ltd.

NS prefix, see National Semiconductor, Nova Engineering, Inc. (frequency synthesizer modules)

NSC prefix, see National Semiconductor

Oak, see OTI, Oak Technology, Inc.

OBG prefix, see Siemens (bar graph displays, discontinued)

OCP prefix, see Matsushita (Panasonic)

OEi, see Optical Electronics, Inc.

OF prefix, see Phillips

OFC logo (the "O" has 3 wavy lines through it, see Oak Frequency Control Group)

OHN, OHS prefix, see Optek Technology, Inc.

OM prefix, see Matsushita (Panasonic), Philips Semiconductors, Omnirel Corp. (power MOSFETS, voltage regulators)

OMA, OMC, OMD prefix, see Omnirel Corp. (operational amplifiers, similar to OPA prefixed devices)

ON prefix, see Harris Semiconductor (custom part)

OP prefix, see Analog Devices (and Linear Technology, Maxim, and National Semiconductor that second source some parts). Also see Optek Technology, Inc.

OPA prefix, see Burr-Brown Corp.

OPT logo, see OPT Industries, Inc.

OPT prefix, see Burr-Brown, Optimum Semiconductor

OptoSwitch, Inc.- see Clarostat Sensors and Controls

Optron Products (or TRW Oprton), see Optek Technology

OW prefix, see Advanced Data Technology

P4 prefix, see Performance Semiconductor Corp.

P54C, a 3.3 version of the Intel Pentium Microprocessor

P82 prefix, see Chips and Technologies

PA prefix, see Apex Microtechnology Corp., and Hewlett Packard (microprocessor IC's), Hitachi (RISC microprocessors), Unisys Corporation (ASICs), ICT (PLDs)

PAC prefix, PAC is trademark of Waferscale Integration, Inc. (Programmable standAlone microController)

PAL, PALCE prefix, see AMD

pASIC prefix, see Cypress Semiconductor (FPGAs)

PC prefix, see National Semiconductor, Harris Semiconductor (custom part), CMD Technology, Inc. (PCI to IDE controller IC), ICT, Inc. (stereo enhancement processor), Powertip Technology Corporation (LCDs)

PCA, PCD, PCF prefix, see Philips Semiconductor (formerly Signetics), AVG Semiconductors (second source some ICs)

PCM prefix, see Burr-Brown, National Semiconductor (PCMCIA interface ICs)

PEEL prefix, see ICT, Inc.

PH, PHD prefix- see Philips Semiconductors (Signetics)

PIC prefix, see MicroChip Technology, Pericom, Inc. (transceivers for token ring networks)

PLD prefix, see Cypress Semiconductor Optical Communication Products, Inc.

pLSI prefix, see Lattice Semiconductor Corporation

Q prefix, see Quality Semiconductor, Inc, and Qualcomm, Inc.

QB prefix, see QBAR Tech, Inc.

QBH prefix, see Q-bit Corporation

QC prefix, GEC Plessey (crystal oscillators)

QHY prefix, see Chip Express (ASICs)

QL prefix, see QuickLogic Corp.

QLS prefix, see Triquint Semiconductor

QR prefix, see National Semiconductor

QRB prefix, see Quality Technologies, Corporation

QRM prefix, see TRM, Inc.

QSI prefix, see Quality Semiconductor, Inc.

QTLP prefix, see QT Optoelectronics

QT prefix, for crystal oscillators/crystals, see Q-Tech Corp., Quality Thermistor, Inc. (thermistors)

R prefix, see Rockwell International Corp., Raytheon Semiconductor (PROM's), Integrated Device Technology (IDT) (microprocessors), Radisys Corporation, Toshiba (RISC processors), Isotek Corporation (surface mount resistors)

- RXX part number** (on SOT transistor), see Rohm
- RXXXCHx part number**, see Westcode Semiconductors
- R4 part number**, see Toko America, Inc.
- RAY prefix**, see Raytheon Semiconductor
- RBG-XXX part number**, see Siemens (bar graph displays, discontinued)
- RC prefix**, see Raytheon Co. and Rockwell International Corporation
- RCA for OEM devices**, see Harris Corporation for generic replacement devices (SK series), see Thomson
- RCC prefix**, see Raytheon Co.
- RCV prefix**, see Hitachi Semiconductor (SONET devices), Rockwell (modem IC)
- RCM prefix**, see Rohm Corp. (LCD displays)
- RD prefix**, see Ricoh Corp.
- RDC-XXXXX part number**, see ILC Data Device Corp.
- REF prefix**, see Analog Devices (and also Linear Technology, Burr-Brown Corp., GEC Plessey, and Raytheon that second sources some of these voltage references.)
- REG prefix**, see Burr-Brown
- RF5 prefix**, see Ricoh Corporation (dc/dc converters, power supplies)
- RFM logo**, see RF Monolithics, Inc.
- RFMD**, see RF Micro-Devices, Inc.
- RGB prefix**, see IBM Microelectronics
- RH prefix**, see Actel Corporation (radiation hardened ICs), Honeywell Space Systems (radiation hardened ICs)
- RH5 prefix**, see Ricoh Corporation (switching regulators, dc/dc converters)
- RTX prefix**, see Harris Semiconductor
- RX5 prefix**, see Ricoh Corp. (voltage regulators)
- RXT prefix**, transistors, see ROHM Electronics Division
- S logo**, see Simtek Corp., Staktek Corp. (for memory stacked modules)
- S+M logo**, see Siemens Components, Inc.
- S prefix**, see American MicroSystems (AMI), AMCC Applied Micro Circuits Corp., Philips Semiconductor, ISA Jobin Yvon-Spex (Spex Industries) (CCDs), GHz Technology, Inc. (microwave transistors)
- S-part number prefix**, see Seiko Instruments
- “S” with a diode symbol in the middle of the “S”**, see Taiwan Semiconductor Co. Ltd.
- SGS**, see SGS-Thomson
- SIS logo**, see Silicon Integrated Systems, Corp.
- SIS logo**, see SIS Microelectronics, Inc. (the dot over the “i” is made up of 3 lines)
- T in a 6 sided polygon**, see Toyocom U.S.A. Inc.
- T prefix**, see see Lucent Technologies (formerly AT&T Microelectronics)
- T3D prefix**, see Trident Microsystems
- T5**, see MIPS Technologies, Inc. (microprocessor)
- TAA prefix**, see SGS-Thomson Microelectronics
- TAC prefix**, see Raytheon Semiconductor
- TI**, see Texas Instruments
- TFB, TGB, TGC, TGE prefix**, see Texas Instruments
- TOLD prefix**, see Toshiba America Electronic Components (laser diodes)
- TOTX prefix**, see Toshiba America Electronic Components, Inc.
- TRM prefix**, see Hitachi Semiconductor (SONET devices), Tekram Technology
- TRT in a circle logo**, Tohritsu Co., see RO Associates
- TRU prefix**, see see Lucent Technologies (formerly AT&T Microelectronics)
- TRV prefix**, see Hitachi Semiconductor (SONET devices)
- TST-XXXX part number**, see Beta Transformer Technology, Corp.
- TTLP prefix**, see Technitrol, Inc.
- TWD prefix**, see Amplifonix

Two in a circle logo. see Allegro Microsystems for IC's and transistors (for capacitors contact United Chemi-con and Vishay Sprague).

TWR prefix, see Datel, Inc.

TXC-XXXXX part number. see TranSwitch Corporation

U prefix, see InterFet Corporation (for FET devices), Temic Semiconductors (Telefunken), Mikroelektronik Dresden GmbH

U underlined, see Unitrode

U over a T in a circle logo, see Uni-Tran Semiconductor Corp.

UC prefix, see Unitrode, some devices second sourced by Astec Semiconductor

UCC prefix, see Unitrode integrated Circuits Corporation

UNR prefix, see Datel, Inc.

UPA prefix, see Datel, Inc., NEC (California Eastern labs)-for dual transistor arrays

uPB, uPC prefix, see NEC, Inc.

uPD prefix, see NEC, Inc., AVG Semiconductors (second source some ICs)

uPF prefix, see NEC, Inc.

UR prefix, see USAR Systems, Inc.

US prefix, on vacuum fluorescent displays (VFD's), see Futaba

VB prefix, see SGS-Thomson Microelectronics

VCA prefix, see Burr-Brown Corp.

VL prefix, see VLSI Technology, Inc. and VLSI Technology Inquiries, Opti, Inc.

V-L. see Varitronix, Ltd.

VL Electronics, Inc., see Varitronix, Ltd.

VLC prefix, see Third Domain, Inc.

VY prefix, see VLSI Technology, Inc.

W prefix, see see Lucent Technologies (formerly AT&T Microelectronics), Tseng Labs, IC Works, Inc., Wacom Technology, Corp., Winbond Electronics Corp.

W, underlined, in a circle logo, see Westinghouse Electric Corporation

W, under a dot with two lighting bolts (logo), see Wickman (fuses)

W32 prefix, see Tseng Laboratories, Inc.

WD, WDC prefix, see Western Digital

WDC within a circle logo, see (The) Western Design Center, Inc.

"WE-" prefix, see White Microelectronics

WEDSP prefix. see see Lucent Technologies (formerly AT&T Microelectronics)

WJ logo, see Watkins-Johnson

WLT-XXXX part number, see Wireless Logic Inc.

WM prefix, see Wolfson Microelectronics

X prefix, see Xicor, Philips Semiconductor (custom part), TSC America (motor motion control IC), Harris Semiconductor (custom part), Kyopal C. Ltd.

XC prefix, see Xilinx Inc. (and Motorola if Digital Signal Processor)

XXXXX/BEAJC, or /BEBJC, or similar part number suffix, see Motorola

XE prefix, see XECOM

YBG prefix, see Siemens

YGV prefix, see Yamaha Systems Technology, Inc.

YL prefix, see Siemens

YM prefix, see Yamaha Systems Technology

Z prefix, see Zilog, Inc. and Synertek (that second sources some products), Advanced Micro Devices, Zyrel, Inc. (SRAMS); Omron Electronics, Inc. (displacement sensors).

ZC prefix, see Zetex

Z-Comm logo, see Z-Communications ZDT, ZDX prefix, see Zetex

ZNA prefix, see GEC Plessey

ZPSD prefix, see WSI Inc.

ZR prefix, see Zoran Corp., Zetex Corp.

ZS, ZT, ZTX, ZVC, ZVN, ZVP prefix, see Zetex

Note: This information was extracted from the Author's "Component Identifier and Sourcebook", published by Prompt Publications (H.W.Sams). ■

What Do You Know About Electronics?

The problem and the detailed solution

By J. A. Sam Wilson

In the Buyer's Guide issue of **ES&T** I proposed a basic box problem. I have repeated it here. You have a black box with interconnected resistors inside. You cannot see inside the box, but, you know some things about it. See Figure 1.

You are supposed to design a circuit with three resistors that can be used to replace the black box. When your circuit is installed it will not produce any changes in the external circuitry.

- B and D are shorted together.
- You can make measurements with an ohmmeter, but not across the box.

- All of the resistors inside the box are linear and bilateral.

Since it was a classic black box problem I did not mention all of those things. My error.

The measurements you make are shown in Figure 2.

R_{AB} : The input resistance with the output terminals open.

R'_{AB} : The input resistance with the output terminals shorted.

R_{CD} : The output with the input terminals open.

R'_{CD} : The output resistance with the input terminals shorted.

You have four knowns (the resistance measurements) and three unknowns (the resistor values in the replacement circuit you are going to use). One thing you don't want to try is solving four equations and three unknowns. In some rare cases there is a solution but most of the time it will be a waste of time. So, we will ignore the R'_{CD} measurement.

Here are the three equations we have:

Equation 1: The input resistance with the output terminals open.

$$R_{AB} = R_1 + R_2$$

Equation 2: The input resistance with the output terminals shorted:

$$R'_{AB} = R_1 + \frac{R_2 R_3}{R_2 + R_3}$$

Equation 3: The output resistance with the input terminals shorted:

$$R_{CD} = R_2 + R_3$$

We now have the required three equations and three unknowns. We will solve Equation 1 for R_1 and Equation 3 for R_2 . Why do we want to do that? Because when we substitute those equations into Equation 2 we will get one equation with one unknown (R_3). That can be solved.

Equation 4:

$$R_1 = (R_{AB} - R_3) \text{ [Subtract } R_3 \text{ from both sides of Equation 1]}$$

Equation 5:

$$R_2 = (R_{CD} - R_3) \text{ [Subtract } R_3 \text{ from both sides of Equation 3]}$$

Now we substitute $(R_{AB} - R_3)$ for R_1 , and, $(R_{CD} - R_3)$ for R_2 into equation 2. Here is Equation 2 after the substitution:

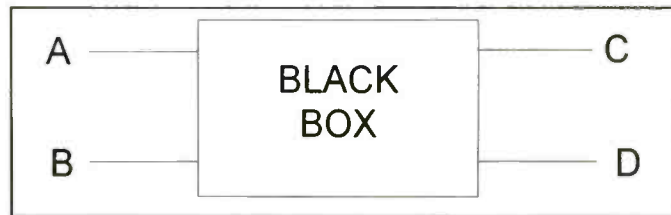

Figure 1. This black box contains interconnected linear, bilateral, resistors. Points B and D are shorted together. Can you measure the resistances between A and B and between C and D and design a circuit that will provide the same resistances?

$$R'_{AB} = \frac{(R_{AB} - R_3) R_{CD}}{R_{CD}} + \frac{(R_{CD} - R_3) R_3}{R_{CD}}$$

Multiply both sides of the equation by R_{CD} :

$$R'_{AB} R_{CD} = (R_{AB} - R_3) R_{CD} + (R_{CD} - R_3) R_3$$

Expand by removing parentheses:

$$R'_{AB} R_{CD} = R_{AB} R_{CD} - R_3 R_{CD} + R_3 R_{CD} - R_3^2$$

Cancel $R_3 R_{CD}$'s. Then, subtract $R_{AB} R_{CD}$ from both sides of the equation:

$$R'_{AB} R_{CD} - R_{AB} R_{CD} = -R_3^2$$

Multiply both sides of the equation by (-1) and take the square root of both sides of the equation:

$$R_3 = \sqrt{R'_{AB} R_{CD} - R_{AB} R_{CD}}$$

After you solve for R_3 you can go to Equations 1 and 3 and solve for R_1 and R_2 .

The best laid plans are often put in boxes

In the article, I said that I would send a solution to the above problem if the reader would send a request and a stamp. I put the letters from readers in a special place where they couldn't get lost. When I recently moved, the movers found them and put them in one of 42 unmarked boxes. When I find the letters I will send the readers' stamps back.

Did I mention that I now have a house to use as an office? Now I have enough room for all of my books and files. Some of the things I have had packed away for years will show up in the near future in WDYKAE? and TYEK.

Transducers

Anyway, I did read the letters but I did not memorize the names and addresses. One of the letters said I could simplify my explanation of transducers by pointing out that "a transducer converts energy from one form to another". That is exactly the thing I did not want to say. I know that that definition has appeared for many years in technical books and articles, but it is not exactly correct.

Let's use a speaker as an example. Electrical energy goes in and sound energy comes out. To a casual observer it looks like

Wilson is the electronics theory consultant for **ES&T**.

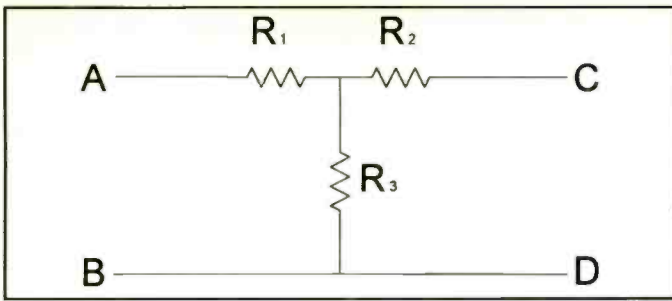

Figure 2. You can replace the black box of Figure 1 with this circuit. The calculations in the text show how to determine the values of resistors R_1 , R_2 and R_3 .

the speaker “converted” energy from one form to another. However, there is nothing in the construction of a speaker that permits energy conversion.

The technically correct explanation is that a transducer is a device that allows the energy of one system to control the energy of another system. The speaker, then, is a control device.

No, I didn't make that up in my head. It is in a book by a man who really knows about transducers. That book is in one of 42 boxes. As soon as it emerges to the surface I will give you the details. In the meantime, it is something to discuss with your friends in your next organization meeting.

Transformers

In my article I cautioned readers to be careful when using the transformer equation:

$$\frac{N_P}{N_S} = \frac{I_S}{I_P}$$

That equation shows you the capability of the transformer; wire sizes permitting. You do not automatically get the secondary current indicated by solving the equation.

A reader wrote to me saying that I forgot to mention other important things like impedance matching. (Remember the boxes full of technical books!)

Actually, I could write a book on transformers. However, the subject was transformer secondary current and I have summarized the meaning of the article above.

Both of the readers I mention in this article are highly-intelligent people. As sometimes happens, writer and reader get into a different frame of reference. Both readers clearly stated their ideas without taking shots at my family heritage. Most of my readers write intelligent letters about real and/or imagined differences. Many, many thanks for your letters—all of you.

To the reader who wrote and said my ideas are too far out: The house in which my office is located is so far out in the country the sun sets between me and town. So, in the future my ideas will definitely be far out.

Did you know?

Did you know that the first dipole antenna entered the communications scene in 1900? Also, the first loop antenna came on the scene in 1935.

Did you know that a gas diode is called a phanotron?

Did you know that the value of ϵ (epsilon) is calculated from an equation that comes from the banking industry?

$$\epsilon = (1 + 1/n)^n$$

Here it is to 15 decimal places: $\epsilon = 2.718281828459045$

To get that number use $n = 1,000,000$. ■

Test Your Electronics Knowledge

By J.A. Sam Wilson

1. A linear measurement of sound intensity, not how it sounds to a human, is called a _____.
2. A non-linear measurement of sound intensity that is related to the intensity as perceived by a human is called a _____.
3. What waveforms, delivered to an oscilloscope, are required to make a circle?
4. Can you calculate the frequency of the third harmonic of a pure sine wave having a frequency of 380Hz?
5. The famous Simpson 260 meter has a rating of $20,000\Omega/V$. If you use meter leads that are 2 feet long and have a resistance of 0.02Ω , what is the sensitivity of the meter movement?

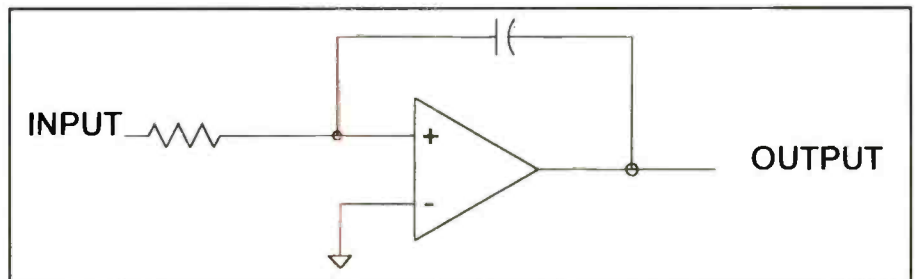
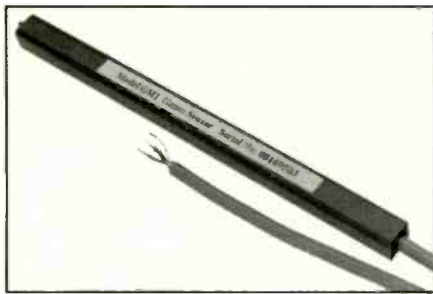

Figure 1. What is the function of this circuit?

6. If the waveform being digitized has a frequency that is more than twice the sampling frequency, a phenomena called _____ is very likely to occur.
7. The circuit in Figure 1 is
 - A. an integrator.
 - B. a differentiator.
8. If a pulse waveform is on for 20msec and off for 60msec the percent duty cycle of the waveform is _____.
9. When using an oscilloscope and generator to test for amplifier distortion, the advantage of using a sawtooth waveform instead of a square waveform is that the sawtooth waveform can show _____.
10. What is the symbol for the common-emitter current gain of a transistor?

(Answers on page 58)

Wilson is the electronics theory consultant for ES&T.



Magnetic fields sensor wand

Model GM1 is a linear Hall-Effect sensor from *B&B Electronics*. It can be used to measure magnetic fields up to ± 800 gauss at frequencies up to 20KHz. The six inch wand is 7/16 inch square and has a six foot shielded cable. The unit requires a 5V power supply and produces a linear output voltage proportional to the strength of the magnetic field.

A simple and inexpensive way to log the output of the GM1 to a computer is to use one of the company's SDA series of RS-232 Analog to Digital converters. A diskette including a data logging utility and serialized calibration data is provided with the GM1.

Circle (43) on Reply Card

Multi-function DMMs

Wavetek Corporation introduces two new hand-held digital multimeters (DMMs)—23XT and 28XT—to its XT Series line of testers. Both meters provide field service technicians with a combination of functions in a single unit.

The Model 23XT, combines electrical



measurements with electronic test functions for electrical systems installation and service testing. This meter includes ac/dc voltage and current, resistance measuring, logic and transistor testing, a thermometer that measures to 1400F and the Live ac quick check feature.

The 28XT is specifically designed for technicians and field engineers responsible for installing, maintaining or servicing HVAC/R systems. It combines a ther-

mometer, capacitance and frequency meter with a DMM, making this meter useful for these service professionals.

In addition to their individual capabilities both meters are equipped with a combination of features including max/data hold, easy-to-read oversized characters, auto-off, wide measuring ranges, fully-fused current inputs, safety test leads and input warning beepers.

Circle (44) on Reply Card

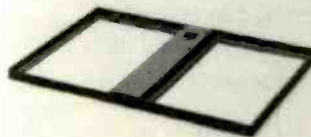

DS-5046 base frame

DS-5146 post kit for 46, 60, 76 cm antennas, used with DS-5046

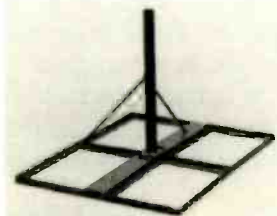

DS-5001 post kit for 1 meter antennas, used with 2 DS-5046 base frames

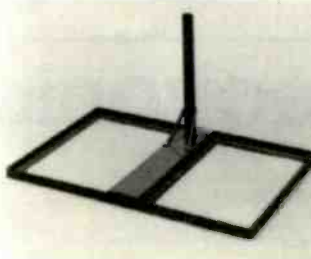

1 meter antenna with DS-5001 and 2 base frames

WINEGARD®
Clearly the World's Best®

Printed in U.S.A.
Winegard Company • 3000 Kirkwood St.
Burlington, IA 52601-2000

Non-penetrating roof mount

Winegard introduces new non-penetrating roof mounts for digital satellite antennas. These mounts are suitable for antenna sizes from 46 cm to 1 meter.

These non-penetrating roof mounts are suitable for most flat roofs. They are also a good alternative when a nonpermanent installation is desired, or if the antenna is moved to other sites.

Components for three different mount options are a base frame unit, and two types of post kits. A single base frame unit

covers approximately six square feet. Base frames are manufactured from steel and angle iron with a powder coat finish. Post units are steel with aluminum braces, and also have a powder coat finish.

For 46 and 60 cm antennas using a Winegard, Sony or RCA mounting foot, just the base frame, DS-5046, can be used. For antennas up to 76 cm, post kit DS-5001 is used with two base frames. All components will ship UPS.

Circle (45) on Reply Card

ES&T Book Shop

POWER
UP
YOUR
PRODUCTIVITY

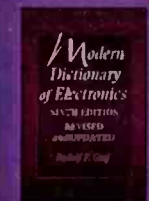
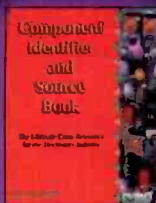

Component Identifier and Source Book
by Victor Meeldijk
This book was written to assist technicians to identify components from prefixes and logos, as well as find sources for various types of microcircuits and other components.
Order # 61088 \$24.95

Semiconductor Cross Reference Book, 4/E
by Howard W. Sams & Company
This newly revised and updated reference book is the most comprehensive guide to replacement data available. With more than 490,000 part numbers listed, technicians will have to problem locating the replacement or substitution information they need.
Order # 61080 \$24.95

ES&T Presents TV Troubleshooting & Repair
by ES&T Magazine
This book presents information that will make it possible for technicians and electronics hobbyists to service TVs faster, more efficiently, and more economically.
Order # 61086 \$18.95

ES&T Presents Computer Troubleshooting & Repair
by ES&T Magazine
Computer Troubleshooting & Repair features information on repairing Macintosh computers, monitors, hard drives and much more.
Order # 61087 \$18.95

The Howard W. Sams Troubleshooting & Repair Guide to TV
by Howard W. Sams & Company
This book is the most complete and up-to-date television repair book available. With timesaving features that even the pros don't know and extensive coverage of common TV symptoms.
Order # 61077 \$29.95

Internet Guide to the Electronics Industry
by John Adams
Whether it's programs that calculate Ohm's Law or a schematic of a satellite system, electronics hobbyists and technicians can find a wealth of knowledge and information on the Internet.
Order # 61092 \$16.95

Optoelectronics, Volume #1
by Vaughn D. Martin
This book is the first in a three-part series on optoelectronics. It is the introductory self-teaching text and includes descriptions of basic concepts, photometrics, and optics.
Order # 61091 \$29.95

IC Cross Reference Book, 2/E
by Howard W. Sams & Company
The engineering staff of Sams assembled the IC Cross Reference Book to help readers find replacements or substitutions for more than 35,000 ICs and modules.
Order # 61096 \$19.95

The Complete RF Technician's Handbook
by Götter W. Sayre
This book will furnish the working technician or student with a solid grounding in the latest methods and circuits employed in today's RF communications gear.
Order # 61085 \$24.95

PC Hardware Projects, Volume 1
by James Barbarello
Using commonly available components and standard construction techniques, this book will guide readers through the construction of a logic analyzer and a multiplex continuity tester.
Order # 61104 \$24.95

Modern Dictionary of Electronics, 6/E
by Rudolf F. Graf
This book is a classic, comprehensive reference book for engineers, technicians, students, and hobbyists.
Order # 67002 \$49.95

Understanding & Servicing CD Players
by Ken Clements
Written specifically with service technicians and engineers in mind, this book is designed as a bench-side companion and guide to the principles involved in repairing and adjusting CD players.
Order # 67057 \$49.95

YES! I want to learn from the experts. Rush me my book(s) right away!

Please add \$4 shipping & handling. **FREE shipping & handling for orders \$50 and over.**
Please make your check or money order payable to: Electronic Servicing & Technology

**To Order Call
516-681-2922**

Qty	Order#	Description	Price	Total Price
Shipping/Handling				
<i>New York Residents add applicable sales tax</i>			Total	

Name _____

Address _____

City _____ State _____ Zip _____

MC/VISA/AMEX/Discover # _____ Expires _____

Form of payment: MC VISA AMEX Discover Check Money Order

Please mail your orders to: **Electronic Servicing & Technology, 76 North Broadway, Hicksville, New York 11801-9962 FAX 516-681-2926**

the same month a year ago. On a year-to-date basis, sales in five of the industry's six video categories are running ahead of their 1996 pace.

"Manufacturers' depletion of excess inventories of projection and large screen televisions, as well as low prices of heavy promotion across all video categories, contributed to robust video product sales in February," said Jim Newbrough, Philips' Senior Vice President and General Manager, Mainstream Business. "This inventory adjustment, coupled with a continued strong economy, will help the introduction of new model lines during the second quarter.

In percentage terms, the most impressive results last month were posted by TV/VCR combinations, which jumped 54 percent to some 172,000 units. All screen sizes experienced significant gains

in February, helping growth of this product to 36 percent for the year-to-date.

February was an impressive month for camcorder sales as well, which reported 42 percent growth on unit sales of 188,000. For the first two months of 1997, more than 400,000 camcorders were sold to dealers, a 30 percent improvement over the comparable period last year.

VCR deck sales continued to grow last month, reaching 1.06 million units and making it the best February ever for videocassettes recorders. Not only did VCRs set a new February record, but they topped the previous record — posted in February 1996—by 25 percentage points.

Reflecting continuing interest in large-screen displays and home theater systems, sales of projection televisions grew nearly 25 percent last month to 55,000

units. For the January-February period, projection TV sales to dealers totaled 118,000 units, or 15 percent ahead of the first two months of 1996.

In the largest video category in terms of dollar volume, color TV receiver sales rose a respectable six percent in February to nearly 1.5 million units. Models with screen sizes of 25 inches and larger posted 18 percent growth with shipments of 784,000 units last month. For the first two months of 1997, color TV sales stand at some 2.7 million units, a 3.6 percent increase over January-February 1996.

Sales of laserdisc players continued to decline in February, slipping 26 percent to 6,662 units. Year-to-date, this category trails last year's two-month total by nearly 8,000 units, a 35 percent decline.

CEMA applauds broadcasters' DTV action

The Consumer Electronics Manufacturers Association (CEMA) announced today its endorsement of a proposal by the television broadcasters to expedite transmission of digital television (DTV) signal. By providing a digital signal, broadcasters will enable TV manufacturers to begin selling HDTV sets in late 1998.

"We are encouraged by the broadcasters' accelerated schedule for DTV rollout," said Gary Shapiro, president of CEMA. "We stand ready to work with the broadcasters and the FCC to make HDTV a reality, and this announcement brings us one step closer to that goal."

VICA conference to be held in Kansas City

The Vocational Industrial Clubs of America (VICA) will be holding its 33rd annual National Leadership and Skills Conference and Skills USA Championships at H. Roe Bartle Hall in Kansas City, MO, June 24-27, 1997. The Skills USA Championships is an annual event sponsored by National VICA, where 3,500 student gold medalists from their state compete in 57 occupational and leadership skills areas. For more information, contact Thomas W. Holdsworth, Director, Communications and Public Affairs, National VICA at 703-777-8810.

Test Your Electronics Knowledge

Answers to test

(from page 55)

- 1. sone
- 2. phon
- 3. The signals have to be pure sinewaves 90 degrees out of phase.
- 4. No—Pure sine waves do not have harmonic frequencies.
- 5. The sensitivity is the current needed for full-scale deflection. This parameter is the reciprocal of the ohms per volt rating. So, $1/20,000 = 50\mu\text{A}$.
- 6. aliasing—The question defines the condition for aliasing. It is a false digital representation of an analog waveform.
- 7. A—It is CALLED an integrator, but it is not a very good one. A series of evenly spaced short-time pulses should produce a step voltage output. However, the steps are crowded at the top with the circuit shown.
- 8. 25% - Percent duty cycle is (on time) divided by (total time) multiplied by 100. So, $(20/80) \times 100 = 25\%$.
- 9. clipping.
- 10. (beta)

Newnes Data Communications Pocket Book, Third Edition, by Mike Tooley, Newnes, 256 pages, hardcover \$24.95

Written by the Dean of Technology at Brooksland College in Surrey, England, this new edition of the pocket book is for technicians and engineers involved with the installation and maintenance of data communications equipment.

This latest edition of the *Newnes Data Communications Pocket Book* has been substantially updated to keep abreast with the rapid pace of developments in data communications technology. New topics have been introduced, including such subjects as data compression, the Internet and World-Wide Web, HyperText Markup Language—and existing material has been updated and expanded.

Newnes, 313 Washington Street, Newton, MA 02158-1626

Embedded Microprocessor Systems: Real World Design, by Stuart Ball, Newnes, 184 pages, paperback \$29.95

Embedded Microprocessor Systems: Real World Design covers many microprocessor families while enumerating practical tips and pitfalls to avoid. This book is an introduction to the design of embedded microprocessor systems from concepts through debugging.

Unlike many microprocessor books, this book is not limited to any specific processor family, but describes interfaces and operations of several families, with emphasis on cost and design trade-offs. Two complete embedded systems are used throughout to illustrate specific concepts.

The text includes numerous examples, tips, and pitfalls, which can help prevent time-consuming and expensive mistakes. Particularly important is the chapter on interrupts, with detailed descriptions of possible problems related to interrupts and warnings on what to avoid.

The book's contents include the following: System Design; Hardware Design; Software Design; Interrupts in Embedded Systems; Adding Debug Hardware and Software; System Integration and Debug; Multiprocessor Systems; Real Time Operating Systems; and Industry-Standard Embedded Platforms.

Stuart Ball is a Senior Electrical Engineer at Oregon Teknika, an Oklahoma

City manufacturer of medical electronic equipment, and has worked for the past 15 years in the field of embedded control systems. He has written articles for such periodicals as *Circular Cellar INK*, *Byte*, and *Modern Electronics*.

Newnes, 313 Washington Street, Newton, MA 02158-1626

World Class Customer Service, by Bob Ing, Ph.D, The Electronics Technicians Association, 50 pages, paperback \$19.95

ETA has now published a new book titled *World Class Customer Service*. The book is intended for electronics technicians and support personnel to help them understand the importance of personal relations with customers, fellow workers, and others they make contact with during their work day.

Written by Bob Ing, Ph.D, of Toronto, Ontario, Canada, and edited by the staff of the Electronics Technicians Assn., Greencastle, IN, the new book creates an understanding of the relationships between sales, marketing and customer service functions of a business. It includes ETA's Code of Conduct as well as locations of over 350 examination proctors.

Telephone techniques; technical literacy; safety; record keeping; productivity; personal behavior; up-close customer service techniques; proper language and other people skills, as well as an overview of very basic electronics lingo are covered in the book. Each chapter contains a quiz, and a 50 question practice exam is available as the final chapter.

ETA recommends the book as a study

guide for the Certified Customer Service Specialist (CSS) examinations the association has offered since 1991.

For more information call ETA at 317-653-4301 or Fax to 317-653-8262.

ETA, 602 N. Jackson, Greencastle, IN 46135

Linear IC Applications: A Designer's Handbook, by Joe Carr, Newnes, 356 pages, paperback \$47.95

Linear IC Applications: A Designer's Handbook is about practical applications of linear IC circuits. Although most of the circuits are based on the ubiquitous operational amplifier, other devices are examined as well. The material in this book will allow you to design circuits for the applications covered. But more than that, the principles of design for each class of circuit are transferable to other projects that are similar in function, if not in detail.

Newnes, 313 Washington Street, Newton, MA 02158-1626

Battery Reference Book, Second Edition, By T.R. Crompton, Butterworth Heinemann, 752 pages, paperback \$94.95

Totaling more than 60 chapters, this book covers electrochemical theory as it applies to batteries; battery selection; theory, design, electrical and performance characteristics; applications of various types of battery; theory and practice of battery charging. The book provides comprehensive information from manufacturers about the performance characteristics of the batteries they supply.

The book is a comprehensive reference source now available in paperback.

Butterworth Heinemann, 313 Washington Street, Newton, MA 02158



Store Management Software

Designed Exclusively For
Electronics & Appliance Sales & Service Stores

STORE-TRAK, Release 3.22

An easy-to-use menu-driven system that organizes every aspect of your business more effectively, using state of the art programming technology.

Turnkey Hardware/Software Systems Available!

Financing Options!
Eliminates Paperwork & Filing ✦ Detailed Business Summaries ✦ Fully Networkable

1-800-603-9000 Ext. 99
123 N.W. 13th Street, Suite 213 Boca Raton, Florida 33432
<http://www.sbsdire.com>

Circle (79) on Reply Card

CLASSIFIED

Classified advertising is available by the word or per column inch.

By-the word. \$1.65 per word, per insertion, pre-paid Minimum charge is \$35 per insertion. Initials and abbreviations count as full words. Indicate free category heading (For Sale, Business Opportunities, Miscellaneous, Wanted). Blind ads (replies sent to ES&T for forwarding) are \$40 additional. No agency discounts are allowed for classified advertising by the word. Contact Kirstie Wickham at 516-681-2922 to place your classified ad (by-the-word). Mastercard, VISA, American Express and Discover are accepted for FAX or mail orders.

Per column inch (classified Display): \$235 per column inch, per insertion, with frequency discounts available, 1" minimum, billed at 1/4" increments after that 10" maximum per ad. Blind ads are \$40 addition. Reader Service Number \$25 additional to cover processing and handling costs. (Free to 4-inch or larger ads.) For more information regarding classified display advertising please call 516-681-2922. Optional color (determined by magazine) \$150 additional per insertion.

Send your order, materials and payments to:

Electronic Servicing & Technology, 76 N. Broadway, Hicksville, N.Y. 11801 Attn: Classified Department Ph: 516-681-2922 FAX: 516-681-2926

FOR SALE

FURTHER PRICE REDUCTION. Diehl Mark III \$49, Diehl Mark V Horizontal circuit tester \$169. New. Conductive coating for remote control keypads \$9.99 ppd. **WEEC**, 2411 Nob Hill Road, Madison, WI 53713. 608-238-4629, 608-273-8585.

SENCORE, TEKTRONICS, HEWLETT PACKARD (all models). We **BUY, SELL, & TRADE**. Please call "**CHOICE ELECTRONICS**" for all of your test equipment needs. Complete financing options available. Call 1-800-609-0677, ask for Lance Tople.

NAP Tuner 340309 RCA Tuner TCHRIA or TCCRIA. Snowy picture? Will repair for \$25.00, Free Shipping. **Tip Top TV & VCR**, 18441 Sherman Way, Reseda, CA 91335, 818-345-1974.

CRT ADAPTER KIT - Hooks your CRT tester to ALL picture tubes. Win the "socket war". Obsolete proof! \$59.00. **DANDY** 2323 Gibson, Muskogee, OK 74403. 918-682-4286.

• • • **21,391 SERVICE TIPS** • • • **SPECIAL OFFER** • • •
Our latest **Volume Update** is **FREE** when you order the **SERVICE TIPS program!** **STAY AHEAD OF YOUR COMPETITION!** Technicians worldwide know **SERVICE TIPS** IS THE MOST VALUABLE PIECE OF EQUIPMENT YOU CAN OWN TODAY. **Start cutting your troubleshooting time down and increase YOUR PROFITS.** **SERVICE TIPS**, with over 117 CURRENT Manufacturer/Brands is the **ONLY PROGRAM** with actual technician findings and is **SUPPORTED BY ITS CREATORS & APPROVED** by National Electronics Service Dealers Association. **NO SERVICE CENTER SHOULD BE WITHOUT IT!** **DON'T WAIT!** Order **SERVICE TIPS & VOLUME #19 NOW** for just **\$169.95 + s&h.** **ELECTRONIC SOFTWARE DEVELOPERS INC.** 826 So Main St., So. Farmingdale NY 11735 or **e-mail** us at **esd@pb.net** or visit our **Web site** at: **www.pb.net/vcrtips**
•••••••••••••••• **CALL TODAY 1-800-621-8477** ••••••••••••••••

TEST EQUIPMENT BOUGHT & SOLD: OSCILLOSCOPES, ETC. 510-706-0177. FAX: 510-706-0156.

Large collection of antique 1940's televisions & radios. Must sell, moving. \$600.00 or best offer takes all. **Call John, 703-536-4442.**

TV CASE HISTORIES: Booklet with 2,825+ histories. Satisfaction assured. Only \$56 (plus \$3.00 for priority mail). **Mike's Repair Service**, P.O. Box 217, Aberdeen Proving Ground, MD 21005. Same mailing address 33 years. Send SASE for samples. 410-272-4984, 1-800-2-FIX TVS 11am-9pm. (or at <http://www.netgsi.com/~mikesrs>).

SERVICE DATA & HARD TO FIND PARTS previously-owned SAMs, manufacturers data, books, **FREE** catalog. **AG Tannenbaum**, Box 386, Ambler, PA 19002, 215-540-8055, fax 215-540-8327.

Sencore Electronic Testing Equipment: TVA92, SC3100, PR57, TF46, SM2001. In use approximately 18 months. Price \$9,500.00. Call Mon-Fri 9 to 5 919-496-2764, Sat., Sun 919-496-3037, Fax 919-496-2764.

FOR SALE

Computer monitor service information. Windows Tech-Tips service program. Over 700 monitor schematics, ESR in-circuit capacitor tester. Visa, MC, Amex. **MI Technologies Inc.**, 513-335-4560, Fax 513-339-6344. E-mail: mit335@bright.net, Web: <http://www.bright.net/~mit335>.

((**32,000 REPAIR TECH-TIPS**)) **TEST** our **FULL DATABASE** of repairs in **CD-FORMAT, DOS or WINDOWS** for **ONE WEEK** in **YOUR SERVICE CENTER** for \$20.00. If satisfied, you may join our membership for an additional \$330.00. Over **2,300 members World-Wide** and growing. Our membership price has been the same for the past six years and will remain the same in the future. **"FREE"** 48 Page Member Magazine **"THE TIP INFORMER"**, **"FREE"** Emergency Tech-Assist Telephone Line, **"FREE"** FCC-ID Cross-Reference Manual, **"FREE"** Service Center Forms. **Semi-annual updates of 2,000 new repairs.** Paper Manuals or Computer, **CD, DOS or True Windows** in which you may enter your own repairs, edit or tag any report or press one key and printout selected or all repairs on a particular Model or Chassis. **"GET TO THE BOTTOM LINE PROFITABLY"** CALL and speak to a Service Center Owner and Technician ED Erickson, **NESDA MEMBER** and past president of the (**PROFESSIONAL ELECTRONICS ASSN. OF SOUTH FLORIDA**). You and your technicians will be glad you did! Remember, labor is your largest expense. **800-474-3588 or 954-349-2455, TV-Man Tech-Tips, Inc.** 2082 Augusta, Weston, Florida 33326.

18,000* Valuable BOARD LEVEL TECHNICAL REPAIRS *FREE DEMO REPAIRS** for TVs, VCRs, Projection TVs, Camcorders, CD Players, Audio & other electronics organized in an **EASY** to use Computer Program - **The TECHNICAL TIP REPAIR Program.** **PROFESSIONAL BOARD LEVEL & COMPONENT LEVEL REPAIRS.** **ADD** your own tips. **PRINT** tips. **BACKUP** & save your own tips. Have your own tips? Ask about our **TIP EXCHANGE** policy with *FREE Updates****. Works on IBM compatible computers with a hard drive (Also on some Apple Macintosh). **ONLY \$150.00 **FREE SHIPPING**.** **NEW VERSION** works in **DOS, WINDOWS 3.1 & WINDOWS 95.** *****FREE DEMO***.** **HIGHER INTELLIGENCE SOFTWARE, 60 FARMINGTON LANE, MELVILLE, NY 11747.**
*******CALL 1-800-215-5081/1-516-643-7740*******

Service tips. Over 10,000 Quality tips. KD T-V and 30 NESDA and other Professional Servicers. 200 brands, TV-VCR-CM-MWO-CC-Audio-Misc. Diskette database \$39.95. New version monthly. Finest Original Data! Power record adding feature! Alphabetized symptoms! Upgrade \$29. Annual subscription (12 disks) \$12.50/mo. **KDTV 514 3rd St. Aurora, IN 47001. 812-926-4321.** All c/cards. Send your own tips for **FREE UPGRADE.**

Closing Shop, SC61 oscilloscope, \$1,500.00 or best offer. Also, older test equipment, old radios and tubes. Call for list. **860-526-9101, 860-526-9619.**

IN-CIRCUIT CAPACITOR ESR TESTER - Find bad caps **FAST** and **RELIABLY** with the new Capacitor Wizard in-circuit ESR Tester! Great for monitors, switching power supplies, TVs, etc. Only \$179.95. MC/VISA. **Independence Electronics Inc., 800-833-1094, www.awiz.com.**

CLASSIFIED

FOR SALE

Service Literature bought and sold. Previously owned VCR, Sams, Ham, test equipment manuals. Call, fax, or write with your wants. **IDC Electronics**, 3471 West Broadway Ave., N. #252, Robbinsdale, MN 55422. Phone/fax **612-588-6898**. E-mail: fallen-idceworldnet.att.net.

For Sale - Brand New Sencore VC93 VCR Analyzer, SC3100 100MHz oscilloscope, PM82 Power mp Analyzer, PA81 Power Max, LC102 Capacitor-Inductor Analyzer, TF46 Super Cricket, SCR250 SCR Triac, Lots of Repair Parts - Cost \$13,000. Will sacrifice All \$5,500. 319-388-2547, Jay.

Out of Business: Must Sell Everything. Low prices. Sams 1-1096 and up-to-date tubes. Test equipment, mint condition. Old and New Parts. Call, **718-639-8719** anytime.

BUSINESS OPPORTUNITIES

TV/VCR DSS Shop. Pinellas County, FL. Fully stocked with truck. \$8,500.00. 813-942-3085.

HELP WANTED

LOOKING FOR AN EXPERIENCED CAMCORDER & VCR TECH. - 8MM AND VH-C IN NEW YORK CITY. CALL 212-473-0215 ASK FOR GLENN.

**To ADVERTISE IN THE CLASSIFIEDS
CALL 1-516-681-2922 OR FAX 516-681-2926**

READERS' EXCHANGE

Readers' Exchange is a free service.

The following restrictions apply to Readers' Exchange:

- Only individual readers may use Readers' Exchange, and items must be restricted to those that are ordinarily associated with consumer electronics as a business or hobby. If you're in business to sell the item(s) you want to offer for sale, the appropriate place for your message is in a paid advertisement, not Readers' Exchange.
- Readers' Exchange items must be restricted to no more than three items each for wanted and for sale.
- All submissions must be typed or printed clearly!

Send your Readers' Exchange submissions to:

Readers' Exchange, Electronic Servicing & Technology, 76 North Broadway, Hicksville, New York 11801

FOR SALE

Three by five foot Emerson lighted, double-sided sign. In original carton (never used). Also a pipe stand. Original cost, \$150.00. Best offer. Contact: *White's TV Service, 622 N. 5th Street, Hollis, OK 73550, 405-688-2612.*

Sencore MU150 and TC162 tube tester. B&K 820 with charger. And much more. All come with probes and manuals. Best offer. Contact: *Fred Ingersoll, GI Electronic, 6845 Lathers, Garden City, MI 48135.*

Sencore CVA94 and Sencore VR940, used twice, \$2000.00. Sencore VC93 never used, \$1500.00. With cables and manuals. Will pay shipping. Contact: *Gordon Wilmot, 12 Putnam Road, Hyde Park, NY 12538 or call 914-229-0478 between 9AM -5PM EST M-Th.*

Sencore TVA92, VG91 1995 models with cables, manual and schematics. Excellent condition, little use. Contact: *208-678-1782.*

Sencore TVA92, TV Analyzer, \$1700.00. Excellent condition with all probes, manuals, and shipping container. Contact: *Steve, 814-455-8741 or e-mail: yogeshvara@aol.com.*

Sencore VC93, new. All cables, VHS tape, original box, \$2000.00. Contact: *250-338-9623, leave message.*

Sencore CR168 picture tube tester, 22 adapters. Please send SASE for list. \$50.00 plus shipping. Contact: *Boulevard TV & VCR Service, 1431 Robinson Avenue, Havertown, PA 19083. 610-446-4519.*

Hickok signal generator 615. Photofact 1-1709. New tubes. Contact: *Ann Bichanich, 1511/2 W. Lake Street, Chisholm, MN 55719, 218-254-4421.*

B&K E2000 signal generator. B&K model 501A semiconductor curve tracer. Precision multimeter, and other equipment. Contact: *Ken's Engineering, 31 Hyman Drive, D.D.O. Quebec, Canada H9B 1L5, 514-421-0517 (call after 6 PM).*

WANTED

Colortyme Television H12-1-2-3-3R chassis schematic. The chassis was made by NEC. Will pay for copy of schematic. Contact: *215-548-3383, can call collect.*

Operators manual for Compuadd model 325 computer, circa 1992, full size desk model. Contact: *Robert Miller, Rt 1, Box 223, Anadarko, OK 73005.*

Need instructional manual for Heathkit VTM model IM-38. Will copy and return or will buy. Contact: *Joseph V. Schember, 1017 West 24 Street, Erie, PA 16502.*

2-NEC D7811G micro-computer chips. Contact: *John Detroyer, 13405 Burt Road, Riley, MI 48041, 810-395-7819.*

Service manuals for Zenith PV 800 projector. Contact: *T&D Electronics Service, 410-398-0471.*

Nap ATU019-A001 tuner control module for Phillips model 27H326-SB02 - Using 27C9-15 chassis. New or good used. Contact: *Price TV, 145 E. Howard Street, Parker City, IN 47368, 765-468-6858.*

Television collector looking for any pre-1940 TV, pre-1948 RCA TV and unusual pre-1960 TVs. Contact: *Bill Russell, 3236 Laurel Canyon Road, Santa Barbara, CA 93105, 805-682-8115 (phone), 805-682-0865 (fax), e-mail: oldtvs@aol.com.*

JVC VCR model HR-D540U Zerox copy of power supply schematic. Contact: *John Augustine, 3129 Eassl Street, Lauderdale, PA 19605, 610-929-8850.*

Early radio wireless books, magazines, ads for possible research article on radio. Will pay nominal fee if needed. Contact: *Donald S. Maurer, 29 South 4th Street, Lebanon, PA 17042, 717-272-2481.*

Heathkit AC VTVM model IM-38 instructional manual. Will purchase or copy and return promptly. Contact: *Joseph V. Schember, 1017 West 24 Street, Erie, PA 16502-2424.*

Tech's Guide To Pricing **NEW**

Sperry Tech's Pricing Guide
 Updated new 6th edition... a framework for setting rates that apply to Hi-Tech products... a formula that guarantees SUCCESS!
 Call Toll Free for details 1-800-228-4338

Circle (76) on Reply Card

TUBES • TUBES • TUBES
World's Largest Range
 Over 2,000 Types, Domestic & Foreign

UP TO 85% OFF Ask for price list

International Components Corporation
 Toll Free 800-645-9154 • N.Y. State 516-293-1500
 107 Maxess Road, Melville, New York 11747

Circle (65) on Reply Card

The Ultimate WWW Service Site
www.electronix.com
The One-Stop Service Site for Electronic Technicians

Electronix Corp 313 W Main St Fairborn, OH 45324
 (513) 878-1828 Fax (513)878-1972 sales@electronix.com

Circle (62) on Reply Card

HERMAN ELECTRONICS

Visit our new Home Page at
<http://gateintl.com/hermanelec>

LEADER
 FOR PROFESSIONALS WHO KNOW THE DIFFERENCE

See our ad on page 7
 Call 1-800-645-5104
 for full line catalog

National Computer Association, Inc.

The National Computer Association brings together computer professionals to promote matters of importance to you. We want to make the computer industry a better place for our members to work, while increasing the confidence of the public that buys from them.

Please See Our Ad on Page 17
 or Visit Our Website at www.nca-net.com

1-800-615-6224

ADVERTISERS' INDEX

Company	Page Number	Reader Service Number	Advertiser Hotline
AnaTek Corporation.....	22	60	800/999-0304
B & K Precision	19	111	773/889-1448
Dalbani Corporation.....	11	61	800/325-2264
EIA/CEMA	25	112	703/907-7656
Electronic Servicing & Technology Books	57		800/853-9797
Electronics Technicians Association	23	71	317/653-4301
Electronix Corporation.....	64	62	513/878-1828
Exttech Instruments.....	11	63	617/890-7440
Herman Electronics.....	64		800/938-4376
ITT Pomona.....	21	64	909/623-3463
ISCET.....	49		817/921-9101
International Components Corp.	64	65	800/645-9154
Instek.....	22	66	818/336-6537
Jesse Jones Industries.....	20		800/825-6690
LG Precision.....	26	67	562/404-0101
Leader Instruments.....	7,64	101,102	800/645-5104
MCM Electronics	15	68	800/543-4330
NCA/National Computer Assn.	17,64	69	800/615-6224
Parts Express	49	70	800/338-0531
Philips Software Development.....	IFC	117	423/475-0393
Philips Service Company	IBC	120	800/851-8885
Quantum Data	23	7	847/888-0450
SBS Direct.....	61	79	800/603-9000
Sams & Company, Howard	14	72	800/428-7267
Sencore	41,43,	73,74	
	45,BC	75,1	800/SENCORE
Sperry Tech	64	76	800/228-4338
Tentel.....	12	77	800/538-6894
Thomson Consumer Electronics.....	2,3	113	800/336-1900
Wavetek.....	9	97	800/854-2708

We'd like to see your company listed here too. Call Diane Klusner at 516/681-2922 or E-Mail her at dianekest@aol.com to work out an advertising program tailored to suit your needs.



SALES OFFICE
PHONE (516) 681-2922
FAX (516) 681-2926

**Smart
Accessories**
The Intelligent Choice

Dumb Accessory

Smart Accessories



Do the Smart Thing. Sell Philips Accessories and Make More Money Now.

When you sell Philips Smart Accessories you're really using your head. That's because Smart Accessories give your customers all the extras they want—while adding a little extra to your bottom line.

So, get on top of the game and call the Philips Sales Center to order Philips Smart Accessories—your one-stop shop for parts, accessories and service aids. Anything else just isn't very smart.

To place your order call **1-800-851-8885** today.

401 E. Old Andrew Johnson Highway, P.O. Box 555, Jefferson City, TN 37760 • Fax 1-800-535-3715

Let's make things better.

Circle (120) on Reply Card



PHILIPS

Streamline Your Service Center!

Service Assistant¹⁶
by Sencore

The First Fully Integrated, Windows™ Based Business Management Software System That's Guaranteed To Streamline Your Repair Processing By 50% Or More For Increased Profits And Productivity!

Service Assistant is the only fully integrated business management tool for today's electronic service center. From customer drop off to customer pick-up, Service Assistant gives you a complete tracking system that allows you to quickly monitor the status of any job, as well as assist you in managing your entire service operation, including;

- Windows™ Based Operation
- Technician Productivity
- Accounts Payable
- Purchasing & Check Printing
- Full Data Import/Export
- Service Call Scheduling
- Time Spent On Repairs
- Accounts Receivable
- Complete Inventory Processing
- And Much, Much More

NEW!

To learn more about the New Service Assistant business management software, give us a call at **1-800-SENCORE**. Be sure to ask about our CD-ROM demonstration disk

CD ROM Demonstration Disk Now Available!



SENCORE
3200 Sencore Drive, Sioux Falls, SD 57107
Direct: (605)339-0100 Fax: (605)339-0317

Circle (1) on Reply Card