

BUILD PROJECTS AND DISCOVER ELECTRONICS

ELECTRONIC PROJECTS

101 ELECTRONIC PROJECTS

CC 02272

For Under \$15-All Easy To Build

1977 EDITION \$1.35

Low Cost Projects You Can Build Tonight!

- CB Pager
- SWL's Signal Booster
- Audio Powermeter
- Appliance Tester
- Power Failure Alarm
- Plus 96 more!!!!

30 IC Projects

- CB Channel Booster
- Photo Timer
- Signal Tracer
- Lie Detector
- And more!!

Bonus

Special Projects

- Mod-X Digital Clock
- 555 Tester
- Darkroom Color Analyzer
- And more!!!

Hobby Electronics Newsletter

(See page 85)

CERTIFIED GOOF-PROOF PROJECTS

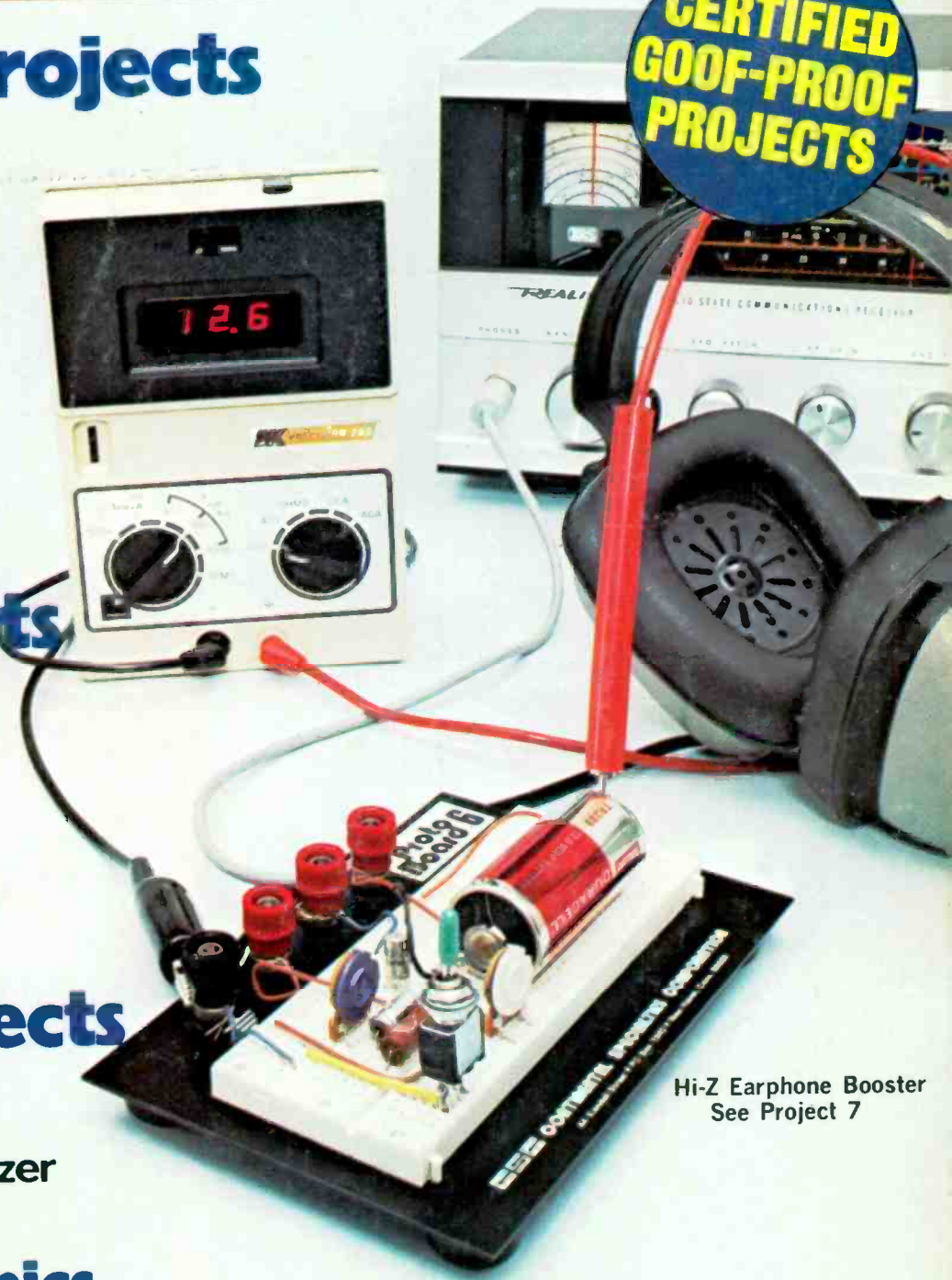

Hi-Z Earphone Booster
See Project 7

Build the REAL THING—Yourself!

Get top mileage from your own craft skills



367. ROBIN is a versatile skiff that can be used for hunting or fishing, as a yacht club tender, or a work boat. It is rugged, yet its plywood construction makes it easy to build; no special jig or tools are needed. It can take a motor of 7-10 hp. L.O.A., 12'; beam, 5'1". **\$5.00**



75. KINGFISHER is a modern version of the Scandinavian pram developed hundreds of years ago. It rows easily, sails well, and propels nicely with a small outboard motor. Its 90 lb. weight and small size make it ideal to car-top; construction is plywood. L.O.A., 9'; beam, 4'. **\$5.00**



245. CAT'S PAW catamaran provides a stable base for a lot of sail area to make for fast sailing. And she's easy to build because of her straight-sided hulls, flat sheer, and straight bow and stern. It's an ideal boat in which to learn sailing. L.O.A., 12'; beam, 6'2"; sail area, 85 sq. ft. **\$6.00**

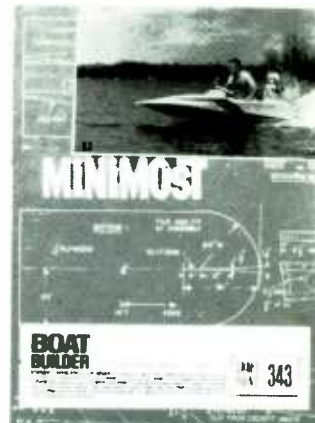

343. MINIMOS is an 8' outboard sports hydro you can build in just 15 hours, and at a cost of less than \$25 for materials. Its advanced underhull design makes speeds in the 30 mph range possible with a 10 hp motor. L.O.A., 8'. **\$5.00**
Full-size pattern set 344 **\$15.00**

Make it with Craft Prints and save hundreds of \$\$!

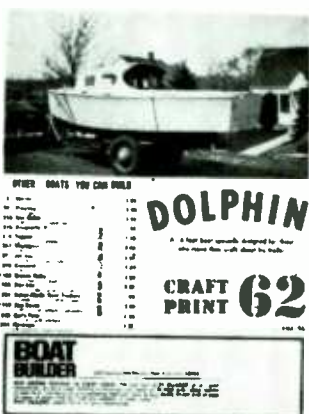

62. DOLPHIN is small and light enough to be transported anywhere by trailer, yet it will accommodate two persons for extended cruising or a party of four on day trips. Plywood is used throughout, and the hull is designed to get the most from modest power. L.O.A., 16'; beam, 5'9". **\$5.00**



356. TABU gets up on plane, just like an outboard, to provide speeds up to four times higher than those possible with a conventional hull of the same size. Hull is of plywood, covered with resin and Dynel cloth. L.O.A., 18'; beam, 4'8"; draft, centerboard down, 2'6"; sail area, 165 sq. ft. **\$5.00**

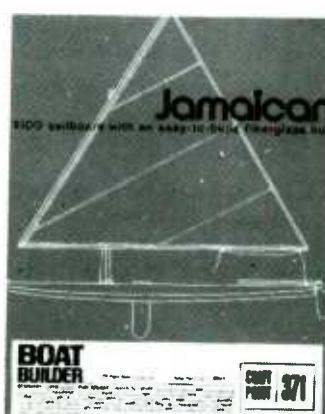

371. JAMAICAN is a sailing surfboard of unique construction. Fiberglass and Dynel cloth are stretched and stapled in place over a wooden framework, then resin is applied. No special building jigs or forms are needed. Foamed-in-place polyurethane adds stiffness. L.O.A., 12'; beam, 3'. **\$5.00**



36. CHUM is a speedy little runabout that can be built as a single cockpit or double cockpit model. Use a light-weight engine of no more than 100 hp for top performance. Construction is of marine plywood over hardwood frames. Decks are of mahogany-faced plywood. L.O.A., 15'6" **\$5.00**

COMPLETE AND MAIL TODAY

See extra coupon on page 15.

Boat Builder 229 Park Avenue S. New York, N.Y. 10003

101EP7

Enclosed is _____. Please add 50¢ for postage and handling. Send me the Craft Print(s) I have checked below:

- #367 \$5.00 Add 50¢
- #245 \$6.00 Add 50¢
- #62 \$5.00 Add 50¢
- #371 \$5.00 Add 50¢

- #75 \$5.00 Add 50¢
- #356 \$5.00 Add 50¢
- #36 \$5.00 Add 50¢

- #343 \$5.00 Add 50¢
- #344 \$15 full-size pattern set. Add 50¢

SATISFACTION GUARANTEED.

Name _____

Address _____

City _____ State _____ Zip _____



You can turn the CB boom into income... with NRI's Complete Communications Course

NRI can train you at home for a part-time job or a full-time career in communications.

The field of communications is bursting out all over. More than 25 million CB sets are in operation with millions more being sold annually. That means countless careers in design, installation, and maintenance. Start training at home now, the NRI way.

Get your all-important FCC License.

FCC rules require that CB transmitters be serviced only by the holder of a First or Second Class FCC Radiotelephone License, or under the supervision of a license holder when the transmitter is connected to a "radiating antenna." NRI will give you the necessary training to get that all-important First or Second Class FCC Radiotelephone License so that you can qualify for one of the many available openings.

Learn on your own 400-channel digitally-synthesized VHF Transceiver.

The 48-lesson NRI Complete Communications Course teaches you to service and adjust all types of two-way radio equipment (including CB), using the one unit that is best equipped to train you for CB, Commercial, and Amateur Communi-

cations...a "designed-for-learning," 400-channel, two-meter VHF Transceiver and AC power supply. Then we help you get your FCC Amateur License, with special instructions so you can go on the air. The unit can be mounted in your car, or you can use it as a base station.

The complete program includes 48 lessons, 9 special reference texts, and 10 training kits. Also included are: your own electronics Discovery Lab™, a new Antenna Applications Lab, an Optical Transmission System, CMOS Digital Frequency Counter, and TVOM. The course covers AM and FM Transmission Systems; Radar Principles; Marine, Aircraft, and Digital Electronics; and Mobile Communications. You must earn your First Class Radiotelephone FCC License or you get your money back.

TM McGraw Hill CEC



CB Specialist's Course also available.

NRI now offers a special 37-lesson course in CB Servicing. You get your own 40-Channel CB Transceiver, AC power supply and multimeter, for hands-on training. Also included are 8 reference texts and 14 coaching units to make it easy to get your Commercial Radio-tele-

phone FCC License—enabling you to test, install and service communications equipment.

Over a million have enrolled with NRI.

Send for the free NRI catalog and discover why more than a million people like yourself have chosen the NRI way as the right way to get ahead. You learn at home with bite-size lessons, progressing at your own speed to your FCC License and then into the communications field of your choice. There's no obligation and no salesman will call.



If Insert card has been removed, write:

NRI
McGraw Hill
Education Center
 3939 Wisconsin Avenue
 Washington, D.C. 20016
 79-047

101 ELECTRONIC PROJECTS FOR UNDER \$15

1 SWL's Super Signal Booster	20	35 Record Restorer	33	69 Easy Auto Theft Alarm	46
2 Wireless BC Booster	20	36 FM Overload Filter	34	70 Better Scope Calibrator	47
3 Communications Rebroadcast	21	37 Hook-up Remote Speakers	34	71 Appliance Tester	47
4 No Parts BC Booster	21	38 Audio Z-Matcher	34	72 Light Activated Power Control	47
5 Earphone Limiter for CW	21	39 Budget Mike Mixer	35	73 Speaker-a-Mike Preamp	48
6 SWL's Simple Squelch	22	40 Stereo Balance Meter	35	74 Basic Color Organ	48
7 Hi Z Earphone Booster	22	41 Magnetizer-Demagnetizer	35	75 Lo-Parts Treasure Locator	48
8 Crystal-Transistor Radio	22	42 Add-a-Tweeter	36	76 Photo Print Meter	49
9 Self-Powered CW Monitor	23	43 Mike Input Generator	36	77 Action Freeze Photo Trip	49
10 29¢ Mag. Phone Filter	23	44 Automatic Hi-Fi Shutoff	36	78 Remote Flash Trigger	54
11 Pep Up a Pocket BCB	23	45 Tape Dubbing Filter	37	79 Flash Tester	54
12 CB/AM Coupler	24	46 Tape Dubber's Pad	37	80 Variable Flood Lighting	54
13 Scope Your CB Signal	24	47 100 kHz Marker Oscillator	37	81 Angler's Bite Booster	55
14 CB Pager	25	48 Crystal Activity Checker	38	82 Commercial Killer	55
15 CB Modulation Lamp	25	49 455 kHz Alignment Osc.	38	83 Make a Voltage Doubler	55
16 Talk Power Booster	25	50 Fancy Flasher Lamp	39	84 12 to 9 for Transistors	56
17 CB Modulation Monitor	26	51 Logic Probe	39	85 A Regulated Nine	56
18 CB RF Detector for VOM/VTVM	26	52 Audible Logic Probe	40	86 Dry-Cell Charger	56
19 CB Remote Volume Control	27	53 Sine Wave Squarer	40	87 Lo-Hum Power Supply	57
20 Low Voltage Diode Tester	27	54 Active Square Shaper	40	88 Zener Regulator	57
21 Fire Up a Nixie	27	55 Super Sniffer	41	89 AC Adaptor	57
22 Versatile Tone Oscillator	28	56 Simple AM Mod. Monitor	41	90 AC Line Regulator	58
23 Audio Powermeter	28	57 Miladaptor for VTVM	42	91 Basic Power Supply	58
24 Audio Distortion Meter	29	58 Super Sensitive FSM	42	92 Tone Controlled Relay	58
25 Hi-to-Lo Z Mike Amp	29	59 Two-Dollar Signal Source	42	93 Power Tool Torque Control	59
26 Low Power Safety Light	29	60 Easy Field Strength Meter	43	94 Vari-Rev Motor Control	59
27 Headlight Minder	30	61 Budget Scope Calibrator	43	95 Fancy Guitar Fuzz Box	60
28 Slide Show Stopper	30	62 Time Base Reference	44	96 Wide Range Funk Box	60
29 Fail-Safe Emergency Light	31	63 Doorknob Security Alarm	44	97 NiCad Battery Charger	61
30 Lo-Cost Lamp Dimmer	31	64 Foil-a-Burglar Alarm	45	98 AC Motor Power Brake	61
31 Bull Horn	31	65 Open Circuit Burglar Alarm	45	99 Simple Signaller	61
32 Easy to Build Speech Clipper	32	66 Auto Ignition Maze	45	100 Yelp Oscillator	62
33 Simple RFI Filter	32	67 Latching Burglar Alarm	46	101 Twang-a-Matic	62
34 Stereo Beat Filter	33	68 Power Failure Alarm	46		

ADDED BONUS—30 INTEGRATED CIRCUIT PROJECTS

IC1 SWL's Super Calibrator	64	IC11 Mighty Mite Signal Tracer	69	IC21 Cigar-Size Amplifier	73
IC2 Lie Detector	64	IC12 100X Instrument Amp	69	IC22 Protect-a-Volt	73
IC3 CB Mobile-to-Base Power Unit	65	IC13 C Booster	70	IC23 Hi-Level 4-Channel Mixer	74
IC4 CB Channel Booster	65	IC14 Notch Filter Oscillator	70	IC24 SCA Adaptor	74
IC5 5V/3A for Digital Projects	66	IC15 Electric Butler Intercom	70	IC25 Stereo Mike Preamp	75
IC6 Bi-Polar Power Supply	66	IC16 Ultimate Talk Power	71	IC26 Comm-Press Log Amp	75
IC7 Bi-Polar Power Amp	67	IC17 Tape Head Preamp	71	IC27 Porta-Groove Amp	76
IC8 Groove Booster	67	IC18 Stereo Balancer	72	IC28 Record Remote Amplifier	76
IC9 Photo Timer	68	IC19 The Basic Amplifier	72	IC29 Far Out Gain Control	77
IC10 Bargain Tape Preamp	68	IC20 Versatile Hi-Pass Filter	73	IC30 No-Noise Mike Preamp	77

ADDITIONAL PROJECTS AND DEPARTMENTS

Ask Hank, He knows!	6	Literature Library	63	Select-A-Speed Motor Control	87
New Products	9	Mod-X, Simplest Clock Yet	78	Darkroom Color Analyzer	89
CB New Products	50	Power Antique Radios	81	555 Tester	95
		CB Battery Charger	83		

Hobby Electronics Newsletter
see page 85



wire wrapping center...

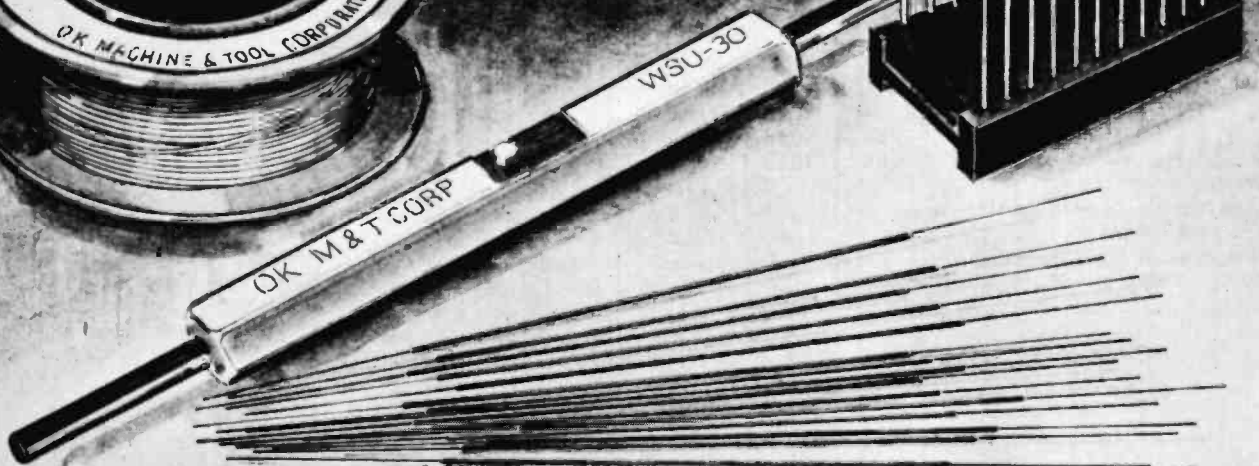
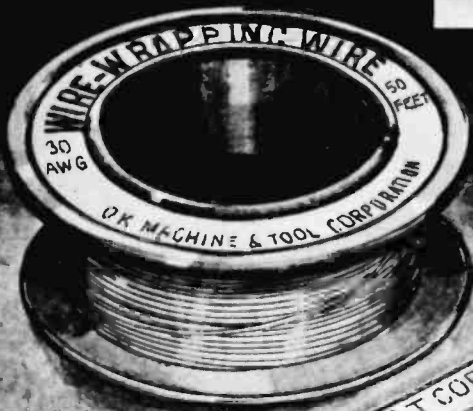

for quality electronic parts and tools.

OK MACHINE & TOOL CORPORATION
3455 Conner St., Bronx, N.Y. 10475 / (212) 994-6600 / Telex 125091

WHO'S WHO ON
101
ELECTRONIC PROJECTS
FOR UNDER \$15

Electronics Group Coordinator and Editor-in-Chief
Julian S. Martin, WA2CQL/KGK3915
Managing Editor
Morgan W. Godwin, W4WFL
Assistant to Editor-in-Chief
Alan H. Rose, K2RHK
Technical Editor
Charles Graham, W1HF1
Audio Editor
Christine Begole
Citizens Band Editor
Kathi Martin, KGK3916
Editorial Assistant
Sandra Barack
Workbench Editor
Hank Scott
Art Director
Ralph Rubino
Assistant Art Director
Augustus Ginnocchio
Art Assistants
Joni Erlon
Bob Modero
Caroline Imparato
Production Director
Carl Bartee
Production Manager
Carole Dixon
Assistant Production Manager
Geri Brakatselos
Advertising Director
David J. Miller, KCX1268
Advertising/Research Associate
Jyll Holzman
Newsstand Circulation Director
Don Gabree
Director of Market Development
James C. Weakley

President and Publisher
Joel Davis
Vice President and General Manager
Leonard F. Pinto
Vice President and Treasurer
Victor C. Stabile, KBP0681



101 ELECTRONIC PROJECTS is published annually by Davis Publications, Inc. Editorial and business offices: 229 Park Avenue South, New York, N.Y. 10003. Advertising offices: New York, 229 Park Avenue South, 212-OR 9-1300; Chicago, 520 N. Michigan Ave., 312-527-0330; Los Angeles: J. E. Publishers' Rep. Co., 8732 Sunset Blvd., 213-659-3810.

EDITORIAL CONTRIBUTIONS must be accompanied by return postage and will be handled with reasonable care; however, publisher assumes no responsibility for return or safety of manuscripts, artwork, or photographs. All contributions should be addressed to the Editor-in-Chief, 101 ELECTRONIC PROJECTS, 229 Park Avenue South New York, N.Y. 10003.

Copyright 1977 by
Davis Publications, Inc.



Got a question or a problem with a project—ask Hank! Please remember that Hank's column is limited to answering specific electronic project questions that you send to him. Personal replies cannot be made. Sorry, he isn't offering a circuit design service. Write to:

Hank Scott, Workshop Editor
101 ELECTRONIC PROJECTS
229 Park Avenue South
New York, NY 10003

Blanking Out Noise

You hear so much about noise blankers, but no one explains them. How about you, Hank!

C.M., Baton Rouge, LA

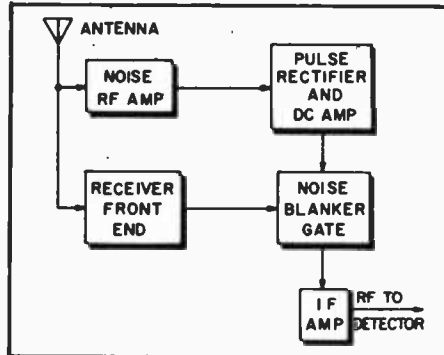

The noise blanker circuit is inserted ahead of the detector as shown in the diagram. When a noise pulse is received at the antenna, it is amplified by the noise RF amplifier and then converted into a DC pulse which is fed to an electronic noise blanker gate circuit. When a noise pulse occurs, a DC pulse supplied to the gate "punches" a hole in the IF signal killing the noise pulse in the received signal—in fact, killing all the signal for that instant in time. The blanked out section of the IF signal is so short in duration that the listener cannot hear it. Even better, the annoying noise pulse is gone, allowing more pleasant listening for the operator.

Kathi Gets a "Dear Kathi"

It's really true that one never stops learning. I've been up to my neck all my life in communications (including domestic-intrigue) and not surprisingly, I'm currently a guest of the Federal Prison System. I service equipment and occasionally teach here. Since it came into common use, I've failed to successfully explain the operation of noise-blanking (to the anguish of my understudies). I want to express my gratitude to you for simplifying the explanation of it like none before you (September/October e/e). Right On!

You made teaching this function measurably easier and make me glad I'm from the "Big-Apple." Oh, by the way, we had the print-shop guy do a wall-poster blowup of the "buzzin' bee" on page 28, because it looks amazingly like us. Send us a better flick of you so we can pin it up everywhere. Keep on teaching! 3s,

—Gino & the guys, San Pedro, CA

You guys are in for a treat! Kathi informs me that a photo is in the mail. And we all wish you the best of luck. Should

any of our readers want to "pen pal" it with Gino and the boys, write to ol' Hank asking for the address.

BFO For SSB

I have an old receiver that cannot receive SSB signals and make sense. Some one told me that I can use the BFO control to pull in SSB. Is this so?

—R.G., Hunter, NY

You can. Tune in the station for loudest sound. Then turn on the BFO switch and rotate the control as you rock the tuning knob. It can be done, but if you want to seriously monitor SSB stations, get a new receiver with a product detector to receive the sideband signals.

It Takes Time

How come you guys use last year's catalogs? What's wrong with the 1977 ones?

—K.K., Brooklyn, NY

Nothing, in fact we prefer the latest catalogs whenever we specify parts and equipment. However, we work on the early 1977 issues in 1976 before the catalogs come out. Hope you understand.

Hi, Old Timer

I found White's Radio Log in the back of COMMUNICATIONS WORLD which you publish. I haven't seen White's in more than 30 years, it was like finding an old friend. I remember in the old days the listing included network affiliations. Why not now?

—O.B., Miami, FL

Network affiliations are not as important today as they were years ago. There are a lot more independents in AM than ever before. FM is practically non-network. Only TV remains, and even now many TV stations are independents that pick the best of two or more networks.

AM/FM/TV Address Book

I am a long-time shortwave listener and now I'm getting into the BCB band. I have one problem. I don't know where to get the address of stations. I own the World Radio-TV Handbook, but that only gives me the address of stations broadcasting with 10,000 watts and 50,000 watts. Can you help me?

—S.S., Carlsbad, NM

I always write to the station and use the city and state as the only address. For small towns this works fine. Large city post offices are a bit tougher. They are apt to return your letter. But I am persistent,

and write again. I once had a tough time with a Los Angeles post office, so I sent the letter to an amateur in L.A. whose name I took out of the Radio Amateur Call Book, and asked him to forward the letter by adding the street address he could easily obtain from the local telephone book. It worked. Lots of nice people out there. Of course, there is the Broadcasting Yearbook which is published annually by Broadcasting Publications, Inc., 1735 De Sales Street, N.W., Washington, D.C. 20036. The Yearbook costs \$25.00 prepaid.

Like Everyone's Sister

Every time I turn on my CB, my sister washes her hair, and uses a detangler on it—which is great for her, but murder on my ears when I try to listen to my radio. Is there a simple filter I could put in the AC line to get rid of the hash?
—D.B., Belleville, IL

Install a small disc capacitor in the detangler that's about .01 uF. If that doesn't work, have your sister plug the unit into a line filter at the outlet. This may help. Otherwise, have her think Kojak.

Thank You

Thank you for including my query for a manual for the Hallicrafters S-38E short-wave radio in a recent issue. Not only did I get one, but also offers of help. My thanks to you and the nice people who read your column.
—R.F., Cohasset, MA

We can't print all the thank yous we receive for our help wanted column, but this one is typical.

Please Ease Off, Fellows

Hank, you didn't answer my last two letters. Everything okay with you?
—D. N., Waverly, TN

Yes, except no one listens to me! I cannot answer letters. I can only read them and answer only those which are typical of many received in my column. So please, don't send stamped, self-addressed envelopes or postcards. There are not enough hours in the day to answer all my readers' letters personally.

Pumps RF Also

My 1974 Vega has an electric fuel pump that makes about an S9 racket in my CB set. The pump is located inside the fuel tank so I assume it uses an oscillator in place of an interrupted contact to drive it. I have tried all the usual types of filters and bypass cures, but to no avail. I also contacted General Motors Service and got nothing there except a large telephone bill. Can you help?

—R. L., Lowell, IN

The trouble may be your antenna coax line. Check it very carefully. The fuel pump lines pass through the trunk. As a quick check, turn on your direction lights. If you hear the clicking, your antenna line is defective. Otherwise, you may have to take the CB power line directly to the battery instead of the accessory power line. Can anyone else suggest a remedy?

(Continued on page 99)

WRITE NOW FOR **McGEE'S**
BIG SPEAKER CATALOG
1001 BARGAINS IN
SPEAKERS—PARTS—TUBES—HIGH FIDELITY COMPONENTS—RECORD CHANGERS
Tape Recorders—Kits—Everything in Electronics
1901 McGee Street, Kansas City, Missouri 64108

Let's Clean Up America For Our 200th Birthday



Sponsor an environmental improvement. Write: Johnny Horizon '76, U.S. Department of the Interior, Washington, D.C. 20240
This space donated as a public service

NEW

FROM 

THE **HOBBY~WRAP**
COMPLETE WITH BIT AND SLEEVE
ONLY **\$34⁹⁵**



Model **BW-630**



Now you, the hobbyist, can do wire-wrapping professionally with our easy to use Hobby-Wrap gun.

OK MACHINE & TOOL CORPORATION
3455 Conner St., Bronx, N.Y. 10475 / (212) 994-6600 / Telex 125091

.025 sq. post, AWG 30 wire (batteries not included)

Our 8 Most Popular Bicentennial Craft Projects

Craft plans are the hottest thing going today! And here are eight of our winning designs! They're popular because more and more spare-time craftsmen—and people who are discovering they have talent—have found a great way to own something they have always wanted. And have fun besides. Well-known designers have developed these easy-to-follow plans that give you beautiful, finished pieces to enjoy at a fraction of the retail store price!

Get started now by ordering one or more of these award-winning Bicentennial Craft Plans. They're only \$2.50 each!

A
W
A
R
D

W
I
N
N
E
R
S



DOUBLE-DUTY TABLE LAMP D-9

Add an elegant touch to your bedroom or living room with this colonial-style table lamp and clock duo. You need just a few pieces of pine. Simple wiring for both electric clock and lamp. Clock features a sweep second hand and alarm.



DROP-LEAF TABLE D-19

Here's a versatile furniture piece that's easy to construct—even for the beginning craftsman. Build it from the lumber of your choice. It's a neat little drop-leaf table, inexpensive but big in value. Fits easily any nook or available space.



DUAL-PURPOSE GAME TABLE D-15

You can build this handsome game table easily using poplar and mahogany woods for under \$30. It will give you many hours of pleasure. Primarily a game table, it features a solid block chessboard made of light and dark-colored squares, easily made and glued together. Has leatherette panels and a roomy drawer.



BAR CABINET D-5

There's no finishing to do on this little dandy—prefinished fruitwood wall panel takes care of that. Front section converts into a handy sewing tray. Has ample storage space for bottles, glassware, ice bucket, etc. Prefinished cove molding edges the lid and base.



DRY-SINK HUTCH D-14

Add a touch of Americana with this attractive, interesting and easy-to-make dry-sink hutch. It is entirely made of 3/4" pine except for plywood backing. Special casters make it mobile. Buttons, dowels, casters, etc.—all specialty items—are available complete from one source.



BINGO WALL CLOCK D-12

A functional and decorative timepiece. You can easily make the case from pine. Has a battery-operated movement. Moldings are standard and available at lumber yards. Turned finial, decorative eagle and clock works are available from one source. Simply saw out the design and shape the edge.



DROP-LEAF SECRETARY D-24

A sturdily built, Early American desk with plenty of storage room. Lumber used for this is common pine. Cost about \$50—commercially made unit retails for about \$340. You can't afford not to build this beauty!



LIBRARY WALL CABINET D-28

A useful piece of furniture. Easily built out of common pine andluan panels for under \$30! Offers shelves above for books and curios and storage cabinets below. Each unit easily constructed and butt joints used throughout. With exception of the door panels and decorative arched valance, all cutting is straight and simple.

B
E
S
T

S
E
L
L
E
R
S

Great! New! Money-saving! Easy-to-build Craft Plans!

BICENTENNIAL CRAFT PLANS
Davis Publications, Inc.
229 Park Avenue South
New York, N.Y. 10003

Complete and mail today!
OUR GUARANTEE:
Money back if not
completely satisfied!

I have checked the appropriate box below and have enclosed payment. ALL PLANS \$2.50 each, plus 50¢ for one plan (first-class) postage and handling, two or more \$1.00.

- D-5 D-9 D-12 D-14 D-15 D-19 D-24 D-28

Enclosed is a total of \$_____ (check or money order).

Name _____ Address _____
(please print)

City _____ State _____ Zip _____

New Products

Communications Rotor

The Cornell-Dubilier communications rotor system, Big Talk, combines accuracy, ease of operation and quietness. The stained wooden cabinet Big Talk control box enables the operator to preset four rotor positions for instant selection with push buttons. The four most used positions can be identified by the snap-off, etched button cover. The settings and identification can be changed at the operator's discretion. A dial control offers a 360° scale for rotation to "zero in" on a signal from any direction. Both dial and preset buttons are activated by a Start Button that positions the rotor to the selected direction and

automatically shuts off all power. A neon light illuminates when the power is on and the antenna is turning. The Big Talk rotor is encased in a "bell" housing of cast aluminum for complete weather protection. The powerful motor, 800 inch-pounds of stall torque, turns heavy antennas even under severe wind and ice conditions. A disc brake holds the antenna securely in a stopped position, and 50 ball bearings help rotate up to 500 lbs. of balanced weight. It requires 115 Volts AC, 50/60 Hz, and weighs 17.5 lbs. Sells for \$109.95. For further information, write to Cornell-Dubilier Electric Corporation, 150 Avenue L, Newark, NJ 07101.



CIRCLE 49 ON READER SERVICE COUPON

system is dual-ratio planetary control. The receiver features sensitivity of less than 0.5 microvolt at 50 ohms for 10-dB signal plus noise-to-noise ratio. Audio output is 4-watts to 3.2-ohm load. The 700CX is priced at \$649.95. More information can be had by writing to Swan Electronics, 305 Airport Road, Ocean-side, CA 92054.



CIRCLE 57 ON READER SERVICE COUPON

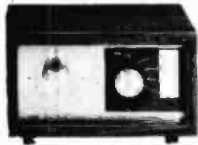

10 to 80 Meter Ham Rig

Swan Electronics has a new 700-watt P.E.P. single sideband transceiver. Called the 700CX, it features up to 10 channels for MARS operation with optional Swan 510-X plug-in crystal controlled oscillator. Frequency ranges are: 80 meters (3.5-4.0 MHz), 40 meters (7.0-7.45 MHz), 20 meters (14.0-14.45 MHz), 15 meters (21.0-21.45 MHz), 10 meters (28.0-29.70 MHz). Modes of operation are selectable LSB, USB, or CW. Calibrator is built-in selectable 25 or 100 kHz. The unit measures 5.5-in. x 13-in. x 11-in.; weight is 17.25 lbs. Audio band-pass is 300 to 3000 hertz. The tuning

Dig It Multimeter

Looking at numbers is easier and less apt to cause reading errors than reading a meter's pointer. This becomes obvious when you see B&K-Precision's Model 283. It's a 3½-digit multimeter priced at \$170 that uses high intensity, high reliability 0.41-in. LED displays that can be easily read in brightly lit rooms at a distance of at least six feet. The 283 measures DC volts, AC volts, DC current, AC current and resistance. A special low voltage circuit permits measuring resistance of transistor-shunted resistors. The Model 283 has 100 percent overrange

(Continued on page 14)

IN WIRE-WRAPPING HAS THE LINE...

HOBBY-WRAP-30 WIRE-WRAPPING, STRIPPING, UNWRAPPING TOOL FOR AWG 30 (.025 SQUARE POST)

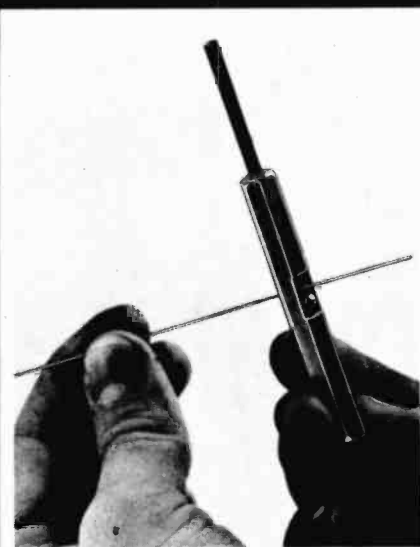

STRIP



WRAP



UNWRAP

\$5.95

SHIPPING CHARGE \$1.00
RESIDENTS ADD SALES TAX

OK MACHINE & TOOL CORPORATION

3485 CONNER STREET, BRONX, NEW YORK, N.Y. 10475 U.S.A. • PHONE (212) 994-8600

TELEX: 125091 TELEX: 232395

EVERY PROJECT ANOTHER REASON TO

Whether you're a hobbyist or serious experimenter, CSC's line of precision digital/electronics design and testing equipment can take the manual labor out of your labors of love.

In fact, we can not only save you literally hundreds of hours a year, but *hundreds of dollars* as well. On parts, accessories and test equipment.

Want proof? Read on — you'll see why we're the fastest-growing company in the field!

QT Sockets and Bus Strips* — time-saving, money-saving solderless breadboarding — the CSC way

Our expandable, interlocking breadboarding system not only saves you hours of soldering, desoldering and resoldering, it also saves wear and tear on your components.

Resistors, capacitors, transistors, DIP's, LED's, micro-processors, etc., all connect with plug-in, plug-out ease. *Preassembled sockets with durable nickel-silver non-corrosive 5-point terminals* provide low-resistance interconnections you can arrange and rearrange at will. (And jumpers, where required, are short lengths of solid #22-30 AWG wire.)

Use QT Sockets and Bus Strips for designing, troubleshooting, interconnecting, patching and dozens of other applications. Our unique snap/lock mechanism joins units in seconds, so you can add-on or take-off at will.

Check the chart below for sizes and prices.
10 modestly-priced models to choose from — still at our original low prices.
All can be top or through-the-panel rear mounted.

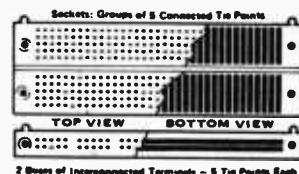
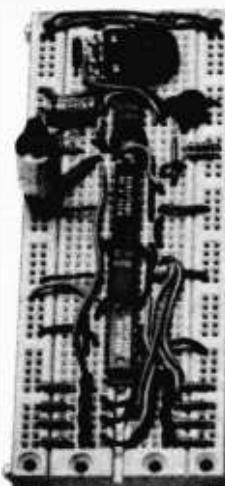

Length Hole - to-Hole	Length	Hole - to-Hole	Terminals	Unit Price \$	
	QT-59S	6.5"	6.2"	118	12.50
	QT-59B	6.5"	6.2"	20	2.50
	QT-47S	5.3"	5.0"	94	10.00
	QT-47B	5.3"	5.0"	16	2.25
	QT-35S	4.1"	3.8"	70	8.50
	QT-35B	4.1"	3.8"	12	2.00
	QT-18S	2.4"	2.1"	36	4.75
	QT-12S	1.8"	1.5"	24	3.75
	QT-8S	1.4"	1.1"	16	3.25
	QT-7S	1.3"	1.0"	14	3.00

*U.S. Pat. No. 235,554

All Prices Shown Are Manufacturer's Recommended List. Prices and Specifications Subject to Change Without Notice.

CONTINENTAL SPECIALTIES CORPORATION
44 KENDALL STREET/ BOX 1942
NEW HAVEN, CT 06509



CIRCLE 9 ON READER SERVICE COUPON

IN THIS MAGAZINE IS READ THIS AD.

**Build projects, test circuits, check components as fast as you can think...
with CSC Proto-Board® Solderless Breadboards!**

The right size for every circuit! The CSC Proto-Board system gives you the convenience and versatility of QT Bus Strips and Sockets *already mounted*, in use-tested configurations, on sturdy metal ground/baseplates** with non-marring feet. They're great for a wide variety of audio and digital projects, and you save money by using components over and over again.

PB-101—940 solderless tie points: ten 14-pin DIP capacity. Two QT-35S breadboarding sockets plus four QT-35B bus strips. Excellent for audio and smaller digital projects. Measures 4.5" wide x 5.8" long x 1.4" high (114 x 147 x 35mm); weighs 9 oz. (.26 Kg). **Price: \$29.95**

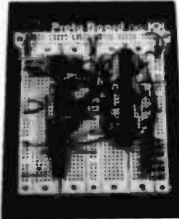

PB-102—1240 solderless tie points: twelve 14-pin DIP capacity. Two QT-47S breadboarding sockets, three QT-47B and one QT-35B bus strips. You'll want this one for intermediate digital needs, more complex audio projects among other things. Measures 4.5" wide x 7" long x 1.4" high (114 x 178 x 35mm); weighs just 10 oz. (.31 Kg). **Price: \$39.95**

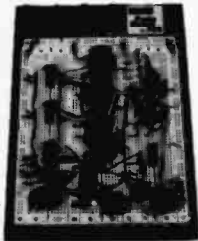
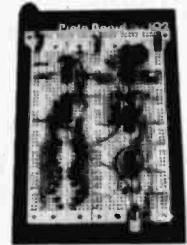

PB-103—2250 solderless tie points: twenty-four 14-pin DIP capacity. Three QT-59S breadboarding sockets, four QT-59B and one QT-47B bus strips plus four 5-way binding posts. For all but the very largest circuits. Lets you build calculators, interfaces, complex switching circuits, etc. Measures 6" wide x 9" long x 1.4" high (152 x 229 x 35mm); weighs 1.25 lb. (.57 Kg). **Price: \$59.95**

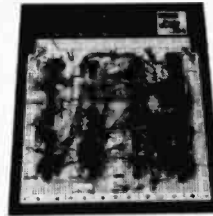

PB-104—3060 solderless tie points: thirty-two 14-pin DIP capacity. Four QT-59S breadboarding sockets, seven QT-59B bus strips plus four 5-way binding posts. It's the largest breadboard we made for the largest projects you care to tackle—a CPU, encoder, complex display... just about anything. Measures 8" wide x 9.8" long x 1.4" high (203 x 248 x 35mm); weighs 1.75 lb. (.79 Kg). **Price: \$79.95**

Save even more with Proto-Board Kits! Invest ten minutes of your time, using nothing more than a screwdriver and a pair of pliers, and you can have all the time-saving, money-saving features of CSC's Proto-Board system, for even less money! CSC Proto-Board Kits come with all hardware, non-marring feet and sturdy base-plate. And unlike other kits, *all sockets are pre-assembled*, eliminating tedious assembly and assuring long, trouble-free life.

PB-6 Kit—630 solderless tie points: six 14-pin DIP capacity. Most economical way to take advantage of Proto-Board speed and convenience. One pre-assembled QT-47S breadboarding socket, two assembled QT-47B bus strips, four 5-way binding posts, metal ground/plane/base-plate, all required hardware. 10 minute assembly with pliers and screwdriver. Measures 6" long x 4" wide x 1.4" high (152 x 102 x 34mm); weighs 7 oz. (.20 Kg). **Price: \$15.95**



PB-100 Kit—760 solderless tie points: ten 14-pin DIP capacity. 21% larger capacity than PB-6 Kit. Comes with two pre-assembled QT-35S breadboarding sockets, one assembled QT-35B bus strip, two 5-way binding posts, pre-drilled and screened base-plate, non-marring feet and all required hardware. Fast 10 minute assembly. Measures 4.5" wide x 6" long x 1.4" high (114 x 152 x 35mm). Weighs 7.5 oz. (.21 Kg). **Price: \$19.95**



Now! Proto-Board convenience, plus regulated power! No need to hunt for a power supply when you're working with these CSC Proto-Board units. Built-in power supplies give you the DC power you need, with laboratory-precision regulation, plus low ripple and noise. Choose the PB-203 for digital circuits and other projects requiring 5V or less (with external components) or for maximum flexibility, the PB-203A, with 5VDC plus two independently-adjustable voltage sources.



PB-203—2250 solderless tie points: twenty-four 14-pin DIP capacity. The Ultimate! All Proto-Board features *plus* short-proof, fused 5VDC, 1A regulated power supply with only 10mV ripple and noise at 0.5A; on-off toggle switch and pilot light. Three QT-59S breadboarding sockets plus four QT-59B and one QT-47B bus strips. Power supplied via two of the four 5-way binding posts. It all

adds up to lots of capacity plus the proper DC voltage for most digital and many analog IC's. Measures 9.75" long x 6.6" wide x 3.25" high (248 x 168 x 83mm). Weighs 5 lb. (2.27 Kg). For 117 VAC, 50/60 Hz (220 VAC, 50/60 Hz; also available at slightly higher cost). **Price: \$75.00**

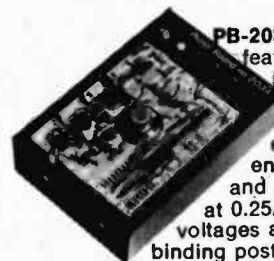

PB-203A—The Ultimate... plus!! All the features of the PB-203 including regulated 5VDC supply *plus* additional power supply flexibility (separate regulated +15VDC and -15VDC, 0.5A supplies, each with internally and independently adjustable output voltage; ripple and noise of + and -15V supplies, 10mV at 0.25A). Connections for 3 power supply voltages and ground available at four 5-way binding posts. Same size as PB-203; weighs 5.5 lb. (2.5 Kg). For 117 VAC, 50/60 Hz (220 VAC, 50/60 Hz; also available at slightly higher cost). **Price: \$120.00**

**PB-100 has fibreglass-reinforced plastic baseplate.

**TURN PAGE FOR MORE CSC PRODUCTS
AND EASY ORDER FORM**

8 MORE WAYS TO DO IN A LOT LESS TIME-FOR

CSC's Design-Mate™ Series. Laboratory precision at a hobbyist's price.

We knew what you were looking for when we created the Design-Mate Series. So we put the emphasis on laboratory precision and professional performance instead of needlessly expensive fancy cabinetry. Check it out! Check it all out!

DESIGN-MATE 1 BREADBOARD/CIRCUIT DESIGNER

Design-Mate 1 gives you everything you need for fast, easy solderless circuit design in a single compact package. QT speed and versatility for circuit design and modification as fast as you can push in (or pull out) a lead, using one QT-59S breadboarding socket and two QT-59B bus strips, mounted on the top panel. Adjustable, precision-regulated 5-15 VDC 600 mA short-circuit-proof fused supply, with less than 20 mV noise and ripple at rated output (9W max.). Built-in 0-15VDC meter lets you monitor voltages in circuit or supply. Top panel supply and meter connections are easily made via four 5-way binding posts; on-off and voltage adjustment controlled by potentiometer; bright LED indicates power. Measures 7.5" wide x 6.5" deep x 3.25" max. high (191 x 165 x 83mm); weighs 3 lb. (1.4 Kg). For 117 VAC, 50/60 Hz (12W); also available for 220 VAC, 50/60 Hz at slightly higher cost. **Price: \$54.95**

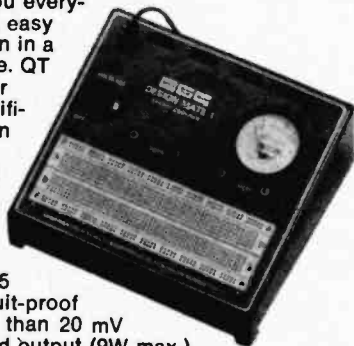

DESIGN-MATE 2 FUNCTION GENERATOR

Design-Mate 2 gives you a lot of signal generator for very little money. Advanced IC circuitry produces stable low-distortion sine waves (less than 2% THD), fast-rise-and-fall-time square waves (less than 0.5 micro-seconds across 600 ohms) and high-linearity triangle waves (better than 1% over range). Frequency is accurate—and repeatable—to 5% of dial setting, in 5 ranges: 1-10Hz, 10-100Hz, 100Hz-1KHz, 1-10KHz, 10-100KHz. Shortproof output is adjustable, 100mV-10V P-P for all waveforms, into open circuit. **Controls, switches, indicators and connectors:** toggle power switch with LED indicator; function selector switch; range switch; frequency selector dial (1-10 in 100 increments); amplitude control; twin 5-way binding posts. Measures 7.5" wide x 6.5" deep x 3.25" high (191 x 165 x 83mm); weighs 2 lbs. (0.91 Kg). For 117 VAC, 50/60 Hz; also available for 220 VAC, 50/60 Hz at slightly higher cost. **Price: \$69.95**



DESIGN-MATE 3 R/C BRIDGE

Design-Mate 3 is an indispensable tool for professionals and hobbyists alike. Makes precision resistance and capacitance measurements in seconds, with positive LED indication. Readings are accurate within 5% of the dial setting at any range—resistance: 10-100 ohms, 100-1K, 1K-10K, 10-100K, 100K-1 meg; Capacitance: 10-100pF, 100-1,000pF, .001-.01μF, .01-1μF, .1-1μF. Simple 2-control operation: set range with switch, then turn Null Adjust dial until both LED are lit. **Switches, controls, indicators and connectors:** toggle power switch with LED indicator; range selector switch; Null Adjust dial (1-10 in 100 increments); LED null indicators; twin 5-way binding posts. Measures 7.5" wide x 6.5" deep x 3.25 max. high (191 x 165 x 83mm); weighs 2 lbs. (0.91 Kg). For 117 VAC, 50/60 Hz; also available for 220 VAC, 50/60 Hz, at slightly higher cost. **Price: \$59.95**



DESIGN-MATE 4 MULTIPURPOSE PULSE GENERATOR

Design-Mate 4 is a multi-purpose, multi-mode pulse generator providing pulses from 0.5Hz-5MHz, rise and fall times less than 30 nsec and 10⁷:1 duty cycle range, compatible with CMOS and TTL. It provides the precision, flexibility and versatility of a laboratory instrument, priced low enough for the workbench of every engineer, technician, student and hobbyist who works with digital circuitry. Its unique combination of performance and price makes it ideal for a wide variety of applications throughout the electronics industry. Design-Mate 4 may be used as a clock source, delayed pulse generator, synchronous clock source, manual system stepper, pulse stretcher, clock burst generator, in tandem with one or more DM-4's used to gate the output of one or more additional DM-4's. **Price: \$124.95**



COMPLETE INSTRUCTIONS AND APPLICATION DATA PROVIDED!!

All Prices Shown Are Manufacturer's Recommended List. Prices and Specifications Subject to Change Without Notice.

A LOT MORE PROJECTS- A LOT LESS MONEY.

CSC's Digital testers save your sanity. And your money.

New! LP-1. It digs up a lot of information for \$44.95. Logic Probe 1 is a compact, versatile design, test and trouble-shooting tool for all popular logic families and digital applications. By connecting the clip leads, setting a switch to the proper logic family and touching the probe to the node under test, you get an instant picture of circuit conditions. LP-1 combines the functions of level detector, pulse detector, pulse stretcher and memory—makes one-shot, low-rep-rate, narrow pulses—nearly impossible to see, even with a fast scope—easily detectable and visible.

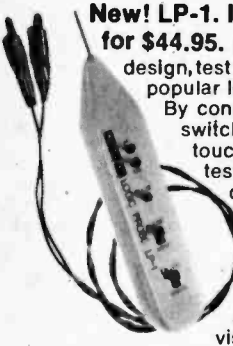



LM-1. It lets you check digital IC's faster than a scope, safer than a voltmeter, for a lot less than you might guess—only \$74.95. Logic Monitor™ 1 speeds digital design and testing by accurately and automatically displaying static and dynamic logic states of DTL, TTL, HTL and CMOS DIP IC's. All in a compact, self-contained 16-pin circuit-powered unit. Use it to effortlessly trace signals through counters, shift registers, gating networks, flip-flops, decoders, etc. Clip it over any DIP IC up to 16 pins, and each contact connects to a single "bit" detector with high-intensity LED readout. Logic 1 (high voltage) turns LED on; Logic "0" (low voltage or open circuit) keeps LED off. A power-seeking gate network automatically locates supply leads and feeds them to the Logic Monitor's internal circuitry.

Proto-Clip™* IC Test Clips pay for themselves the very first time you use them.

Use Proto-Clip Connectors By Themselves...

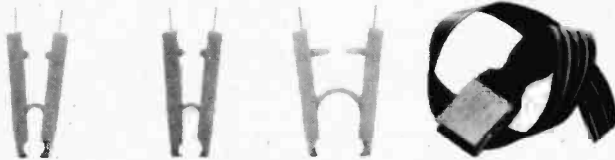

Or With
Pre-Wired
Cables



PC-14 (14-pin Proto-Clip) \$4.50 each
PC-16 (16-pin Proto-Clip) \$4.75 each
PC-24 (24-pin Proto-Clip) \$8.50 each

The reason's as simple as the time you'll save testing, signal tracing or wiring in DIP's. Not to mention the cost of IC's ruined by accidental shorts. A Proto-Clip is the foolproof, short proof way to bring up leads from crowded circuit boards. Its patented, molded design and unique gripping teeth free hands for other work. Built to withstand tough day-to-day use, CSC clips are available with or without cable for 14- 16- and 24-pin DIP's starting at \$4.50.

	Cable length inches	Price Single clip	Price Dual clip
PC-14-	12	7.50	14.50
PC-14-	18	7.75	14.75
PC-14-	24	8.00	15.00
PC-14-	30	8.25	15.25
PC-14-	36	8.50	15.50
PC-16-	12	8.25	15.75
PC-16-	18	8.50	16.00
PC-16-	24	8.75	16.25
PC-16-	30	9.00	16.50
PC-16-	36	9.25	16.75
PC-24-	12	12.00	25.00
PC-24-	18	12.25	25.25
PC-24-	24	12.50	25.50
PC-24-	30	12.75	25.75
PC-24-	36	13.00	26.00

NOTE: S=single clip (on one end of cable); D=dual clips (on both ends of cable). When ordering Proto-Clip units with cable, include Part No., cable length and Single (S) or Dual (D)—for example: PC-16-24-D is 24" cable with a PC-16 at both ends.

*U.S. Pat. No. 3,914,007

CONTINENTAL SPECIALTIES CORPORATION 44 KENDALL STREET P.O. BOX 1942 NEW HAVEN, CT 06509		24 HOUR SERVICE		FOR OFFICE USE ONLY			
NAME _____ STREET ADDRESS _____ CITY _____ STATE _____ ZIP _____		ORDER FORM		No. _____			
This is your shipping label. Please print clearly.				QTY. Stock Number Unit Price Total Price		\$ ¢ \$ ¢	
FOUR FAST, EASY WAYS TO ORDER		The CSC Guarantee: We guarantee complete satisfaction, or your money back. Return unsatisfactory merchandise prepaid within 10 days for full refund.		TOTAL		Conn. QR Calif. Sales Tax	
<input type="checkbox"/> Include payment (\$5.00 min.) <input type="checkbox"/> C.O.D. U.S.A. only. You pay postage and fees. <input type="checkbox"/> Charge (\$10.00 min.) Please fill in below.		<input type="checkbox"/> I have <input type="checkbox"/> I have not purchased from CSC before.		POSTAGE & HANDLING CHART		Add—	
AMERICAN EXPRESS <input type="checkbox"/> Bank No. _____ BANK AMERICARD <input type="checkbox"/> 4 numbers above your name _____ MASTER CHARGE <input type="checkbox"/> Credit Card No. _____		_____ _____ _____		up to \$10.00 \$1.50 \$10.01-25.00 2.00 \$25.01-50.00 2.50 \$50.01 & over 3.00		_____ _____ _____	
<input type="checkbox"/> In a hurry? Telephone! East Coast—203-624-3103 West Coast—415-421-8872		_____ _____ _____ Signature		_____ _____ _____		TOTAL AMOUNT ENCLOSED	
_____ _____ _____		_____ _____ _____		_____ _____ _____		_____ _____ _____	

Prices, specifications and conditions of sale are subject to change without notice.

New Products



CIRCLE 62 ON READER SERVICE COUPON

capability on four ranges, so that one can read to 199.9 on a scale that is normally set for 100.0 maximum. Out-of-range is indicated by a flashing digit and three zeros. All readings have an automatically positioned decimal point. Overload protection is provided, up to 1000V on the ohms, 1500V on the voltage ranges, and 3A on current shunts. An optional battery pack provides 8 hours operation on an overnight charging. Batteries also charge when the Model 283 is used on 110 VAC line. For additional information, write to Myron Bond, B&K-Precision, 6460 W. Cortland, Chicago, IL 60635.

Keep the Record Clean

Watts Manual Parastat will soon be available in MKIIB configuration, housed in a transparent dust proof storage box. The Manual Parastat was specifically designed for use with older records which have been treated with anti-static fluid or which have an excessive accumulation of dust, dirt or residue in their grooves. By design, the Manual Parastat has a dual function. It may be used as a Preener if tilted to either side, since each side is designed like the famed Watts Preener. As such, it may be used for the maintenance of new records.

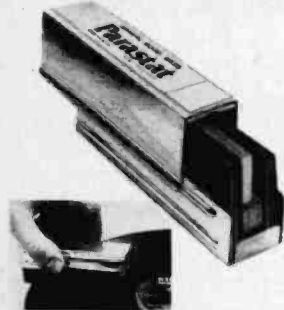

CIRCLE 53 ON READER SERVICE COUPON

Watts Parastat may also be used as a cleaner for old records when held in an upright position so that the nylon bristles between the two Preeners penetrate the record grooves to loosen and remove accumulated dirt and grit. The brush of the Watts Manual Parastat is made of pure nylon bristles with an average tip radius of 0.00025 inches. This assures deep penetration to the walls and sides

of the record grooves. Priced at \$14.95. Distributed by Elpa Marketing Industries, Inc., 301 Atlantic Avenue, New Hyde Park, NY 11040.

Digital Color Dot/Bar Generators

Science Workshop has a feature-packed portable Color Alignment Generator. The Model DB-12 uses an IC chip which is a complete TV signal generating system. All of the sync, blanking and video signals are derived from the master clock by digital counters in the chip. This eliminates the drift and jitters that other types of generators have. Using digital switching techniques, only four slide switches select any one of 16 patterns in accordance with the digital

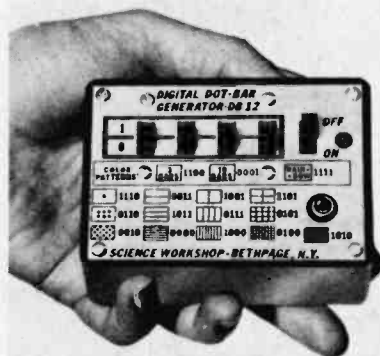

CIRCLE 47 ON READER SERVICE COUPON

code screened on the front panel of Model DB-12. The unique oscillator/modulator stage provides both rf and video from the same output jack for signal injection and signal tracing. The DB-12 is pocket size and is available in kit or wired form. Prices are: Kit \$49.95; Wired \$64.95. For further information, write to Science Workshop, Box 393, Bethpage, NY 11714.

Continuous Tuning Receiver

Yaesu has come up with the new FRG-7, an all band, fully synthesized continuous tuning solid state receiver which will have tremendous appeal to CB, shortwave broadcast and amateur band listeners plus others who want optimum performance over the tuning range of 500 kHz to 29.9 MHz. Priced at \$299.00, the FRG-7 is a fully-synthesized triple conversion superheterodyne using the "Wadley Loop System" which offers extremely stable performance. The dial calibration provides unusual dial resetability to an exact frequency. Precision selectivity is provided for SSB, AM and CW with the utilization of a ceramic filter in the 455 kHz IF circuits. The FRG-7 includes a three-step front end attenuator, amplified AGC and normal, low and high tone select switch to provide the desired audio response most pleasing to the ear. The receiver has a self contained three-way power supply for line voltages from 100 to 234 volts in six graduated steps for 50/60 cycle AC plus provision for internal battery operation off size D flashlight cells. Should there be an AC power failure, the receiver automatically switches over to the internal batteries.



CIRCLE 59 ON READER SERVICE COUPON

The receiver may also be operated by an external 12-volt battery, such as used in mobile application. There is an internal speaker provided plus headphone jack and an output jack for recording off the air. An S-meter reads relative signal strength, and is calibrated in standard S-units. Built into an attractive two-tone grey cabinet, the FRG-7 weighs just 7 kg. and measures 340 (W) x 153 (H) x 285 (D) mm. For more information, write to Yaesu Electronics Corp., P.O. Box 498, 15954 Downey Avenue, Paramount, CA 90723.

Engine Analyzer

EICO's new Model 885 "Tunemaster" Solid State Engine Analyzer is an automotive test bench in one. The 885 performs up to 16 different tests and analysis, including Ignition Points Test; Dwell Test; Dwell Variation; Low RPM (Tachometer); High RPM (Tachometer); Battery Test; Accessory Current Draw; Charging System Output; Output Test (Regulator Bypass); Voltage Loss Test; Alternator Diode Test; and Fuse Test. The 885 has a large, six-inch D'Arsonval meter with a multirange, color-coded scale for easy



CIRCLE 61 ON READER SERVICE COUPON

reading, a Cylinder Selector Switch that eliminates the need for mental extrapolation of results, and a color-coded range switch for mode selection. The unit operates from the car's battery. The instruction manual provided with the analyzer gives step-by-step tune-up information for all cars, domestic and foreign. Priced at \$49.95. For further information, write to EICO Electronic Instrument Co., Inc., 283 Malta Street, Brooklyn, NY 11207.

Cordless Soldering Station

Ungar has a new cordless quick-change soldering station. The new design allows the operator unrestricted freedom

for hard-to-reach intricate assemblies and repair. An ideal station for the professional who services radio and TV, builds electronic kits or does touch-ups and repairs in the field or at the work bench. The 200 soldering station consists of a rugged rechargeable iron with a quick charge nickel cadmium battery. It is designed to accept two rigid interchangeable tips, and the charging holder with tip cleaning sponge completely recharges the battery in 4 hours. Outstanding features of Ungar's new quick charge soldering station are: well-balanced lightweight pencil iron with indicator light, convenient easy touch operating trigger control with interlock "off" switch. A built-in lamp illuminates tip

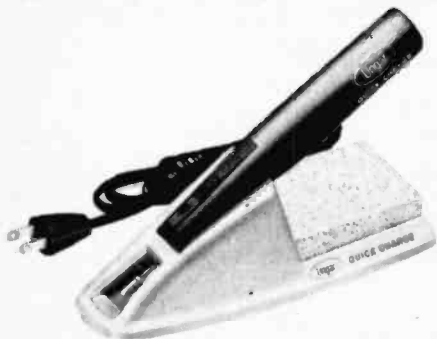

CIRCLE 38 ON READER SERVICE COUPON

and work area. Two quick heating, interchangeable element tips are available, pretinned in chisel and micro spade configuration. The charging holder allows iron to charge in rest position and provides long battery life. Holder has convenient built-in sponge tray for efficient tip cleaning and care. Priced at \$24.95. For additional information, write to Ungar, Division of Eldon Industries, Inc., 233 East Manville Street, Compton, CA 90220.

Data Handler

Ideal for computer hobbyists and anyone with an interest in computer programming, Western Data Systems has developed the Data Handler. It is a complete system on a single PC board that combines the MOS Technology 6502 microprocessor with the latest state-of-the-art technology. The Data Handler combines multi-functions with the ease

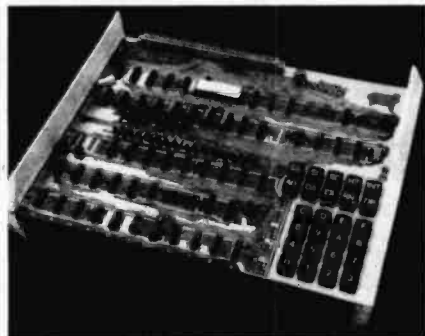

CIRCLE 55 ON READER SERVICE COUPON

of operation that makes it ideal for the beginning computer enthusiast. The Data Handler can be programmed to control any eight devices simultaneously—everything from monitoring solar heating sys-

for the Experimenter!

INTERNATIONAL CRYSTALS and KITS

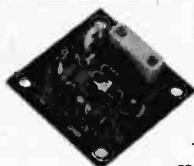

OF-1 OSCILLATOR

\$3.25 ea.

The OF-1 oscillator is a resistor/capacitor circuit providing oscillation over a range of frequencies by inserting the desired crystal. 2 to 22 MHz, OF-1 LO, Cat. No. 035108. 18 to 60 MHz, OF-1 HI, Cat. No. 035109. Specify when ordering.

.02% Calibration Tolerance

EXPERIMENTER CRYSTALS
(HC 6/U Holder)

\$4.25 ea.



Cat. No. Specifications
031300 3 to 20 MHz — For use in OF-1L OSC Specify when ordering.
031310 20 to 60 MHz — For use in OF-1H OSC Specify when ordering.

MXX-1 Transistor RF Mixer

3 to 20 MHz, Cat. No. 035105 **\$4.50** ea.
20 to 170 MHz, Cat. No. 035106

SAX-1 Transistor RF Amp

3 to 20 MHz, Cat. No. 035102 **\$4.50** ea.
20 to 170 MHz, Cat. No. 035103

BAX-1 Broadband Amp

20 Hz to 150 MHz Cat. No. 035107 **\$4.75** ea.

Enclosed payment with order in U.S. Dollars and postage (outside U.S., Canada and Mexico only) will be prepaid by International Crystal Mfg. Co., Inc. U.S., Canada and Mexico orders only. Orders for shipment to other countries will be quoted in U.S. dollars plus applicable postage. Address orders to:

Mfg. Dept. P.O. Box 3247
Oklahoma City, Oklahoma 73102

WRITE FOR BROCHURE

International Crystal Mfg. Co., Inc.
10 North Lee Oklahoma City Oklahoma 73102



CIRCLE 12 ON READER SERVICE COUPON

See advertisement on Cover 2 for complete details.
COMPLETE AND MAIL TODAY

Boat Builder 229 Park Avenue S. New York, N.Y. 10003

101EP7

Enclosed is _____. Please add 50¢ for postage and handling. Send me the Craft Print(s) I have checked below:

- #367 \$5.00 Add 50¢
- #245 \$6.00 Add 50¢
- #62 \$5.00 Add 50¢
- #371 \$5.00 Add 50¢
- #75 \$5.00 Add 50¢
- #356 \$5.00 Add 50¢
- #36 \$5.00 Add 50¢
- #343 \$5.00 Add 50¢
- #344 \$15 full-size pattern set. Add 50¢

SATISFACTION GUARANTEED.

Name _____
Address _____
City _____ State _____ Zip _____

There's Nothing Like Elementary Electronics

—America's most absorbing, down-to-earth magazine for the electronics and radio hobbyist!

Each issue brings you—

- fascinating electronic devices to build
- instructive articles on CB, electronics, shortwave, and lively columns
- a Basic Course in electronics theory
- a great Q & A column to help you with your projects or anything electrical



Our writers, editor and columnists know their stuff backwards and forwards. They make it all interesting with the same straightforward language that you use.

ELEMENTARY ELECTRONICS,
P.O. Box 2600, Greenwich CT 06830

- Bill me \$3.87 for ONE YEAR (6 issues).
- Enclosed is \$3.87. (I receive SEVEN ISSUES FOR CASH.)

Name _____ (please print)

Address _____

City _____ State _____ Zip _____

Allow 6 to 8 weeks for delivery of your first copy.

H7E039

New Products

tems and lawn sprinklers to game playing and pouring cocktails at a party. The design of the Data Handler enables it to operate at very high speeds as a stand-alone microcomputer or dedicated controller for such high speed devices as disc peripherals. External TTY or terminals are not needed, since this computer contains 26 keyboard switches for full function hardware front panel control. Personal expandability of the system is achieved by using the Altair/MSAI peripherals. Any of these may be used directly on the Data Handler PC board, or further system expansion may be accomplished with the use of the Altair mother board. The Data Handler comes in easy to assemble kit form with complete documentation on how to use, test, and expand the system. The Data Handler kit is available from Western Data Systems for only \$179.95. For further information, write to Western Data Systems, 3650 Charles Street, Suite G, Santa Clara, CA 95050.

Touch-Controlled Switch

Tired of fiddling with lamp switches? Do you just want to install a new wall switch in a more convenient place but without a lot of expense and trouble? Well, the new Heathkit Touch Switch is the answer. Simply touching the metal plate you can mount anywhere switches your lamp to half brightness. Holding it a little longer turns it to full brightness. Then, when you're ready to turn the light off, simply touch again. Installation is fast and easy. Simply plug your lamp into the Control Box, then mount the touch plate anywhere. The touch plate

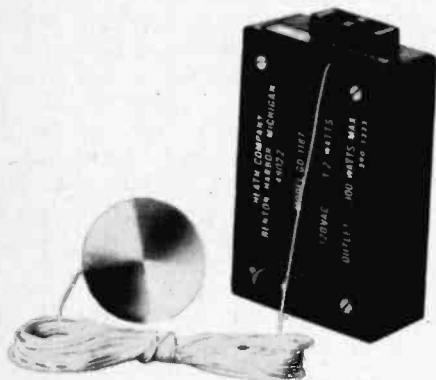

CIRCLE 31 ON READER SERVICE COUPON

is connected to the Control Box by a single, easily concealed wire—you can even use super thin "invisible" wire. And you can connect any number of touch plates to a single Control Box for added convenience. In fact, you can use any metal object as a "touch plate"—door knobs, stair railings, etc. The GD-1187 Touch Switch is mail order priced at just \$12.95 and is just one of nearly 400 electronic kits in the Heathkit Catalog. For a free copy of catalog, send your

name and address to Heath Company, Dept. 350-08, Benton Harbor, MI 49022.

Never Miss a Call

Project Support Engineering has an automatic voice actuated switching circuit for CB enthusiasts called AVASC. The AVASC installs between the car radio speaker and the CB unit. When there is no CB signal present, the car radio, tape deck, etc. will play through the car speaker. When a call comes in through the CB unit, the AVASC disconnects the car radio while simultaneously putting the CB call through the car radio speak-



CIRCLE 68 ON READER SERVICE COUPON

er. There is an adjustable time delay in the AVASC that enables the user to choose 0 to 15 seconds to compensate for any delays in the conversation. When the incoming transmission is completed, the AVASC automatically switches the car radio back on and is ready for the next transmission. The suggested retail price of the AVASC is \$29.95. Write to Project Support Engineering, 750 N. Mary Avenue, Sunnyvale, CA 94086 for complete info.

Scanner for Listener

Shortwave listening originally started with DX hounds straining their ears for any sound that could possibly be a foreign SW station, and the more distant the better. Today, SWLs have become as interested in the action on police, fire, and marine bands. Many of them now get their weather reports via NWS broadcasts and like to listen in on CB and business radiotelephone conversations. Surveyor's Model 10P Scanner, covering the VHF Hi/Lo and UHF bands, lets them get in on the action and hear it, not as some later TV news report, but as it happens. The Surveyor 10P Scanner has two facilities with great appeal to listeners. It lets the listener program easily and quickly to any frequency on the three bands. There is also a priority switch that is the listener's assurance of hearing transmission on Channel 1, even though a signal is being received on another channel at the same time. And, of course, a fully tunable squelch for complete noise control. Completely solid-state throughout, the 10P can be used at home or mobile with a power converter. Its dual conversion circuit is an assurance of knife edge selectivity, working against spillover from one chan-



CIRCLE 45 ON READER SERVICE COUPON

nel to the next. The 10P has a 10-channel capacity and all channel numbers are uncrowded and clearly visible. The unit comes equipped with an AC and DC power cord, mounting bracket, hardware and an antenna for indoor use. The suggested list price of the 10P Scanner is \$189.00. For further information, please write to Surveyor Manufacturing Corporation, 7 Electronics Court, Madison Heights, MI 48071.

FET Volt-Ohmmeter

The new solid-state drop-proof, burn-out-proof model 64 FET Volt-Ohmmeter by Triplett has six low-power ohms ranges. Battery operated, the Model 64 has an open circuit voltage of only 90 mV for fast incircuit resistance and continuity measurements without biasing or destroying sensitive diodes, ICs or transistors. The model 64 was developed for use in test laboratories, manufacturing quality control departments, field servicing, plant maintenance and vocational or trade schools. The colorful bright green 29-range tester is also easy to use

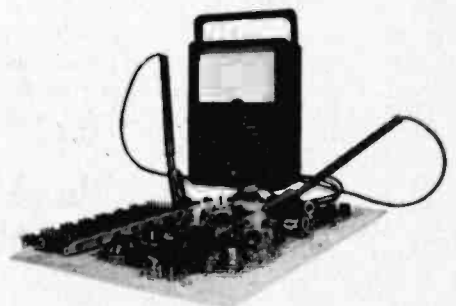

CIRCLE 51 ON READER SERVICE COUPON

with its single range selector switch. A single selector switch simplifies access to 29 ranges, including: DC Volts 0-0.3, 1, 3, 10, 100, 300, 1000; AC Volts 0-0.3, 1, 3, 10, 30, 100, 300, 1000; Ohms Low Power 0-1k, 10k, 100k, 1M, 10M, 100M; Ohms Conventional 1000M; Junction Test forward and reverse conduction. For further information on the new multi-range Model 64 Volt-Ohmmeter priced at only \$130.00, and additional accessories to extend its use in highly specialized applications, contact the Triplett Corporation, Marketing Dept., Bluffton, OH 45817.

(Continued on page 100)

101 ELECTRONIC PROJECTS

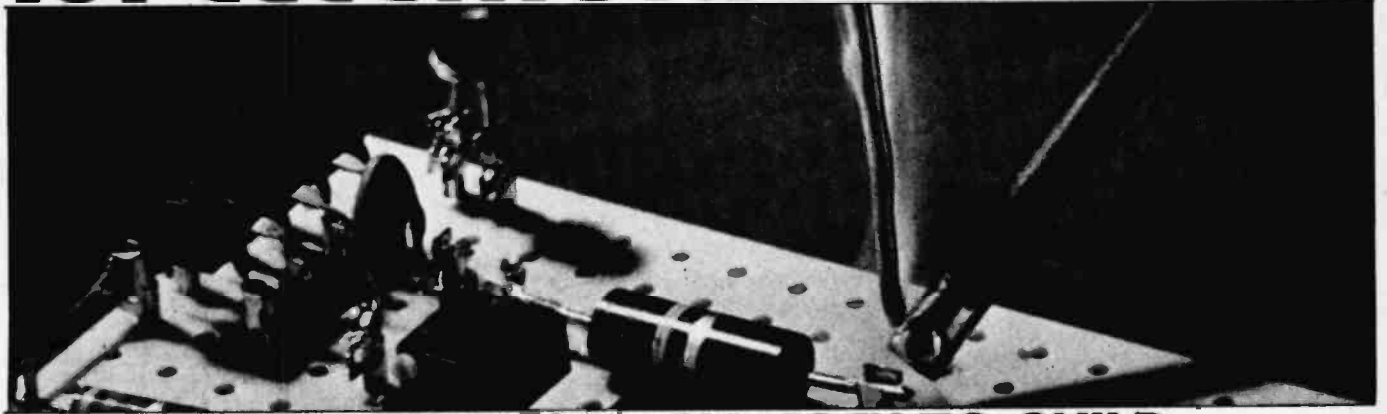

FOR UNDER \$15—ALL EASY TO BUILD

IF YOU'RE a typical experimenter you're bound to find many of the projects in this book are similar, if not identical to commercial equipment sold in electronic parts and hobby stores. And even if you're not a comparison shopper it will be evident that our projects are but a fraction of the cost of the commercial equivalent. For example, the burglar alarm control unit in this handbook costs less than \$10 in parts—less than \$6 if you're a good shopper—yet, we have seen commercial copies of this item selling for as much as \$30. And you will find that our *super sensitive field strength meter*, which can be built with parts found in almost any junk box, will cost you from \$10 to \$25 in a factory-wired version.

In short, 101 ELECTRONIC PROJECTS is a handbook of *low cost* usable circuits with everyday applications in the home, office, school, or you name it. And if anything is important, it's the term *usable*. The projects in this book aren't lifted from manufacturer's application notes, or school textbooks. Each and every project has been bench-tested to remove the bugs, and with a few exceptions each project stands alone as a complete assembly; you don't have to string a series of projects together to get a working device. Where we do provide only a working circuit intended to be part of a larger project it's because the circuit cannot be normally used alone. For example, the integrated circuit remote control amplifier usually is employed after a preamplifier provided by the builder.

In all instances we have not only put considerable effort into making certain a project will work, we have often redesigned to insure it can be built with parts readily available at your local electronic parts distributor, or through

national mail order stores. In particular, we have almost entirely eliminated "industrial" components, those hard-to-find items that seem to be sold only by industrial supply houses with minimum billing of \$25 or more. Where we could avoid designing around an industrial type component we have used a type or model normally available at low prices from surplus dealers. For example, though the 40468 field effect transistor is not the sort of component you're likely to find in your local electronic parts store, it is commonly sold for well under \$1 through industrial surplus dealers—those parts stores that generally advertise in the back pages of electronic hobby magazines such as ELEMENTARY ELECTRONICS. And if they don't stock the 40468 the month you're ready to build they would probably have a suitable substitute, such as the 40473.

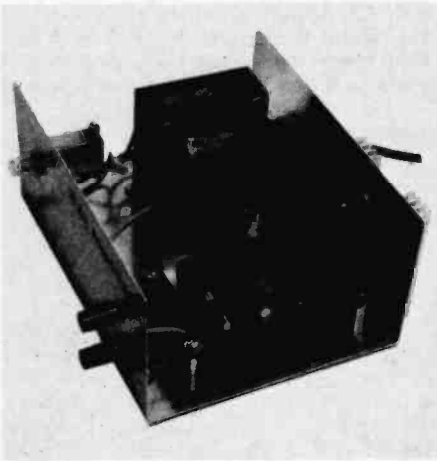

Don't let those old projects collect dust. Even ignoring the small resistors and capacitors and salvaging only the bigger, more expensive hardware such as the heat sinks, transformer, switch, electrolytic capacitor and binding posts can be like adding dollars to your construction budget.

But it's this industrial-type exception that proves the rule: most projects use components readily available in local stores. Even when we call for a special component such as a 40502 TRIAC you'll find substitutes in the RCA, Motorola, G-C, Radio Shack and Lafayette Radio blister-packaged *replacement* lines.

If the project calls for an unusual coil form not available in your area simply look up your local J. W. Miller coil distributor; you'll probably find a direct substitute in the Miller cross-index of coils, coil forms and RF transformers.

Don't Gold Plate. It's important to keep in mind that the projects in this issue were designed to be built with the least expensive components. Unless specified otherwise in the parts list use the lowest grade components available. Don't purchase the most expensive industrial or military quality parts thinking the project will work better because the parts are higher quality. The project won't work one iota better; all you will do is run up unnecessary expense. If the parts list specifies a ceramic capacitor don't use a silver mica because it's more expensive. If a silver mica capacitor is needed the parts list will specify "silver mica." Similarly, don't use 5 percent tolerance resistors when the parts list calls for 10 percent unless you can get 5 percent resistors for less money than the 10 percent variety.

As a general rule most projects in this book should cost less than \$15 in parts exclusive of the cabinet. But if you start using high performance or high tolerance components where they're not needed you can easily run the cost of a project from \$15 to \$50 or more, and still not get better performance. While we don't want to belabor the point, we do want to insure

you get maximum enjoyment for the least cost, and that is only done by building the projects the way we say to build them.

Almost all the projects are non-critical as to layout, wiring and final assembly. You can generally use any cabinet from a coffee can to a standard metal enclosure, or no enclosure at all. Most projects will even work if built on a slab of wood—the proverbial “bread-board.” Where the layout, wiring, or enclosure might affect performance we so indicate and make specific recommendations as to the type of cabinet, layout, etc. For safety’s sake, any connection carrying 24 volts or more should be taped so you cannot make accidental contact. Even the small *tingle* you might get from only 24 volts can be enough to cause you to pull away quickly, possibly causing you to come in contact with a higher voltage. So play it safe! Consider 24 VDC and higher potentially *dangerous*.

When we make no recommendations as to heat sinking of transistors and ICs none is needed, even if a power transistor is used in the project. But where we specifically call for a heat sink make certain you use one, otherwise the solid state device will be quickly destroyed by excessive heat.

Some of the voltage and current ratings given in the parts lists might appear excessive, such as a 10-VDC capacitor in a circuit with a maximum power supply of 5 VDC. We have allowed an extra margin of safety in certain projects to protect against “disasters” caused by wiring errors and/or defective components. In general, however, unusual ratings are used to keep costs down. For example, in many parts stores a 10 VDC electrolytic capacitor is less expensive than a 3- or 5-volt model, so we have specified the

less expensive 10-volt type. Similarly, ½-watt resistors are usually less expensive than the ¼- or ⅛-watt units, so we specify ½ watt for most projects even though you can probably build the project in a smaller cabinet by using the miniature resistors.

If you decide to substitute for the specified component(s) make certain the device can handle the circuit voltage, and has the same general ratings as the specified component. While you can always use higher ratings, with rare exception you can never go lower. For example, if the project calls for a rectifier rated 50 PIV at 0.5A you can safely substitute one rated 100 PIV at 1A, but you should not substitute a rectifier rated 25 PIV. Similarly, if we call for a 10-volt capacitor in a circuit with a 9-volt power supply don’t substitute a 5-volt capacitor. Unless you are certain we have overrated the component to use a common, low cost type, use our values as the minimum acceptable.

Silicon controlled rectifiers and TRIACs are the exception to the rule that you can generally overrate on the high side because their gate sensitivity often depends on the PIV rating. Always try to use the exact unit specified or its direct replacement.

Resistor and capacitor values should be exactly as specified; don’t substitute a 930-ohm resistor if 1000 ohms is called for in the parts list. If necessary, use several resistors in series or parallel to attain the specified value(s). Similarly, don’t use a 50-pF capacitor if the parts list calls for 68 pF. The one thing you *can* do is use a better tolerance than specified. For example, if the project calls for 10 percent tolerance resistors and you have a stock of 5- or 1-percent resistors you’d like to use up by all means do so. If it doesn’t cost extra you can substitute a more precise

tolerance. But remember, the project won’t work any better for it.

Straight Curves. To make assembly as goof-proof as is possible we use two types of capacitor symbols in the sche-

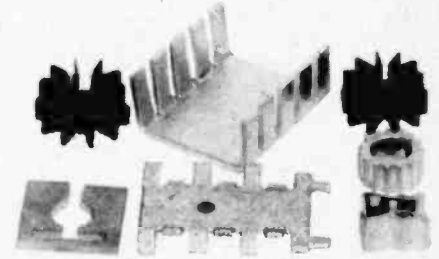

The next time you spot a buy on heat sinks at your friendly surplus dealer’s emporium take advantage and stock up on a variety of sizes and types. Sooner or later you’ll find a use for them all.

matics. The symbol with straight and curved lines with a “+” over the straight lines means an *electrolytic capacitor* that must be wired with the correct polarity. The curved line is a warning the polarity should be double-checked before the capacitor is soldered into the circuit as the project probably won’t work if the polarity is reversed.

Capacitors which are indicated with two *straight lines* are non-polarized and can be installed without regard to polarity or any markings. If the capacitor has a line on one end indicating the *outside foil* it’s a good idea to connect this end to ground when building radio frequency projects. The extra shielding of the outside foil might make some difference in stability when using old style “paper” capacitors.

Unless specified otherwise—such as *audio* or *linear taper*—potentiometers can have any taper; use whatever you can get at lowest cost.

When battery types are suggested do not substitute a battery with less current handling capacity. The current requirements for battery powered projects has been taken into account when choosing the battery and a battery with the minimum acceptable capacity has been specified. Keep in mind you can always substitute a battery type with a higher current capacity if you want longer operation between battery replacements.

Easy On The Changes. Because of normal variations in the gain of solid-state devices it might be necessary to “tweak” some values to get minimum distortion from an amplifier at high

If you take your time, check for wiring mistakes and cold solder joints, chances are that your project will work for you the first time you switch the power on.



levels, or to get an RF oscillator to "start." You can try changing the value of a transistor's bias resistor, but stay within ± 20 percent of the specified value.

Sudden Death. While most transistors can take considerable overload and then bounce back to do the job, you rarely get a second chance with integrated circuits. Use the wrong voltage, make an incorrect connection, and the IC gets *zapped*. Before applying power to an IC project take extra time to carefully check every connection. Make certain there are no solder-bridge shorts if you used a printed circuit board. Double-check that all electrolytic capacitor polarities are correct. Finally, make certain you have the correct power supply voltage before connecting the power supply wires to the IC. You get only one chance with an IC, so make certain you have everything correct the first time.

Voltage Variations. As a general rule ordinary transistor circuits shown in this book can operate successfully over a broad voltage range because most of



One solution to the parts problem is to use kits such as this one from Radio Shack. And with the pegboard construction it's easy to tear it down later, adding the components to your junkbox.

them have been designed for battery operation, and allowance has been made for reduced battery voltage as the battery is used, or ages. For example, a project calling for a 9-VDC power supply will probably work just as well with 7 volts, often just as well with six or five volts. Similarly, a few extra volts won't affect most transistor projects as long as the voltage ratings of the capacitors in the project aren't exceeded. If a project calls for 6 VDC and you have a 7.2- or 8-volt battery eliminator power pack by all means give it a try.

But when it comes to ICs you've got to be a little more careful. As long as you're within a volt or two of the specified value the project will work without problems, but when in doubt try to stay under the specified voltage. If the project calls for ± 12 VDC and your power supply delivers even as low as ± 9 volts

WHERE TO BUY COMPONENTS

Active Electronic Sales Corp.
P.O. Box 1035

Framingham, MA 01701

ADVA Electronics

Box 4181
Woodside, CA 94062

Allied Electronics Corporation

P.O. Box 1544
Fort Worth, TX 76101

Amidon Associates

12033 Otsego Street
North Hollywood, CA 91607

Barry Electronics

512 Broadway
New York, N.Y. 10012

B&F Enterprises

119 Foster Street
Peabody, MA 01960

Bullet Electronics

P.O. Box 19442
Dallas, TX 75219

Burstein-Applebee

3199 Mercier Street
Kansas City, MO 64111

Circuit Board Specialists

3011 Norwich Avenue
Pueblo, CO 81008

Circuit Specialists Company

P.O. Box 3047
Scottsdale, AZ 85257

Edmund Scientific Company

300 Edscorp Building

Barrington, NJ 08007

Fair Radio Sales

Box 1105

Lima, OH 45802

Bill Godbout Electronics

Box 2355

Oakland Airport, CA 94614

James.

1021 Howard Avenue
San Carlos, CA 94070

Lafayette Radio Electronics

111 Jericho Turnpike
Syosset, NY 11791

Meshna

P.O. Box 62
East Lynn, MA 01904

MHz Electronics

2543 North 32nd Street
Phoenix, AZ 85008

J.W. Miller Division

Bell Industries
Box 5825

Compton, CA 90224

Optoelectronics, Inc.

Box 219
Hollywood, FL 33022

Poly Paks

Box 942
Lynnfield, MA 01940

G.R. Whitehouse & Co.

Newbury Drive
Amherst, NH 03031

go ahead and give it a try. But if your supply is ± 15 VDC try to back it down near 12 volts.

Be careful of TTL logic circuits. They require a *regulated* power supply of 5 volts (5.5 volts absolute maximum). If your TTL supply comes out 4.5 volts that's okay. It's 5.5 volts that's the safety limit. As a general rule, always use a regulated power supply for TTL. Either build one into the project using one of the popular three-terminal regulators or use an external homebrew or commercial regulated supply.

Use Sockets. Solid-state devices are not 100 percent reliable when obtained from hobby and technician supply sources. Transistors and ICs do fail, and while it's possible to remove a two-terminal diode or three-terminal transistor from a printed circuit board it's really no great loss if the part is destroyed in the process as few discreet hobby-grade components cost more than \$1. But ICs are a whole different ball of wax. Not only are some ICs relatively expensive (though some sell for as low as 15 cents), but they have upwards of eight leads; generally 14, 16 or more leads. By the time you get

them unsoldered there's a good possibility you've ruined the printed circuit board and possibly a handful of other components—now the damage is not only expensive but time-consuming.

In the long run you save time and money by using sockets for ICs. Best of all, you can easily troubleshoot the project by substituting a different IC if you suspect the original is defective.

Save, Save, Save. As we said before, we have tried to use the lowest cost components in our projects; after that it's up to you. You can either pay full list for components or take advantage of quantity discounts. For example, one of the local chains sells two resistors for 25 cents. Another store gets 35 cents for the same package. And yet another store will sell you one of the resistors for 25 cents. Figure you can blow several dollars just on the resistors needed for a project. But if you purchase one of those 100-for-\$1, or 100-for-\$2 resistor assortments you'll probably end up with the resistors you need and a lot left over for other projects. Same thing with electrolytic capacitors. Under some brand names they cost

(Continued on page 77)

101 ELECTRONIC PROJECTS

FOR UNDER \$15

1 SWL's Super Signal Booster

□ Super sensitivity is the feature of this two-transistor shortwave pre-selector. It provides overall gain as high as 40 dB from 3.5-30 MHz.

Diode D1 protects against excess gate voltage caused by nearby transmitters, while Q1 serves as an emitter follower to match the medium output impedance of the FET transistor to the low input impedance of the receiver.

Since Q1 is a MOSFET type with a gate that's very sensitive to static changes, Q1 must be handled with a short-circuit across all leads until just before power is applied. Also, a soldering iron must not be applied to Q1's leads unless they are shorted.

L1's connections are specified in the instructions supplied with the coil. A short length of RG-174U coaxial cable should serve as the connection between the preselector output and the receiver with which the unit is to be used.

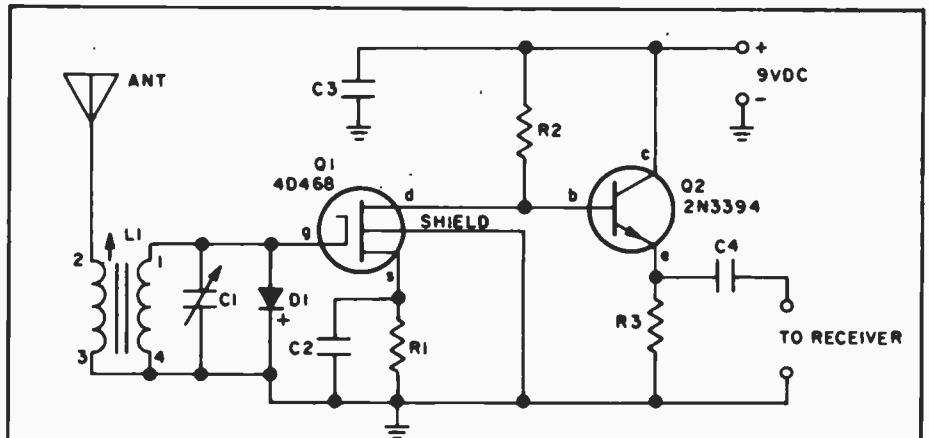

PARTS LIST FOR SWL'S SUPER SIGNAL BOOSTER

C1—365-pF tuning capacitor
 C2, C3—0.05-uF, 25-VDC capacitor
 C4—470-pF, 25-VDC capacitor
 D1—1N914 diode
 L1—Antenna coil: 1.7-5.5 KHz use Miller B-5495A, 5.5-15 MHz use

Miller C-5495A, 12-36 MHz use Miller D-5495-A
 Q1—RCA 40468 FET transistor (Do not substitute)
 Q2—2N3394 npn transistor
 R1—470-ohm, ½-watt resistor
 R2—2400-ohm, ½-watt resistor
 R3—4700-ohm, ½-watt resistor

2 Wireless BC Booster

□ Just about any standard radio can be turned into a DX hound with this easy-to-build wireless broadcast band booster. Transistor Q1 in conjunction with antenna coil T1 provides from

10 to 20 dB extra gain to snare those weak BC stations. The project should be assembled in a metal cabinet as "feedback" from coupling coil L1 to the input will cause oscillation.

Field effect transistor, (FET) Q1 is the type with built-in diode protection so you don't have to worry about strong signals or static discharges. To use the booster, first set C1 to

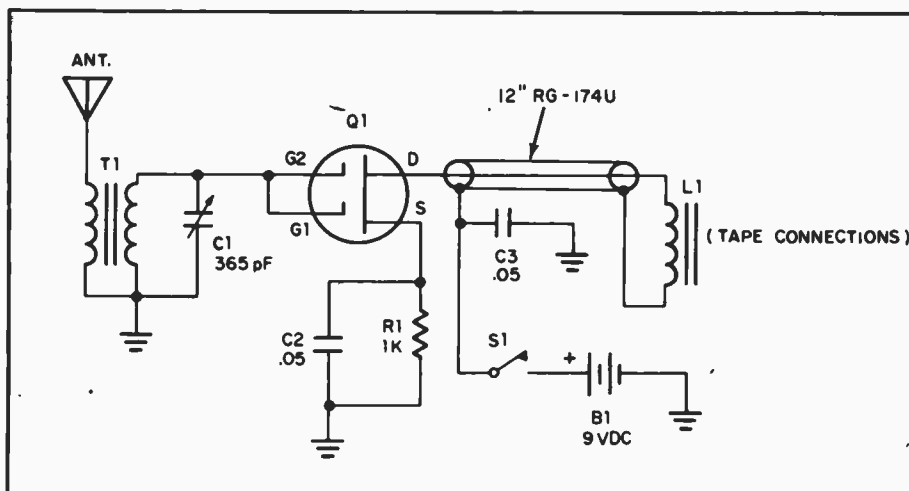

PARTS LIST FOR WIRELESS BC BOOSTER

B1—9-volt transistor battery
 C1—365-pF tuning capacitor (Radio Shack 272-1341 or equiv.)
 C2, C3—0.05-uF disc capacitor
 L1—Loopstick coil (Radio Shack 270-1430)
 Q1—FET, RCA 40822, 3N187, or equiv.
 R1—1000-ohms, ½-watt resistor
 S1—Spst slide or toggle switch
 T1—J. W. Miller A-5495A antenna coil
 Misc.—Co-axial cable, cabinet

the approximate frequency of the desired station—C1 is supplied with a calibrated dial. Place coil L1 parallel to the rod antenna inside the radio. L1 can be taped to the back of the radio. Turn the radio on and tune in

the desired station; then peak the signal with C1. C1 can also be used to reject excessively strong signals which might be interfering with the desired station. You cannot, however, reject a station close to, or on the same

frequency as the desired station.

The antenna can be any length of wire from 3 feet or longer. If you use a metal cabinet connect the antenna into the circuit through an insulated binding post.

3 Communications Rebroadcaster

□ One way to keep an ear on the Amateur or Citizens band while working around the house or searing steaks out on the patio, is to install a lot of remote speakers. An easier way is to feed the audio signal from your CB or amateur receiver into a broadcast band Rebroadcaster and radiate the signals throughout the house and yard. A small transistor pocket radio tuned to the rebroadcaster frequency will alert you instantly if a call is received on your communications gear. Best of all, since the radio travels with you, you're never away from your receiver.

Build the rebroadcaster in a metal cabinet. The power supply can be a transistor radio type 9-volt battery, though a line supply is preferred for more dependable continuous operation. The unit draws about 10 mA. Power input and antenna length are limited by FCC regulations. If the in-

PARTS LIST FOR COMMUNICATIONS REBROADCASTER

C1, C4—0.05- μ F disc capacitor, 50 VDC or better.

C2—47-pF silver mica capacitor, 100 VDC or better, Allied Electronics 782-0860

C3, C5—0.01- μ F disc capacitor, 50 VDC or better

L1—Oscillator coil, Miller 2022 (Do not substitute)

Q1—NPN transistor, HEP-720

R1—6200-ohm, 1/2-watt resistor, see text

T1—Output transformer, 4 ohms to 1000 or 2500 ohms

put current exceeds 10 mA, increase the value of R1 in 20% increments until the current is below 10 mA. The antenna wire cannot exceed 10 feet. Adjust slug L1 so the rebroadcaster operates on an unused BC

frequency. The audio input connects to the speaker or headphone output of your communications equipment. Adjust the volume on the receiver for a high, undistorted transmission by the rebroadcaster.

4 No Parts BC Booster

Just about any transistor radio can be made a "DX hound" with the No-Parts BC Booster. Simply bring in the end of an outdoor "longwire" antenna and wrap the end around the radio about 5 times.

Even better reception is possible if

you open the radio and wrap about 5 turns around the rod antenna immediately adjacent to the antenna coil mounted on the rod. Make certain the ends of the antenna are insulated with glass or ceramic insulators.

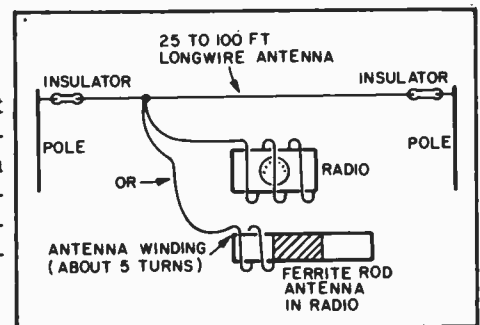

5 Earphone Limiter for CW

□ Most receivers don't provide automatic volume control on code reception. Thus a CW signal that blows your headphones off one moment might lie buried on the threshold of hearing the next. The Headphone Limiter chops those S9-100 signals

PARTS LIST FOR EARPHONE LIMITER FOR CW

D1, D2—1N60 diode

R1—5000-ohm audio taper potentiometer

Rx—See text

down to size until they equalize with weaker signals, giving relatively constant headphone volume. Because the clipping action produces some distortion,

the limiter should feed a headphone Q-peaker (described in another circuit).

The value of Rx should match the

existing speaker impedance and power. In most cases this will be equal to 4 ohms at 2-5 watts.

6 SWL's Simple Squelch

It's almost a universal rule that two-way radios have a squelch control, a device that mutes the background noise until a station is received. Even public service radios now include a squelch, so why put up with ear-jarring noise when listening on your SWL receiver. Just a couple of #47 pilot lamps scrounged from old tube radios and two resistors are all that's needed to squelch your SW receiver. And if you can't scrounge the lamps, they're available at just about every radio parts distributor and service shop. Switch S1 is needed only to bypass the squelch for very

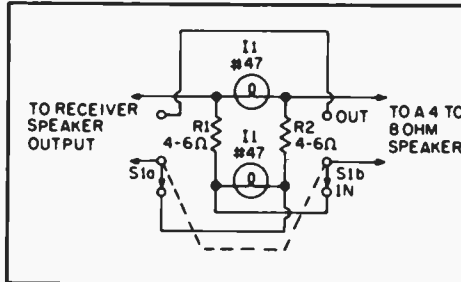

PARTS LIST FOR SWL'S SIMPLE SQUELCH

- I1, I2—#47 pilot lamp
- R1, R2—4 to 6-ohm resistor, 1-watt, 10 percent
- S1—Dpdt switch

weak signals.

In many instances, the circuit will provide a basic attenuation of the noise background, not complete squelch. But it's a substantial squelch

considering the low cost and ease of construction. Just about any enclosure, plastic or metal, can be used. The components can even lie on the table.

7 Hi Z Earphone Booster

Quite often the audio output from small projects is just barely sufficient to produce a recognizable signal in standard experimenter magnetic earphones. Yet a handful of surplus components will provide enough gain to turn that whisper sound into a roar.

Specifically intended for use with magnetic earphones of from 1000 to 5000 ohms impedance, the Earphone Booster can do double-duty as an audio signal tracer. Transistor Q1 can be any PNP of the 2N2613 variety. Even the 10-for-a-buck kind will work. Volume control R1 should have an audio taper. Distortion control R3 can have any taper. Make certain

C2's polarity is correct; the positive terminal connects to volume control R1 (wiper terminal). Adjust distortion control R3 for best sound quality. If you use a jack and plug to connect your earphones to this amp, you can eliminate on-off switch S1 because

power is removed whenever the headphones are disconnected.

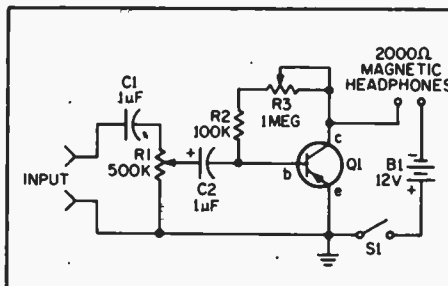

PARTS LIST FOR HI Z EARPHONE BOOSTER

- B1—Battery, 12 volts (two RCA VSO68 in series or equiv.)
- C1—0.1-uF capacitor, 15 VDC or better
- C2—1-uF electrolytic capacitor, 15 VDC or better
- Q1—PNP transistor, 2N2613 or equiv. (Radio Shack 276-2003)
- R1—500,000-ohm audio taper potentiometer
- R2—100,000-ohm, 1/2-watt resistor
- R3—1-Megohm potentiometer, any taper

8 Crystal-Transistor Radio

That old favorite, the crystal radio, becomes more than just a weak voice buried in the headphone when it's amplified with a "junk box" amplifier.

Transistor Q1 can be just about any general purpose pnp germanium type such as the 2N107, 2N109, etc. The SK3003 specified gives a little

extra gain.

L1 is any ferrite antenna coil for the broadcast band, while E1 must be a magnetic headset for maximum output level. To align the receiver, set C1's dial to the known frequency of a strong local station and adjust L1's slug until you hear the station in the phones.

For reception of weaker signals the receiver should be connected to an earth ground such as the cold water pipe. The longer the antenna, the better the reception. Try 20 feet or more.

To feed the radio's output into an amplifier and speaker, replace the headphone with a 1000-ohm, 1/2-watt

resistor. Connect a .1 mfd, 25VDC capacitor from Q1's collector to the amplifier input. Then be sure to connect radio's ground to the amplifier ground.

- PARTS LIST FOR CRYSTAL-TRANSISTOR RADIO**
B1—9-V battery
C1—365-pF tuning capacitor

- C2**—0.2-uF, 10-VDC capacitor
D1—1N60 diode
E1—Hi-impedance magnetic earphone (Calectro J4-825)
L1—Ferrite antenna coil (Radio Shack 270-1430)
Q1—SQ3003 (RCA)
R1—100,000-ohm, ½-watt resistor

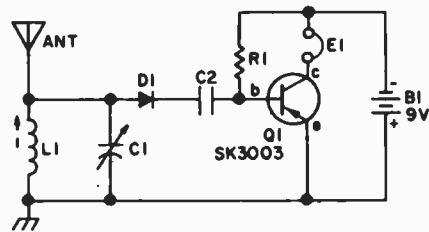

9 Self-Powered CW Monitor

PARTS LIST FOR SELF-POWERED CW MONITOR
C1—0.05-uF disc capacitor, 50 VDC or better
L1—2 to 6 turns on ½-in. form, see text
Q1—PNP transistor, HEP-253 (Radio Shack 276-2004)
R1—8200-ohm, ½-watt resistor
T1—Miniature transistor transformer, 500 ohms center tapped to 500 ohms, Lafayette Radio Electronics 33 R 85531 (do not use secondary CT)

Here's a self-powered CW keying monitor that doesn't require a direct connection to the transmitter or transmission line. Position coil L1 near the transmitter output tank until you obtain a dependable key-down

tone. Then tape the coil in position. While the signal is generally monitored with headphones, a small monitor amplifier can be used. Simply connect a 2000-ohm, ½-watt resistor in place of the phones, and connect the amplifier input across the resistor. Start with a 2-turn coil made of #16 enameled wire wound on a ½-inch form.

If the signal pickup is not sufficient to produce a steady tone, increase the coil one turn at a time until the tone is steady and reliable. If you cannot obtain any sort of tone with any coil, reverse the primary connections A and B.

10 29¢ Mag. Phone Filter

If you're tired of copying CW signals through the grind without a Q-multiplier on your receiver, the 29¢ Mag. Phone Filter is the next best answer. It's the cheapest route to greater selectivity.

Capacitor C1 plus the inductance of a magnetic headset form a parallel resonant circuit at approximately 1 kHz. All other signals are sharply attenuated so you hear mainly the signal you want. Resistor R1 isolates the resonant circuit to prevent a re-

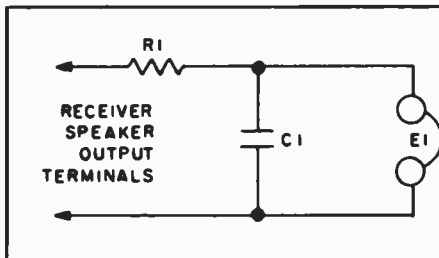

- PARTS LIST FOR 29¢ MAG. PHONE FILTER**
C1—0.005-.05-uF capacitor (see text)
E1—2000-ohm magnetic headset
R1—100,00-ohm, ½-watt resistor

ceiver's low output impedance from reducing the "Q" of the headset circuit.

The exact value of C1 depends on

the particular headset. Try different values in the range shown until the desired resonant frequency or peaking action is obtained.

11 Pep Up a Pocket BCB

Here's a low cost project that can pack a lot of extra sensitivity into an ordinary transistor pocket radio. You'll be able to do some extensive broadcast band DXing with that pocket portable the bank gave you when you opened an account.

Assemble the unit in a small plastic cabinet with coil L cemented to the side or back of the cabinet; use an adhesive such as General Electric's RTV. Connect from 10 to 80 feet of antenna wire to the input, and position this pocket booster flat against

the radio with L1 directly behind the loopstick antenna built into the radio. Tune capacitor C2 to the approximate frequency you want to receive, then turn on the radio and listen to the signals boom in. Keep in mind that the receiver's normal AVC ac-

tion will mask any boost applied to strong signals.

PARTS LIST FOR PEP UP A POCKET BCB

- B1**—1.5-volt penlight AA battery
C1—0.005- μ F disc capacitor, 25 VDC or better

- C2**—365-pF miniature tuning capacitor with dial
C3—0.05- μ F disc capacitor, 25 VDC or better
L1—Loopstick for C2 (Radio Shack 270-1430)
Q1—NPN transistor, HEP-641 (Radio Shack 276-2002)
R1—39,000-ohm, $\frac{1}{2}$ -watt resistor
S1—Spst switch (on-off)

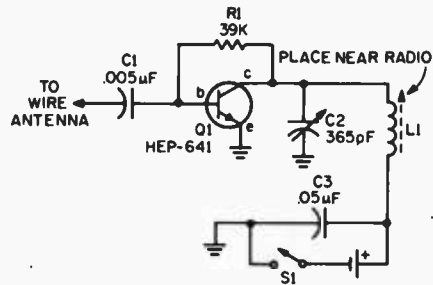

12 CB/AM Coupler

□ If you're tired of having your friendly new car dealer knock \$100 or so off the trade-in allowance because you drill holes in the body for CB antennas, simply replace the existing auto radio antenna with a cowl-mounted CB whip, install the CB coupler and no one will know you ever had a CB whip on the car.

Cowl-mounted CB whips generally are exact replacements for auto antennas. The coupler automatically connects the antenna to either the car radio or CB rig. When transmitting on CB the series tuned circuit of C1-L1 passes the RF along to the antenna, while R1 blocks the RF from

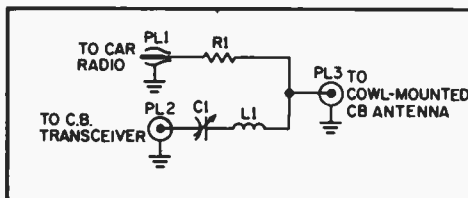

GET BC FROM A CB ANTENNA

- C1**—4-40-pF trimmer capacitor
L1—RF choke, Ohmite Z-144 or equiv.
R1—560-ohm, $\frac{1}{2}$ -watt resistor

feeding through to the car radio. When receiving broadcast stations C1-L1 represents a high impedance, thereby blocking the signals from entering the CB rig where they would short-out. Instead, the broadcast signals pass through R1 to the car radio.

Build the coupler in a small metal

enclosure. Plugs PL1, PL2 and PL3 should match the existing jacks on the radio equipment, usually PL-259 for the CB set and a Motorola-type for the AM or AM/FM auto radio. To adjust C1, connect an SWR meter between PL2 and the transceiver and adjust C1 for minimum SWR.

13 Scope Your CB Signal

□ Critical inspection of a transmitter signal and accurate measurement of modulation is possible only with an oscilloscope. Note that you must use your scope's vertical *plate* connection. The RF signal can't travel through the vertical amplifier unless your scope happens to cost a kilobuck or more. Unfortunately, a CB transmitter's RF output is so low the scope pattern is barely discernible—unless

you use this booster.

Since a scope's vertical plate connections operate at a high input voltage, it requires that a CB transmitter's output be fed to a resonant circuit to step up to high RF voltage. The circuit shown will just about fill a 5-in. scope from edge to edge with virtually no loss at the transmitter.

First, wind L2 on the center of a $\frac{3}{8}$ -in. slug-tuned coil form

L1 adjacent to the ground end of L2. Connect L1 across the transmitter output with the CB antenna system also connected.

Adjust L1's slug for minimum standing-wave ratio (SWR). If the coil is correctly made, there should be no change in the antenna system's SWR. Adjust C3 for the desired scope trace height; it may be necessary to reset L1 each time C3 is adjusted.

PARTS LIST FOR SCOPE YOUR CB SIGNAL

- C1, C2**—5-pF silver mica capacitor
C3—60-pF trimmer capacitor
L1—3 turns #22 solid, plastic-insulated wire, adjacent to ground end of L2
L2—4 turns #18 enameled wire, centered on form
1— $\frac{3}{8}$ -in. RF slug-tuned coil form (J. W. Miller 4400-2)

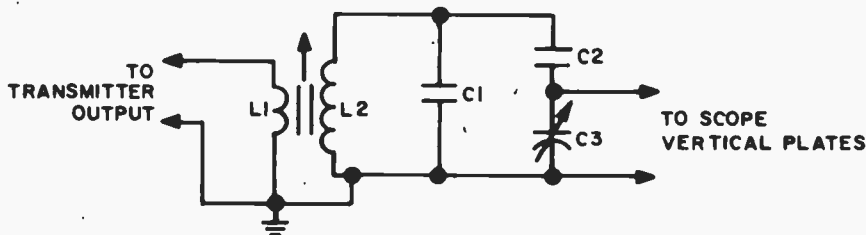

14 CB Pager

□ Small enough to fit into a cigarette pack, this pocket-sized paging transmitter produces a low-output signal

on the Citizens Band (27 MHz) suitable for paging inside a building. The signal is strong enough to be heard

on a standard CB transceiver, but not enough to cause receiver overload.

If only one crystal frequency is needed, socket SO1 can be eliminated and an over-tone type crystal soldered directly into the circuit. Salvage crystals from junked units. The whip antenna is a standard walkie-talkie three-section replacement type. The carbon microphone can be a telephone transmitter.

To tune, receive the signal on an S-meter-equipped receiver and adjust trimmer C3 for maximum output. Key the transmitter a few times to check crystal activity. If starting is intermittent, slightly alter C3's adjustment until operation is consistent.

The power supply can be a standard 9V (2U6) battery.

PARTS LIST FOR CB PAGER

- C1, C2—0.001- μ F, 50-VDC disc capacitor
- C3—60-pF trimmer capacitor
- L1—10 turns #16 enameled wire wound on $\frac{3}{8}$ -in. form, spaced 1 in. end to end
- MIC—Carbon microphone element
- Q1—HEP-50 npn transistor
- R1—47,000-ohm, $\frac{1}{2}$ -watt resistor
- R2—10,000-ohm, $\frac{1}{2}$ -watt resistor
- R3—330-ohm, $\frac{1}{2}$ -watt resistor
- SO1—Crystal socket

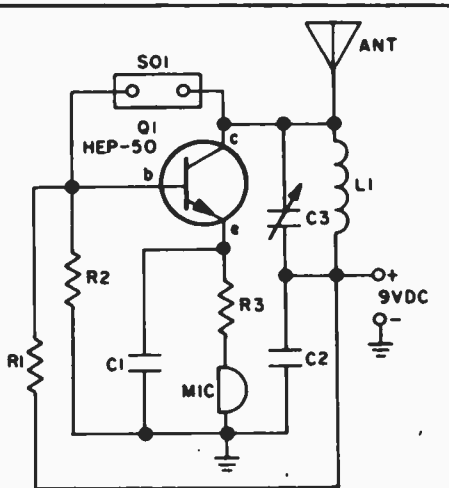

15 CB Modulation Lamp

□ Less than \$2 is all that's needed to be certain that what you put into the mike is really getting to your sky hook. Working directly from a minute sample of the transceiver's RF output, the Modulamp will glow only if there is a carrier output and modulation. So if no one replies to your call and the lamp glows in step with your modulation, you can at least be certain it's not the transceiver that's at fault.

If the unit is built into a small metal box, jacks J1 and J2 should match the existing transmission line connectors. If you build the Modulamp directly into your transceiver, simply connect capacitor C1 to the RF output jack (and forget about J1 and J2). To adjust, simply talk into the mike in your normal voice and

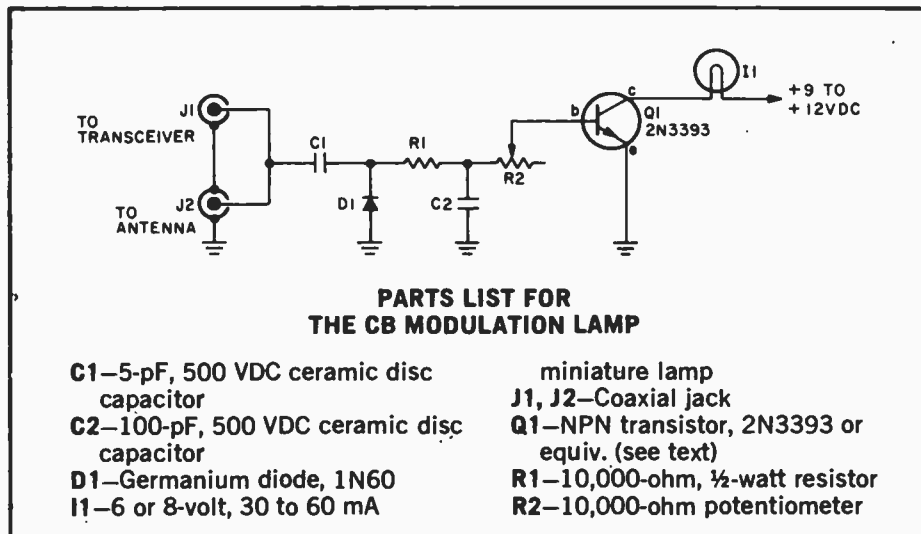

PARTS LIST FOR THE CB MODULATION LAMP

- C1—5-pF, 500 VDC ceramic disc capacitor
- C2—100-pF, 500 VDC ceramic disc capacitor
- D1—Germanium diode, 1N60
- I1—6 or 8-volt, 30 to 60 mA miniature lamp
- J1, J2—Coaxial jack
- Q1—NPN transistor, 2N3393 or equiv. (see text)
- R1—10,000-ohm, $\frac{1}{2}$ -watt resistor
- R2—10,000-ohm potentiometer

adjust trimmer potentiometer R2 until lamp I1 flashes in step with the modulation. If I1 will not flash re-

gardless of R2's adjustment, substitute a higher gain transistor for Q1 (try a 2N3392).

16 Talk Power Booster

□ If your CB or Ham rig is a little shy on talk power, this 10 dB talk power booster will give your signal that extra edge through the QRM. The input impedance is high enough

to handle anything from a low impedance dynamic mike to a crystal or ceramic model. You can run the booster into just about any rig; chances are it will work. Since it's so

easy and inexpensive to try out a breadboard model, don't bother worrying about the input impedance of your rig; it's faster to give it a try.

Potentiometer R4 serves as the

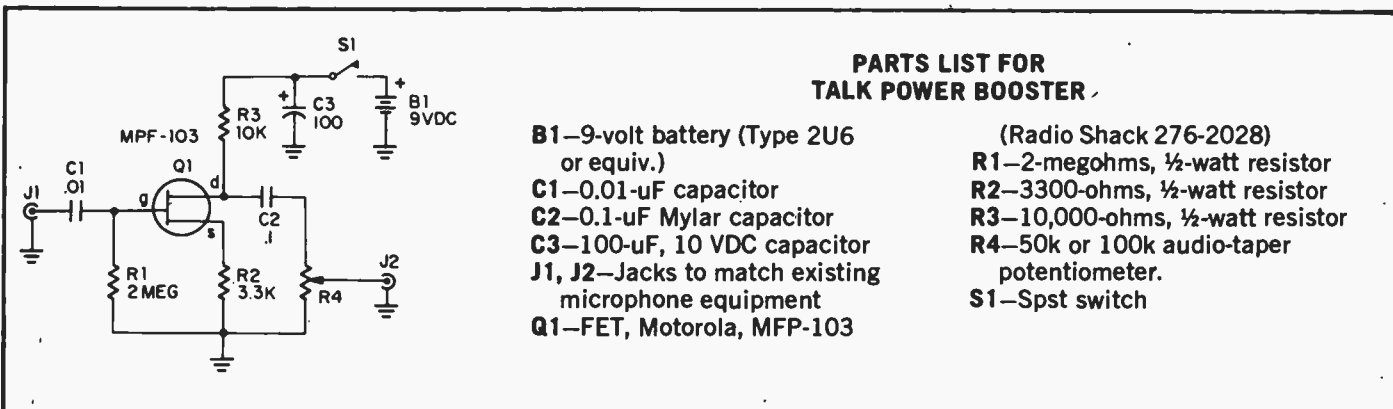

**PARTS LIST FOR
TALK POWER BOOSTER**

- B1—9-volt battery (Type 2U6 or equiv.)
- C1—0.01-uF capacitor
- C2—0.1-uF Mylar capacitor
- C3—100-uF, 10 VDC capacitor
- J1, J2—Jacks to match existing microphone equipment
- Q1—FET, Motorola, MFP-103
- R1—2-megohms, ½-watt resistor
- R2—3300-ohms, ½-watt resistor
- R3—10,000-ohms, ½-watt resistor
- R4—50k or 100k audio-taper potentiometer.
- S1—Spst switch

volume control into your rig; it is adjusted for optimum modulation, as indicated on a modulation meter or other reliable device.

Jacks J1 and J2 match your exist-

ing microphone and transmitter connectors. Battery B1 can be the type used for small transistor radios as the current drain is but a few milliamperes. Capacitor C3 must be used

regardless of what you use for a power supply. A metal cabinet is suggested to keep hum and RF out of the microphone system.

17 CB Modulation Monitor

□ You can measure CB audio modulation percentage with the accuracy of the local broadcast station—'cause you'll be using the same type system.

In building the circuit, keep R1, R2 and D1's leads as short as possible. Meter M1 must be a high-speed model, such as the Alco P-1000 series. Connect the meter across the transceiver's RF output with a coaxial T-connector in the transmission line. As you key the transmitter, set switch S1 to *calibrate* and adjust R2 for a full scale reading. Accuracy will be within 10 percent.

Better accuracy is assured if R2's adjustment and meter calibrating point is compared against a scope modulation pattern. Don't compare this meter against commercial CB modulation meters. On a tone signal, this one is less accurate, but on speech modulation, the commercial models are not as accurate as a circuit of this type.

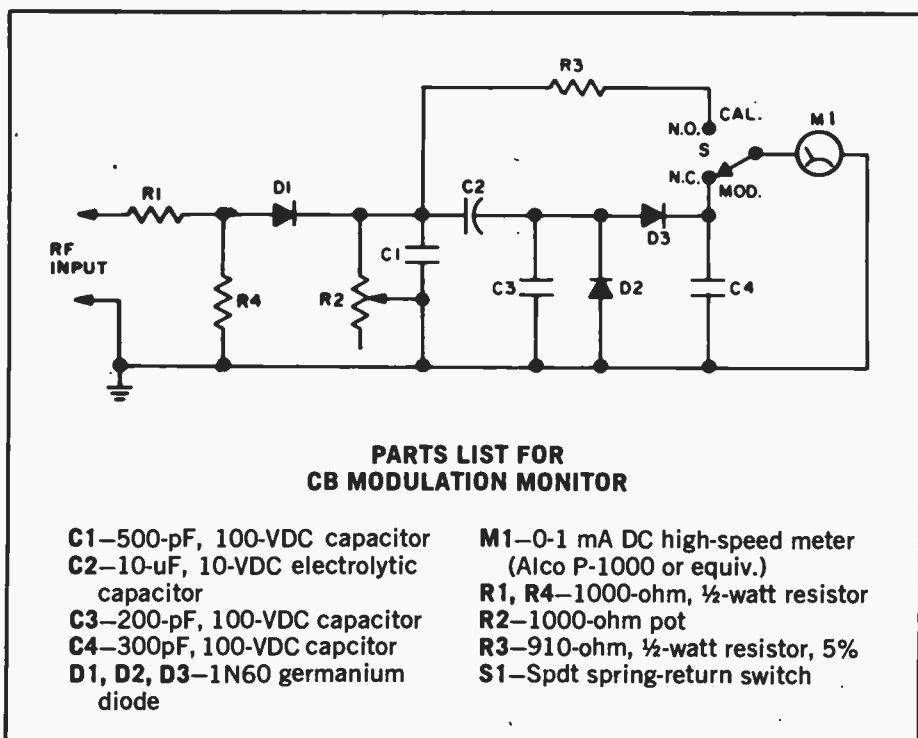

**PARTS LIST FOR
CB MODULATION MONITOR**

- C1—500-pF, 100-VDC capacitor
- C2—10-uF, 10-VDC electrolytic capacitor
- C3—200-pF, 100-VDC capacitor
- C4—300pF, 100-VDC capacitor
- D1, D2, D3—1N60 germanium diode
- M1—0-1 mA DC high-speed meter (Alco P-1000 or equiv.)
- R1, R4—1000-ohm, ½-watt resistor
- R2—1000-ohm pot
- R3—910-ohm, ½-watt resistor, 5%
- S1—Spdt spring-return switch

18 CB RF Detector For VOM/VTVM

□ Though CB field strength meters aren't too expensive, for many CBers there's often no real reason to have one, until the time comes when you need to check out your rig or antenna, and then it's too late. But if you have a VOM or VTVM and some spare parts around you can throw a CB RF detector together in a few minutes time. Fact is, you don't

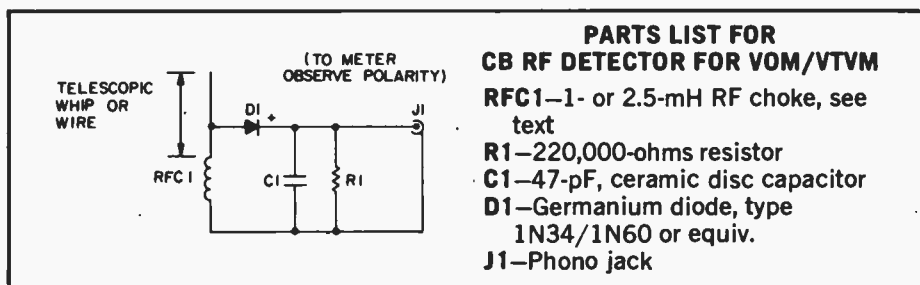

**PARTS LIST FOR
CB RF DETECTOR FOR VOM/VTVM**

- RFC1—1- or 2.5-mH RF choke, see text
- R1—220,000-ohms resistor
- C1—47-pF, ceramic disc capacitor
- D1—Germanium diode, type 1N34/1N60 or equiv.
- J1—Phono jack

even have to solder the wires, just twist them together.

While RFC1 is shown as 1-mH or 2.5-mH, those are optimum values. Just about any RF choke can be used, including any choke salvaged from an old CB transceiver. Similar-

ly, C1 can be 47-pF or any other higher value to 0.001-uF. And if R1 is anywhere near 220,000-ohms, that's okay too.

Simply connect the RF detector's output to your VOM or VTVM and select the meter range that gives a

convenient scale indication. If your meter reads reverse off-scale, just switch the test lead connections. If you build the detector as a "permanent project" a phono jack output will insure proper meter polarity every time.

19 CB Remote Volume Control

Your CB rig can do double duty by feeding signals around the house. But to avoid blasting the sound in one location while it's a pipsqueak somewhere else, connect an L pad at each speaker, then run the transceiver gain nearly wide open.

The L pad is a special impedance-matching volume control that lets you adjust the volume at each individual speaker from full off to full on, without affecting the volume at

the other speakers. Regardless of the impedance of the speakers you're

using, best results are obtained with 8 ohm L pads.

PARTS LIST FOR REMOTE VOLUME CONTROL

L1, L2—8-ohm L pad, Radio Shack 40-979 for stereo, Radio Shack 40-980 for mono
PL1—Plug to match your external speaker jack

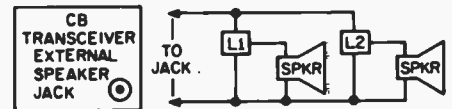

20 Low Voltage Diode Tester

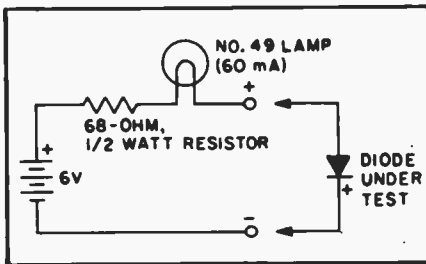

Low voltage signal diodes are easily tested with this "go/no-go" checker. The only restriction is that a diode under test be rated to handle at least 60 mA. Diodes such as the IN34 cannot be checked since test current is too high.

If the diode is good, the lamp will light in one direction, and remain

dark when the diode is reversed. If the lamp stays on when the diode is reversed, the diode is shorted. If the lamp stays dark when the diode is reversed, the diode is open.

To test diodes rated under 60 mA, a lower current lamp must be substituted in the checker.

21 Fire Up a Nixie

Using *Nixie* tubes you can transmit numerical signals or even ball scores over long distances.

The Nixie—actually a peanut-size tube—has 10 numerical-shaped neon lamps (0 through 9). By shorting the appropriate lead to ground, an internal neon lamp corresponding to that number is illuminated.

Transformer T1 is 250V center-tapped, providing an output voltage (peak DC) of approximately 200. Though current requirements are very low, D1 and D2 should be line-voltage type silicon rectifiers of 200 mA minimum.

The same power supply can be used for additional *Nixies*, each con-

necting to the top of C1. The neon numbers can be turned on either through an 11-position (one position for off) rotary switch or individual toggle switches.

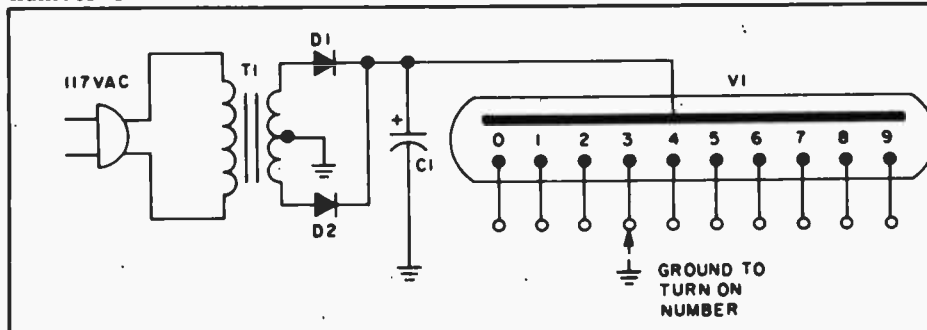

PARTS LIST FOR FIRE UP A NIXIE

C1—40-uF, 250-VDC electrolytic capacitor
D1, D2—1A, 400-PIV silicon rectifier
T1—117-V primary, 250-V secondary, 25-mA center-tapped power transformer
V1—Neon readout tube (National Electronics NL840 or any high voltage "Nixie" gas discharge-type tube)

22 Versatile Tone Oscillator

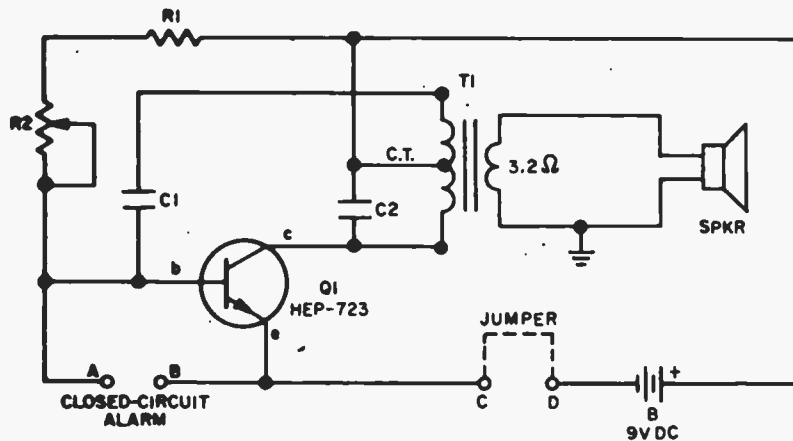

PARTS LIST FOR VERSATILE TONE OSCILLATOR

- B1—9-V battery
- C1, C2—0.02- μ F, 25-VDC capacitor
- Q1—npn transistor, HEP-723
(Do not substitute)
- R1—10,000-ohm, $\frac{1}{2}$ -watt resistor
- R2—500,000-ohm pot
(Calectro B1-666)
- Spkr—3.2-ohm speaker
- T1—Output transformer:
5000-ohm center-tapped
primary to 3.2-ohm secondary.

□ The circuit is a Hartley oscillator whose tone is determined by R2's value. Just about any wiring or layout will work, but transformer T1 must be the type used in table radios. A miniature transistor transformer might not oscillate, or if it does, will produce only "clean" high tones, with no raucous or low frequency tones.

For CPO operation connect a hand

key across points C and D. For a "make" intruder alarm, connect one or more normally open magnetic switches across points C and D. For a "break" intruder alarm connect a jumper across C and D and connect a series wire circuit across A and B, which disables the oscillator though power is applied. An intruder breaking the series circuit, or a normally

closed magnetic switch, causes the alarm to sound off.

For use as a signal generator, connect C and D and attach a shielded test signal lead directly across the speaker terminals.

Service Note: If the unit fails to oscillate, generally due to transistor differences, change C2's value slightly.

23 Audio Powermeter

□ Here's an easy way to measure an amplifier's output power without trying to convert voltage to power measurements. Resistor R1 provides the load for your amplifier and should be rated at least twice the maximum amplifier power output; for example, if your amp puts out 25 watts, R1 should be rated at least 50 watts.

The meter scale must be hand calibrated, and will take some time and effort, but once done it's done for good. Remove the scale cover from meter M1 and borrow an AC variable autotransformer, or connect a 1000 Hz signal generator to the amplifier output. Connect the output of the autotransformer (or amplifier) to binding posts BP1 and BP2, and connect an AC voltmeter (VOM) across the binding posts. Set R2 to off—full counter-clockwise if correctly wired. Adjust the autotransformer (or amplifier) output until the AC meter indicates 20 V rms—the voltage for 50 watts across 8 ohms.

Adjust potentiometer R2 for a full

PARTS LIST FOR AUDIO POWERMETER

- BP1, BP2—Insulated binding posts
- C1, C2—100- μ F, 50 VDC capacitors
- D1, D2, D3, D4—1-A, 400-PIV diode
- M1—0-1 mA DC meter
- R1—8-ohm, 100-watt resistor, see text
- R2—5000-ohm linear taper potentiometer

Voltage	Watts at 8 ohms
20.0	50
17.9	40
15.5	30
14.1	25
12.6	20
11.0	15
9.0	10
6.3	5
2.8	1
2.0	0.5

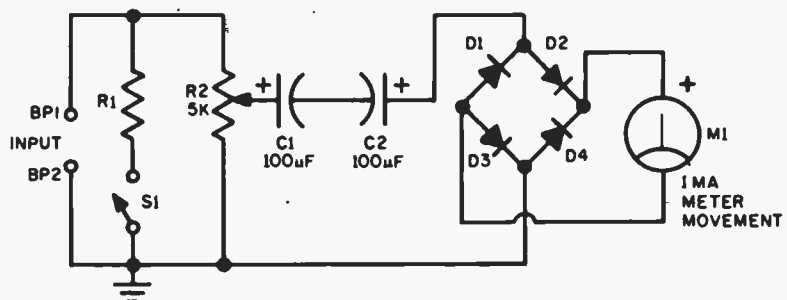

scale indication on meter M1. Seal R2's shaft with a drop of Glyptol or nail polish. Reduce the voltage across

the binding posts in accordance with the table shown and mark the meter scale accordingly.

24 Audio Distortion Meter

□ This 1-kHz distortion meter is extremely accurate and is handy for measuring the distortion of power amplifiers.

Resistor Rx is the load resistor for the amplifier; 4, 8 or 16 ohms at the appropriate power rating. The AC meter can be a VTVM or a 20,000 ohms/volt or higher VOM. Adjust the amplifier for the desired power output, set switch S1 to the calibrate

position and note the meter reading. Set S1 to the THD (Total Harmonic Distortion) position and adjust both coil L and resistor R for the *minimum* meter reading.

The percent harmonic distortion is

equal to the *minimum* reading divided by the *calibrate* reading x 100.

The circuit works by filtering out the 1-kHz fundamental signal with the L1/C1/C2/R1 T-notch filter. What's left is the harmonic content.

PARTS LIST FOR AUDIO DISTORTION METER

- C1, C2—0.01- μ F, 100-VDC capacitor, 5%
- L1—UTC VC-15 variable inductor (Do not substitute)
- R1—500,000-ohm pot
- Rx—Amplifier load resistor (see text)
- S1—Dpdt switch

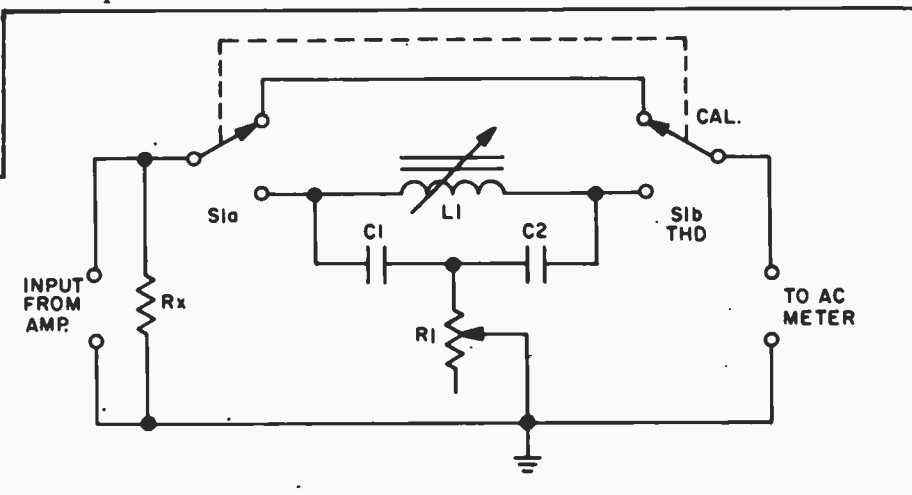

25 Hi-to-Lo Z Mike Amp

□ Try to run a high impedance mike line for more than 25 feet and you're sure to get high frequency losses and hum pickup. But this simple junk-box project mounted in a small metal enclosure on the mike stand will con-

vert the mike's output to a low impedance that can run for hundreds of feet without hum pickup or losses.

The output can be run into any microphone input-rated from 150-ohms up to high impedance. The cir-

cuit serves only to convert high to low impedance; it provides no amplification. A metal enclosure must be used. The Field Effect Transistor, Q1, can be just about any surplus N-channel type.

PARTS LIST FOR HI-TO-LO Z MIKE AMP

- B1—1.5-volt AA battery
- C1—10- μ F, 12 VDC electrolytic capacitor
- Q1—Field effect transistor, Motorola MPF-103
- (Radio Shack 276-2028)
- R1—2-megohm, 1/2-watt resistor
- R2—150-ohm, 1/2-watt resistor
- S1—Spst switch

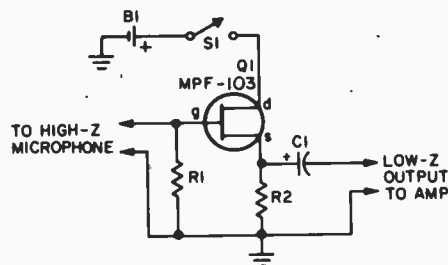

26 Low Power Safety Light

□ Sometimes things that start out as toys wind up as circuit hardware. This device started out as winking bow-tie lights, but its low current consumption of 20 mA or less makes it ideal as a power indicator for "dangerous" or portable equipment where something more is needed than a light that just glows. If you purchase the IC, LEDs and capaci-

PARTS LIST FOR LOW POWER SAFETY LIGHT

- IC1—Type 7400 integrated circuit
- LED1, LED2—see text
- R1, R2—4700-ohms, 1/2-watt resistor
- R3, R4—120-ohms, 1/2-watt resistor
- C1, C2—50- μ F capacitor, rated 6-VDC or higher

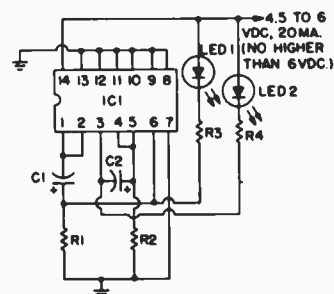

tors from a "surplus" dealer the whole thing should cost less than \$2. The circuit uses a standard 7400 IC as a multivibrator, and the values shown cause the lamps to alternate at a rate of approximately once a second. The timing is determined by the values of R1, R2, C1 and C2,

but it's best not to make the resistance values higher than 4700 ohms. So if you want to change the timing rate you should change the values of C1 and C2. Increasing the capacitance slows down the rate of change.

Any LED indicator rated from 20 to 40 mA can be used. Use what-

ever is least expensive. Four penlight batteries (6-VDC) can be used as a portable power supply, but the circuit will work with only three penlights (4.5-VDC). If you use 4.5-volts try to use 20 mA LEDs for greatest brightness. Ground all unused IC terminals.

27 Headlight Minder

No more dead batteries in the morning; the Headlight Minder lets you know, loud and clear, if your

lights are on when the ignition is off. When the ignition only is on, the tone circuit is off since there is no

complete power path for Q1. Diode D1 prevents positive battery voltage from flowing through Q1 to the

PARTS LIST FOR HEADLIGHT MINDER

- C1—30- μ F, 25-VDC electrolytic capacitor.
- C2—0.25- μ F, Mylar capacitor
- D1—1-A, 50-PIV rectifier
- Q1—HEP-630 pnp transistor
- R1—15,000-ohm, 1/2-watt resistor
- R2—680-ohm, 1/2-watt resistor
- S1—Dpst switch
- Spkr—8-ohm speaker
- T1—500-ohm CT pri. to 8-ohm sec. output transformer, Lafayette Radio Electronics 33 R 85572

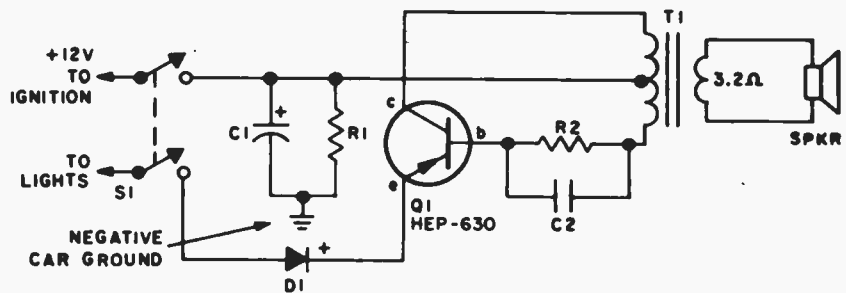

lights. When lights and ignition are on, Q1's collector and emitter are positive and the tone generator remains off. When the lights are on and the ignition is off, Q1's (ground) ter-

minal through R1 and the generator sounds off. You'll know you left the lights switched on.

The unit can be built in a metal cabinet fastened to the car's dash-

board so R1 is connected through the cabinet to the car's chassis, thereby completing a negative battery connection.

28 Slide Show Stopper

Soundless slide shows are dull, dull, dull! But a stereo recorder can automate the whole show so slides change automatically in step with the commentary.

Record your commentary on the left track. At the instant you want slides to change, record a one-second noise or tone burst on the right track. Connect the programmer between the recorder's right speaker output and the projector's remote control cable. Make a test run to determine the right-track volume setting to make noise or tone bursts activate relay K1. No fancy tone generators needed here. Just give a hearty Bronx cheer into the mike of the left channel only!

Then start the tape from the beginning. The audience will hear your

commentary or spectacular music-and-sound reproduction through a speaker connected to the recorder's left channel, while the signal on the right channel automatically changes the slides.

PARTS LIST FOR SLIDE SHOW STOPPER

- C1—25- μ F, 50-VDC electrolytic capacitor
- D1, D2—1-A/400-PIV silicon rectifier, Motorola 1N4004
- K1—2500-ohm coil plate-type relay
- T1—5000-ohm CT audio output transformer

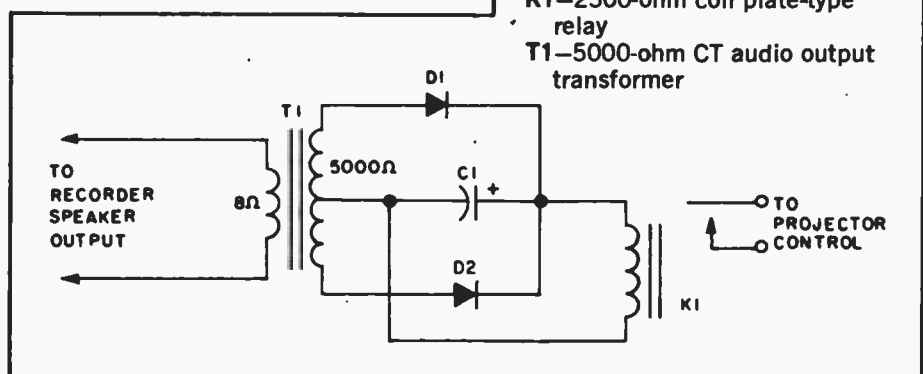

29 Fail-Safe Emergency Light

□ Next time the power fails there's no need to stumble around in the dark looking for a flashlight, for this emergency light will automatically turn on a battery lamp as soon as the power fails. This same type of emergency lighting is now required in many pub-

lic buildings.

As long as there's AC on the powerline relay K1 contacts are held open breaking the battery-to-lamp circuit. When power fails the wiper on K1 springs back, closing the battery-to-lamp circuit.

The lamp is one of those inexpensive battery-operated closet lamps sold by mail order houses. They normally work off two C-cells (3 volts), so you'll have to replace the bulb with a 6-volt flashlight or high intensity bulb. Don't try to use the existing batteries and bulb; the C-cells won't run long enough. The lantern battery has a shelf life of about 2-years in standby service. To be sure of lighting when you need it, affix a label to the battery showing the date it should be replaced.

Relay K1 can be any *continuous duty* 117 VAC model with spdt contacts. Note the lighting circuit connects to the relay contacts that are *open* when K1 is energized.

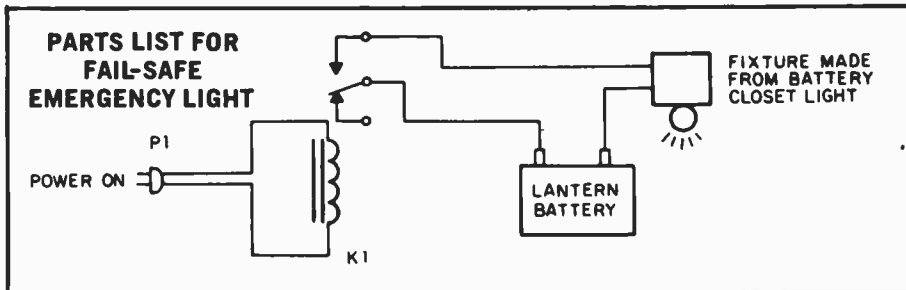

30 Lo-Cost Lamp Dimmer

□ With miniature components and extreme care you can build a low power lamp dimmer right into a socket. Without a heat sink, Triac Q1 handles up to a 200-watt lamp. Instead of a relatively expensive trigger diode, an ordinary neon lamp of the NE-2 variety can be used.

Because the neon does not trip the gate until it conducts, the lamp turns on at medium brilliance. The lamp can then be backed off to a soft glow. Because the neon drops out when the applied voltage falls below the neon holding voltage of approximately 40V the lamp cannot adjust as low as it can with a diode trigger.

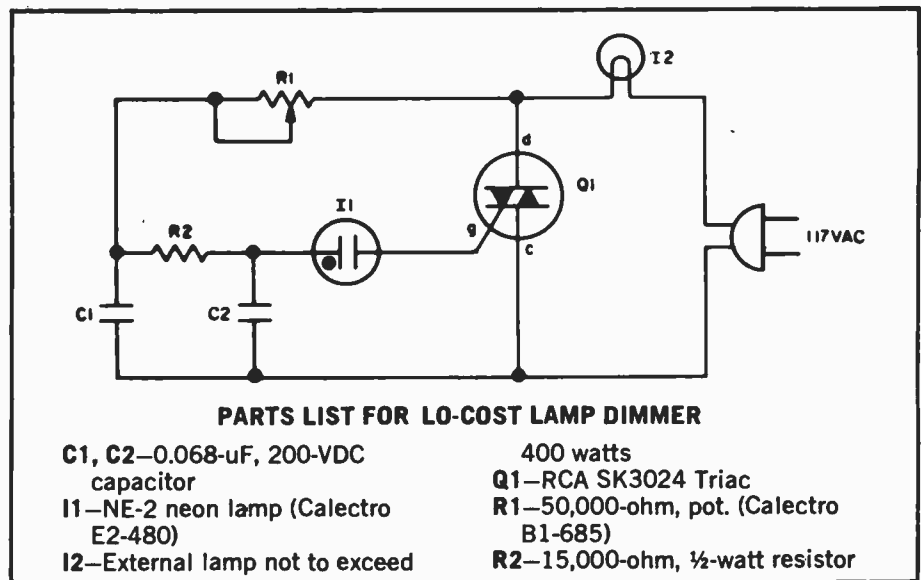

31 Bull Horn

□ The next time someone tries to outshout you at a public meeting just reach for this Bull Horn and drown 'em out.

With a little ingenuity the circuit can be built into a small metal cabinet that secures directly to the 6-volt lantern battery power supply. Speaker SPK-1 can be anything from 4- to 8-ohms impedance, but a miniature PA horn or "trumpet" will give much greater volume with no increase in

battery drain since the horns are very efficient.

Note there is no main circuit ground. Transistors Q1 and Q2 must be heat sunk. Since Q1 and Q2's collectors are connected to the heat sink mounting tab you can secure the transistors directly to the cabinet if you use the ground indicated by the dashed lines. If you connect the battery's negative wire to the cabinet (ground) you must insulate Q1 and

Q2 from the cabinet with *insulated* power transistor mounting hardware.

Potentiometer R1 is used to compensate for different carbon microphone values, and for reduced battery voltage. Normally, a Bull Horn gets very distorted as the battery wears down. With this circuit, however, you can compensate somewhat for battery wear with R1, getting up to 25 percent extra use from the battery. Wire R1 so maximum resistance is in

the circuit when R1's shaft is full counterclockwise. A linear taper pot will give the easiest control.

M1 can be any carbon microphone; from a surplus telephone transmitter to the element from an old, scrapped CB rig's microphone. If you get one of the war surplus carbon mikes you can use the built in push-to-talk (PTT) switch for S1.

To use, set R1 full counter-clockwise and turn S1 on. As you speak into the mike adjust R1 very slowly for *cleanest* sound, or maximum understandable volume. This adjustment compensates the circuit for the microphone impedance and, once set, you can leave it alone. Later, to stretch the battery life, adjust R1 slightly clockwise as the distortion (caused by reduced battery voltage) increases. Do not use the Bull Horn when the distortion is very bad and R1 is full clockwise as this will damage the transistors: get a new battery.

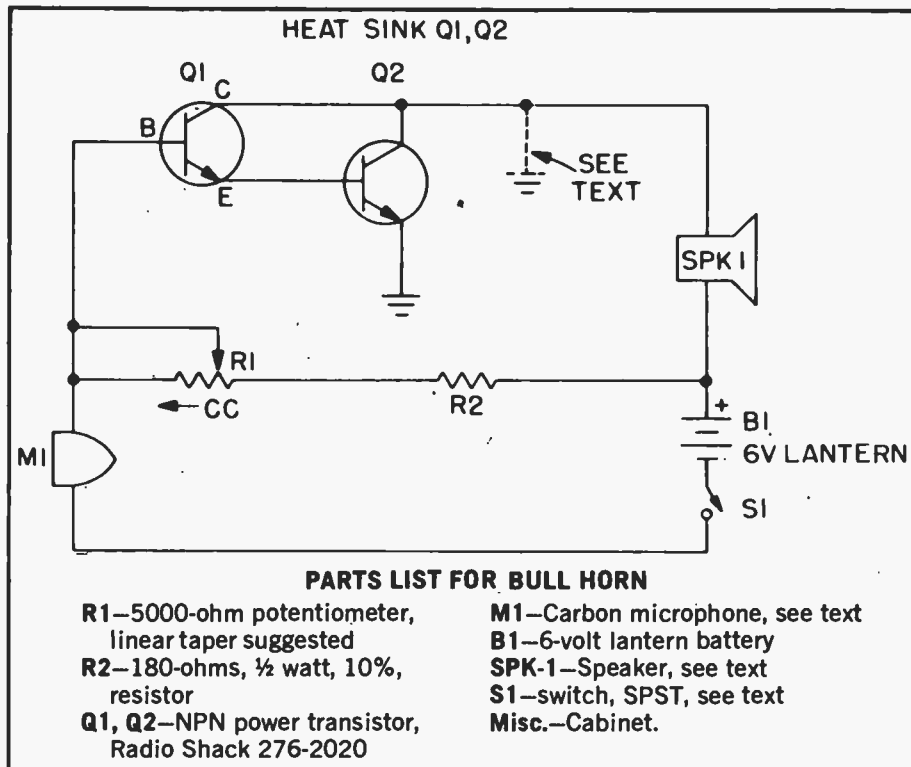

32 Easy to Build Speech Clipper

□ An effective speech clipper for transmitters and PA systems can be made from only two diodes and a capacitor.

Connect the diodes to the collector of the microphone preamplifier, the stage with at least a 1V peak-to-peak audio output voltage. The diodes clip

at approximately .2V, allowing overall amplifier gain to be increased without speech peaks producing over-modulation or excess peak power output.

Capacitor C1's voltage rating must be at least equal to the DC supply voltage at the preamp collector. If

the preamp uses a negative supply, reverse C1's polarity. The output level to the rest of the amplifier is determined by R1. If the diodes cause distortion in the preamplifier, add resistor Rx, as shown. Use the necessary value between 1000 and 10,000 ohms.

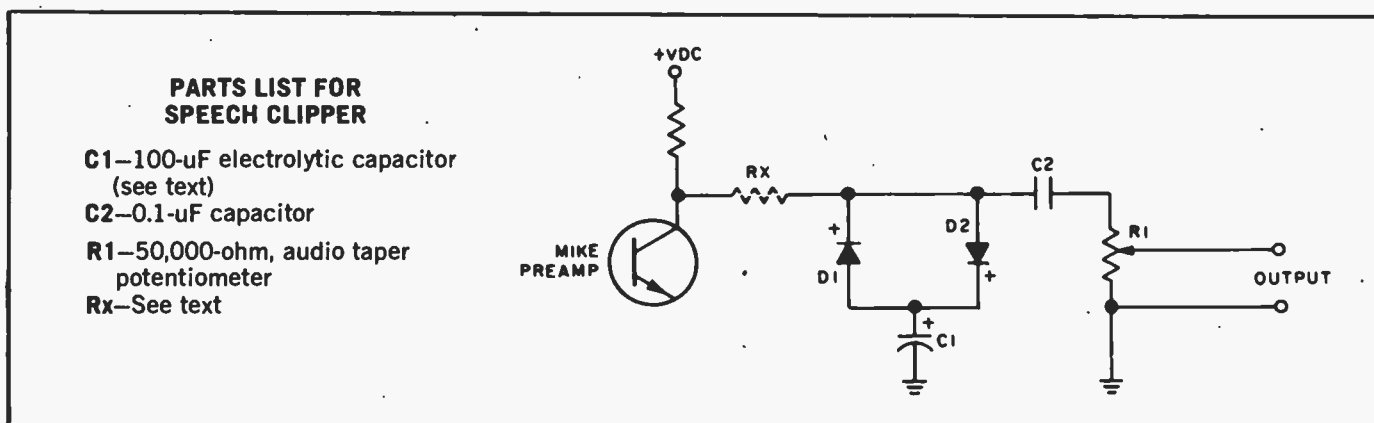

33 Simple RFI Filter

□ It is not uncommon for nearby communications transmitters, and even AM and FM broadcast transmitters to be heard in hi-fi amplifiers that are switched to the phono input.

The reason is that the input preamplifier in the hi-fi makes a dandy RF detector for any radio signal(s) picked up by the connecting lead from the turntable. After everything

else, such as grounding equipment and installing power line filters, fails to get rid of the interference, try installing this simple RFI (radio frequency interference) filter in series

with the input lead to the preamplifier. Best results are attained if the filter is as close as possible to the preamp input transistor itself. But if it means cutting into the printed circuit board's wiring, place the filter at the input to the PC board wiring—where the wire from the phono input jack connects to the copper foil terminal. Make certain C1 and C2 connect to the copper foil ground. The values of the filter have no effect on audio

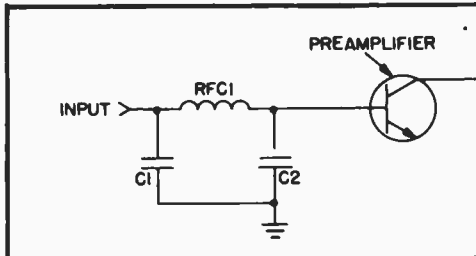

PARTS LIST FOR SIMPLE RFI FILTER

- C1, C2—240-pF dipped Mylar or silver mica capacitor
- RFC1—10- μ H miniature RF choke, J. W. Miller 75F105AP or equiv.

frequencies. Keep in mind that the filter might also fail. Not every RF filter works

the same way in every circuit. There are some RF interference problems that just won't go away.

34 Stereo Beat Filter

Many early stereo tuners, and quite a number of modern budget priced stereo tuners, have considerable output at 19 kHz and 38 kHz from the stereo pilot system. While these frequencies aren't heard, they can raise havoc if they leak through to a Dolby noise reduction encoder, or if the frequencies beat with a tape recorder's bias frequency or its harmonics. Normally, Dolby-equipped units have a 19 kHz filter specifically to avoid the problem of pilot leakage from the tuner, but often the pilot interference is so high it still gets through.

This filter, which can be powered

by an ordinary transistor radio type battery, is connected to the output of the FM stereo tuner, and provides approximately 12 to 15 dB additional attenuation at 19 kHz and about 25 dB attenuation at 38 kHz. It has virtually no effect on the frequency response below 15 kHz, the upper limit of frequencies broadcast by FM stations.

The only really critical components are C1, C2 and R4, and no substitutions should be made.

A signal generator is required for alignment. Feed in a 1 kHz signal and note the output voltage. Then change the generator to 10 kHz and adjust

R5 so the output level at 10 kHz is the same as for 1 kHz. You might have to check the measurements several times to get R5 set correctly. When properly adjusted there will be perhaps 1 dB loss at 15 kHz.

The input signal should be in the range of 0.1 to 1 volt—typical level from a tuner's tape output jack.

PARTS LIST FOR STEREO BEAT FILTER

- Resistors 1/2-watt, 10%, unless otherwise specified
- R1—470,000-ohms
- R2—220,000-ohms
- R3—33,000-ohms
- R4—33,000-ohms, 5%
- R5—5,000-ohm linear taper potentiometer
- R6—3,300-ohms
- Capacitors rated 10-VDC or higher
- C1—0.047- μ F
- C2, C3—220-pF, 2% silver mica or equiv.
- C4—25- μ F
- C5—1- μ F
- Q1—Transistor, Radio Shack 276-2009
- Q2—Transistor, Radio Shack 276-2021

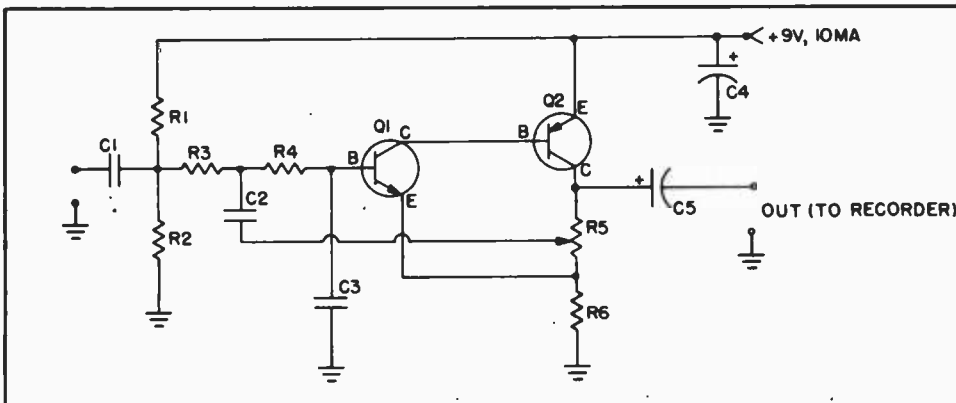

35 Record Restorer

Old 78-rpm collector's-item records cut back in the early days when performers sang in front of a large horn usually have a peak in the mid-band that drives the sound into your mind like a fingernail scratched across a blackboard. The overall sound quality is easily tamed, and made more natural and modern, by attenuating the shrill peaks with a Record Restorer, a device that sup-

PARTS LIST FOR RECORD RESTORER

- C1, C3—0.25- μ F mylar capacitor
- C2—0.02- μ F mylar capacitor
- R1—270,000-ohm, 1/2-watt resistor
- R2, R3—50,000-ohm potentiometer, linear taper

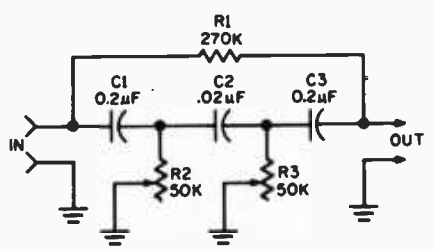

presses, by hi-fi standards, the mid-band frequencies.

The Record Restorer should be assembled in a metal cabinet to prevent hum pickup. Connect the output of

your phonograph to the restorer input. Connect the output of the restorer to your tape recorder. Set potentiometer R2 to maximum resistance and adjust potentiometer R3 for

the most pleasing sound. If R3's adjustment is too little, or too much as evidenced by a "hole" in the sound quality, trim the restorer with R2 until you get the optimum equalization.

36 FM Overload Filter

□ A simple filter is all it takes to remove a strong, local FM signal that is blocking or cross modulating other FM stations. The filter connects in series with the FM antenna's downlead. Just be sure to use the shortest possible length between the filter's output and the receiver.

The filter *must* be assembled in a metal cabinet with 1/4-in. access holes so you can adjust the trimmer tuning capacitors. The metal cabinet is grounded to the receiver's chassis. Switch S1 by-passes the filter for normal operation. If your antenna's

downlead is coaxial cable, only one filter is installed—in series with the center (hot) conductor. To adjust,

PARTS LIST FOR FM OVERLOAD FILTER

C1, C2—40-pF trimmer capacitor
RFC1, RFC2—0.22-uH RF choke, any type
S1—Dpst slide switch
Misc—300-ohm twinlead, metal cabinet

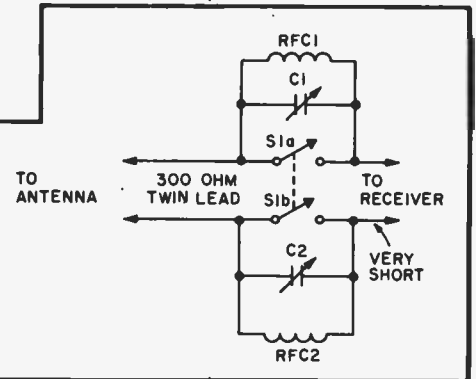

tune in the offending station and use an insulated alignment screwdriver to

adjust trimmer capacitors C1 and C2 for *minimum* signal strength.

37 Hook-up Remote Speakers

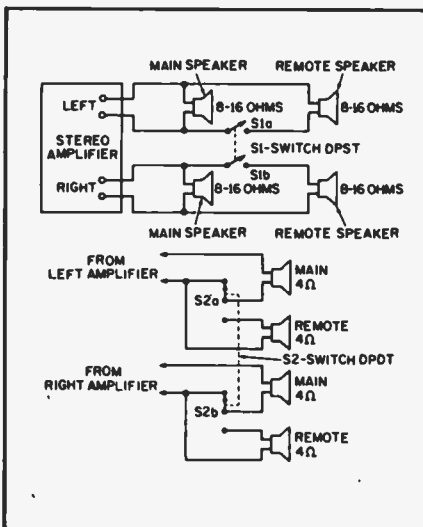

□ Even if your hi-fi amplifier does not have output terminals for remote speakers, it is easy enough to add them without complex switching equipment. With few exceptions, modern solid-state amplifiers have no output transformer and automatically match any speaker impedance between 4 and 16 ohms. The only important consideration is that the total impedance connected to the left and/or right speaker output is never less than 4 ohms, or the amplifier will attempt to deliver so much power output, the output transistors will self-destruct.

If your main speakers have an impedance of 8 or 16 ohms, simply add

remote speakers as shown; switch S1 turns the remote speakers on and off. Since transistor amplifiers usually put out more power at 4 ohms than at 8 or 16 ohms, adding the extra speakers does not substantially reduce the volume at the main speakers because the amplifier sees a lower impedance load and attempts to drive more power output into the combined speaker load.

If your speakers are 4 ohms, and you plan to use 4 ohm remote speakers use the circuit modification shown. Switching in the remote speaker will result in the main and remote speakers being series connected for a total load of 8 ohms.

38 Audio Z-Matcher

□ Headphone outputs aren't standard. On some equipment the phone output might be low impedance such as for hi-fi type headphones; on other equipment the phone output might be "high Z" such as 1,000 or 10,000 ohms. Connect low-Z phones to a high-Z output and the volume level will fall to next-to-nothing, and distortion might soar to unpleasant values.

But use a Z-Matcher, actually a low-to-high matching transformer,

and you can use just about any phone on any circuit. Don't let the 4 and

PARTS LIST FOR AUDIO Z-MATCHER

T1—Audio output transformer; 4-8-ohm primary, 10,000-ohm secondary

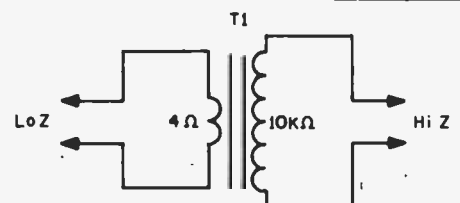

10,000-ohm markings fool you. Any low-Z phone from 4 to 20 ohms connects to the 4-ohm transformer terminals; any high-Z phone connects to

the 10,000-ohm terminals. For example, if you are using 8-ohm hi-fi phones and a recorder with a 5000-ohm phone output, connect the 8-ohm

phones to the 4-ohm terminals and the 10,000-ohm terminals to the recorder. An exact match isn't critical.

39 Budget Mike Mixer

Using components often found in an experimenter's junk box, this two-channel mike mixer handles high impedance or dynamic microphones. Level controls R1 and R2 should not be run wide open with hi-Z mikes since the input impedance then becomes the value of R3 and R4, or

100,000 ohms. If a hi-Z mike is loaded by less than 1 megohm, the low frequency response of the mike is attenuated.

Transistor Q1 can be almost any general purpose type such as the 2N107 or 2N217. However, the better the transistor, the better the sig-

nal-to-noise ratio. Top quality high-gain transistors should not be used since relatively high leakage current of experimenter-grade transistors provides the base bias current. Transistors with low leakage might produce high distortion because of low "internal" base bias.

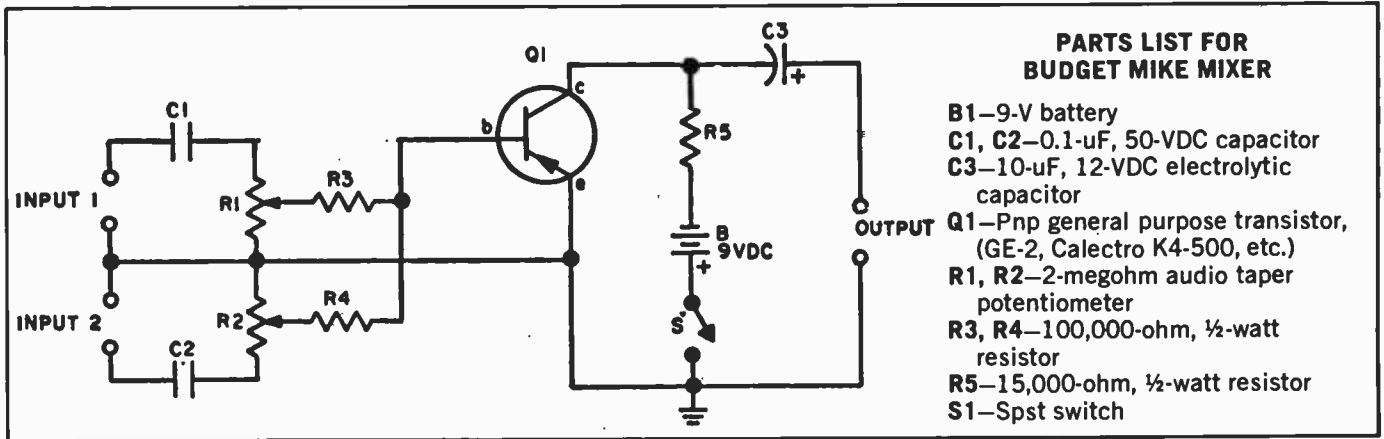

40 Stereo Balance Meter

One sure way to be certain your sound system is in perfect electrical balance is to use a power amplifier stereo balance meter to substitute for guesswork.

Meter M1 can be a zero-center DC milliammeter rated 1-0-1 mA or less. Alternately, you could use a standard meter but the pointer might be driven off-scale to the left while making adjustments, though the meter won't be damaged—it will just be an inconvenience.

Play any stereo disc or tape and then set the amplifier to *mono*. Adjust

the left and right channel balance until meter M1 indicates zero; meaning the left and right output level are identical—that's balance.

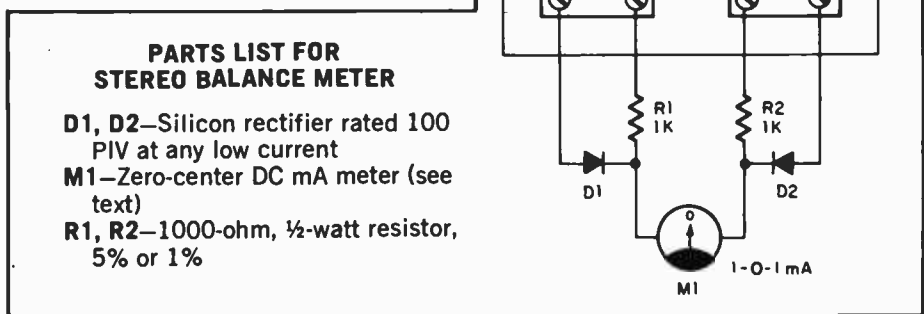

41 Magnetizer-Demagnetizer

Quite often it's most handy to magnetize your tools to start a screw or nut into a blind spot. On the other hand, there are times when your tools must have absolutely no trace of magnetism, such as when adjusting a tape

recorder's heads. This easy device can flip your tools either way, at any time. All it takes is the press of a button.

Coil L1 is an ordinary TV focus coil. Using an ohmmeter, locate two pair of leads. Short one lead from

each pair together and connect the coil into the circuit as shown. Assemble the unit in a plastic (not metal) cabinet using zip, or lamp, wire about 12-in. long for L1's connections.

To magnetize a tool, place switch S1 in the M position, insert the tool into L1's opening and depress switch PB1 for about 1 second. Release PB1 and then withdraw the tool. To demagnetize, place the tool inside L1, set S1 to D and depress PB1. While holding PB1 down slowly withdraw the tool from L1. If the unit fails to magnetize reverse the connections of one pair of L1's leads.

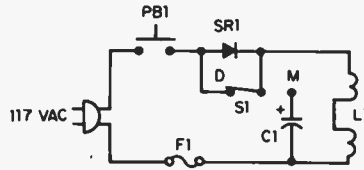

PARTS LIST FOR MAGNETIZER-DEMAGNETIZER

- C1—40- μ F, 200 VDC capacitor
- F1—5-ampere fuse
- L1—TV focus coil, see text
- PB1—normally-open pushbutton switch
- S1—Spdt switch
- SR1—Silicon rectifier, 400 PIV, 1 A.

42 Add-A-Tweeter

Any single-voice coil speaker is hard pressed to handle both low and high frequencies simultaneously—and it's the highs that suffer most. A much cleaner sound can usually be obtained from speakers 6 inches or larger if the highs are pumped through a tweeter. It can be any small speaker rated 4 to 6 ohms of approximately 2 to 3 inches in diameter.

The back-to-back capacitors, C1 and C2, permit only the highs from

about 1500 Hz up to pass into the tweeter. By keeping the lows out of the tweeter, the highs come out cleaner, and there's no chance of the greater low frequency power "blowing" the tweeter. Potentiometer R1 is used to match the tweeter's output level to that of the woofer—because small speakers are generally much more efficient than large speakers. If you eliminate R1, the highs will literally scream in your ears.

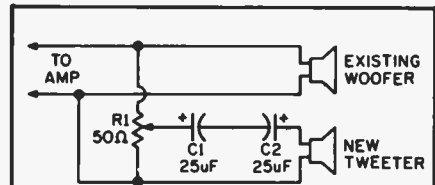

PARTS LIST FOR ADD-A-TWEETER

- C1, C2—22- μ F electrolytic capacitor, 50 VDC
- R1—50-ohm wirebound potentiometer, 1 or 2 watts.
- Misc.—Cone type tweeters are suitable for use with this circuit.

43 Mike Input Generator

You can always feed an audio generator into a mike input to check an AF system, but how do you check the mike? Saying "woof, woof, hello, test" gets mighty tiring. Instead, clamp the generator to the front of the mike with a rubber band and you'll send continuous tone through the mike. It lets you take your time checking the mike, connecting cable, jacks, amplifiers, etc.

The beeper can be built in a small plastic case—nothing is critical. The speaker may be any size from one to three inches.

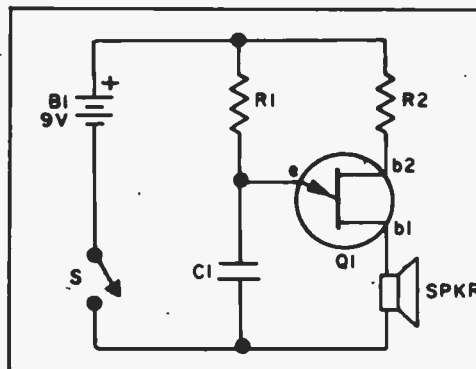

PARTS LIST FOR MIKE INPUT GENERATOR

- B1—Type 216 9-V battery
- C1—0.1- μ F, 50-VDC capacitor
- Q1—Unijunction transistor—HEP-310 (Radio Shack 276-2029)
- R1—10,000-ohm, 1/2-watt resistor
- R2—47-ohm, 1/2-watt resistor
- S1—Spst switch
- Spkr—8-ohm miniature speaker

44 Automatic Hi-Fi Shutoff

It happens to just about everyone. One minute you're listening to the hi-fi, the next you're called away to answer the doorbell or a phone call. You forget all about the music, the record plays through, the automatic turntable shuts off—but the amplifier stays on until you happen to pass by

and notice the glow from the pilot lamps. Yet, this simple circuit, which you can throw together in less than an hour, will automatically turn off the amplifier when the turntable shuts off.

The relay coil voltage is taken from across the phono motor; when

the turntable motor is on, relay K1 closes and applies power to AC socket SO1; when the turntable shuts off, removing voltage from the motor, K1 opens, disconnecting power from the outlet. Because the turntable automatic shutoff switch might not be able to carry the amplifier load, the

AC power for SO1 is taken off before the automatic shutoff switch. Switch S1 bypasses the relay contacts and applies power to the socket even when the turntable is off.

PARTS LIST FOR AUTOMATIC HI-FI SHUTOFF

- K1—117-VAC relay with contacts rated at least 5 amperes at 117 VAC (Calectro D1-980 or equiv.)
- S1—Switch, Spst (shutoff bypass)
- SO1—AC socket (Calectro F3-100)

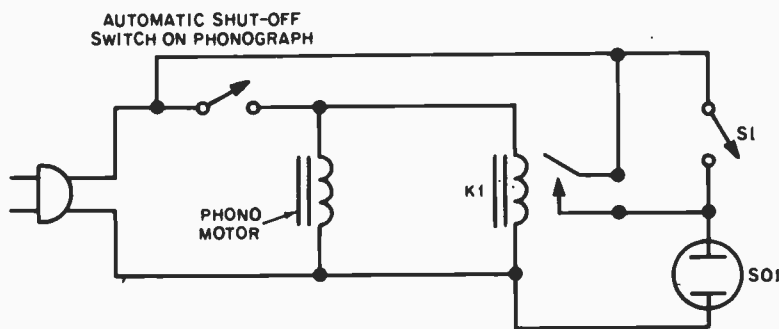

45 Tape Dubbing Filter

□ Next time a friend asks you to dub his old 78 or worn 45 record collection on tape, don't start telling him how it will come out with more scratch and noise than music. No need to apologize. Just pass his records through the Tape Dubbing Filter and he'll never know *wh' hoppen'* to the noise—it will all be gone.

The filter connects between the signal source such as a record player and your tape recorder. Its cut-off frequency starts at about 5000 Hz, attenuation increasing at the higher noise producing frequencies. Control R2 allows you to shift the "corner"

frequency slightly up or down to obtain more or less high frequency attenuation as needed. For proper operation, the recorder input impedance should be at least 100,000 ohms.

Some solid state recorders with input impedances less than 100,000 ohms will reduce the degree of high frequency noise filtering. This unit should be built in a metal enclosure.

PARTS LIST FOR THE TAPE DUBBING FILTER

- C1, C2—330-pF disc capacitor, 500 VDC or better
- R1—100,00-ohms, ½-watt resistor
- R2—100,000-ohm potentiometer, any taper

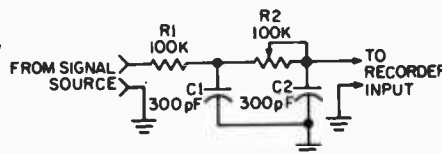

46 Tape Dubber's Pad

PARTS LIST FOR TAPE DUBBER'S PAD

- PL1, PL2—Plugs to match existing tape equipment shielded cable
- R1—100,00-ohm, ¼-watt resistor
- R2—10,000-ohm, ¼-watt resistor

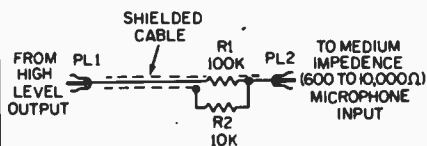

□ Many cassette recorders do not have a high level (aux) input; they are meant only for use with microphones. If you try to dub directly from another recorder's "line" output, or from across the speaker, the relatively high signal level overloads the microphone input, causing severe distortion.

Good dubs can be obtained by attenuating the high level signal almost 50 dB, so the attenuated signal is essentially equal to microphone

level. This recorder bridging cord provides about 50 dB attenuation in a single, easy-to-handle assembly. Connect resistor R1 in series with the shielded cable hot lead. Connect the free end of R1 to recorder plug PL2 and one end of resistor R2. Fold R2 back adjacent to R1 and solder the free end to the cable shield. Loop a wire from the shield to the PL2 outside (sleeve) terminal. PL1 should match the output jack of the recorder you dub from.

47 100 kHz Marker Oscillator

□ This 100-kHz marker oscillator provides output from 100 kHz to about 30 MHz, and can be built from salvaged components. Only the crystal is critical; it must be 100 kHz and can be ordered from JAN Crystal

tals, 2400 Crystal Drive, Ft. Myers, FL 33901. Send ten cents for their catalog.

Trimmer capacitor C1 is used to zero beat the marker's output to National Bureau of Standards station

WWV at 2.5, 5, 10, 15, 20 or 25 MHz—whichever frequency you receive best. For maximum stability C2 should be a silver mica, but an ordinary dipped Mylar will work well; you simply might have to readjust

C1 more often. Do not make C5 any larger than 25- or 27-pF.

Note that two bypass capacitors—C3 and C4—are required. C3 should be as close as possible to RFC1. C4 can be near the battery. If you have a 2.5-mH choke lying around you should try it out before buying a 1-mH choke for RFC1, because 2.5-mH will probably work in your circuit. Transistor Q1 can be any high frequency, silicon NPN of the 2N2222 type. Battery B1 is the 2U6 type such as used in small transistor radios.

To use the marker simply place the output wire (about 12 inches long) near the receiver's antenna input. If the markers aren't strong enough at the higher frequencies try clipping the wire to the antenna terminal.

The unit can be assembled on an open perfboard or in a plastic cabinet.

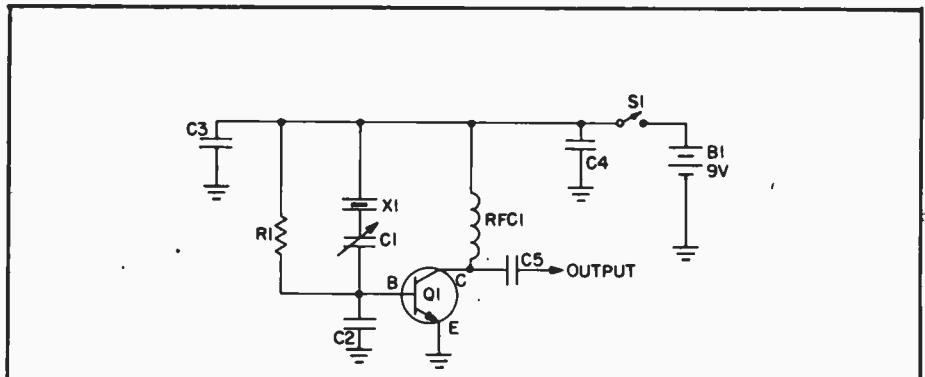

**PARTS LIST FOR
100 KHZ MARKER OSCILLATOR**

- R1—470,000-ohms, ½-watt, 10%, resistor
- C1—5-to 50-pF trimmer capacitor
- C2—390-pF silver mica capacitor, see text
- C3—100-pF ceramic disc capacitor
- C4—0.001-uF ceramic disc

- capacitor
- C5—25- or 27-pF ceramic disc capacitor
- RFC1—1-mH RF choke
- Q1—NPN transistor, 2N2222, (RS 276-2009 or equiv.) see text
- X1—100 kHz crystal, see text
- S1—Switch, SPST
- B1—Battery, 9-VDC, type 2U6 or equiv.

48 Crystal Activity Checker

**PARTS LIST FOR
CRYSTAL ACTIVITY CHECKER**

- B1—9-volt transistor radio battery
- C1—50-pF disc capacitor, 100 VDC or better
- C2—0.005-uF disc capacitor, 25 VDC or better
- C3—33-pF disc or mica capacitor, 100 VDC or better
- D1—Diode, 1N60
- M1—Meter, 0-1 mA DC
- PB1—Normally open push button switch
- Q1—NPN transistor, HEP-50 (Radio Shack 276-2009)
- R1—100,000-ohm, ½-watt resistor
- R2—10,000-ohm, ½-watt resistor
- RFC—2.5-mH RF choke
- SO1—Socket to match crystals, see text

□ A fast way to see if the crystal from your transmitter or receiver is properly "active" is to compare its output against that of a known good crystal. This crystal checker will handle both fundamental and overtone type crystals.

Socket SO1 should match the pins on your crystals. If you use more than one type of crystal, install two (or more) sockets in parallel. The unit can be assembled in any type of cabinet.

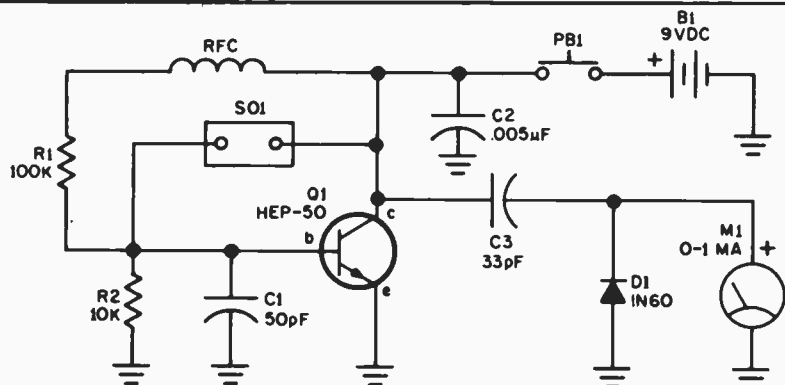

To test a crystal's activity, first plug in a known good crystal, depress push button switch PB1 and note the meter reading. Then install the questionable crystal, press PB1 and note

its meter reading; if it's good its output should approximate that of the reference crystal. Take care that you don't compare apples with oranges; the reference crystal should be the

exact same type as the crystal to be tested. If good crystals drive the meter off scale, install a 1000-ohm, ½-watt, 10 percent resistor in series with meter M1.

49 455 kHz Alignment Osc.

□ Using a 455-kHz crystal, this generator provides a signal for testing and aligning radio IF circuits. The unit is built on a perfboard or some other rigid mounting to achieve good

circuit stability. A metal cabinet reduces radiation so the signal fed to the receiver will be primarily determined by level control R2.

To align the completed circuit, ad-

just L1's slug for maximum S-meter reading in a receiver or connect R2 to an oscilloscope and adjust L1 for maximum output.

Turn the power supply on and off

several times to make certain the oscillator starts consistently. If the oscillator fails to start every time, adjust

L1's slug *slightly* until you obtain immediate and consistent starting each time the power is applied.

**PARTS LIST FOR
455 KHZ ALIGNMENT OSC.**

C1—0.05- μ F, 25-50 VDC capacitor
C2—47-pF silver mica capacitor
C3—15-pF silver mica capacitor
L1—3.4-5.8 mH RF coil
(J. W. Miller 21A473RB1)

Q1—HEP 641 (Radio Shack 276-2002)
R1—330,000-ohm, 1/2-watt resistor
R2—5000-ohm pot
XTL—455-kHz crystal

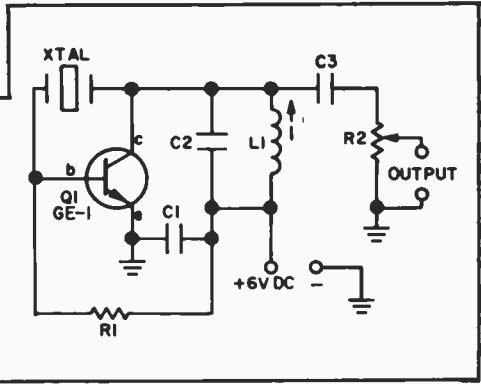

50 Fancy Flasher Lamp

□ The ballgame is over and your car is buried in the parking lot along with two thousand other cars of the same color. Only yours isn't lost. Sticking above acres of metal is a little lamp going *blink-blink-blink*.

Mount the No. 49 lamp at the top of the antenna and run two wires down to the control unit inside the car. When switch S1 is turned *on* the multivibrator makes the lamp blink away. Changing the capacitor's value will vary the blink rate.

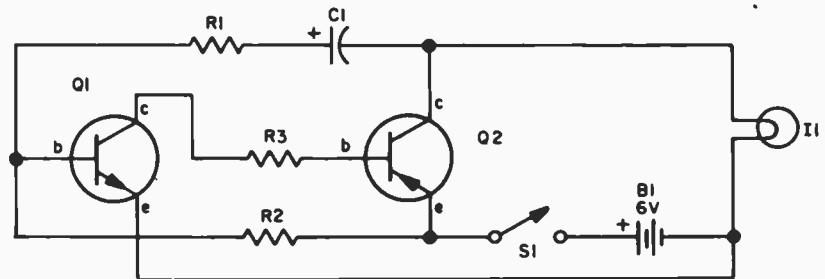

**PARTS LIST FOR
FANCY FLASHER LAMP**

B1—6-volt lantern battery
C1—2- μ F, 25-VDC electrolytic capacitor
I1—No. 49 pilot lamp
Q1—npn transistor, HEP-641

(Radio Shack 276-2002)
Q2—pnp transistor—HEP-739
R1—470-ohm, 1/2-watt resistor
R2—1-megohm, 1/2-watt resistor
R3—2700-ohm, 1/2-watt resistor
S1—Spst switch

51 Logic Probe

□ Most of the digital equipment used by the hobbyist is easily serviced with a logic probe, a device that shows when a digital input or output is at a logic low (0) or high (1). This probe, using an LED for an indicator, is more or less the standard test probe circuit—the type often sold for \$20 or more; yet you can build it for under \$7, with most of the cost representing the test probe assembly itself.

Transistors Q1 and Q2 can be just about any NPN silicon of the 2N2222 type. LED-1 should be one of the "surplus" LEDs rated for 20 to 40 mA, with 20 mA preferred.

Resistor R1 should be placed as close as possible to the test probe tip by wiring. Build it directly into the test probe itself, or build the whole thing into a Keystone test probe assembly, available from some

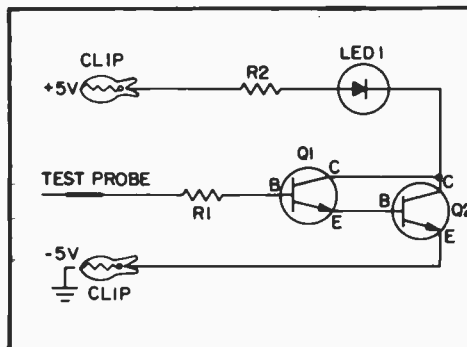

**PARTS LIST FOR
LOGIC PROBE**

R1—27,000-ohms, 1/2- or 1/4-watt, 10%, resistor
R2—150-ohms, 1/2- or 1/4-watt, 10%, resistor
LED-1—See text
Q1, Q2—NPN transistor, 2N2222 (Radio Shack 276-2009 or equiv.)
Misc.—Alligator clips and test probe or test probe assembly.

local radio parts distributors or from Custom Components, Box 153, Malverne, N.Y. 11565, \$5 prepaid. If you build the entire device in the Keystone probe mount all components should be secured firmly to the supplied perf-board strip and R1 mounted near the test tip.

The +5 volt alligator clip connects

to the TTL system's positive supply voltage. The -5 volt alligator clip connects to the -5 volt terminal or ground. The test probe connects to the various inputs and outputs. LED-1 will light when the test probe is touched to a logic high (1). It will remain out when the probe is touched to a logic low (0).

52 Audible Logic Probe

□ One problem when servicing modern IC circuits is that everything is packed in so tight, and IC terminals are so close together, if your test probe slips a fraction of an inch (or centimeter) it's ZAP!, another component bites the dust; and trouble is, solid state breakdowns usually take out a whole string of components.

Logic probes used to trace digital circuits often lead the list in devices that ZAP ICs because you've got to keep one eye on the probe indicator lamp and the other eye on the tip of the test probe. But all that's a thing of the past with this Audible Logic

Probe because you can keep both eyes and your full attention on the tip of the test probe, and a tone indicates a logic low.

Normally, Q1 is cut off (no base input), and there is a small, insignificant voltage drop across R2 so multivibrator Q2-Q3 receives operating voltage and produces an output in the speaker of approximately 700 Hz (at low but comfortable volume). When the probe is touched to a logic low (0) Q1 is still cut off so sound output indicates a low. When the probe is touched to a logic high (1) Q1 is driven to saturation and the

full supply voltage is dropped across R2, so the multivibrator and its output is cut off, indicating a logic high.

Alligator or crocodile clips are used to connect to the TTL equipment's + and - 5-volt terminals. Resistor R1 should be built directly into the test probe to provide good isolation between the TTL equipment and your test lead circuit. Speaker SPK-1 should be rated 20 to 120 ohms—the higher the impedance the greater the volume. 20-, 32- or 45-ohm intercom speakers available on the surplus market are good choices.

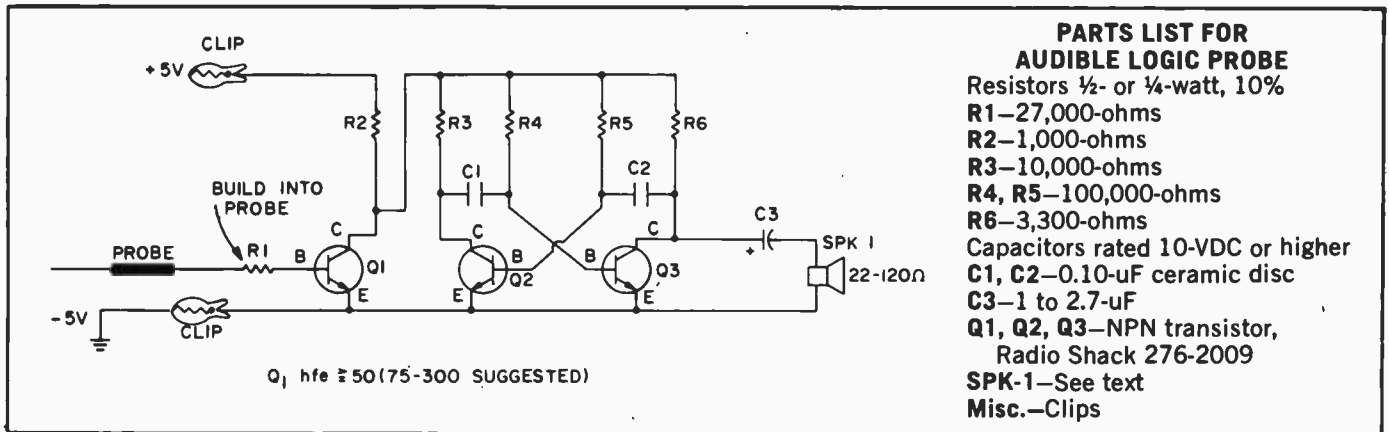

PARTS LIST FOR AUDIBLE LOGIC PROBE

- Resistors $\frac{1}{2}$ - or $\frac{1}{4}$ -watt, 10%
 R1—27,000-ohms
 R2—1,000-ohms
 R3—10,000-ohms
 R4, R5—100,000-ohms
 R6—3,300-ohms
 Capacitors rated 10-VDC or higher
 C1, C2—0.10-uF ceramic disc
 C3—1 to 2.7-uF
 Q1, Q2, Q3—NPN transistor,
 Radio Shack 276-2009
 SPK-1—See text
 Misc.—Clips

53 Sine Wave Squarer

□ Two reverse-parallel diodes of the germanium type provide an emergency square wave generator. Since a germanium diode has an approximate 0.2 V breakover, any sine wave applied to the diodes will be clipped at 0.2 V. It provides a 0.4 peak-to-peak square wave. It's not perfect since the "rise" of the original sine-wave is still present, as shown in the waveform.

To prevent loading and possible

distortion of the sine wave input a 1000-ohm resistor should be connected between the squarer and the generator.

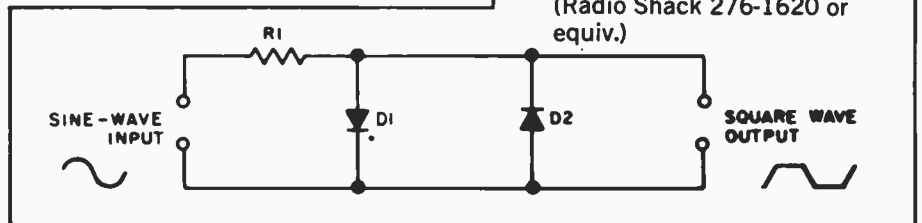

PARTS LIST FOR SINE WAVE SQUARER

- D1, D2—Germanium diode, 1N34 or other general purpose type (Radio Shack 276-1620 or equiv.)

54 Active Square Shaper

□ A quick-and-dirty square wave generator for audio amplifier tests can be fashioned from a standard signal generator and the Square Shaper. Simply drive the Square Shaper with about 1 volt from the generator;

the maximum output at jack J1 will be a square wave of about 1 volt peak-to-peak. Just about any general purpose small-signal transistor can be used for Q1 and Q2, and any resistance value reasonably close to 470-

ohms will be okay for R2 and R3. You can even substitute some surplus PNP transistors such as the 2N404 and 2N109 by simply reversing the polarity of battery B1.

PARTS LIST FOR ACTIVE SQUARE SHAPER

- B1—1.5-V "C" battery
- C1, C2—0.2 or 0.25- μ F, Mylar capacitor
- C3—47- μ F, 3 VDC electrolytic capacitor
- J1—Phono jack
- Q1, Q2—NPN transistor, 2N3394 (Radio Shack 276-2009)

- R1—100,000-ohm, $\frac{1}{2}$ -watt resistor
- R2, R3—470-ohm, $\frac{1}{2}$ -watt resistor
- R4—100,000-ohm audio taper potentiometer
- S1—Spst switch

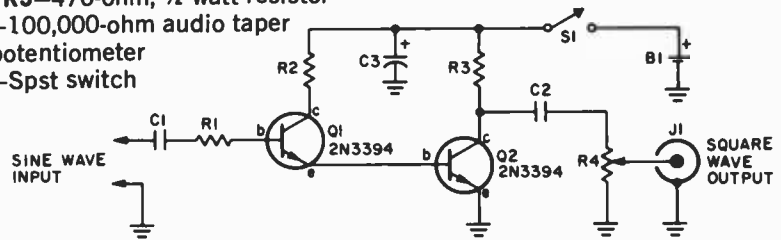

55 Super Sniffer

While a diode and a meter are often all that's required to build a field strength meter (FSM) for transmitters running greater than 1 watt RF output, when it comes to low power walkie-talkies and/or low power RF amplifiers the ordinary FSM won't even budge off its pin. But put a high impedance amplifier between the antenna and the meter and anything in the way of RF output will give you a usable meter reading. You can use a small replace-

ment-type telescopic whip as a "radiation probe" (you don't touch any part of the circuit being tested).

The unit can be assembled in any type of cabinet, though a metal cabinet is suggested to prevent readings from RF picked up by your body. Meter M1 can be any type rated 0-1 mA DC. Normally points A and B are connected together. But if you work with RF circuits of such intensity that the meter is always pinned even if you move the antenna away

from the equipment being tested, insert a 10,000-ohm potentiometer (wired as R1) between points A and B.

Diode D1 should be the lowest cost germanium type, such as the 1N34 or 1N60. Do not use a silicon diode.

The circuit is a bridge and must be balanced. After S1 is turned on adjust potentiometer R1 for a zero meter reading. The meter is then ready for use.

PARTS LIST FOR THE SUPER SNIFFER

- Resistors $\frac{1}{2}$ -watt, 10%, unless otherwise specified
- R1—50,000-ohm linear potentiometer
- R2—1-megohm
- R3—10,000-ohms
- R4—1,000-ohms
- C1—100-pF ceramic disc capacitor
- Q1—FET, Radio Shack 271-2028
- RFC1—1-mH RF choke (for 3 to 30 MHz use)
- S1—Switch, SPST
- B1—Battery, 9 VDC, type 2U6 or equiv.
- M1—Meter, 0-1-mA DC

TELESCOPIC WHIP

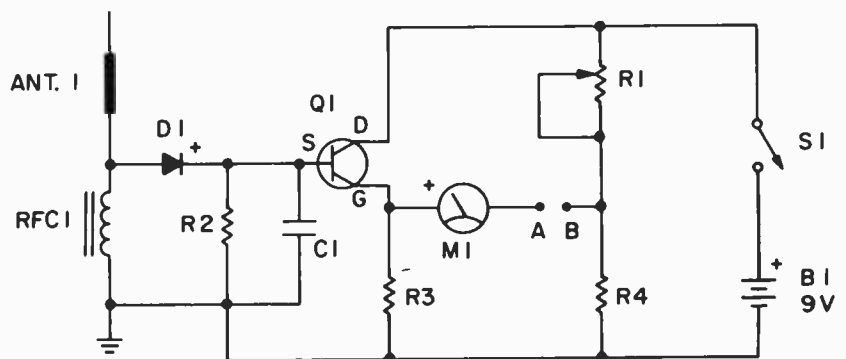

56 Simple AM Mod. Monitor

This simple modulation monitor for AM ham or CB transmitters requires no connection to the transmitter. Just position the loop near the final tank or antenna matching coil until the signal is heard in the headphones.

PARTS LIST FOR SIMPLE AM MOD. MONITOR

- C1—100-pF disc capacitor
- D1—1N914 diode
- E1—Magnetic headphone, 2000 ohms or better
- L1—Coil, 3 turns on $1\frac{1}{2}$ -in. dia. form, use any thin gauge wire

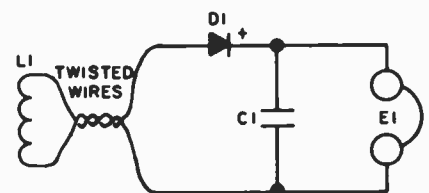

57 Miladaptor for VTVM

□ Less than \$2 worth of parts is all it takes to convert your VTVM into a DC millammeter. To use the Miladaptor you simply multiply the VTVM reading by X10, X100 or X1000 to obtain the DC current. For example, if the VTVM indicates 0.1 volt and S1 is set to X100, the current is 0.1 X100 or 10 milliamperes. If the VTVM indicates 0.25 volts and S1 is set to X1000, the current is 0.25 X 1000 or 250 milliamperes.

The circuit under test connects to binding posts P1 and P2; the VTVM connects to binding posts P3 and

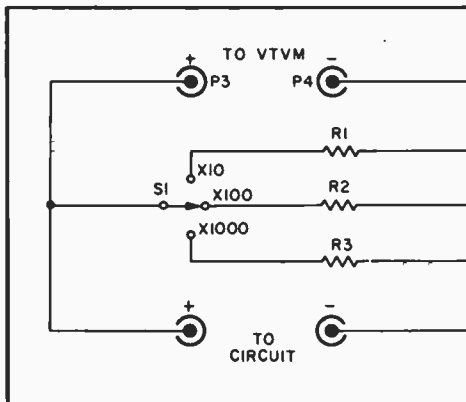

PARTS LIST FOR THE MILADAPTOR

- P1, P2, P3, P4—Insulated 5-way binding post
 R1—100-ohm, 1-watt, 5% resistor
 R2—10-ohm, 1-watt, 5% resistor
 R3—1-ohm, 1-watt, 5% resistor
 S1—rotary switch 3PST

P4. Switch S1 must be the make-before-break type. To avoid damage always start with S1 in the X1000

position and downrange until the VTVM indicates a convenient reading.

58 Super Sensitive FSM

□ A kilowatt transmitter may pin the needle of regular FSMs (field strength meters), but you need high sensitivity to get readings from low-power oscillators, flea power transmitters and CB walkie-talkies. This simple, amplified FSM has a sensitivity of 150 to 300 times that of ordinary models. It indicates full scale when other meters can't budge off the pin.

Dependable frequency range is approximately 3 to 30 MHz. A metal enclosure is recommended, with a stiff wire antenna about 6 in. long. For compactness, RFC should be a miniature 2.5-mH choke.

To operate the unit, sensitivity control R1 is adjusted for 1/3 to 3/4-scale reading. Avoid working too

PARTS LIST FOR SUPER SENSITIVE FSM

- B1—1.5-V AA-battery
 C1—0.001- μ F disc capacitor
 D1—1N60

- M1—0-1 mA DC meter
 Q1—npn transistor—RCA SK3020 or Radio Shack 276-2009
 R1—50,000-ohm potentiometer
 RFC—2.5-mH choke—J. W. Miller 6302

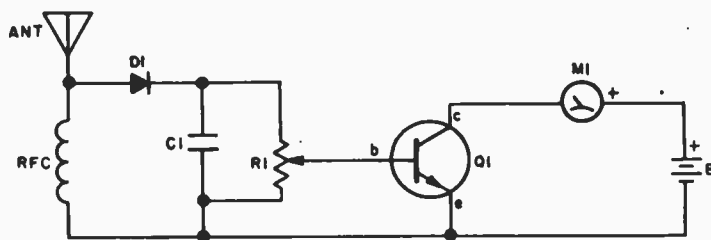

close to the top of the scale, since it can saturate transistor Q1, producing full-scale readings at all times. Back off on R1 as you make transmitter

adjustments to keep the needle at approximately half scale. Any high-gain npn small-signal transistor can be substituted for Q1.

59 Two-Dollar Signal Source

□ The average service shop has so much sophisticated test equipment it's easy to get the impression nothing can be fixed without a bench full of test gear. Yet much *sound* equipment—amplifiers, radios, receivers—can be serviced with a two-dollar signal injector like this one. Using ordinary general purpose transistors in a multivibrator circuit this signal injector produces a square waveform

output of approximately 700 Hz. Since the output is a square waveform, harmonics of the fundamental frequency are produced well into the RF spectrum, actually higher than 28 MHz. If you touch the output lead to a receiver's antenna input, RF amplifier, IF amplifier or audio amplifier (the ground lead will be needed for audio injection) you'll hear the tone in the speaker. If you

work backwards from the speaker the trouble is in the circuit at the point where you lose the tone.

Just about any small-signal NPN transistor can be used for Q1 and Q2. The battery can be an AA penlight cell. For maximum convenience the entire project can be assembled in a Keystone probe, or a small plastic pill box.

Correct troubleshooting procedure

using a signal injector calls for starting at the working end of a set and progressing, stage-by-stage, toward

the other, non-working end. For example, if a set produces circuit noise (hum, hiss, etc.) at a low level, but

no music or talk, you'd inject the signal at the input to the volume control (beginning at the audio stage(s).

PARTS LIST FOR TWO-DOLLAR SIGNAL SOURCE

- Resistors ½- or ¼-watt, 10%
- R1, R4—10,000-ohms
- R2, R3—100,000-ohms
- C1, C2—0.01- μ F, 6-VDC or higher
- C3—0.01- μ F, 500-VDC or higher (ceramic disc suggested)
- Q1, Q2—NPN transistor, 2N2222 (Radio Shack 276-2009 or equiv.)
- B1—1.5-volt battery
- S1—Switch SPST

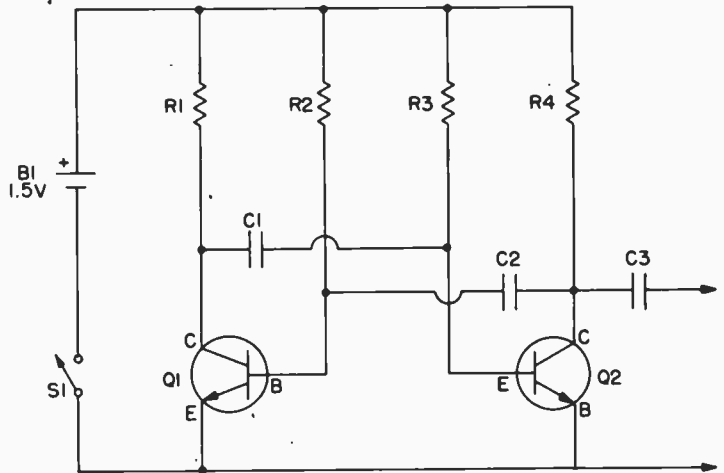

60 Easy Field Strength Meter

High sensitivity without amplification is obtained when a field strength meter (FSM) is tuned to its operating frequency. With a poly-type miniature capacitor for C1, the FSM can be built in a pocket-size cabinet.

Tuning range is from 1.5 to 144 MHz, depending on the choice of coil L1. The coil can use phone tip jacks for a plug-in connection for band changing. Consult any coil table for L1's winding data since coil construction depends on the type of

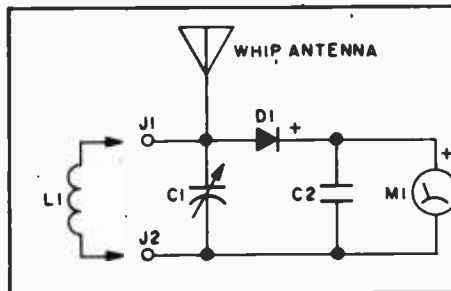

PARTS LIST FOR EASY FIELD STRENGTH METER

- C1—365-pF variable capacitor
- C2—.005- μ F disc capacitor
- D1—1N60 diode
- J1, J2—Phone tip jack
- L1—Coil (see text)
- M1—0-1 mA DC meter

wire and frequency.

Even greater sensitivity is obtained if a more sensitive meter is used.

A 50- μ A meter, M1, provides maximum sensitivity combined with reasonably rugged construction.

61 Budget Scope Calibrator

You can make accurate voltage measurements with your oscilloscope if you calibrate the vertical input with a Scope Calibrator.

When the top of zener diode D1 goes negative it conducts and voltage across the diode is essentially zero. When the voltage at the top of the

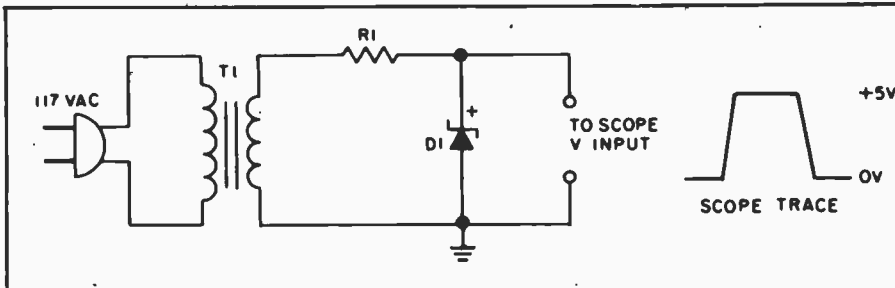

zener goes positive, it builds until it reaches 10 V. At that point the diode conducts, dropping five volts across D1. The result is a square wave which varies from zero to 10 V, as shown.

The scope's vertical input is con-

nected across the diode and the vertical attenuator control is adjusted so the square wave exactly fills one vertical division. This provides a calibration of 10 V peak-to-peak per division. The scope's vertical attenuator

then provides multiples of the calibration such as 1 V/div., 10 V/div., etc. Since calibrator output varies from zero volts it may be necessary to adjust the vertical centering when the scope's DC input is used.

PARTS LIST FOR BUDGET SCOPE CALIBRATOR

- D1—10V, 0.4-watt Zener diode—HEP-101
- R1—270-ohm, ½-watt resistor
- T1—117 to 12.6 VAC filament transformer
- C1, C3—0.01- μ F, 25-VDC capacitor
- C2—0.002- μ F, 25-VDC capacitor
- Q1—HEP-720 npn transistor (Radio Shack 276-2015)
- R1—100,000-ohm, ½-watt resistor
- R2—1000-ohm, ½-watt resistor
- Xtal—100-kHz crystal

62 Time Base Reference

□ Operating on exactly 100 kHz, the Scope Calibrator provides a reference for calibrating the variable time base oscillator of general purpose scopes. If the scope is set, for example, so one cycle of the signal fills

exactly 10 graticule divisions, each division represents 1 MHz, or 1 microsecond. If the scope is adjusted for 10 cycles on 10 graticule divisions, or 1 cycle per division, each division represents 100 kHz or 10

microseconds. Now if the scope's time base oscillator is sufficiently stable so it doesn't drift to far off, you can make precise measurements of an unknown pulse width, length and frequency.

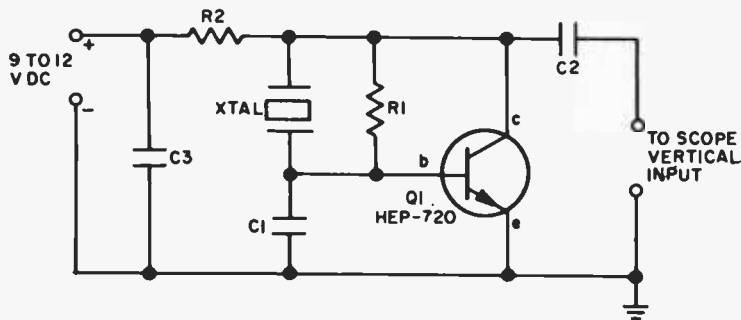

PARTS LIST FOR TIME BASE REFERENCE

C1, C3—0.01- μ F, 25-VDC capacitor
 C2—0.002- μ F, 25-VDC capacitor
 Q1—HEP-720 npn transistor
 R1—100,000-ohm, 1/2-watt resistor
 R2—1000-ohm, 1/2-watt resistor
 Xtal—100-kHz crystal

63 Doorknob Security Alarm

□ Here's security for the traveler. Just connect this alarm to the doorknob of your motel room and a loud buzzer will sound if anyone touches the doorknob.

PARTS LIST FOR DOORKNOB SECURITY ALARM

B1—6-volt battery, Burgess Z4 or equiv.
 BP1—Binding post
 BU1—6-volt buzzer
 C1, C2—0.05- μ F disc capacitor, 25 VDC or better
 C3—47-pF silver mica capacitor (Allied Electronics 782-0860).
 C4—300-pF trimmer capacitor
 C5—0.05- μ F, 25 VDC capacitor
 C6—50- μ F electrolytic capacitor, 25 VDC or better
 D1, D2—Diode, 1N60
 D3—Diode, 1N914

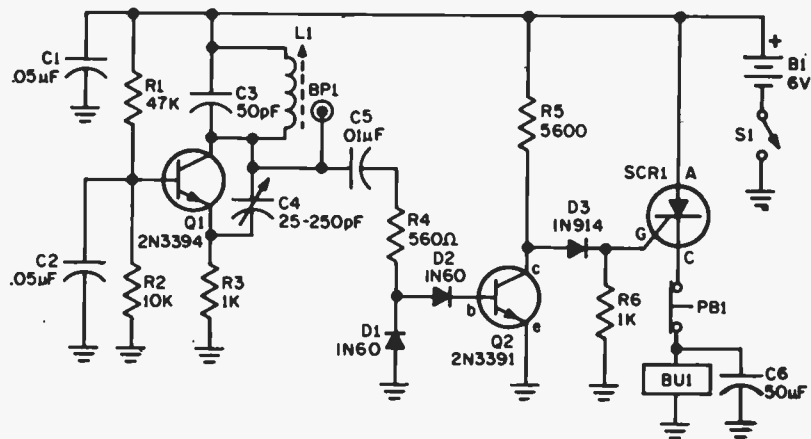

L1—15- μ H adjustable RF coil (Miller 4205, or equiv.)
 PB1—Pushbutton switch (reset)
 Q1—2N3394
 Q2—2N3391
 R1—47,000-ohm, 1/2-watt resistor
 R2—10,000-ohm, 1/2-watt resistor

R3, R6—1000-ohm, 1/2-watt resistor
 R4—560-ohm, 1/2-watt resistor
 R5—5600-ohm, 1/2-watt resistor
 S1—Switch, spst (on-off)
 SCR1—800-mA/30-V silicon controlled rectifier, HEP R1001

Transistor circuit Q1 is an oscillator with a connection through binding post BP1 to the doorknob. As long as Q1 oscillates, its rectified output is applied to Q2 which holds the SCR1 gate almost at ground potential. When someone touches the doorknob, hand capacitance "kills" the oscillator, thereby removing that cut-

off (holding) bias from the SCR1 gate; the SCR conducts and sounds alarm buzzer BU1. The alarm can only be turned off by opening reset switch PB1.

The alarm should be assembled in a small metal cabinet with insulated binding post BP1 at the top. A small wire loop attached to BP1 secures the

alarm to the doorknob—the alarm actually hangs on the knob. To adjust, carefully set C4 in small increments until touching your finger to BP1 causes the buzzer to sound. If C4 is overadjusted, hand capacitance will not "kill" the oscillator. Best operation is obtained if the door is made of wood.

64 Foil-A-Burglar Alarm

□ This professional type burglar alarm can be used to protect windows or glass areas by using window foil that "breaks" a circuit as the glass is broken. It's an alarm that is triggered when the protective circuit is *opened*. All protective door and window circuits must be *normally closed* and series connected so that an opening

of any protective device will trigger the alarm. Once the alarm is triggered it can be turned off only by opening master switch S1.

The recommended power supply is an AC powered 6 VDC source or a lantern battery; standby current is about 100 μ A. To adjust, connect a voltmeter (10 VDC range) across re-

sistor R1, open the protective circuit and adjust potentiometer R2 so the meter indicates a voltage rising towards 1 volt. The alarm bell should ring before 1 volt is reached on the meter. If it does not, there is a wiring error. Finally, set R2 for the 1 volt meter reading, remove the meter and restore the protective circuit.

PARTS LIST FOR FOIL-A-BURGLAR ALARM

- C1—47- μ F, 12-VDC electrolytic capacitor
- Q1—NPN transistor, HEP 53 (Radio Shack 276-2009)
- R1—1000-ohm, 1/2-watt resistor
- R2—500,000-ohm, pot (Calectro B1-687)
- S1—Spst switch
- SCR1—Silicon controlled rectifier rated 12 PIV or higher HEP R-1101
- V1—6 VDC alarm bell (Audiotex 30-9100)

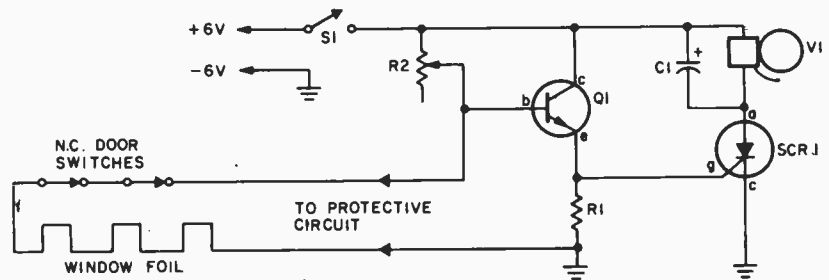

65 Open Circuit Burglar Alarm

□ This simple electronic latch-up alarm circuit handles normally open protective devices such as concealed floor-mat switches. All protective devices are connected in parallel and the alarm is tripped as soon as any of the devices are closed. There is no standby current and a battery power source will last its shelf life. Either a line powered 6VDC supply or a 6V lantern battery is suggested. Once the alarm is tripped it can only be turned off by opening the master switch S1.

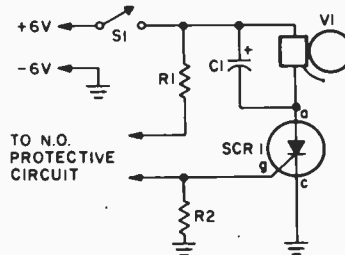

PARTS LIST FOR OPEN CIRCUIT ALARM

- C1—50- μ F, 12 VDC electrolytic capacitor
- R1—4700-ohm, 1/2-watt resistor
- R2—1000-ohm, 1/2-watt resistor
- S1—Spst switch
- SCR1—Silicon controlled rectifier, rated 12 PIV or higher (HEP R-1220 or equiv.)
- V1—6 VDC alarm bell (Audiotex 30-9100)

66 Auto Ignition Maze

□ Install a combination lock on your car's dashboard and a thief would have a better chance playing Russian roulette.

Switches S1 through S5 are spdt rather than spst only to keep all external switch markings the same.

Tracing the circuit will show that only if switches S2 and S4 are down is the siren disabled. The siren sounds if any other switch is down or if S2

or S4 is up when the ignition is turned on. A simple wiring change lets you set any combination.

The switches can be "sporty" auto accessory switches sold individually or in switch banks such as G.C. 35-916. Provide labels such as "Carburetor Heater," "Window Washer," etc. and no one will know the car is wired for "sound."

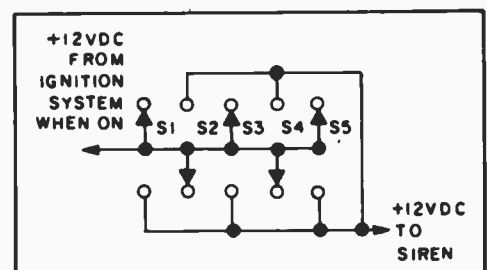

67 Latching Burglar Alarm

□ Open a fancy commercial burglar alarm and all you'll find inside is this ordinary relay latching circuit.

The input terminals are connected to parallel-wired normally open (N.O.) magnetic switches, or wire-type security switches stretched across a window that *close* a bell contact circuit when the wire is pushed or pulled.

When a security switch closes the series battery circuit, relay K1 pulls in. One set of contacts closes the alarm bell circuit, while the second set "latches" the battery circuit. Even if the security switches are opened, the alarm remains on. To disable the alarm, or for reset, install a concealed switch in series with one battery lead.

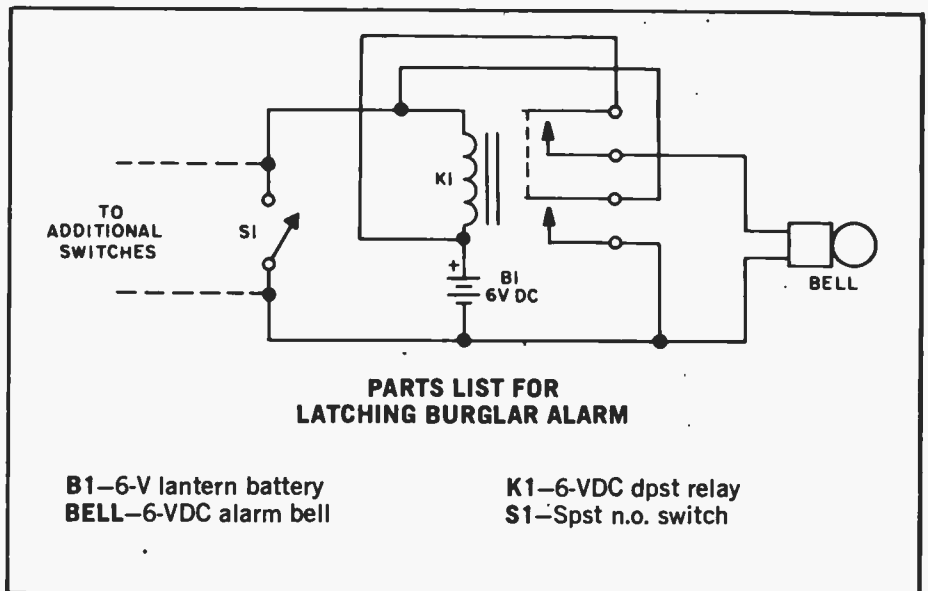

68 Power Failure Alarm

□ Never fear again that a power failure will knock out your electric alarm clock. The instant the juice fails, the Power Failure Alarm's raucous buzz let's you know about it, even in the wee hours of the morning.

To keep current consumption (and operating costs) at rock bottom, a very sensitive relay is used for K1. As long as AC power is supplied, K1 is activated and the buzzer contacts are held open. When power fails, K1's

contact springs back, completing the battery connection to the buzzer.

K1 is a "model radio-control" type relay with a pull-in current of approx. 1.5 to 3 mA.

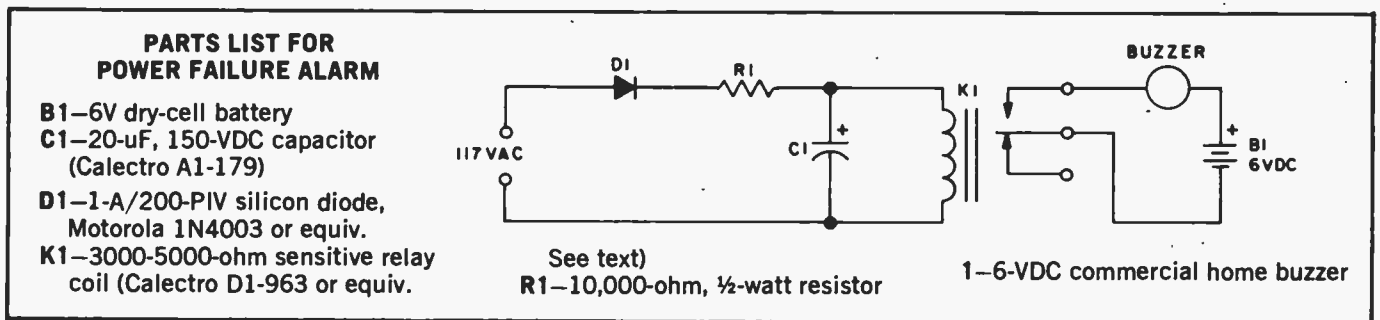

69 Easy Auto Theft Alarm

□ A single fender-mounted key switch is all that's needed to turn your car's horn and courtesy lights into a burglar or theft alarm! Simply install key switch S1 on the fender, connect one terminal to the horn relay and the other to the courtesy-light door-switch wiring, as shown by the dotted lines.

When S1 is *on*, anyone entering a car door equipped with a courtesy-light switch will automatically sound

the car's horn. The sudden blast of the horn is usually enough to frighten off a potential burglar. If all the car doors are not equipped with switches you can easily install them; switches are available from local auto supply stores.

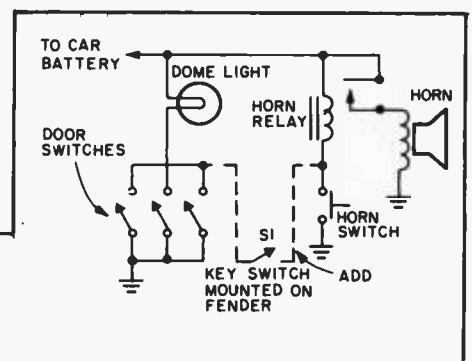

70 Better Scope Calibrator

PARTS LIST FOR BETTER SCOPE CALIBRATOR

- D1, D2—5-V, ¼-watt Zener diode
- R1—270-ohm, ½-watt resistor

□ Back-to-back zener diodes provide a scope calibrator with a zero reference output. Whether the calibration voltage is fed to a scope's AC or DC

input, the baseline will not have to be readjusted.

When the top of D1 goes positive D1 conducts current through to the D2 cathode. The voltage across D2 builds until 5 V is reached and the output waveform is 5 V positive. The reverse action takes place when the top of D1 goes negative, providing an output waveform of 5 V negative. The total result is a 10 V peak-to-peak square wave to calibrate the scope face.

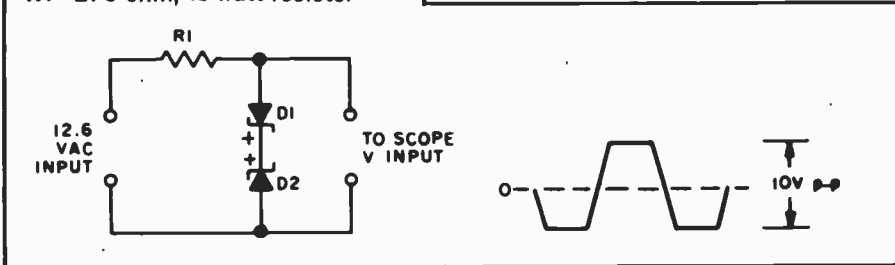

71 Appliance Tester

□ A simple circuit consisting of a 50-watt lamp, fuse and power outlet is all that's needed to check out appliances such as toasters and electric coffee pots.

To check for *opens*, first plug the tester into a live outlet. Next, connect the test leads to the appliance's power cord; if the lamp lights, the circuit is good (not open). Because the appliance is in series with the lamp, the lamp may not light to full brilliance. You are only interested in whether the lamp lights at all—not the level of brilliance.

If you suspect there is a short from

PARTS LIST FOR APPLIANCE TESTER

- F1—Fuse to match load
- I1—50-watt lamp
- PL1—AC receptacle

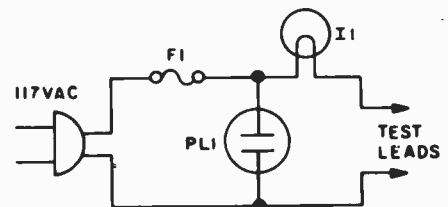

the appliance's motor or heating coil to the appliance frame which can cause a shock hazard, connect one test lead to the appliance frame and connect the other test lead first to one prong of the appliance's plug and then to the other prong. If the lamp lights with either connection there is a short

to the frame. If the lamp fails to light at all, the appliance frame is safe.

After the repair is made, try out the appliance by using the fused power outlet, PL1. This way, if the appliance is still defective it will blow fuse F1 rather than a fuse in the basement.

72 Light Activated Power Control

□ Heavy direct current or DC power is easily controlled without the use of massive power switches and wiring by using a LASCR (light activated silicon controlled rectifier) as an interface between the control and controlled circuits. The LASCR is similar to an SCR except that the gate is tripped by light rather than voltage/current.

The triplamp can be any ordinary flashlight bulb powered by two D cells. When the lamp is turned on the LASCR gate is closed, causing current to flow through the load and the LASCR anode (a) cathode (c) cir-

cuit.

A suitable LASCR is one from GE's L8B series. Use one with the appropriate PIV rating. Inexpensive LASCRs are occasionally available from "surplus dealers", though you must make certain the "surplus" unit has the required PIV rating.

PARTS LIST FOR LIGHT POWER CONTROL

- I1—Flashlight bulb or pilot lamp (see text)
- Q1—Light-activated-silicon-controlled rectifier (LASCR)
- R1—47,000-ohm, ½-watt resistor

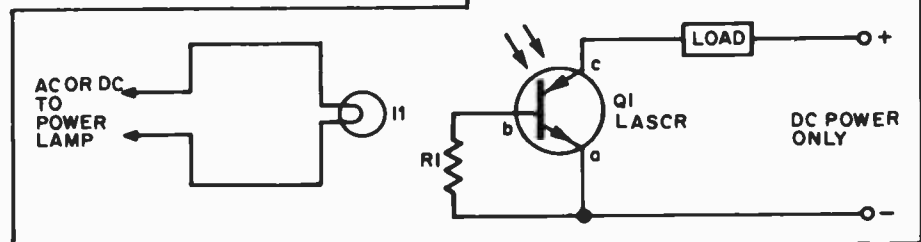

73 Speaker-A-Mike Preamp

□ A speaker can often serve as a microphone in intercoms, "one-way telephones" or as an emergency microphone. All the speaker needs is amplification to raise "voice power" output to normal mike level.

A small speaker-mike preamp can easily be thrown together with junk

box parts and just about any general purpose transistor with a beta of 30 to about 150. While a pnp transistor is shown, an npn type can be substituted if the battery and C1's polarity are reversed. No other changes are needed.

Q1 is a common base amplifier

providing a low impedance input to match a low impedance speaker of 3.2, 4, 6-8, or 16 ohms. The collector output is medium impedance and the .47- μ F capacitor at C2 allows the preamp to work into loads of 7000 ohms or higher.

PARTS LIST FOR SPEAKER-A-MIKE PREAMP

B1—9-V battery

C1—4.7- μ F, 25-VDC electrolytic capacitor

C2—0.47- μ F, 10-VDC capacitor

Q1—RCA SK 3004 (Radio Shack 276-2005)

R1—270,000-ohm, $\frac{1}{2}$ -watt resistor

R2—27,000-ohm, $\frac{1}{2}$ -watt resistor

S1—Spst switch

Spkr—Any PM speaker, 4-10-ohms

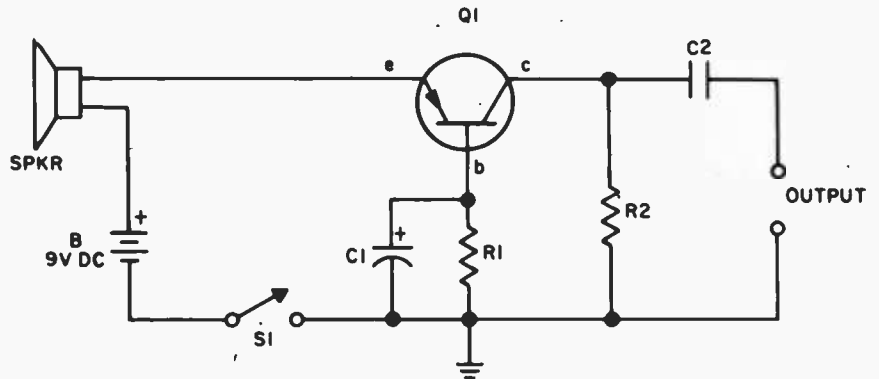

74 Basic Color Organ

□ This simple color organ is certain to keep your party from becoming a drag. Connected to your hi-fi amplifier's speaker output (across the speaker terminals) it will throb in time to the music. Paint the bulb red or deep blue and your party room will take on the atmosphere of a rock club.

Transformer T1 can be any matching transistor type in the range of 500/500 to 2500/2500 ohms. Note that none of the connections from SCR1 or its components are connected to ground. For safety's sake, you must keep the 117-volt line voltage from the amplifier connections—that's the reason for T1. To adjust, set po-

tentiometer R1 "off" and adjust the amplifier volume control for a normal listening level. Then adjust R1 until lamp I1 starts to throb in step with the beat.

PARTS LIST FOR BASIC COLOR ORGAN

I1—117V lamp, not to exceed 40 watts.

R1—Potentiometer, 500 to 5000 ohms

SCR1—Silicon Controlled Rectifier, HEP R1218

T1—Transistor output transformer, see text

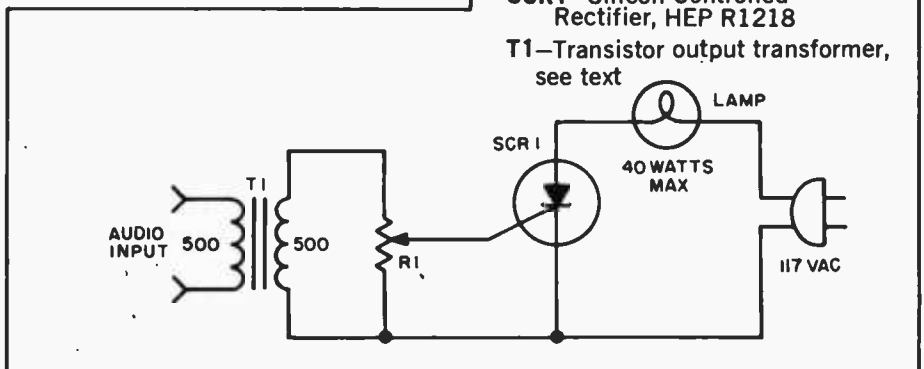

75 Lo-Parts Treasure Locator

□ You won't find Long John Silver's buried treasure but you will have lots of fun finding bottle caps and uneaten sandwiches at the beach; maybe even some quarters and dimes.

This treasure locator keeps costs down by using a transistor radio as the detector. The unit is assembled on a perf-board, with rigid component mounting a must. It is strapped

to a broom handle close to the bottom where the search head is mounted. A transistor radio is mounted near the top of the handle.

With the radio tuned to a "weak

station," Capacitor C1 is adjusted so the locator oscillator "beats" against the received signal, producing a whistle in the receiver. When the search head passes over buried metal, the metal changes the inductance of L1, thereby changing the locator oscillator's frequency and changing the "beat tone" in the radio.

The search coil consists of 18 turns of #22 enameled wire *scramble wound* (which means don't be neat) on a 4-in. diameter form, which can be a cardboard tube or a wood puck or even plastic—anything but metal. After the coil is wound and checked for proper operation, saturate the coil with *coil dope* or G.E.'s RTV

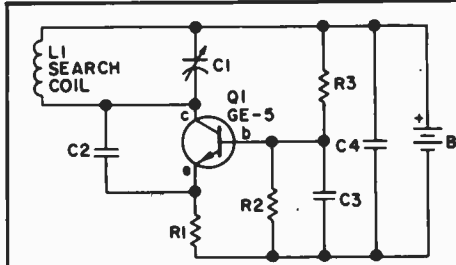

**PARTS LIST FOR
LO-PARTS TREASURE LOCATOR**

B1—9-VDC transistor battery
C1—365-pF trimmer or variable capacitor

C2—100-pF, 100-V silver mica capacitor (Allied Electronics 782R0818)
C3—0.05-uF, disc capacitor
C4—4.7- or 5-uF, 12-V electrolytic capacitor
L1—Search coil consisting of 18 turns of #22 enamel wire scramble wound on 4-in. diameter form
Q1—RCA SK3011 npn transistor or equiv.
R1—680-ohm, ½-watt resistor
R2—10,000-ohm, ½-watt resistor
R3—47,000-ohm, ½-watt resistor

adhesive. If a single loop of the coil is not firmly cemented the unit will

be unstable.

76 Photo Print Meter

□ Every print a good print! That's what you get with the photo print meter.

Meter M1 can be just about anything up to 0-1 DC mA. But if you prefer low light levels and long exposures, install a sensitive meter of 500 μ A or less.

When light from the enlarger falls on the solar cell (PC1), a voltage is generated that is in proportion to the amount of light. Sensitivity control R1 allows the user to set the meter indication to a convenient value.

To use the meter, first make a good normal print in your normal manner from a No. 2 or No. 3 nega-

tive. Then, do not disturb the enlarger setting, but integrate the light by placing a diffusing disc or opal glass under the lens. Place the solar cell on the easel and adjust R1 for a convenient meter reading, say, full scale. The meter is now calibrated.

When using it, focus the enlarger, use the diffuser, and adjust the lens diaphragm until you get the reference meter reading. Then use the exposure time previously found for the calibration print. Suggested reading: Ilford Manual of Photography, obtainable from any photo store. Also, check Kodak publications available at the same place.

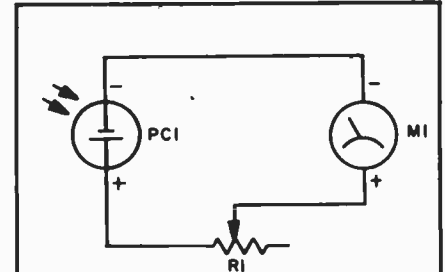

**PARTS LIST FOR
PHOTO PRINT METER**

M1—100, 250, or 500- μ A DC meter
PC1—Solar cell (Calectro J4-801)
R1—5000-ohm potentiometer linear taper

77 Action Freeze Photo Trip

□ You, too, can take strobe-flash pictures the instant a pin pricks a balloon, a hammer breaks a lamp bulb or a bullet leaves a gun. You'll

need a mini-amp—one of those transistor amplifier modules of 1-watt rating or less. *It must have an output transformer.* Don't use an "OTL" (no transformer) amplifier. The amplifier is terminated with a resistor on its highest output impedance, preferably 16 ohms. Make certain the connec-

tions to the strobe flash sync terminals are correctly polarized.

Darken the room lights, open the camera shutter and break a lamp bulb with a hammer. The sound of the hammer striking the lamp will trigger the flash, and the picture will have been taken at that instant.

**PARTS LIST FOR
ACTION FREEZE PHOTO TRIP**

D1—HEP-154 silicon rectifier
R1—5000-ohm potentiometer
R2—2700-ohm, ½-watt resistor
SCR1—Calectro K4-584 silicon-controlled rectifier
MIC.—Ceramic microphone

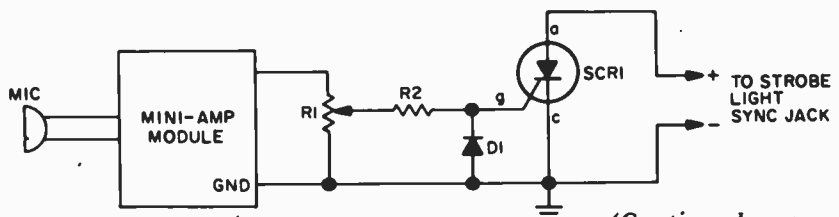

(Continued on page 54)



CB NEW PRODUCTS



101 Electronic Projects looks at some of the newest transceivers, antennas and accessories for you to use in CB contacts this year!

CB/RF Generator

A new RF Generator, the Model 256 by Hickok, has features important to CB service technicians. One of the 256's five bands covers CB channels 1 through 40 on an expanded tuning range for easy, precise channel selection. Frequencies of 100 kHz through 16 MHz are covered on the other four bands to satisfy all IF requirements including 455 kHz and 10.7 MHz. A calibrated/attenuated output control provides RF signal output of 100,000 uV down to less than 1 uV for receiver sensitivity checks. The attenuated output is variable in 20-dB steps and by a continuously-variable 20-dB control calibrated in

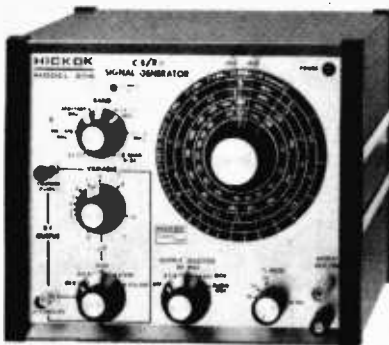

CIRCLE 50 ON READER SERVICE COUPON

microvolts. Internal modulation at a frequency of 1 kHz is variable from 0 to 100 percent, calibrated at 30 percent. Provision is also made for use of external modulation. When the audio output function is selected, a 1 kHz audio signal is available at these same front-panel out/in jacks. The Hickok Model 256 CB/RF Generator is available through Hickok distributors. Suggested retail price is \$199.00. For further information on the Hickok Model 256 CB/RF Generator or other Hickok CommLine equipment, write to Hickok Electrical Instrument Company, 10514 Dupont Avenue, Cleveland, OH 44108.

CB Slide Mount

A new Sparkomatic Citizens Band Slide Mount developed exclusively for use with CB transceivers sells for approximately \$14.95. The LM-



CIRCLE 63 ON READER SERVICE COUPON

500 is designed for easy removability to prevent theft. The special coaxial cable "quick disconnect" connector prevents RF loss and the unique spring loaded power contacts eliminate power loss under rough road conditions. In addition, the contacts and quick disconnect RF plug are silver plated for long operating life and low losses. The usual messy long wires are eliminated by using printed circuit techniques and connecting fuse on contact assembly. Unlike a large number of unsightly and unnecessary connections on other mounts, the LM-500 has only the two required connections for CB operation—the antenna cable and power line. Get all the facts by writing to Sparkomatic Corporation, Milford, PA 18337.

CB Maximum Security

A locked, 18-gauge sheet steel box that completely encloses and conceals CB radios, yet allows easy access for normal operation, is now available from CB Saver. The device bolts permanently to the vehicle's chassis, dash or floor with a special bracket—and mounting hardware is inaccessible after installation. The radio is held inside by heat-treated springs, with entry points provided for power, microphone and antenna leads. A double-locking door closes over



CIRCLE 48 ON READER SERVICE COUPON

the face of the box, fully concealing the radio when not in use. Unlocked, the door swings down on a heavy piano hinge, exposing the

radio. Additional features include bonded vinyl covering and rounded corners. CB Saver, only 8 by 3 by 12-in. in size, accepts 98 percent of CB radios on the market, including the new 40-channel models, and is also adaptable to marine radios and auto stereo tape decks. Suggested retail price of the CB Saver is \$49.95. Mounting hardware and instructions for easy installation are included. Get all the facts by writing to CB Saver, 800 South Claremont Street, San Mateo, CA 94402.

Takes Two to CB

Designed especially for trucks, motor homes and other recreational vehicles, and to work on all 40 channels, Avanti's AV-529 CB antenna system increases performance approximately 25 percent over a single roof-mounted antenna, and minimizes the problem of a skewed or shifted radiation pattern. The system consists of two 4-ft. fiberglass Avanti Racer antennas in co-

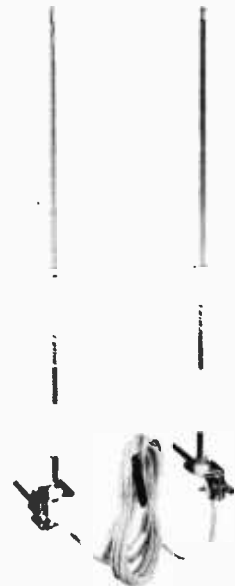

CIRCLE 64 ON READER SERVICE COUPON

phased arrangement, and mounted to outside rear view mirrors. The mounting assembly fits most mirror bracket arrangements including west coast types. The co-phasing harness, completely factory tested to assure maximum performance, connects quickly and easily to the mirror mounts. Priced at \$53.95. Get the info direct from Avanti Research & Development, Inc., 340 Stewart Avenue, Addison, IL 60101.

"Under Cover" CB Antennas

Channel Master's 40-channel coil-loaded whip antennas can be conveniently flipped down and hidden in the automobile trunk when not in use. By not signalling the presence of CB equipment, the new Under Cover antennas sharply reduce the danger of theft, without sacrificing performance. Base-loaded and center-loaded models are available, mounted on a specially designed,

CB NEW PRODUCTS



CIRCLE 52 ON READER SERVICE COUPON

heavy Under Cover bracket that is fastened to the lip of the trunk. The two-way bracket enables the CBER to mount the antenna in a perfectly vertical position, regardless of the slope of the car's rear deck, and also allows the antenna to be folded down into the trunk, completely out of sight. No tell-tale sign is visible, not even a trace of hardware. Within the trunk, the bracket keeps the antenna suspended horizontally, so that it does not interfere with the storage of luggage or baggage. The chrome-plated bracket serves as a self-grounding base. It fits most domestic and foreign cars, and may be purchased separately, for use with the CBER's existing antenna. The models in the line include single and dual base- and center-load antennas, as well as the bracket only. For more information and prices, contact Channel Master Div. of Avnet, Inc., Ellenville, NY 12428.

Base Station Antenna Mounting Kit

Antenna Specialists announces their new M-481 base station antenna mounting kit. Each kit contains everything needed to side mount an A/S antenna on a house. Included are: a 10 ft. galvanized steel mast (two pieces), 50 ft., of RG 8/U coaxial cable, two PL-259 connectors



CIRCLE 60 ON READER SERVICE COUPON

(one attached each end of the cable), two house side mounts and three cable standoffs. And all this at the price of \$39.95. For more information on this mounting kit and A/S base station antennas, write to The Antenna Specialists Co., 12435 Euclid Avenue, Cleveland, OH 44106.

Walkie-Talkie With Remote Mike

Radio Shack introduces a new Citizens Band walkie-talkie with a jack for use with push-to-talk microphone. The Realistic TRC-200 includes a built-in speaker and separate electret mike for conventional hand-held operation. The remote mike feature makes it possible to set the unit down or fasten it to a vehicle, backpack, or elsewhere, out of the way, and still operate without having to reach the unit itself or use the built-in transmit button on the walkie-talkie case. A Hi/Lo power switch selects the full five-watt input power or



CIRCLE 54 ON READER SERVICE COUPON

three watts for shorter range communications and longer battery life. Features include top-mounted volume, squelch and channel selector controls, battery/RF power meter, center-loaded telescoping antenna and jacks for an external speaker, 12 VDC power source, antenna and battery charger. The TRC-200 is supplied with channel 14 crystals and has provisions for five more channels. Priced at \$99.95, complete with carry case and eight "AA" cells. Optional push-to-talk mike, \$11.95. Available from Radio Shack stores and dealers, nationwide.

CB Power Supplies

Designed to operate CB radios, stereos, tape decks and other auto accessories, the Staco CB power supplies feature solid state reliability, integrated circuit regulation control, full 13.8 VDC output, automatic dual overload and short circuit protection, no background hum and 90 day factory warranty. Staco's 4-amp Model RPS-4 (\$42.95) and 6-amp Model RRS-6 (\$49.95) Regulated Power Supplies give maximum performance from mobile CB radios and will trickle



CIRCLE 65 ON READER SERVICE COUPON

charge 12-volt car batteries. These heavy duty power supplies are dual overload and short

circuit protected automatically by a unique current fold back circuit and internal circuit breaker. Model PS-4 is a 4-amp Deluxe Filtered Power Supply, having automatic overload and short circuit protection. Designed to power 8-track tape decks, stereos, CB radios and similar equipment. All Staco Heavy Duty Power Supplies come complete with an input power cord, switch, pilot light and operating instructions. Output connections are made at the terminal board located on the rear panel. For more information, write to STACO, Inc., 2240 East Third Street, Dayton, Ohio 45403.

New Fiberglass Antenna Line

Turner announces the new "Yellow Jackets"—the fiberglass antennas with the micro tunable stingers. Turner's new top loaded antennas allow precise tuning by simply loosening a nut at the top of the whip, adjusting the tip for minimum VSWR and then retightening the nut. Sixteen new models, made of the highest quality composition fiberglass, are offered. All have a high

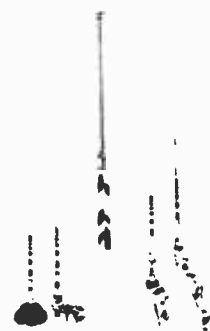

CIRCLE 56 ON READER SERVICE COUPON

power rating of over 100 watts. Antennas are equipped with standard 3/8-24 threads. Turner's economically-priced "Yellow Jackets" are designed for use with the new 40-channel CB transceivers. Priced to sell from \$17.50 to \$45.00. For complete information, write to Turner Division, Conrac Corporation, 716 Oakland Road N.E., Cedar Rapids, Iowa 52402.

Twin-Scale Meter

Mura's Model CBM-30 CB meter is a twin-meter unit. There are separate power and SWR scales permitting the CBER to simultaneously monitor RF output power and VSWR. The meters are sensitive d'Arsonval types with an SWR scale that has a range extending from 1:1 to 10:1 and can measure up to 100 watts.



CIRCLE 67 ON READER SERVICE COUPON

No switching is required and both meter pointers are controlled by a continuously variable knob on the front panel. Calibration marks permit the user to return to any previously determined setting. Priced at \$46.50. For further information, write to Mura Corporation, Westbury, NY 11590.

78 Remote Flash Trigger

□ Even if you spend \$18 or \$20 for a super-duper professional remote flash tripper, you'll get little more than this two-component circuit. Price is important if the results are equal.

Transistor Q1 is a light-activated silicon-controlled rectifier (LASCR). The gate is tripped by light entering a small lens built into the top cap.

To operate, provide a 6-in. length of stiff wire for the anode and cathode connections and terminate the wires in a polarized power plug that match-

es the sync terminals on your electronic flashgun (strobe light). Make certain the anode lead connects to the *positive* sync terminal.

When using the device, bend the connecting wires so the LASCR lens faces the main flash. This will fire the remote unit.

No reset switch is needed. Voltage at the flash's sync terminals falls below the LASCR's holding voltage when the flash is fired, thereby turning off the LASCR.

- PARTS LIST FOR REMOTE FLASH TRIGGER**
Q1—200-V light-activated silicon-controlled rectifier (LASCR)
R1—47,000-ohm, ½-watt resistor

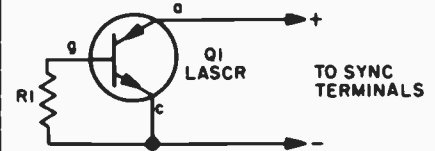

79 Flash Tester

□ The way film and flashbulb prices are going these days, if your flash fails to fire you're stuck with almost half a buck in wasted polaroid film, and if you fire a flash to check the flashgun battery you've just burned up at least 25-cents worth of flash. But worse, if the flash fails to fire you might have missed the picture of a lifetime.

You can't check a flash battery with a voltmeter because the meter doesn't apply the heavy surge current needed by the flashbulb, and just about any fully dead battery that

isn't leaking acid will check okay when tested without load.

This little flash tester you can probably build from junk-box parts will give you a quick load-check on flashgun batteries. T1 can be any 6.3-volt filament transformer rated from 300-mA up. NL-1 is just about any neon lamp of the NE-2 or NE-86 variety. Solder T1's terminals to those of a used flashbulb or flashcube.

To check the battery, just plug in the flash tester and trip the camera shutter (cover the lens if the camera has film). Lamp NL-1 will flash if the

battery is okay (T1 requires a high inrush current, as does the flashbulb).

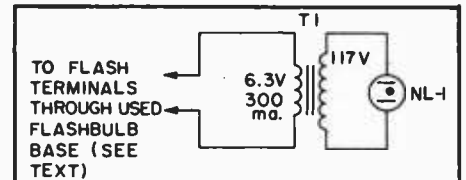

- PARTS LIST FOR FLASH TESTER**
T1—6.3-volt filament transformer
NL-1—Neon lamp, see text
Misc.—Used flashbulb base.

80 Variable Flood Lighting

□ All the flexibility of a professional photo studio's variable lighting can be yours with this 500-watt lamp dimmer.

Triac Q1 must be connected to a large heat sink. The entire unit is assembled in a metal cabinet with Q1

epoxy-cemented to the cabinet for heat dissipation.

Fusing must be employed. Otherwise, the surge current when 500-watt photo lamps burn out will instantly destroy Q1. Connect an 8AG (fast-action) 5-ampere fuse in series with

the lamp or any other fuse of equal action, or faster. In this circuit 3AG fuses cannot be used. Potentiometer R2 will adjust the lamp's intensity from full off to essentially 100% full on.

PARTS LIST FOR VARIABLE FLOOD LIGHTING

- C1, C2**—0.01-μF, 300-VDC capacitor
D1—HEP-311 diode
F1—Fuse, type 8AG, 5A
Q1—Triac, HEP R1723, 8A/200V
R1—1000-ohm, ½-watt resistor
R2—100,000-ohm linear taper potentiometer
R3—15,000-ohm, ½-watt resistor

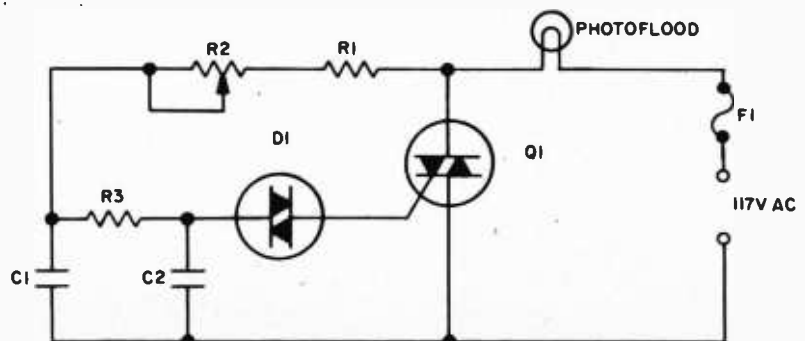

81 Angler's Bite Booster

Click-click might not sound like much to you but to a fish it's the dinner bell. That's the lure of this electronic circuit. Shove the whole works in a watertight container, lower it over the side, and wait for the fish to hit the hooks.

For proper operation T1 must be subminiature type about half as large as your thumb. E1 must be a crystal headphone.

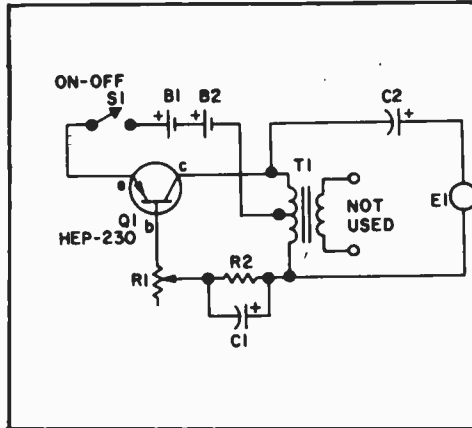

PARTS LIST FOR ANGLER'S BITE BOOSTER

- B1, B2—1.5-V AAA battery
- C1, C2—50- μ F, 12-VDC electrolytic capacitor
- E1—Crystal earphone
- Q1—Motorola HEP-230 pnp transistor
- R1—5000-ohm pot
- R2—27,000-ohm, 1/4-watt resistor
- S1—Spst switch, part of R1
- T1—Subminiature transistor output transformer; 500-ohm center tapped primary to 8-ohm secondary

82 Commercial Killer

A flashlight beam stabs out—the irritating TV commercial for under-arm deodorant vanishes. Moments later, when the program returns, the flashlight beam stabs out again. The sound snaps back on. Between the flashlight and TV speaker circuit

is the light-controlled switch.

When a beam of light strikes the photocell, the voltage across neon lamp NE-1 rises sharply. When conduction voltage is reached NE-1 turns on and fires the SCR. K1 is an impulse relay whose contacts stay in

position even after coil current is removed. So the first impulse opens K1's contacts, the second impulse closes them, etc. To prevent ambient light from tripping the photocell, it should be recessed at least an inch inside a metal or cardboard tube.

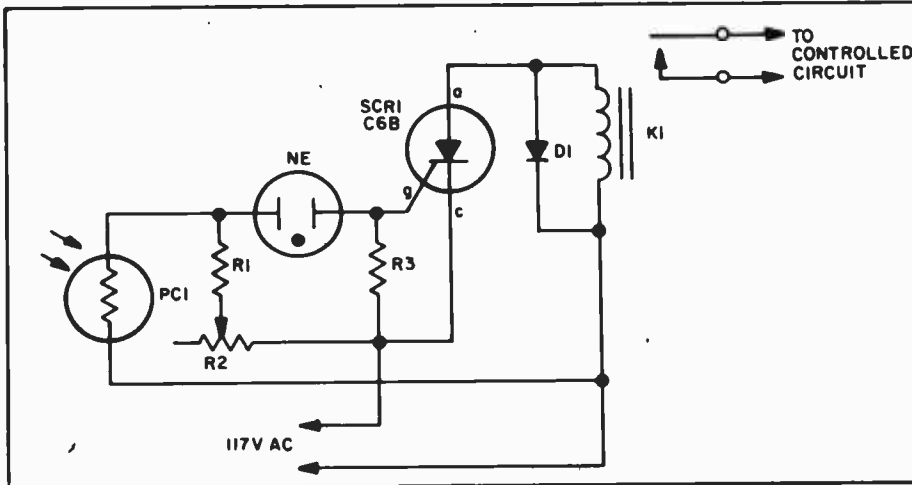

PARTS LIST FOR COMMERCIAL KILLER

- D1—400-PIV silicon rectifier
- K1—117 VAC latching relay (Guardian IR-610L-A115 or equiv.)
- NE—NE-83 neon lamp
- PC1—Clairex photo cell CL505 for high light level; CL704 or CL705 photocell for low light level
- R1—22,000-ohm, 1/2-watt resistor
- R2—1-megohm potentiometer
- R3—100-ohm, 1/2-watt resistor
- SCR1—HEP R1218, 200V, 4A, silicon-controlled rectifier

83 Make A Voltage Doubler

Found in many CB transceivers, the full-wave voltage doubler provides reasonably good regulation with DC output voltage twice the AC input. Capacitors C1 and C2 should be a minimum of 100- μ F and rated at twice the DC output voltage. The larger the capacity, the greater will be the filtering.

On the positive half-cycle, C1 is charged through silicon diode D1. On

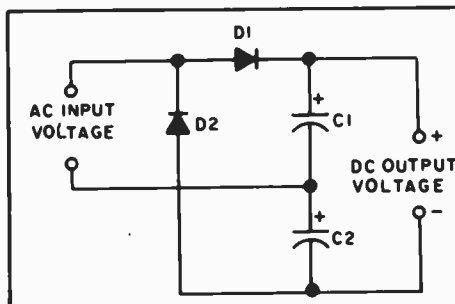

PARTS LIST FOR A VOLTAGE DOUBLER

- C1, C2—100- μ F electrolytic capacitor or larger, WVDC should be twice DC output voltage
- D1, D2—500-milliamper (or larger) rectifying diode rated PIV at least twice DC output voltage

the negative half-cycle, C2 is charged through D2. The DC output voltage

is the sum of the charge across C1 and C2.

84 12 to 9 for Transistors

□ When your auto radio poops out, this regulated voltage adapter keeps you in music from a transistor portable until you're ready to climb under the dash to get at the trouble and fix it.

Power is taken from the 12-volt

auto battery through a cigar lighter plug. The zener diode can be anything with an approximate rating of 9 volts. For example, you can use a 9.1-volt unit (common in Zener kits), or even one rated at 8.6 volts. Make certain the Zener is correctly installed; the

end marked with a band is the cathode.

The adapter is rated for a current of 12 mA maximum. A good rule of thumb is that a radio powered by a Burgess type 2U6 battery can safely operate on the adapter.

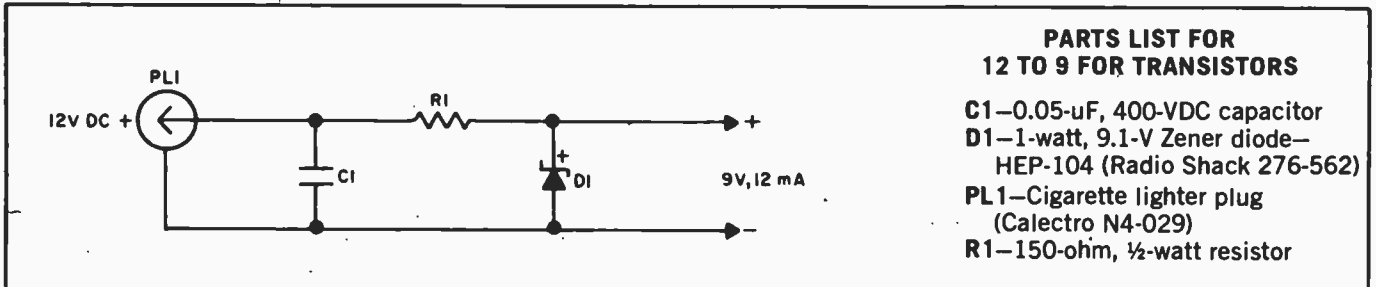

PARTS LIST FOR 12 TO 9 FOR TRANSISTORS

- C1—0.05- μ F, 400-VDC capacitor
- D1—1-watt, 9.1-V Zener diode—HEP-104 (Radio Shack 276-562)
- PL1—Cigarette lighter plug (Calectro N4-029)
- R1—150-ohm, 1/2-watt resistor

85 A Regulated Nine

□ Providing 9 volts at approximately 250 mA, this lab-type power supply will handle many experimenter projects. Actually, T1 can be a 6.3-V imported filament transformer since they usually give approximately 12 V

peak at less than 500 mA output. Change the Zener diode to 12 or 6 volts (and possibly the value of R1) and you get a regulated 12- or 6-volt supply.

For 12 volts you must use a 12-V

filament transformer. Filtering is very good since the electrical filter capacitor equals the value of C2 times the gain of Q1. It can add up to thousands of μ F.

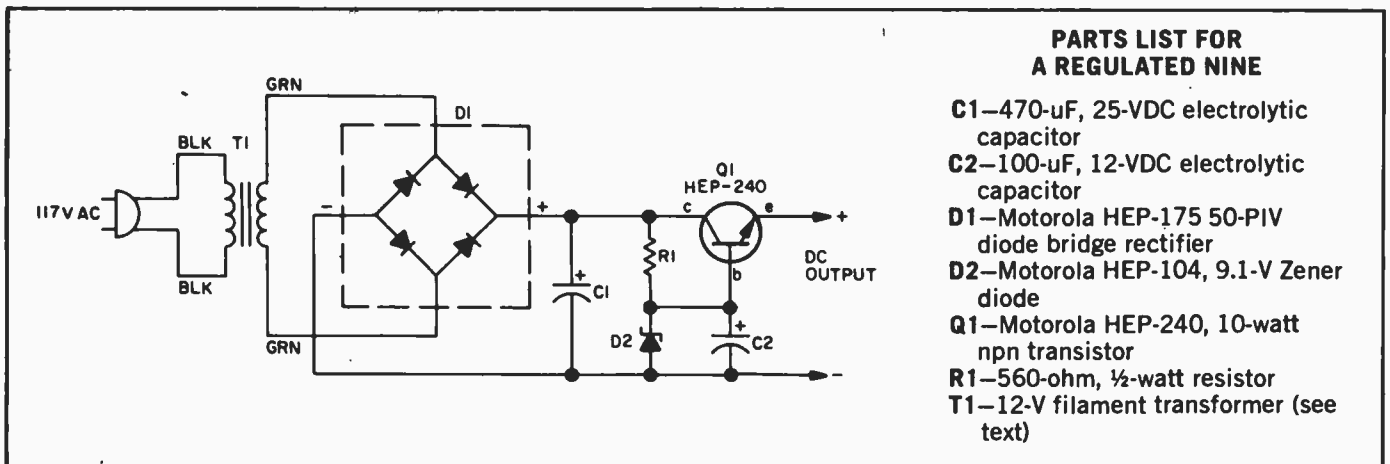

PARTS LIST FOR A REGULATED NINE

- C1—470- μ F, 25-VDC electrolytic capacitor
- C2—100- μ F, 12-VDC electrolytic capacitor
- D1—Motorola HEP-175 50-PIV diode bridge rectifier
- D2—Motorola HEP-104, 9.1-V Zener diode
- Q1—Motorola HEP-240, 10-watt npn transistor
- R1—560-ohm, 1/2-watt resistor
- T1—12-V filament transformer (see text)

86 Dry-Cell Charger

□ This circuit in a fancy commercial package will cost you about \$5. Build a lamp bulb charger yourself and 50¢ may just about do it.

The lamp maintains constant charging of approximately 20 mA through one to four 1.5-volt batteries. But you can go as high as 22.5 volts for either batteries in series or a single battery.

Give small penlight batteries about

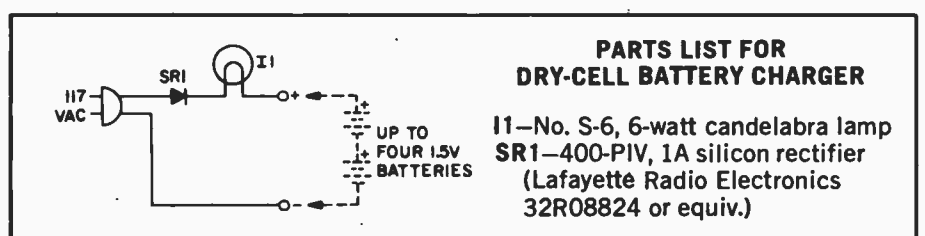

PARTS LIST FOR DRY-CELL BATTERY CHARGER

- I1—No. S-6, 6-watt candelabra lamp
- SR1—400-PIV, 1A silicon rectifier (Lafayette Radio Electronics 32R08824 or equiv.)

10 hours charge, the C and D cells about 20 hours. Yes, you can recharge

NiCads stamped with a charge rate of approximately 20 to 25 mA.

87 Lo-Hum Power Supply

Just a handful of components are needed for a line-powered low-voltage low-current supply for powering audio preamplifiers.

The values for different voltage and current outputs are given in the Parts List. Pick the set you need and wire up. D1 and D2 are silicon rectifiers rated at a minimum of 200 PIV at any current.

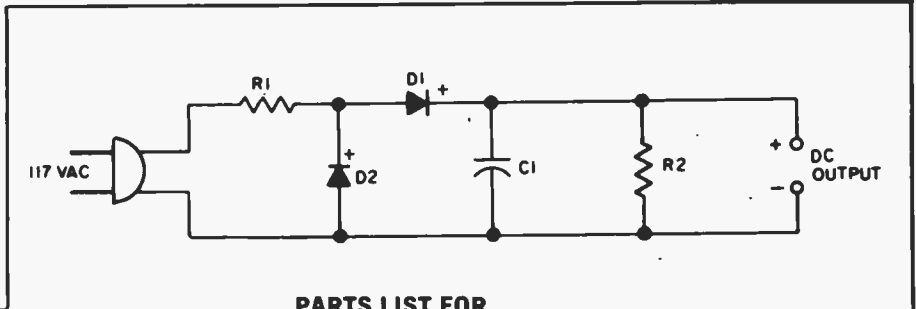

PARTS LIST FOR LO HUM POWER SUPPLY

Out-put V	I max*	R1	C1	R2
12	1 mA	43,000-ohm, ½-watt	250-µF, 15-VDC	180,000-ohm, ½-watt
12	2 mA	22,000-ohm, ½-watt	250-µF, 15-VDC	100,000-ohm, ½-watt
25	2 mA	18,000-ohm, ½-watt	250-µF, 30-VDC	180,000-ohm, ½-watt

*For lower current, decrease value of R2

88 Zener Regulator

When the output from an AC power supply is too high for a solid-state project, chop it down to size with a zener diode voltage regulator and keep it on the button.

To calculate R, first add the load current and 1/20 of the load current for the zener's idling current. Then use Ohm's Law ($R = E/I$) to calculate R. The resistor's power rating

should be twice the calculated power.

The power rating for the zener diode is determined by the voltage across the diode squared, divided by diode's nominal internal resistance. You can calculate the internal resistance by working backwards from the zener's power rating. As an example: a 9-volt, 1-watt zener would have a nominal internal resistance of $R =$

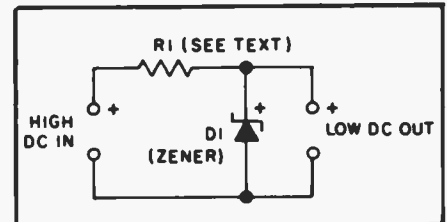

E^2/W , 81/1, or 81 ohms. It's not precisely accurate, but close enough.

89 AC Adapter

It seems that just about everything these days is battery powered, and when something goes bad and you're ready to check it out more than likely the size batteries needed are not in your stock, and it's two hours past store-closing time. But with this universal AC adaptor you can handle just about any battery powered repair job that gets on your test bench. Providing up to 300 mA, you can arrange the output leads of the adaptor to deliver the required polarity connections.

Keep in mind, however, that this AC adaptor is for radios, cassette recorders, and the like. *It is not for calculators.* Some calculators require

an adaptor with an AC output (the rectifier and filter are in the calculator) and this fact isn't indicated anywhere in the instruction manual or on the calculator. Connect an adaptor with a DC output to a calculator requiring an AC input and you probably will be buying a new calculator. So don't claim later you weren't warned.

PARTS LIST FOR AC ADAPTOR

T1—Adaptor transformer, Calectro D1-743

D1-D4—Any silicon rectifier rated at least 25 PIV at 0.5 A.

C1—2000-µF, 15 VDC capacitor

S1—Any switch that can provide 4PST.

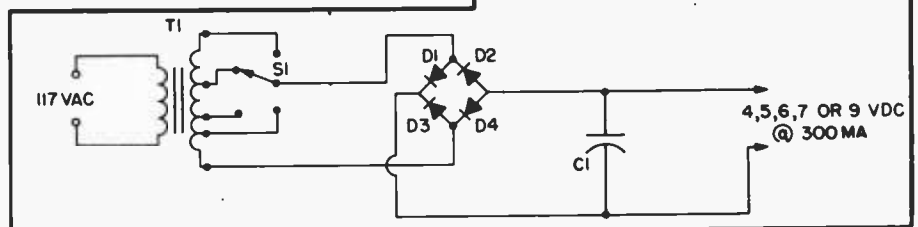

90 AC Line Regulator

☐ Shrinking TV pictures, color shifts, hi-fi amplifiers that don't put out anywhere near their rated power, photographic enlargers requiring extra-long exposures. These are just a few of the symptoms associated with low line voltage. Maybe it's the local electric company "browning" you out because they can't meet the electric surge to power summer cooling (or winter heating), or perhaps your electric wiring capacity is just too low for all the appliances on your line. Whatever, that expensive modern equipment popping out from low line voltage can be brought back to life with an AC variable transformer, often called a variable autotransformer.

The autotransformer normally has an operating output of from 0 to 150 VAC, so that's a reserve of at least

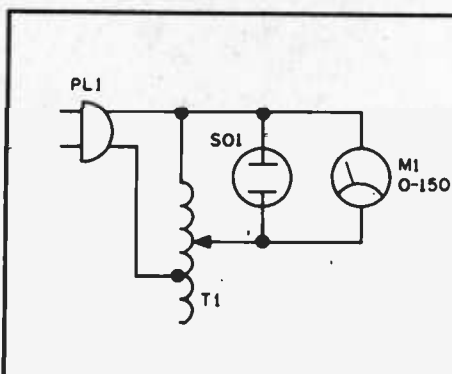

PARTS LIST FOR AC LINE REGULATOR

- M1—0-150 VAC meter (Lafayette Radio Electronics 99R51054 or equiv.)
- PL1—AC plug
- T1—AC power line variable autotransformer (Ohmite type or equivalent, see text)

30 volts. When the power line dips, simply crank up the autotransformer until the meter indicates between 115 and 120 VAC. The device works the same way if your line voltage runs too high; simply crank the transformer down to the desired voltage.

Autotransformers come in many wattage ratings; make certain the one you get can handle the load. As a safety feature, have at least 25 percent reserve capacity. If the load is 150 watts, use an autotransformer rated at least 200 watts.

91 Basic Power Supply

☐ Though the transformer isn't center-tapped in this circuit, the bridge rectifier provides full-wave rectification with an easy-to-filter DC output. It forms a handy supply for solid-state projects.

The output voltage is equal to the secondary voltage multiplied by 1.4. Or, working backwards, the secondary voltage must be 0.707 times the desired output voltage.

Silicon rectifiers D1 through D4

must have a PIV rating equal to at least the DC output voltage. Their current rating must at least equal the current requirements of the project being powered by the supply.

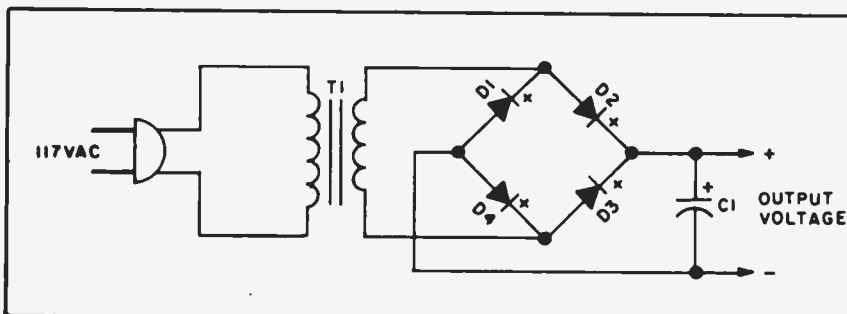

PARTS LIST FOR BASIC POWER SUPPLY

- C1—2500- μ F electrolytic capacitor, voltage rating at least 1.5 times higher than output voltage
- D1, D2, D3, D4—1A, 400-PIV silicon rectifier
- T1—Transformer; 117-VAC primary, secondary voltage equal to desired output voltage \times 0.707

92 Tone Controlled Relay

☐ This tone controlled relay circuit is a lot more complex and more expensive than the usual tone control circuit but it's suggested for use when you need super-sensitivity and/or super-Q (the ability to respond only to the control frequency). Capacitor C8 provides a small delay of about 0.5 second so the unit can distinguish between the control input tone and random frequencies from sounds picked up by, say, a dynamic micro-

phone which can be connected to the input. In typical use potentiometer R1 is adjusted for the minimum input signal that provides reliable tripping of the relay.

The values shown provide an operating frequency of approximately 1500 Hz. The frequency is determined by R9, R10, R11, C4, C5 and C6. The relationship between these components is shown in the schematic. Frequency is calculated with

the formula $F = \frac{1}{2\pi RC}$. Use 4,700-ohm resistors for R10 and R11 even if it limits the range of frequencies you can use.

Virtually any general purpose PNP transistors of the type indicated in the parts list can be used. Diodes D1 and D2 should be the germanium 1N34/1N60 type. Be very careful about all power supply and capacitor polarities.

PARTS LIST FOR TONE CONTROLLED RELAY

Resistors ½ watt, 10%, unless otherwise specified
R1—25,000- to 50,000-ohm linear potentiometer

R2, R10, R11—4,700-ohms
R3—100,000-ohms
R4—10,000-ohms
R5—5,600-ohms

R6—2,200-ohms
R7—1,200-ohms
R8—3,300-ohms
R9—2,400-ohms
R12—47,000-ohms
R13—22-ohms
Capacitors rated 10-VDC or higher
C1, C2, C4—0.047-µF
C3—2-µF
C5, C6—0.022-µF
C7—15-µF
C8—50-µF
Q1, Q2, Q3, Q4—2SB22, (Radio Shack 276-2003 or equiv.)
D1, D2—Germanium diode type 1N60 or equiv.
D3—Silicon rectifier type 1N4001 or equiv.
RY1—Relay, 200- to 400-ohm coil, 6-VDC, P&B RS5D-6 or equiv.

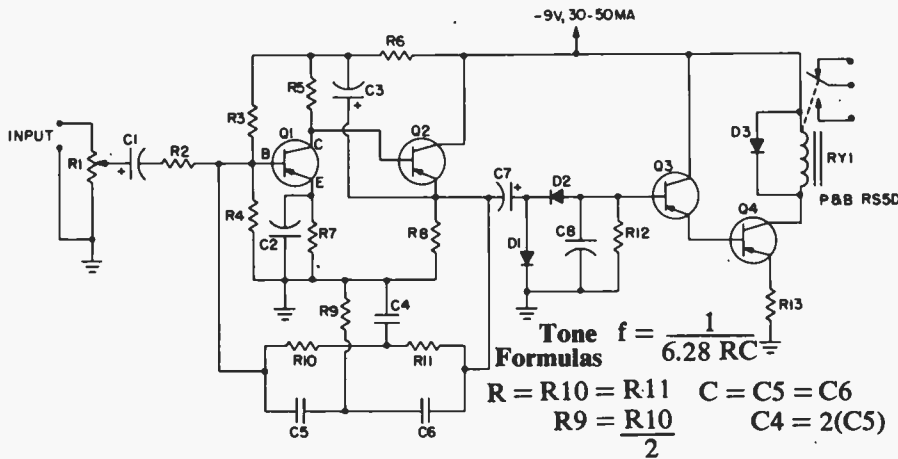

93 Power Tool Torque Control

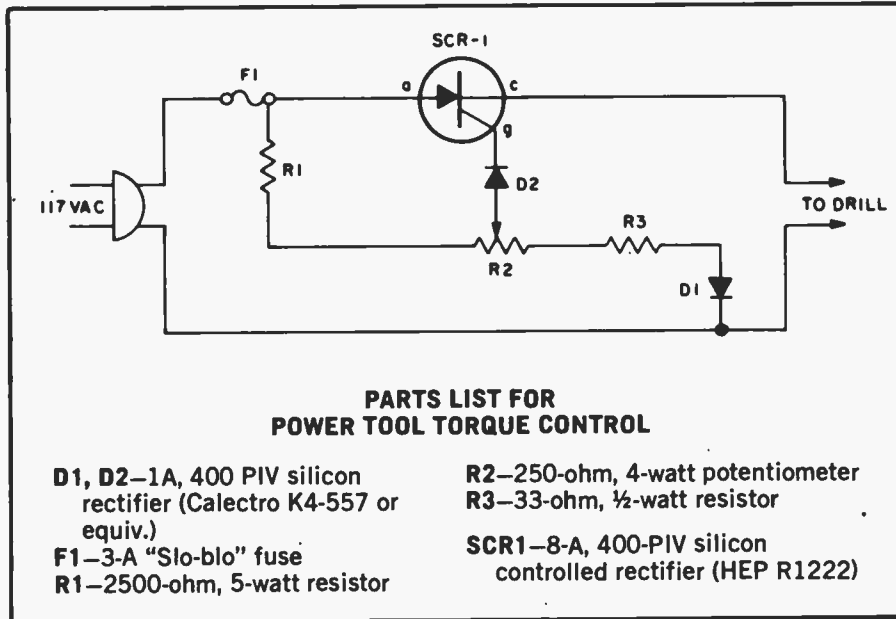

□ As the speed of an electric drill is decreased by loading, its torque also drops. A compensating speed control like this one puts the oomph back into the motor.

When the drill slows down, a back voltage developed across the motor—in series with the SCR cathode and gate—decreases. The SCR gate voltage therefore increases relatively as the back voltage is reduced. The "extra" gate voltage causes the SCR to conduct over a larger angle and more current is driven into the drill, even as speed falls under load.

The only construction precaution is an extra-heavy heat sink for the SCR. The SCR should be mounted in a ¼-in. thick block of aluminum or copper at least 1-in. square; 2-in. if you drill for extended periods.

94 Vari-Rev Motor Control

□ Old universal appliance motors and shaded-pole induction motors salvaged from inexpensive turntables can be easily converted to slow-speed hobby drills, chemical stirrers, vari-speed turntables, movable display drives, etc. It's done with a full-wave Triac speed controller.

Unlike other speed controllers, which require an external trigger device, Q1 combines both the Triac and Diac trigger diodes in the same case.

The motor used for the load must be limited to 6 amperes maximum

(or 740 watts). Triac Q1 must be provided with a heat sink, which can

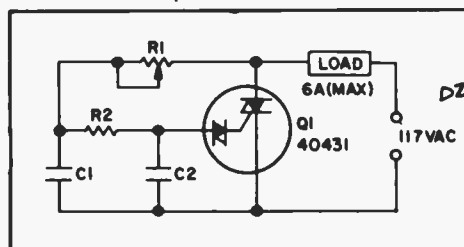

be the metal cabinet. Build up a marblesize mound of epoxy on the cabinet and insert Q1's case into the epoxy. When the epoxy hardens the

Triac's heat is dissipated to the cabinet. Make certain Q1's case is not shorted to the cabinet and is insulated by the epoxy.

With the component values shown on the parts list, the Triac controls motor speed from full *off* to full *on*.

95 Fancy Guitar Fuzzbox

□ Add that way-out fuzz sound to any electric guitar by connecting the Fuzz Box between your guitar and amplifier. Potentiometer R3 sets the degree of fuzz, R8 the output level. Pots R3 and R8 may be any taper you find in your junkbox or that you can pick up at "surplus" prices.

Since the fuzz effect cannot be

completely eliminated by R3, fuzz-free sound requires a bypass switch. The switch, which should completely disconnect the Fuzz Box output, can be any available SPST such as a toggle or pushbutton type; the input can remain in parallel with the bypass switch.

The Fuzz Box can be mounted in a

small minibox or, if there is space in your amplifier and you don't mind cutting there small holes to bring out the potentiometer shafts and to mount the bypass switch, it can go inside your amplifier.

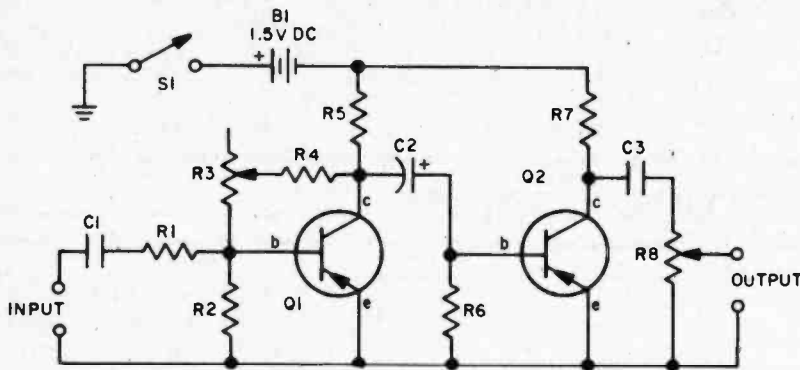

PARTS LIST FOR FANCY GUITAR FUZZBOX

- B1—1.5-V AA battery
- C1, C3—0.1- μ F, 50-VDC capacitor
- C2—4.7- μ F, 10-VDC electrolytic capacitor
- Q1, Q2—pnp transistor—HEP-632
- R1, R6—22,000-ohm, $\frac{1}{2}$ -watt resistor
- R2—18,000-ohm, $\frac{1}{2}$ -watt resistor
- R3—1-megohm pot
- R4—100,000-ohm, $\frac{1}{2}$ -watt resistor
- R5, R7—10,000-ohm, $\frac{1}{2}$ -watt resistor
- R8—50,000-ohm pot
- S1—Spst switch

96 Wide Range Funk Box

□ Fuzz, echo, reverb, big bass, they're all out! The new guitar sound is *funky*, and you'll get it with the wide-range Funk Box. Just crank potentiometer R7 and you'll get an extra twang from way down low to way up high.

While, with a bit of care, just about any type of construction can be used, it's a good idea to button things up pretty tight to avoid RFI (radio

frequency interference). By keeping all leads as short as possible, enclosing the circuitry in a metal box and using standard pre-packaged phone cables (they're shielded), you can cut down on the possibility of having "Rubber Duck" or "Jaybird" breaking through your amplifier and giving out with "10-4 and good numbers ole buddy" just when you're cutting loose with your big number.

If you put the Funk Box into a metal box, use a push switch for S1 and you'll be able to key the effect in and out with your foot. Adjustment is easy, simply vary potentiometer R4 until you hear a whistle (oscillation); then back off R4 until the oscillation just ceases. Connect your guitar to jack J1 and twang away. The effect can be varied from bass to treble by adjusting R7.

PARTS LIST FOR WIDE RANGE FUNK BOX

- B1—9V-type 2U6 battery
- C1, C2—.1- μ F Mylar capacitor
- C3—.47- μ F Mylar capacitor
- C4—.02- μ F Mylar capacitor
- C5, C6—.01- μ F Mylar capacitor
- J1, J2—Phono jack
- Q1—NPN transistor, HEP-722 or 723
- R1, R2—22,000-ohm, $\frac{1}{2}$ -watt resistor
- R3—470,000-ohm, $\frac{1}{2}$ -watt resistor
- R4—2000-ohm trimmer potentiometer

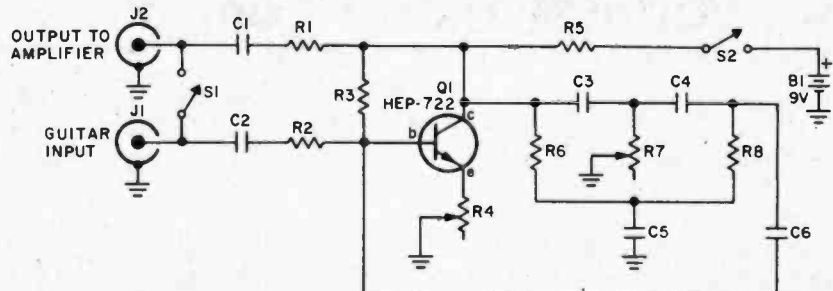

- R5, R6, R8—56,000-ohm, $\frac{1}{2}$ -watt resistor

- R7—10,000-ohm potentiometer
- S1, S2—Spst switch

97 NiCad Battery Charger

□ Providing an adjustable output voltage up to 35 VDC and maximum output current of 50 mA, this battery charger handles just about any NiCad battery used by experimenters.

With only five components the

charger is a quick and easy construction project that will pay real dividends by keeping your NiCads charged and ready to go.

Since transistor Q1 dissipates quite a bit of heat, it must be mounted on

a heat sink. While best to use a regular heat sink, Q1 can be mounted on a metal cabinet. Keep in mind that since Q1's case is also the collector connection is *must* be insulated from the cabinet.

PARTS LIST FOR NICAD BATTERY CHARGER

- C1—100- μ F, 50-V electrolytic capacitor
- D1—1-A, 400 PIV-silicon rectifier (Lafayette Radio Electronics 32R08824 or equiv.)
- Q1—40-W, pnp power transistor
- R1—2000-ohm potentiometer
- T1—24-VAC, 117-VAC primary filament transformer

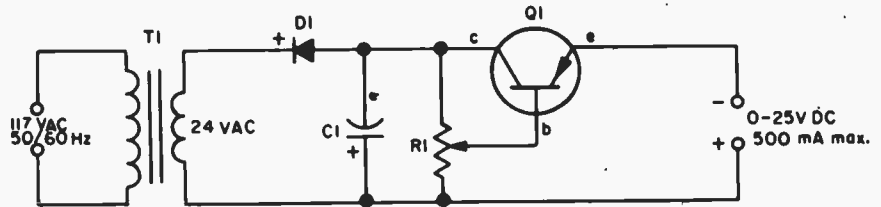

98 AC Motor Power Brake

□ Give it a shot of direct current, and any AC power tool motor will instantly stop. No more free-running power saws or drills with the Power Brake. The unit must be assembled in a metal enclosure as the enclosure provides the heat sink for silicon rectifier D1. This diode has only one solder terminal, the case is the second terminal.

Place a single strip of plastic electrical tape on the bottom of SR1's case, thoroughly coat SR1's case with epoxy adhesive and cement SR1 to the enclosure (heat sink). When the

adhesive is dry solder one connecting wire directly to SR1's case, the remaining wire connects to the terminal. Polarity is not important; any wire can go to any SR1 terminal.

Switch S1 is a center-off, one side spring return. With S1 *on*, AC will be fed to the motor and the motor will run. To brake the motor, simply press S1 down and a quick shot of DC will instantly stop it. The switch returns to the center *off* position when released. This Power Brake can only be used with AC motors; it will not brake universal (AC-DC) motors.

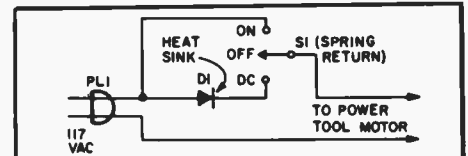

PARTS LIST FOR AC MOTOR POWER BRAKE

- PL1—AC plug
- D1—Silicon rectifier, 200 PIV, 20 A.
- S1—Spdt switch. Center off, one side spring return
- Misc.—Metal cabinet

99 Simple Signaller

□ Using diode switching, a single pair of wires controls two circuits that normally require four wires. Though illustrated here with lamps, the same idea can be used for telephone circuits.

When polarity-reversing switch S1 is set so the positive battery terminal feeds the top wire, the D1/I1 circuit is operative and only lamp I1 lights up. Lamp I2 remains off because diode D2 blocks the flow of DC to the lamp.

When battery polarity is reversed, so the top wire is negative, only D2 conducts, illuminating I2. D1 blocks the current flow and I1 is off.

If a carbon mike is connected in

series with the battery and the lamps are replaced with headphones, switch

S1 determines which of two headphones receives the signal.

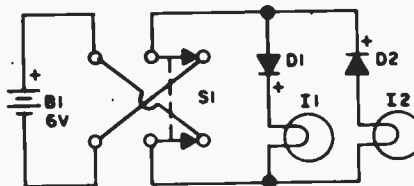

PARTS LIST FOR SIMPLE SIGNALLER

- B1—6-V battery, 4 D-cells in series
- D1, D2—50-PIV 1-A silicon diode (Lafayette Radio Electronics 33R08790 or equiv.)
- I1, I2—6.3-V, 0.15-A, #40 pilot lamp (Radio Shack 272-1128 or equiv.)
- S1—Dpdt toggle switch

100 Yelp Oscillator

□ A real screamer! Use a public-address type amplifier and horn under the hood of your car and you'll punch a hole in the tightest traffic jam. (Be certain, of course, that you hold a position that entitles you to a siren.)

Build this yelper in a small box and hold the PA mike 2-3 inches from the 8-ohm speaker. Press push-button switch S2 and the siren starts up, shifting to a higher frequency. Release it and the tone slides down

until you press S2. Tone quality is adjusted by changing C2. If the siren pulsates before S1 is pressed, Q1 is too "leaky."

PARTS LIST FOR YELP OSCILLATOR

- B1—6-V or 12-V battery
- C1—30- μ F, 15-VDC electrolytic capacitor
- C2—0.02- μ F, 75-VDC capacitor
- Q1—Motorola HEP-53 npn transistor (Radio Shack 276-2009)
- Q2—Motorola HEP-702 pnp transistor
- R1, R2—56,000-ohm, $\frac{1}{2}$ -watt resistor
- R3—27,000-ohm, $\frac{1}{2}$ -watt resistor
- S1—Spst switch
- S2—N.O. pushbutton switch (Calectro E2-142)
- SPKR—8-ohm speaker or PA horn (Calectro S2-245/6 or equiv.)

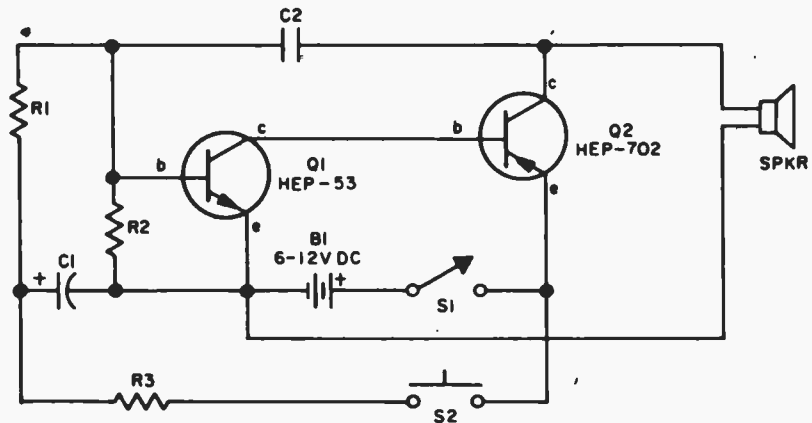

101 Twang-A-Matic

□ It seems no one cares for the sound of a plain, unadorned guitar. First they added fuzz, then big-boom bass, next it was reverberation and screaming highs. Now the in sound is *twang*, a guitar sound that more or less approximates a banjo or mandolin. A Twang-A-Matic produces these unusual sounds from an ordinary electric guitar by cutting the bass, severely distorting the midband and highs, and then amplifying the distortion. It might read "bad" to you, but it sure sounds good!

You can assemble the Twang-A-Matic in any type of cabinet. Switch S1 cuts the effect in and out while switch S2 turns the unit on and off. Output control R7 should be set so the Twang-A-Matic has the same volume level as the straight guitar feed-through. Various degrees of twang are obtained by varying the output so the guitar picks up with the level controls built into the guitar.

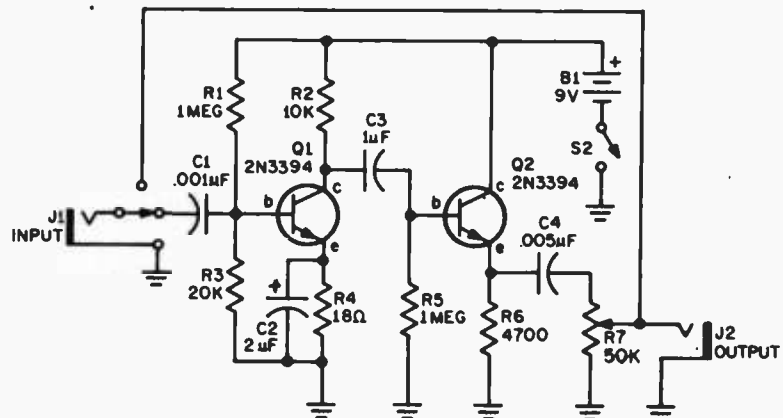

PARTS LIST FOR TWANG-A-MATIC

- | | |
|---|--|
| <ul style="list-style-type: none"> B1—9-volt battery (Eveready 246 or equiv.) C1—0.001-μF disc capacitor 25 VDC or better C2—2-μF electrolytic capacitor, 15 VDC or better. C3—1-μF electrolytic capacitor, 15 VDC or better C4—0.005-μF disc capacitor, 15 VDC or better J1, J2—Phone jack | <ul style="list-style-type: none"> Q1, Q2—NPN transistor, 2N3394 R1, R5—1 megohm, $\frac{1}{2}$-watt resistor R2—10,000, $\frac{1}{2}$-watt resistor R3—20,000-ohm, $\frac{1}{2}$-watt resistor, 5 percent R4—18-ohm, $\frac{1}{2}$-watt resistor R6—4700-ohm, $\frac{1}{2}$-watt resistor R7—50,000-ohm potentiometer S1—Switch, spdt (twang in-out) S2—Switch, spst (on-off) |
|---|--|

LITERATURE LIBRARY

301. Get acquainted with the new *EICO* products, designed for the professional technician and electronics hobbyist. Included in brochure are 7 IC project kits, *EICO's* "Foneside," security products and many varied kits.

302. *International Crystal* has illustrated folders containing product information on radio communications kits for experimenters (PC boards; crystals; transistor RF mixers & amplifiers; etc.).

303. *Regency* has a new low cost/high performance UHF/FM repeater. Also in the low price is their 10-channel monitor radio scanner that offers 5-band performance.

304. *Dynascan's* new *B & K* catalog features test equipment for industrial labs, schools, and TV servicing.

305. Before you build from scratch, check the *Fair Radio Sales* latest catalog for surplus gear.

306. Get *Antenna Specialists'* catalog of latest mobile antennas, test equipment, wattmeters, accessories.

307. Want a deluxe CB base station? Then get the specs on *Tram's* super CB rigs.

308. Compact is the word for *Xcelite's* 9 different sets of midget screwdrivers and nutdrivers with "piggyback" handle to increase length and torque. A handy show case serves as a bench stand also.

310. *Turner* has two booklets on their Signal Kicker antennas. They give specifications and prices on their variety of CB base and mobile line. Construction details help in your choice.

311. *Midland Communications'* line of base, mobile and hand-held CB equipment, marine transceivers, scanning monitors, plus a sampling of accessories are covered in a colorful 18-page brochure.

312. *The EDI (Electronic Distributors, Inc.)* catalog is updated 5 times a year. It has an index of manufacturers literally from A to X (ADC to Xcelite). Whether you want to spend 29 cents for a pilot-light socket or \$699.95 for a stereo AM/FM receiver, you'll find it here.

313. Get all the facts on *Progressive Edu-Kits* Home Radio Course. Build 20 radios and electronic circuits; parts, tools, and instructions included.

315. *Trigger Electronics* has a complete catalog of equipment for those in electronics. Included are kits, parts, ham gear, CB, hi fi and recording equipment.

316. Get the *Hustler* brochure illustrating their complete line of CB and monitor radio antennas.

317. *Teaberry's* new brochure presents their complete lines of CB and marine transceivers and scanners for monitoring police, fire and other public service frequencies.

318. CBers, *GC Electronics'* 16-page catalog offers the latest in CB accessories. There are base and mobile mikes and antennas; phone plugs; adaptors and connectors; antenna switchers and matchers; TVI filters; automotive noise suppressor kits; SWR power and FS meters; etc.

318. *Browning's* mobiles and its famous Golden Eagle base station, are illustrated in detail in the new 1977 catalog. It has full-color photos and specification data on Golden Eagle, LTD and SST models, and on "Brownie," a dramatic new mini-mobile.

320. *Edmund Scientific's* new catalog contains over 4500 products that embrace many sciences and fields.

321. *Cornell Electronics'* "Imperial Thrift Tag Sale" Catalog features TV and radio tubes. You can also find almost anything in electronics.

322. *Radio Shack's* 1977 catalog colorfully illustrates their complete range of kit and wired products for electronics enthusiasts—CB, ham, SWL, hi-fi, experimenter kits, batteries, tools, tubes, wire, cable, etc.

323. Get *Lafayette* Dole's "new look" 1977 catalog with 260 pages of complete electronics equipment. It has larger pictures and easy-to-read type. Over 18,000 items cover hi-fi, CB, ham rigs, accessories, test equipment and tools.

327. *Avanti's* new brochure compares the quality difference between an Avanti Racer 27 base loaded mobile antenna and a typical imported base loaded antenna.

328. A new free catalog is available from *McGee Radio*. It contains electronic product bargains.

329. Semiconductor Supermart is a new 1977 catalog listing project builders' parts, popular CB gear, and test equipment. It features semiconductors—all from *Circuit Specialists*.

330. There are over 450 electronic kits described in *Heath's* new catalog. Virtually every do-it-yourself interest is included—TV, radios, stereo & 4-channel, hi-fi, etc.

331. *E. F. Johnson* offers their CB 2-way radio catalog to help you when you make the American vacation scene. A selection guide to the features of the various messenger models will aid you as you go through the book.

332. If you want courses in assembling your own TV kits, *National Schools* has 10 from which to choose. There is a plan for GIs.

333. Get the new free catalog from *Howard W. Sams*. It describes 100's of books for hobbyists and technicians—books on projects, basic electronics and related subjects.

334. *Sprague Products* has L.E.D. readouts for those who want to build electronic clocks, calculators, etc. Parts lists and helpful schematics are included.

335. The latest edition of the *TAB BOOKS* catalog describes over 450 books on CB, electronics, broadcasting, do-it-yourself, hobby, radio, TV, hi-fi, and CB and TV servicing.

337. *Pace* communications equipment covers 2-way radios for business, industrial and CB operations. Marine radiotelephones and scanning receivers are also in this 18-p. book.

338. "Break Break," a booklet which came into existence at the request of hundreds of CBers, contains real life stories of incidents taking place on America's highways and byways. Compiled by the *Shakespeare Company*, it is available on a first come, first serve basis.

342. *Royce Electronics'* new full-color catalog updates information on their CB transceivers (base, mobile, handheld). It also describes new product lines—CB antennas and a VHF marine radiotelephone.

344. For a packetful of material, send for *SBE's* material on UHF and VHF scanners, CB mobile transceivers, walkie-talkies, slow-scan TV systems, marine-radios, two-way radios, and accessories.

345. For CBers from *Hy-Gain Electronics Corp.* there is a 50-page, 4-color catalog (base, mobile and marine transceivers, antennas, and accessories). Colorful literature illustrating two models of monitor-scanners is also available.

350. Send for the free *NRI/McGraw Hill* 100-page color catalog detailing over 15 electronics courses. Courses cover TV-audio servicing, industrial and digital computer electronics, CB communications servicing, among others. G.I. Bill approved, courses are sold by mail.

352. Send for the free descriptive bulletin from *Finney Co.* It tells all about their new auto FM radio signal booster (eliminates signal fading).

353. *MFJ* offers a free catalog of amateur radio equipment—CW and SSB audio filters, electronic components, etc. Other lit. is free.

354. A government FCC License can help you qualify for a career in electronics. Send for information from *Cleveland Institute of Electronics*.

355. New for CBers from *Anixter-Mark* is a colorful 4-page brochure detailing their line of base station and mobile antennas, including 6 models of the famous Mark Hellwhip.

356. Send for *Continental Specialties* new bread-boarding prototest devices. They vary in price from a mini-budget kit at \$19.95. Featured is the new logic monitor, giving information on what it does, how it works, and how to use it.

357. *Dage Scientific Instruments* offers a 16-page booklet on how to build an electronic thermometer with control. Included is an introductory course on thermocouples, schematics and many applications.

358. *PixTronics* announces its new Model 200 Super Sensitive Electronic Darkroom Exposure Meter, used to determine the correct exposures of all black-and-white and color negatives. Useable with any enlarger.

359. *Electronics Book Club* has literature on how to get up to 3 electronics books (retailing at \$58.70) for only 99 cents each . . . plus a sample Club News package.

101 ELECTRONIC PROJECTS
Box 1849, G.P.O.
New York, NY 10001

1977 Edition

Void After August 19, 1977

Please arrange to have the literature whose numbers I have circled below sent to me as soon as possible. I am enclosing 50¢ for each group of 5 to cover handling. (No stamps, please.) Allow 4-6 weeks for delivery.

301	302	303	304	305	306	307	308	310	311	312	313
315	316	317	318	319	320	321	322	323	327	328	329
330	331	332	333	334	335	337	338	342	344	345	350
352	353	354	355	356	357	358	359				

NAME (print clearly)

ADDRESS

CITY

STATE

ZIP

30 INTEGRATED CIRCUIT PROJECTS

IC1 SWL's Super Calibrator

□ Providing WWV referenced outputs at 1 MHz, 100 kHz, 10 kHz and 1 kHz, this super calibrator looks quite difficult to assemble, but if you lay it out for a printed circuit board you'll find it's one of the easiest projects to build and get working because there's very little that can go wrong if the ICs and the crystal are okay.

IC1 serves as both the oscillator and buffer amplifier. Another buffer amplifier is used for the output amplifier (terminals 11, 12 and 13),

IC1's output at pin 8 is a buffered 1 MHz. ICs 2, 3 and 4 are *divide by 10 frequency dividers* providing outputs of 100 kHz, 10 kHz and 1 kHz. Since all outputs are square waveform, all output signals are rich in harmonics and so can be used to calibrate receiver dials to well above 60 MHz for the 1 MHz output and to at least 30 MHz for the 100 kHz and 10 kHz outputs. The 1 kHz harmonics can range up to 30 MHz depending on your receiver's sensitivity. The calibrator's output at jack J1 can be con-

nected directly to the receiver's antenna input terminals without affecting the calibrator's output frequency.

The unit is set to zero-beat with WWV with trimmer capacitor C4. It can be assembled in any type of cabinet, but a PC board is specifically recommended for circuit stability.

Power must come from a 5-volt regulated source and we recommend the LM340 5-volt three-terminal regulator for this project. Make certain capacitor C1 is installed as close as possible to IC1 pin 14.

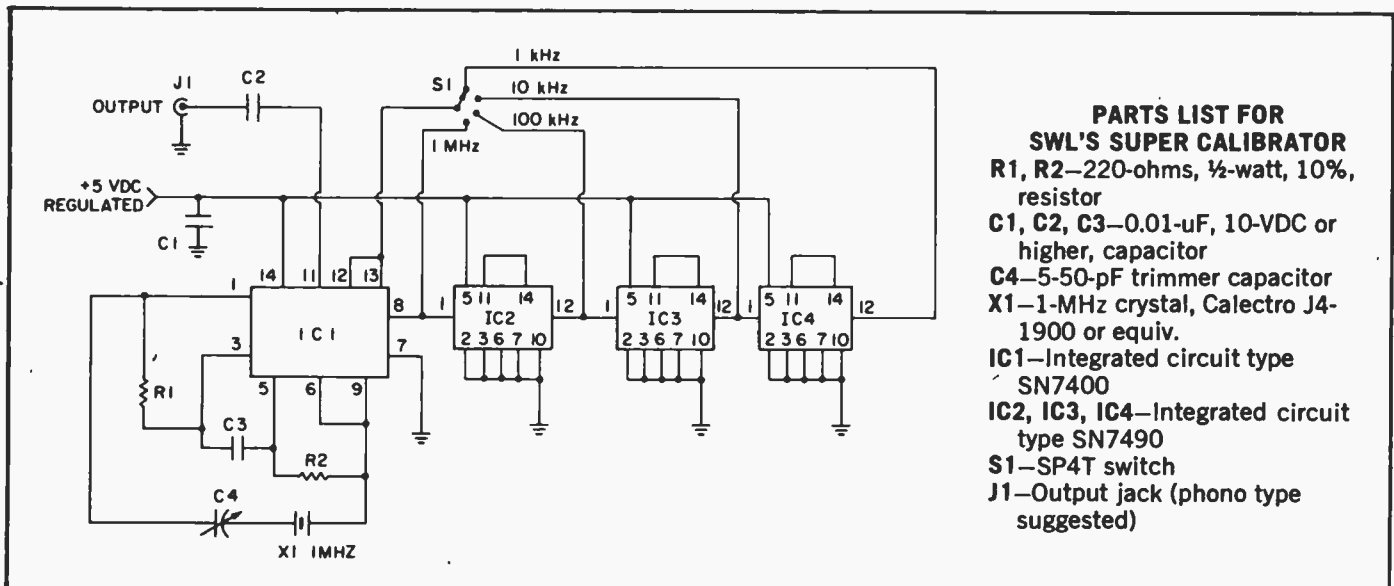

- PARTS LIST FOR
SWL'S SUPER CALIBRATOR**
- R1, R2—220-ohms, ½-watt, 10%, resistor
 - C1, C2, C3—0.01-μF, 10-VDC or higher, capacitor
 - C4—5-50-pF trimmer capacitor
 - X1—1-MHz crystal, Calectro J4-1900 or equiv.
 - IC1—Integrated circuit type SN7400
 - IC2, IC3, IC4—Integrated circuit type SN7490
 - S1—SP4T switch
 - J1—Output jack (phono type suggested)

IC2 Lie Detector

□ When a person is under mental stress one of the physiological changes includes a lowering of the body's skin resistance, and one of the characteristics measured by the modern lie detector is skin resistance.

Our "lie detector" works the same way: it measures the body's skin resistance. In typical use you would

connect one test probe, actually a length of non-insulated wire taped to the skin, to each hand, arm, or wrist, adjust control R2 for a meter null (zero meter reading), and then ask your questions. If a question causes the subject mental stress you will usually see this stress indicated by an increase in the meter reading.

Potentiometer R4 serves as a sensitivity control. To avoid pinning the meter start with R4 at about the mid position: increasing the resistance increases the gain, while decreasing the resistance reduces the gain and the meter reading.

If you want to avoid taping the probes to your subject you can use

the inexpensive, less-than-\$1-a-pair bicycle clips available in most department and sporting goods stores. Solder the test probe wires to the clips and then bend the clips so they hold onto the hand or arm gently but firmly. Wiping the area under the clips with alcohol will improve overall sensitivity.

If long test probes are used, say in excess of 3-feet, shielded wire is suggested, with the shield for each test probe wire connected to the chassis ground—the junction between switches S1a and S1b. You can also use two-wire shielded cable (two wires in one shield) and fan the wires out a foot or so from under the probe end.

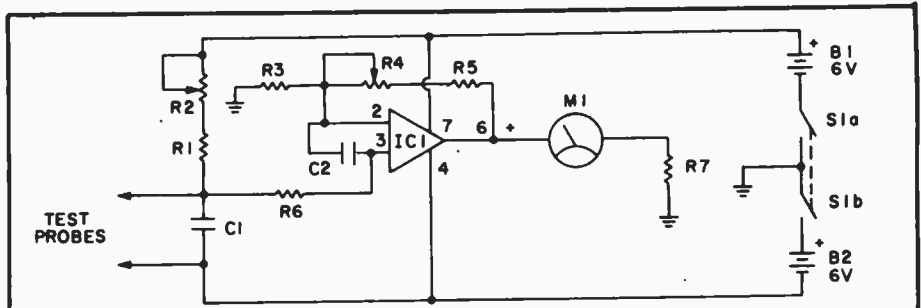

PARTS LIST FOR LIE DETECTOR

- Resistors 1/2- or 1/4-watt, 10%, unless otherwise specified
- R1, R5—10,000-ohms
- R2, R4—1-megohm potentiometer
- R3, R6—1,000-ohms
- R7—560-ohms
- C1, C2—0.01-uF, 25 VDC or higher
- IC1—Operational amplifier, type 741
- S1—Switch, DPST
- B1, B2—6 volt battery, Burgess Z4 or equiv.
- M1—Meter, 0-1 mA DC

IC3 CB Mobile-to-Base Power Unit

□ CB mobile transceivers and 3 to 5-watt CB handie-talkies are easily converted to base station operation with this 13.8 volt regulated power unit. Transformers T1 and T2 should be rated 2 amperes. When T1 and T2's secondaries are connected, test the transformer(s) output voltage with an AC voltmeter. If the meter indicates approximately 6.3 volts, reverse the connections of *either* transformer's *primary or secondary*, but *not both*. The meter will then

read about 18 VAC. Complete the rest of this project only after you are certain the output voltage from the transformer(s) is about 18 VAC.

IC1 must be heat sunk to the cabinet. Note that IC1's tab is a "hot" terminal; make certain it is insulated from the cabinet with a power transistor insulator or a mica washer. Coat both sides of the insulator (washer) with silicon heat sink grease. And make certain the mounting screw is insulated from the

cabinet; use fiber shoulder washers under the screw.

Connect rectifier D2 exactly where shown in the circuit. D2 should be rated at least 50 PIV at 3 amperes. Bridge rectifier D1 is rated 50 PIV at 6 amperes. Do not substitute a 3 ampere bridge rectifier for D1 unless you heat sink it to the chassis. (Heat sinking for D1 is suggested for both the 3 and 6 ampere types.)

**PARTS LIST FOR
CB MOBILE-TO-BASE POWER UNIT**

- C1—2000-uF, 25-VDC electrolytic capacitor
- C2—0.1-uF Mylar capacitor
- C3—500-uF, 25-VDC electrolytic capacitor
- D1—Bridge rectifier, see text
- D2—Silicon rectifier, 50 PIV, 3 amperes
- IC1—Voltage regulator, LM-340-15 (T-package)
- T1—12-volt, 2-ampere filament transformer
- T2—6.3-volt, 2-ampere filament transformer

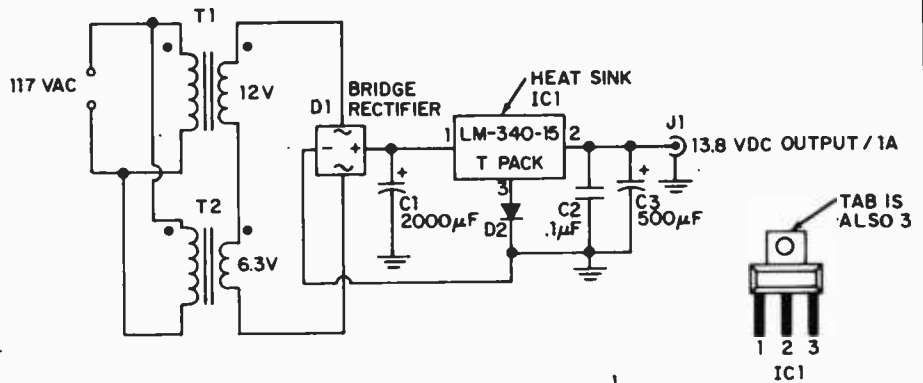

IC4 CB Channel Booster

□ Connect the CB Channel Puller ahead of a low cost receiver, and you'll hear CB signals as if they were coming from your backyard. Using

no tuned circuits, this CB signal booster delivers approximately 15dB overall gain—that's about 3 S-units! Only restriction is that this little rf

amplifier be used with a communications-type receiver having an antenna trimmer. It cannot be used in front of a low-impedance-input type

CB transceiver. Seems the low impedance antenna input common to CB units will sharply reduce the booster's gain.

Typical of all RF amplifiers, the booster requires very short connecting leads. In particular, solder capacitor C3 right at pin 4. Integrated circuit IC1 can be soldered directly into the circuit or a socket can be used. Battery B1 is a 6V Z4 type or larger.

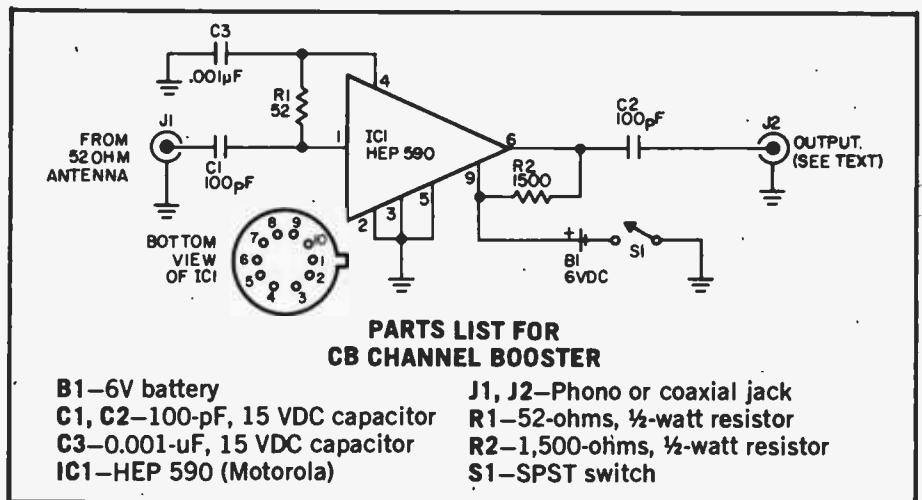

IC5 5V/3A For Digital Projects

□ The 5-volt power supply is almost the universal power source for digital projects. Only problem is the 5 volts must be highly regulated, for a power line transient riding through the supply can zap a board full of ICs. This supply gives you full protection against transients, as well as providing tight regulation. The entire regulator is contained in IC1; no other components other than the filter capacitor and rectifier are needed. For full 5 ampere output IC1 requires a

heat sink of 30 square inches; but if you use a metal cabinet 3 x 4 x 5 inches or larger the cabinet itself serves as the heat sink. Since pin 3 on IC1 is grounded (to the cabinet), all you need is some silicon heat sink grease between the IC and the cabinet—no insulator.

Power transformer T1 must be rated for the maximum current you will use or need. If you want the full 5 amperes T1 must be rated 5 amperes. But if you will need less cur-

rent, say 2 amperes, T1 can be rated 2 amperes.

Rectifiers O1 through O2 are available with ratings up to 3 amperes in the standard coaxial mounting. For greater current capacity the rectifiers must be heat-sinked (electrically isolated) to the cabinet, or other sink. A 10-ampere bridge rectifier such as sold by Calectro and Radio Shack can be substituted, but make certain it is heat sunk to the chassis.

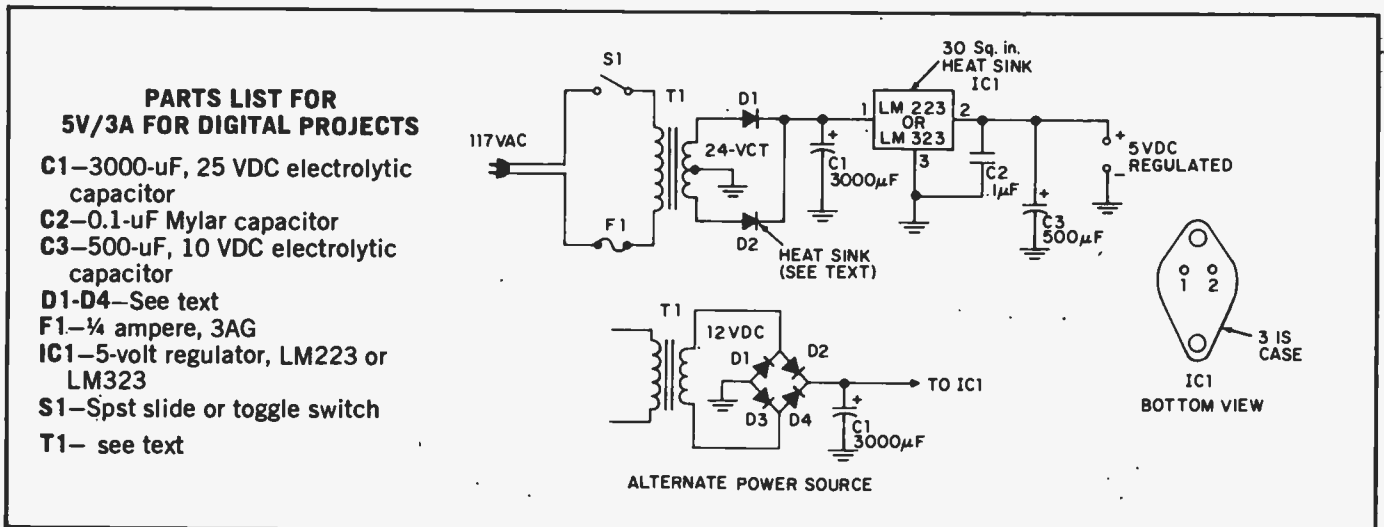

IC6 Bi-Polar Power Supply

□ Most IC circuits require a Bi-Polar power supply. That is, a power source with two outputs—one positive with respect to ground and the other negative with respect to ground. A standard bridge rectifier circuit will provide a Bi-Polar output if the transformer's secondary is center-tapped to ground.

Filter capacitors C1 and C2 should be at least 1000 uF (2000 uF preferred) at a voltage rating at least equal to the supply's output voltage.

The supply's output voltage is equal to 1.4 times E_s . Voltage E_s equals one-half Transformer T1's peak secondary voltage. For exam-

ple, assume that T1's secondary voltage is 24 volts (rms) center-tapped; the voltage on each side of the center-tap (E_s) is 12. The supply's output voltage is therefore 12×1.4 or ± 16.8 VDC. Always remember that each Bi-Polar output is derived from half T1's secondary voltage.

PARTS LIST FOR BI-POLAR POWER SUPPLY

- C1, C2**—1000 or 2000- μ F capacitor at the supply's output voltage
SR1-SR4—Silicon rectifiers PIV rated to at least twice the supply's output voltage
T1—Power transformer with center-tapped secondary (Calectro D1-752)

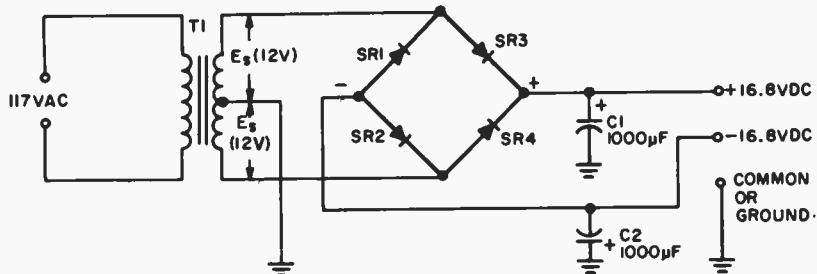

IC7 Bi-Polar Power Amp

It is inconvenient when working with IC preamplifiers requiring bi-polar power sources to convert to a single-ended power source for the power amplifier. Our Bi-Polar Amp, however, can be driven from a bi-polar power supply. One of the benefits enjoyed by Bi-Polar Amp is that a

large, expensive output coupling capacitor isn't needed. Since the device responds well into the high frequency range, capacitors C2 and C3 must be placed directly at the IC terminals to prevent high frequency oscillation. While capacitor C1 can be an electrolytic type, a non-polarized 1 μ F is

suggested.

The amplifier's input impedance is 10,000 ohms, a suitable value for solid-state projects. Voltage gain is 36. If less overall gain is required (say, 10X), disconnect pins 2 and 4 and connect pin 5 to ground through capacitor C5.

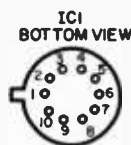

NOTE: LEAD 7 OF IC1 IS CONNECTED TO CASE

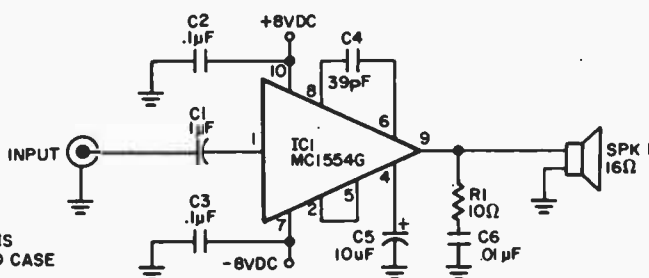

PARTS LIST FOR BI-POLAR POWER AMP

- C1**—1- μ F, voltage rating at least equal to peak input voltage from preceding stage, capacitor
C2, C3—0.1- μ F, 10 VDC capacitor
C4—39-pF, 100 VDC disc capacitor
C5—10- μ F, 10 VDC capacitor
C6—0.01- μ F, 25 VDC capacitor
IC1—Motorola MC-1554G
R1—10-ohms, 1/2-watt resistor
SPK1—16-ohm speaker

IC8 Groove Booster

Using a dual operational amplifier IC, the Groove Booster will provide a fully equalized 1 V rms output from standard phono magnetic pickups. The terminal numbers which are circled on the schematic are the connections for one of the two independent stereo amplifiers on the single IC chip.

The uncircled numbers are the terminals for the stereo second IC. Power supply terminals #14 and #7 are common to both stereo amplifiers. Note that the power supply is ± 12 volts to ground. Two 6-volt batteries in series can be used for each side of the power supply. If batteries are used, connect 25- μ F capacitors from pins 7 and 14 to ground—and get their polarity correct.

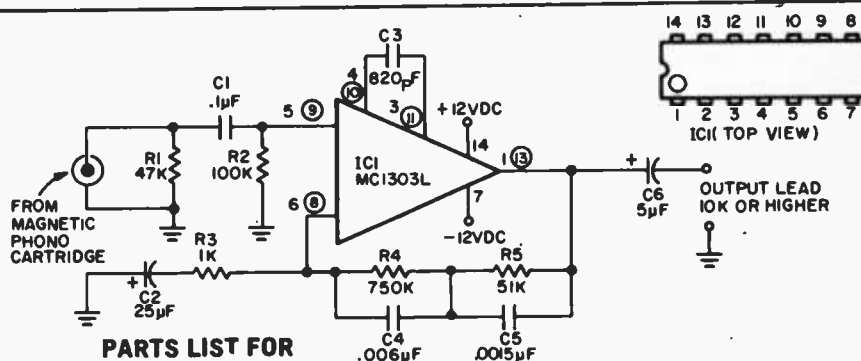

PARTS LIST FOR GROOVE BOOSTER

- C1**—0.1- μ F, 3 VDC capacitor
C2—25- μ F, 3 VDC capacitor
C3—820-pF, 500V VDC disc capacitor
C4—0.006- μ F, 100V VDC disc capacitor
C5—0.0015- μ F, 100V VDC disc capacitor
C6—5- μ F, 25 VDC capacitor
IC1—Motorola MC1303L
R1—47,000-ohms, 1/2-watt resistor
R2—100,000-ohms, 1/2-watt resistor
R3—1,000-ohms, 1/2-watt resistor
R4—750,000-ohms, 1/2-watt resistor
R5—51,000-ohms, 1/2-watt resistor

IC9 Photo Timer

□ You can spend \$50 to \$125 for a photo-enlarger timer but chances are you're not going to get more than a fancy version of this easy-to-build circuit. If you use a DPDT relay, as shown, your safelights can be wired to turn on when the enlarger turns off and vice versa.

If R2 is 1-megohm the timer's range is about 1 to 110 seconds. If R2 is 1.5-megohms the timer's range is approximately 1 to 165 seconds. The precise range will be determined primarily by C2's accuracy, so use a reasonably good quality capacitor for C2, but don't get a precision or MIL-spec part; it's not necessary.

If you use a low current relay for RY1, say less than 100-mA at 6-VDC, you can eliminate Q1 and connect the relay directly from IC terminal 3 to ground. If you use a heavy-duty relay, as high as 300-mA at 6-volts, use Q1. The power input should be 6-volts (doesn't have to be regulated) at 300-mA, or 500-mA for a heavy-duty relay. We suggest any popular-brand low cost relay, such as P&B, Magnacraft or Calectro.

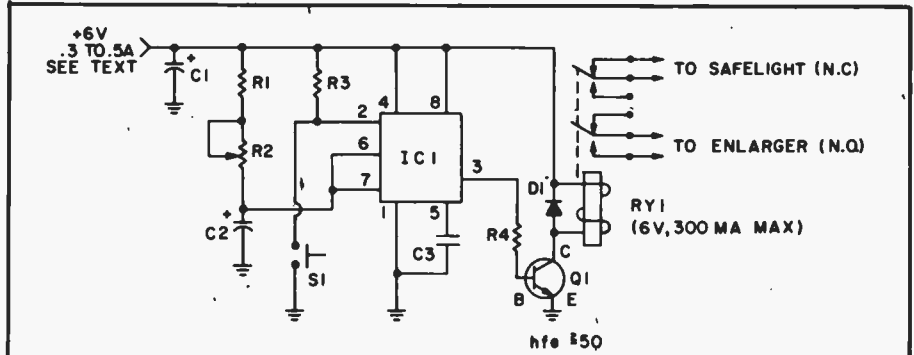

PARTS LIST FOR PHOTO TIMER

Resistors ½ watt, 10%, unless otherwise specified.

R1—10,000-ohms

R2—1.0- or 1.5-megohm linear taper potentiometer (see text)

R3—22,000-ohms

R4—560-ohms

Capacitors rated 6-VDC or higher

C1—100- μ F electrolytic

C2—100- μ F electrolytic (see text)

C3—0.01- μ F capacitor

IC1—Integrated circuit timer type 555 (any package)

Q1—NPN transistor, Radio Shack 276-2030 or equiv.

D1—Silicon rectifier, 1N4003, equiv. or higher PIV rating.

RY1—6-VDC relay, see text

S1—N.O. push-button or momentary contact switch.

Potentiometer R2 should be linear taper. After the timer is assembled attach a large pointer knob to R1's shaft, and using an electric clock with a sweep second hand as a reference, calibrate timing control R2.

If the unit is assembled in a metal cabinet use a three-wire linecord to ground the cabinet. If you use an all plastic cabinet with no exposed metal hardware that can be touched you can use a two-wire linecord.

IC10 Bargain Tape Preamp

□ From time to time you'll find bargains at dealers selling tape and cassette deck mechanisms at rock bottom prices—often less than \$20! Complete with heads, these decks need only the electronics to get them working. The preamp provides both the amplification and equalization. You can feed its output directly into an amplifier's auxiliary input. Overall frequency re-

sponse is suitable for cassettes and 3¼ IPS reel-to-reel tapes. Since the actual required equalization is determined partially by the playback head characteristics, it might be necessary to modify or "tailor" the equalization; this is done by small changes in the value of capacitor C3 and resistor R5.

If assembled on a small printed circuit board, the preamp can be

tucked under the tape mechanism's base plate. The power supply can be anything from 9 to 18 volts at approximately 3 mA. Transistor type radio batteries will do; if batteries are used they must be bypassed with a 25- μ F capacitor. And, be sure you observe proper battery polarity.

PARTS LIST FOR BARGAIN TAPE PREAMP

C1, C2—25- μ F, 6 VDC capacitor

C3—0.005- μ F capacitor

C4—10- μ F, 20 VDC capacitor

C5—0.001- μ F capacitor

IC1—Motorola MFC-4010

R1, R4—3,900 ohms, ½-watt resistor

R2—39,000-ohms, ½-watt resistor

R3—560,000-ohms, ½-watt resistor

R5—56,000-ohms, ½-watt resistor

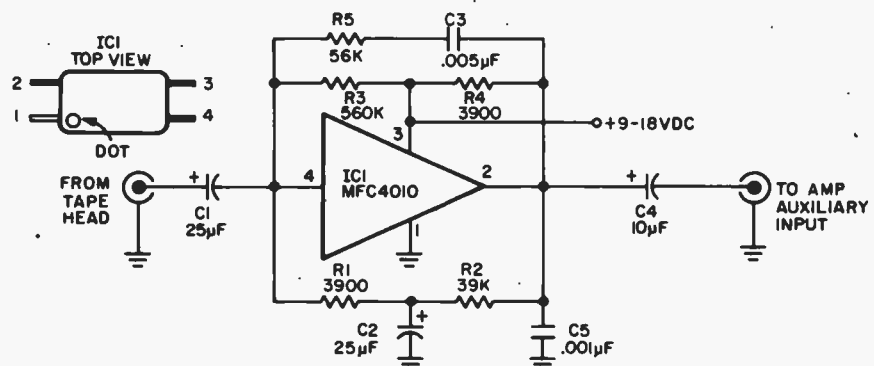

IC11 Mighty Mite Signal Tracer

□ Featuring extremely high gain suitable for tracing signals directly from microphones and magnetic pickups, our Mighty Mite signal tracer can be made small enough to sit directly on the back of the speaker magnet. Though intended for checking transistor circuits, Mighty Mite can be used with tubed equipment if capacitor C1 has a 600 VDC minimum rating, and if volume control R1 is always started from its off position. Regardless of the size speaker used, Mighty Mite's speaker impedance must be 16 ohms minimum, though higher impedances work better. Power output is approximately 250 mW; more than sufficient output level from a solid-state signal tracer small enough to hide on the back of a speaker magnet.

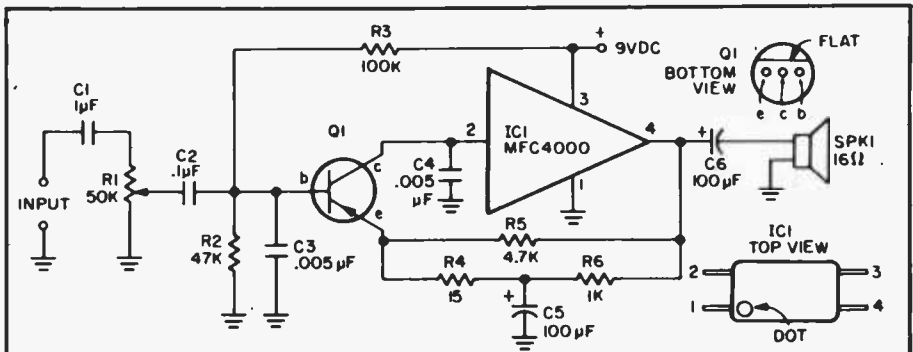

PARTS LIST FOR MIGHTY MITE SIGNAL TRACER

- C1—0.1-µF, 600 VDC capacitor (see text)
- C2—0.1-µF, 10 VDC capacitor
- C3, C4—.005-µF, 10 VDC capacitor
- C5—100-µF, 3 VDC capacitor
- C6—100-µF, 10 VDC capacitor (250 µF for better low-frequency response with large speakers)
- IC1—Motorola MFC-4000
- R1—Potentiometer, 50,000-ohms, audio taper resistor
- R2—47,000-ohms, ½-watt resistor
- R3—100,000-ohms, ½-watt resistor
- R4—15-ohms, ½-watt resistor
- R5—4,700-ohms, ½-watt resistor
- R6—1,000-ohms, ½-watt resistor
- Q1—PNP transistor, Radio Shack 276-2021
- SPK1—16-ohm speaker (see text)

IC12 100X Instrument Amp

□ When voltages drop too low to be indicated on your scope or VTVM, just connect our 100X Instrument Amplifier ahead of your test gear and you get full-screen or full-scale readings. With an input impedance of 1 megohm, and a flat frequency response from DC to 20 kHz and beyond, the 100X Instrument Amplifier provides a gain of exactly 100 when potentiometer R2's wiper is at the top (full gain).

Connected ahead of a VTVM, the 100X Instrument Amplifier will convert, for example, a 10 mV DC level into 1V. Here's a value that can be read on your VTVM! Similarly, if connected ahead of a scope's vertical input, the amp boosts a signal that will just cause a wiggle on the CRT to almost a full screen trace. The maximum input signal level for undistorted output is 100 mV peak-to-peak. Naturally, higher input signals

can be used because of the attenuation provided by sensitivity control R2.

After you've completed the 100X Instrument Amplifier, connect a VTVM across the output, adjust R4 for a zero DC meter reading. From time to time check the DC output; if it has drifted off zero, simply readjust R4. It might happen that changing R2's setting over a wide range might cause the output to drift off zero; if

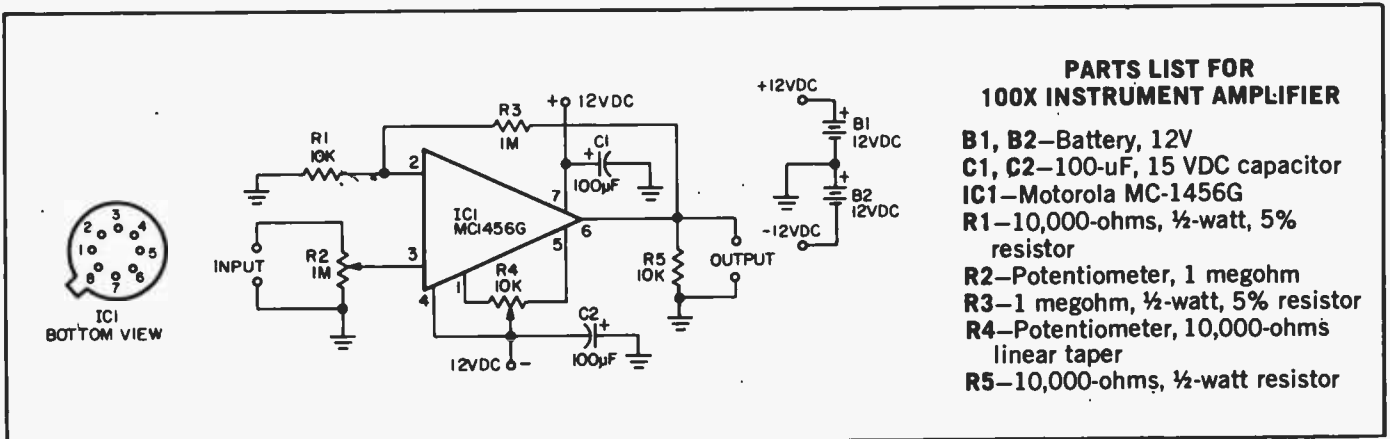

PARTS LIST FOR 100X INSTRUMENT AMPLIFIER

- B1, B2—Battery, 12V
- C1, C2—100-µF, 15 VDC capacitor
- IC1—Motorola MC-1456G
- R1—10,000-ohms, ½-watt, 5% resistor
- R2—Potentiometer, 1 megohm
- R3—1 megohm, ½-watt, 5% resistor
- R4—Potentiometer, 10,000-ohms linear taper
- R5—10,000-ohms, ½-watt resistor

so, simply readjust R4. If you are primarily concerned with AC mea-

surements, the output DC zero drift is unimportant, and a 0.1-µF capac-

itor can be connected between the 100X and your VTVM or scope.

IC13 C Booster

□ Suppose you needed a 10,000- μF capacitor; do you think it could squeeze on your project's printed circuit board? The answer is yes because it need be no larger than a transistor. By using a capacitance amplifier, the value of any capacitor can be boosted by a factor of 1000X. Capacitor C_x is the value to be boosted; the effective capacity appears at the terminals indicated C. If C_x is 10 μF the effective capacity that appears at the out-

put terminals is 1000 x 10 μF or 10,000 μF . Almost any capacity value can be used for C_x .

PARTS LIST FOR C BOOSTER

- C1—250-pF disc capacitor, 50 VDC or better
- IC1—SE537 Integrated Circuit (Signetics)
- R1, R3—10-megohm, ½-watt resistor
- R2—1000-ohm, ½-watt resistor

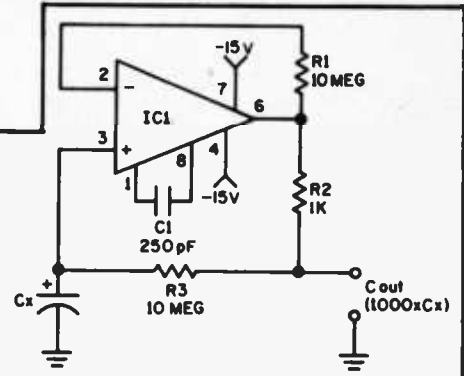

IC14 Notch Filter Oscillator

□ Every experimenter's spare parts box has the necessary components for our Notch Filter 1 kHz Oscillator. It's suitable for testing audio equipment, signal tracing or tape recorder bias adjustments. Integrated circuit IC1 can be just about any operational amplifier sold through "surplus dealers." The 1 kHz "notch filter" from the amplifier output to the inverting or negative (-) input determines the

output frequency. Notch Filter Oscillator's non-inverting or positive (+) input is grounded.

The power supply is bi-polar; use any voltage up to ± 15 VDC. While resistor R5 is not needed in many instances, its use insures your Notch Filter Oscillator project's success. Potentiometer R1 sets the output level; its maximum value will approach the total power supply volt-

age. If fine output control is desired, add potentiometer R6.

When your Notch Filter Oscillator is connected to a DC circuit, connect a DC blocking capacitor in series with R6's wiper arm. If the oscillator is to drive circuits of less than 10K ohm impedance, substitute a 1- μF non-polarized capacitor for C4, rated to the power supply's voltage.

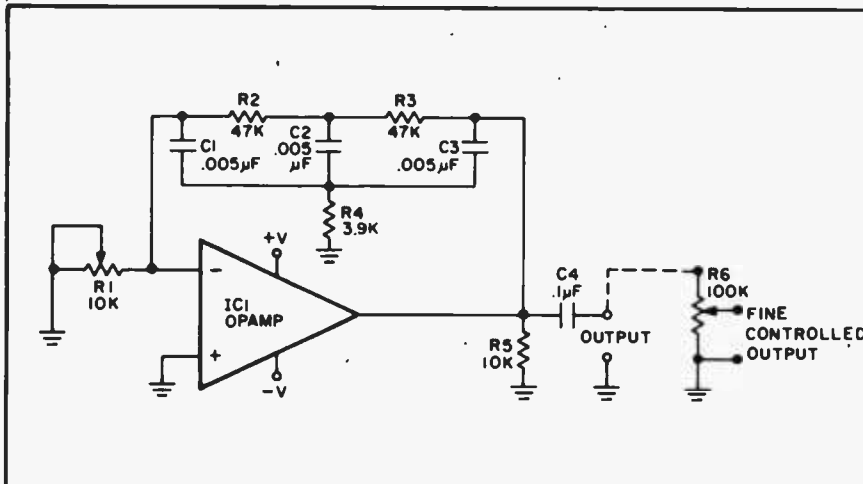

PARTS LIST FOR NOTCH FILTER OSCILLATOR

- C1, C2, C3—0.005- μF , 75 VDC capacitor
- C4—0.1- μF (see text) capacitor
- IC1—741-type operational amplifier
- R1—10,000 ohms pot
- R2, R3—47,000-ohms, ½-watt resistor
- R4—3,900-ohms, ½-watt resistor
- R5—10,000-ohms, ½-watt resistor (see text)
- R6—Potentiometer, 100,000-ohms, audio taper (see text)

IC15 Electric Butler Intercom

□ Using a miniature 1 watt IC power amplifier, our Electric Butler provides very high sensitivity and a loud, clean output. Wiring and layout is not critical as long as capacitors C4 and C5 are installed directly at IC1's terminals. Capacitor C6 can be as low as 100 μF if you want to cut costs and are willing to give up a little bass response. While S1 can be a standard

DPDT switch, a spring-return type will keep the Master station always monitoring the Remote.

The speakers can be any "intercom type" rated from 20 to 45 ohms. Though miniature 16 ohm speakers can be used, they do not have the power handling capacity of the "intercom" speaker. If there appears to be some high frequency instability, use

a shielded wire between S1 and R1; make a single-shield ground at R1.

If an AC power supply is used, it must be rated for at least 100 mA drain. If a battery supply is used, figure the 10 mA idling current; the batteries will be able to deliver the 100 mA maximum output peak current. Solder a 1 inch square tin heat sink to IC1's tab during construction.

PARTS LIST FOR ELECTRIC BUTLER INTERCOM

- C1—0.2- μ F, 3 VDC capacitor
- C2—0.02- μ F, 3 VDC capacitor
- C3—100- μ F, 25 VDC capacitor
- C4—0.05- μ F, 75 VDC capacitor
- C5—0.001- μ F, 10 VDC capacitor
- C6—200- μ F, 25 VDC capacitor (see text)
- IC1—General Electric PA-234
- Q1—NPN transistor 2N3391 (HEP 726)
- R1—Potentiometer, 5,000-ohms, audio taper resistor
- R2—2.2 megohms, $\frac{1}{2}$ -watt resistor
- R3—22,000-ohms, $\frac{1}{2}$ -watt resistor
- R4, R6—100,000-ohms, $\frac{1}{2}$ -watt

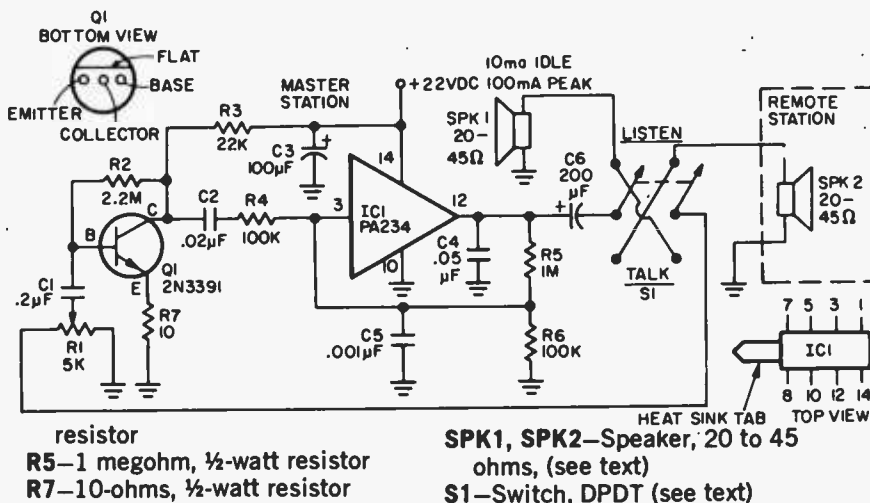

- R5—1 megohm, $\frac{1}{2}$ -watt resistor
- R7—10-ohms, $\frac{1}{2}$ -watt resistor

- SPK1, SPK2—Speaker, 20 to 45 ohms, (see text)
- S1—Switch, DPDT (see text)

IC16 Ultimate Talk Power

□ Operating directly from microphone level and providing a nominal 1V output, this compressor delivers 20 dB of compression (essentially distortion-free limiting) and will give ultimate talk-power to P.A. systems and ham or CB transmitters. Fact is, some sideband transmitters might not be able to handle the almost continuous "peak power" output of our compressor!

The only restriction on its use is that the microphone, DM1, must be the dynamic type: any impedance from 50 to 50,000 ohms will work. If DM1 can be permanently connected to the circuit, components R2 and C3 can be eliminated. But they must be used if there is any possibility DM1 will be disconnected. No substitution can be made for transistor Q1.

Capacitors C6 and C8 must be installed directly at the IC terminals for instability suppression. Capacitors C5 and C9 can be installed anywhere that's convenient. A bi-polar 12V supply (well filtered) is required. Power can be provided by batteries

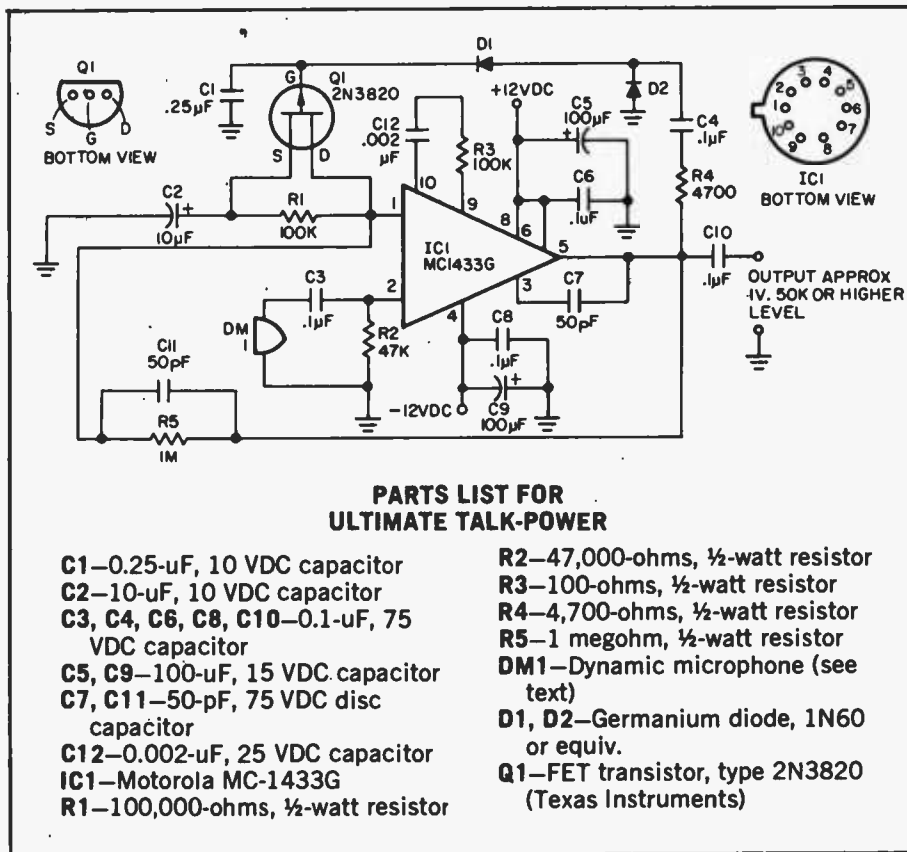

PARTS LIST FOR ULTIMATE TALK-POWER

- C1—0.25- μ F, 10 VDC capacitor
- C2—10- μ F, 10 VDC capacitor
- C3, C4, C6, C8, C10—0.1- μ F, 75 VDC capacitor
- C5, C9—100- μ F, 15 VDC capacitor
- C7, C11—50-pF, 75 VDC disc capacitor
- C12—0.002- μ F, 25 VDC capacitor
- IC1—Motorola MC-1433G
- R1—100,000-ohms, $\frac{1}{2}$ -watt resistor
- R2—47,000-ohms, $\frac{1}{2}$ -watt resistor
- R3—100-ohms, $\frac{1}{2}$ -watt resistor
- R4—4,700-ohms, $\frac{1}{2}$ -watt resistor
- R5—1 megohm, $\frac{1}{2}$ -watt resistor
- DM1—Dynamic microphone (see text)
- D1, D2—Germanium diode, 1N60 or equiv.
- Q1—FET transistor, type 2N3820 (Texas Instruments)

(for total hum-free operation) because the current requirement is ap-

proximately 15 mA. Any gain controls must come after the output at C10.

IC17 Tape Head Preamp

□ Is it worth about \$20 to have another tape or cassette player? From time to time surplus dealers offer complete tape or cassette mechanisms—everything ready-to-go except for

the electronics, and at rock-bottom prices of \$10, \$15 or \$20. All the mechanism needs is this equalized tape head preamplifier. Though the power supply is rated at ± 15 VDC,

almost optimum results will be obtained with supply voltages as low as ± 7 VDC. Two ordinary 9-volt transistor radio batteries will power the preamp for many hours.

The op amp, IC1, is internally compensated and no special wiring practices are needed; the preamp can be built in just about any enclosure, though the connecting wire from the tape head should be shielded. R1 connects to the non-inverting (+) input of the IC, R2 between the output and the inverting (-) input. No pin connections are given because the IC is available in many different pin configurations.

PARTS LIST FOR TAPE HEAD PREAMP

- C1—22- μ F electrolytic capacitor, 25 VDC or better (Calectro A1-128)
- C2—0.005- μ F disc capacitor, 25 VDC or better
- C3—0.01- μ F disc capacitor, 25 VDC or better
- IC1—Type 741 op amp
- R1—100-ohms, $\frac{1}{2}$ -watt resistor
- R2—100,000-ohms, $\frac{1}{2}$ -watt resistor

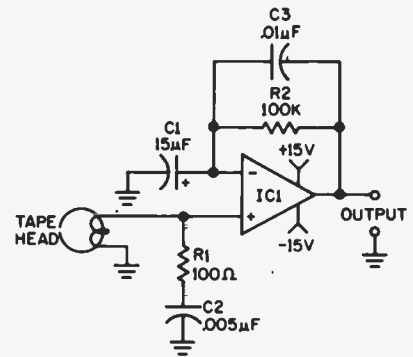

IC18 Stereo Balancer

By comparing the difference between channel outputs when feeding a mono signal, this differential stereo balancer meter allows you to set your stereo amplifier for precise electrical balance. Wiring is not critical; the circuitry can very easily be battery powered using a bi-polar battery connection as shown.

To use, set your stereo amplifier to mono—then adjust the balance control until meter M1 indicates a null (minimum reading). If you cannot obtain a null it indicates there is a phase reversal—which should be corrected—between the signal input and the speaker terminals. This circuit works on the differential principle. When an

amplifier is in perfect balance there is no difference in mono output voltage between channels. So our differential amplifier indicates zero difference on the meter.

PARTS LIST FOR STEREO BALANCER

- B1, B2—Battery, 9V, type 2U6
- C1—0.05- μ F, 50 VDC capacitor
- C2, C3—47- μ F, 50 VDC capacitor
- C4—50-pf, 100 VDC capacitor
- IC1—Motorola MC-1433P
- M1—VU meter (Calectro D1-958)
- R1, R2, R6—100,000-ohms, $\frac{1}{2}$ -watt resistor
- R3, R4—10,000-ohms, $\frac{1}{2}$ -watt resistor
- R5—10-ohms, $\frac{1}{2}$ -watt resistor
- R7—3,600 ohms (usually with VU meter) resistor

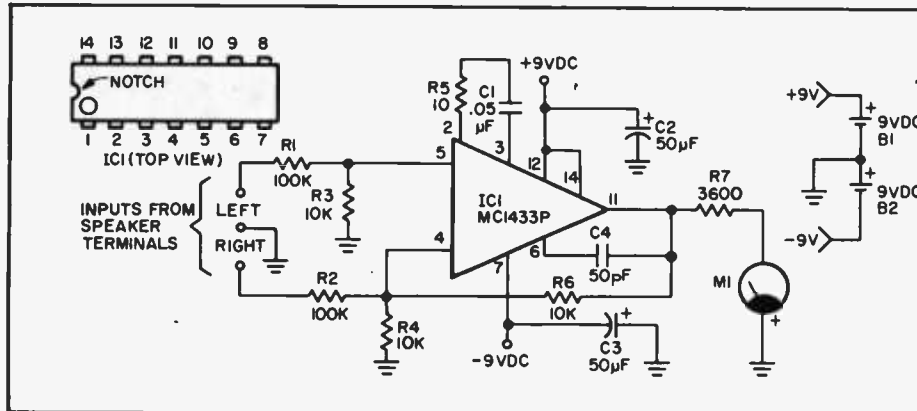

IC19 The Basic Amplifier

This general purpose amplifier features a power gain of 100 (20dB) and can be used as a preamplifier for a microphone, receiver, signal tracer, etc. The IC is internally compensated, providing stable performance with a flat frequency response to about 10 kHz with a gradual roll-off to 20 kHz. The overall gain can be reduced to 10 by increasing the value of R2 to 100,000-ohms. IC1 is available in several different packages; use the one most convenient for your particular component layout. R3 connects to the

PARTS LIST FOR THE BASIC AMPLIFIER

- C1—0.1- μ F Mylar capacitor, 25 VDC
- IC1—Type 741 operational amplifier
- R1, R3—1 megohm, $\frac{1}{2}$ -watt resistor
- R2—10,000-ohm, $\frac{1}{2}$ -watt resistor, (see text)

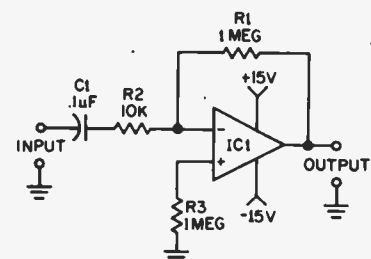

non-inverting (+) input of the IC, R1 between the output and the inverting (-) input. No pin connections

are given because the IC is available in many different configurations.

IC20 Versatile Hi-Pass Filter

□ A high pass filter is a handy device to have around. Depending on the corner (turnover) frequency you select it can serve as a hum filter, distortion meter or highly-selective audio equalizer. The values of C1, C2, C3 and R1 provide a corner frequency of 1000 Hz. The IC has internal compensation so special wiring techniques are unnecessary. No pin connections are given because the 741 IC is available in many different pin configurations. Check the manufacturer's specs for the particular IC

used. R2 connects to the non-inverting (+) input of the IC, R1 between

the output and the inverting (-) input.

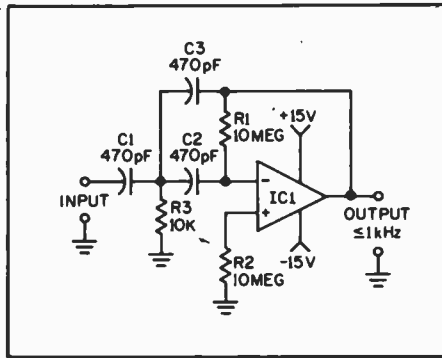

PARTS LIST FOR VERSATILE HI-PASS FILTER

- C1, C2, C3—470-pF, disc capacitor, 50 VDC or better
- IC1—741-type operational amplifier
- R1, R2—10 megohms, ½-watt resistor
- R3—10,000-ohms, ½-watt resistor

IC21 Cigar-Size Amplifier

□ Using an IC no larger than a fly, Cigar-Size Amplifier delivers almost 250 mW into a 16-ohm speaker. A 50 mV input signal coming from a source whose output impedance is 1000 ohms or lower is required for maximum output. The power supply

can be a 9 volt type 2U6 battery; the idling current is no higher than 6 mA. Best way to keep things small is to use a printed circuit board assembly or a mini-mount as shown.

Cigar-size amplifier can serve as a general utility amplifier for checking

out low-level audio projects, or it can serve as a monitoring amplifier for tape and cassette decks.

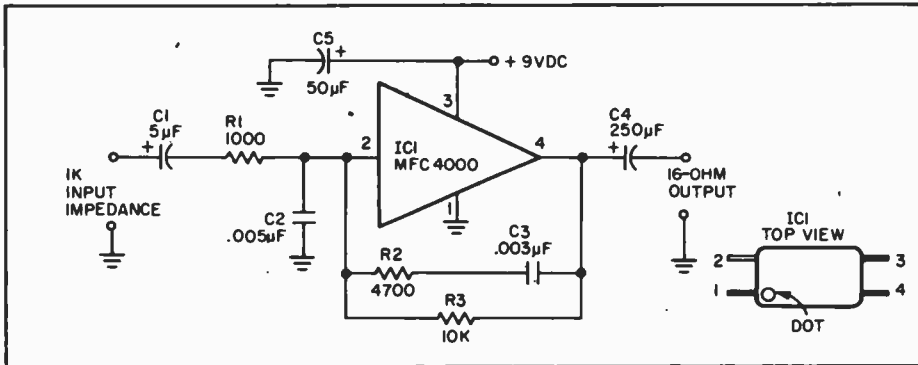

PARTS LIST FOR CIGAR-SIZE AMPLIFIER

- C1—5-µF, 10 VDC capacitor
- C2—0.005-µF, 10 VDC capacitor
- C3—0.003-µF, 10 VDC capacitor
- C4—250-µF, 10 VDC capacitor
- C5—50-µF, 10 VDC capacitor
- IC1—Motorola MFC 4000
- R1—1,000-ohms, ½-watt resistor
- R2—4,700-ohms, ½-watt resistor
- R3—10,000-ohms, ½-watt resistor

IC22 Protect-A-Volt

□ A simple turn of a knob sets Protect-a-Volt's output voltage anywhere in the 3 to 20-volt range—and with

full short circuit protection! Should there be a wiring error in the powered project, this supply automatically

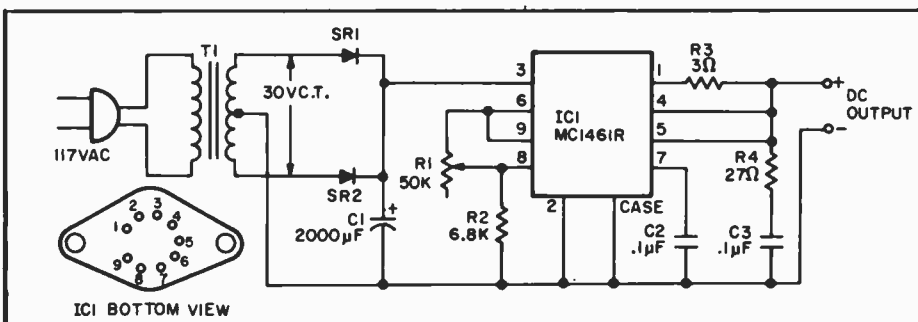

PARTS LIST FOR PROTECT-A-VOLT

- C1—2000-µF, 25 VDC capacitor (see text)
- C2, C3—0.1-µF, 75 VDC disc or Mylar capacitor
- IC1—Motorola MC-1461R
- R1—50,000-ohms pot
- R2—6,800-ohms, ½-watt resistor
- R3—3-ohms, ½-watt resistor
- R4—27-ohms, ½-watt resistor
- SR1, SR2—Silicon rectifier, 50 PIV, 1A
- T1—Power transformer; 117 VAC primary, 30 VC.T.: 200 mA secondary (see text)

shuts down the output voltage until the overload is removed. The maximum output current (short circuit protection) has been established by resistor R3's value to 200 mA. Power transformer T1's rating should not exceed 200 mA as extra current capacity could not be handled by the

integrated circuit.

To make this project easy to build, and to sharply reduce total cost, it was necessary to eliminate a fully off, or zero output, setting for Voltage Adjust control R1. The minimum output voltage is 3V. The maximum voltage from T1's secondary must be

30V rms if the secondary is center-tapped; 15V rms if there is no center-tap and a bridge-rectifier is substituted for silicon rectifiers SR1 and SR2. Capacitor C1's voltage rating must be 25 volts minimum. Do not eliminate high-frequency-compensation network components R4/C3.

IC23 Hi-Level 4-Channel Mixer

□ Best signal to noise ratio in a microphone mixer is always obtained if amplification is provided ahead of the loss in the mixer network. You can easily put this idea to work with our mixer—a full-fidelity, professional-grade microphone mixer that contains four independent amplifiers within the integrated circuit.

For simplification, our schematic shows only the connections for one of the four amplifiers; the others are identical to the first.

Note that the power supply is a single-ended 12 VDC (negative grounded); it must be well filtered, or, use a battery supply. The current requirements are approximately 30 mA total. The power supply is internally connected to the amplifiers.

To prevent high frequency oscillation, components C3, R2 and C5 must be installed directly at the IC's terminals.

Any 50 to 50,000 ohm dynamic microphone can be used. However, crystal and ceramic mikes won't work with Pro-Mix; the medium imped-

ance IC's medium input impedance will excessively load down a high im-

pedance mike, resulting in sharp, low-frequency attenuation.

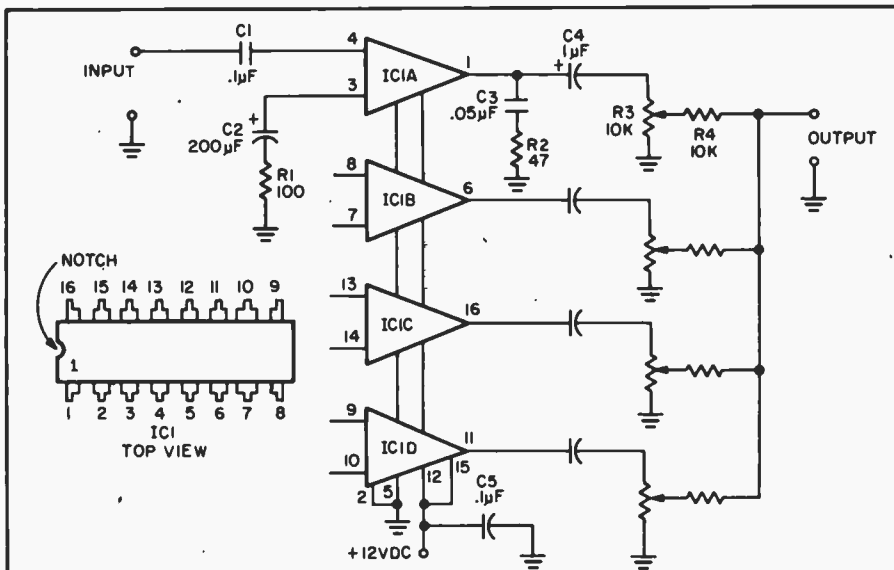

PARTS LIST FOR HI-LEVEL MIXER

- C1—0.1-µF, 3 VDC capacitor
- C2—200-µF, 3 VDC capacitor
- C3—0.05-µF, 75 VDC disc capacitor
- C4—1-µF, 15 VDC capacitor
- C5—0.1-µF, 15 VDC capacitor

IC1—RCA CA 3052

- R1—100-ohms, ½-watt resistor
- R2—47-ohms, ½-watt resistor
- R3—Potentiometer, 10,000-ohms audio taper
- R4—10,000-ohms, ½-watt resistor

IC24 SCA Adaptor

□ This simple but very effective SCA Adaptor can be assembled on a section of perfboard about 2-in. x 3-in.

in size. All components should be firmly soldered to push-in terminals.

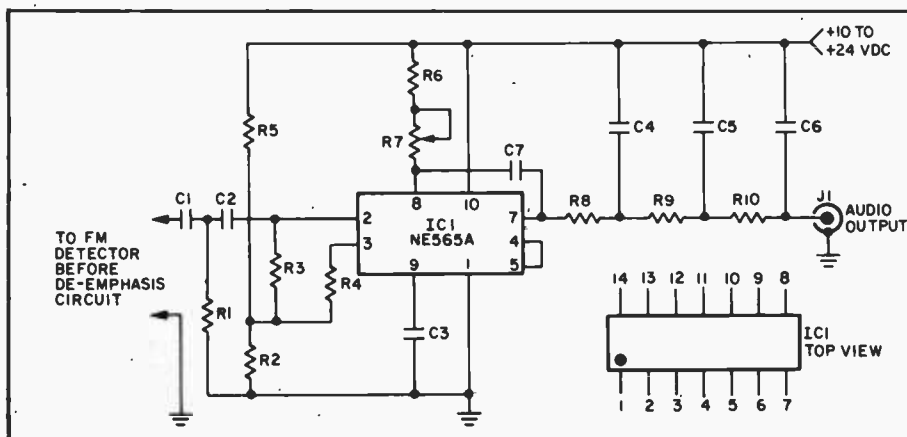

PARTS LIST FOR THE SCA ADAPTOR

- C1, C2—510-pF, 500 VDC ceramic disc capacitor
- C3, C7—0.001-µF, 75 V Mylar capacitor
- C4, C6—0.018-µF, 500 VDC ceramic disc or Mylar capacitor
- C5—0.047-µF, 75 VDC Mylar capacitor
- IC1—Signetics NE565A
- J1—Phono jack
- R1, R2, R3, R4—4700-ohm, ½-watt resistor
- R5—10,000-ohm, ½-watt resistor
- R6—1800-ohm, ½-watt resistor
- R7—5000-ohm potentiometer
- R8, R9, R10—1000-ohm, ½-watt resistor

The input *must* connect to the FM receiver's detector output before the de-emphasis network. The SCA output at J1 can be connected to any relatively high-gain amplifier—the output level is about equal to that of a crystal microphone.

The FM receiver must be tuned to a station you know has SCA programming. Then adjust potentiometer R7 for a clean SCA audio output. Potentiometer R7's adjustment is not critical—the subcarrier is pulled in when R7's adjustment is near the

correct setting. A metal cabinet is suggested. If desired, a *pre* de-emphasis output jack can be installed on the FM receiver or tuner so that the normal (after de-emphasis) output can feed the hi-fi system independent of the SCA output.

IC25 Stereo Mike Preamp

□ A dual IC gives hi-fi amplification for a stereo microphone pair. Low distortion and full-fidelity frequency response characterize this mike preamp. With resistors R1 and R2 providing a center-tap for the power supply, the IC can be powered from a standard single-ended power supply, or series connected batteries.

Be very careful to observe the cor-

rect polarity for capacitors C2 and C3. In the event the unit motorboats (low frequency oscillation), install a 0.1 uF capacitor from pin 14 to ground.

The connections for one of the two amplifiers is shown circled; the connections for the second amplifier are uncircled. Pins 7 and 14 are common to both amplifiers. Capacitor Cx's

value is determined by the load impedance. It should be of such value as to provide the desired overall low frequency response; 0.1 uF is suggested for high impedance output loads (100K and higher), while 10 uF is suggested for low impedance loads.

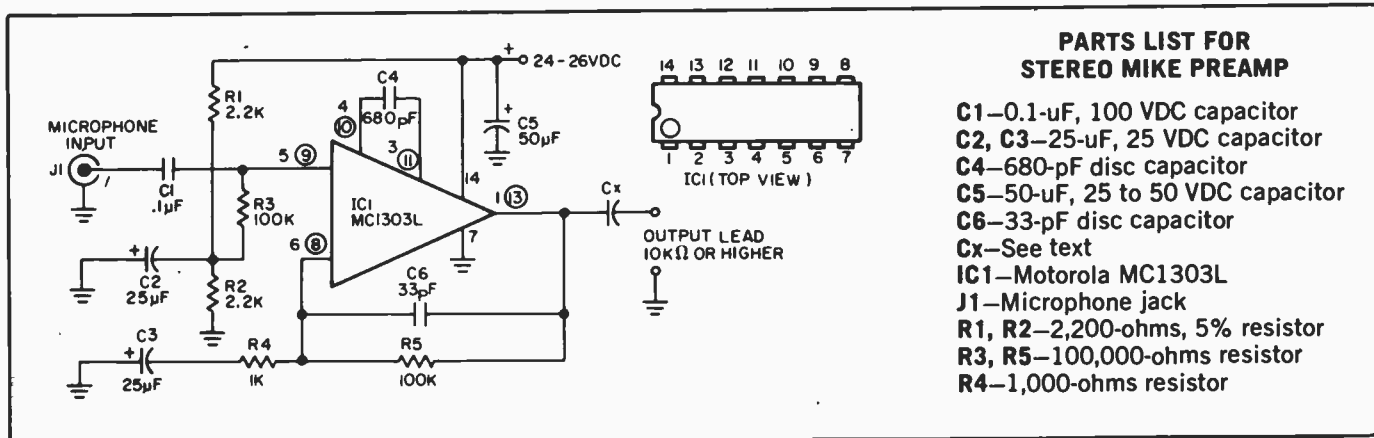

PARTS LIST FOR STEREO MIKE PREAMP

- C1—0.1-uF, 100 VDC capacitor
- C2, C3—25-uF, 25 VDC capacitor
- C4—680-pF disc capacitor
- C5—50-uF, 25 to 50 VDC capacitor
- C6—33-pF disc capacitor
- Cx—See text
- IC1—Motorola MC1303L
- J1—Microphone jack
- R1, R2—2,200-ohms, 5% resistor
- R3, R5—100,000-ohms resistor
- R4—1,000-ohms resistor

IC26 Comm-Press Log Amp

□ A log amplifier is a device that takes a large change in input signal and converts it to a small change in output. Hook one into a communications system and both low and loud sounds come out at almost the same level giving you a lot more talk power; it sounds just like the hard-sell commercials on TV. The input level should be about 0.1 volt peak for an

output voltage of about 1 volt peak.

Since this is a high frequency device, lead dress and good power supply bypassing at the power supply terminals are required. Keep the ground leads short. If a microphone preamplifier is used before the log amplifier, connect a volume control before the log amp's input.

Some experimentation will be

needed for optimum P.A. operation. Because of the much higher average voice power, a P.A. system using a log amp compressor might appear to be more sensitive to acoustic feedback (howling). Actually, you will have much more voice output before the howling starts.

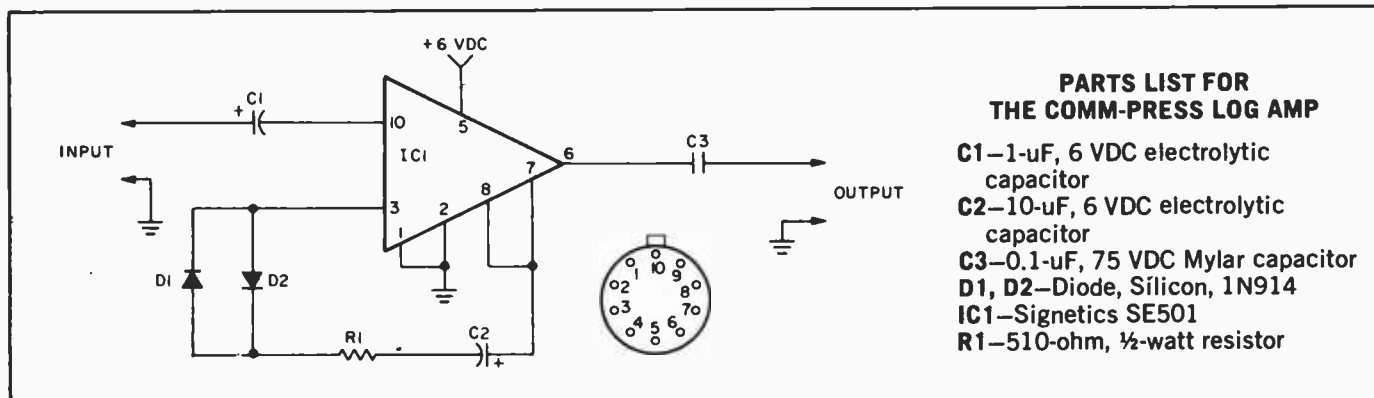

PARTS LIST FOR THE COMM-PRESS LOG AMP

- C1—1-uF, 6 VDC electrolytic capacitor
- C2—10-uF, 6 VDC electrolytic capacitor
- C3—0.1-uF, 75 VDC Mylar capacitor
- D1, D2—Diode, Silicon, 1N914
- IC1—Signetics SE501
- R1—510-ohm, 1/2-watt resistor

IC27 Porta-Groove Amp

Just add a battery-powered motor to our Porta-Groove Amp, and you've made a portable phonograph of considerably better quality than you can buy. Phono pickup X1 must be the ceramic type—either the usual high impedance or so-called low impedance (actually several thousand ohms) ceramic type can be used.

Transformer T1 should have a primary impedance anywhere from 150 to 300 ohms center-tapped. The secondary should match the speaker impedance. Do not use a sub-miniature T1; for good sound quality T1 must have sufficient "iron," so make certain it can handle approximately 25 mA average current.

A 6-inch speaker will deliver remarkably good sound quality, at least the equal of a good quality table radio. Two 6V lantern batteries or eight D cells easy give Porta-Groove Amp enough oomph. Do not use C or AA cells; they cannot give even reasonable life with the 20 mA idling drain, 140 mA peak power drain.

PARTS LIST FOR PORTA-GROOVE AMP

- C1, C2, C4—5- μ F, 6 VDC
- C3—0.01- μ F, 10 VDC
- C5—50- μ F, 15 VDC
- C6—.005- μ F, 15 VDC
- R1—Potentiometer, 1 megohm audio taper
- R2—470,000-ohms, 1/2-watt resistor
- R3—Potentiometer, 3 megohms
- R4—510,000-ohms, 1/2-watt resistor
- R5—1,000-ohms, 1/2-watt resistor
- SPK1—Speaker, 3.2, 4 or 6-8 ohms
- T1—Output transformer, 150 to 300

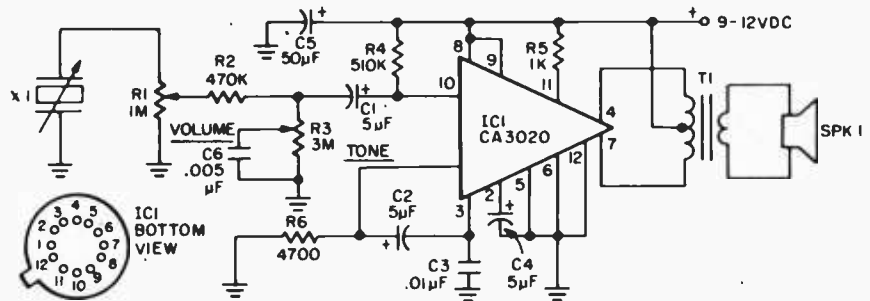

ohms center-tapped primary coil to speaker impedance (see text) (Calectro D1-729 or equiv.)

IC1—RCA CA3020 or CA3020A
X1—Ceramic phono pickup (see text—Calectro S2-288 or equiv.)

IC28 Record Remote Amplifier

Here's a professional performance record remote amplifier suitable for the hobbyist, amateur recordist or professional broadcast engineer. The input is any microphone with an output impedance up to 50,000 ohms, or for professional use, the input can be at line level. Output is 500-ohms at line level with a built-in VU meter indicating output level. When the distance between the remote amplifier

and its associated equipment is less than 25 feet the amplifier can be connected to any hi-fi type, high impedance input (10,000-ohms or higher).

For long line or professional applications, connect a 500/500 line matching transformer to output jack J2. Capacitor C4 is 0.1 μ F for all applications except when used with a line matching transformer. When a transformer is used C4 is 25 μ F. Bet-

ter results can be obtained with a line matching transformer if the transformer primary replaces R4 (eliminating C4).

M1 is a standard VU meter whose internal rectifier has been removed (open the case and unsolder the rectifier). Total current drain is less than 5 mA and the bi-polar power supply can consist of two transistor radio type 9-volt batteries.

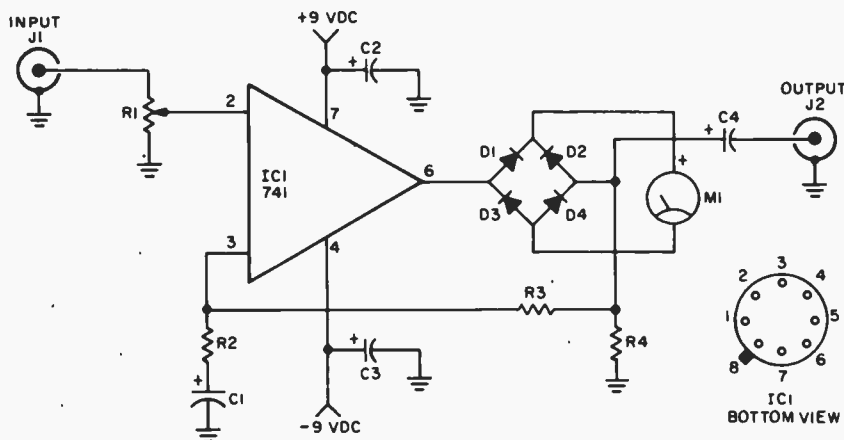

PARTS LIST FOR RECORD REMOTE AMPLIFIER

- C1—220- μ F, 12 VDC electrolytic capacitor
- C2, C3—47- μ F, 50 VDC electrolytic capacitor
- C4—0.1- μ F or 25- μ F, 12 VDC capacitor (see text)
- D1, D2, D3, D4—1N60
- IC1—Type 741 operational amplifier
- J1, J2—Shielded jacks
- M1—VU meter with internal rectifier removed (Calectro D1-930 or equiv.)
- R1—50,000-ohm audio taper potentiometer
- R2—100-ohm, 1/2-watt resistor
- R3—15,000-ohm, 1/2-watt resistor
- R4—560-ohm, 1/2-watt resistor

IC29 Far Out Gain Control

One of the problems of locating a volume control in a remote location is that of hum and noise pickup; as a general rule, the greater the wire length the greater the hum and noise picked up. With an electronic attenuator the entire problem is eliminated, for the volume control wires carry only a DC control voltage which causes an integrated circuit amplifier's gain to vary by as much as 90 dB. Hum and noise picked up in the DC control wires are not impressed on the amplified audio signal.

No layout precautions are required and any type of assembly can be used. If desired, the amplifier gain can be voltage controlled by eliminating po-

tentiometer R1 and applying 3.5 to 6 volts DC directly to pin 2. With 3.5 VDC the amplifier works at full gain. The attenuation increases to a maximum of 90 dB as the control voltage is increased to 6 VDC.

PARTS LIST FOR THE FAR OUT GAIN CONTROL

- C1—0.47- μ F, 25 VDC capacitor
- C2—50- μ F, 25 VDC capacitor
- C3—680-pF, 500 VDC ceramic disc capacitor
- C4—0.1- μ F, 75 VDC Mylar capacitor
- IC1—Motorola MFC 6040
- R1—50,000-ohm potentiometer

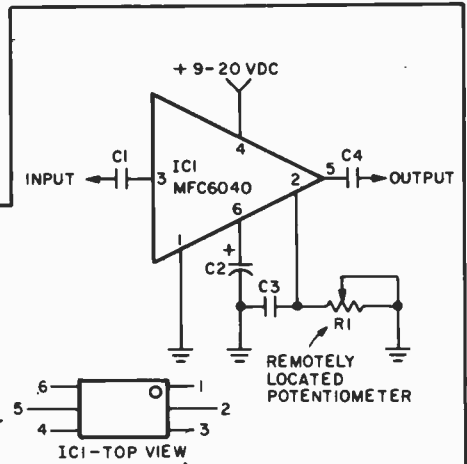

IC30 No-Noise Mike Preamp

Packing a walloping 60 dB gain with a 7 volt output, this mike preamp nevertheless is almost dead quiet. The input impedance is about 75,000-ohms; output impedance about 100-

ohms. Actual maximum output voltage depends upon the load resistance, ranging from 7 volts output into a 10,000-ohm load to 4 volts output into a 1000-ohm load. Parts layout is

not critical and any type of assembly can be used. The power supply current is approximately 8 mA, with a maximum of 12 mA.

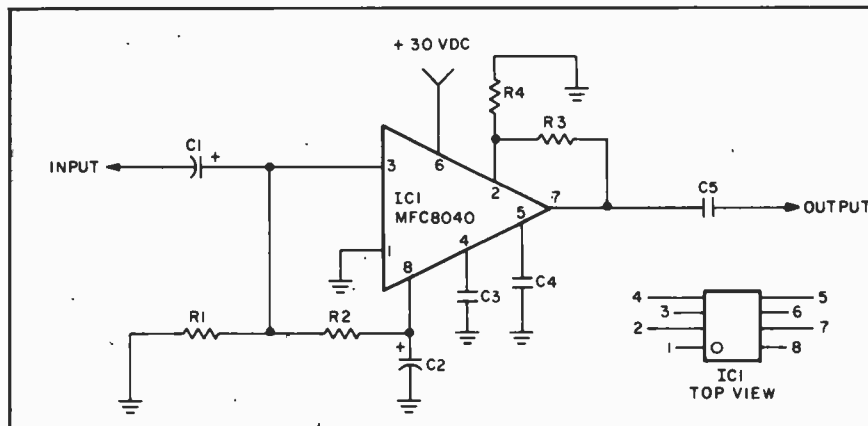

PARTS LIST FOR THE NO-NOISE MIKE PREAMP

- C1—2- μ F, 12 VDC electrolytic capacitor
- C2—100- μ F, 12 VDC electrolytic capacitor
- C3—0.047- μ F Mylar capacitor
- C4, C5—0.1- μ F Mylar capacitor
- IC1—Motorola MFC 8040
- R1—75,000-ohm, 1/2-watt resistor
- R2—270,000-ohm, 1/2-watt resistor
- R3—110,000-ohm, 1/2-watt resistor
- R4—100-ohm, 1/2-watt resistor

101 PROJECTS

(Continued from page 19)

more than gold, but you can get assortments of popular values at very reasonable prices. Don't hesitate to shop around for bargain assortments.

A good source of surplus switches, trimpots, panel lamps, LEDs and miscellaneous hardware are outfits like Poly-Paks, B&F Enterprises and John Meshna. You can often get two, three or four of anything for what you would pay for one at the local parts distributor.

Probably the best place to get parts is from old projects, and then they cost

you nothing. Never throw out an old project until you've stripped the valuable parts: the power transformer, potentiometers, switches, meters, jacks, mounting hardware, etc. These are the expensive items, the ones worth saving. But don't start salvaging resistors and small capacitors. They aren't worth the effort and they'll wear you down before you get to the valuable components. Go right for the more expensive components and then scrap the rest.

Finally, keep your eyes open for close-outs at your local parts distributor. Often, he will fill baskets with "dust collectors" priced pennies on the dollar just to get rid of them. For example, one distributor had old, pre-priced stock of electrolytic capacitors

he didn't think was worth remarking to the new price. So he dumped capacitors now selling for as high as \$2 each for "a quarter-a-piece, TAKE YOUR PICK." Another distributor changed the brand of potentiometers he handled and closed out the old stock at 50 cents each. Sometimes he'll have buys in power transformers, next time resistor assortments, maybe even solid-state devices and photocells. Anytime you spot a closeout that looks like something you might need for a future project stock up.

Plug In The Iron. Okay. We've given you tips on how to build and how to save on overall project cost. Now it's up to you. Start heating up the soldering iron. ■

MOD-X, THE SIMPLEST CLOCK YET

by Norman Myers



Take just 8 parts, and a couple of switches, connect this module to make an alarm clock in less than two hours.

□ Dozens of clock projects have been published in the past three or four years, and they all have two things in common: an integrated circuit which contains most of the counting and timing circuits for making a digital clock, and *lots* of wiring, especially between the integrated circuit chip and the read-out devices. These range from Numitron or other multisegment display tubes for each number to the more-recent, and easier, all-in-one, 7-segment LEDs which have four or six digits in one compact assembly.

Even with their maze of interconnecting wires many of these clocks offer only time, and (usually) an alarm. Some, but not all, permit you also to read the seconds as they elapse, and more and more have the Cat-nap (snooze) feature.

Now, thanks to today's improved methods of IC manufacture and mass-

production, which continue to bring prices down, down, down, National Semiconductor Corp. has brought out a *complete* clock-on-a-chip, including the readout display—the numbers which show the time. You no longer have to connect the outputs of the circuit chip which does the computations to the display digits, because the display and the clock chip are all on one small assembly, ready to build into a case and connect to a simple power supply, a couple of switches, and if you like, to an alarm.

If you want to add a couple more switches you can have a clock which displays the seconds, on command, or which includes the cat-nap (snooze) feature. Finally, if you want to add one more switch you can include the *hold* feature, which makes setting the clock a bit faster. The wiring for these extra features is shown in the spec sheet

which comes with the clock module. This module is made in several versions by National, depending on whether the clock is intended for use in 50 Hz or 60 Hz countries, and on whether or not it's intended to display 24-hour or 12-hour time.

In addition to these features, this clock can tell you if there's been a power failure. To tell you that the time it shows is incorrect it flashes on and off once every second until you stop it. When it's telling time the colon between the hours and the minutes numbers flashes once every second. Chip-X also tells you whether it's AM or PM. It does this by showing a dot in the upper left hand corner in the PM. Finally, when the alarm is set to go off, a period at the lower right is lit. Press the alarm button to be sure the alarm is enabled (ready). put S4 on *Alarm*, and go to sleep. After the alarm goes off, touch

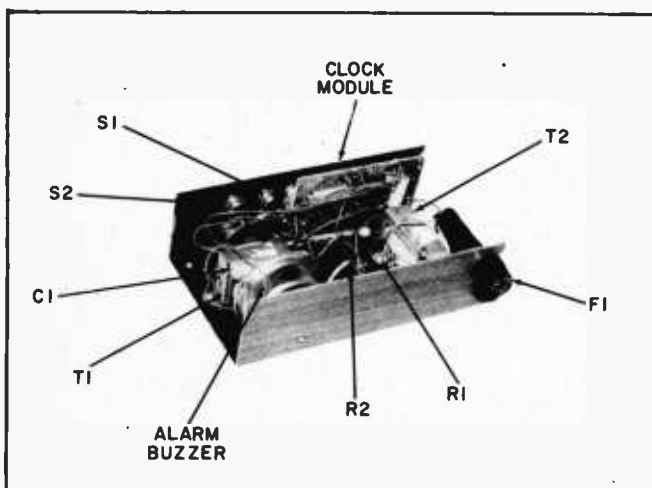
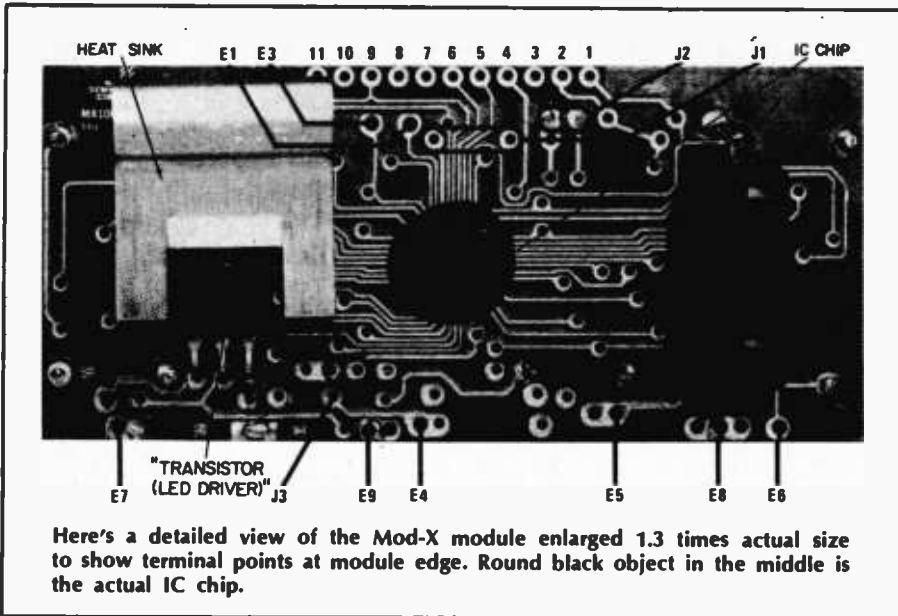

Photo at left shows placement of parts in author's clock. Placement is entirely uncritical and you can use any convenient arrangement, depending on the space you have in the case you select. Picture above shows the actual module. Mod-X has six 7-segment LED numerals (they all look like eights here since no segments are lit up). Connections to the module are made via the 11 terminals (holes) in the bottom edge of the board, plus a few others at the top.

Mod-X Clock



Here's a detailed view of the Mod-X module enlarged 1.3 times actual size to show terminal points at module edge. Round black object in the middle is the actual IC chip.

find that the back is best because it makes mounting of the module very simple. Be sure to check the soldered connections. The solder balls should only be on their own connection points and not short-circuited to any printed circuit wires.

More on Construction. Note on the schematic that transformers T1 and T2

have their primary leads marked a and b, and the secondary leads marked A and B. The leads are not actually marked this way on the transformer itself, but I have designated them this way for the project. As shown on the schematic, if you look down on the top of the transformers, with primary to the left and secondary to the right, the

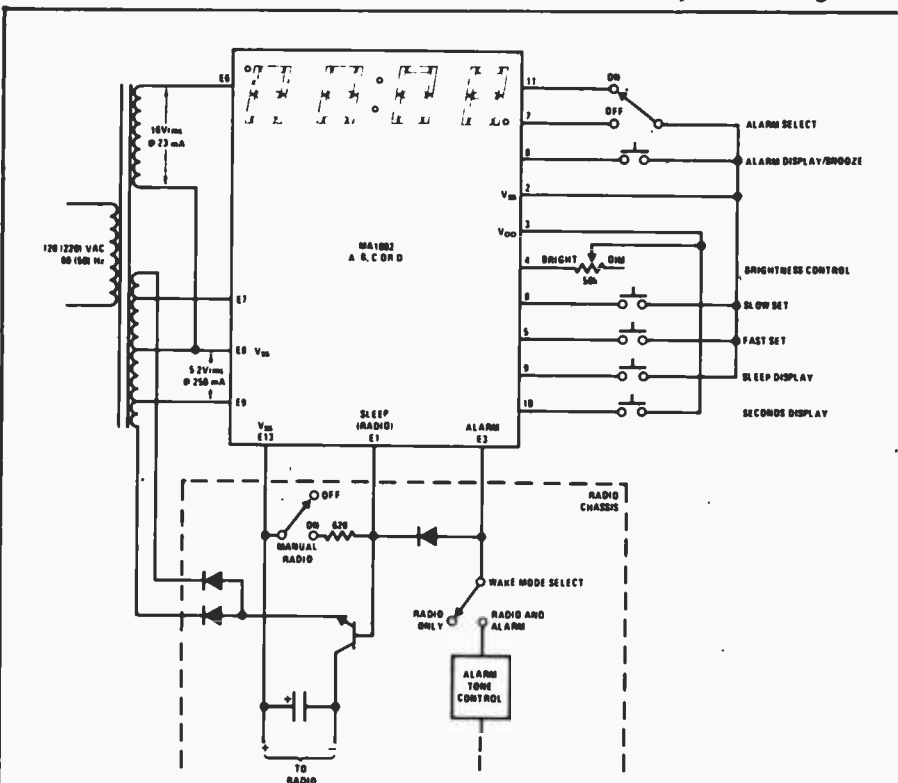
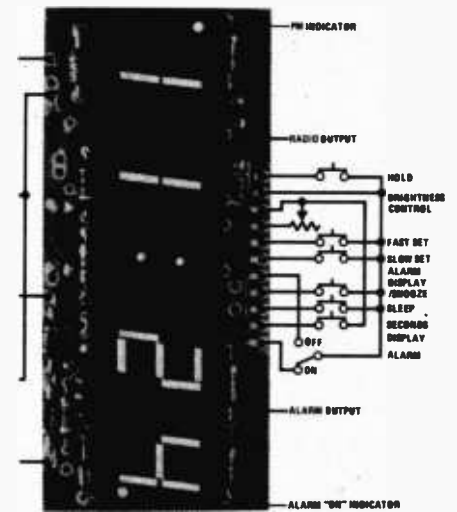

Diagram above is one supplied by National Semiconductor showing optional features you can add if you want more functions—just by adding switches to circuit. Transformer is special, made for clock manufacturers. It's easy to replace this, as the author has, with two small Radio Shack transformers. Transistor at bottom of diagram, with base connected to terminal E1 is used as switch, to turn external radio On or Off. Diodes to its left are rectifiers for radio's power supply.

"a" and "A" leads will be towards your hair and the "b" and "B" leads will be toward your chin. Follow the schematic when connecting these leads. Also, do not forget to use a heat sink when soldering to transistor Q1. Finally (important!) watch out for tricky S4. Most DPDT switches, including the ones on the parts list, are "backwards." When the toggle is up, the *bottom* contacts are engaged. So watch how you do the wiring and labeling of the switch, or you will be confused, later on.

Testing. Your clock should work well the first time you try it—so before you plug it in go through the thing everybody hates: Check and double check your wiring. If the display fails to light, you have probably forgotten to connect pin 3 on the clock module to pin 4. The voltage (AC) between E6 and E8 on the module should be about 15 volts. The DC voltage reading between E8 (positive) and E7 (negative) should be about 5 volts. If these voltages are not correct, check out T1 and T2 to see if they have AC output voltage coming from their secondaries when disconnected from the circuit. If the clock portion works but the buzzer will not sound, check E3 to see if the voltage at



Additional optional functions diagrammed at left in schematic are shown above connected to the module.

that point goes high relative to E7 when the alarm is supposed to go off. Do not be tricked by the AM/PM capability of this clock when checking the alarm. If your clock is set to go off at 6:00 AM, do not expect it to go off at 6:00 PM when testing it. Pay attention to the little AM/PM dot in the upper left corner.

National makes eight different modules in the MA 1002A through E series. Be sure you use only the one with "A" when you're building *this* project. ■

POWER ANTIQUES FROM AN AC-BATTERY

by James A. Fred

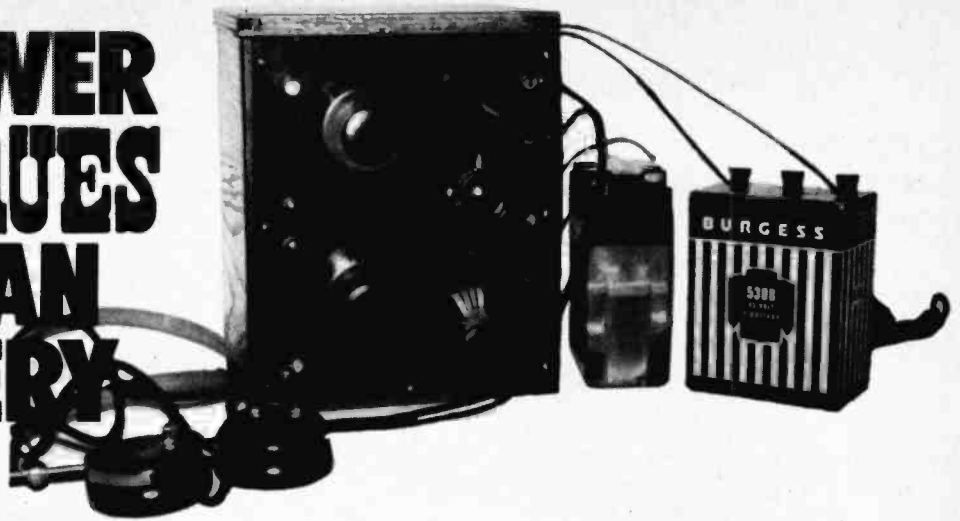

Authentic-looking B battery for tube plates and filaments from the AC line.

□ It always "bugs" me to see an antique radio receiver with an old pair of headphones or a horn speaker being powered by a power supply in a gray hammertone box. Some collectors have built power supplies into a wooden cabinet which is a copy of an old radio cabinet. Why not go one step further and use an actual B battery wrapper to enclose a power supply?

With this idea in mind I built two power supplies, one a combined A & B supply (A batteries power tube filaments, and B batteries power the plate circuits.) and two, just a 22½ and 45 volt DC supply. In order to keep the supplies as small as possible I used the wrappers from a Burgess 5308 (45 volts tapped at 22½ volts) 5 inches high by 4 inches wide by 2½ inches deep. I had found three dead batteries in an industrial plant where they had been used in a high resistance bridge. You may have to modify your supply if you can't find batteries of this size or larger.

The combined power supply delivers 3.3 volts regulated, for the filament of a 199 tube, and 45 volts, Zener-diode regulated, for the B voltage. This supply powers a one-tube regenerative receiver, an Ace model V manufactured by Powel Crosley. The other supply delivers 22½ volts and 45 volts. It is used with a Clapp-Eastham regenerative receiver, which has one 201A tube. A 6-volt storage battery supplies the filament power.

Because you may not be able to find exactly the same batteries that I did I will tell you how to build an electrical equivalent that you can put into a box of your choice.

They're Designed This Way. Both supplies start out alike with a line cord and a 5PST slide switch. Next comes a transformer supplying 125 volts and 6.3 volts AC at 0.6 amperes. If you are building the combination supply use both windings, otherwise you will only need the 125-volt secondary winding.

From here on we will describe the supplies separately.

For the combination supply full-wave bridge rectifiers, encased in plastic, are used. They are small, easily mounted, and have ratings in excess of what we need. The Zener diodes are rated at one watt. This supply uses a phenolic board with terminals staked into place, with the components wired point-to-point. You can use any construction you are familiar with, because parts placement is certainly uncritical.

About the Zener. The other supply uses parts similar to the one described above—full-wave bridge rectifier, large filter capacitors, and Zener diodes to regulate the output voltages.

One word of caution, if you have never used Zener diodes before. Zener diodes come with tolerances of ±5%, ±10%, and ±20%. This means that if you buy a 22½ volt Zener the regulated voltage can vary by 10%, 20%, or 40%. The prices vary inversely as

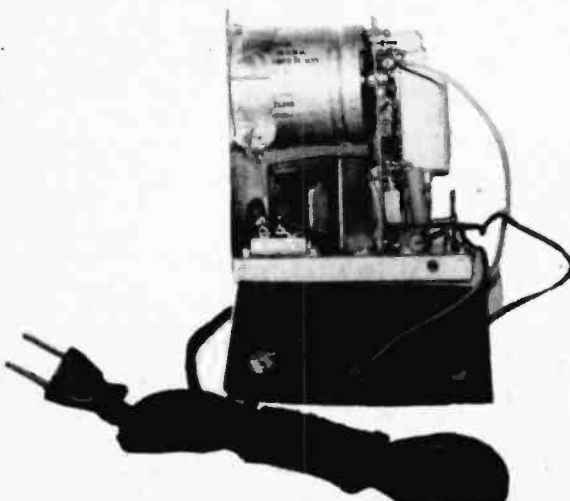

Author packed the components for A and B eliminators into old B case this way. Photo at top of page shows one tube Clapp-Eastham regenerative set with 6V motorcycle-A, and all-electric-B batteries.

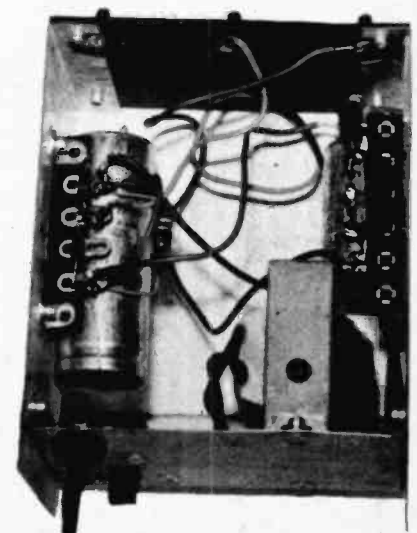

If you build only the B "battery" you'll have plenty of room inside.

Power Antiques

the tolerance, i.e., $\pm 5\%$ Zeners are the most expensive while $\pm 20\%$ are the cheapest. If you want the closest regulation buy $\pm 5\%$ otherwise the output voltages may vary considerably.

Take the usual precautions when soldering—use only rosin core solder, and use a heat sink when soldering semiconductors. As you can see from the photographs, galvanized steel was used because it is easily obtainable and it doesn't show in the finished unit. Pop rivets were used to hold the sheet metal together because the heads do not project like machine screws.

When the power supply is completed use your voltmeter to measure the output voltages before connecting to your radio. A carefully-built power supply will give you many hours of listening pleasure and will be well worth the time and money invested.

Figuring Component Values. Here's how to figure the size of current-limiting resistors R1, R2, and R3.

The secret of the Zener diode voltage-regulating circuit is the current-limiting resistor. To figure the size of this resistor you must know the voltage output of the bridge rectifier, the load current drawn from the power supply, and the voltage needed at the output of the supply. Connect the power supply to the line and measure the voltage at point X, with the balance of the circuit disconnected. You choose the output voltage yourself. Derive your chosen voltage from the voltage measured at X.

From a tube manual determine the load current your supply must deliver. This is determined by the tubes in your receiver. Remember, with a Zener diode

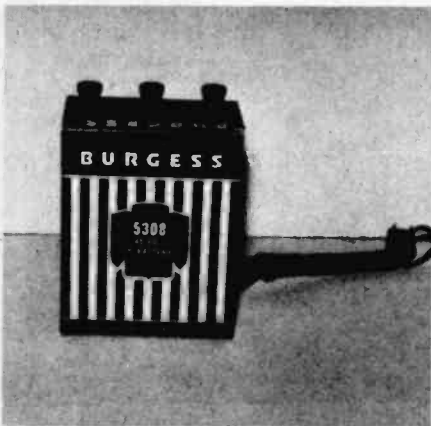

Whether you build the A "battery" only, or the A-and-B "battery," they'll look like this if you can locate an old case.

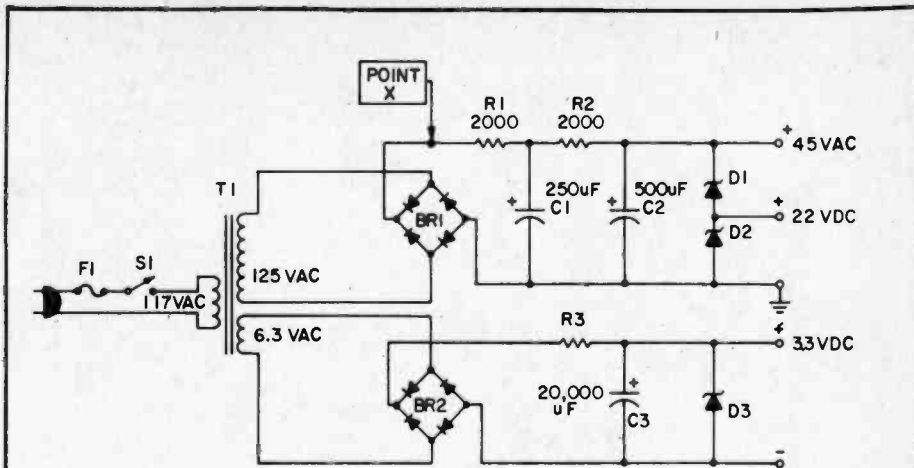

PARTS LIST FOR THE ALL-ELECTRIC B BATTERY

BR1—Bridge rectifier, 50 PIV

BR2—Bridge rectifier, 200 PIV

C1—250-uF, 75-VDC electrolytic capacitor (obtainable from local radio-TV parts distributor)

C2—500-uF, 50-VDC electrolytic capacitor (from parts distributor)

C3—20,000-uF, 20-VDC electrolytic capacitor (Allied Radio number 852-0871)

Note: All capacitors in this circuit are approximate values. Any higher voltages and/or higher capacitances are acceptable, but may take up somewhat more space.

R1, 2—2000-ohm, 3-watt resistors (Allied Radio number 880-5334 or equiv.) Different value may be required according to tubes you power. Consult text on this page.

R3—Value depends on filament drain of tube(s) you power. Consult text to figure value.

T1—120 VAC primary, 120 VAC, 15 mA and 6.3 VAC, 0.6 A secondaries, power transformer (Stancor PS8415 or Allied Radio number 705-0034)

D1, 2—25 VDC zener diodes (1N756 from James Electronics, or equiv.)

D3—3.3 VDC zener diode (1N746 from James Electronics, or equiv.)

S1—SPST, 120 VAC switch

Misc.—AC line cord, old B battery or other case, wire, solder, brackets, etc.

Allied Electronics' address is 401 East 8th St., Ft. Worth, TX 76102

James Electronics' address is 1021 Howard St., San Carlos, CA 94070

either the load draws the current or the Zener does. The Zener must always have a current flow through it so we allow 10% of the load current for the Zener. To determine the resistance of R use Ohm's law, and divide the difference between the load voltage and the voltage at X by 110% of the load current. If you use two filter capacitors, as I did, divide R in half and you have R1 and R2.

$$R = \frac{E}{I}, \text{ or,}$$

R1 + R2 equals E (volts) divided by I (amperes). To determine the power rating of R1, 2, 3, use power equation. $P = I^2R$, Power (watts) equals current (amperes) squared, times the resistance (ohms). To determine the power rating of the Zener divide the voltage rating by 110% of the load current. Then add

(Continued on page 100)

Author tries to tune in a station, apparently unaware that the batteries aren't hooked up to his receiver!



CB BATTERY CHARGER SAVES \$\$\$

Low-cost project charges inexpensive nickel-cadmium cells to keep you on the air for pennies an hour.

by Herb Friedman W2ZLF



□ If you're a typical user of one of those high-power hand-held CB walkie talkies rated between 3- and 5-watts input, you know that batteries don't come cheap. And if the cost of the batteries doesn't get you, their leakage will. Leave the power switch on overnight by accident and it's a good bet by next morning the hand-held set will be dripping battery *gook*.

But there is a way to beat the problems of high battery upkeep and leakage, and also to insure maximum RF output at the same time. The answer? Switch to nickel-cadmium (NiCad) penlight batteries (AA size). Are they expensive? Not any more. A NiCad should cost about the price of two alkaline batteries, or even less, and the NiCad can be recharged hundreds, possibly a thousand times. If you use a hand-held transceiver you'll break even

on the second or third recharge.

Hold on, don't go running to the parts catalog to look up the price of NiCads, you probably can't afford them at catalog prices. What you need is a surplus dealer. You see, today everyone is in a hurry and most people can't wait the usual overnight period to recharge NiCads—they demand a *fast-charge* battery. So hundreds of thousands of the overnight (or *trickle* charge) NiCads were dumped on the surplus market, and you can buy them for as little as a buck a piece, no higher than \$1.50. And you get a tremendous advantage with the trickle-charge NiCads: they hold their charge much longer than the fast-charge type. Charge 'em up, stash the transceiver in the closet, or the trunk of your car, and a week or two later they will deliver almost full power. Fast charge NiCads

can't hold a charge that long.

You Can Refrigerate 'Em. Speaking of car trunks, if you leave a hand-held CB set in the trunk and the temperature plunges down near freezing ordinary penlight batteries aren't going to deliver much operating time. But NiCads will still be going like gangbusters in cold weather long after standard batteries are too pooped to pop.

Can your hand-held use NiCads? Simply look inside to tell. If your hand-held uses penlight (AA) size batteries there is probably room for twelve cells though only ten are used; a filler takes up the space of two cells. Since the standard battery delivers voltage of 1.5,

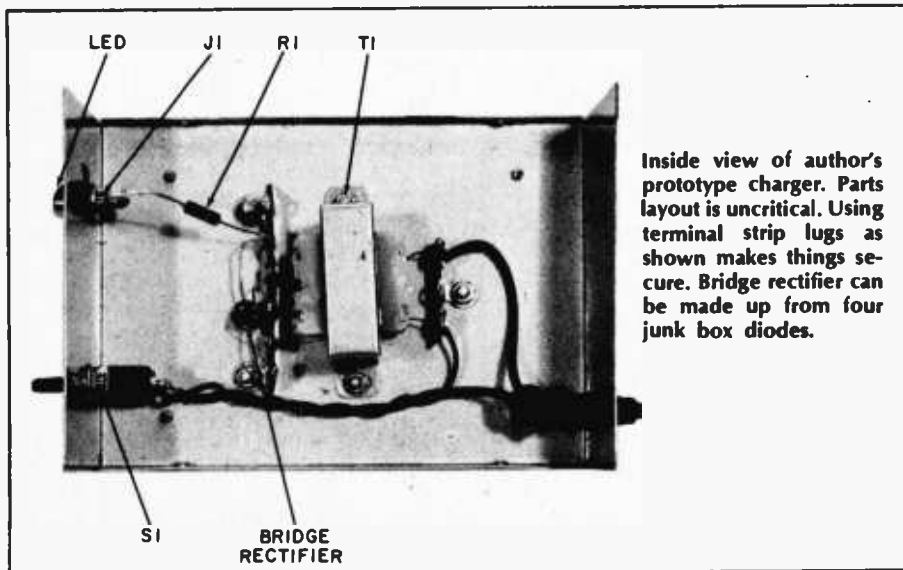

Inside view of author's prototype charger. Parts layout is uncritical. Using terminal strip lugs as shown makes things secure. Bridge rectifier can be made up from four junk box diodes.

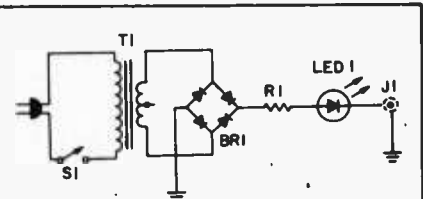

Bridge rectifier with low-cost diodes.

PARTS LIST FOR CB-BATTERY CHARGER

- R1—220-ohm, ½-watt resistor
- T1—24-28-VAC power transformer rated 100 mA.
- BR1—Bridge rectifier, 50 PIV, 100 mA.
- LED1—50 mA.
- J1—Phono jack (Radio Shack 274-1575 or equiv. Includes PL1, below.)
- PL1—Phono plug (see J1, above)
- PL2—Plug to match transceiver power input receptacle
- S1—Switch, SPST
- Misc.—Cabinet, terminal strips, wire, solder, etc.

ten batteries equals a fresh power pack of 15 VDC. But NiCads only deliver 1.2 volts, so twelve batteries are required to produce 15 VDC. The two "extra" NiCads fit in place of the filler. So in order to use NiCads your set must provide room for twelve, rather than ten cells. There must also be a jack on the side of the transceiver to which a charger can be connected. If you have both these conditions (space for twelve cells, and a charger jack) you can use NiCads. The only exception to this rule is a few models which cannot accept NiCads because some NiCads are very slightly longer than a standard penlight AA battery, or the CB set manufacturer did not allow for the extra size even though he provided a charger connection. Make certain your hand-held set will accept NiCads before you buy them.

Really Low-Cost. Finally, you need a NiCad charger, and that's where you can spend real money, but really! One of the top instrument companies charges \$30 for a NiCad charger you can build for less than \$8. They get this exorbitant price because they manufacture one of the very few chargers that can handle all twelve batteries at the same time. Most chargers handle only four to eight cells at a time, taking two to three days to recharge a complete set of NiCads. If you can recharge all twelve cells at once you plug it in in the evening, and you're ready to go the following morning.

The diagram shows a simple but effective charger circuit that will handle up to twelve cells simultaneously. It needs no regulation or control because it trickle-charges any type of NiCad. You can even leave it plugged in continuously without fear of damage to the cells, thereby insuring the NiCads are always in a state of full charge. The charging current is 40 to 50mA regardless of the number of cells (in case some become defective), or their state

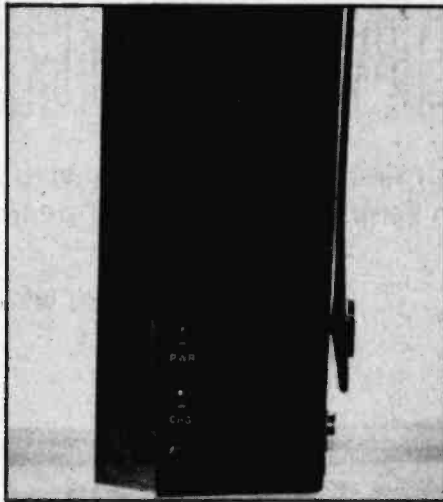

Side view of author's CB transceiver shows two inputs, one for charging internally-contained Nicad batteries.

of discharge. From full-discharged to fully-charged the charging current is always a safe 40 to 50mA.

Use These Parts. Excepting the cabinet, if you select surplus components the whole thing will cost less than \$8. If you buy all new, you'll run up unnecessary expense, which have no effect bearing on the performance.

Transformer T1 is 24-to-28 VDC at no less than 100 mA. It doesn't have to be more than 100 mA. Don't waste your money on a high current filament transformer. If you use a 28-volt transformer increase R1's value to 270 ohms. BR1 is a 50 PIV bridge rectifier rated 100 mA or better. Use the least expensive type you can get. If you have four discrete silicon diodes lying about simply connect them as the bridge circuit.

LED 1 serves as both a pilot light and Charge indicator. If the LED doesn't light the batteries aren't being charged. The LED also serves as a fuse. If the rectifier and R1 short out the NiCads will attempt to discharge through the diodes and the

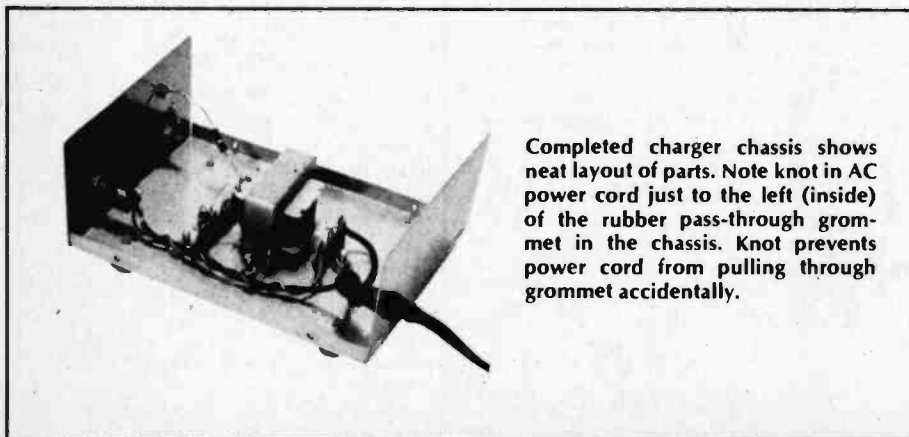

Completed charger chassis shows neat layout of parts. Note knot in AC power cord just to the left (inside) of the rubber pass-through grommet in the chassis. Knot prevents power cord from pulling through grommet accidentally.

high discharge current could cause considerable damage. But the LED will burn up almost instantly, thereby opening the circuit to the batteries.

The LED is the only critical component, in the sense you must be certain it is rated for a *maximum* of at least 50 mA. We suggest a diffused LED be used as its light can be seen from the sides. If possible, use a Radio Shack 276-026 for LED 1.

To mount the LED simply push it through a hole in the front panel of whatever you use for the cabinet. If you connect R1 between the LED and a terminal strip as shown in the photographs the LED will be held in position without need for glue or a lamp mounting kit. The cabinet can be plastic or metal; the one shown in the photographs is Radio Shack 270-252.

How To Connect It. The charger's output is through phono jack J1 rather than a direct cable. In this way different patch cords can be connected to accommodate the several styles of plugs required for transceivers charging jacks. Just make certain you get the charger plug polarity correct. Before PL2 is wired, insert it in the transceiver's charging jack and measure the voltage across the jack noting the plug's polarity. Normally the shield is ground (-) and the tip (center conductor) is positive, but it can sometimes be the other way round. Make certain the charger's positive output connects to PL2's positive terminal. You can damage the NiCads badly if you get it reversed.

Note that most transceivers are disconnected when the charger plug is inserted, so don't expect to operate the transceiver while charging the batteries.

Using The Charger. Resistor R1 limits the charger's output to 40-50 mA even if the output jack is shorted, so the charger can be used with hand-held transceivers that use ten, rather than the usual twelve NiCad batteries. Regardless of the number of batteries the charging current remains a safe 40 to 50 mA. Normally 14 to 16 hours will be required for a full charge, so this can be done overnight. If you want the batteries maintained fully charged and ready for use at any time you can keep them on continuous-trickle charge.

The only caution is not to try and charge two or more hand-helds at the same time. Don't make up a "Y" adaptor that connects two or more hand-held battery packs in parallel because one pack will discharge into the other, and if there is a weak cell in one pack the other pack will discharge with excessive output current. Charge only one set at a time. ■

Hobby Electronics

Newsletter

ELECTRONICS FOR EVERYONE. At one time the term "electronic hobbyist" referred to individuals with specific interests in subjects primarily related to the field of electronics. The amateur radio operator, the general-electronic experimenter, the high fidelity enthusiast who builds his own receiver and amplifier, these are the ones most persons think of when the term "electronics" is used. Perhaps these were the ones who had a working knowledge of electronics in days gone by, but this is 1977, the age of the multi-function integrated circuit, the computer-on-a-chip, the shirt-pocket calculator, the combination cash register/credit card system/inventory terminal of the department and discount stores: Electronics reaches out and touches, influences or controls most of everyone's activities from morning to night, and nowhere is the influence of that magic thing termed "electronics" more evident than in hobbies— almost any kind of hobby.

STAMPS AREN'T ELECTRONIC. In almost any discussion concerning the electronic explosion someone is certain to claim you don't need electronics for everything; certainly not for collecting stamps and coins. In actual fact even the stamp and coin hobbies use some type of electronic system to increase the enjoyment derived by philatelists (stamp collectors) and numismatists (coin collectors). Electronic color comparators can sense a difference in the color shadings of stamps impossible for the human eye to detect, while microscopic implusions caused by ultrasonic sound waves are used to clean coins without damage to, or microscopic removal of, the coin metal -- only the dirt goes.

THE UNIVERSAL HOBBY. In a sense "electronics" has become the universal hobby, actually the central theme or aspect of many hobbies, in contrast to a peripheral effect as in stamp and coin collecting. An overview of some of the hobbies and interests that utilize electronics might give you fresh ideas for old interests and new directions for hobbies which simply didn't exist a few short years ago.

COMMUNICATIONS. The term "communications" means many things to many people. It can mean newspapers, verbal information exchange between an advertising executive and his account or client, a "phone phreak" making a telephone call to his next door neighbor by routing his voice around the world via cable and satellite, even a catcher wiggling two fingers to his pitcher when he wants a change-up (one finger is always the fast ball); but to us in electronics communications means amateur radio, CB (Citizens Band), SWling (shortwave listening) and personal computers -- four of the most exciting hobbies just about anyone can get into.

AMATEUR RADIO. Though the old image of the ham down in the basement surrounded by racks of equipment, pounding away at a telegraph key, has been replaced by the ham sitting in front of a commercial transceiver in his living room holding a microphone, there are still the "brass pounders" who insist on building everything they use just as there are hams who use only store-bought equipment because their primary interest in amateur radio is to simply talk with new and old friends, much in the manner of the average CB operator. In between the basement brass pounder and the "communicator" is virtually every experimental interest possible in electronics -- all made possible by a small square of paper we call an "amateur radio license." Interested in radio-teletype operation (RTTY)? It's possible with a ham license. Got the itch to own your own experimental TV station? Again, the ham licence is your permit to use the airwaves. Want to bounce signals off the moon? Hams have been doing it for years. Or maybe you would like to be able to make telephone calls from your car without giving Ma Bell a week's wages once a month for the privilege; you can usually do it for little more than the cost of a local telephone call if you're a ham using 2-meter FM and your club is running a repeater with an autopatch, a device that permits you to dial directly into the telephone lines from your mobile transceiver, or hand-held (what we now call a walkie-talkie). Repeaters with and without autopatch are also run by ham clubs on the 220 and 450 MHz bands for the UHF experimenters.

UNFAMILIAR WITH REPEATERS? They are receiver/high power transmitters installed on high points by local ham clubs in virtually every moderate size city across the country. They pick up the weak signals from mobile transmitters and even 1-watt hand-helds and rebroadcast the signals for up to 50 miles. Next time you see a civilian with a hand-held hanging from his belt figure it's a ham with communications to the phone, home, and other hams through a local repeater.

WORLD WIDE COMMUNICATIONS. Of course, amateur radio offers the chance to talk with hams in almost every country 'round the world. For thousands and thousands of hams the chance to find out how the rest of the world lives, works and plays is the most important facet of amateur radio. But without that little slip of paper with your name and call letters you can do no on-the-air experiments and no DX communications.

CB IS A HOBBY. It didn't start out that way and many still won't acknowledge the fact, but the majority of Cbers are hobbyists, using the Citizens Band much in the same manner as radio amateurs use the UHF

ham bands such as 2-meters. The major difference between the ham and CBER is that the CBER is a "communicator," usually interested primarily in talking to, and meeting with, other people. Except for antennas there is virtually no experimental or build-your-own aspect to CB because the Federal Communications Commission does not permit anyone but a person holding a first or second class commercial license to work on the transmitter section of a CB transceiver. Nor does the FCC permit modification to type-accepted transceivers. But CBERs have done outstanding work in getting antennas to push the signal out an extra mile, and yet another extra mile, and today CB signals are broadcast and CB contacts worked over distances undreamed of back when CB started.

In the main however, most CBERs are "communicators." To join in the CB fun all you need is a transceiver and an antenna. You screw two connectors together and the rig is ready to go on the air. It's that easy. Power? Oh yes. Either splice into the hot wires under your car's dashboard, tap the fuseblock, or plug into the cigarette lighter. For those who like a little build-it-yourself adventure or electronic experimentation the CB parts stores usually stock racks of antenna parts (so you can almost design and construct a custom antenna system, power microphones, noise and hash filters, general accessory electronic hardware, and of course, the measuring equipment such as SWR and field strength meters to help get everything working at peak efficiency.

SHORTWAVE LISTENING. To the shortwave listener, or **SWL** as he or she is known, listening to foreign broadcasts, ships at sea, airplanes, radiotelephone, police and fire services, and even military units on maneuvers or in action is the next best thing to eavesdropping on the whole world. Using anything from a transistor radio that can receive stations from South America at night, to sophisticated scanners that sweep all local police and fire frequencies until a "call" is sensed, the SWL shares in the daily life and high adventure in other places and in other people's lives. Most SWLs use the so-called "shortwave receiver" which tunes from about the bottom of the American broadcast band to 30 MHz. This range of frequencies takes in American and some foreign standard broadcasting stations, ships at sea, overseas press, radioteleprinters, some of the popular amateur radio bands, military frequencies (particularly of those cockamamie postage-stamp size "emerging nations" that are always at war with someone) and most important the foreign broadcasts beamed especially at the U.S. For example, you can get the latest news from Europe edited for the U.S. via the BBC transmitters, or the rantings, ravings and twisted lies of Radio Moscow in idiomatic American English. Fact is, some of the Radio Moscow announcers are so highly trained it sounds via shortwave as if they were born and raised in the American or Canadian midwest.

POLICE, FIRE, RESCUE, and the other land-mobile radio services can be heard with a VHF-UHF FM receiver that covers the special bands reserved for these services between 30 and 450 MHz. For specific services, such as the local police and fire departments, a receiver that uses crystals for each channel is adequate. For the SWL who wants coverage of all frequencies and services there are digital receivers that can be user programmed for any of the public service frequencies. To help find local stations several directories are available which list "emergency frequencies" by state, city, county and town.

SPECIAL SWL EQUIPMENT is generally home-built, such as antenna tuners to snatch the weakest of signals from the airwaves, directional antenna arrays for the DXer who brings in TV stations from hundreds of miles over the horizon, and frequency calibrators that permit a general coverage receiver to be set precisely to a desired station's frequency, even if the station isn't sending a signal. But if you have no skill at electronic construction these very same items are available commercially made, so those who are interested in listening rather than building can have hassle-free SWLing.

PERSONAL COMPUTERS. Imagine a full computer not much larger than a portable typewriter that you can talk to in plain English. Imagine, also, the same computer talking back to you in English. Sound like science fiction? Not so. Personal computing is the hottest thing going in hobbyist electronics. For less than the cost of a decent -- not the best -- high fidelity system, or the cost of a color TV, computer phreaks are installing microcomputers in their home that do as much, if not more, than many giant computer installations of a few years ago. These personal computers come in many different configurations, from small boards capable of playing a few games to typewriter size jobs that can handle extended BASIC language that works math problems involving the trigonometric functions such as sine, tangent, etc. Computer hobbyists even build small terminals that use their TV set for the readout, or they feed small terminals via the phone lines into a time-share computer service. For those more interested in the software end -- the actual programming and use -- complete hobby terminals and computers are available both kit and wired at hobbyist prices. Since personal computing is an entirely new field there's not much readily available in the way of articles for the beginner--most articles are for the engineering student or graduate--but how-to articles specially intended for the electronic hobbyist and beginner can be found in **ELEMENTARY ELECTRONICS** magazine.

ELECTRONIC CONTROLS TAKING OVER. If you're a photographer you've probably noticed that many modern 35 mm cameras have electronic-controlled light meters and shutters. You can also go a step further and use simple-to-build hobby projects to determine exposure and filtering when making color prints, or make your own black and white enlarging meter for about 25 percent of the cost of a commercial meter. For the model railroader there are hobby electronic speed controllers that provide exact-scale motion for the engines and switching, while the model airplane and boat hobbyist can build digital control kits that provide the exact motions of real planes and ships.

IN SHORT, in today's world, electronics affects so many things that maximum enjoyment from almost every hobby or interest is enhanced by hobby electronics.

WE HOPE YOU HAVE enjoyed this special introductory issue of **HOBBY ELECTRONICS**.

BUILD SELECT-A- SPEED MOTOR CONTROL

Beginner's project that provides choice of speeds for electric drill and other AC devices.

by the Electronic Assembly Class
Central High School, Bridgeport, Connecticut



□ We have all become conditioned to expect rapid transportation via fast cars, streamlined trains and supersonic jets. We've learned to expect instant . . . cash, credit, headache and stomach relief, rebates, replays and foods. No wonder we seldom think of speed in terms of anything less than maximum. 'Twould seem practically un-American.

However, those of us who have to work with non-ferrous metals, with plastics, or hard woods, find it important to get intermediate ranges of speed (rpm) with portable electric drilling equipment. The Select-A-Speed motor controls described here accomplish this goal. The smaller model continuously varies the rpm of portable 1/4-inch electric drill motors, and the larger unit provides incremental speed changes using a switching arrangement,

a feature not previously seen on a control of this kind.

How It Works. The heart of these units, a silicon controlled rectifier (SCR) is a four-layer device whose construction is shown in the diagram. Alternate half-cycles provide the forward bias to cause the conduction, which occurs when the gate is properly triggered. The RC time constant, provided by the resistance and the capacitance controls the rate of charge of C1. Here's how the circuit acts.

C1 will discharge through I1 when the charge on C1 is equal to the ionizing potential of I1, thus providing the gate with a signal. Once triggered, conduction is sustained until the negative half-cycle reverse-biases the SCR at which time conduction ceases until the cycle is repeated. As more resistance is introduced the RC time constant is increased. The resulting increased phase shift further delays the time at which the gate is triggered. This causes the SCR to conduct for less time, and the available load power is thus diminished.

Can Control Many Devices. This versatile unit also functions well as a temperature-control device for pencil-type soldering irons, and also regulates the intensity of conventional desk lamps as well as photo-floods.

In addition it works well to control the speed of electric sewing machines and other small motor-driven hand tools. However, you *must not* try to use it to control devices which have transformers in them, such as soldering guns (pencils are OK), high intensity lights, etc. Of course it won't work at all with fluorescent lights, because lower voltage won't be sufficient to work

the starter.

Any number of switch positions may be incorporated. One prototype of ours had ten. Whether you opt for three,

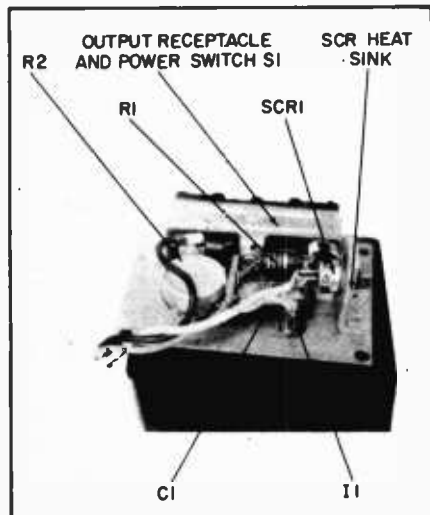

View inside speed control which is continuously variable. Note SCR heat sink.

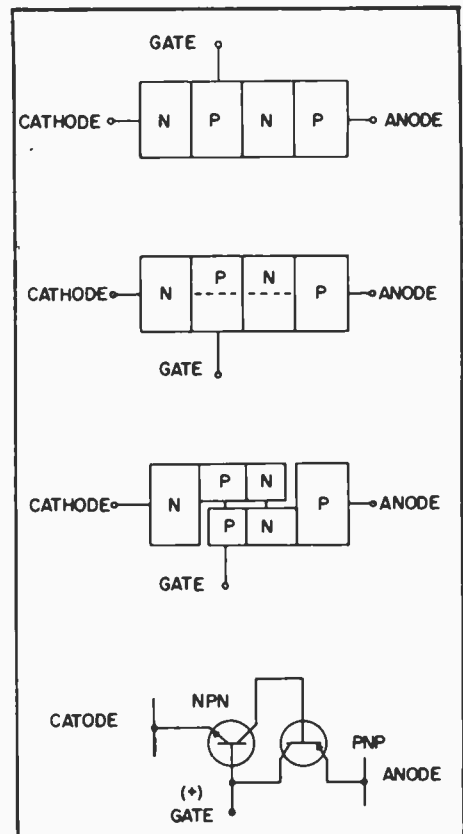

Silicon-controlled rectifier is a four-layered device. Simplification is shown at top. Gate voltage cuts off current between cathode (left) and anode (right). At bottom is a schematic diagram showing the SCR acts as though it were two transistors, an NPN and a PNP, together. Positive voltage on gate (of NPN) causes that "transistor" to conduct.

SELECT-A-SPEED

four . . . or ten, the option merits consideration. Having this choice eliminates sharpening drill bits so frequently as would be required without speed selection. Utilizing too high a speed for a given material is similar to "running in place" . . . neither gets you anywhere; both are dulling! Operating at speeds less than those recommended tends to cause breakage and invite phy-

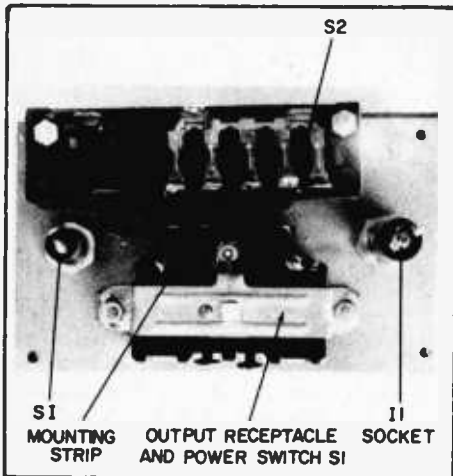

View inside 4-speed control shows push-button switch at top. Similar to fan controls.



Variable-speed unit uses potentiometer for smooth, continuous control.

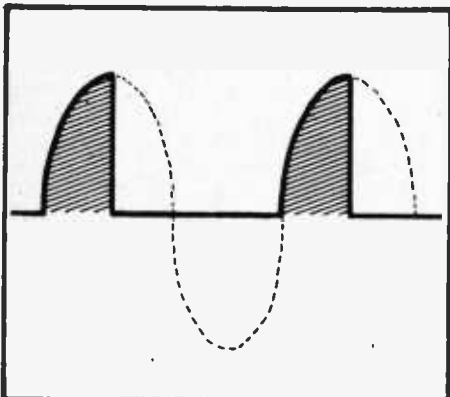

Oscilloscope screen shows portion of AC sine wave during which SCR permits current to flow (cross-hatched parts).

sical harm to one's person.

The resistors may be of any wattage and their ohmic resistance figured on the basis of the speeds most useful to you. We actually found the resistor values for optimum operation by using a resistance substitution box.

Parts placement is not critical. The controlling SCR should definitely be heat-sinked. Be sure that the SCR is electrically insulated from the sink or chassis. It is necessary to use silicone grease to insure proper heat transfer. Don't exceed the wattage rating of the SCR!

All switches used in our prototype models were bought through a source of surplus supplies. Each was modified

to meet our particular needs. Incidentally, we noted no appreciable difference in speed between conditions of load and no load.

A photograph of the waveforms was taken across the load with the SCR as the controlling device. The SCR was apparently conducting during 90 degrees.

The industrial electronics class of the Career Education Department of Bridgeport Central High School worked on this project. Special credit is due Anthony D'Andrea, Torcato Caldas, Brad Hechler, and Chris Shamiss. Class instructor, under whose supervision this project was completed, is Edward M. Allen.

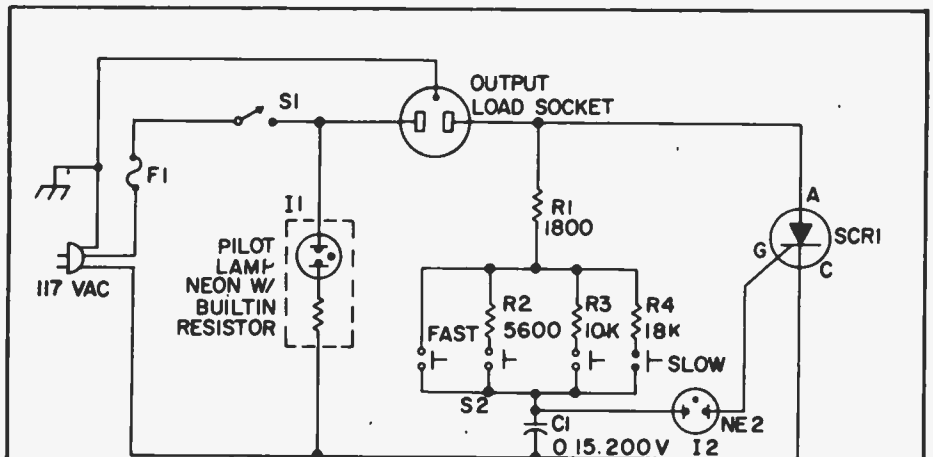

CONTINUOUS CONTROL

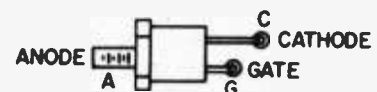
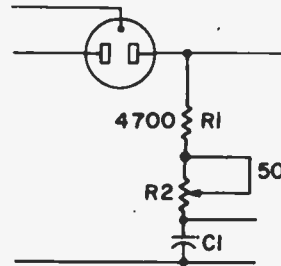

PARTS LIST FOR 4-SPEED CONTROL

- C1—0.1 to 0.2- μ F, 200-V DC (or better) capacitor
- I1—Indicator light, neon, with resistor built into holder, 117 VAC
- J1—Outlet socket and toggle switch, duplex unit, 117 VAC (from electrical or hardware store).
- Q1—Silicon-controlled rectifier, 200 VDC or better, 8A (Motorola HEP-R1243 or equiv.)
- R1—1800 ohm, $\frac{1}{4}$ - or $\frac{1}{2}$ -watt resistor
- R2—5,600-ohm, $\frac{1}{4}$ - or $\frac{1}{2}$ -watt resistor
- R3—10,000-ohm, $\frac{1}{4}$ - or $\frac{1}{2}$ -watt resistor
- R4—18,000 or 20,000-ohm, $\frac{1}{4}$ - or $\frac{1}{2}$ -watt resistor

- S1—part of J1, above
- S2—4-position pushbutton switch, heavy duty electrical (10A or better). From electrical or hardware store (similar to switches used on large fans, blenders, etc.)
- Misc.—Aluminum utility box, 6-in. x 3- or 4-in. x 2-in. or more

PARTS LIST FOR CONTINUOUSLY-VARIABLE CONTROL

Substitute the following parts in the 4-speed control list above:

- R1—4700-ohm, $\frac{1}{4}$ - or $\frac{1}{2}$ -watt resistor
 - R2—50,000-ohm potentiometer, linear taper
- Note: omit R3 and R4.

Darkroom Color Analyzer

by Herb Friedman



It's easy to make quality, bright color prints at home with modern color chemistry and this electronic color analyzer!

ONE OF THE SHUTTERBUG'S most satisfying accomplishments is producing his own color prints. For years the time spent on and the cost of making color prints were discouraging, but with modern color chemistry, such as the Beseler system, you can turn out quality color prints in less time than for

black and white (about 3 minutes), and the prints will be far superior to anything you're likely to get from a color lab.

One thing that takes the drudgery out of color work—besides the chemistry—is a color analyzer, a device that gives you the correct filter pack and

exposure time at the very first crack. Most often, the very first print made with the analyzer will be good. At most, it will take perhaps 0.10 or 0.20 change of filtration for a superb print. This is a lot less expensive and time-consuming than making test print after test print. In fact, it's really the color analyzer that puts the fun into making your own color prints!

Color Analyzers Are Not Cheap.

A decent one costs well over \$100, and a good one runs well over \$200. But if you've got even a half-filled junk box you can make your own color analyzer for just the junk parts and perhaps \$10 to \$15 worth of new components.

A color analyzer is basically a miniature computer. You make a "perfect" print the hard way—by trial and error—and then calibrate the analyzer to your filter pack and exposure time. As long as you use the same box of paper and similar negatives, all you need to do to make a good color print is focus the negative, adjust the filter pack and exposure so the analyzer reads "zero," and hit the enlarger's timer switch. Even if you switch to a completely different type of negative, the analyzer will put you well inside the ballpark, so your second print is a winner. (And even if

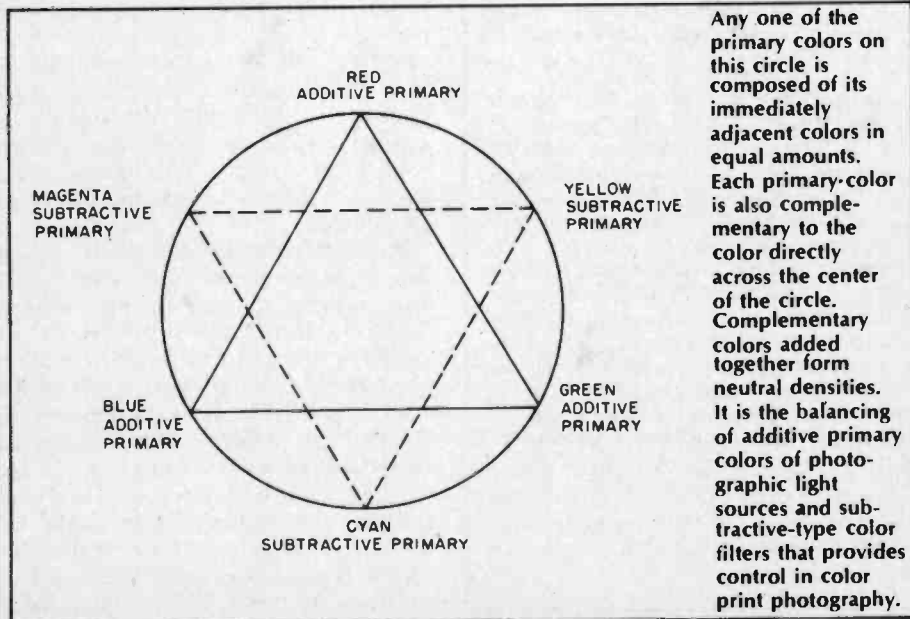

Any one of the primary colors on this circle is composed of its immediately adjacent colors in equal amounts. Each primary-color is also complementary to the color directly across the center of the circle. Complementary colors added together form neutral densities. It is the balancing of additive primary colors of photographic light sources and subtractive-type color filters that provides control in color print photography.

COLOR ANALYZER

the filtration is off, the exposure will probably be right on the nose.)

Construction. The color analyzer shown was specifically designed for the readers of this magazine—essentially an electronics hobbyist with an interest in photography. All components are readily available in local parts stores or as junk box parts. Several protection devices have been designed into the circuit so accidental shorts won't produce

a catastrophe. The printed circuit board template has foils for both incandescent and neon meter lamps, as well as extra terminals so you can use either a socket and plug or hard wiring for the color comparator and exposure sensor. In short, you can make a lot of changes to suit your individual needs.

The template for IC1 uses a half-minidip, Signetics V-type package lead arrangement. However, you can also use an IC with a round (TO-5) configuration. If anything is wrong with the IC you can get the TO-5 out easily. The

half-minidip removal might result in destruction of the PC board. We'll explain how to install the TO-5 IC on the PC board later.

You can either buy or make the printed circuit board (see parts list). Either way, the first step is to prepare the printed circuit board. If you do it yourself, make it any way you like, using free-hand or template resist. Nothing is critical, but be certain there are no copper shorts between the terminals for IC1. Use a #56 bit for all holes. Then use a larger bit for transformer T1's mounting screws (#4 or #6 screws), a 1/4-in. bit for resistor R6, and a #30 to 40 bit for the linecord connections (any bit that will allow the linecord wires to pass through the board).

Assemble the power supply and check it out before any other components are installed. Install transformer T1 first. Any 24-volt or 25.2-volt center-tapped transformer that will fit on the board will be fine. Get something small, like 100 milliamperes. A Wescom 81PK-100 is a perfect fit.

Bridge rectifier BR1 is the low cost "surplus" found in many distributors. This type has the positive and negative outputs at opposite ends of a diamond. The AC connections are the remaining opposite ends. Note that BR1 is installed in such a manner that its negative output is farthest from transformer T1 while the positive output is nearest to T1. Make certain your bridge rectifier has the same lead configuration; if it is different, modify the printed circuit template to conform to the rectifier you're using. Get it right the first time.

Finally, install C1 and C2, R7 and R8, and zener diodes D1 and D2. Take care that the capacitors and zener diodes are installed with the polarity correct. If the capacitors have their negative leads marked with an arrow or line, these markings face the *opposite edges* of the PC board (negative to the outside). The zener diodes are installed so that their cathodes (the banded ends) face each other towards the center of the board.

Initial PC Checkout. When the power supply is completed, temporarily connect a linecord. Connect the negative lead of a meter rated 10 volts DC or higher to the foil between T1's mounting screws (that's ground). Connect the meter's positive lead to the junction of R7 and D1, which is in the center of the board; the meter should indicate approximately +6.2 volts DC. Then connect the positive meter lead to the R8 and D2 junction, which is near the edge of the board. You should get approximately -6.2 volts DC. If the voltages

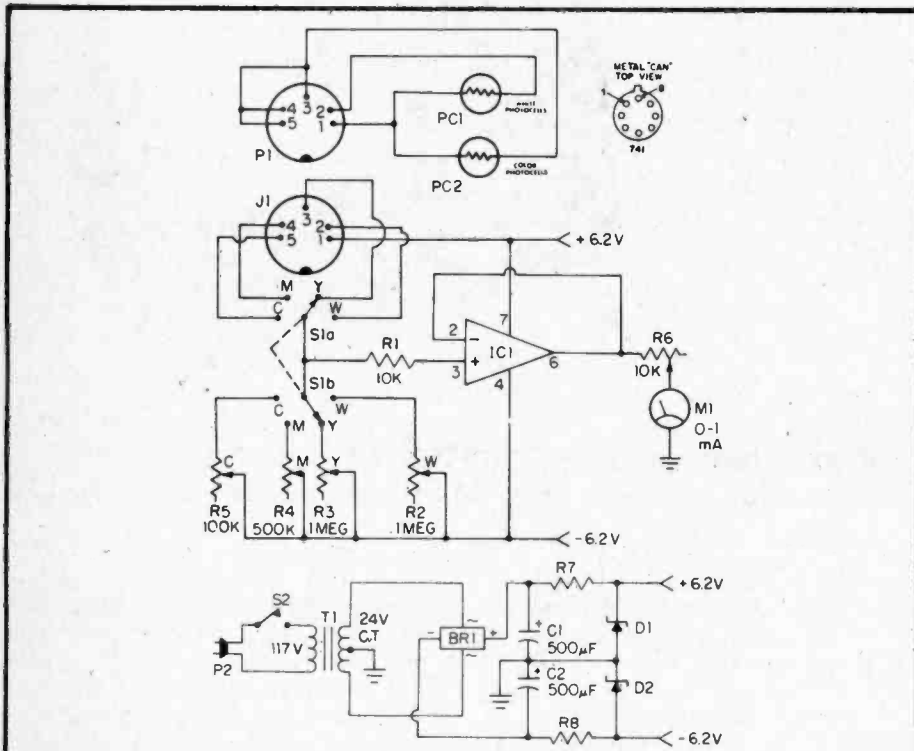

PARTS LIST FOR COLOR ANALYZER

- BR1—50-PIV, 0.5-amp or higher silicon bridge rectifier
- C1, C2—500-µF, 10-VDC or better electrolytic capacitor
- D1, D2—6.2-volt, 1-watt zener diode
- IC1—type 741C operational amplifier, see text
- J1—5-pin socket, DIN-type (optional, see text)
- M1—0 to 1-mA DC meter, see text
- P1—5-pin plug, DIN-type (optional, see text)
- PC1, PC2—Clairex CL5M5L photocell, do not substitute
- R1—10,000-ohm, 1/2-watt resistor
- R2, R3—1-megohm potentiometer, see text
- R4—500,000-ohm potentiometer, see text
- R5—100,000-ohm potentiometer, see text
- R6—10,000-ohm trimmer potentiometer (Mallory MTC-14L4 for exact fit on PC board)
- R7, R8—820-ohm, 1/2-watt resistor
- R9—100,000-ohm, 1/2-watt resistor
- S1—2-pole, 4-position rotary switch (Allied Electronics 747-2003; adjust stops for 4 positions)
- S2—spst switch
- T1—117-volt primary, 24 to 26.6-volt secondary transformer, see text for point-to-point wiring

(Note: you can also use two less expensive 12-volt transformers with secondary windings connected in series-aiding, if you have the space.)

The printed circuit board for the Color Analyzer is available direct from Electronics Hobby Shop, Box 192, Brooklyn, NY 11235 for only \$5.50. US orders add \$1.50 for postage and handling; Canadian orders add \$3.00. No foreign orders, please. Postal money orders will speed delivery; otherwise allow 6-8 weeks for delivery. If you cannot obtain the Clairex Type CL5M5L photocell locally, write to Electronics Hobby Shop at the above address, enclosing \$3.50 for each photocell. U.S. orders add \$1.50 for postage and handling. Canadian order add \$3.00. No foreign orders, please. New York State residents add sales tax. Postal money orders speed delivery; otherwise allow 6-8 weeks for delivery.

Misc.—cabinet, pilot lamp for meter, 2-in. or 3-in. size Kodak Wratten filters #70, #98, and #99 (available from photo supply dealers), calibrated knobs, wire, solder, hardware, etc.

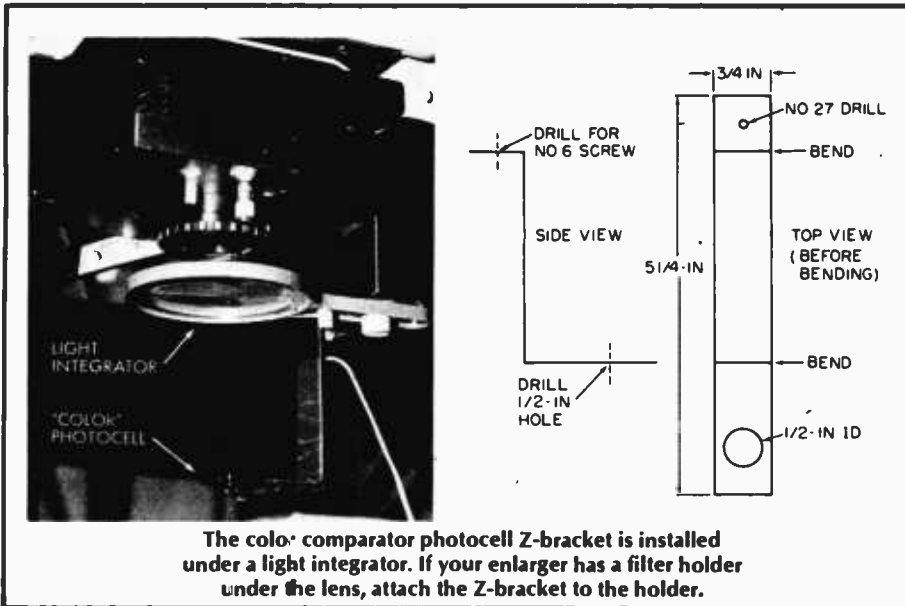

The color comparator photocell Z-bracket is installed under a light integrator. If your enlarger has a filter holder under the lens, attach the Z-bracket to the holder.

are far apart in value, or if the polarity is wrong, make certain you find the mistake *before* installing IC1.

Disconnect the linecord and complete the PC assembly. If you use a 24 or 28-volt pilot lamp to illuminate the meter you connect to the holes adjacent to T1's secondary (24-V) leads. If you plan to use a neon illuminator, install a 100,000-ohm resistor (R9) on the PC board and connect the lamp to the holes marked "neon." The lamp must have as little illumination as possible. Incandescent 24 or 28-volt lamps must be the miniature or "grain of wheat" type rated approximately 30 to 60 mA; the lamps come with attached leads. Do not use pilot lamps of the 100 to 500 mA variety. The excessive light will confuse the analyzer.

To install IC1 when it is the metal can TO5 type, fan out the #1 to 4 leads and #5 to 8 leads so they form two straight lines. Note that the lead opposite the tab on a TO5 package is #8. Insert the leads into the board leaving about 1/4 inch between the IC and the board. The IC is correctly installed if the tab faces *away* from the transformer

towards the nearest edge of the PC board. Solder IC1 and cut off the excess lead length.

The edge of the PC board nearest IC1 has four sets of paired foil terminals. These are provided as mounting terminals if you connect the photocell comparator and sensor without the use of a plug and jack. However, we strongly suggest the use of the specified DIN-type connectors as they allow for easy repairs if the connecting wires break. (The connectors aren't *that* costly).

Potentiometers R2 through R5 can be linear or audio taper, though audio taper gives a slightly smoother adjustment; use whatever you have in stock.

The analyzer shown is built in a Bud 7-inch AC-1613 Universal Sloping Cabinet. This is the least critical item and you can substitute whatever cabinet you prefer. Just be certain the cabinet will accommodate the type of meter you use.

Meter M1 should be 0-1 mA with a zero-center scale. But these are expensive, so you can substitute any standard 1-mA meter you want. You will simply calibrate the instrument for zero-center.

If you use a neon pilot lamp mount it directly above the meter and shield the forward brilliance with a piece of black tape; the lamp should radiate straight down onto the meter scale. If you use the meter in the parts list, remove the front cover by pulling it forward. Then remove the meter scale. As shown in the photographs, place a black dot approximately 3/16-inch wide at the center of the scale. If you want, you can also modify the meter for the incandescent lamp. Drill a 1/4-inch hole in the lower right of the meter *from the rear*. Position the meter in the cabinet and mark the location of the meter hole on the panel. Remove the meter and drill a 3/8-inch hole in the panel. When the meter is installed you can pass a "grain of wheat" lamp through the panel into the meter. Reassemble the meter and complete assembly.

The Comparator. The photocells used for the comparator and exposure sensor, P1 and P2, must be Clairex type CL5M5L. Make no substitutions. From a piece of scrap aluminum 3/4 to 1 inch wide, fashion a Z-bracket to the dimensions shown. Drill a 1/2-inch hole close to the end of the longer Z-leg. Fasten the other end of the Z-leg to your enlarger's under-lens filter holder. If your enlarger does not have a filter

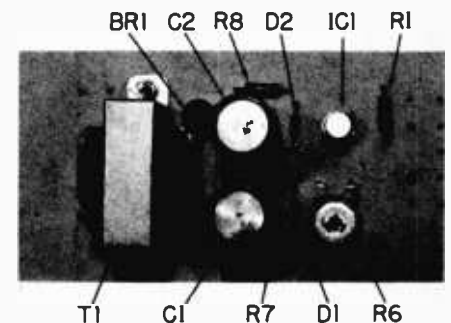

This is the parts location when our PC board is used. To get a free template of the PC board, send a Self-Addressed Stamped Envelope to: Davis Publications, Dept. T, 229 Park Ave. South, New York, NY 10003.

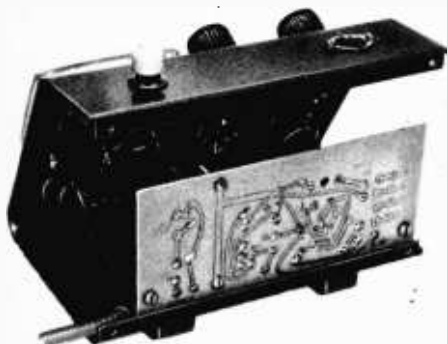

Rear view of author's color analyzer shows vertical mounting of the circuit board.

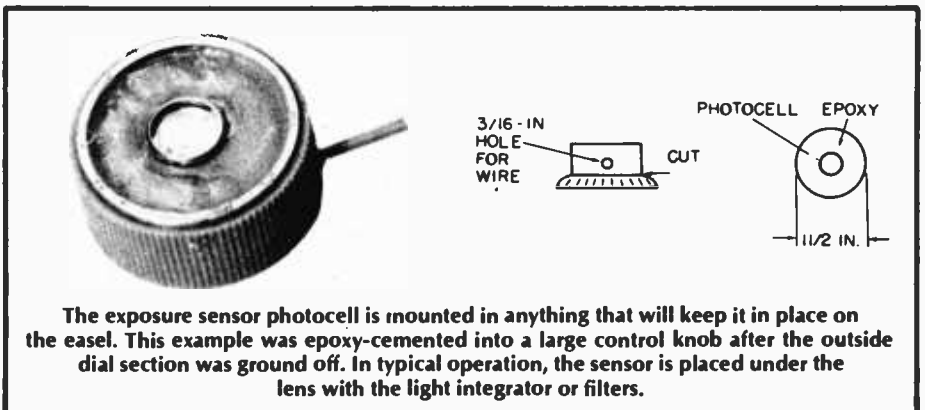

The exposure sensor photocell is mounted in anything that will keep it in place on the easel. This example was epoxy-cemented into a large control knob after the outside dial section was ground off. In typical operation, the sensor is placed under the lens with the light integrator or filters.

COLOR ANALYZER

holder, or if it has a permanent swing-away red filter under the lens, mount a Paterson swing-away light integrator (available from local photo shops) under the lens. Fasten the short leg of the Z-bracket to the integrator—which has pre-drilled holes—so that the 1/2-inch hole is on the optical center of the lens. Then cement photocell P2

the switch and the control "C" for cyan. (We suggest you paint the cyan knob insert a blue-green. Also paint the other knobs the appropriate color.) Advance S1 one position clockwise, find the correct knob and label both "M" for magenta. Advance the switch another position clockwise, find the knob and label both "Y" for yellow. The last switch position and knob is labeled "W" for white (white light exposure). Make certain the C, M, and Y controls are read-



Close-up of meter face showing a small scale-illumination lamp in lower right corner. This lamp should not be operated at full voltage to avoid fogging the film.

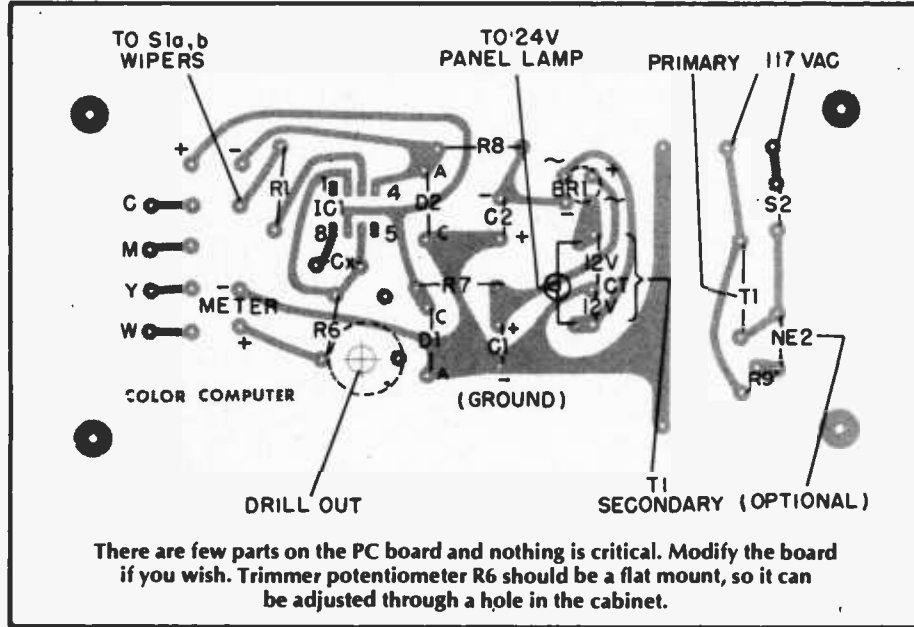

dark or very low light). This is normal and there will be no damage to the circuit or the meter. (Note: If you use a zero-center meter the pointer will barely pin on both sides.)

Install the Z-bracket under the lens. If your enlarger uses a filter holder under the lens insert a diffusion screen or glass, or a Beseler Light Integrator or similar ground glass in the filter holder. You are now ready to make color prints.

The first thing you need to make fine quality color prints is a high speed chemistry, such as the two-step Beseler system which can produce a finished print in two minutes. The second item you need is the electronic color analyzer for which we've already given you the plans.

Color Variables. Color materials such as the negative, printing paper, enlarger lamp, and even color correction filters vary in their sensitivity to light colors from batch to batch, roll to roll, and time to time. Even the enlarger's optical system can have a color cast. For this reason it is generally impossible to place a negative in your enlarger, expose the paper, and develop a good-let alone decent—color print.

in the hole and attach the connecting wires; these can be extra-thin zip cord such as used for short-length speaker connections. (This whole bit reads a lot more complicated than it is. Use the photographs as a guide.)

Photocell P1, which measures the exposure light, can be mounted in anything heavy enough to hold it in place on the easel. The photographs show the photocell epoxy-cemented in an oversize control knob.

When the complete analyzer is assembled, attach oversize calibrated knobs such as the Calectro E2-715 to R2 through R5. The knob calibrations are important so they should run out to the very edge of the knob skirt. If the calibrations don't run to the edge you won't be able to preset the controls with any reasonable degree of accuracy. Place a fine line or other indicator directly above each knob.

Checkout. Connect the photocells to the control unit and apply power. Don't worry if the meter pins at either end of the scale. Set switch S1 to the extreme clockwise position and adjust R2 through R5 until you find the control that changes the meter reading. Mark

ing P2, the color comparator mounted under the enlarger lens.

Set S1 to any position, set all other controls to their mid-position, and turn on bright room lights. If the meter pins out or approaches full scale deflection, adjust trimmer control R6 so the meter pointer just pins (don't be afraid to pin the meter). Depending on the amount of light the meter pointer will pin right (for bright light) and left (for



To avoid upsetting a control setting while groping for the on-off switch in the dark-room, mount switch S2 as far as possible from the controls.



Provides a wealth of worthwhile info for photographers interested in the color print techniques available from Kodak or your photo dealer. Their publication No. E-66.

One way we can correct for these variables is through an *additive* exposure, exposing the paper through blue, green, and red filters for differing lengths of time. Since blue, green, and red create all the colors in additive printing, any correction can be obtained by controlling the precise timing of each exposure. The additive system is a pain in the neck for the hobbyist, for the slightest desired change in the color rendition or saturation (exposure) can involve changes in the exposure through all three filters.

A printing system that's easier to use and more favored by hobbyists is the *subtractive* exposure. A single filter pack made up of two of the filters known as YELLOW, MAGENTA, and CYAN makes all the color corrections at the same time. This filter pack is placed between the enlarger lamp and the negative; virtually all modern enlargers have a drawer in the lamphouse to accommodate a filter pack. A single exposure through the filter pack is all that's required to make a color print. Some of the more expensive enlargers have what is termed a "dichroic head" with variable filters as part of the light system; the exact value of filtration is simply dialed by the user. Again, all the color correction is provided at one time by the dichroic head so only a single exposure is needed.

More Info. A full and complete treatment of both types of color printing is contained in the Kodak publication *Printing Color Negatives*; this book is a required reference for anyone who wants to make quality color prints. The book also gives the most convenient operating procedures for electronic color analyzers.

The subtractive printing procedure is particularly well adapted for use with a color analyzer, is the easiest method for the amateur, and is exceptionally fast-handling, so the illustrations to follow will refer to the subtractive system.

An electronic color analyzer basically consists of a photocell (vacuum tube photomultiplier or photoresistor) positioned under the lens, blue, green, and red filters mechanically positioned over the photocell (or positioned over the cell by hand) and a meter that indicates the amount of light falling on the cell. The meter is connected to the photocell through independent potentiometers as shown in the figure. Color analyzer readings will be accurate for most negatives and lighting situations as long as the same box of printing paper is used. The system needs to be recalibrated only when the printing paper is changed (so purchase boxes of at least 100 sheets to avoid extra work).

The first step is to make a really fine print from a decent negative. You can do it the hard way, one print at a time, or use a Beseler Subtractive Calculator which puts you inside the ball park on the first try. When you have made a print with satisfactory flesh tones and color saturation don't disturb the enlarger or timer controls.

To Continue. . . . Place the color analyzer's probe on the easel or swing it under the lens (if it is mounted on the enlarger). Install a light integrator—which is nothing more than a piece of ground glass or its equal—under the lens, between the lens and the analyzer's probe. The light integrator scrambles the picture into a diffused "white light" which contains all the color elements of your negatives and the filter pack. Place a blue filter (Kodak Wratten No. 98) on top of the light integrator. (Note that most hobbyist analyzers have a selector switch that also mechanically positions the correct filter over the photocell.) Turn on the enlarger and adjust the analyzer's *yellow* control for a convenient reference meter reading. (Usually, center-scale or "null" is used as the reference reading, but any meter reading can be used as a null.)

Remove the blue filter, install a green

filter (Kodak Wratten No. 99), switch the analyzer to *MAGENTA* and adjust the *magenta* control for a null meter reading. Remove the green filter, install a red filter (Kodak Wratten No. 70), switch the analyzer to *CYAN* and adjust the *cyan* control for a null meter reading (the color controls yellow, magenta, and cyan refer to the color of the subtractive filters in the filter pack). Finally, remove all filters from under the lens, switch the analyzer to *WHITE* and adjust the *white* control (exposure control) for a null meter reading.

(The color analyzer in this project uses a separate photocell for the exposure. If you look at the easel you'll

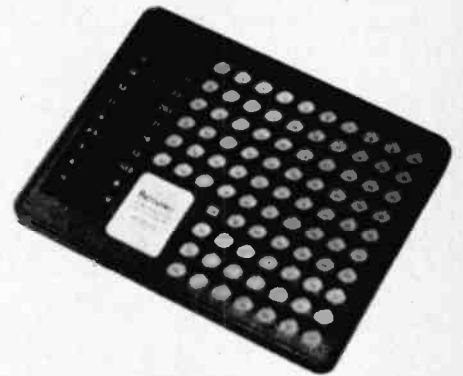

Modern color print chemistry techniques from Beseler include this subtractive color calculator to aid filter selection.

see a shadow cast by the Z-bracket holding the color comparator cell. Position the exposure cell on the easel so it is just off the edge of the shadow. If you prefer, you can place several thicknesses of opaque paper over the color comparator cell and use it for the white measurement, though we suggest you use the separate cell.)

When all the controls are adjusted you have programmed the color characteristics and exposure of your "reference" print into the analyzer, and you should note the control settings and exposure time for future use.

Down to Business. Now assume you want to make a print from another negative. Put the new negative in the enlarger. Then set the degree of enlargement and focus, leaving the lens wide open. Place the analyzer's probe under the lens, install the light integrator and set the analyzer's switch to *CYAN*. Install the red filter on top of the light integrator and adjust the lens aperture until the meter indicates null. Switch the analyzer to *MAGENTA*, install the green-reading filter and note the meter reading. If it is not at null, add or remove magenta filters (from the filter pack) until the meter shows a null. Then switch the analyzer to *YELLOW*, install the blue-reading filter and

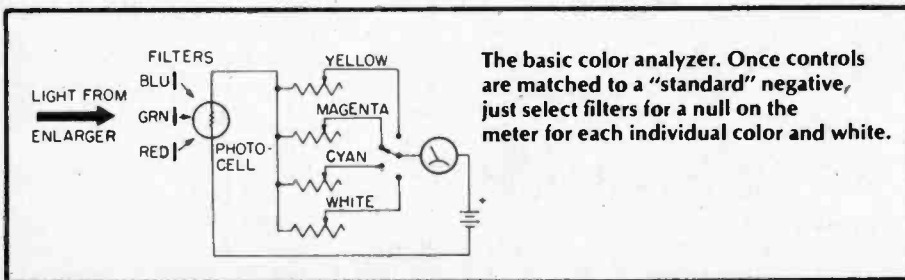

The basic color analyzer. Once controls are matched to a "standard" negative, just select filters for a null on the meter for each individual color and white.

COLOR ANALYZER

modify the yellow filtration in the filter pack until the meter shows a null. Finally, set the analyzer to WHITE, remove all reading filters and adjust the lens aperture for a null indication.

Through the color analyzer you have now established a new filter pack and exposure for the new negative. If the new negative uses similar lighting to the reference negative the print should be perfect. If the lighting was considerably different the print will be good—acceptable to most people, but requiring just a slight filter pack modification for a great print.

Swinging Filters. In the previous example the filter pack would wind up with magenta and yellow filters—which is what is generally needed. Some Kodacolor negatives, however, might require cyan filters plus magenta or yellow (but never all three). This information will have been programmed into the color analyzer, so you will have no difficulty if you make a slight modification in procedure. The first meter reading, the one where you adjust the lens's aperture, should be made for the filter you are *not* using in the filter pack. For example, if your basic filter pack has cyan and magenta, switch the analyzer to YELLOW, place the blue-reading filter in position on the light integrator, and close down the lens for a null indication. Then proceed with the other readings. If your reference negative did not require cyan in the filter pack, if it had yellow, magenta, or both, and you find a new negative just can't be pulled in for null meter readings with yellow and magenta filters, it indicates the new negative requires cyan filtration, so start with the assumption that yellow is not

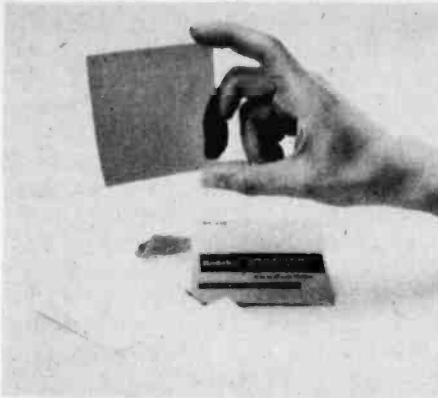

Kodak color printing filters. Typical filter designation CP20Y means color filter with a .20 density; the color is yellow.

required. If you still can't null the meter, it means magenta should *not* be in the filter pack.

As we mentioned, a more thorough discussion and procedure for using a color analyzer is found in Kodak's *Printing Color Negatives*.

Most, but not all, commercial color analyzers use photomultiplier tubes which have no light memory, nor are they confused by infrared from the enlarger lamp. These units are, as you would expect, relatively expensive. Low cost models use photoresistors.

More Data. Photoresistors are infrared-sensitive and they have a light memory, both of which can confuse the meter. The infrared is easily handled by installing a heat or infrared filter glass in your enlarger (it should be there to protect the negative anyway). The light memory is handled by using a consistent measurement procedure. The best way is to turn the enlarger off, install the reading filter and the light integrator, turn off the bright room lights, count to five, and then turn the enlarger *on*.

Take the meter reading, or adjust the appropriate color control, slide the new reading filter in place before withdrawing the old one, switch the analyzer, and make the new meter reading. Repeat this for the third reading filter. You'll note that this procedure keeps bright white light from falling on the photocell between meter readings. If you want to change filters under room lights, make certain there are about five seconds of darkness between turning the room lights out and turning the enlarger on.

The whole bit might sound somewhat complicated, but after you've run through the procedure once or twice to get the hang of things it shouldn't take you more than a minute or so for a full color analysis of a new negative.

The Kodak Wratten filters needed are available from professional camera shops. For the construction project, color analyzer 2-in. or 3-in. Kodak Wratten filters Nos. 98 (blue), 99 (green), and 70 (red) are recommended. If you have difficulty obtaining these specific filters you can make the following substitutions, through the analyzer's precision will be slightly reduced: 47B (blue), 61 (green), and 92 (red).

The Pro Shop. We could not close without some words on commercially processed color prints such as you might order from a drugstore or camera shop. Commercial color labs have as high (if not higher) a remake rate than the amateur if *quality* color prints are desired. As a general rule, it takes two tries to get a decent color print, so the hobbyist with a color analyzer is way ahead of the game because he can turn out, at worst, two *good* prints for each three first tries. The average is even higher than this as the hobbyist gets skilled in the use of a color analyzer.

Commercial labs come close to a hobbyist's results only when they are equipped with a video analyzer such as the Kodak Video Color Negative Analyzer Model 1-K; and Kodak only claims a 75%+ first try acceptance rate for their analyzer. The video analyzer is a 5-in. x 5-in. TV display. The operator views the color negative as a positive color TV image, and adjusts the TV's controls for proper color balance and brightness (saturation). The control settings are translated to the printing equipment's filter adjustments so that the final print is similar to the image displayed on the TV.

The video analyzer is a fast and easy way to get good color prints on the first try, but since video analyzers cost in the thousands, the color analyzer is the best thing going for the hobbyist. ■

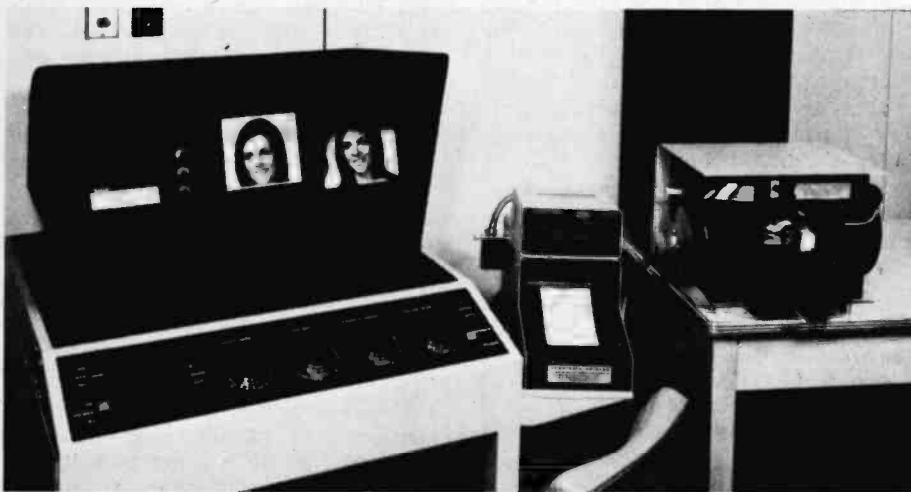

Professional equipment used by color labs includes this Kodak Video Color Negative Analyzer. It uses a 5-in. color TV screen to assist an operator in selecting the correct filter.

555 TESTER

by Martin Weinstein,
WB8LBV, KDT5787

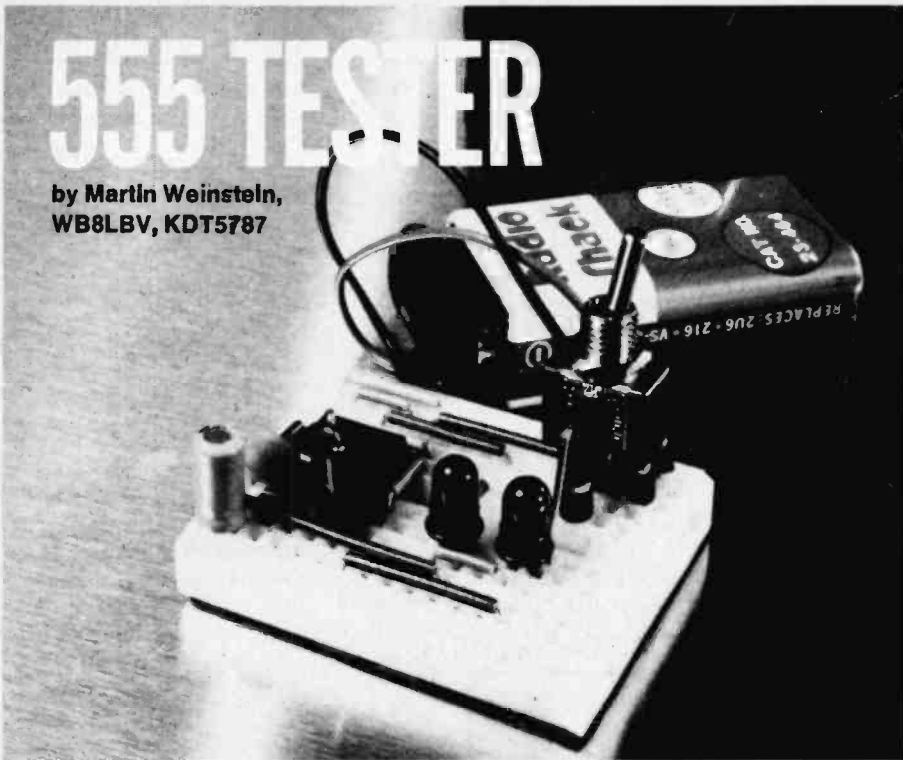

You can test surplus 555 integrated circuit chips in one second with this easy-to-build, simple, project.

ONE OF THE MOST frequently-used integrated circuits today is the 555 timer chip. It's an 8-pin IC, most often found in the Mini-DIP package (rectangular, with the pins in two rows or four each of the long sides). It's also seen in the less-common round transistor-like shape, the TO-5 or TO-99 packages.

It's an IC which can produce a time-delay from a few micro-seconds to about an hour, with five percent ac-

curacy. It can also run free as an oscillator, at frequencies as high as a megahertz (1 MHz) or as low as one pulse per hour! The only external parts are one or two resistors and a capacitor. It can also be used as a comparator, a Schmitt trigger, a controlled switch, and much much more. And today, even though the prices of new integrated circuits are still coming down, you can find untested 555s on the surplus market at great bargains.

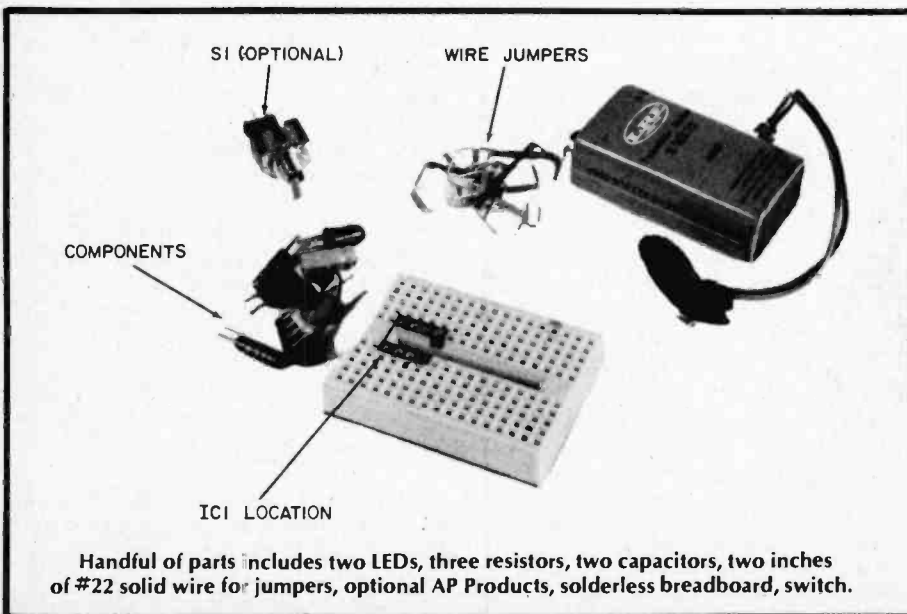

Handful of parts includes two LEDs, three resistors, two capacitors, two inches of #22 solid wire for jumpers, optional AP Products, solderless breadboard, switch.

This project shows a ready way to test these widely-used, widely-available ICs.

Inside, the 555 has many transistors and other components, arranged to make up the following circuits: two comparators, one flip-flop (which is a bistable multivibrator), and an output stage. Connections are brought out to several terminals (up to 8) which hobbyists call "pins."

Inside the 555. First we have a comparator, a kind of balancing beam. It looks at two inputs and compares them. Some comparators supply an output when the voltage at one of its inputs is *larger* than the other. Other comparators, like this one, provide an output when both inputs are *equal*.

Now look at the two inputs this comparator is connected to. One input is a voltage divider inside the 555. This consists of a string of three identical resistors connected between Vcc (B+) and ground (-). Since this leg of the comparator is connected 2/3 of the way up the resistor string, it always measures a voltage equal to two-thirds of the supply voltage.

The other input leg of the comparator is connected to the external timing chip capacitor you use in your particular 555 IC timer circuit. The timing capacitor is charged through a timing resistor (two, actually, series-connected and tapped by a connection to pin 7 in most applications). Together, the timing resistor and timing capacitor determine how fast the 555 will oscillate (or how long an output pulse it will deliver). Here's how.

When the charge on the timing capacitor at pin 6, the *threshold* input, reaches a value equal to the voltage at the on-chip voltage divider (2/3 Vcc), the comparator turns *on*. When the comparator turns *on*, it toggles the flip-flop that switches the 555 output.

The flip-flop also turns on a transistor that discharges the timing capacitor.

How It Works. To start the 555 working, a trigger pulse at pin 2 initially sets the flip-flop to turn the 555 *on*. It does this by comparing the input pulse to 1/3 Vcc at a second comparator. This turns off the transistor across the timing capacitor and allows the timing capacitor to begin to charge. The 555 stays *on* until the timing cycle turns it *off* again by resetting the control flip-flop.

The timing cycle can be made to start over again by applying a pulse to the *reset*, pin 4. This turns on the transistor that discharges the timing capacitor, thereby delaying the charge from reaching 2/3 vcc.

In some applications, the *reset* (pin 4) is connected to the *trigger* input

555 TESTER

(pin 2) so that each new input trigger signal restarts the timing cycle.

When the *threshold* voltage at pin 2 drops, at the end of a timing cycle, that voltage drop can be used to start a new timing cycle immediately by connecting pin 6 to pin 2, the trigger input. This is how the 555 works when it is used as an astable (free-running) oscillator.

The 555 output circuit includes two high current transistors, each capable of handling 200 ma. One transistor is connected between the *output* pin 3 and *VCC*, the other between pin 3 and *ground*. Thus, so you can use pin 3 to either supply *VCC* to your load (*source*) or provide a *ground* for your load (*sink*).

Testing is Fast and Easy. I once

asked an applications engineer friend of mine how he could tell if a particular gadget of his would work. "Make sure it isn't between you and the door, and then plug it in and turn it on!" he said.

This 555 tester borrows on his advice. Instead of trying to measure specific conditions at each pin (the way most tube and transistor testers make their tests), it plugs the 555 under test right into a simple circuit and puts it to work. A good 555 will flash the LEDs alternately. A bad 555 will cause either or both of the LEDs to light and remain lit, but without flashing.

Construction is Fast. The prototype circuit you see here is built on a modern solderless breadboard, this one an A P Products terminal strip. A spring clip behind each hole grips both wires and component leads. Since each conductive metal spring clip is five "holes" long, the breadboard is organized as a

group of five-tie-point terminals.

Jumper wires are used to connect between terminals, and component leads may be inserted directly. Any solid wire from #30 to #20 slips right in and holds securely. I prefer to use #22 solid, and I've bought it in several colors to help me keep track of what's going where. A quarter inch or so of insulation stripped from each end provides a perfect jumper.

The Tester's Circuit. The 555 performs as a simple astable oscillator, alternately flashing the two LEDs. We can drive both LEDs from the single output (pin 3) because of the way the 555 is designed. It is made to either *source* (provide a positive voltage, and thereby current, to its load) or *sink* (provide a minus voltage—ground connection, for the load current) its output. So by connecting one LED from B+ to pin 3 (sinking output) and the other between pin 3 and GND (sourcing output), we can take advantage of both capabilities.

You will notice that I've not included the usual current-limiting resistor in series with each LED. What actually happens is that a single resistor, R1, limits current through the entire circuit. In addition to protecting the LEDs from too much current, it does the same for the 555 under test, and it also prolongs battery life. Finally, it also protects the tester's circuitry in case the 555 under test has a dead short between any combination of pins, as often happens when ICs are removed from surplus printed circuit boards, leaving solder bridges.

The circuit's time constant, which governs the flashing rate, was chosen to make the flash easily discernible. Too quick a flash rate could appear to be a steady *on*. Too slow a flash might look like just one LED lighting. You can alter the flashing rate by changing the value of C2.

R2 and R3 also affect the flash rate, and the ratio of their values determines the *duty cycle* (how long one LED is illuminated versus how long the other is on, in this case). While other values for R2 and R3 could have been chosen, the values shown here were used for several reasons. For one, they're standard and easy to find. Second, they yield a very readable flash rate. And most important, they fit within the ratio-of-resistances required by the internal workings of the 555.

Building It. If this is your first experience with solderless breadboards, it's only fair to warn you that they can be habit-forming.

You'll have the circuit together in less time than it takes to lay out a

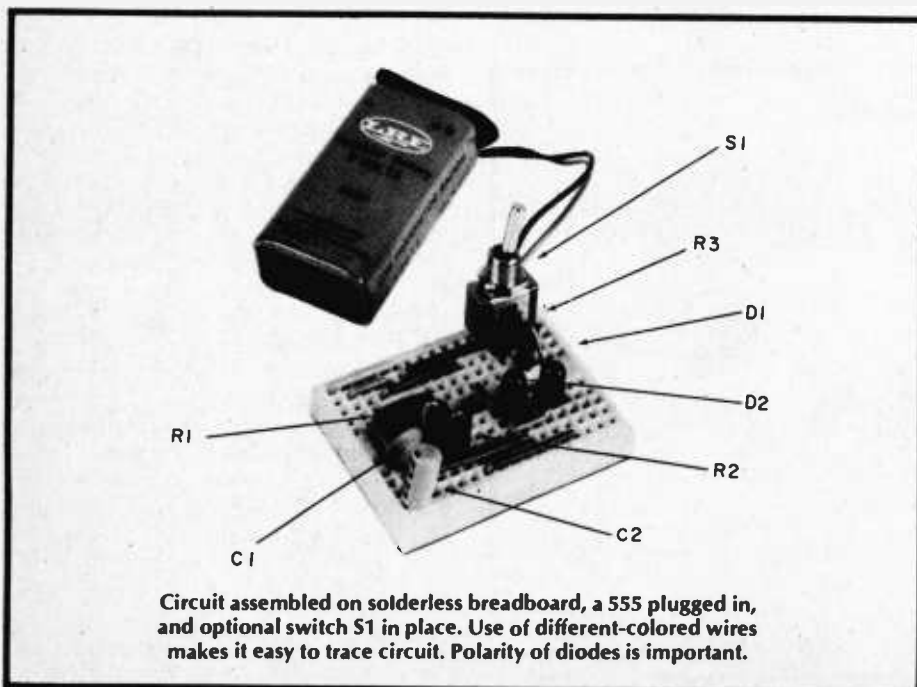
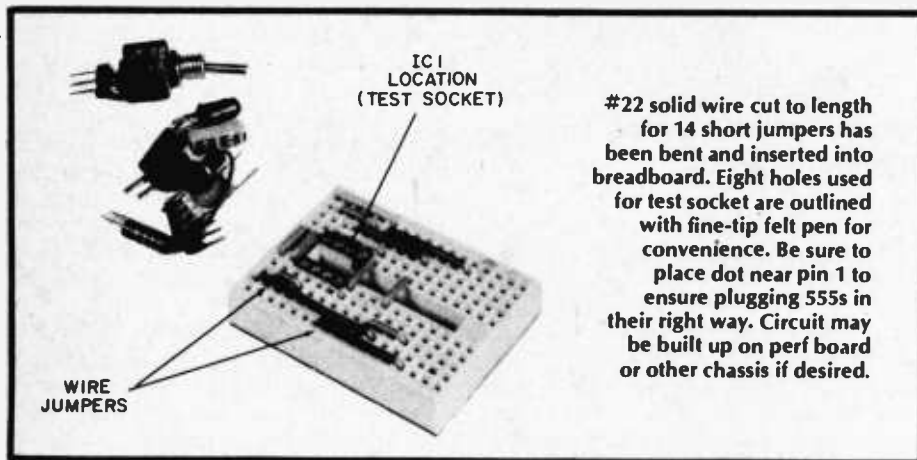

printed circuit board or solder up a haywire circuit. You won't need any hardware at all. You can even leave out the switch if you like, and plug and unplug the leads to the battery.

One of the reasons these solderless breadboards are so fast and easy is that they're designed with a .1-in. x .1-in. hole spacing. Modern DIP (dual in-line package) ICs are designed with leads spaced in multiples of .1-in. So everything we use can plug right into the breadboard. An IC socket here would only be redundant.

This standard .1-in. spacing appears in another handy device that AP Products makes called a *header*. The header is a plastic strip with small contact posts every .1-in. You can break off as many of these as you need, with 36 of them being supplied on each strip. I soldered a piece of header to the back of a small toggle switch so it could plug right in, too. Another small piece soldered to the battery connector makes the entire project plug-in easy.

Follow the diagrams and illustrations as you place each part in position in the breadboard. Mark the breadboard with a felt-tipped pen to show where the 555 under test plugs in, and be sure to index pin 1. Also mark the positive and negative battery connection points.

Jumper Wires. Use #22 solid wire. Cut about 1/2 inch longer than jump (connection) needed. Strip 1/4-inch of each end bare and bend at right angles. You will need one .1-in. jumper, one .2-in., six .3-in., one .4-in., one .5-in., one .6-in., two .7-in. and one 1-in. long.

Be very careful removing 555s from the tester to avoid bending their pins. Use an IC removal tool if you have one. If you don't a small screwdriver used as a lever in the deep depression in the center of the IC will let you ease it out safely.

Smoke Test. It won't burn up, if you've been careful. There aren't very many ways to do this circuit wrong. But just to be on the safe side, double check your wiring before you connect the battery.

Then, with no 555 in the circuit, connect the battery and turn the switch (if you've included it) *on*.

If you've wired everything correctly, both LEDs will light. The most likely cause of a LED not lighting, assuming your wiring is correct, is that it has been plugged into the board backwards.

Now go ahead and plug in a 555. Choose one you know is good. The LEDs should start flashing. Play with the value of C2 to alter the rate.

Using the Tester. Since the solderless breadboard is its own chassis, you're ready to go.

I have yet to find a surplus 555 that isn't in a DIP package, but even those 555s that come in transistor-style TO-5 or TO-99 cases usually follow the same lead arrangement. So identify pin 1, plug your 555 in and turn it on.

If both LEDs come on, your 555 is open. If only one comes on, or if neither comes on, your 555 is either open or shorted. If there are no visible solder bridges between pins and no pins are missing, the open or short must be internal. Perhaps you could use a 555 that tests bad as an ornament; you sure

can't use it for electronics.

A good 555 will always flash both LEDs. It's that simple.

Your handy tester even provides a bonus. With a good 555 in place, you can use the pin 3 output as a clock pulse to drive TTL circuitry. You can use the pulse directly, but a small resistor or capacitor will help keep things safe. Remember to use pin 1 for *ground*.

By the way, it probably took you longer just to read this article than it will take you to build your tester. ■

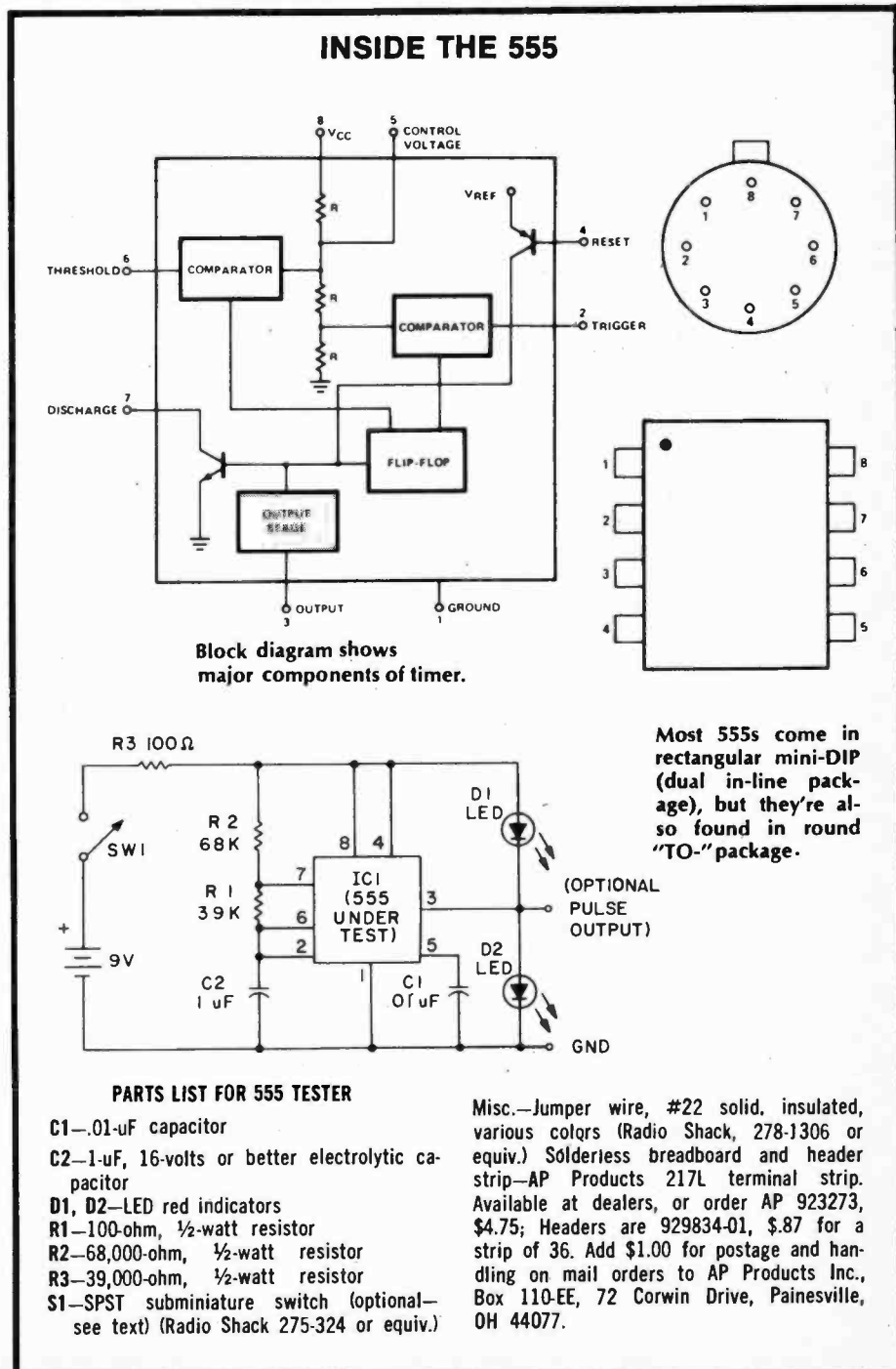

Classified MARKET PLACE

101 ELECTRONIC PROJECTS—PUBLISHED ANNUALLY. The rate per word for Classified Ads is \$1.00 each insertion, minimum ad \$15.00 payable in advance. Capitalized words 40¢ per word additional. To be included in next issue, write to R. S. Wayner, DAVIS PUBLICATIONS, INC., 229 Park Ave. So. NY 10003.

ADDITIONAL INCOME

\$300 WEEKLY, mailing circulars. Samples: 3¢ (Stamps). Gramco, DPBX 99371, Tacoma, WA 98469.

FANTASTIC whirlpool bath! Distributors Wanted. Earn big money! Write: Sterling, P.O. Box 6064, Minneapolis, MN 55406.

ANTIQUES, ARTS & CURIOS

ANTIQUED historical documents and money. Original reproductions on parchment paper. \$2.00 for samples, stories, details. Antiques 1016, Minnelusa, Gillette WY 82716.

AUTO PARTS & ACCESSORIES

PREVENT THEFT with Auto-Guard \$6.95. California residents add tax. Webster Products, Dept. May89 1773 S. Holt, Los Angeles, CA 90035.

BLUEPRINTS, PATTERNS & PLANS

WHAT'S going on in housing? Get advice on how to economize in modernizing or improving or adding space from idea to completion. Working blueprints available. Send \$1.35 for 110 Better Building Ideas to: Davis Publications, Inc., 229 Park Avenue So., N.Y. NY 10003.

BOOKS & PERIODICALS

INCOME Educational, Professional, Sports, Music. List 25¢. Wrights, TH-1-222-S.M., Clintonville, WI 54929.

FREE! List of low cost popular books. Success. Happiness. Wealth. Personality. Personal problems. Sunrise Enterprises 2521, Kolo, Box 298 Kilgus, HI 96754.

FREE LIST LOW COST BOOKS, Elmer and Emma's Gifts, Ottawa, W.VA D25149.

BOOKLOVERS. Wonderful catalog. Show business, financial, general. Ferry Press, Box 2319, Springfield, MA 01101.

IDEA book for re-doing or adding to your kitchen and bath improvements. Send \$1.50 to KITCHEN & BATH IMPROVEMENTS—229 Park Avenue South, New York, NY 10003.

BUSINESS OPPORTUNITIES

FREE Secret Book "2042" Unique, Proven Enterprises." Fabulous "Little Knowns" Work home! HAYLING—E14, Carlsbad, CA 92006.

\$30.00 HUNDRED Stuffing Our Circulars into Stamped Addressed Envelopes. Immediate Earnings. Beginners Kit \$2.00. COLOSSI, 1433-61 Street, DC-4, Brooklyn, NY 11219.

MAKE Magnetic Signs. Big profits. Details, Universal, Lenora, KS 67645.

100% PROFIT Bronzing Baby Shoes. Free Literature. NBC, Box 1904-DG, Sebring, FL 33870.

HOMEWORK! BIG MONEY addressing, mailing envelopes. Exciting offer 10¢. Linco Services, 3636 Peterson, Chicago 60659.

\$25 DAILY POSSIBLE stuffing envelopes! Free details. Services, Box 715D, Lynbrook, NY 11563.

STUFF envelopes \$250+/Thousand. Supplies. Enclose stamped envelope. Route one, Box 263-AB, Paula Valley, OK 73075.

MAILORDER success, 120 ways. Free. New, 7427-C Eccles, Dallas, TX 75227.

HOW WOULD YOU LIKE TO RECEIVE 100 LETTERS A DAY, EACH CONTAINING \$2.00? WILL SEND COPY OF PLANS PLUS 6 FORMULAS FOR \$2.00. RUSH \$2.00 TO MELCOLE INC., P.O. BOX 64733, 5920 UNIVERSITY, DALLAS, TX 75206

BUSINESS OPPORTUNITIES—Cont'd

ELECTRIC TOOL REPAIR. Great opportunity for handicapped, retired, moonlighter. Free information. Catalog \$3.00. Parts, Box 2080, Scottsbluff, NB 69361.

HOME Business, 120 ways. Free. New, 7247-B Eccles, Dallas, TX 75227.

\$600 WEEKLY. Stuff envelopes. 25¢ Aquarius. Box 18439, Milwaukee, WI 53218.

\$50,000 OVERNIGHT! Free details. New, 7247-A Eccles, Dallas, TX 75227.

GUARANTEED \$178.00 WEEKLY. Work one hour daily. Free Brochure. PAS, Box 13703, San Antonio, TX 78213.

MAKE \$1000 per month mailing letters. Free details. Tate, Box 443-DP, Morehead City, NC 28557.

DETECTIVES

POLICE SECURITY INVESTIGATIVE schematics and equipment listings. Quilmtronix, Box 546-DV, Seattle, WA 98111.

DO-IT-YOURSELF

FANTASTIC source book—"201 Free Plans for You"—\$3.00. Stuart, 46 Hillside Rd., Stony Brook, NY 11790.

EDUCATION & INSTRUCTION

UNIVERSITY DEGREES BY MAIL! Bachelors, Masters, Ph.D.s... Free revealing details. Counseling. Box 389 EP-57, Tustin, CA 92680.

BROADCAST STATION: Cable/FM. Start your own! Details free. "Broadcasting," Box 5516-GE5 Walnut Creek, CA 94596.

SUCCESS Programs for Goals Achievement. Details free—Goals Northeast, 20 Clarks Hill Ave., Stamford, CT 06902.

FOR THE HOME

TEAKWOOD PLATES. Now available! Most attractive dinner plates we've ever seen. TEAKWOOD—known for years as the Queen of woods—these plates enhance all table settings, ideal for Home. Boats and campers. Beautiful for Eors D'Oeuves and sponges clean in seconds. TEAKWOOD PLATE \$7.98. Set/4 \$27.98. Fla. Res. add 4% tax. SHOPPERS SHOWCASE 3206 Azele St., Tampa, FL 33609.

HYPNOTISM

FREE Fascinating Hypnosis Information! Startling! DLMH, Box 487, Anaheim, CA 92805.

MAIL-ORDER OPPORTUNITIES

CHURCH picnic recipes. Exciting collection. Cookbook has 130 original, authentic southern styles recipes. \$3.98. LFW Mail Order, 626 Studebaker, Dept. 1D57, Mishawaka, Indiana 46544.

MISCELLANEOUS

MAKE YOUR FORTUNE Selling information by mail. New bookseller's plan tells all. Most anyone can handle. Free details. Andy's Mart-DP. POB 318, Spartanburg, SC 29304.

MONEYMAKING OPPORTUNITIES

FREE "1001 ODDS"! \$10,000-\$100,000 actually made at home by oddsballs! You'll never get over it! Publico-E, Carlsbad, CA 92006.

\$500.00 WEEKLY! IMMEDIATE. Guaranteed home income stuffing envelopes. FREE Supplies! Send 25¢ Stamp. Profits, B725-DP5, Belen, NM 87002.

MONEYMAKING OPPORTUNITIES—Cont'd

\$1,000 MONTHLY POSSIBLE! Mailing Commission letters. Information—FREE! Opportunities, Box 7218M, Lynbrook, NY 11563.

MAKE MONEY NOW! Pros reveals how to write an effective classified ad. Get "How to Write a Classified Ad That Pulls." Includes certificate worth \$2.00 towards a classified ad. Send \$1.50 (includes postage) to R. S. Wayner, Davis Publications, Inc., 229 Park Avenue South, New York, NY 10003.

\$1,000 MONTHLY possible stuffing envelopes. Free details. DB, 928 Ashbury, Evanston, IL 60202.

\$3 HOURLY stuffing envelopes. Easy work. Details free. Feldco, Box 228 Ryder, Brooklyn 11234.

\$25.00 DAILY POSSIBLE stuffing envelopes! Details FREE. SERVICE, Box 715SM, Lynbrook, NY 11563.

\$3 HOURLY stuffing envelopes. Easy work. Free details. Pacific-IO, Box 657, Aberdeen, WA 98520.

BIG \$\$\$ mailing letters. Free details. Shields, 18635 Gloverdale, Covina, CA 91722.

\$1000 MONTHLY possible stuffing envelopes. Details free. Bobmach-IO, 2033 Park Rd. NW, Washington, DC 20010.

BIG MONEY in Real Estate! Past! Secrets of the "Insiders" now revealed. Free information! Report E5, Box 17428, Austin, TX 78760.

FREE MAILERS KIT... Names, Brochures, Postage included to our subscribers! Offer: Rush Stamped, self addressed envelope, Universal F-DV X16180.

\$200 WEEK working evenings at home. Write: Pacific, Box 657, Aberdeen, WA 98520.

GUARANTEED secrets of stuffing envelopes. Free. Trecco, 11450 W. Golf, Miami, FL 33167.

SAVE 20-30% on GIFTS! Also many booklets. Ideas how to make Big Money, with Government Surplus—Stamps, Import-Export, Real Estate etc. Free Catalogs. KOVAK'S VARIETY GIFTS, 1658 West 37th Street, Chicago, IL 60609.

MAKE money writing interesting articles. Don't envy Newspaper Columnists. Be one! Wheaton, Box 52-1, Naples, NY 14512.

\$500.00 and more per 1,000 stuffing envelopes. Complete details 25¢ and self addressed stamped envelope. Haco Enterprises, Box 104 Folsom, CA 95630.

HOMEWORKERS Needed!! \$500/Thousand stuffing envelopes. Free supplies! Send stamp addressed envelope. Brown Enterprises, 156 1/2 Central, Holland, MI 49423.

EARN \$100,000 in 365 days. Details \$2.00. NO WORK, just have fun. MONEY back guarantee. C. MARTIN, 2431 E. 79th St., Chicago, IL 60649.

AMAZING CAR WASH—without water. Long handled, silicone treated, polishes and protects. \$3.98 plus \$1.00 postage. CHARLES MITCHELL, 900 East Julia Street, Perry, FL 32347.

START your own home operated mailorder business for under \$35.00. Details \$5¢ to Mailer, 69 Suzanne Lane, Chula Vista, CA 92011.

MAKE \$406,900 in 50 DAYS! WITH JUST A 5% RESPONSE. NO GIMMICKS! GET INVOLVED INTO CO-OP ADVERTISING AND REACH OVER SEVEN MILLION BUYERS THROUGH DIRECT MAIL! RUSH \$2.00 TO DANIEL FULLER PRODUCTS LIBRARY, P.O. BOX 5468, ASHEVILLE, NORTH CAROLINA 28803.

\$1,000.00 MONTHLY possible stuffing envelopes. National. P.O. Box 343, Randallstown, MD 21133.

For Greater Advertising Savings... Results... and Profits...

Place your ad in one of our SPECIAL COMBINATIONS: Combo #1, Combo #2 Combo #3. Each Combination is designed to give your ad the largest audience available. For further information write to R. S. Wayner, Classified Ad Manager Davis Publications, Inc. 229 Park Avenue South, New York, N.Y. 10008.

Classified Continued

OF INTEREST TO WOMEN

AMAZING Find. Collection 100-Year-Old Pioneer Recipes. Write: Mormans, 3975 Rawhide. SLC, UT 84120.

PERSONAL

JAPANESE introductions! Girls' photographs descriptions, brochure, details, \$1.00. INTER-PACIFIC Box 304-SC, Birmingham, MI 48012.

SINGLE? Widowed? Divorced? Nationwide introductions! Identity, Box 315-DC, Royal Oak, MI 48068.

"DATE WITH DIGNITY" Professional Matching. Drawer 6765, Fort Worth, 76115 (817) 921-0281 Anytime.

MAKE YOUR CLASSIFIED AD PAY. Get "How to Write A Classified Ad That Pulls." Includes certificate worth \$2.00 towards a classified ad. Send \$1.25 (includes postage) to R. S. Wayner, Davis Publications, Inc., 229 Park Avenue South, New York, N.Y. 10003.

JAPANESE Girls Make Wonderful Wives. We have large number of listings. Many interested in marriage. Only \$1.00 brings application, photos, names, descriptions, questionnaires, Etc. Japan International, Box 1181-AA, Newport Beach, CA 92663.

BEAUTIFUL MEXICAN GIRLS Wanting American Boy-Friends. Details, Photos "Free." World, Box 3876-DC, San Diego, CA 92103.

DATES GALORE! Meet singles-anywhere. Call DATELINE, toll-free (800) 451-3245.

OVER 1000 beautiful ladies photos, world's largest matrimonial catalog \$5.00. Interpass: Box 12, Toronto M4A 2M6 or Box 737, Ft. Lauderdale, FL 33302.

ADULT pleasure products—over 600 items! Giant catalog \$1.00. Clifton's, D-1068, Saugus, CA 91351.

LATIN AMERICAN GIRLS appreciate their men. Let us introduce you to a dark-eyed, unspoiled beauty. Complete application package and photo selection only \$2.00: Maria Garcia, Box 80601D, San Diego, CA 92138.

BEAUTIFUL MEXICAN GIRLS! Correspondence! Photos, information \$1.00. "Latins," Box 1716-DD, Chula Vista, CA 92012.

PHOTOGRAPHY-PHOTO FINISHING & SUPPLIES

SAVE HUNDREDS OF DOLLARS!!! Make your own S & M Densitometer. Send \$3.00 for detailed drawings and instructions. A must for successful photography in your darkroom. Order direct: S & M Instruments, Dept. EP5, 229 Park Avenue South, N.Y., N.Y. 10003.

RADIO & TV

TV TUBES 36¢ each Send for Free 48 page color catalog. Cornell, 4217-W University, San Diego, California 92105.

BI-LINEAR AMPLIFIERS: 3-30 MHz, 100 watt mobile. Construction plans, \$3.00. IGOR, Box 5516-GEB, Walnut Creek, CA 94596.

STAMP COLLECTING

ISRAEL set. Free Approvals. W-B Stamps Co., Wilkes-Barre, PA 18703.

START YOUR OWN BUSINESS

\$500-THOUSAND IMMEDIATELY, STUFFING ENVELOPES. Free supplies, rush stamped, addressed envelope. Heritage House-C, 190 Lorane Road, Reading, PA 19606.

SURPLUS EQUIPMENT

GIANT Bargain Packed Canadian Surplus Catalogs \$1.00. Etco Electronics-DG, Box 741, Montreal "A."

TIPS FOR THE HOME, ETC.

PRACTICAL tips for home, garden and workshop and in "1001 How-To Ideas." Send \$1.50 for your copy (includes postage) to 1001 How-To Ideas, 229 Park Avenue South, New York, NY 10003.

WATCHES, WATCHMAKING & REPAIRING

SAVE \$15 and more because you will never receive a parking ticket again. A watch that will keep you on schedule. It has a built-in alarm. When it's time to take your medication your alarm will remind you. It is a 17 Jewel Swiss movement gold and leather band org. \$39.95. Now \$24.95 one year service guarantee. Buy now and save. Send check to Enterprise, 2520 Newtown Ave., Long Island City, NY 11102. Allow about 3 weeks for delivery, postman will collect about \$2.00 custom duty.

Ask Hank, He Knows

(Continued from page 7)

Can You Top This One

Which antenna is most sensitive— $\frac{1}{4}$ -wave, $\frac{1}{2}$ -wave or full-wave?

—R.H., Cleveland, OH

The full-wave antenna pulls in the most signal, giving the largest possible voltage (in micro-volts) across the antenna terminal. However, imagine driving around with a full-wave CB antenna. Whereas, I heard of an SWLer in Texas who had a 30-mile-long wire antenna. Seems he strung his top rung of barbed wire on the fence using old coke bottles as insulators. Now is that a tall story, or not?

Lend a Hand

Our readers need the assistance of their fellow readers. If you can help, please write.

▲ David Gaier, Route 1, Box 3-A, Versailles, OH 45380 needs the owners manual (or copy) of the Atwater-Kent Model 33 receiver.

▲ If you have diagrams and data for the Hickok Dynamic Mutual Tester, Model 530, please write to Allan Viita, Box 174, Atiokokan, Ontario, Canada.

▲ Adelle Goldstein (Miss, Mrs. or Ms?) would like help on fixing a Radio City Products Co. Model 411 test meter. Adelle is studying electronics. Write to her at 912 Bloomfield Ave., West Orange, NJ 07712.

▲ If you have info on a Morrow MB560A transmitter and MBR-5 receiver, please write to Antonio DiBlasi, M/T Southern Sun, Sun Overseas Transport, Inc., P.O. Box 280, Claymont, Delaware.

▲ Jim Brodbeck, 138 Harvester Lane, Canton, IL would like a schematic diagram for the Knight Model 740 "Ocean Hopper" shortwave kit receiver.

▲ Earl Corey, P.O. Box 265, Matamoras, PA 18336 needs the schematic diagram and manual for the Hammarlund HQ-100C communications receiver.

▲ Do you have the info on a Navy transmitter, Type CRR-52080, Contract No. 55696, dated 30 June 1937? Please send it to Alberto J. Moreno, 3625 Agosto St., San Diego, CA 92154.

▲ Mike Schroeder, a Novice class amateur (WN8VFA) needs technical information on the Hallicrafters HT-40. Write to 37315 Ilene Drive, Mt. Clemens, MI 48043.

▲ Do you have the manual for the Heath GW-11 CB kit? Please send it to Donald Zimmerman, 975 Campbell Rd., Quincy, MI 49082.

▲ David Hach, 19955 Meadow Ridge Dr., Goshen, IN 46526 would like to get a copy of the manual and schematic diagram for the Knight Span Master 4-band radio.

▲ We need a schematic diagram of the Stereophonic Model AF-425 AM/FM radio. It's for Patrick Miller, 600 Garnet St., Apt. Y, Houghton, MI 49931.

▲ Ol' Hank is looking for any old table radio so he can restore it. If you want to part with one, write to Hank Scott in care of this magazine. ■

new and choice

Photo Darkroom Meter



□ If you've ever had trouble trying to figure out the correct exposure settings for your photographic negatives, there's a new electronic exposure meter on the market that could solve many of your enlarging problems. It promises to end guesswork, frustration and wasted time and material when you're working in the darkroom. The Model 200 darkroom meter, manufactured by PixTronics, eliminates the need for test exposure strips in B & W or color enlarging.

The meter, weighing two and a half pounds, offers many darkroom conveniences. There is an easy to read illuminated meter dial with two scales. The first is a 0-100 numerical scale with a center null point, and the second is a 0-3.0 optical density scale for direct density readings. The meter also has three sensitivity ranges for reading negatives of any density and a sensitivity control to make reference readings for fast exposure determination. The sensitivity control can also be used with an easel probe to find correct paper grades for projection printing.

The 110-volt meter is supplied with a special easel probe. The three-foot probe cable plugs into the meter. The probe has $\frac{7}{32}$ -in. and $\frac{3}{32}$ -in. apertures that can handle all exposure requirements. If you're involved in something such as ground glass photography, a cylindrical regular probe is available.

The model 200 electronic darkroom exposure meter, special easel probe and instruction manual are available by mail for \$87.50. The additional regular probe is priced at \$10.50. The manufacturer offers buyers a 15-day free trial period and a six-month guarantee. Write to: Wilfred Brown, PixTronics, 681 E. 46th St., Brooklyn, New York 11203. ■■■

New Products

(Continued from page 16)

Solderless Breadboards

Continental Specialties has two new solderless breadboarding sockets. Designated Experimentor 300 and Experimentor 600, the new one-piece sockets both provide 94 five-point terminals, plus two 40-point bus strips, for a total of 550 solderless tie-points. Experimentor 600, priced at \$10.95, has a 6/10-inch center channel, making the only socket currently on the market with full 4-terminal fan-out for microprocessors, clock chips, RAMs, ROMs and other larger DIP packages. Experimentor 300, priced at \$9.95, has a 3/10-inch center channel that is perfect for smaller DIPs. Both Experimentor sockets also accept tran-

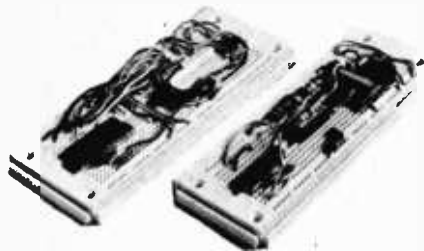

CIRCLE 41 ON READER SERVICE COUPON

sistors, LED's, resistors, capacitors, pots—virtually all types of discrete components, as well as lengths of #22-30 solid hookup wire for interconnection—with plug-in ease. Both Experimentor sockets also feature a unique interlocking system that permits sockets to be snapped together, mixed or matched, vertically or horizontally, to provide optimum configurations for almost any type of circuit, and instantly disconnected or reconnected, without tools, to meet requirements. CSC Experimentor sockets are available now from CSC distributors and dealers, or directly from CSC's East- or West-Coast offices. For more information, contact CSC at 44 Kendall St., Box 1942, New Haven, CT 06509.

16-In-One Mike

With 16 different equalization possibilities, the Shure tape recording microphone allows the user to control equalization by means of four filter switches located right on the body of the microphone. The microphone, called the Model 516EQ E-Qualidyne, has filter switches tailored to the microphone's response characteristics. For example, by activating the microphone's high frequency switch, a user can smooth out nasal and sibilant "sss" sounds. Activating the unit's low frequency switch results in the reduction of resonating "boominess." Up to 16 different combinations of switch settings change the microphone's characteristics from mellow to bright, or strengthen or de-emphasize mid-range material. The Model 516EQ E-Qualidyne also offers an excellent uni-



CIRCLE 32 ON READER SERVICE COUPON

directional pickup pattern to minimize the pickup of unwanted background noises. A highly efficient mechanical isolation mount also reduces handling and stand noises. The Model 516EQ E-Qualidyne is available singly for \$75.00 and in pairs for stereo tape recording for \$135.00. For further information, write to Shure Brothers, Inc., 222 Hartrey Avenue, Evanston, IL 60204.

Simple Security

The trouble with many anti-theft car devices is that the hookup is a lot of work. The new compact Model 3001 "Quick Connect" (Q.C.) Auto and CB Security System requires only a 3 wire hook-up to intermittently sound any car horn after illegal entry. No horn relay is required. The system is designed to protect CB radios, scanners, speakers, tape deck, stereo radios and your auto from being ripped-off by thieves. It is also for use in RVs, sports cars, and trucks. It can be installed in less than 30 minutes. The simple Q.C. alarm system is triggered by current flow caused when any light in the automobile is turned on by opening any door. If equipped with a light, the vehicle trunk or hood is



CIRCLE 42 ON READER SERVICE COUPON

also protected by the system. The System's circuitry beeps the car horn for 2½ minutes to scare-off would-be thieves. The system then shuts down and automatically rearms itself. Excessive battery drain or horn damage associated with continuous horn operation is avoided, and the system shutdown feature also eliminates the nuisance problem of accidentally tripped alarms. For further information on this mobile CB security system, available nationwide at CB and automotive distributors and sell-

ing for only \$17.95, contact Harcor International, Inc., 744 Algonquin Road, Dept. PR., Arlington Heights, IL 60005.

Fully Automatic Car Alarm

Autoalarm is a sophisticated, fully automatic, electronic alarm system based on IC logic circuitry. The Autoalarm is connected to your auto's standard electrical system and is operated by simply turning your ignition key off. There is a special holding feature that permits you to unload packages, briefcases, etc. and only arms the system after all inputs are closed. The door switch circuits activate the alarm system and you have a nominal 8 second period in which to insert and turn the ignition key. The intruder cannot turn the system off, thus causing the horn to blow in insistent intermittent blasts. If the thief attempts to remove the CB Radio or other wired accessories, or by-passes the door circuits, he causes an immediate triggering of the alarm. When the alarm is set off, the horn will blast for 2 to 3 minutes and then stop



CIRCLE 66 ON READER SERVICE COUPON

and rearm itself to protect your auto from further intrusion. Additional protection may be extended to include items such as boat trailers, pick-up tool boxes, storage compartments, etc. with optional accessory switches. A special feature provides headlight protection by blowing your horn continuously if you leave the lights on, turn off the key and open the door to leave the car. Sells for \$34.95. For further information, write to R.P.I., Inc., 13740 Midway Rd., Suite 509, Dallas, TX 75246.

Power Antique Radios

(Continued from page 82)

about 50 per cent for safety margin.

Caution. Be careful not to turn the power supply on except when there is a load across *each* output. Should the supply be operated unloaded there is a chance the output voltage at either or both outputs might rise sufficiently to overload one or all of the zeners with too much current and destroy one or more of them.

Trouble Finding Parts? You may have trouble finding a few of the parts shown in the parts list. If you do, you can substitute electrolytic capacitors by using any capacitance larger than that specified, and any working voltage higher than the ones indicated. Happy listening!

The chances are excellent that... You have a talent other people are willing to pay for!

You're "handy" around your house, have the ability to fix things, and "make them work right"... that's why there may be a rewarding career for you in Electronics.

A career in Electronics?

Absolutely. Because you're interested in *things*. How they work. Why they work. How to take them apart and put them back together. Plus . . . you've got a head for detail work.

Your chances are excellent

With the right kind of *specialized* technical training, you can have a challenging, financially rewarding future waiting for you in Electronics. Think of the career opportunities . . . computers, aerospace, 2-way radio communications, radio/TV broadcasting, medical electronics, to name just a few.

And, surprisingly, you don't need a college degree!

All you need to do to qualify for one of these exciting career fields is to build upon the technical aptitude you already have . . . just put your hands and your head to work with a CIE Electronics career course.

You learn by doing

The CIE method of instruction is the refinement of over 40 years of Electronics, independent home-study experience. It works. And you don't need *any* prior electronics experience. A CIE *career* course can take you from ground zero right up to training in Lasers, Microminiaturization, Radar, Analog Computers, and various applications in Communications.

In some CIE courses, you'll perform "hands on" experiments and tests with your own CIE Experimental Electronics Laboratory. And, if TV technology and digital Electronics are your main interest, you can select from several courses that involve working with and



troubleshooting a TV. (And the TV is yours to keep, too!) This combination of "head and hands" learning *locks in* your understanding of the crucial principles you'll use on-the-job in your new career. But, don't kid yourself . . .

Electronics is not an "easy" science and CIE courses are not "snaps." Subject matter is technical, thorough, and challenging. It has to be. We're training you for a *career*. So the presentation of ideas is logical, written in easy-to-understand language . . . you progress step-by-step, at your own pace.

CIE Education by mail

There is no need to "go back to the classroom" with CIE. Because you learn at *home* or wherever else is convenient. You keep your present job and income. No cross-town commutes. *You* decide when and where *you* study best.

Your eventual success . . . at CIE and in your electronics career . . . will be determined by your own motivation and self-discipline. You *can* do it. And CIE can show you how.

Put your talent to full use

We believe that you may be a "natural" for Electronics, and we'd like to tell you more about potential career fields and our school. We'll be glad to send you our complete package of FREE career information if you'll send in the card or coupon or write CIE (include name and date of this publication), 1776 E. 17th St., Cleveland OH 44114. For your convenience, we'll try to have a school representative call to assist you in course selection. As soon as we receive your request, we'll mail you our school catalog, complete G.I. Bill details and booklet on FCC License preparation.

There's no obligation.

Let's discuss your new career in Electronics, NOW! Send for your FREE school catalog and career information TODAY.

CIE Cleveland Institute of Electronics, Inc.

1776 East 17th Street, Cleveland, Ohio 44114

Accredited Member National Home Study Council

Yes, I want your FREE school catalog and career information package.

OE-10

Print Name _____

Address _____ Apt. _____

City _____ State _____ Zip _____

Age _____ Phone (Area Code) _____ No. _____

Check box for G.I. Bill information: Veteran On Active Duty

BUILD 20 RADIO and Electronics Circuits

Reg. U. S.
Pat. Off.



Training Electronics Technicians Since 1946

PROGRESSIVE HOME RADIO-T.V. COURSE

Now Includes

- ★ 12 RECEIVERS
- ★ 3 TRANSMITTERS
- ★ SQ. WAVE GENERATOR
- ★ SIGNAL TRACER
- ★ AMPLIFIER
- ★ SIGNAL INJECTOR
- ★ CODE OSCILLATOR

- ★ No Knowledge of Radio Necessary
- ★ No Additional Parts or Tools Needed
- ★ Solid State Circuits
- ★ Vacuum Tube Circuits

YOU DON'T HAVE TO SPEND HUNDREDS OF DOLLARS FOR A RADIO COURSE

The "Edu-Kit" offers you an outstanding PRACTICAL HOME RADIO COURSE at a rock-bottom price. Our Kit is designed to train Radio & Electronics Technicians, making use of the most modern methods of home training. You will learn radio theory, construction practice and servicing. THIS IS A COMPLETE RADIO COURSE IN EVERY DETAIL.

You will learn how to build radios, using regular schematics; how to wire and solder in a professional manner; how to service radios. You will work with the standard type of punched metal chassis as well as the latest development of Printed Circuit chassis.

You will learn the basic principles of radio. You will construct, study and work with RF and AF amplifiers and oscillators, detectors, rectifiers, test equipment. You will learn and practice code, using the Progressive Code Oscillator. You will learn and practice trouble-shooting, using the Progressive Signal Tracer, Progressive Signal Injector, Progressive Dynamic Radio & Electronics Tester, Square Wave Generator and the accompanying instructional material.

You will receive training for the Novice, Technician and General Classes of F.C.C. Radio Amateur Licenses. You will build Receiver, Transmitter, Square Wave Generator, Code Oscillator, Signal Tracer and Signal Injector circuits, and learn how to operate them. You will receive an excellent background for television, Hi-Fi and Electronics.

Absolutely no previous knowledge of radio or engineering is required. The "Edu-Kit" is the product of many years of teaching and engineering experience. The "Edu-Kit" will provide you with a basic education in Electronics and Radio, worth many times the low price you pay. The Signal Tracer alone is worth more than the price of the kit.

THE KIT FOR EVERYONE

You do not need the slightest background in radio or science. Whether you are interested in Radio & Electronics because you want an interesting hobby, a well paying business or a job with a future, you will find the "Edu-Kit" a worth-while investment. Many thousands of individuals of all

ages and backgrounds have successfully used the "Edu-Kit" in more than 79 countries of the world. The "Edu-Kit" has been carefully designed, step by step, so that you cannot make a mistake. The "Edu-Kit" allows you to teach yourself at your own rate. No instructor is necessary.

PROGRESSIVE TEACHING METHOD

The Progressive Radio "Edu-Kit" is the foremost educational radio kit in the world, and is universally accepted as the standard in the field of electronics training. The "Edu-Kit" uses the modern educational principle of "Learn by Doing." Therefore you construct, learn schematics, study theory, practice trouble shooting—all in a closely integrated program designed to provide an easily-learned, thorough and interesting background in radio.

You begin by examining the various radio parts of the "Edu-Kit." You then learn the function, theory and wiring of these parts. Then you build a simple radio. With this first set you will enjoy listening to regular broadcast stations, learn theory, practice testing and trouble-shooting. Then you build a more advanced radio, learn more advanced theory and techniques. Gradually, in a progressive manner, and at your own rate, you will find yourself constructing more advanced multi-tube radio circuits, and doing work like a Professional Radio Technician.

Included in the "Edu-Kit" course are Receiver, Transmitter, Code Oscillator, Signal Tracer, Square Wave Generator and Signal Injector Circuits. These are not unprofessional "breadboard" experiments, but genuine radio circuits, constructed by means of professional wiring and soldering on metal chassis, plus the new method of radio construction known as "Printed Circuitry." These circuits operate on your regular AC or DC house current.

THE "EDU-KIT" IS COMPLETE

You will receive all parts and instructions necessary to build twenty different radio and electronics circuits, each guaranteed to operate. Our Kits contain tubes, tube sockets, variable, electrolytic, mica, ceramic and paper dielectric condensers, resistors, tie strips, hardware, tubing, punched metal chassis, Instruction Manuals, hook-up wire, solder, selenium rectifiers, coils, volume controls, switches, solid state devices, etc.

In addition, you receive Printed Circuit materials, including Printed Circuit chassis, special tube sockets, hardware and instructions. You also receive a useful set of tools, a professional electric soldering iron, and a self-powered Dynamic Radio and Electronics Tester. The "Edu-Kit" also includes Code Instructions and the Progressive Code Oscillator, in addition to F.C.C. Radio Amateur License training. You will also receive lessons for servicing with the Progressive Signal Tracer and the Progressive Signal Injector, a High Fidelity Guide and a Quiz Book. You receive Membership in Radio-TV Club, Free Consultation Service, Certificate of Merit and Discount Privileges. You receive all parts, tools, instructions, etc. Everything is yours to keep.

FREE EXTRAS

• SET OF TOOLS

- SOLDERING IRON
- ELECTRONICS TESTER
- PLIERS-CUTTERS
- VALUABLE DISCOUNT CARD
- CERTIFICATE OF MERIT
- TESTER INSTRUCTION MANUAL
- HIGH FIDELITY GUIDE • QUIZZES
- TELEVISION BOOK • RADIO
- TROUBLE-SHOOTING BOOK
- MEMBERSHIP IN RADIO-TV CLUB:
- CONSULTATION SERVICE FCC
- AMATEUR LICENSE TRAINING
- PRINTED CIRCUITRY

SERVICING LESSONS

You will learn trouble-shooting and servicing in a progressive manner. You will practice repairs on the sets that you construct. You will learn symptoms and causes of trouble in home, portable and car radios. You will learn how to use the professional Signal Tracer, the unique Signal Injector and the dynamic Radio & Electronics Tester. While you are learning in this practical way, you will be able to do many a repair job for your friends and neighbors, and charge fees which will far exceed the price of the "Edu-Kit." Our Consultation Service will help you with any technical problems you may have.

FROM OUR MAIL BAG

J. Stataitis, of 25 Poplar Pl., Waterbury, Conn., writes: "I have repaired several sets for my friends, and made money. The "Edu-Kit" paid for itself. I was ready to spend \$240 for a Course, but I found your ad and sent for your Kit."

Ben Valerio, P. O. Box 21, Magna, Utah: "The Edu-Kits are wonderful. Here I am sending you the questions and also the answers for them. I have been in Radio for the last seven years, but like to work with Radio Kits, and like to build Radio Testing Equipment. I enjoyed every minute I worked with the different kits; the Signal Tracer works fine. Also like to let you know that I feel proud of becoming a member of your Radio-TV Club."

Robert L. Shuff, 1534 Monroe Ave., Huntington, W. Va.: "Thought I would drop you a few lines to say that I received my Edu-Kit, and was really amazed that such a bargain can be had at such a low price. I have already started repairing radios and phonographs. My friends were really surprised to see me get into the swing of it so quickly. The Trouble-shooting Tester that comes with the Kit is really swell, and finds the trouble, if there is any to be found."

PRINTED CIRCUITRY

At no increase in price, the "Edu-Kit" now includes Printed Circuitry. You build a Printed Circuit Signal Injector, a unique servicing instrument that can detect many Radio and TV troubles. This revolutionary new technique of radio construction is now becoming popular in commercial radio and TV sets.

A Printed Circuit is a special insulated chassis on which has been deposited a conducting material which takes the place of wiring. The various parts are merely plugged in and soldered to terminals.

Printed Circuitry is the basis of modern Automation Electronics. A knowledge of this subject is a necessity today for anyone interested in Electronics.

Progressive "Edu-Kits" Inc., 1189 Broadway, Dept. 509FC Hewlett, N.Y. 11557

Please rush me free literature describing the Progressive Radio-TV Course with Edu-Kits. No Salesman will call.

NAME

ADDRESS

CITY & STATE ZIP

PROGRESSIVE "EDU-KITS" INC.

1189 Broadway, Dept. 509FC

Hewlett, N.Y. 11557

CIRCLE 8 ON READER SERVICE COUPON