

Morgan

E RADIO & **E**LECTRONICS **W**ORLD

AUSTRALIA \$2.95c
CANADA £1.26½p
EIRE \$2.20c
NEW ZEALAND F7.15
HOLLAND

85p

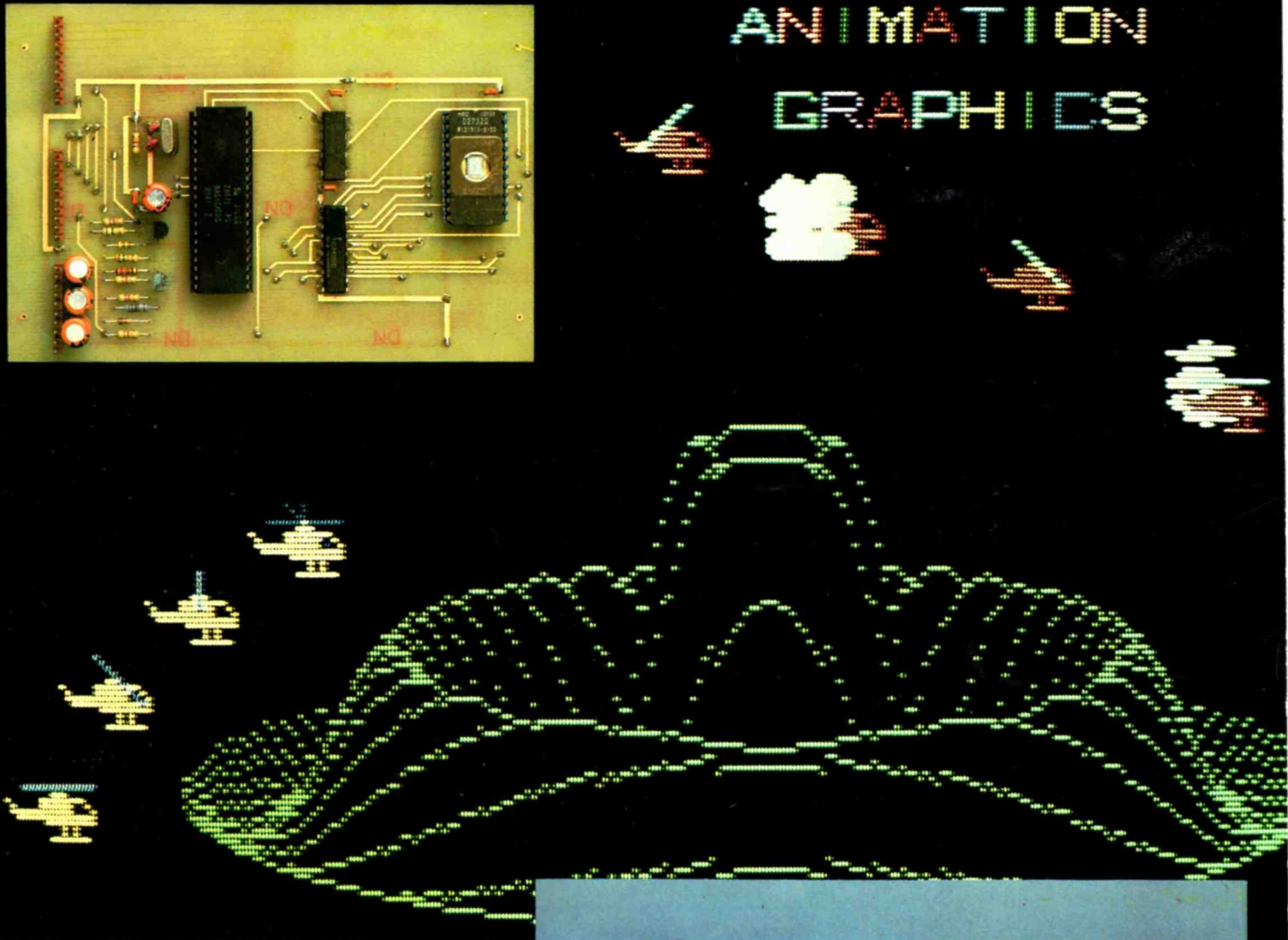
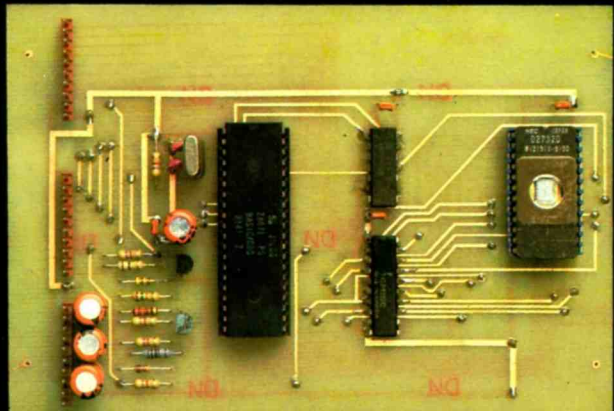

PROJECTS
Minimum Chip Z8 System
REVIEWS
Morse Trainer
FEATURES
SAW Filters Explained



SOMEDAY, ALL COMPONENTS WILL BE SOLD THIS WAY!



*The telephone accessible
information service for
the WORLD OF RADIO
ELECTRONICS, computing,
communications and
video*

- * Catalogue support information, news, bulletins, electronics news.
- * Ordering by 'phone (soon to be on-line)
- * Free access to 'public' areas. £10pa gets you into the 'special' features.

**REW
TEL**

The 24 hour service will commence when the phone lines are available!

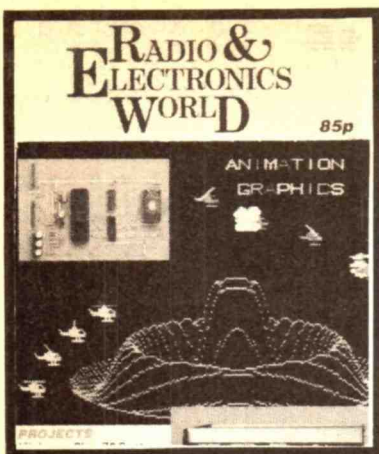

R&EW

JANUARY 1983

Volume 2 No.4

Contents

Projects

Minimum Chip Z8 Board	- (Almost) naked Z8	10
10M Transverter	- Based on our 6M design	30
TX9 monitor conversion	- Last in our series	34
CMOS Keyer	- Paddle with Bailey	44
Graphics Board	- For the Nascom and other Z80 systems	59
R&EW Transceiver	- The control module	67
Noise Squelch	- Further installation details	70
Circuit Block	- A handy resistance box	72

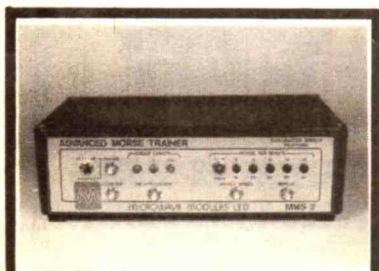
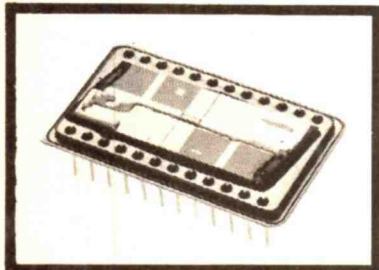
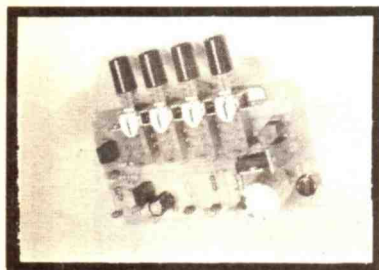
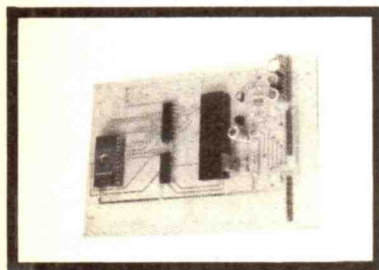
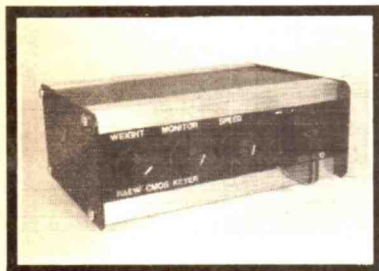

Features

Comment	- All change	5
Data Brief: NE 5553	- Dual voltage regulator	25
The Story of Z	- Complex resistance made simple	27
Designers Update	- More from the Data books	40
SAW Filters Explained	- Making waves	48
Data Brief: 20W Audio Amp	- In depth analysis	53
Rewtel Directory	- Useful Rewtel words	55
Audio Brief	- analysis in depth	56
Letters Page	- Airing your views	79
Sounding Off	- Evan Steadman's page	80
Note From The Past	- Electronics circa 1950	81
Data File	- More circuits than words	89
Last Word	- Le Crunch	96

Reviews

ICOM IC730	- Poel probes and reports	15
MMS2 Morse Trainer	- Speaking morse machine	21
Panasonic 7800	- Stereo video	75

News

New Products	- Market update	6
Computing News	- Bits of news	20
Video News	- The low down on video	32
News Background	- Computer pirates	71
Feedback	- Correcting our errors	74
DX-TV	- Channel 4 and beyond	84
Short Wave News	- An old favourite	86

Information

Next Month's R&EW	- With free gift	24
R&EW Book Service	- Ever growing selection	83
Advertisers Index	- Turn to page ...	96

MODULES FOR SECURITY & MEASUREMENT

As featured in PRACTICAL ELECTRONICS

INTRUDER ALARM CONTROL UNIT CA 1250

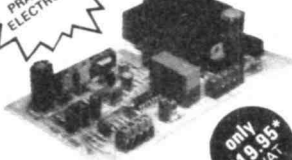

only £18.95 + VAT

This exciting new module offers all the possible features likely to be required when building an intruder alarm system. Whether used with only 1 or 2 magnetic switches or in conjunction with several ultrasonic alarm modules or infra-red units, a really effective system can be constructed at a fraction of the cost of comparable ready-made units. Supplied with a fully explanatory Data Sheet that makes installation straight forward, the module is fully tested and guaranteed.

*available in kit form £16.95 plus VAT.

- Built-in electronic siren drives 2 loud speakers
- Provides exit and entrance delays together with fixed alarm time
- Battery back-up with trickle charging facility
- Operates with magnetic switches, u/sonic or I.R. units
- Anti-tamper and panic facility
- Stabilised output voltage
- 2 operating modes - full alarm/anti-tamper and panic facility
- Screw connections for ease of installation
- Separate relay contacts for switching external loads
- Test loop facility

DIGITAL VOLTMETER MODULE DVM 314

Fully built & tested



only £11.95 + VAT

- Positive & negative voltage with an FSD of 999mV which is easily extended
- Requires only single supply 7-12V
- High overall accuracy - 0.1% + 1 digit
- Large bright 0.43" LED displays
- Supplied with full applications data

With this fully built and calibrated module a wide range of accurate equipment such as multimeters, thermometers, battery indicators etc. can be constructed at a fraction of the cost of ready-made units. Full details are supplied for extending the voltage range, measuring current, resistance and temperature. Fully guaranteed, the unit has been supplied to electricity authorities, Government departments, etc.

Temperature Measurement Kit DT.10

£2.25 + VAT

Using the I.C. probe supplied, this kit provides a linear output of 10mV/°C over the temperature range from -10°C to +100°C. The unit is ideal for use in conjunction with the DVM module providing an accurate digital thermometer.

Power Supply PS.209

£4.95 + VAT

This fully built mains power supply provides two stabilised isolated outputs of 9V, 250mA each. The unit is ideally suited for operating the DVM and Temperature Measurement module.

ULTRASONIC ALARM MODULE US 4012

Fully built & tested

only £10.35 + VAT

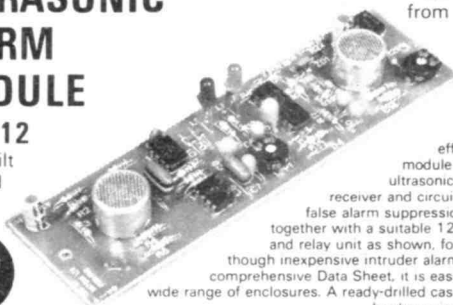

Adjustable range from 5ft. to 25ft.

A really effective fully built module containing both ultrasonic transmitter and receiver and circuitry for providing false alarm suppression. This module, together with a suitable 12V power supply and relay unit as shown, forms an effective though inexpensive intruder alarm. Supplied with comprehensive Data Sheet, it is easily mounted in a wide range of enclosures. A ready-drilled case and necessary hardware is available below.

Power Supply & Relay Units PS 4012

£4.25 + VAT

Provides a stabilised 12V output and relay with 3A contacts. The unit is designed to operate one or two of the above ultrasonic units. Fully built and tested.

Hardware Kit HW 4012

£4.25 + VAT

A suitable ready-drilled case with the various mounting pillars, mains switch socket and nuts and bolts. Designed to house the ultrasonic alarm module together with its power supply. Size: 153mm x 120mm x 45mm.

Siren Module SL 157

£2.95 + VAT

Produces a loud and penetrating sliding tone operating from 9-15V. Capable of driving 2 off 8 ohm speakers to SPL of 110db at 2M. Contains an inhibit facility for use with shop lifting loops or other break to activate circuits.

ACCESSORIES

- 3-position Key Switch for use with CA 1250, supplied with 2 keys £3.43
- Magnetic switch (with magnet) £1.17
- 5" Horn speaker for use with SL 157 £4.95

Add VAT & 50p post and packing to all orders.

Shop hours 9.00 - 5.30 p.m. (Wed. 9.00 - 1.00 p.m.)

Units on demonstration - callers welcome. S.A.E. with all enquiries.



RISCOMP LIMITED

Dept: REW 12

21 Duke Street, Princes Risborough, Bucks. Princes Risborough (084 44) 6326

148 for further details

PORTABLE MAINS DISTRIBUTION NOW WITH EARTH LEAKAGE

OLSON

FOR INSTANT MAINS DISTRIBUTION IN OFFICES, LABORATORIES, WORKSHOPS AND FOR MAXIMUM SAFETY

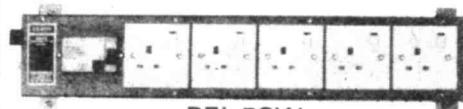

BEL 5SW
£61, £2.25 P&P + VAT



PEL 1
£44.50, £1.50 P&P + VAT



N13A/6
£23.40, £1.50 P&P + VAT



13A/4SW
£22.40, £1.50 P&P + VAT

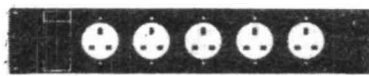

13A/5/R £25.30, £1.50 P&P + VAT



PEL 3
£65, £2.25 P&P + VAT



WEL 2
£52.80, £2.25 P&P + VAT

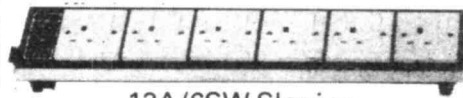

13A/6SW Slopinq
£26, £1.50 P&P + VAT



T13A/5
£21.75
£1.50 P&P + VAT

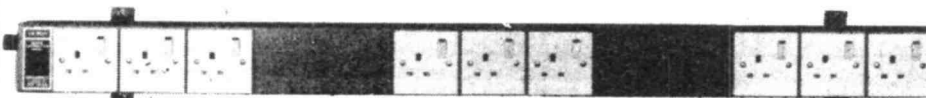

TR9 £38.75, £2.50 P&P + VAT

N13A/3
£16.77, £1.50 P&P + VAT

DELIVERY EX-STOCK

OLSON

Electronics Ltd.

FACTORY NO. 8, 5-7 LONG STREET
LONDON E2 8HJ Tel: 01-739 2343



149 for further details

Double Top

This new addition to the Eddystone range of diecast boxes is supplied with interchangeable deep or shallow, close-fitting flanged lids giving flexibility of application with minimum stocking.

Please write or telephone for details of the new, versatile 10758P box. And ask about the whole Eddystone range of strong, lightweight, corrosion-resistant, diecast aluminium boxes, water-resistant boxes and moulded ABS plastic boxes, in a range of sizes to meet a thousand applications.

STOP PRESS!

The flexibility of deep/shallow and base lids has now been extended to a number of standard sizes.

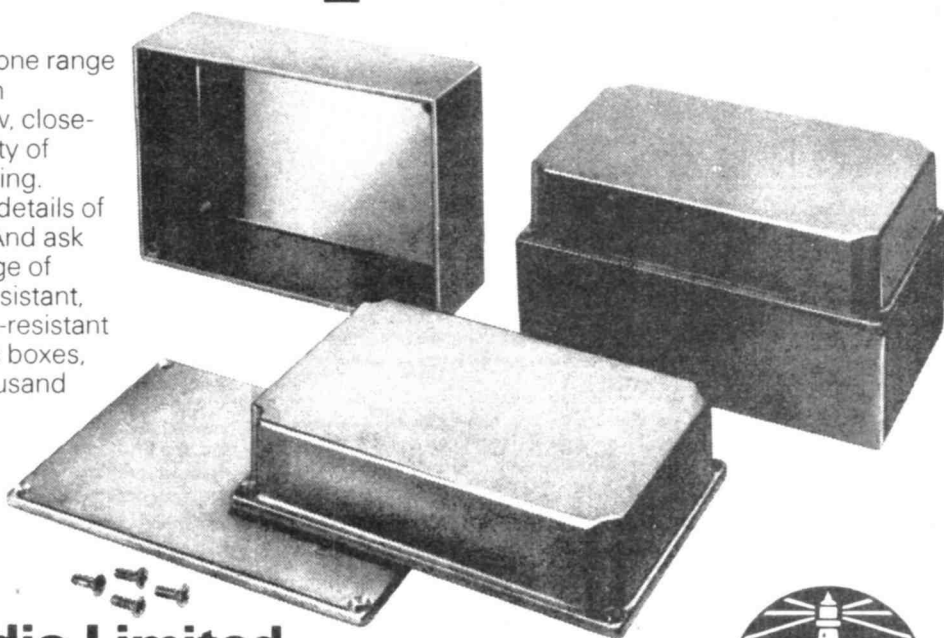

Eddystone Radio Limited

Member of Marconi Communication Systems Limited

Alvechurch Road, Birmingham B31 3PP, England
Telephone: 021-475 2231 Telex: 337081

A GEC Marconi Electronics Company



150 for further details

THE LEXTON 7 AMP & 20 AMP POWER SUPPLY

SPECIFICATIONS

OUTPUT: Nominal 13.8 Volts at D.C.
REGULATION: Better than 0.15 Volts from no load to full load. (At R.M.S. rating)
RIPPLE: Better than 30 mv at 100Hz on full load. (R.M.S. ratings)
PROTECTION: Electronic over Voltage and Current. Temperature protected for internal shorts.
INPUT: 220 or 240 Volts A.C. at 40 to 60 Hz. Other voltages on request.

7AMP
£49.95

FEATURES

- ★ Power on demand
- ★ No warm-up time
- ★ Current sense feed back circuit
- ★ Over rated output transistors
- ★ Peak output 10% over R.M.S. ratings
- ★ Power output indicator fitted
- ★ High power to weight ratio
- ★ Very low R.F.I.
- ★ Only mains on/off switch, no other controls
- ★ Excellent temperature stability
- ★ Full linear design
- ★ RF Toroidal fitted to prevent RF damage to the unit or regulation
- ★ Under voltage shut-down fitted

20AMP
£79.95

TRADE ENQUIRIES WELCOME

H. LEXTON LIMITED
G4JDT

191 FRANCIS ROAD LEYTON E.10
TEL 01-558 0854 TELEX 8953609 LEXTON G

151 for further details

electronize

ELECTRONIC IGNITION KITS OR READY BUILT

IS YOUR CAR AS GOOD AS IT COULD BE ?

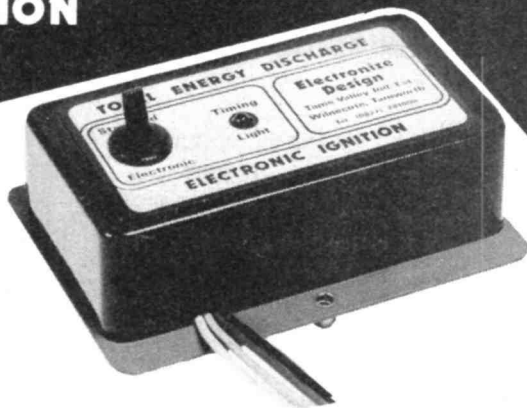

- ★ Is it **EASY TO START** in the cold and the damp? Total Energy Discharge will give the most powerful spark and maintain full output even with a near flat battery.
- ★ Is it **ECONOMICAL** or does it "go off" between services as the ignition performance deteriorates? Total Energy Discharge gives much more output and maintains it from service to service.
- ★ Has it **PEAK PERFORMANCE** or is it flat at high and low revs. where the ignition output is marginal? Total Energy Discharge gives a more powerful spark from idle to the engines max. (even with 8 cylinders).
- ★ Is the **PERFORMANCE SMOOTH**. The more powerful spark of Total Energy Discharge eliminates the 'near misfires' whilst an electronic filter smooths out the effects of contact bounce etc.
- ★ Do the **PLUGS and POINTS** always need changing to bring the engine back to its best. Total Energy Discharge eliminates contact arcing and erosion by removing the heavy electrical load. The timing stays "spot on" and the contact condition doesn't affect the performance either. Larger plug gaps can be used, even wet or badly fouled plugs can be fired with this system.

Most **NEW CARS** already have **ELECTRONIC IGNITION**. Update **YOUR CAR** with the most powerful system on the market - 3½ times more spark power than inductive systems - 3½ times the spark power of ordinary capacitive systems, 3 times the spark duration.

Total Energy Discharge also features:
EASY FITTING, STANDARD/ELECTRONIC CHANGE-OVER SWITCH, LED STATIC TIMING LIGHT, LOW RADIO INTERFERENCE, CORRECT SPARK POLARITY and DESIGNED IN RELIABILITY.

- ★ **IN KIT FORM** it provides a top performance system at less than half the price of competing ready built units. The kit includes: pre-drilled fibreglass PCB, pre-wound and varnished ferrite transformer, high quality 2µF discharge capacitor, case, easy to follow instructions, solder and everything needed to build and fit to your car. All you need is a soldering iron and a few basic tools.

FITS ALL NEGATIVE EARTH VEHICLES

6 or 12 volt, with or without ballast.

OPERATES ALL VOLTAGE IMPULSE TACHOMETERS:

(Older current impulse types need an adaptor).

STANDARD CAR KIT £15.90
Assembled and Tested £26.70

PLUS
P. & P.
£1 (U.K.)

TWIN OUTPUT KIT £24.55
For Motor Cycles and Cars with twin ignition systems
Assembled and Tested £36.45

Prices
include
VAT



ELECTRONIZE DESIGN

Dept. C · Magnus Rd · Wilnecote
Tamworth · B77 5BY
tel: 0827 281000

The basic function of a spark ignition system is often lost among claims for longer "burn times" and other marketing fantasies. It is only necessary to consider that, even in a small engine, the burning fuel releases over 5000 times the energy of the spark, to realise that the spark is only a trigger for the combustion. Once the fuel is ignited the spark is insignificant and has no effect on the rate of combustion. The essential function of the spark is to start that combustion as quickly as possible and that requires a high power spark.

The traditional capacitive discharge system has this high power spark but, due to its very short spark duration and consequential low spark energy, is incompatible with the weak air/fuel mixtures used in modern cars. Because of this most manufacturers have abandoned capacitive discharge in favour of the cheaper inductive system with its low power but very long duration spark which guarantees that sooner or later the fuel will ignite. However, a spark lasting 2000µS at 2000 rev/min. spans 24 degrees and 'later' could mean the actual fuel ignition point is retarded by this amount.

The solution is a very high power, medium duration, spark generated by the TOTAL ENERGY DISCHARGE system. This gives ignition of the weakest mixtures with the minimum of timing delay and variation for a smooth efficient engine.

- ★ **SUPER POWER DISCHARGE CIRCUIT** A brand new technique prevents energy being reflected back to the storage capacitor, giving 3½ times the spark energy and 3 times the spark duration of ordinary C.D. systems, generating a spark powerful enough to cause rapid ignition of even the weakest fuel mixtures without the ignition delay associated with lower power 'long burn' inductive systems.
- ★ **HIGH EFFICIENCY INVERTER** A high power, regulated inverter provides a 370 volt energy source - powerful enough to store twice the energy of other designs and regulated to provide sufficient output even with a battery down to 4 volts.
- ★ **PRECISION SPARK TIMING CIRCUIT** This circuit removes all unwanted signals caused by contact volt drop, contact shuffle, contact bounce, and external transients which, in many designs, can cause timing errors or damaging un-timed sparks. Only at the correct and precise contact opening is a spark produced. Contact wear is almost eliminated by reducing the contact breaker current to a low level - just sufficient to keep the contacts clean.

TYPICAL SPECIFICATION

	Total Energy Discharge	Ordinary Capacitive Discharge
SPARK POWER (Peak)	140W	90W
SPARK ENERGY	36mJ	10mJ
STORED ENERGY	135mJ	65mJ
SPARK DURATION	500µS	160µS
OUTPUT VOLTAGE (Load 50pF, equivalent to clean plugs)	38kV	26kV
OUTPUT VOLTAGE (Load 50pF + 500k, equivalent to dirty plugs)	26kV	17kV
VOLTAGE RISE TIME TO 20kV (Load 50pF)	25µS	30µS

TOTAL ENERGY DISCHARGE should not be confused with low power inductive systems or hybrid so called reactive systems.

Comment

Editorial Offices

117a High Street, Brentwood, Essex
CM14 4SG

Editorial (0277) 213819

Managing Editor

William Poel

Editor

Gary Evans

Assistant Editor

Paul Coster

Computing Editor

Jonathan C Burchell

Technical Consultants;

Projects

Keith Collins

Communications

Graham Leighton

Roger Ray

Production (0277) 230909 EX 34

Production Editor

Jack Burrows

Design Consultant

Patrick Haylock

Art Editor

Sally Bennett

Layout

Helen White

Martin Sheehan

Editorial Secretaries

Kim Mitchell

Janet Capon

Advertising (0277) 213819

Advertisement Manager

John White

Subscription 01-868 4854

Subscription Manager

Owen Rundle

45 Yeading Avenue, Rayners Lane,

Harrow, Middx HA2 9RL

Subscription Rate

UK £13.00 p.a.

O/Seas £13.50 p.a.

Printers

LSG Printers, Lincoln

Photosetting by

Method Ltd

Distributors 01-274 8611

SM Distribution Ltd

Overseas Agents

Holland Electronics 071-218822

Postbus 377, 2300 A J LEIDEN

U.S. PROJECT PACK AGENTS

Box 411, Greenville, New Hampshire
NH030408, U.S.A.

Back Issues: £1 each inclusive of postage
from Subscription Dept. or send reply paid
card with cheque or PO.

© Broadcasting Limited 1983. All
reasonable precautions are taken by R&EW
to ensure that the information given to our
readers is reliable. However we cannot
guarantee it and we cannot accept legal
responsibility for it. Information and prices
are correct at time of going to press.

Reproduction of contents is possible with
permission from the Editor, however short
abstracts or references are allowable
providing the source is given.

Publishers Broadcasting Limited

Now that our very own phone-in computer service is beginning to warm up (sorry if you're having to wait to get access, pay the subs and we can afford some more lines, and maybe issue secret numbers to paid subscribers, eh?), and the year of Information Technology is past, how about a small New Year gift from Kenneth Baker?

Like a more liberal system of charging telephone lines used in pursuit of IT. The USA has a very enlightened system known as the WATS line, where the subscriber pays a rental to receive incoming calls from all over the USA. These numbers (coded 800) are widely used as sales lines, and lines to telephone data bases, where the user doesn't have to worry about the outrageous call charges we suffer in the UK.

The temptation to monopolize the call line could be cured by a time-out system, which operates to disconnect the incoming caller at the exchange (you cannot disconnect an incoming call simply by hanging up under the current system). There's certainly no shortage of technological 'ways' - if there's a political will in the first place. And what a huge boost to phone-in data information services if the callers could then overcome their phobia of Buzby's excesses.

Maybe even Prestel could benefit from such a concept?

The more observant amongst you will notice a few subtle changes to R&EW this month. The first is that Roland Perry has now taken over responsibility for the REWTEL service. Since first trials began in the summer, the number of people using REWTEL has grown from a couple of eager experimenters to the current situation in which the REWTEL line is in almost constant use.

The data base has now grown to a considerable size and the task of ensuring that it is continually updated and revised is now a full time job. Roland Perry, with his REWTEL Editor's hat on, has taken on the task and any enquiries regarding the service should be directed to him via our Editorial Offices.

The other change in this issue is the way in which R&EW Project Packs are marketed. In the past our kits and PCBs have been sold under the R&EW flag. From this month on we have arranged for Ambit International to take over responsibility for Project Packs.

This change has again been necessitated by the continual increase in demand for Project Packs which has meant that R&EW's staff have begun to feel the strain of processing the orders as well as getting on with the job of producing the magazine.

Ambit, who regularly advertise in R&EW, have the facilities to efficiently deal with Project Packs and the new arrangement should see a speedier dispatch of Project Packs. See Ambit's advert on page 73 for details of this new service and address all future enquiries regarding kits to them at 200, North Service Road, Brentwood, Essex CM14 4SG.

APOLOGIES

Last month the REWTEL advert on our back cover showed a telephone number that was definitely NOT REWTEL's.

We are sorry for the inconvenience that this caused the people at the receiving end of the calls destined for REWTEL and for those users of the REWTEL system that were confused by the error.

For the record the REWTEL number is 0277 230959, that's 230959, outside office hours.

From next month however, we'll offer a full 24hr service. More details in our February issue.

BURNS

EVER CHECKED YOUR FREQUENCY COUNTER?

Calibrate it, or other Test Gear, with our new Off-Air Frequency Standard SD-12. Locked to the BBC 200 KHz Transmitter at Droitwich but readily convertible to 198 KHz when the BBC changes the Droitwich

Accuracy 1 Hz in 10 MHz. Output at 10 MHz and 1 MHz.

Used by British Telecommunications and other Authorities.

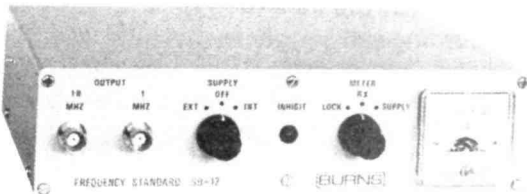

We still supply matching Crystal Calibrators CC-11 and Absorption Wavemeters TC-101 as previously advertised.

Contact us at our New Address:- BURNS ELECTRICS, 170a, Oval Rd, Croydon, Surrey. CRO 6BN Telephone 01-680-1585

153 for further details.

A LIGHTING REVOLUTION!

● DIRECT FROM THE MANUFACTURERS COMES A BREAKTHROUGH IN LIGHTING TECHNOLOGY AND PRICE!

SYSTEMS FROM JUST £214

- 6 channel hand held controller £70
- 12 channel 2 preset desks £180
- 18 channel 2 preset desks £260
- 6 channel 13A power packs £120
- 10 metre multi-core cables £12

(prices do not include VAT and delivery)

THE MINI-12
Compact 2-preset
blue/black desks.

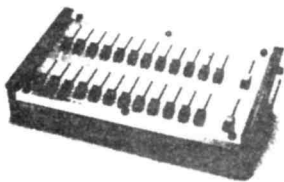

THE MICRODIM PACK

An ideal method of providing 6 channels that plug easily and quickly to your lamps, the mains and the desk. Can be free-standing or wall mounting. Complete with 10M mains lead.

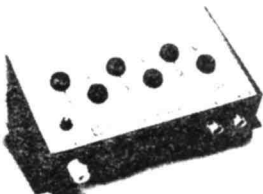

After extensive research MJL have arrived at a means to provide the complete lighting versatility you require, at a price you can afford. ITS CALLED DIGI-DIM TECHNOLOGY. Out goes the expensive voltage control method and in comes the micro-chip. If your requirement is for amateur or professional theatre, mobile or fixed lighting rigs, rock bands, or simply general purpose, then waste no more time and phone or write for FREE information to:

MJL SYSTEMS LTD. (Dept A)
45 Wortley Road, W. Croydon, Surrey CR0 3EB, U.K.
Tel: 01-689 4138
Our sales desk is open Mons to Frids 9.30-5.30

154 for further details

NEW PRODUCTS

Pico Knows Best

As components in the micro-electronics world become smaller, so must the accessories to be used with them. One such accessory is the new EZ Hook test probe, which measures barely 1" in length. Introduced into the UK by I & J Products of Ringwood, Hants, as a preview to the American manufacturer's launch in that country, the Pico Hook is the result of market research amongst users of the EZ Hook range.

The diminutive size and weight, mean the Pico Hook is only available prewired (with a choice of 28 AWG or Teflon wire): wiring up the head would be too tedious for most engineers' fingers. However, the famous "hypodermic" action of all EZ Hooks continues in the moulded nylon body of the Pico Hook. The hook and spring loading are manufactured with gold-plated beryllium copper and stainless steel respectively.



The Pico Hook is available in ten colour-codings (as is the lead), which can be supplied attached to lead only, or connected to .025 square socket, .025 pin or a second Pico Hook.

I & J Products Ltd.,
7a Christchurch Road,
RINGWOOD,
Hants.

Perpendicular Floppy

A small floppy disk drive, that's large in capacity, has been developed by the Toshiba Corporation.

Using perpendicular magnetic recording, it marks the world's first simultaneous development of disk media and disk drive for reading and writing information.

The new floppy disk can record three megabytes of information on a 3.5" diameter disk. Recording density is about 27 times that of the conventional longitudinal recording floppy disk drive, now on the market.

Perpendicular magnetic recording, which stores information perpendicularly to the recording medium, permits much higher recording density than the longitudinal recording now used. The method, proposed and experimentally verified by Professor Iwasaki of Tohoku University in 1975, is one of the most advanced basic technologies developed in Japan. Since then, Japanese and foreign manufacturers have been seeking ways to put this new

technology into practical use.

The floppy disk medium is made by sputtering particles of magnetic material, on a plastic film. Toshiba, using its own technology, succeeded in forming a 0.5-micron layer - homogeneous and smooth - on each side of a polyester base film.

The disk drive carries newly developed devices, like a 0.4 μm gap high resolution ring-shaped head, a precise disk centering mechanism and an accurate head positioning mechanism. The use of a ring-shaped head allows a simple structure for the head positioning mechanism, together with the possibility of recording information on both sides of the disk. It also permits the use of Co/Cr single layered recording media, which simplifies the manufacturing process.

Using these newly developed devices, the perpendicular recording floppy disk drive attained a nine times higher linear recording density (50 kBPI), a three times higher track density (144 TPI) and, consequently, a 27 times higher recording density in comparison with the conventional disk drive.

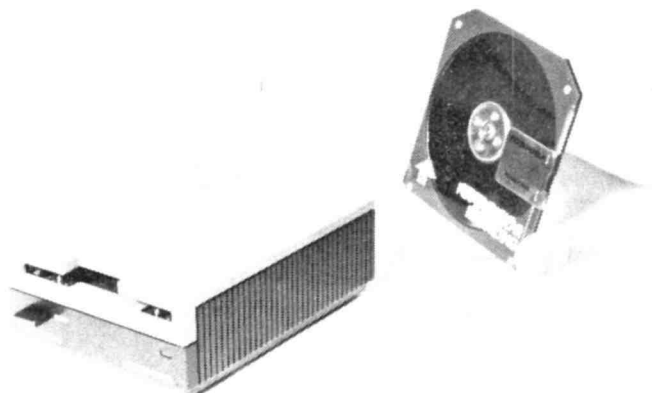

RADIO & ELECTRONICS WORLD

Growing With UNIX

By developing computer-based solutions to problems on the UNIX operating system, a newly-formed British company, Amexon Communication and Computer Systems Limited have created a flexible hardware "Growth Path" enabling users to graduate from time-sharing requirements to high performance 'super-micros'.

Amexon's unique "Growth Path" approach means that the user now has the freedom to upgrade his hardware facilities at any time, while retaining the benefit of his investment in operational experience, staff training and the smooth running of his information processing and administration systems.

A major factor in the success of Amexon's "Growth Path" philosophy is the availability of two high quality programming languages, RMCOBOL and CBASIC. These offer extensive application software facilities and provide portability

UNIX System III. Each of Amexon's PLEXUS 'super-micros' is capable of supporting up to 100 time-sharing users operating VDU's from their own premises via an acoustic coupler.

Amexon's second solution, the supply of single-user systems, is designed to attract first time users who expect future expansion of their information processing facilities. The Amexon system will initially be based on the IBM Personal Computer which will normally be supplied with expanded memory, hard disk storage facilities and a printer.

The third category in Amexon's range of "Growth Path" solutions is the implementation of 16-bit minicomputer systems for users requiring a fast multi-function, multi-user main processor. The company expects to supply these machines to retailers also wishing to offer similar facilities to their clients on this powerful and versatile range of equipment.

AMEXON'S "GROWTH PATH" APPROACH

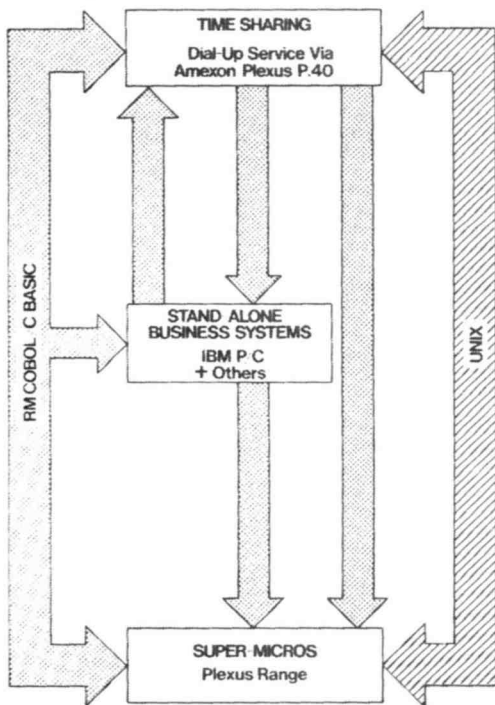

across many business microcomputers and 16-bit machines. The company is confident that the popularity of its flexible approach will lead to the development of a greater range of application packages for programming languages running under UNIX.

The first of Amexon's three-tier "Growth Path" business systems' solutions, involves the supply of computing facilities on a remote access time-shared basis. This will be via telephone lines to the company's PLEXUS P/40-based minicomputer, running under

Amexon Communication and Computer Systems has already identified the systems requirements of a number of business sectors with whom the "Growth Path" approach is likely to prove popular. Negotiations with several leading software houses are already underway which will greatly increase the range of integrated software modules which Amexon already offers to a wide variety of businesses. *Amexon Communication & Computer Systems Ltd., 197 Edgware Road, London, W2 1EZ.*

IT'S AS EASY AS A,B,C...

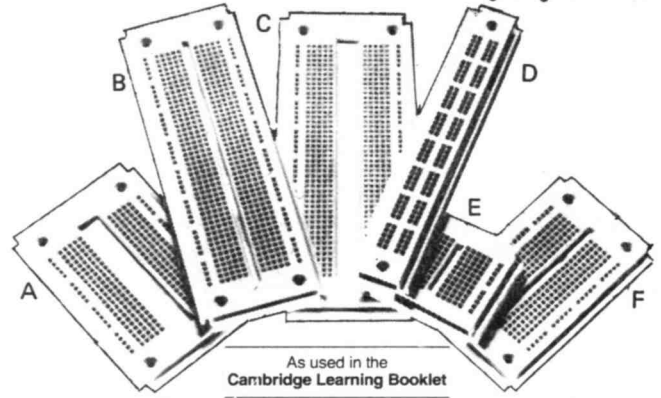

- A EXP 650 For microprocessor chips. £4.25
- B EXP 300 The most widely sold breadboard in the UK; for the serious hobbyist. £6.00
- C EXP 600 .6" centre channel makes this the Microprocessor Breadboard. £7.25
- D EXP 4B An extra 4 bus-bars in one unit. £2.50
- E EXP 325 Built in bus-bars accepts 8, 14, 16 and up to 22 pin ICS. £2.00
- F EXP 350 270 contact points, ideal for working with up to 3 x 14 pin DIPS. £3.45
- G PB6 Professional breadboard in easily assembled kit form. £11.00 (Not illustrated.)
- H PB 100 Kit form breadboard recommended for students and educational uses. £14.25 (Not illustrated.)

& IT'S AS EASY AS 1,2,3 with THE EXPERIMENTOR SYSTEM

SCRATCHBOARD
-BREADBOARD
-MATCHBOARD

1. EXP 300PC which includes one item. A matchboard pre-drilled PCB - £1.50
2. EXP 302 which includes three items. Three 50-sheet scratchboard workpads - £1.75
3. EXP 303 which includes three items. Two matchboards and an EXP 300 solderless breadboard - £8.00
4. EXP 304 which includes four items. Two matchboards and EXP 300 breadboard and a scratchboard workpad - £9.40

The above prices do not include P&P and 15% VAT

TOMORROW'S TOOLS TODAY

GLOBAL SPECIALTIES CORPORATION G.S.C. (U.K.) Limited, Dept. 35H
Unit 1, Shire Hill Industrial Estate,
Saffron Walden, Essex CB11 3AQ.
Tel: Saffron Walden (0799) 21682.
Telex: 817477.

NAME _____

ADDRESS _____

I enclose cheque/PO for £ _____

or debit my Barclaycard, Access, American Express card

No. _____ Exp. date _____

or Tel. (0799) 21682 with your card number and your order will be in the post immediately.

A EXP 650 £5.75	Qty. Reqd.	B EXP 300 £8.05	Qty. Reqd.
C EXP 600 £9.48	Qty. Reqd.	D EXP 4B £3.73	Qty. Reqd.
E EXP 325 £3.16	Qty. Reqd.	F EXP 350 £4.83	Qty. Reqd.
G PB6 £13.80	Qty. Reqd.	H PB 100 £17.53	Qty. Reqd.

Experimentor System

1 EXP 300 PC £2.58	Qty. Reqd.	2 EXP 302 £2.87	Qty. Reqd.
3 EXP 303 £10.35	Qty. Reqd.	4 EXP 304 £11.96	Qty. Reqd.

Boxed prices include P & P and 15% VAT

FREE catalogue
tick box

Global Specialties Corporation (UK) Limited, Dept. 35H
Unit 1, Shire Hill Industrial Estate, Saffron Walden Essex CB11 3AQ

TYPE 161B DUAL POWER SUPPLY KIT

Branime
LEARNING WITH
YOUR KNOWLEDGE

INCORPORATES A POSITIVE & A NEGATIVE REGULATED SUPPLY

BOTH ARE ISOLATED & ADJUSTABLE 1.3V TO 16V D.C.

Interconnect to give 2.6V to 32V or

-1.3V/0/+1.3V to -16V/0/+16V

Output current 1A at 16V to 0.35A at 1.3V

Ripple is less than 1mV

£25.99

inc. P & P and VAT

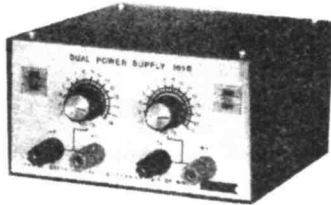

Built & Tested

£37.95 inc. P&P and VAT

Comprehensive design details with calculations

are included so that the kit is an exercise in power supply design. The kit, which uses quality components, is complete with instructions. Case punched and stove enamelled in attractive blue and grey with a printed front panel to give a professional finish.

Excellent for the beginner, the experienced amateur and as a tutorial for schools and colleges.

SEND CHEQUE OR P.O.

ALLOW 21 DAYS FOR DELIVERY

BRANIME MARKETING LTD DEPT. H
BALTHANE IND. EST., BALLASALLA, ISLE OF MAN

156 for further details

NEW PRODUCTS



Micro-based Keyboards

Now available from Verospeed is the Cherry UB88 executive range of microprocessor-based keyboards, specifically designed for high reliability in professional applications.

Featuring 15mm key spacing and a current consumption of 80mA, the self-contained keyboards measure only 305mm x 140mm, and are available in both flat and sloping versions. Height of the flat version is 30mm and maximum height of the sloping keyboard is 35mm.

The UB88 keyboards are based

on Cherry's M81 gold crosspoint key modules, incorporating two-key rollover, a FIFO buffer and selective automatic repeat.

Operating life is ten million operations per key station, switch travel is 2.5mm, and maximum bounce time is 2ms.

Output can be in 8-bit parallel or serial formats, with termination provided by either a 15 way DIN connector or a 6-pin DIN plug.

*Verospeed,
Stansted Road,
Boyatt Wood,
EASTLEIGH,
Hants. SO5 4ZY.*

Dual Timebase 'Scope

House of Instruments announce the availability of the new CS-2100A from Trio. This high performance 4 Channel, 8 Trace, Dual Time Base Oscilloscope has a sensitivity of 1mV/div over its bandwidth of 100 MHz, with an astonishing 500 microV/div to 70 MHz in the cascade mode. Sweep speeds from 2 nanosec/div make for easy observation of fast signals on the large, graduated inner face CRT, with 16 kV providing a bright, sharp, easy to read display with automatic focus.

Extra reliability has been designed and built into the CS-2100A, including the exclusive use of glass epoxy PCB's and Teflon terminals with high impedance circuitry. A separate IC is used to reduce temperature drift in the head amplifiers to an extremely low level. Severe testing is carried out on all

components and assemblies, including the unique CRT system. The CS-2100A is fully guaranteed for two years including free pick-up, repair and return.

The CS-2100A features: dual sweep with completely independent A and B sweeps, push-button selectable 1M ohm/50 ohm input impedance, delayed sweep intensity control, electronic switching with LED lit push-buttons and panel set up memory, 20 MHz bandwidth limiting control, auto trigger (FIX) mode, intensified delayed sweep, and other facilities.

Extremely small for its performance, the CS-2100A is provided with a carry handle/tilt stand, front panel protective cover and optional accessory bay to give true portability and it costs £1,299 exclusive of VAT.

*Quiswood Limited,
30 Lancaster Road,
ST. ALBANS,
Herts. AL1 4ET.*

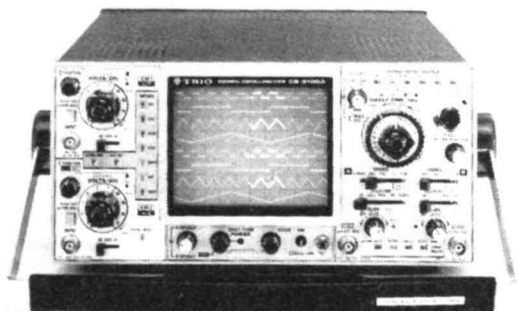

Bigger and Better for 1982
the colourful Wilmslow Audio brochure
— the definitive loudspeaker catalogue!

Everything for the speaker constructor — kits, drive units, components for HiFi and PA.

50 DIY HiFi speaker designs including the exciting new dB Total Concept speaker kits, the Kef Constructor range, Wharfedale Speakercraft, etc.

Flatpack cabinet kits for Kef, Wharfedale and many others.

- ★ Lowest prices — Largest stocks ★
- ★ Expert staff — Sound advice ★
- ★ Choose your DIY HiFi Speakers in the comfort of our ★
two listening lounges
(Customer operated demonstration facilities)
- ★ Ample parking ★

Send £1.50 for catalogue
(cheque, M.O. or stamps — or phone with your credit card number)

- ★ Access — Visa — American Express accepted ★
also HiFi Markets Budget Card.



0625 529599

35/39 Church Street, Wilmslow, Cheshire SK9 1AS



Lightning service on telephoned credit card orders!



157 for further details

Graphics Plotter

Rapid Recall are able to supply a low-cost, high-performance graphics plotter for use with Hewlett Packard personal computers direct from stock. Known as the HP7470A, these will print high-quality multi-coloured diagrams, charts, text and the like, on either paper or overhead transparency film.

There are many applications for the plotter and its computer host. Most common, will be in scientific areas for the graphic presentation of results, in engineering and in the preparation of charts, graphs and pie-charts for sales and management presentation.

The HP7470A is extremely easy to use. Programs resident in any HP Series 80 personal computer (also available from Rapid Recall) guide the operator through the graphic generation sequence by asking simple questions. Once the computer has compiled the diagram or graph, the plotter will print it using up to seven colours. This is the case even though only two coloured pens can be fitted to the plotter at the same time (then the plotter stops and the operator is requested to insert a new 'snap-in' colour pen

when a colour change is required).

Resolution is very high, with the smallest addressable step size only 0.025 mm (0.001 inches). Because of this high-resolution it will plot straight lines and smooth curves that give an artist-drawn appearance. In addition, printing is fast - lines are plotted at speeds of up to 38 cm (15 inches) per second and labels and annotations (in a variety of type styles) at up to six characters per second.

Five internal character sets are included in the HP7470A, including three European sets which eliminates the need to use software generated characters. Each character can be programmed for size, slant and direction. The HP7470A measures only 127 x 432 x 343 mm (5 x 17 x 13.5 inches) and can, therefore, be installed on any desk-top or laboratory bench.

Supplies of paper, transparency film and pens (wide and narrow line for use with paper or transparency film) are also available from Rapid Recall.

*Rapid Recall Limited,
Rapid House,
Denmark Street,
HIGH WYCOMBE
Bucks.*

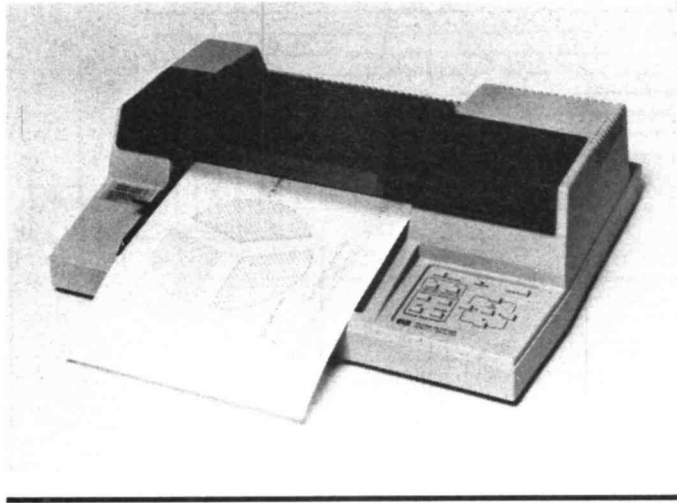

Art Of Supply

These state of the art power supplies from H. Lexton, are brand new technology, which has proven to be stable and reliable without using the old style LM723. Although these Supplies are called 'Lexton', for a quantity of 25 or more other names are possible.

The unit has two 4mm DC output terminals (one red, one black). The black terminal is ground and the red terminal is positive. If a short circuit is applied to the output or the peak current is exceeded the front panel green lamp will go out (this means the unit has tripped). Switch off the

unit and wait for 5 mins. Remove the short and switch the unit back on.

In a "non-short circuit" situation the green lamp will start to dim prior to overload, as a visual warning.

Specs: OUTPUT: 13.8 Volts DC.
REGULATION: Better than 0.15 Volts from no load to full load.
RIPPLE: Better than 30 mV at 100 Hz on full load. INPUT: 220 or 240 Volts AC at 40-60 Hz. Other voltages on request.

*H. Lexton Ltd.,
191 Francis Road,
LEYTON,
London, E10 6NQ.*

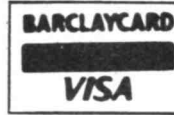

7 HUGHENDEN ROAD, HASTINGS,
SUSSEX. TN34 3TG
Telephone: HASTINGS (0424) 436004

Post & Packing 50p for KS kits, 75p for UK kits, £1.00 for Cabinets. Send 20p S.A.E. for catalogue of our extensive range of kits & Cabinets. Trade, Educational & Export enquiries welcome.

 <p>KS 100 Mini VHF Super-Regenerative Receiver 88-108 MHz 9 V d.c. £4.75 inc V.A.T.</p>	 <p>KS 130 Two Channel Audio Mixer £4.21 inc V.A.T.</p>	 <p>KS 200 Mini FM Transmitter 88-108 MHz 9 V d.c. (not licencable in UK) £7.37 inc V.A.T.</p>
 <p>KS 238 3 Channel Microphone operated sound to light 300 W per channel 240 V a.c. £11.58 inc V.A.T.</p>	 <p>KS 240 3 Chan sound to light, output 3 x 1 kW 240 V £12.63 inc V.A.T.</p>	 <p>KS 160 Dark room timer, timing range 1-99 secs. £11.58 inc V.A.T.</p>
 <p>KS 390 Stereo Pre-Amp, Treb-Bass-Midd loudness & volume control 16.25V D.C. £15.79 inc V.A.T.</p>	 <p>KS 140 L.E.D. Level Indicator, 0.1V R.M.S. to light 1st L.E.D., 1.2V R.M.S. to light all L.E.D. 12-15V D.C. £9.48 inc V.A.T.</p>	 <p>KS 440 Universal anti-theft alarm £10.52 inc V.A.T.</p>
 <p>KS 395 30W Hi-Fi Mono Audio Amplifier £11.58 inc V.A.T.</p>	 <p>KS 230 15 + 15W R.M.S. Stereo Amplifier 24-30V D.C. £16.84 inc V.A.T.</p>	 <p>KS 420 Digital d.c. Voltmeter, 999 mV-999 V .5 V d.c. £17.89 inc V.A.T.</p>
 <p>KS 450 Anti-Theft Alarm for motorcycles. 6-15 V d.c. £9.48 inc V.A.T.</p>	 <p>KS 290 4-way Audio Equalizer £8.42 inc V.A.T.</p>	 <p>KS 300 Westminster Chimes, (Big Ben) £9.48 inc V.A.T.</p>
 <p>KS 490 Nicad Batt Charger, 10-20-45-100-150 mA, 15 V d.c. max. 240 V a.c. £8.42 inc V.A.T.</p>	 <p>UK 108 FM Transmitter Tuneable 88-108 MHz (not licencable in UK) £9.46 inc V.A.T.</p>	 <p>UK 232 Antenna Amplifier for AM/FM £5.27 inc V.A.T.</p>
 <p>UK 502/U MW-LW Radio Receiver £7.37 inc V.A.T.</p>	 <p>UK 875 Capacitive discharge electronic ignition £21.54 inc V.A.T.</p>	 <p>KS 370 2 tone siren, output 10W @ 4 ohm, 6W @ 8 ohm, 100DBM £5.27 inc V.A.T.</p>
 <p>UK 562 Transistor and diode tester £14.73 inc V.A.T.</p>	 <p>UK 558 600MHZ Prescaler £28.42 inc V.A.T.</p>	 <p>UK 11/W Electronic Siren (ready assembled) 12V D.C. £10.52 inc V.A.T.</p>

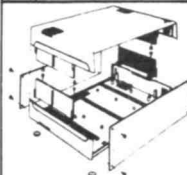

MODEL	OUTSIDE DIMENSIONS				PRICE
	WIDTH		HEIGHT		
	INCH	mm	INCH	mm	
00/3001.00	7.54	191.4	1.81	46	6.89 175 £3.80
00/3001.02	7.54	191.4	2.36	60	6.89 175 £3.80
00/3001.04	7.54	191.4	2.9	74	6.89 175 £4.75

MINIMUM CHIP Z8 SYSTEM

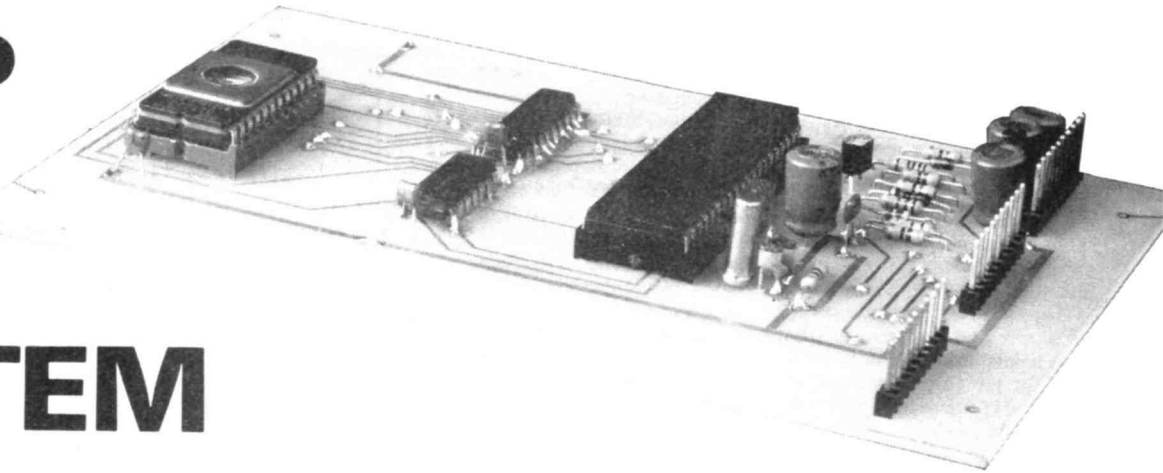

Jonathan Burchell describes a 'stripped down' Z8 system designed to execute programs developed using our Z8 TBDS minimum chip Z8 system.

Readers who can remember as far back as last February will be aware of the original Z8 Tiny BASIC development system. At the time we pointed out the real beauty of the Z8671 Single chip Micro, namely that the device could be used as part of a really minimum chip computer system but, still have 16 lines of parallel lines of I/O, serial I/O etc, and be capable of running up to 4K bytes of BASIC/Machine Code on power-up.

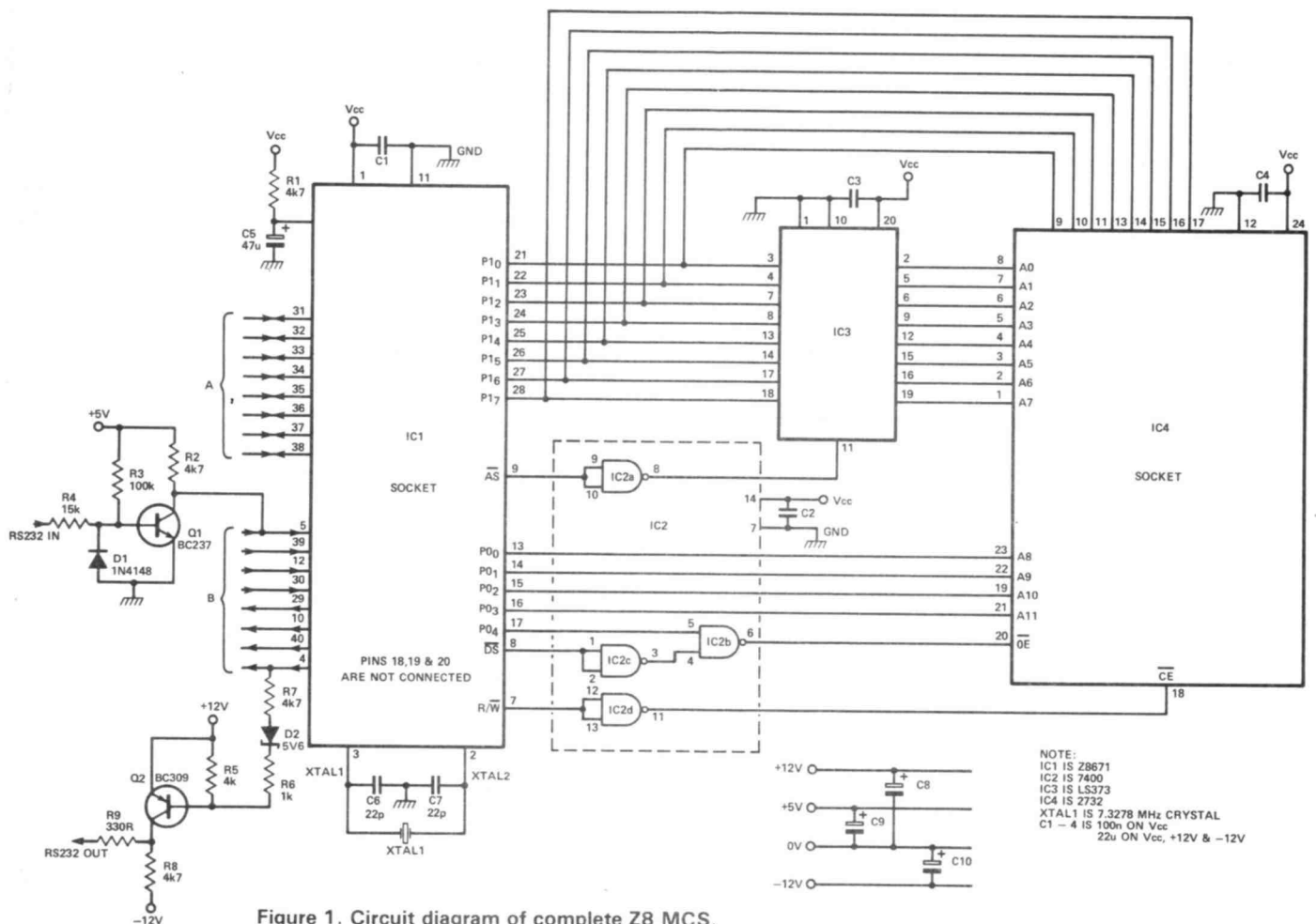

Figure 1. Circuit diagram of complete Z8 MCS.

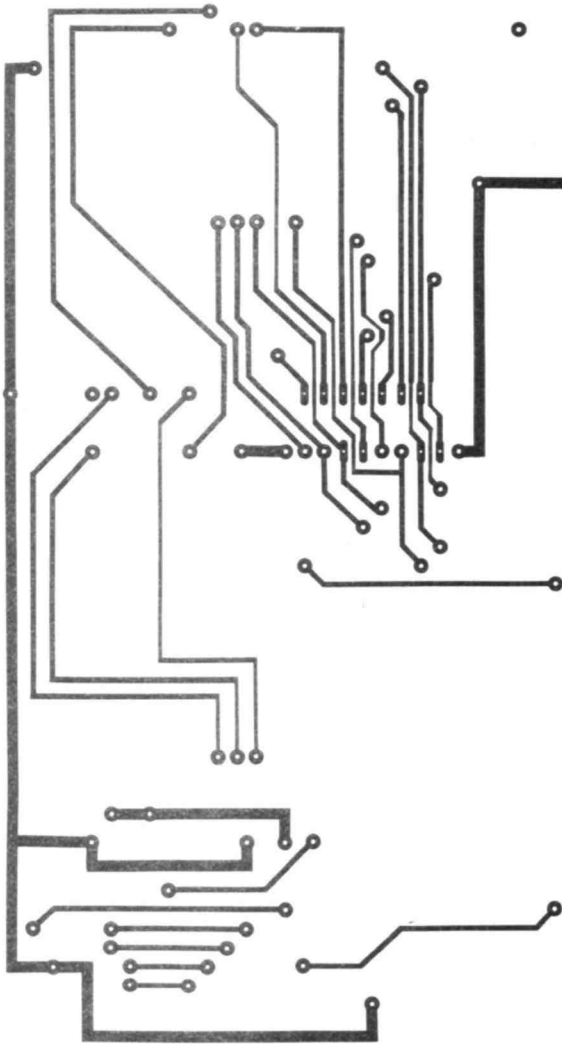

Figure 2. Topside of PCB.

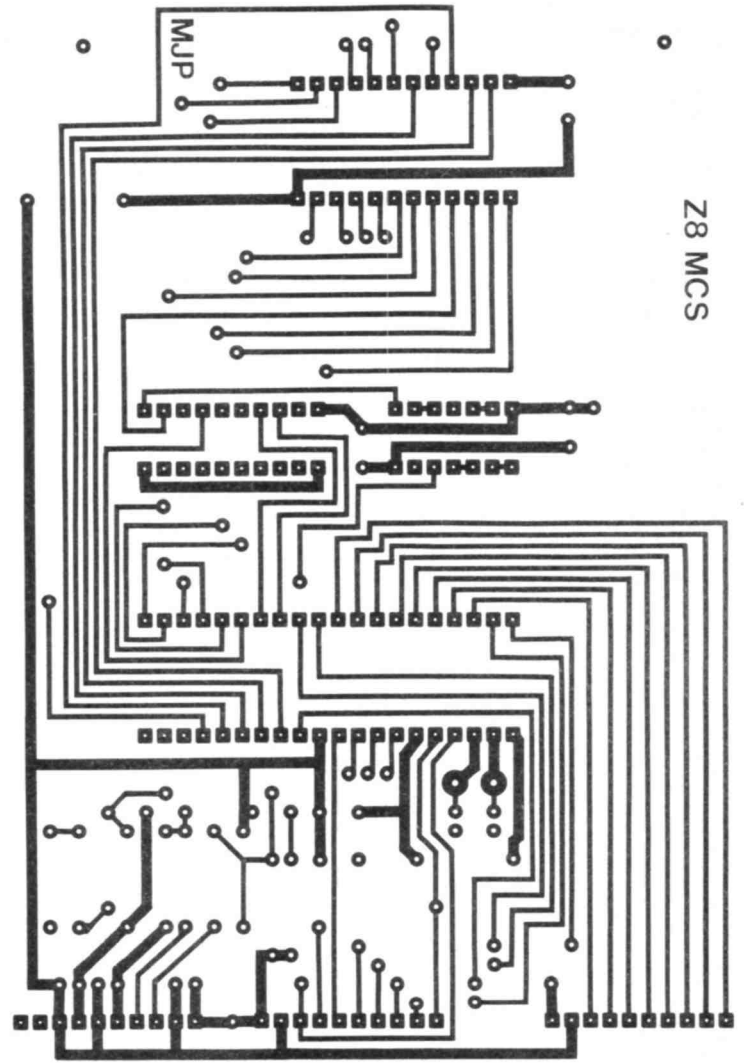

Figure 3. Bottom of PCB.

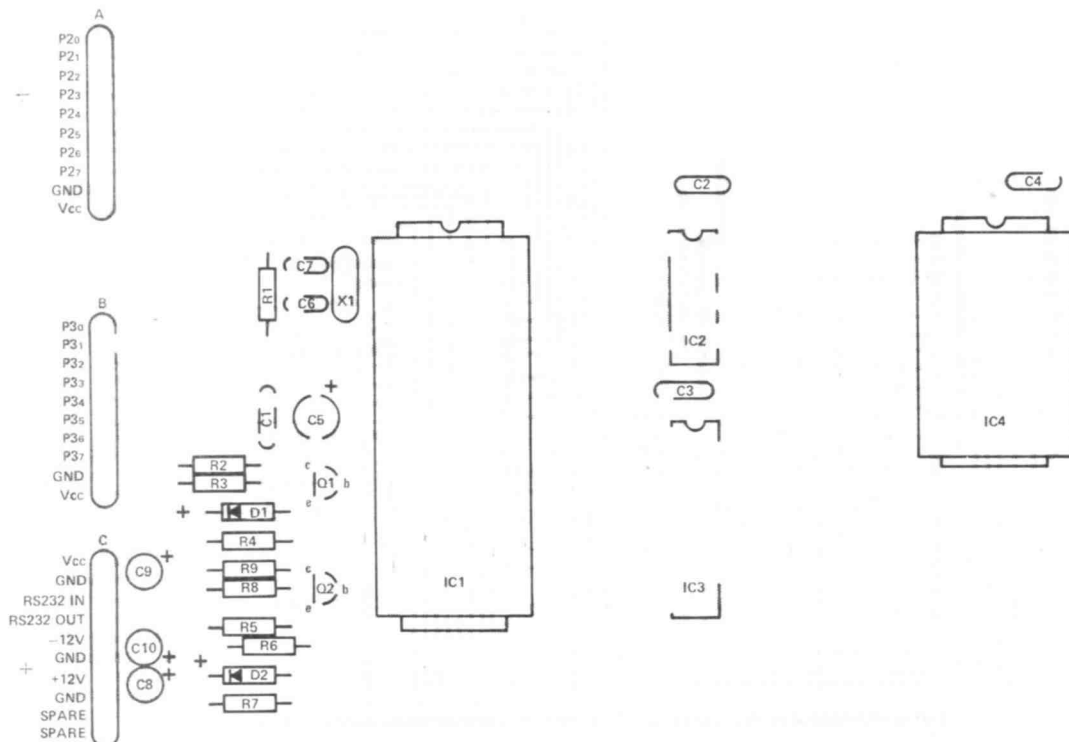

Figure 4. Component overlay.

MINIMUM CHIP Z8 SYSTEM

Circuit Description

IC1 (Z8671) provides the computing and I/O power of the board. R1/C5 provide a straight forward power-on reset circuit, whilst Q1 and Q2 provide serial RS232 capability. If the final application does not require this then they and their associated components may be left off the PCB entirely. IC3 an 8 bit data latch, demultiplexes the address and data busses for the 2732 EPROM, (Plugged into IC4 socket). IC2 a 74LS00 provides an inverter for the data latch and the EPROM enabling circuitry. The EPROM is Selected on every CPU READ cycle, if the address of the read cycle is 1XXX,3XXX,5XXX HEX etc. then the output buffers of the EPROM will be turned on placing data onto the buss. Although this method increases the power consumption of the board by enabling the eprom for every read cycle, it allows slower access eproms to be used (450 ns) than alternative schemes.

The 7.3278 MHz Crystal provides the correct internal clock rate to operate the SERIAL I/O at standard baud rates, however if this facility will not be being used then any crystal upto 8 Mhz may be used instead.

Port 2 of the Z8 is brought out to the set of pins marked A and provides 8 bidirectional I/O lines.

Port 3 is available on the set of pins marked B and provides a mixture of parallel/serial I/O and interrupt/counter timer facility.

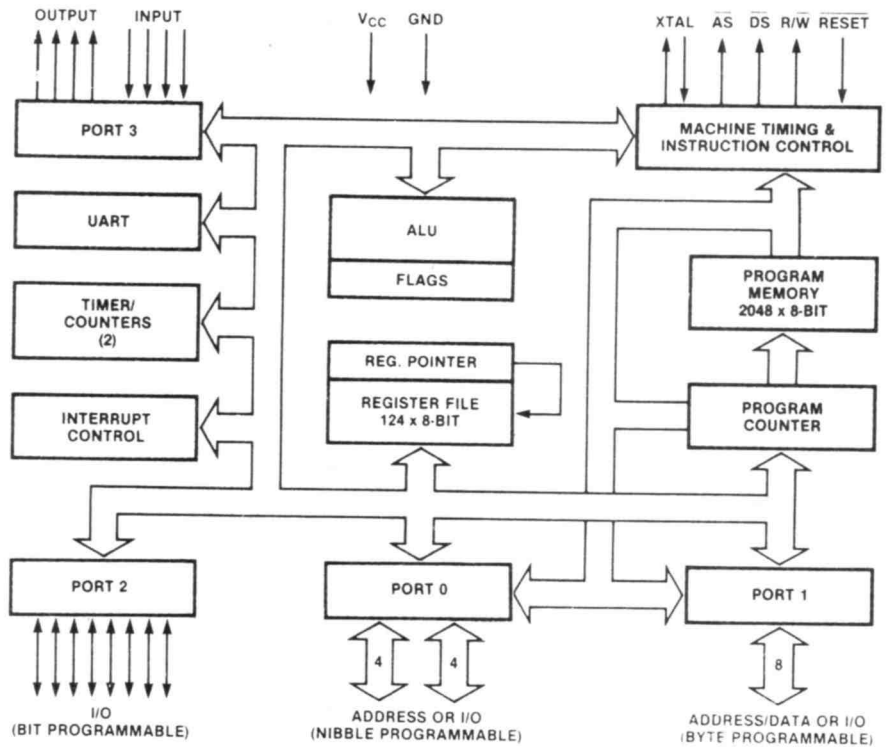

Figure 5. Z8 Internal architecture.

Construction.

The Z8 MCS is constructed on a Double sided PCB using pinning from one side of the copper to the other, rather than PTH in order to keep the cost down.

Figures 2 & 3 detail the top and bottom track layout of the PCB and Fig. 4 shows the component overlay and connector description. The board needs to be supplied with +5 volts, and if the RS232 capability is to be used + and - 12 volts.

ADDRESS (hex) (decimal)		CONTENTS	ADDRESS (hex) (decimal)		CONTENTS
F0-FF	240-255	Z8671 control registers. See map for RAM system.	16-17	22-23	Current line number.
90-EF	128-239	No registers are implemented at these addresses.	14-15	20-21	Second argument in three argument USR subroutine call.
68-7F		The Expression Evaluation stack grows from 7F (hex) down, and the line buffer grows from 68 (hex) up.	12-13	18-19	Last argument and result in USR subroutine call.
40-57	64-103	GOSUB stack; grows down.	10-11	16-17	Basic/Debug uses as scratch. USR subroutine may use, but can not save values here.
40-55	64-05	Area shared by variables M-Z and GOSUB stack. Variables are destroyed if stack grows into this range.	0E-0F	14-15	Pointer to next character to be used in input buffer.
22-55	34-85	Variables A through Z.	0C-0D	12-13	Pointer to the end of the line buffer. R12 defines the page containing the variables, and so contains 00 to indicate the registers.
21	33	Free register, available for USR subroutine.	0A-0B	10-11	Pointer to bottom of GOSUB stack. Initialized to 68 (hex).
20	32	Print column counter, contains current cursor location.	08-09	8-9	Pointer to start of Basic program. This address will be in external ROM, usually 1020 (hex) for auto-start up.
1F	31	Internal variable. Do not modify.	06-07	6-7	Pointer to top of GOSUB stack. Since stack is in registers, 00 will be in R6 and the register number in P7.
1E	30	Basic/Debug uses as scratch. USR subroutine may use, but cannot save values here.	04-05	4-5	Free register. Available for USR subroutines.
1C-1D	28-29	Pointer to constant block.	00-03	0-3	Z8671 I/O ports.
18-1B	24-27	Internal variables. Do not modify.			

Figure 6 Memory map for No-RAM system.

ADDRESS (hex) (decimal)		CONTENTS			
FFFD	65533	Baud Rate. Pattern of lowest three bits sets baud rate. See Appendix B.	100F	4111	Address for IRQ5. When an interrupt occurs at IRQ5, the Z8671 vectors through internal ROM to 100F to get a jump to the address of a user-supplied processing routine.
xxFF		Top of External Memory.	100C	4108	Jump to routine for IRQ4.
xx00		Bottom of highest memory page.	1009	4105	Jump to routine for IRQ3.
1020	4128	First address of Basic/Debug program for auto-start up. Store program starting in byte 20.	1006	4102	Jump to routine for IRQ2.
1015	4117	Address for external output driver. Store a jump to a user-supplied output driver here.	1003	4099	Jump to routine for IRQ1.
1012	4114	Address for external input driver. Store a jump to a user-supplied output driver here.	1000	4096	Jump to routine for IRQ0.
			0800	2048	Bottom of external memory.
			07FF	2047	Top of Z8671's internal ROM.

Figure 7. Interrupt vectors.

Using and programming.

The Z8MCS is designed to be a means of executing the code/program you have developed using the Z8 TBDS. The board provides access to all the Z8 I/O lines. AS a refresher Fig. 5 details the Z8 internal architecture, and thus the facilities available to the programmer. When the device is being used without external memory all variables are held in the register file together with the stack. This means that as subroutines are executed some of the variables will be clobbered, however the variables A-H are normally totally free from this fate and if the program contains only simple expressions and a few subroutines then even A-Z is OK. It's just a case of experimenting and seeing what happens.

Figure 6 shows the memory map for a

system with No-RAM. Nearly all programs developed on the TBDS should run on the MCS without modifications. The only points to remember are that the program must start at %1020 Hex ie 20 hex bytes into the EPROM, and the first line of the program must be a BASIC statement with a line number less than 255. The first 32 (HEX 20) bytes of the EPROM are reserved for interrupt vectors, which may arise as a result of either an external event or an internal. (See the Z8 datapack for full details.) Fig. 7 details these vectors. The only other point to grasp is that because there are no baud rate switches on the Z8MCS the baud rate must be set up by software unless the default speed of 300 baud is required. The following line of code will correctly initialise the UART to a new baud rate.

```
10 44= TABLE :41=3
```

Where TABLE is the required entry from.

Baud Rate	TABLE
19200	1
9600	2
4800	4
2400	8
1200	16
600	32
300	64
150	128
110	175

■ R&EW

YOUR REACTIONS	Circle No.
Good	67
Average	68
Poor	69



'LOOK RUDOLPH — IT'S JUST WHAT I WANTED, A YEARS SUBSCRIPTION TO RADIO AND ELECTRONICS WORLD!



"... AND NIGEL LOVES THE PRESENT FANNY, IN FACT, HE'S OUTSIDE PLAYING WITH IT NOW....."

Testing... Testing... Testing...

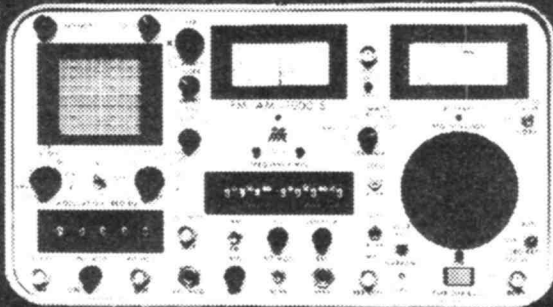

anywhere!

FM/AM 1000s with Spectrum Analyser — we call it the SUPER — S

A portable communications service monitor from IFR, light enough to carry anywhere and good enough for most two-way radio system tests. The FM/AM 1000s can do the work of a spectrum analyser, oscilloscope, tone generator, deviation meter, modulation meter, signal generator, wattmeter, voltmeter, frequency error meter — and up to five service engineers who could be doing something else!

A PRACTICAL TOP UP! MM-100 MULTI-METER

Simply replaces the protective lid of the FM/AM 1000s. It includes a modified probe, PB-114, and a built in speaker unit with independent volume control for audible response to signal measurement. This practical 'top up' will perform the following functions.

Sinad: Measurements for 1 kHz tone (± 20 Hz)

Distortion: To 30%

DC Volts: Up to 300 volts and up to 800 volts when the X10 probe is used

AC Volts: 600 VRMS maximum for frequencies between 25 Hz and 25 kHz

Ohms: Using the modified probe, part number PB-114, Ohms can be measured on scales X1 to X10 K

% AM Measured on the RF signal applied to the FM/AM-1000 unit

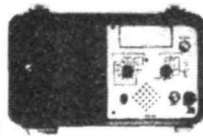

OPTIONAL ACCESSORIES

A choice of R.F. power attenuators and protective carrying cases.

For further information contact Mike Taylor



**Fieldtech
Heathrow**

Fieldtech
Heathrow Ltd.
Huntavia House
420 Bath Road
West Drayton
Middlesex UB7 0LL
Tel 01-897 6446
Telex 23734
FLDTEC G

IFR precision simulators

159 for further details

GAREX (G3ZV1) SX200-N

THE SUPREME
SCANNER

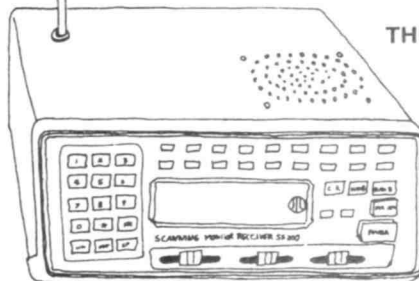

COMPARE THESE FEATURES

- * SPECIALLY DESIGNED FOR EUROPEAN MARKET
- * MICROPROCESSOR CONTROLLED 32,000 CHANNELS
- * AM & FM ALL BANDS
- * WIDER COVERAGE: 26-58, 58-88, 108-180, 380-514MHz; includes 10m, 4m, 2m & 70cm Amateur bands.
- * 5kHz & 12½kHz FREQUENCY INCREMENTS
- * 16 MEMORY CHANNELS WITH DIRECT ACCESS
- * 2 SPEED SCAN/SCAN DELAY CONTROL
- * 2 SPEED SEARCH UP AND DOWN
- * SEARCH BETWEEN PRESET LIMITS UP AND DOWN
- * 3 SQUELCH MODES inc. CARRIER & AUDIO
- * RELAY OUTPUT FOR Aux. CONTROL
- * INTERNAL SPEAKER
- * EXTERNAL SPEAKER & TAPE OUTPUTS
- * LARGE GREEN DIGITRON DISPLAY BRIGHT/DIM
- * AM-PM CLOCK DISPLAY
- * 12V DC, 230V AC OPERATION
- * 12 MONTH WARRANTY FACTORY-BACKED SPARES & 'KNOW-HOW' AND THE ALL-IMPORTANT PRE-DELIVERY CHECK BY GAREX THE

MAIN SERVICE & SALES AGENTS £264.50 inc VAT Delivered

NEW

* REVCONE *

NEW

A new top quality 16-element, all British made, VHF/UHF broadband fixed station aerial from Revco. Ideally suited to SX200 and other VHF/UHF Receivers.

PRICE £24.95 inc

SR-9 monitor: 2m FM with 144-146MHz full coverage VFO + 11 xtal controlled channels; ideal for fixed, /M, /P use. 12V DC operation £47.50
Marine Band SR-9, 156-162MHz, same spec. and price.

CRYSTALS FOR NR-56, SR-9, SR-11, HF-12, TM-56B All 2m channels from £145.00 to 33 (145.825). Also 144.80, 144.825, 144.85 Raynet at £2.46 (+20p post per order). Over 40 popular marine channels at £2.85 (+20p post).

RESISTOR KITS a top-selling line for many years. E12 series, 5% carbon film, 10Ω to 1M, 61 values, general purpose rating ¼W or ½W (state which)

Starter pack 5 each value (305 pieces)	£ 3.10
Standard pack 10 each value (610 pieces)	£ 5.55
Mixed pack, 5 each ¼W + ½W (610 pieces)	£ 5.55
Giant pack, 25 each value (1525 pieces)	£13.60

NICAD RECHARGEABLES physically as dry cell: AA(U7) £1.30; C(U11) £3.35; PP3 £5.55. Any 5+; less 10%, any 10+; less 20%.

CRYSTAL FILTER 10.7MHz, 12½kHz spacing, ITT 901C £6.90
10.7MHz, 25kHz spacing, type 914B or 909B £6.90

HT TRANSFORMER multi-tap mains pri.; 5 secs: 35V 200mA, 115V 150mA, 50V 500mA, 150V 300mA, 220V 300mA £5.50

PYE RADIOTELEPHONE SPARES (s.a.e. full list) Ex. equip., fully guaranteed. Cambridge AM10

10.7MHz I.F. £3.65 2nd mixer £3 455KHz block filter 12½kHz

£9.40 ditto 25kHz £3 455KHz AM IF £4.95 Audio bd. £1.95

WESTMINSTER W15/W30 AM Rx RF 68-88MHz or 148-174MHz

£6.95 10.7MHz IF (inc. 12½kHz xtal. filter) £8.25 2nd Osc £2.10

455KHz IF £5.65 455KHz block filter (12½kHz) £7.35 Squelch

£1.45 QQ206-40a (quick-heat) RF tested £11.95 Aerial relays £1.50

PYE SPARES ARE OUR SPECIALITY

COMPLETE UNITS ALSO AVAILABLE

GAREX FM DETECTOR and squelch conversion for Pye R/T equipment

Ready assembled, full instructions. Tailor-made, easy-fit design, replaces

existing squelch board, with minimum of modifications. For AM

Cambridge £6.30; for Vanguard AM25B (Valve RX) £6.10; for Transis-

tor Vanguard AM25T £6.95

MAIN DISTRIBUTOR OF REVCO AERIALS & SPECIAL PRODUCTS

(trade enquiries welcome)

PRICES INCLUDE UK P&P and 15% VAT

GAREX ELECTRONICS

7 NORVIC ROAD, MARSWORTH, TRING, HERTS HP23 4LS

Phone 0296 668684. Callers by appointment only.

160 for further details



INSIDE THE IC730

Icom have produced yet another gem, and it's really quite hard to imagine where any substantial advance can be made from here . . .

. . . which isn't to say that you can't go over the top with bells and whistles, as demonstrated by such paraphernalia as seem to embellish "ultimate" rigs, like the FT1. But in terms of good honest-to-goodness signal processing functions for the "average" HF radio amateur, there really isn't a flaw in the IC730.

From the superbly compact and mercifully frill-free styling to the perfectly straightforward operation, the IC730 is one of the most delightful HF transceivers yet to pass through the hands of this reviewer. The IC720A with its general coverage receiver (and transmitter for those naughty folk who know where to remove the links from) is nearly as friendly to use, but ask yourself if you *really* want to spend the extra money.

The transceiver is so self explanatory, that there's really not a lot more to be added by a reviewer's 'user' observations. Only the memory and split frequency VFO operation is not entirely obvious from the panel legends, but that is very quickly mastered.

One visitor to the lab was in contact with a Greek station on 10m literally within seconds of seeing the unit for the first time.

When is a DFM not a DFM?

When it's a Direct Feed Mixer, it seems. In deference to the American passion for trademarks, buzz-lines and general marketing trivia, ICOM have succumbed to using the term to describe the fact that the incoming receiver signal doesn't suffer the attentions of an RF stage. Or at least, that's what the words on page 2 of the manual say.

It seems that ICOM lost their nerve at the last minute, and included a switched RF preamp. In extended periods of operation, it really didn't seem to do much that couldn't be achieved by turning up the

audio level control – but quiet moments on 10m were assisted, and so the RF preamp seems to earn its keep.

Note that ICOM switch it out completely when not in use. A good example this, since they use old-fashioned mechanics to perform the function rather than diodes. We appear to be getting inside the box as usual, so out with the microscopes, and on with the object lesson in VFM Japanese communications engineering . . .

Today's lesson . . .

. . . is taken from *Figure one*, the main signal processing circuit according to ICOM. A bit of a whopper this – so we have been obliged to split it into two for the sake of available space. Interestingly enough, we haven't previously looked deeply inside the workings of an HF transceiver (cries of

shame, and G8/G6 bias) – so we propose to take a long cool look at what makes this exemplary rig tick.

Starting with the receiver input, note the way the transmitter output filter is shared to provide a first pass at keeping unwanted signals at bay (and reducing the noise bandwidth). Which is just as well, since for some reason that isn't entirely clear, the receiver preamp is a wideband device. If anyone knows why this wasn't stuck in after the first array of bandpass filters, maybe they'd be kind enough to let us into the workings of the designer's mind? Our best offering is that this way it is kept ahead of all diode switching, and thus avoids possible compromise from all the weaknesses that multiple array diodes switches may be prone to when faced with the consequences of a 5 element 10m beam on a "good" day.

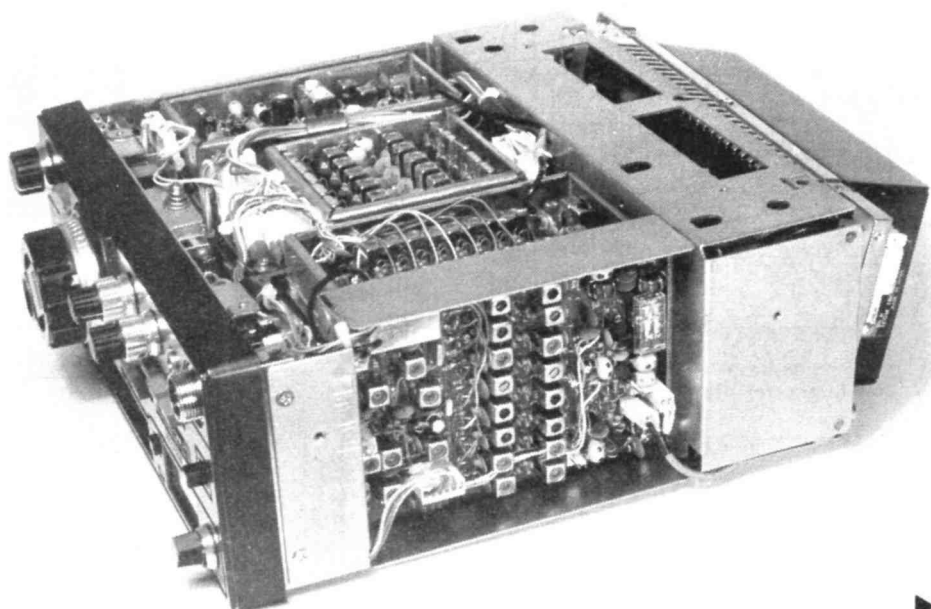

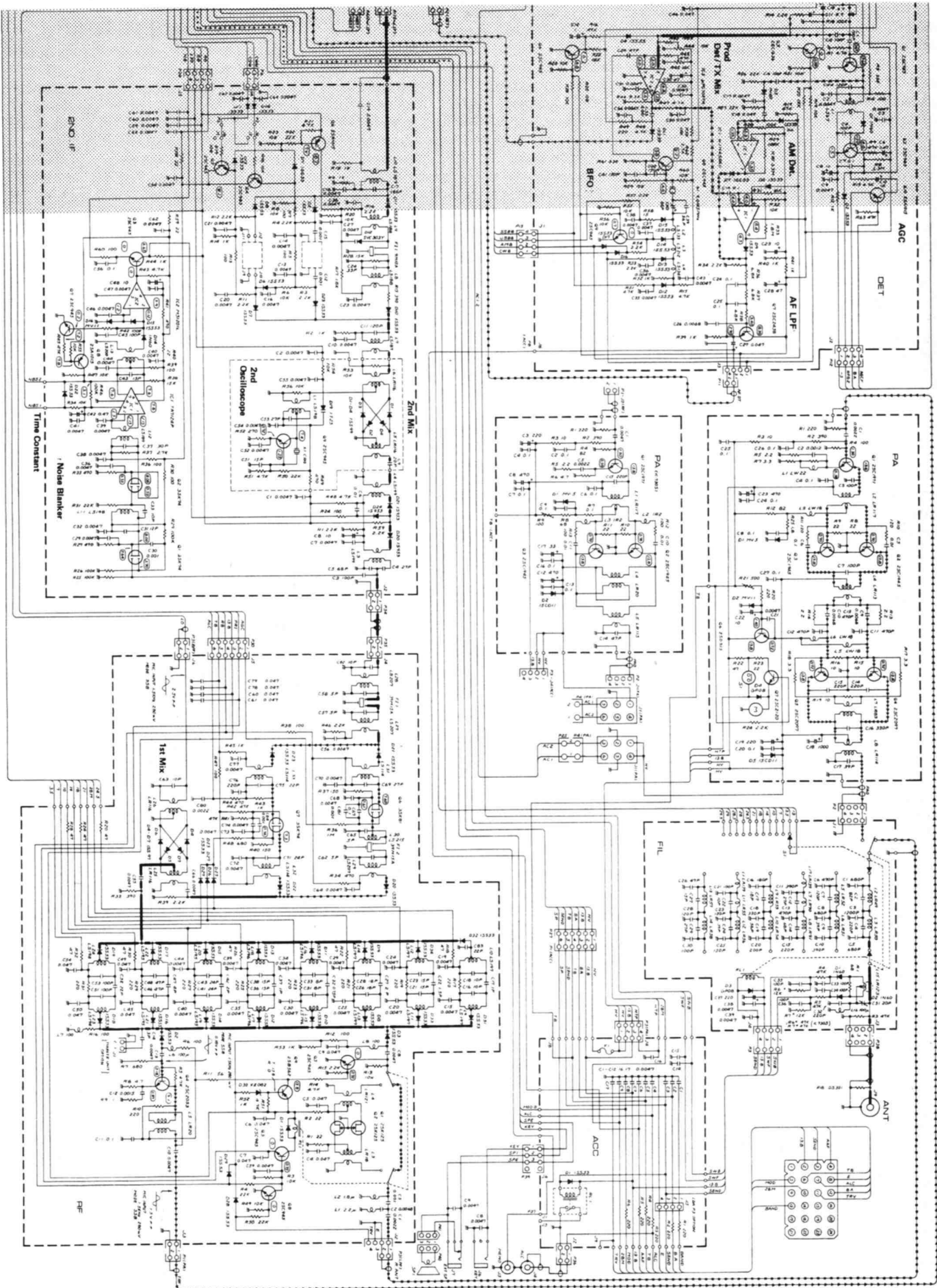

Anyway, the RF preamp is a delightful balanced JFET system, matched to 50 ohms i/o, and probably capable of taking a good deal "up it" before not liking it very much. The 2SK125 (which seems ubiquitous in Oriental HF gear) is a slightly lower spec version of the J310, which most of you will recognise as being a good thing in such places. Investigations are under way to see if this part cannot be procured for rather less than the costly J310. Nevertheless, if you want to emulate the preamp circuit, then J310's will certainly do the job with some to spare.

Note that the receive signal path is shown by the black squares on the circuit diagram (which turn into a solid black line further downstream, where branching of the shared circuitry between RX and TX ceases). The arrowheads designate the transmit path, of which more later. Q's 3,5,8,&9 are part of the TR switching circuitry.

It may assist here to examine the receiver block diagram (Figure two) and see the frequencies involved. The incoming signal is mixed at the first mixer with the synthesised LO (at $F_{rf} + 39\text{MHz}$) to produce a 39MHz first IF signal which is treated to four poles of crystal filter, with some gain (Q6) in between. Purists may note that the output of the first DFM (a

snaazy name for a balanced mixer, remember?) looks into the tuned circuit of L29/C26. Now, Ulrich Rhode ('Ham Radio', October 1975 and elsewhere) has pointed out the importance of terminating double balanced mixers with constant impedances - or you can lose up to 22dB of dynamic range. Rhode's solution was to place Teledyne CP643 JFET in common source between mixer and filter (don't bother looking up the price, it'll frighten you), and thus present an essentially resistive - and thus non-frequency dependant load on the mixer. One up to us, eh?

This may be a pedantic point, but that's the sort of level you get reduced to when trying to pick nits in ICOM circuits, these days. ICOM state that the mixer has a +18dBm intercept, which should do quite nicely for most of us. Most designs only two or three years old are pushing to get 1dBm IPs.

The second IF system mixes down to 9.0115MHz, and you would do well to remember the configuration of the crystal oscillator and DBM, since this circuit is one of the few that the author has used that reliably turns out +7dBm for the mixer using 3rd or 5th overtone crystals. It isn't much favoured in transmitters, since it isn't easily switched.

A Blank Suppression

Before the mixer gets its hands on the signal, a noise blanker gate (D20,21, &24) takes out the impulse noise spikes amplified and detected in the side-chain amplifier formed from Q1,Q2,IC1, IC2 and Q3 in the 2nd IF unit. A very useful feature of this circuit is the way in which the time constant (on pin 3 of IC1 - a TA7124, which is similar in function to an MC1350) is switchable to provide a degree of immunity to the dreaded Russian Woodpecker radar system. Q8 appears to offer a form of clamp circuit to prevent sustained noise bursts from turning the gate off for long periods, since unlike some circuits which are triggered monostables, this one tracks the signal more closely and seems the better for it.

The basic filter supplied with the set is a low cost 10kHz bandwidth 2 pole unit, if we read the type number correctly. Optional multipole SSB and CW filters may be fitted in the dotted outline boxes shown beneath FI1, but you'd be better off waiting to see if you found these really necessary before investing.

D12 (just downstream of FI1) looks rather intriguing. It is in fact a varicap diode with a minimum capacity of 15pF at 9v bias, and maximum of 600pF at 1v-ish

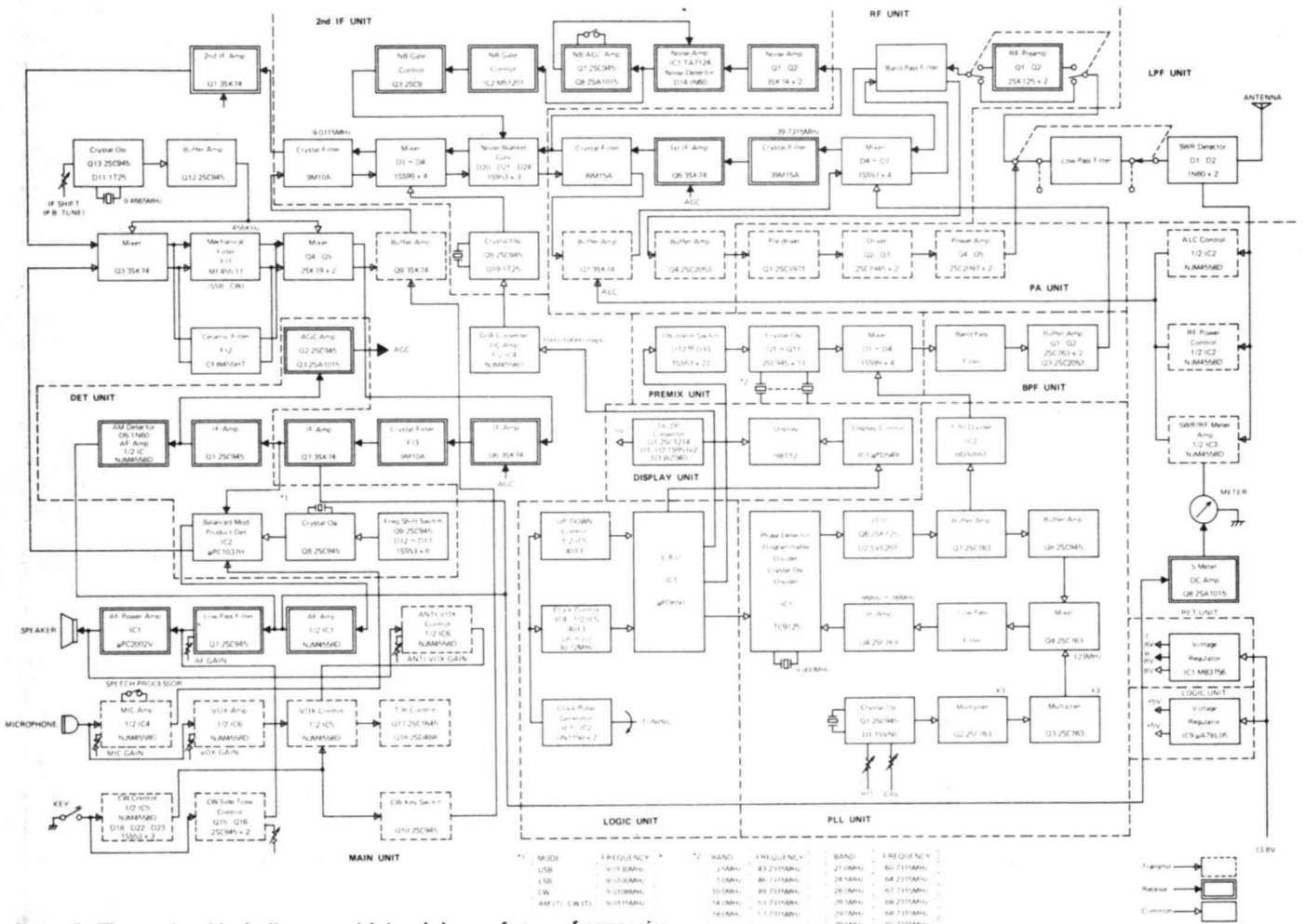

Figure 2: The receiver block diagram, with breakdown of stage frequencies.

(like a TOKO KV1235 series device, we have data on everything at R&EW). Thus when the filter is de-selected, the varicap appears to provide an AC short circuit, presumably there is otherwise some danger of interaction, despite the action of D11.

Incidentally, as all good users of small signal ferrite cored coils should know, it really isn't good practice to pass DC through the tuned winding, and thus possibly affect the magnetic characteristics of the cores. We know *everybody* does it these days, and the DC blocked alternatives are irksome to implement, but we did say this was going to be a pedantic assessment.

Curiouser, and curiouser?

The main unit then provides some 9MHz IF amplification (Q1) and then does a strange thing. It mixes down to 455kHz with 9.4665MHz in Q3 to go through either a low cost 6kHz BW ceramic ladder filter, or mechanical SSB filter - and then it's remixed with the same LO as before, and continues on its way from the balanced mixer of Q4/Q5 at 9.0115MHz again.

Adjustment of the VCXO 9.4665MHz signal provides the IF shift facility, which (if the SSB filter is installed upstream at the first 9MHz IF stage) then provides pass band tuning. But that still doesn't explain the need for all the conversions.

The received signal then goes through two more MOSFET amplifiers, and finds its way to the detector board (RIF) where peak detection in D1 results in the signals for AGC and meter drive. The RF gain control adopts the familiar technique of superimposing itself on the AGC line, thus compensating meter readings. Fast AGC is achieved by switching out Q10 and thus R13/C10.

The product detector IC (IC2: uPC1037H) is fed from the BFO (Q8) with the appropriate amount of "tweak" (L2,L3,L4) selected in the tail end of the crystal circuit to suit the offset of the mode in question. AM signals are detected at D5 and fed through IC1, thence to the common low pass active filter formed on Q7. The audio stage is a TDA2002, and as good R&EW readers, you've seen one before.

The Transmit Process

Starting with the mic socket, note the use of decoupling to prevent the passage of RF in the modulator. A simple, basic precaution, and yet one that still causes more than its fair share of problems for the unwary. Follow the arrowhead into the Main Unit, and after a small detour round the mic gain control, IC4 takes a hold of the signal, amplifies it and sends it off to the DET board, whereupon Q5 impedes further progress if CW has been selected. Assuming it passes on, the next stop is the receiver product detector, here used as a transmit mixer (the thick solid line), when the output (arrowheads again) runs down

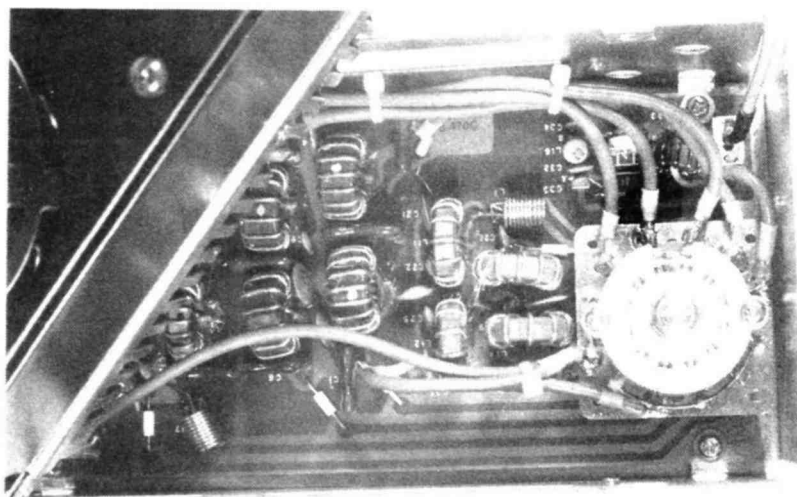

into the Main Unit where the receivers 9MHz/455kHz mixer runs the DSB suppressed carrier signal through the 455kHz filter stage to strip off the unwanted sideband (if SSB is required, the appropriate selection of USB is performed by the BFO "tweak" previously described).

As in the receiver chain, the 455kHz signal is mixed back up to 9MHz again, and arrowheads emerging from D9 (Main Unit) trace the progress of the signal through Q9 onto the 2nd IF. The signal is given the reverse treatment to the receive input path through here, and continues on its way through the RF unit until branched through Q7 for preamplification before being treated to the bandpass filter array.

Q4 (RF Unit) then provides some relatively broadband amplification (at least, the collector is a wideband transformer rather than a tuned device) and sends the transmit signal onto the PA board.

PA time

The circuit illustrates the full blown (literally, a fan comes on during transmit) 100W version, and the "short version", (IC730S), which is restricted to around 10W by the omission of the final stage.

Although levels are not specified in the handbook circuits, it seems that the input to the PA is likely to be around 10mW, progressing 10dB blocks to get to the 100W output of this unit.

Strenuous efforts are used to keep out the LF nasties and other parasitics (the Zobell-like decoupling and feedback R/C combinations to provide a flat response over the range of the system). The first transistor in the amplifier (Q1 - 2SC1971) is a 12W 500MHz ft device, that feeds a pair of 2C1945's (20W/150MHz) in push-pull. Bias for this stage is diode derived (D1), although due deference is paid to the final pair of 2SC2097s - 125W/1GHz ft (that's what our data book says, but we are looking into it!) - with a thermally linked transistor (Q6) feeding the bases.

ALC control for setting the maximum RF output, and clamping the output in the event of serious mismatches is applied to

the gates of MOSFETS Q7 (RF Unit) and Q9 (Main Unit). The sense circuit is a current transformer coupling (L15 on the Filter board) that sends information SWF and SWB (Standing Ratio Forward/Backwards) to IC2 on the main unit.

The transmitter output filter (and also the receiver input filter) comprises a series of LPF's constructed on dust iron toroids of about 15-20mm diameter. It is switched by a rotary wafer switch that the reviewer would question as being man enough for the job of switching 100W of SSB - but no problems occurred during our review assessment. A relay that looks similar to an original OUD series devices actually switches the antenna between the TX and RX - and that, as far as the RF is concerned is that.

We don't have space here to go into the mysteries of the synthesiser, although if enough of you plead with our editor, we may cover this side of the equipment in a couple of issue's time.

All's Well

Tucked away in this circuit are enough bright ideas to keep the average plagiarist dabbling for a long time. Parts of it obviously provide food for thought for receiver and transmitter buffs, and it is hoped that the imagination of some readers may be fired to provide some features based on their interpretations of things like the noise blanker, RF preamp, pass band tuning scheme etc.

ICOM have done a thoroughly good overall job, and we really had to scrape around to pick up a couple of points to gripe about - and then these really don't manifest themselves in amateur use anyway.

■ R&EW

YOUR REACTIONS	Circle No.
Good	61
Average	62
Poor	63

Gary Evans with news of a collaborative publishing venture and of some spectrum add-ons.

DESPITE THE general economic situation, magazines specialising in personal computing matters are doing rather well. Both in terms of advertising and circulation levels, many publications in this area are bucking the trend of magazines in general (R&EW is, of course, doing its own bit in this respect).

Recent ABC figures show that, in particular, Personal Computer World has managed a 54% increase in its circulation over the past year. The title now sells some 85,000 copies every month, that's about 30,000 more than one of its main rivals.

With this impressive track record to its name it is particularly pleasing to us here at R&EW that we have managed to enter into some joint publishing ventures with PCW. Plans are still at an early stage, but the cooperation between ourselves and PCW is likely to take the form of simultaneously publishing details of a low-cost modem and a ZX81 RS 232 card. The idea is that PCW will take care of the software side of the project, for that is their forte, while R&EW will deal with the hardware, an area in which we have expertise.

The articles appearing in both magazines will be complete in themselves but the finer points of the hardware and software will be closely examined in R&EW and PCW respectively.

This sort of combined venture is quite unique and we hope that all goes well and that we can continue the exercise well into 1983.

R&EW Computing

R&EW has plans for a computing supplement to be given away with our March issue and we're amassing a number of very attractive features for the issue. Amongst these are a DVM board for our Z8 TBDS and a complete Z8000 course. This is rather a scoop as we've managed to persuade Zilog to allow us to reproduce their "teach yourself" course for this powerful MPU. The course covers the device in considerable depth and includes a series of questions that allows readers to assess their understanding of the text in each section.

In addition the series of articles will be linked to a competition to win a Z8000 development system.

All in all, a lot of material that will be of interest to computer owners with a practical bent. Stay tuned.

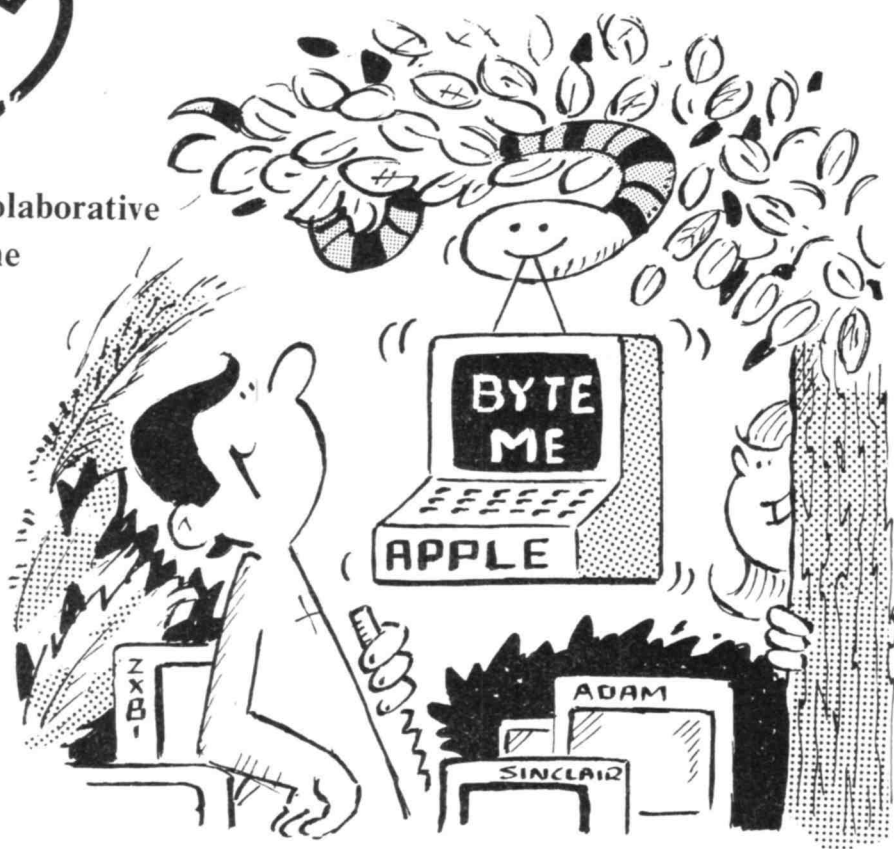

" O.K.. I'LL TRY ANYTHING ONCE... "

Adam and Eve It?

Stephen Adams at 11 Leswin Road, London N16 (01 254 1869) has come up with a number of interesting products that allow Spectrum owners to expand the capabilities of the machine in a number of ways.

The straight adaptor converts the ZX Spectrum to the same expansion port as the ZX81, but does not do any address conversion. It may be used to obtain a full 64K of addresses when the printer is in use. Otherwise you are only left with eight address lines, leaving you only three ports for instance for your own use. This can be used to advantage by transferring some memory mapped devices into the INPUT/OUTPUT map by changing one connection. The device like the rest of the adaptors plugs into the expansion port at the back and does not require any special instructions or machine code to use it.

The "EVE" adaptor is available for people who have bought the 48K ZX Spectrum. Along with another straight-forward modification it will allow the user to access the wide range of ZX81 devices now on the market.

The "EVE" adaptor simply plugs into the back of the ZX Spectrum and the device plugged into the printed circuit board edge. The only devices that will work with the "EVE" adaptor are devices which used to work in the 0-16K section of the ZX81's memory map. The "EVE" adaptor will not

allow you to add more RAM than 48K.

The "Adam" adaptor allows you to expand your 16k ZX Spectrum easily and cheaply to a full 32k, using an existing ZX81 16k RAM pack. The adaptor simply plugs onto your ZX Spectrum allowing you to connect a Sinclair (or compatible) 16k RAM pack doubling your memory - at a stroke.

The ADAM II allows the use of two sets of peripherals at the same time on a ZX Spectrum (16k only). The 16k RAM pack made by Sinclair and others may be used to provide extra memory up to a maximum of 32k. Also any devices which were contained in the 0-16k section of the ZX81's memory map will be transported to appear between 48k-64k on the ZX Spectrum. Such devices as battery backed RAM, ports and EPROM programmers (but no ZX81 EPROM's) should be able to be used on the ZX Spectrum.

All adaptors cost £9 inc vat and postage and packing.

■ R&EW

YOUR REACTIONS	Circle No.
Good	52
Average	53
Poor	54



MORSE TRAINER:MMS2

Gary Evans looks at Microwave Modules' aid to learning morse.

OF THE R&EW editorial staff I am one of the few that don't have a Home Office Transmitting License. This lack of a call sign does mean that I can feel left out of things when the more fervent of our radio amateurs engage in a pie, a pint, and a chat at the local.

In an effort to put this situation to rights I have now determined to amass the necessary brownie points in order that I may become a fully fledged member of the amateur radio fraternity.

As the first step in this grand plan I am attempting to master the morse code. Having determined to learn the code my next step was to cast around for a gadget that would make the task as straightforward as possible.

The Microwave Modules MMS2 looked as if it would fit the bill. The MMS2 is described as an advanced morse trainer and it provides randomly selected morse letters at speeds of 6-32wpm together with a synthesised speech talkback of the code.

Power On

Applying 12V DC to the unit via a rear panel DIN socket, provokes a heavily accented american voice to utter the words 'A to Z' (that's Z pronounced ZEE). This indicates that the MMS2 will select letters from the full alphabet and momentarily pressing the GO/STOP button will produce individual morse groups at a speed of 10 wpm followed by talkback of each letter as it is sent.

To alter the transmission speed range or group length it is necessary to first stop the unit with another depression of the GO/STOP button.

The range button alters the section of the alphabet from which the MMS2 makes its random selections. In common with the other front panel controls it operates by sequentially stepping through the various options available.

Pressing range once, from the initial A-Z range, will restrict the code generated to the letters A-F. Further depressions of range will extend the selection first to A-M, then A-V and finally back to the original A-Z. As each new range is selected, the unit will respond with an appropriate talk back.

The letters/figures switch is used in conjunction with the range selector and when first switched to the figures position will produce code corresponding to the digits 0-9. Operating the range button from this mode will increase the range of the MMS2 to its full range ie all the alphabet plus numerals 0-9.

The speed select button operates in a similar manner to the range control and pressing it will cause the 10 wpm transmission speed of the trainer to be increased to 12 wpm. Further depressions will cause the unit to cycle through the low range of speeds, first to 14 wpm then 6 and 8 before returning to the initial 10 wpm speed.

Moving the speed select switch to high will allow the unit to be cycled through the faster speeds of 16,20,24,28 and 32 wpm.

It is interesting to note that at speeds less than 12 wpm the characters are still sent at 12 wpm but the spacing between them is lengthened to suit the selected speed. This approach is widely accepted as being the best way to learn morse as, from the start of training, it is the "sound" of a particular letter that becomes familiar. This is far better than attempting to learn each letter as a series of dots and dashes. If this approach is adopted, as an attempt to master faster speeds is made the brain can no longer cope with dissecting each code group and then relating it to a letter. This results in a mental block at about the 10 wpm mark, as a new technique for learning is mastered.

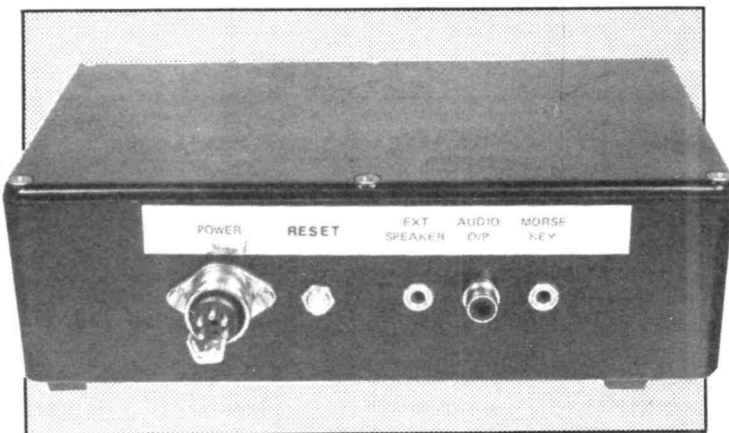

The rear panel of the trainer carries sockets for power supply, external keyer, etc.

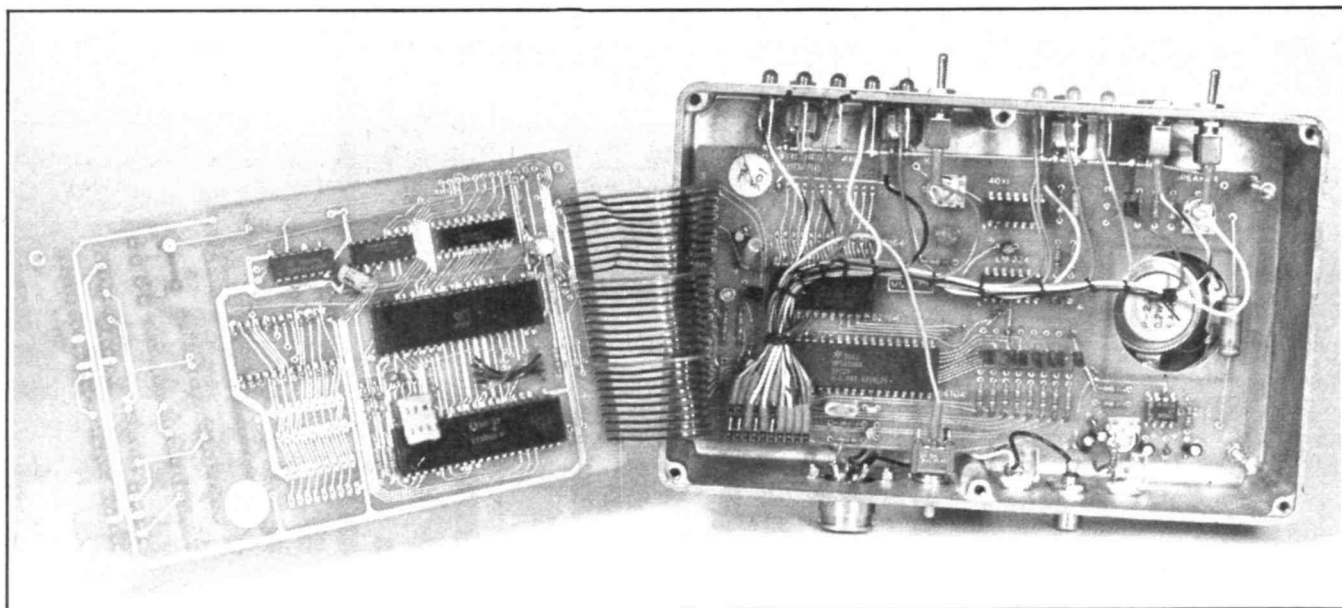

This internal view of the MMS2 reveals two PCBs which carry the two MPUs and associated circuitry.

If from the word go, it is the sound of 12 wpm morse that has been used for training, this mental block problem is obviated as it is the 'sound' of a letter group that will have been learnt, not its individual parts.

The select length button allows for individual letters to be sent, with talkback, or to postpone talkback until either five or fifty characters have been sent. In the fifty character mode, the talkback may be repeated by use of the repeat key.

In addition to the morse and speech generation capabilities of the MMS2 it features an input for a morse keyer. When the trainer is used in this fashion the group length is selected as before and after the group has been sent the MMS2 will res-

pond with either a talkback of the code or an 80Hz tone to indicate non-recognition of the morse.

If the group length selected is either 5 or 50 characters the five 'speed' LED's will indicate the successful entry of each character. A 400 Hz tone is generated when the complete group has been sent. This tone is followed by the talkback and another tone to indicate the trainer is ready for the next block of code.

The talkback of code in this mode is accompanied by a readout of the approximate speed at which the code was sent, with the limitation that speeds above 20 wpm will be given as 20 wpm regardless of the actual sending speed.

Talkback may also be suppressed entirely and the unit will then act as a simple practice oscillator.

The rear panel of the MMS2, as well as providing sockets for DC voltage supply and the keyer input, also provided an audio output suitable for feeding to an external speaker (250 mW available) and a line level output suitable for making a recording of the trainer's output.

Impressions

Operation of the MMS2 was very easy to master, the front panel LEDs giving a clear readout of the exact status of the trainer.

The random selection of characters sent and the ease with which the speed and group length can be altered means that the MMS2 is far more versatile than any tape based learning program. The ability of the device to provide talkback of keyed morse is also a distinct advantage of the trainer.

The trainer is equally suitable for both beginners and the more experienced keyer who wants to brush up his skills or to increase sending speed.

At £169 the MMS2 is possibly of more interest to the well heeled pupil than those of modest means but for a club the unit should prove a very attractive piece of equipment.

It has certainly helped me on the way to the 12 wpm mark and my thanks to Microwave Modules for sparing the unit for this review.

■ R&EW

LETTERS			
A	di-dah	J	di-dah-dah-dah
B	dah-di-di-dit	K	dah-di-dah
C	dah-di-dah-dit	L	di-dah-di-dit
D	dah-di-dit	M	dah-dah
E	dit	N	dah-dit
F	di-di-dah-dit	O	dah-dah-dah
G	dah-dah-dit	P	di-dah-dah-dit
H	di-di-di-dit	Q	dah-dah-di-dah
I	di-dit	R	di-dah-dit
S	di-di-dit	T	dah
U	di-di-dah	V	di-di-di-dah
W	di-dah-dah	X	dah-di-di-dah
Y	dah-di-dah-dah	Z	dah-dah-di-dit

NUMBERS			
1	di-dah-dah-dah-dah	6	dah-di-di-di-dit
2	di-di-dah-dah-dah	7	dah-dah-di-di-dit
3	di-di-di-dah-dah	8	dah-dah-dah-di-dit
4	di-di-di-di-dah	9	dah-dah-dah-dah-dit
5	di-di-di-di-dit	0	dah-dah-dah-dah-dah

PUNCTUATION MARKS AND SPECIAL CHARACTERS			
Period (.)	di-dah-di-dah-di-dah	Wait (AS)	di-dah-di-di-dit
Comma (,)	dah-dah-di-di-dah-dah	Pause (BT)	dah-di-di-di-dah
Question Mark (?)	di-di-dah-dah-di-dit	Invitation to Transmit (K)	dah-di-dah
Fraction Bar (/)	dah-di-di-dah-dit	End of Message (AR)	di-dah-di-dah-dit
Error in Transmission	di-di-di-di-dit	End of Work (VA)	di-di-di-dah-di-dah

This is what its all about, the morse code. Learning the code from a table like this however is not the best way of tackling the task as its likely to cause problems in reaching the 12 wpm target.

YOUR REACTIONS			
	Good	Average	Poor
Circle No.	88	89	90

S.E.M.

UNION MILLS, ISLE OF MAN
Tel: MAROWN (0624) 851277

SENTINEL 2M LINEAR POWER/PRE-AMPLIFIERS.

Now feature either POWER AMP alone or PRE-AMP alone or both POWER AND PRE-AMP or STRAIGHT THRU when OFF. Plus a pre-amp GAIN control from 0 to 20dB. N.F. around 1dB with a neutralised strip line DUAL GATE MOSFET.

Ultra LINEAR for all modes and R.F. or P.T.T. switched. 13.8V nominal supply. SO239 sockets.

Three Models:

1. **SENTINEL 36** Twelve times power gain. 3W IN 35W OUT. 4 amps. Max. drive 5W. 6" x 2 1/2" front panel, 4 1/2" deep. **£62.50 Ex stock.**
2. **SENTINEL 50** Five times power gain. 10W IN 50W OUT. Max. drive 16W 6 amps. Same size as the Sentinel 35. **£74.50 Ex stock.**
3. **SENTINEL 100** Ten times power gain. 10W IN 100W OUT. Max. drive 16W. Size: 6 1/2" x 4" front panel, 3 1/2" deep. 12 amps. **£100 Ex stock.**

All available less pre-amp for **£8.00** less.

POWER SUPPLIES for our linears 6 amp **£34**, 12 amp **£49**.

SENTINEL AUTO 2 METRE or 4 METRE PRE-AMPLIFIER

Around 1dB N.F. and 20dB gain, (gain control adjusts down to unity). 400W P.E.P. through power rating. Use on any mode. 12V 25mA. Sizes: 1 1/2" x 2 1/2" x 4". **£28.00* Ex stock.**

PA5 Same specification as the Auto including 240V P.S.U. **£33.00*.**

SENTINEL STANDARD PRE-AMPLIFIER. £15 Ex stock.

PA3, 1 cubic inch p.c.b. to fit inside your equipment. **£10 Ex stock.** 70cm versions of these (except PA5) **£4.00 extra. All ex stock.**

S.E.M. TRANZMATCH

The most VERSATILE Ant. Matching system. Will match from 15-5000 Ohms BALANCED or UNBALANCED at up to 1kW. Link coupled balun means no connection to the equipment which can cure TV1 both ways. SO239 and 4mm connectors for co-ax or wire feed. 160-10 metres TRANZMATCH **£69.60 Ex stock.** 80-10 metres **£62.60.** EZITUNE built in for **£19.50 extra.** (See below for details of EZITUNE). All ex stock.

3 WAY ANTENNA SWITCH 1Kw SO239s **£15.00.**

S.E.M. 2 METRE TRANZMATCH. 5 1/2" x 2", 3" deep. SO239s **£24.90 Ex stock.**

S.E.M. EZITUNE

Clean up the bands by tuning up without transmitting. Connects in aerial lead, produces S9 + (1 - 170MHz) noise in receiver. Adjust A.T.U. or aerial for minimum noise. You have now put an exact 50 Ohms into your transceiver. Fully protected, you can transmit through it, save your P.A. and stop QRM. **£25.00* Ex stock.**

S.E.M. AUDIO MULTIFILTER. To improve ANY receiver on ANY mode. The most versatile filter available. Gives "passband" tuning, "variable selectivity" and one or two notches. Switched Hi-pass, Lo-pass, peak or notch. Selectivity from 2.5KHz to 20Hz. Tunable from 2.5KHz to 250Hz. PLUS another notch available in any of the four switch positions which covers 10KHz to 100Hz. 12V supply. Sizes: 6" x 2 1/2" front panel, 3 1/2" deep, all for only **£57.00 Ex stock.**

SENTINEL AUTO H.F. WIDEBAND PRE-AMPLIFIER 2-40MHz, 15dB gain. Straight through when OFF. 9-12V. 2 1/2" x 1 1/2" x 3". 200W through power. **£19.55 Ex stock.**

SENTINEL STANDARD H.F. PRE-AMPLIFIER. No R.F. switching. **£12.62* Ex stock.**

S.E.M. IAMBIC KEYS

The ultimate auto keyer using the CURTIS custom LSICMOS chip. Tune and sidetone Switching. **£34.50 Ex stock.** Twin paddle touch key. **£12.50 Ex stock.**

AN IMPORTANT NEW RECEIVER BREAKTHROUGH

Following our development of an rx for commercial watchkeeping, we are producing this for the amateur. Although this is a very small and economically priced unit, it is NOT a "toy", as the spec below shows. It is ideal as a first receiver for the beginner or an additional one for the shack or pocket.

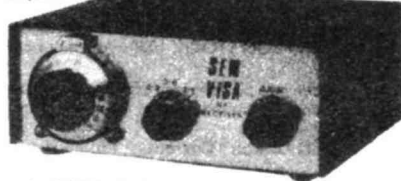

*IF Breakthrough, NONE; *IMAGE, NONE; *Selectivity ±2KHz; *OUTPUT, 1W; *Sensitivity .1 uV; *9-12V, 20mA quiescent; *2 1/2" x 6" x 3"; *OVERLOAD, Wanted sig. 30 uV, UNWANTED, 100 MV. 50KHz away. No degradation; *Case: Ca. plated steel. Black Al. cover; *Freq.: 3.5-3.8MHz (80 metres); *Modes: SSB/CW. Since nothing like this has appeared before, you may be a little sceptical, (especially when you get to the price). So if you are not delighted or amazed with its performance, we will refund your money in full if it is returned within 14 days. **PRICE: £39.00.**

12 MONTHS COMPLETE GUARANTEE INCLUDING ALL TRANSISTORS.

Prices include VAT and delivery. C.W.D. or phone your credit card number for same day service. *Means Belling Lee sockets, add £1.90 for SO239s or BNC sockets. Ring or write for more information. Place orders or request information on our Ansaphone at cheap rate times.

161 for further details

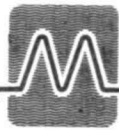

MICROWAVE MODULES LTD

THEY'RE ALL NEW... AND FIRST CLASS!

MM2001

RTTY TO TV CONVERTER



NOW WITH EXTRA FACILITIES!
— SUITABLE FOR UOSAT

This converter, MM2001, contains a terminal unit and a microprocessor controlled TV interface, and requires only an audio input from a receiver and a 12 volt DC supply to enable a live display of "off-air" RTTY and ASCII on any standard domestic UHF TV set.

The MM2001 will decode these speeds:

RTTY : 45.5, 50, 75, 100 baud
ASCII : 110, 300, 600, 1200 baud

A printer output (Centronics compatible) allows hard copy of received signals. This unit is compatible with amateur and commercial transmissions.

MML144/30-LS

144MHz 30 WATT LINEAR & Rx PREAMP



FEATURES

- 30 WATTS OUTPUT POWER
- SUITABLE FOR 1 OR 3 WATT TRANSCEIVERS
- LINEAR ALL MODE OPERATION
- STRAIGHT THROUGH MODE WHEN TURNED OFF
- ULTRA LOW NOISE RECEIVE PREAMP (3SK88)
- EQUIPPED WITH RFVox

This new product has been developed from our highly successful MML144/25. It is suitable for use with 1 watt or 3 watt transceivers and the input level is switch selectable from the front panel. Other front panel mounted switches controlling the switching circuitry allow the unit to be left in circuit at all times. The linear amplifier and the ultra low noise receive preamp can both be independently switched in and out of circuit. In this way maximum versatility is afforded.

USE THIS NEW AMPLIFIER WITH YOUR FT290R, CS8, TR2300 etc. AND HAVE MOBILE OR BASE STATION PERFORMANCE AT A REALISTIC COST!

MML144/100-LS

144MHz 100 WATT LINEAR & Rx PREAMP

(appearance as 30 Watt model)

100 WATTS OUT FOR 1 OR 3 WATTS INPUT ON 144MHz.

FEATURES:

- 100 WATTS RF OUTPUT SUITABLE FOR 1 WATT
- OR 3 WATT TRANSCEIVERS
- STRAIGHT THROUGH MODE WHEN TURNED OFF
- ULTRA LOW NOISE RECEIVE PREAMP (3SK88)
- EQUIPPED WITH RFVox
- SUPPLIED WITH ALL CONNECTORS

This new two stage 144MHz solid state linear amplifier has been introduced as a result of the large number of low power transceivers currently available. When used in conjunction with such transceivers this unit will provide an output of 100 watts.

Several front panel mounted switches controlling the switching circuitry allow the unit to be left in circuit at all times. The linear amplifier and the ultra low noise receive preamp can both be independently switched in and out of circuit. In this way maximum versatility and flexibility is available to the user at the flick of a switch.

USE THIS NEW AMPLIFIER WITH YOUR FT290R, CS8, TR2300 etc. AND HAVE MOBILE OR BASE STATION PERFORMANCE

MTV435

435 MHz TELEVISION TRANSMITTER



FEATURES:

- 20 WATTS PSP OUTPUT POWER
- BUILT IN WAVEFORM TEST GENERATOR
- TWO VIDEO INPUTS
- AERIAL CHANGEOVER FOR RX CONVERTER
- TWO CHANNEL USING PLUG-IN CRYSTALS

This high performance ATV transmitter consists of a two channel exciter, video modulator and a two stage 20 watt linear amplifier. The unit will accept both colour and monochrome signals, and a sync pulse clamp is incorporated to ensure maximum output. An internal pin diode aerial c/o switch allows connection of the aerial to a suitable receive converter when in the receive mode. (MMC435/600 - £27.90). Full transmit/receive switching is included together with an internal waveform test generator which will assist the user in adjusting the gain and black level controls.

£189 inc. VAT (P&P £2.50) £69.95 inc. VAT (P&P £2.50) £159.95 inc. VAT (P&P £3) £149 inc. VAT (P&P £3)

ALL MICROWAVE MODULES PRODUCTS ARE FULLY GUARANTEED FOR 12 MONTHS (Including PA Transistors)

SPACE PERMITS ONLY A BRIEF DESCRIPTION OF THESE NEW PRODUCTS. HOWEVER A FULL DATA SHEET IS AVAILABLE FREE ON REQUEST. OTHER NEW PRODUCTS INCLUDE:

MMS2	— ADVANCED MORSE TRAINER	— £169.00 inc VAT (p&p £2.50)
MML28/100-S	— 10 METRE 100 WATT LINEAR/RX PREAMP	— £129.95 inc VAT (P&P £3.00)
MMK1691/137-5	— 1691 MHz WEATHER SATELLITE CONVERTER	— £129.95 inc VAT (P&P £2.50)

OUR ENTIRE RANGE OF PRODUCTS WILL BE EXHIBITED AND ON SALE AT MOST OF THE 1982 MOBILE RALLIES BY OUR SALES TEAM



WELCOME

MICROWAVE MODULES
BROOKFIELD DRIVE, AINTREE, LIVERPOOL, L9 7AN, ENGLAND
Telephone: 051-523 4011 Telex 628608 MICRO G
CALLERS ARE WELCOME. PLEASE TELEPHONE FIRST.

HOURS:
MONDAY - FRIDAY
9 - 12.30; 1 - 5.00

162 for further details

What to Look For in February's *R&EW*

LOW COST MODEM

With *R&EW*'s low cost modem, £30 will get you an originate-only, 300 baud modem that will allow any computer with an RS232 capability to go nationwide courtesy of Buzby.

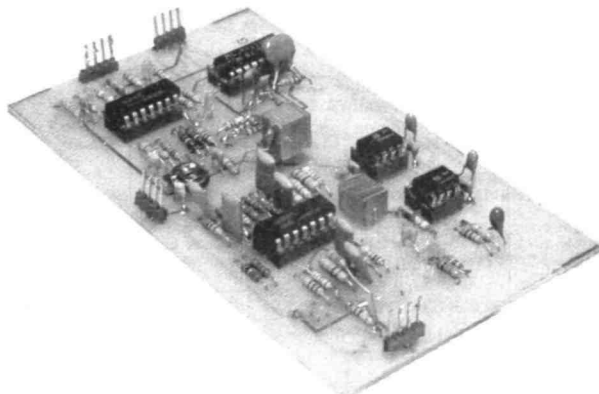

THE COMPLETE ELECTRONICS MAGAZINE

HF Receiver Design

The first of a series of articles looking at the design and specifications of modern receivers.

RS232 Card for the ZX81

A design that enables a ZX81 to both transmit and receive ASCII coded RS232 data. The single-sided PCB plugs into the ZX81's expansion port, and if used in conjunction with our modem, will allow a low cost REWTEL/PRETEL terminal to be implemented.

AUDIO SIGNAL GENERATOR

A high quality design with a frequency range from 10Hz to 100kHz with output level variable between 1V and 1mV. Distortion is only 0.0018% at 1kHz with a frequency stability of 1 part in 1500.

All in all a professional piece of test gear – just the project to tackle during a long winter's night.



BOOK SUPPLEMENT

Wondering what to do with all those book tokens granny gave you this Christmas? Next month's magazine will provide the answers. Our sixteen page supplement will list a wide range of titles covering every area of electronics.

Reserve your copy of February's *R&EW* at your newsagents NOW

FREE GIFT



R&EW Data Brief

NE5553

NE5553 — Dual Tracking Regulator.

This circuit gives you a dual polarity tracking power supply, ideal for use with op-amps, especially in preamp applications. The control voltage potentiometer sets the voltage of the -ve output with respect to ground and the balance control sets the voltage of the +ve supply with respect to the negative supply. To set up the voltages first use the balance control to set ratio of the +ve to -ve voltages. The control potentiometer then adjusts the both with respect to ground. The output range is 5 to 24 volts continuously adjustable, balanced or unbalanced. The regulator chip features thermal overload protection, current limiting and a short circuit current of 400mA.

The maximum AC input from a suitable transformer should be $\pm 32V$. By using the feedback network to carry the high current component through the power transistors the DIL package remains thermally stable even when large currents are supplied. By using an IC mounted heatsink the thermal stability of the chip can be improved.

The current capability of the board will depend largely on the VA of the transformer chosen to supply the AC input. It is not surprising to note that if too much is asked of the circuit in terms of output current, the balance of the tracking control will be upset, but this circuit should easily cope with most preamp power requirements.

PARTS LIST

Resistors	
R1,2	2R7
Potentiometers	
RV1,2	100k Preset
Capacitors	
C1,2	4700uF 35V electrolytic
C3,4,5,6	0.1uF 50V electrolytic
Semiconductors	
Q1	MJ2955
Q2	2N3055
IC1	NE5553
Miscellaneous	
D1	PW02 Bridge Rectifier
IC heatsink, PCB, terminal pins - 6 off, 14 pin DIL socket.	

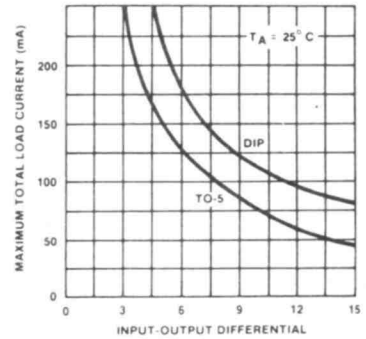
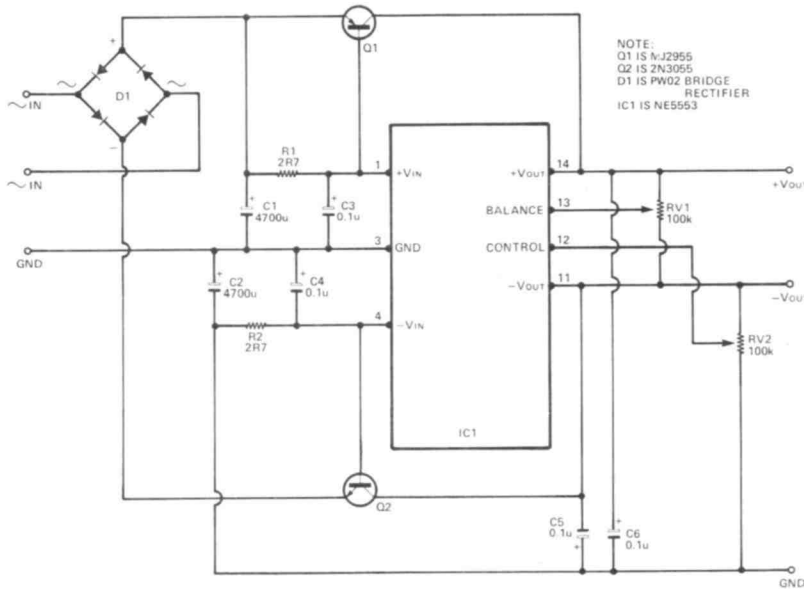

MAXIMUM CURRENT CAPABILITY

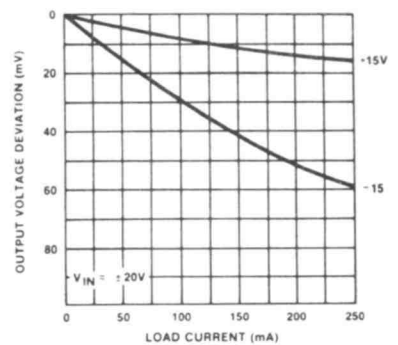

LOAD REGULATION

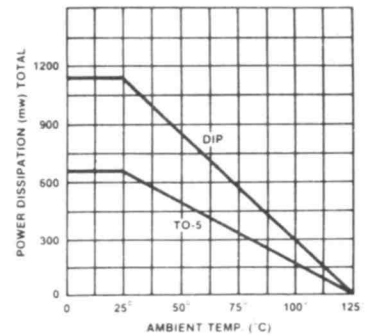

MAXIMUM POWER DISSIPATION

Device capability in free air.

DC ELECTRICAL CHARACTERISTICS

PARAMETER	TEST CONDITIONS	SE5553			NE5553			UNIT
		Min	Typ	Max	Min	Typ	Max	
V _{OUT} Output voltage		+11.5	+12	+12.5	+11.5	+12	+12.5	V
Line regulation	$\pm 20 \leq V_{IN} \leq \pm 30V$		100	150		100	300	mV
Load regulation	$1mA \leq I_{Load} \leq 50mA$ $1mA \leq I_{Load} \leq 200mA$		10	25		10	50	mV
			30	100		30	200	mV
V _{OUT} Output voltage	$1mA \leq I_L \leq 100mA$ $\pm 20V \leq V_{IN} \leq \pm 30V$ over temp. ¹	+11.4	+12	+12.6	+11.4	+12	+12.6	V
		-12.6	-12	-11.4	-12.6	-12	-11.4	V
I _{Q+} Positive quiescent current	I _{Load} = 0		1.70	3.5		1.70	3.5	mA
I _{Q-} Negative quiescent current	I _{Load} = 0		5.60	8.5		5.60	8.5	mA
V _{BAL} Input/output differential voltage			2.5			2.5		V
Output voltage balance			.2			.2		V
Output noise voltage	100Hz to 10kHz		55			55		μV_{rms}
I _{Peak} Peak output current			400			400		mA
Temperature stability of output voltage			1			1		mV/°C

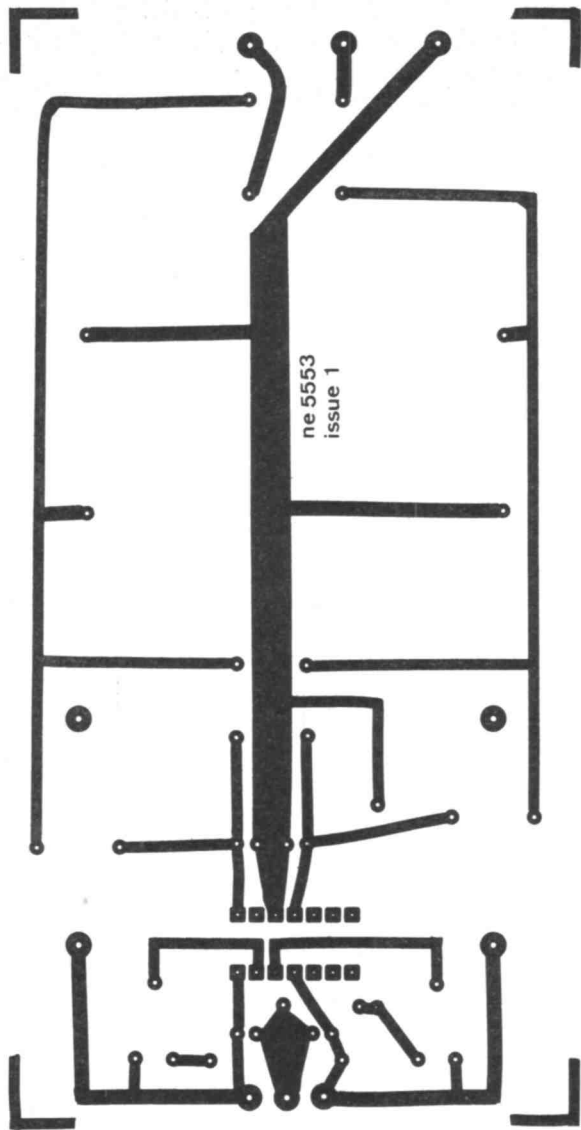

Foil pattern and component overlay for the dual polarity tracking power supply board.

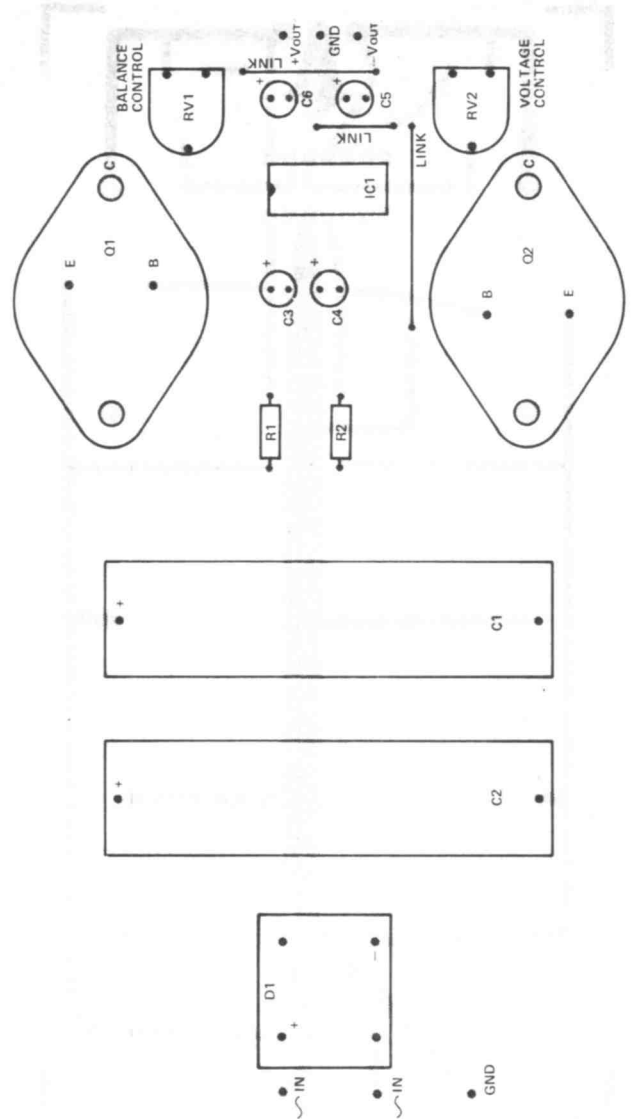

Photograph of the built board.

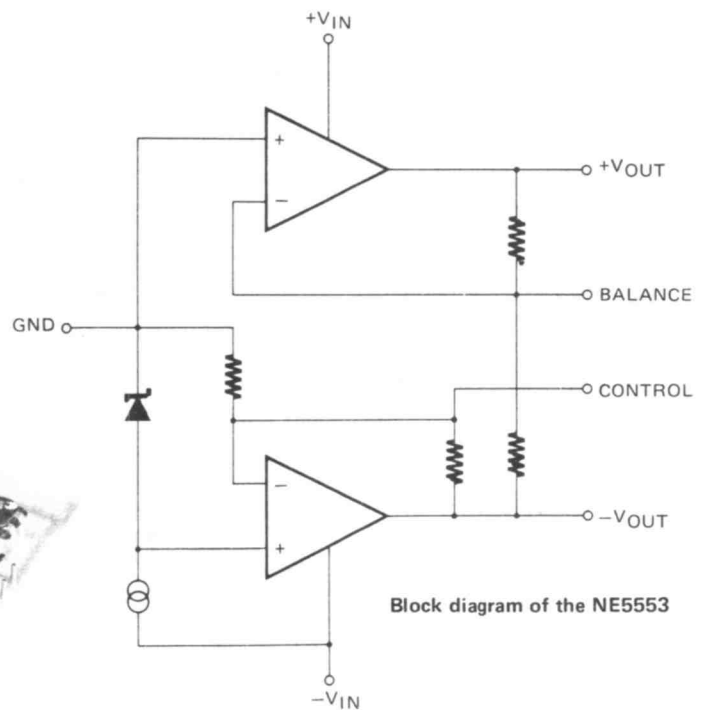
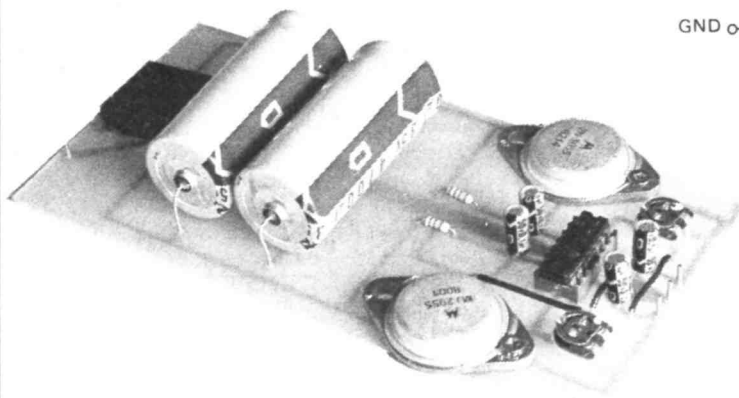

Block diagram of the NE5553

THE

STORY OF

Z

Impedance is one of those black areas in electronics, shrouded in mystery and blamed for any strange effects that designers encounter. N.C. Parkes attempts to unveil some of these mystical phenomena.

QUITE A NUMBER of electronics enthusiasts fail to realise that within DC circuitry – where no phase differences between current and voltage exist – the symbol Z (impedance) is synonymous with R (resistance), in the legendary $V=IR$ formula. This means, even something as mundane as car headlamps have an input impedance (input, rather than output, because they draw current). For example, a typical headlamp bulb of 45 watts, at 12 volts, draws current of 3.75 amps (from $I=W/V$) and the impedance will be $12/3.75$ ohms or $3.2R$ – there are no reactive elements to consider, so the resistance is the same as the impedance.

Now, that might sound a long way from explaining impedance in complex AC circuits, but it need not be. The impedance is still equal to the DC resistance, provided there are no reactive components to take into account. Even when we introduce some components whose impedance is frequency-dependent (eg capacitors have a high impedance at low frequencies, which decreases as the AC frequency rises), Ohms Law can still be applied in terms of the AC current drawn (I_{AC}). So, although this doesn't mean you can just stick a multimeter (set to read ohms) across the input, there are ways to calculate input impedance without sampling the delights of complex algebra and phasor diagrams. One method is discussed next.

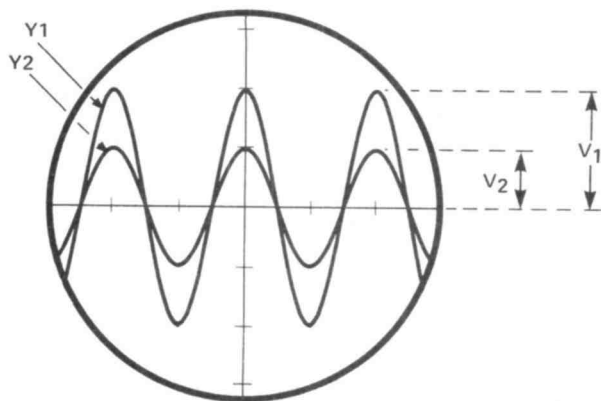

Figure 2: Calculating AC voltage drop from a dual trace. The two waves are lined up so their centre lines coincide, which makes it easy to find the difference between Y1 and Y2 – the peak positive amplitudes.

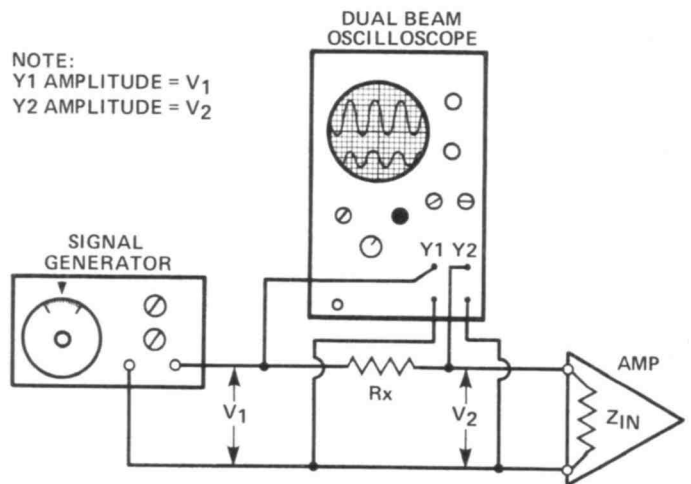

Figure 1: The arrangement for measuring input impedance using a dual beam oscilloscope.

Measuring Up

Having established that we can compute the input impedance of, say, an amplifier, by measuring AC voltage and current, a problem arises. Although it is fairly easy to measure voltage (with an oscilloscope or AC voltmeter), the same is not true of small currents – especially where high impedances are involved. A hi-Z input will draw a minute current (down to picoamps) that is difficult to measure with even the best meters. So, the current drawn has to be calculated by inserting a resistor into the signal line and measuring the voltage dropped across it (you've guessed it, Ohms Law again). The diagram in Fig. 1 shows the set-up for making these measurements with a dual beam 'scope. The voltage dropped across R_x is $V_1 - V_2$ and since $I = V/R$, the AC current through R_x is $(V_1 - V_2)/R_x$. We already know the voltage at the input, V_2 , so replacing R by Z_{IN} (remember, we're dealing with AC) gives $Z_{IN} = V_{AC}$ or by substitution $V_2(V_1 - V_2)/R_x$; simplified to $Z_{IN} = R_x / (V_1/V_2 - 1)$. For example, if $R_x = 10k$ (a high tolerance resistor is essential for accuracy) and the measured values of V_1 and V_2 are 2.8 and 2.4 volts respectively, then $Z_{IN} = 10000 / (2.8/2.4 - 1) = 60000$ or $Z_{IN} = 60k$. Output impedance can also be measured indirectly; but first, we need some conceptual basis to work with.

A common example of output impedance is the internal resistance of DC batteries. This can be envisaged as a small series resistor, which drops some potential when the battery is supplying current. The effect can be seen whenever the battery is heavily loaded – lamps dim and mechanical devices slow down. A similar situation exists for AC over a large part the frequency range. So, one way to calculate the output impedance would be to short circuit the source and measure the current flow. This could be compared with the current supplied under ‘open-circuit’ conditions and the output impedance would be the ratio V_{oc}/I_{sc} . In practice, this method for computing output impedance has serious drawbacks.

Conditions of Transfer

Obtaining the right balance between input and output impedances is quite a tricky business and some kind of compromise is often needed. This doesn't mean ‘impedance matching’ is forgotten, but that it is performed with a single criterion in mind – voltage, current or power (minimising noise figures is a further consideration, but beyond the scope of this article).

One reason for paying particular attention to impedance matching is to gain the best voltage transfer. For this to occur, as much of the source voltage as possible must appear at the input to

Figure 3. Measuring output impedance using a high-impedance voltmeter. The first reading is taken without any loading across the output (open circuit), and the second with a fixed value resistor in position as shown. Make sure both measurements refer to the same frequency.

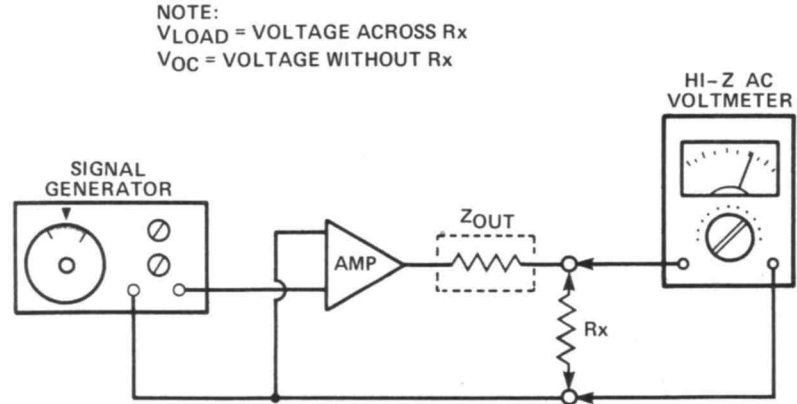

Not only are the measurements likely to be affected by the abnormal operating conditions, but, in some cases, the result of such high current demands could be disastrous. The answer is to employ a shunt resistor across the output and compare open-circuit and ‘loaded’ potentials. The arrangement for taking measurements is shown in Fig. 3 (a high impedance voltmeter is used, but a ‘scope will do). The voltage dropped across Z_{OUT} is given by $V_{OC} - V_{LOAD}$ and the current drawn (loaded) V_{LOAD}/R_x ; therefore the impedance is $Z_{OUT} = R_x (V_{OC} - V_{LOAD})/V_{LOAD}$. Application of this method, and the one for inputs, provides an easy means of measuring impedances. However, the question as to why these quantities are so important still remains. Some examples will provide the explanation.

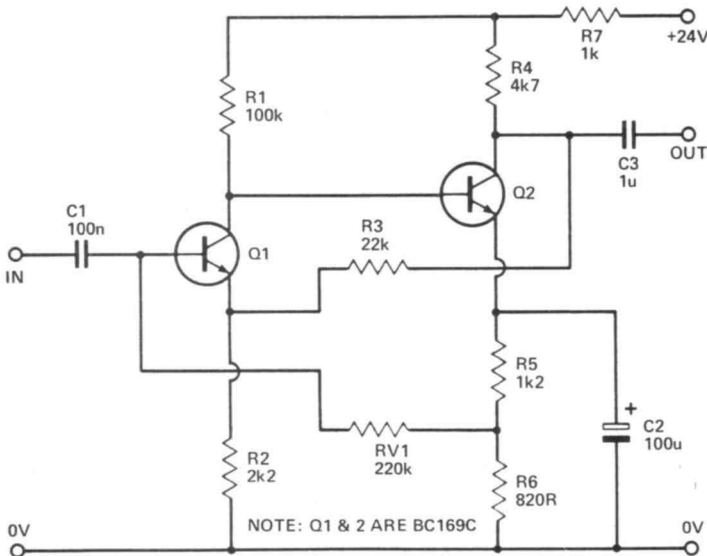
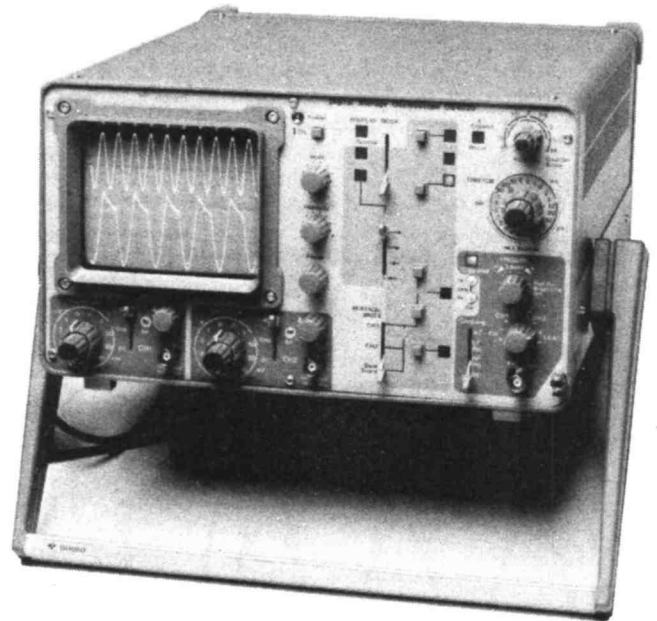

Figure 4: Circuit of feedback amplifier with high input and low output impedances (set R_{V1} for optimum transfer)



A typical dual beam oscilloscope.

the next stage. The available voltage depends on input and output impedances as well as on the original potential. This can be seen from the derived formula $V_{IN} = V_{ORIG} Z_{IN} / (Z_{OUT} + Z_{IN})$, and if Z_{IN} is very large compared to Z_{OUT} , then V_{IN} almost equals V_{ORIG} . As a rule of thumb, the input impedance of any following stage should be at least ten times the output impedance of the preceding one (voltage transfer). Amplifiers best suited for voltage transfer have a high input impedance and low output impedance (a practical example is shown in Fig. 4).

Obtaining maximum voltage transfer is the usual reason for taking care over impedance matching. However, sometimes it is desirable to retain high current levels for efficient power transfer. It is difficult to explain optimum power transfer without differential calculus, so suffice it to say, to maximise the transfer it is necessary for the source resistance to equal the load resistance. This is far from true if we wish to concentrate on the current flow between stages. Here, assuming the output impedance is set, a low value for Z_{IN} is best – total resistance in the circuit must be kept to a minimum.

So, now we know how to measure impedance and why it's important to match stages, we'll take a brief look at the ways impedance can be manipulated.

Changing Your Outlook

Having measured the impedances of two stages and found a mismatch, what can be done? Well, there are a number of ways in which a low impedance can be changed to a high one and vice versa.

One easy, though not obvious, way of changing impedance – commonly found in low level audio – is to use a stepping transformer. Without going into the mathematics, a transformer can convert a high current, low potential into a high voltage signal with a low current. More usefully, it can change weak signal sources (eg microphones) into something approaching that required for amplification at a medium impedance input. The conversion formula refers to the turns ratio between the primary and

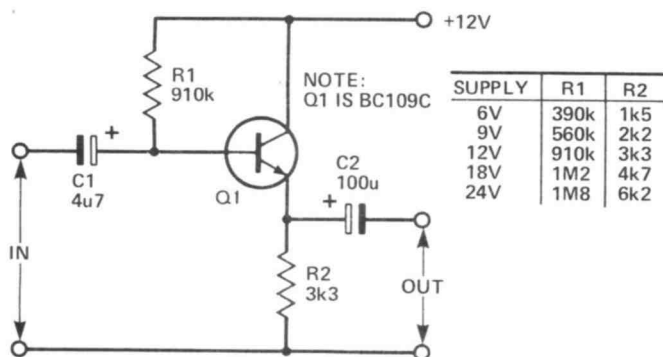
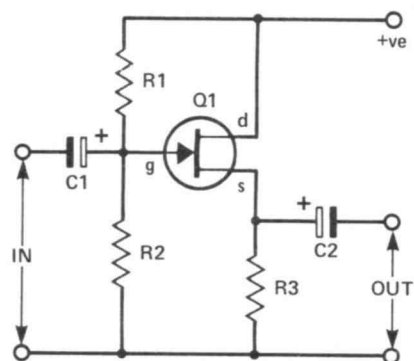

Figure 5: Experimental emitter follower with values for bias components at different supply voltages ($I_c = 2\text{mA}$, $h_{FE} = 300$).

secondary windings. It is equal to the square root of: the source, over the input, resistance; ie ratio = $\sqrt{(R_s/R_{IN})}$. Once this ratio has been calculated, the only other constraint is to ensure that the transformer has the right frequency characteristics for the signals involved. A bad choice here could jeopardise any benefits gained from the technique.

A more economical way of altering impedance, is to use an emitter follower stage (sometimes called "common collector", which offers a neat way of lowering output impedance. Considering the circuit of Fig. 5: at low to medium frequencies, the impedances are mostly resistive in nature. This means the input resistance, can be equated with load resistor (R_2) and h_{ie} products, in parallel with base resistor R_1 . The output impedance is also easy to ascertain, being source resistance over h_{ie} (in parallel with the load resistor if the signal source has a high output impedance).



(a)

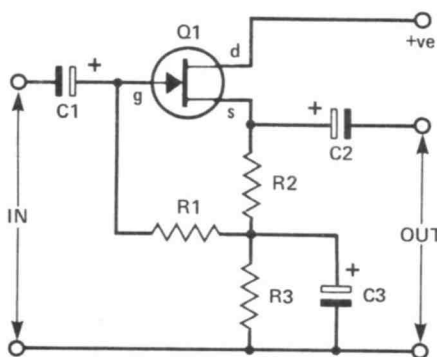

(b)

Figure 6. Two FET source followers. The uppermost circuit (a) is a basic version with bias resistors and (b) shows a better configuration using feedback and by-pass components.

Larger impedance conversions can be achieved using Darlington transistors (eg MPSA12) or two standard types in a Darlington configuration – the emitter from one feeds the base of the other (make sure the base resistor takes into account the higher value for h_{ie}). Another option is to use a field effect transistor, as a source follower, with its inherent high input impedance. The input impedance is then equal to the gate-to-earth resistance (for most purposes), and the impedance of the output is independent of signal source resistance. It's derived from the transconductance of the particular FET used (usually a few hundred ohms).

These are just a few ways you can modify input and output impedances. There are several others, including using op-amps, MOSFETs and feedback techniques (an example is shown in Fig. 6), but we hope the information provided here is enough to stimulate further investigations of your own.

■ R&EW

YOUR REACTIONS

	Good	Average	Poor
Circle No.	94	95	96

10 METRE BAND TRANSVERTER

Design by Graham Leighton.

This design for a 144MHz to 28MHz band transmit/receive converter is based on last month's 6M Transverter.

MANY OF YOU will have realised that the low power stages of the 6M transverter design are readily convertible for use on the 10 metre band. The inclusion of extra switching makes it possible to construct a low power 10 and 6 metre band transverter for use with a 144MHz transceiver.

Figure 1 shows the arrangement of the blocks used to form the 10M transverter. The main differences between the two versions are in the crystal frequency, the bandpass filter and the receive pre-amplifier. The only item for which we haven't yet published details is the 28-30MHz bandpass filter. These are given in Fig. 2. As in the 6M model this filter may be built on a preamp PCB. One point to note here is that the coils must be inserted with the lower end of the winding connected to earth. Photographs in the preamplifier article show the correct orientation.

Except for the frequencies involved the

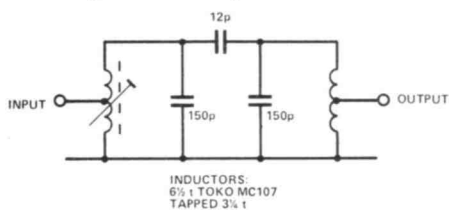

Figure 2: 28MHz Filter Circuit.

C1	70 - 350p
C2	55 - 300p
C5	7 - 100p
C6	55 - 300p
C11	70 - 350p
C12	24 - 400p
C21	70 - 350p

Table 1: Values for the ARCO trimmer capacitors.

Figure 3: Power Amplifier Circuit

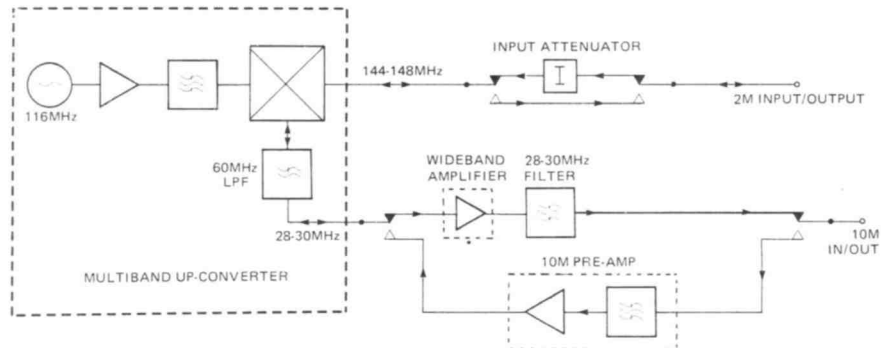
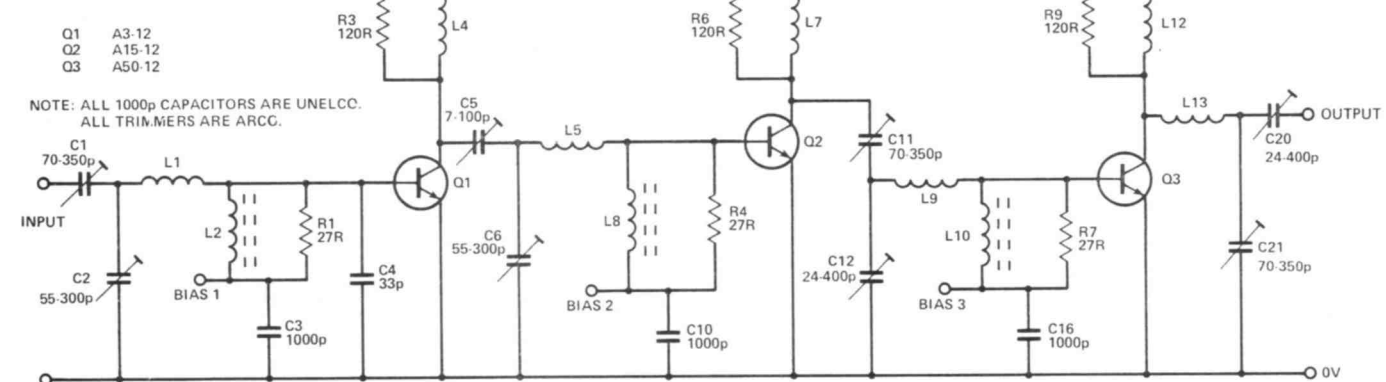

Figure 1: Block Diagram of 10M Transverter.

test and alignment instructions are the same as those for the 6M transverter. Since the bandpass filter is slightly overcoupled in order to give the full 28-30MHz coverage, care is needed in the adjustment of this filter. It is important to tune the coils for an even output level across the band. Using just the wideband amplifier on the transmit side the output power will be about 100-200mW.

An integrated transverter for the 6 or 10 metre bands is still planned for a future issue but the additional details presented here will give those who already have some of the modules, or who like to experiment, a starting point to work from. It is hoped that a 100 watt PA will be available for use with both this design and the single board transverter.

Unfortunately a few important details were omitted from last month's 6 metre transverter article. The power transistors

used in the PA were the following types: Q1, A3-12 Q2, A15-12; Q3 A50-12. These are all CTC devices which are difficult to obtain but as mentioned may be replaced with suitable HF SSB parts. The 100 watt power amplifier will use readily available transistors and will be much simpler. The trimmer capacitors used are all ARCO compression trimmers (see table 1).

Additional LF decoupling may be needed on the output of each PA bias network, tantalum capacitors are ideal.

■ R & EW

YOUR REACTIONS	Circle No.
Good	55
Average	56
Poor	57

DATONG

New

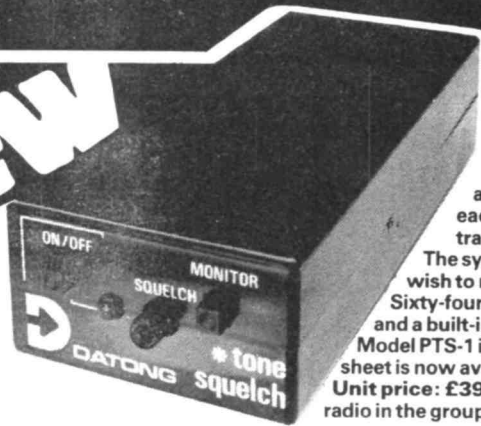

MODEL PTS-1

tone SQUELCH UNIT MODEL PTS-1

Designed to wire-in to the microphone and loudspeaker lines of existing FM or AM transceivers, Model PTS-1 provides a second independent squelch system.

The squelch operates only when the incoming signal carries a pre-arranged tone of precisely the correct frequency. Thus two transceivers, each fitted with Model PTS-1, will respond only to each others transmission protecting the user from undesired interruptions.

The system is ideal for Raynet groups, club nets, or groups of friends who wish to monitor for each others signals over long periods.

Sixty-four tones in the range from 1747 to 2330 Hz are selectable by a DIL switch and a built-in notch filter removes the tone from received signals.

Model PTS-1 is built to high standards using 9 ICs on a glass fibre PCB. A full data sheet is now available.

Unit price: £39.99 + VAT (£45.99 inclusive) (Note - a unit is required for each radio in the group).

COMPACT RECEIVING ANTENNAS MODELS AD270/370

Datong Active Antennas solve the age-old problem of finding space for a 'good' receiving aerial. Model AD370 mounted on a roof top or Model AD270 in a loft will give similar sensitivity to much larger conventional aerials yet are only 2 1/2 and 3 metres long respectively. Moreover they do not suffer from interference picked up by the feeder cable: such pick-up can be a problem with conventional dipoles because it is hard to maintain good balance over a band of frequencies.

Although active antennas were introduced to the amateur market by Datong only a few years ago they have long been used by military and commercial receiving stations. The performance specifications achieved by the Datong AD270/370 are very close to those of "professional" active antennas selling for ten times the price - a point which is not lost on our many professional customers.

MODEL AD270/370

The advanced design ensures two things: that you don't miss signals through inadequate sensitivity and that the antenna does not invent signals which are not there. Datong Active Antennas represent an advanced solution to a common problem and so far as we know have no serious competition in terms of performance at the price. (Reviewed in Rad. Com., June 1982).

GENERAL COVERAGE RECEIVER CONVERTER MODEL PC1

Once upon a time it was the norm to use a ten metre receiver to receive the two metre band. Now, large numbers of special purpose two metre SSB rigs are in use and conversion the other way becomes a very attractive possibility.

With the addition of Model PC1 each of these two metre SSB rigs becomes a really good general coverage receiver (from 50 kHz to 30MHz!). Two metre SSB rigs are not cheap and it makes good sense to get the most out of them. They also tend to have very good performance in terms of sensitivity, selectivity, and big signal handling. Each of these features is just as vital for short wave reception and Model PC1 is designed not to degrade them at all. The result, your two metre SSB rig receives below 30 MHz as well as it receives on two metres. And compared to many medium cost general coverage sets, that is saying a lot!

Try this test. Listen on twenty metres after the band goes dead in the evening. With many general coverage receivers the band never dies. It remains populated with phantoms generated by the receiver from the many very strong signals on forty metres. This is the kind of effect that the higher quality receivers minimise, and that goes for PC1 plus a good two metre rig. Reviews: Rad. Com., April 1982.



MODEL PC1

BROADBAND PREAMPLIFIER

MODEL RFA

Model RFA is designed to improve slightly 'deaf' receivers within the range 5 to 200 MHz. It includes r.f. activated in/out switching so that it can be used to improve the sensitivity of low power transceivers (less than 20 watts PEP) simply by connecting it in series with the aerial. Most receivers have nearly adequate sensitivity. Adding Model RFA will give a useful improvement in signal-to-noise ratios without causing too easy overload on strong signals. The gain is fixed at 9 dbfs for this reason.



MODEL RFA

Conventionally most preamplifiers have been designed for single narrow frequency bands. By using modern broadband techniques wide coverage is achieved without compromising the noise performance.

Model RFA is ideal for improving VHF scanners, HF receivers, mobile radio systems as well as for use on fixed amateur bands such as the 14, 21, 28, 56, 70 and 144 MHz bands.

HIGH PERFORMANCE 2 METRE CONVERTER

MODEL DC 144/28

Again strong signal performance is the key to the design of Model DC144/28.

Where conventional converters use a dual gate mosfet as a mixer, the Datong uses a balanced pair of Schottky diodes fed with nearly 10 mW of local oscillator at 116 MHz. Where other converters use open wound coils, the Datong coils are in screening cans on a plated through board.

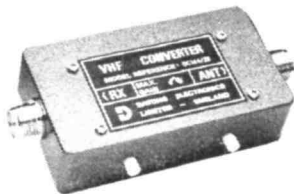

MODEL DC144/28

The result: an unusual freedom from spurious signals and overload effects together with a spurious-free dynamic range of 90 db.

As the Rad. Com. reviewer wrote "With a 3 db noise figure and 90 db dynamic range the Datong DC144/28 is one of the best 144 MHz converters currently available", Rad. Com., April 1982.

Model DC144/28 is available either as a tested PCB module, as illustrated, or fully cased in a diecast aluminium box.



ALL DATONG PRODUCTS ARE DESIGNED AND BUILT IN THE U.K.

PRICES

All prices include delivery in U.K. basic prices in £ are shown with VAT inclusive prices in brackets.

FL3	112.50	(129.37)	AD370	56.00	(64.40)	Codecall	
FL2 A	34.00	(39.67)	AD270+MPU	45.00	(51.75)	(Linked)	28.00 (32.20)
FL1	69.00	(79.35)	AD370+MPU	60.00	(69.00)	Codecall	
FL2	78.00	(89.70)	MPU	6.00	(6.90)	(Switched)	29.50 (33.92)
PC1	119.50	(137.42)	DC144/28	34.50	(39.67)	Basic DF System	149.00 (171.35)
ASP	72.00	(82.80)	DC144/28			Basic Mobile	
VLF	26.00	(29.90)	Module	28.00	(32.20)	DF System	159.00 (182.85)
D70	49.00	(56.35)	Keyboard Morse			Complete Mobile DF	
D75	49.00	(56.35)	Sender	119.50	(137.42)	System	214.00 (246.10)
RFC M	26.00	(29.90)	RFA	29.50	(33.92)	PTS1	39.99 (45.99)
AD270	41.00	(47.15)					

See previous advertisement or price list for further details.

Data sheets on any products available free on request - write to Dept R.E.W.

DATONG ELECTRONICS LIMITED

Spence Mills, Mill Lane, Bramley, Leeds LS13 3HE, England. Tel: (0532) 552461

163 for further details

VIDEO NEWS

Peter Luke
with big news
about a small camera.



A NEW COLOUR TV camera that is not much larger than the pistol grip of current cameras will soon be available in the UK. The camera is being produced by Konica in association with Ampex, the latter name having a long association with things video from the professional end of the market.

The camera plus cable weighs just 690 grams and produces a standard composite video signal and is thus suitable for use with any portable recorder.

The specification reveals that the camera offers most of the features offered on its larger brethren, with the possible exception of a 'fine tuning' control for the white balance. Zoom range is also rather limited when compared to the six to one range that seems to be the standard today. The camera, despite its small size, does manage to squeeze in a microphone however.

The viewfinder shown in the photograph is an optional extra and features a 1" CRT. It, like the camera, is both small in size and, at 212g, light in weight. The camera/viewfinder combination is in fact significantly less than a kilogram in weight – even some of the frail looking ladies that PR companies are so fond of using should be able to cope with that without arm ache.

Specifications of the KONICA COLOUR VC

* Television system:	NTSC colour signal EIA standards, 525 lines, 60 fields, 30 frames
Image pick-up:	Single carrier frequency separation method
Pick-up tube:	1/2" electrostatic focusing magnetic deflection type SATICON (S-M type SATICON)
Horizontal resolution:	250 lines plus
Image signal-noise ratio:	45dB plus
Minimum required illuminance:	100 lux
White balance:	3 position switch (internal colour filters)
Microphone:	Built-in, non-directional electret condenser microphone
Audio output:	-20dB, high impedance
Lens:	F1.8, f=10-30mm manual zoom lens
Aperture control:	Automatic iris, closed when not in operation
Focusing:	Manual, click stop at pan-focus position
Finder:	TTL optical system, low light warning, LED signal on when recording, eyepiece shutter
Power source:	DC 12V
Power consumption:	4.1 watts
Dimensions:	W 58mm X H 199mm X D 106.5mm
Weight:	690 grams (including cable)
(Optional)	
Electronic viewfinder:	1" CRT, 0.95W power consumption, 212g weight

*N.B. Specification relates to the current production for the Japanese and U.S.A. markets. European specification (PAL system) will be available shortly.

PAL Plus

The likelihood of cable and satellite TV systems becoming a reality in the next few years has prompted the BBC, amongst others, to take a look at the present PAL transmission standard with the benefit of having used the system for over ten years. One of the drawbacks of the PAL system are the cross-colour effects that are the result of high frequency luminance signals interfering with the chroma information at 4.43MHz. The increased bandwidth that satellite systems will make available has kindled an interest in alternative colour encoding techniques one of which is known as extended PAL.

Standard PAL broadcasts transmit video signals ranging up to some 5.5MHz with the chroma information on a subcarrier at about 4.43 MHz. Extended PAL separates the low frequency video (up to about 4MHz) from the HF content which is shifted to a higher frequency. The signal is in fact shifted by the 4.43MHz of the colour subcarrier, meaning that the subcarrier can be used as the local oscillator signal at the receiver.

The modulated chroma information now has sole occupancy of the spectrum around 4.43MHz removing the interference that produces cross-colour effects.

The system also has room, between 6 and 8MHz for digitally encoded sound to be transmitted along with the video signals.

One of the major attractions of the extended PAL system is that it is fully compatible with existing TV receivers. The current generation of receivers are not capable of resolving the information contained within the HF signal and thus Extended PAL transmissions will be displayed with no loss of definition and without cross-colour effects.

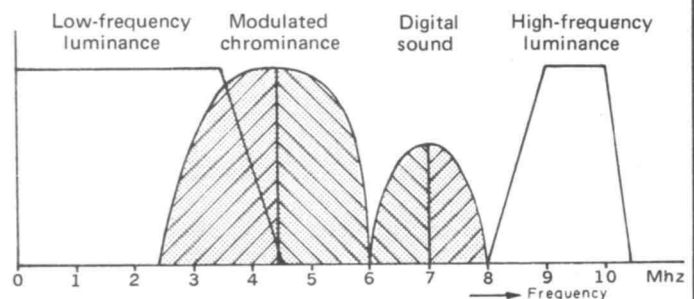

Figure 1: Extended PAL signal spectrum.

The extra circuitry needed to convert a standard set into a receiver capable of decoding.

Extended PAL is minimal – a HP filter, mixer, LP filter and that's about it – making the system an attractive proposition when it comes to improving the current PAL standard. ■ R&EW

YOUR REACTIONS

	Good	Average	Poor
Circle No.	79	80	81

MULTI-CHECK TEST PROBE

This handy device is a perfect complement to a multi-meter.

The multi-check provides LED indication of both AC and DC voltages in the range 6V to 415V - in the case of DC voltages, polarity is indicated.

An internal battery also means that the device can be used to check a circuit's continuity (in the range 0 to 20k). The robust construction of the tester means that it is perfect for use in the field, it's also useful for bench use if the precise indication of a multi-meter is not required.

- * LED indication of voltages in the range 6V - 415V
- * Polarity indication
- * Continuity testing
- * Robust construction

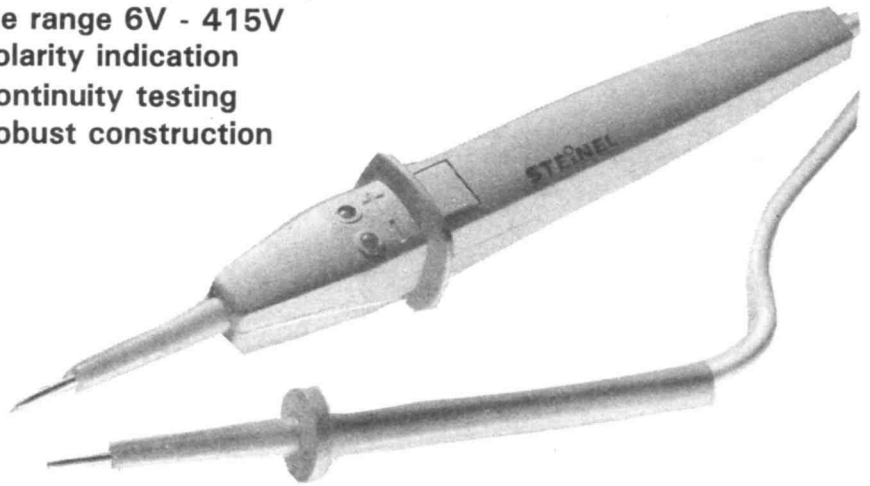

ONLY £9.95

TWO SPECIAL OFFERS FROM R&EW

Both these high quality products are available for only £9.95 each, fully inclusive of VAT and postage and packing.

- * One system for most tasks
- * Low running costs
- * Fully Guaranteed
- * No mess



ONLY £9.95 COMPLETE WITH 10 GLUE STICKS.

Plus 30% discount on your first order of glue sticks.

BUY BOTH FOR AN ALL-IN PRICE OF £18.95

GLUE FIX 2000 - TOMORROW'S WORLD

ELECTRONICALLY CONTROLLED GLUE GUN FOR HOT MELT ADHESIVES.

Super Glue?, Epoxy?, contact?-choosing the RIGHT adhesive for a particular task can be quite a problem. Now **R&EW**, in conjunction with Steinel, offers readers a hot melt glue system that can achieve excellent results in most applications-no more confusion over adhesive types.

The initial cost of the glue fix gun is quickly recouped as the cost of the adhesive is far less than conventional glues-there's no waste either and no returning to a tube of glue only to find its 'gone solid'.

The contact-less operation of the PTC heating element means the gun is maintenance free. The gun is also fully guaranteed against faulty manufacture.

The glue gun will be supplied with an initial supply of ten glue sticks.

How to order: fill in the coupon below in BLOCK letters and send, with your crossed cheque/Access/Barclaycard No., or P.O. made payable to Radio & Electronics World, to R&EW Special Offers, 200 North Service Road, Brentwood, ESSEX, CM14 4SG. Please allow 21 days for delivery.

Name:	
Address:	
.....	
.....	
	Quantity
Test probe @ £9.95 each	<input type="checkbox"/>
Glue fix 2000 @ £9.95 each	<input type="checkbox"/>
Test probe & glue fix 2000 @ £18.95	<input type="checkbox"/>
Cheque/P.O. No.	
Access/Barclaycard No.	
Signature	

character - 9×6 pixels including spaces) per line with 24 lines per frame is possible. This allows a sampling error of up to 1 triad per pixel.

Construction

We chose a Thorn TX9 television receiver to use for the conversion. The chassis was modified by removing the UHF tuner, intermediate frequency amplifier module and also the sound and video processing IC's. This was carried out to save current consumption to allow the additional components to use the existing receiver power supply.

A buffer amplifier board was designed for the red, green and blue input signals, to drive the output stages which in turn drive the tube. A buffer amplifier was also provided for the synchronisation circuits.

The existing beam current limiter circuit was reconfigured to make it compatible with the new interface circuit. A 'C' core mains transformer was fitted to give low external magnetic flux radiation preventing CRT scanning or colour purity errors and giving safety isolation. The monitor was fitted to a 19" (49cm) rack mounting cabinet.

Principle Of Operation

The operation of the monitor is as for the TX9 with the exception of the following modifications:

Four signals are received at the monitor; they consist of three video signals with amplitudes of 1 volt peak-to-peak positive going. The fourth signal is a synchronisation signal of 2 V peak-to-peak negative going.

The buffer amplifier increases the video signal to a level of 3.5 V peak-to-peak to drive the Class A video output transistors, which drive the cathodes of the tube.

Variable attenuation of each of these buffer video amplifiers provides contrast control and further components are used for adjustment of brightness.

Design changes have been made to the original beam limiter circuit so that the new contrast and brightness control circuits

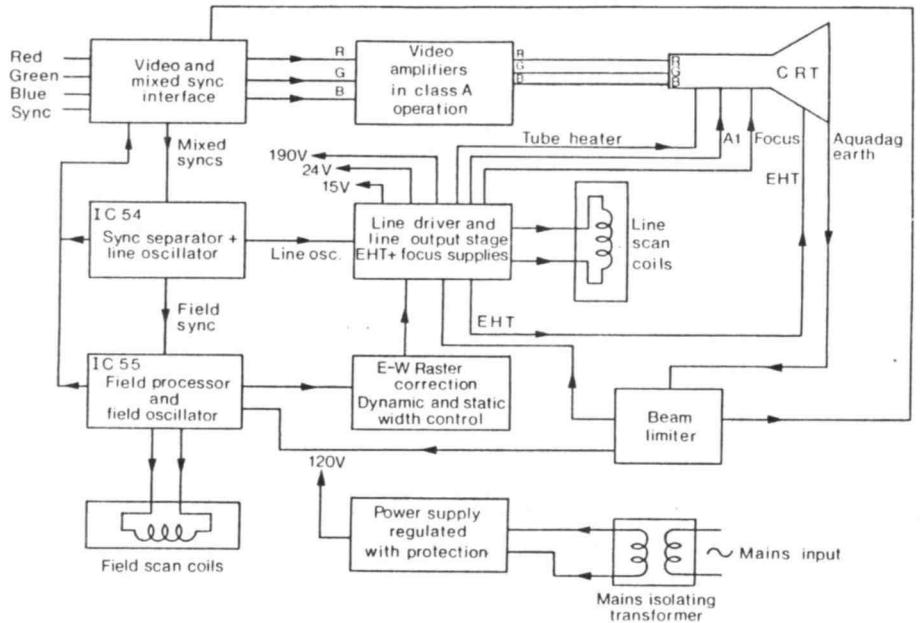

Figure 3: Complete monitor block diagram.

may track with the limiter, ensuring that the total beam current of the tube does not exceed 600 μ A.

A block diagram schematic Fig. 3 shows the arrangement of the complete monitor.

Circuit Description

It is conventional practice to distribute video signals via co-axial cable having a characteristic impedance of 75 Ω carrying signal amplitudes of 1 V peak-to-peak.

Six BNC sockets provide connections to the monitor. Loop-through facilities are provided for forward linking these signals to other monitors. Change-over switches select this option and simultaneously remove local line termination as shown in Fig. 4.

All three video amplifiers are identical in design having a bandwidth of over 70 MHz (Fig. 5).

Video signals are AC coupled, via C1 to the base of Q1 and the amplifier has a gain of 3. C4 and C5 AC couple through the base of Q3 emitter follower.

The contrast of the picture is proportional to the signal gain - by reducing the amplitude the contrast will decrease. Q4 is a JFET device operating as a variable attenuator controlled by the contrast potentiometer. The contrast potentiometer provides a common control for Q8 and Q12. Picture brightness is controlled by altering the base voltage of the emitter follower Q3.

Figure 6 (a) and 6 (b) show the frame and line blanking circuits.

Q15 amplifies frame and line blanking pulses, which are fed to Q3 via D1 turning the video amplifiers off on flyback, Fig. 6(a).

External synchronising pulses have termination and loop through facilities available on BNC sockets similar to the video inputs. The sync signals have a amplitude of 2 V peak-to-peak negative going. Positive going signals are required to drive the already existing sync circuits. The input signal is inverted by Q13 and buffered by emitter follower Q14, Fig. 6 (b).

The 14" tube, used in the monitor, has a beam current limit set to 600 μ A to protect the tube from excessive heating of the shadowmask (which would cause purity errors) and to give good control of EHT.

The beam current limiter prevents the tube exceeding a certain value, controls the maximum power dissipation of the receiver and controls picture size. When any of these errors are detected by the limiter circuit both brightness and contrast are reduced proportionally by applying a control voltage to the video processing IC.

As the modified receiver does not use the video processing IC, the beam limiter was adapted for use with the new interface board and controls the gain of the RGB buffer amplifiers by off-setting the gate potential on the variable FET attenuators (Fig. 7).

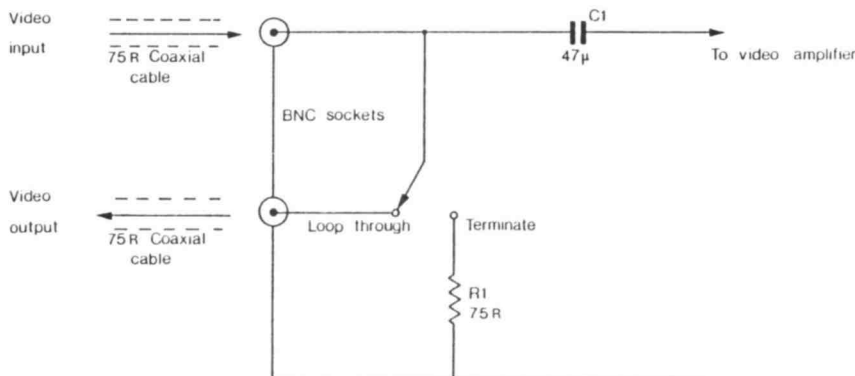

Figure 4: Termination of video signal.

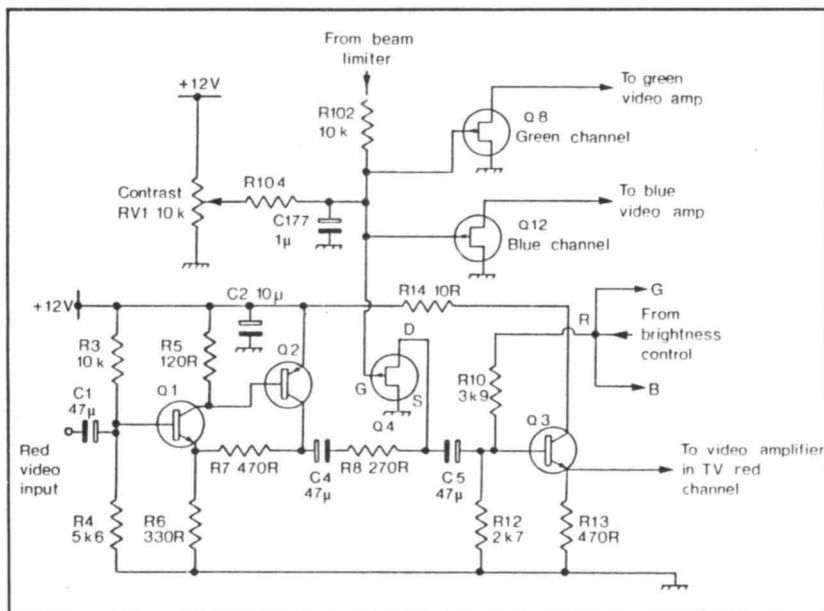

Figure 5: Red channel video amplifier circuit.

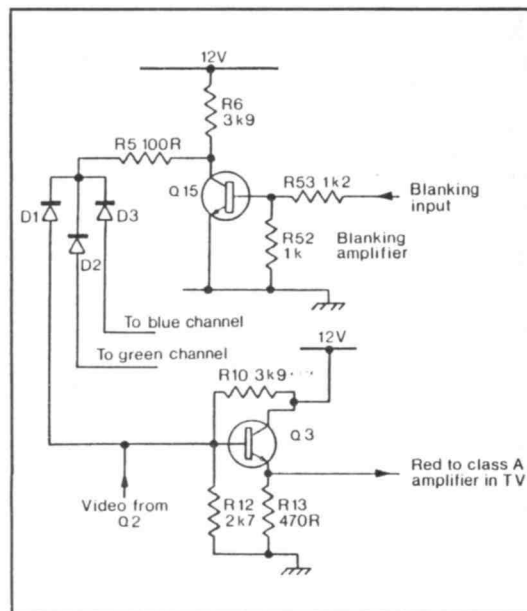

Figure 6 (a): Blanking amplifier circuit.

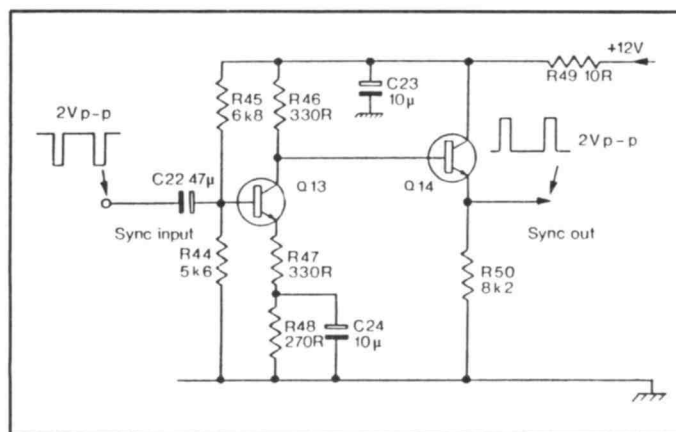

Figure 6 (b): Sync inverter and amplifier circuit.

Testing And Alignment

The monitor was set up using the Philips PM5519 colourbar and pattern generator in conjunction with a Link Electronics PAL decoder 228/567.

The picture was underscanned both vertically and horizontally to enable data at the very edge of the scan to be identified. Greyscale tracking and linearity adjustments were made in accordance with the manufacturers' instructions. Particular emphasis was made setting the supply line voltage, as any inaccuracy would be reflected in the tube heater supply (derived from the line output stage) subsequently reducing the line of the instrument.

Cathode ray tubes operated with a final anode volts of more than 25 kV can, under certain circumstances, emit forward x-ray radiation. Although the manufacturers of the television design well below these parameters, with a final mode of 24kV, the radiation level was monitored since the receiver had been modified.

An EMI RM2 ratemeter was used to measure forward x-ray radiation at the screen face and core. The measurements were well within the international safety limit of 0.5 MR/h at maximum beam current.

Final anode voltage was monitored simultaneously using a Bradenburg 88M EHT meter and did not exceed 24 kV.

The metal cabinet of the monitor was assembled in sections and bolted together; a separate earth bonding cable was attached to each panel and returned to a common earth to provide extra safety.

The power supply uses a bridge rectifier connected across the mains input which makes the chassis live irrespective of mains polarity. An isolating transformer was introduced into the mains supply to ensure safety and allow mains earthing to the cabinet.

The monitor has been further developed for use with the new range of high resolution CRT displays which enable a better quality picture using a super fine matrix with phosphor dot pitch of 0.3mm.

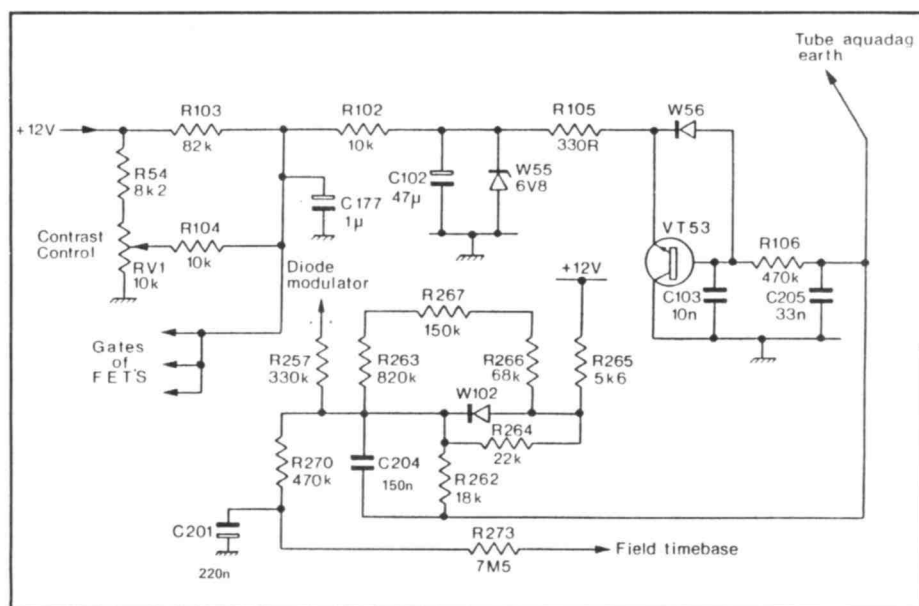
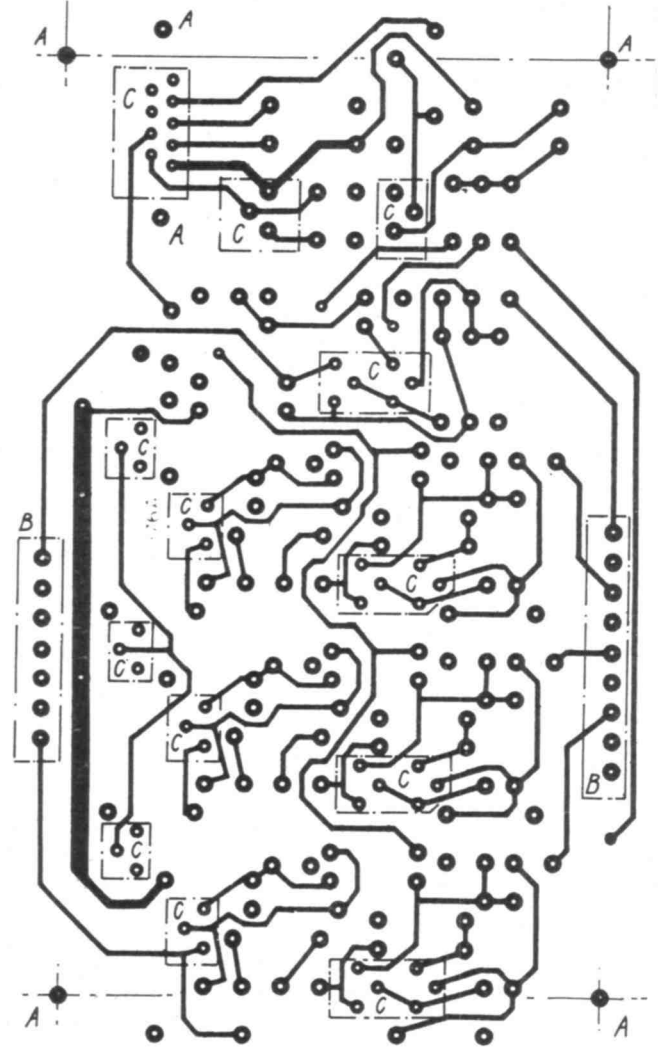
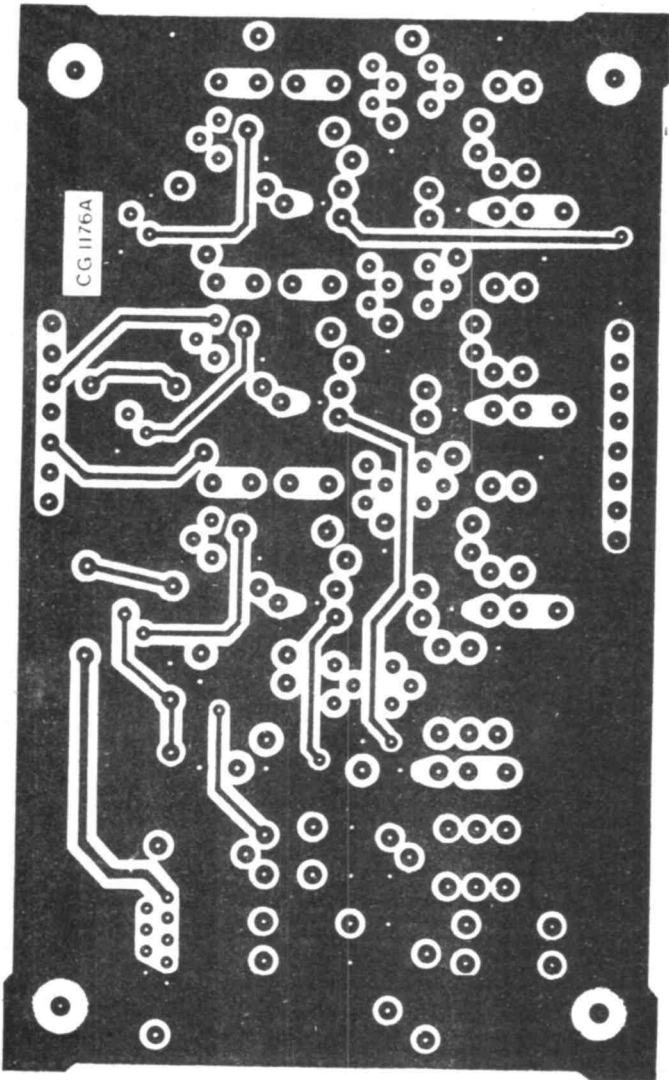

Figure 7: Beam limiter circuit.



Foil patterns for both sides of the PCB.

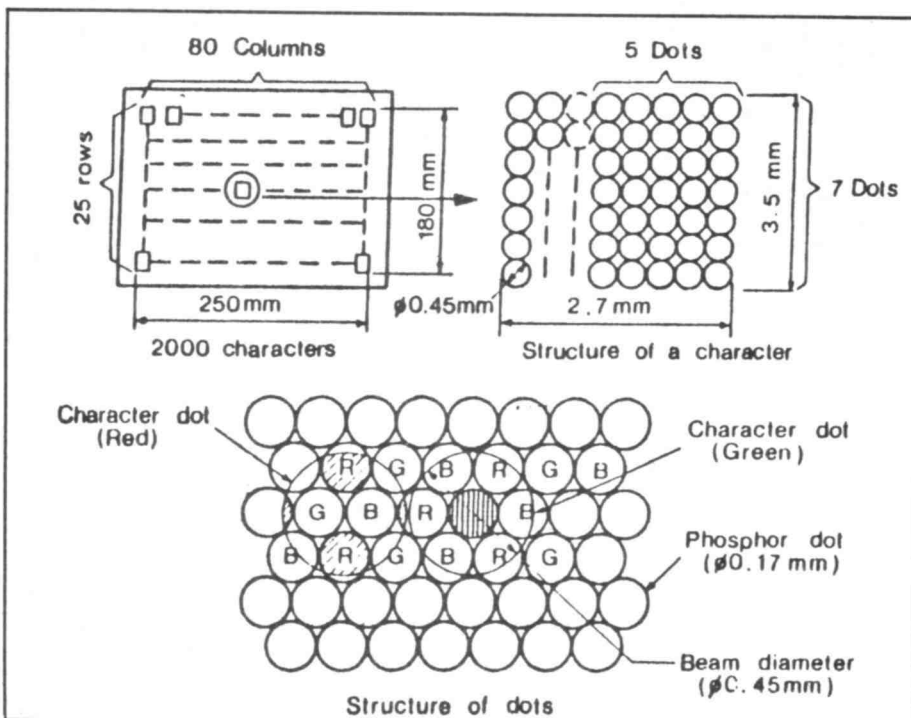

Figure 8: High resolution colour tube dot structure.

These display 24 lines of 870 characters at a total of 2000 characters (the figures are for good resolution including redundancy. More characters could be displayed but with deterioration in quality, Fig. 8).

The luminance output is lower from a high resolution tube, because of the fine pitch shadowmask, and beam current is also reduced.

Circuit modifications were necessary to limit the beam current to 450 μ A and the value of two components were changed to compensate for a difference of line-scan coil inductance associated with the new tube.

The modification of domestic TV sets has proved a cost effective method of providing low-cost colour graphics monitors. Many of these monitors have been installed giving good performance and high reliability.

It has also been demonstrated that the provision of a high definition colour tube to the monitor is a practical solution to the provision of low cost high definition monitors.

Specifications

EC581

Employs 14" tube incorporated in lightweight plastic case.

EC582

Employs 14" tube incorporated in aluminium case designed for 19" (49 cm) rack mounting.

DISPLAY

90d rectangular glass picture tube. Featuring a perfectly rectangular screen of 3×4 aspect ratio. Inherent self converging system with integral saddle toroidal yoke. In line gun slotted shadowmask which is temperature compensated. Hybrid type black stripe screen giving high level of brightness and contrast. EHT 24 kV at zero beam current Quick start cathode.

Implosion Protection

Integral.

X-Radiation

Less than 0.5 mR/H.

Scanning System

CIR 625 line.

Degauss

Automatic on switch. On.

Inputs

All bnc sockets 75 Ω with loop through.

Input Levels

Red, Green and Blue inputs each require a video signal of 1 V peak-to-peak (positive going video). Sync input requires 2 V peak-to-peak negative going syncs.

COMPONENTS: The printed circuit board, with full parts list and overlay details, is available from:

A.S.Warne,
113 Queen's Road,
Vicars Cross,
Chester.

Write enclosing SAE for further information and prices.

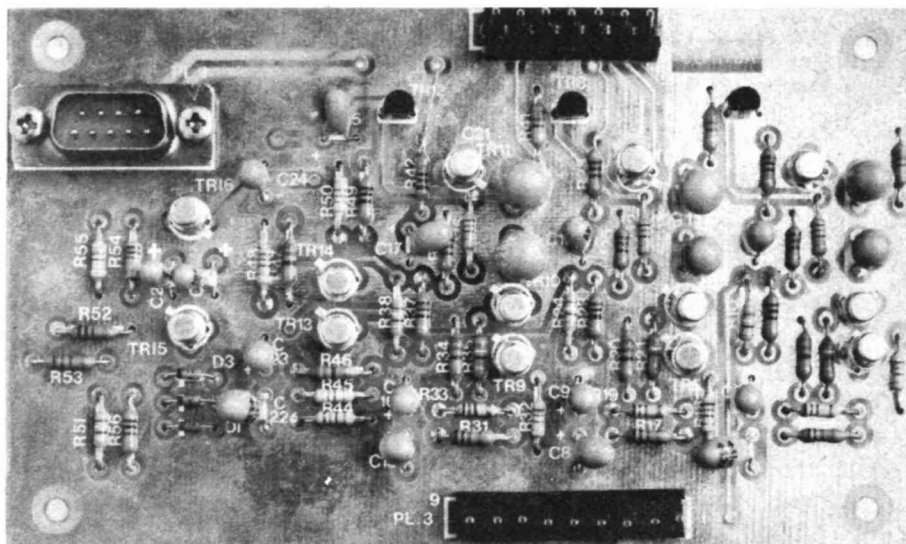

Interface printed circuit board.

References

1. 3X030, 80VA, 240v secondary. ILP Electronics Ltd., Graham Bell House, Roper Close, CANTERBURY, Kent. CT2 7EP.

2. VT24825 isolating transformer. St. Ives Windings Ltd., Industrial Estate, Somersham Road, ST. IVES, Cambs.

Particular thanks to Mr. K.P. Cope for assistance and helpful discussions in the design of wideband circuits and to Dr. M.M. Przybylski for his general assistance. Finally, we thank the Science and Engineering Council, Davesbury Laboratory for permission to print this article.

■ R&EW

Acknowledgements

Our thanks to the members of Thorn EMI design and development team, at the Bradford Engineering Centre, for the information and assistance they have given and their permission to reprint part of the service information for the TX9.

YOUR REACTIONS	Circle No.
Good	7
Average	8
Poor	9

SUBSCRIPTIONS

With the increase in our cover price this month we have had to adjust our subscriptions rates accordingly.

The new rates are as shown below:

UK (12 issues) £13:00

Overseas (12 issues)

£13:50

If you want to be sure of getting YOUR copy of Britain's most informative Radio/Electronics magazine, PLAY SAFE AND SUBSCRIBE. Fill in the form below.

SUBSCRIPTION ORDER FORM

I would like to subscribe to **Radio & Electronics World** for one year (12 issues). Please start my subscription from the _____ issue.

SUBSCRIPTION RATE:
(tick ✓ as appropriate)

UK £13.00 for 12 issues
Overseas £13.50 for 12 issues

PAYMENT:

(Access/Barclaycard orders may be sent using reply paid order card)

I enclose my (delete as necessary) Cheque/Postal Order/
International money order for £

Please use **BLOCK CAPITALS** and include postal codes.

Name (Mr/Mrs/Miss) _____

Address: _____

Signed: _____

Date: _____

Please send this order form, with your remittance, to Radio & Electronics World, Subscriptions Department, 45, Yeading Avenue, Rayners Lane, Harrow, Middlesex. HA2 9RL

Take me to your NEWSAGENT

Newsagents often run out of copies of R&EW simply because it is the best value for money electronics magazine around.

To make sure you don't miss a single issue, why not fill out the coupon and your newsagent will reserve a copy of every month's magazine ready for you to pick up at your leisure.

Fill out the coupon NOW and drop it in when you pick up your morning paper.

NEWSAGENT:

Please reserve me a copy of the
FEBRUARY 1983

RADIO & ELECTRONICS WORLD
and every succeeding issue until
further notice.

Name:

Address:

.....

.....

After passing through the ceramic filter, the IF signals are applied to the IF input. Signals at pin 11 are amplified by two AGC controlled common-emitter stages and then applied to the PNP output stage connected to pin 13. Biasing is arranged so that the current in the first two stages is set by the difference between the 250uA current source and the Darlington device connected to pin 12.

When the AGC threshold is exceeded, the Darlington device turns ON, steering current away from the IF into ground, reducing the IF gain. Current in the IF is monitored by the mixer AGC circuit. When the current in the IF has dropped to 30uA, corresponding to the 30dB gain reduction in the IF, the mixer AGC line begins to draw current. This causes the mixer current and input impedance to drop, as previously described.

The IF output is level shifted and then peak detected at detector cap C1. By loading C1 with only the base current of the following device, detector currents are kept low. Drive from the AGC is taken at pin 14, while the AM detector output is summed with the FM detector output at pin 17.

FM Section

The FM section is composed of a 6-stage limiting IF driving a quadrature detector. The IF stages are identical with the exceptions of the input stage, which is run at higher current to reduce noise, and the last stage, which is switched OFF in the AM mode. The quadrature detector collectors drive a level shift arrangement which allows the detector output load to be connected to the regulated supply.

Audio Amplifier

The audio amplifier has an internally set voltage gain of 120. The bandwidth of the audio amplifier is reduced in the AM mode so as to reduce the output noise falling in the AM band. The bandwidth reduction is accomplished by reducing the current in the input stage.

Regulator

A series pass regulator provides biasing for the AM and FM sections. Use of a PNP pass device allows the supply to drop to within a few hundred millivolts of the regulator output and still be in regulation.

FM IFT B

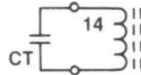

F = 10.7 MHz, CT = 51 pF, Qu = 110 ± 20%
Part No. NS-107C Apollo Electronics Corp.

AM ANT COIL

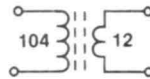

F = 10.7 MHz, CT = 82 pF, Qu = 70 over
Part No. KAC K2318HM Toko Electronic Ltd.

AM OSC

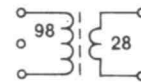

L = 650 uH, Qu = 250 at 796 kHz
Part No. LAM-650 Apollo Electronics Corp.

AM IFT A

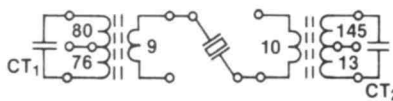

L = 360 uH, F = 796 kHz, Qu = 140
Part No. RB06A5105 Toko Electronic Ltd.

FM IFT A



F = 455 kHz
Part No. CFU-090D
Toko Electronic Ltd.

AM IFT B

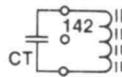

F = 455 kHz
CT = 180 pF, Qu = 14
Part No. 159GC-A3785 Toko Electronic Ltd.

LM3911 Temperature Controller - National

The LM3911 is an accurate temperature measurement and/or control system for use over a -25°C to +85°C temperature range. It includes a temperature sensor, a stable voltage reference and an operational amplifier.

The output voltage of the LM3911 is directly proportional to temperature in degrees Kelvin at 10 mV/°K. Using the internal op amp with external resistors any temperature scale can be easily obtained. By connecting the op amp as a comparator, the output will switch as the temperature transverse the set-point making the device

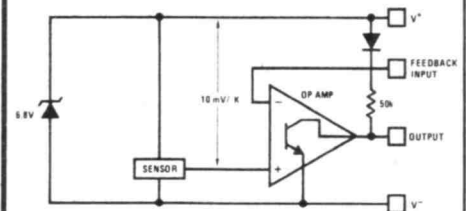

useful as an on-off temperature controller.

An active shunt regulator is connected across the power leads of the LM3911 to provide a stable 6V8 voltage reference for the sensing system. This allows the use of any power supply voltage with suitable external resistors.

The input bias current is low and relatively constant with temperature, ensuring high accuracy when high source impedance is used. Further, the output collector can be returned to a voltage higher than 6V8 allowing the LM3911 to drive lamps and relays up to a 35V supply.

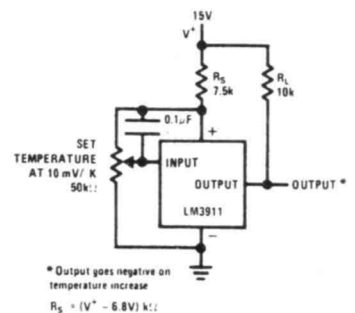

* Output goes negative on temperature increase
Rs = (V - 6.8V) k

LH0091 True RMS to DC Converter - National

General description

The LH0091, rms to dc converter, generates a dc output equal to the rms value of any input per the transfer function.

The device provides rms conversion to an accuracy of 0.1% of reading using the external trim procedure. It is possible to trim for maximum accuracy (0.5 mV ± 0.05% typ) for decade ranges ie, 10mV → 100 mV, 0.7V → 7V, etc.

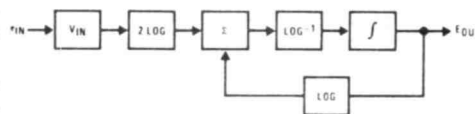

Application Hints

The internal reference regulator provides a temperature stable voltage for offsetting the output or setting a comparison point in temperature controllers. However, since this reference is at the same temperature as the sensor temperature changes will also cause reference drift. For application where maximum accuracy is needed an external reference should be used. Of course, for fixed temperature controllers the internal reference is adequate.

LM2907 Frequency to Voltage Converter - National

The LM2907 is a monolithic frequency to voltage converter with a high gain op amp/comparator designed to operate a relay, lamp or other load when the input frequency reaches or exceeds a selected rate. The tachometer uses a charge pump technique and offers frequency doubling for low ripple, full input protection and its output swings to ground for a zero frequency input.

General Description

The op amp/comparator is fully compatible with the tachometer and has a floating transistor as its output. This feature allows either a ground or supply referred load of up to 50 mA. The collector may be taken above VCC up to a maximum VCE of 28V.

Applications Information

The LM2907 series of tachometer circuits is designed for minimum external part count applications. This first stage of operation is a differential amplifier driving a positive feedback flip-flop circuit. The input threshold voltage is the amount of differential input voltage at which the output of this stage changes state. One input is internally grounded so that an input signal must swing above and below ground and exceed the input thresholds to produce an output. This is offered specifically for magnetic variable reluctance pickups which typically provide a single-ended AC output. This single input is also fully protected against voltage swings to $\pm 28V$, which are easily attained with these types of pickups.

The differential input options give the user the option of setting his own input switching level and still have the hysteresis around that level for excellent noise rejection in any application. Of course in order to allow the inputs to attain common-mode voltages above ground, input protection is removed and neither

input should be taken outside the limits of the supply voltage being used. It is very important that an input does not go below ground without some resistance in its lead to limit the current that will then flow in the epi-substrate diode.

Following the input stage is the charge pump where the input frequency is converted to a dc voltage. To do this requires one timing capacitor, one output resistor, and an integrating or filter capacitor. When the input stage changes state (due to a suitable zero crossing or differential voltage on the input) the timing capacitor is either charged or discharged linearly between two voltages whose difference is $V_{CC}/2$. Then in one half cycle of the input frequency or a time equal to $1/2 f_{IN}$ the change in charge on the timing capacitor is equal to $V_{CC}/2 \times C1$. The average amount of current pumped into or out of the capacitor then is:

$$\frac{\Delta Q}{T} = I_{C(AVG)} = C1 \times \frac{V_{CC}}{2} \times (2f_{IN}) = V_{CC} \times f_{IN} \times C1$$

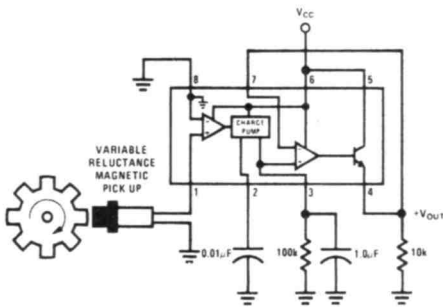

The output circuit mirrors this current very accurately into the load resistor R1, connected to ground, such that if the pulses of current are integrated with a filter capacitor, then $V_O = I_C \times R1$, and the total conversion equation becomes:

$$V_O = V_{CC} \times f_{IN} \times C1 \times R1 \times K$$

Where K is the gain constant - typically 1.0.

The size of C2 is dependent only on the amount of ripple voltage allowable and the required response time.

Choosing R1 and C1

There are some limitations on the choice of R1 and C1 which should be considered for optimum performance. The timing capacitor also provides internal compensation for the charge pump and should be kept larger than 100 pF for very accurate operation. Smaller values can cause an error current on R1, especially at low temperatures. Several considerations must be met when choosing R1. The output current at pin 3 is internally fixed and therefore $V_O/R1$ must be less than or equal to this value. If R1 is too large, it can become a significant fraction of the output impedance at pin 3 which degrades linearity. Also output ripple voltage must be considered and the size of C2 is affected by R1. An expression that describes the ripple content on pin 3 for a single RIC2 combination is:-

$$V_{RIPPLE} = \frac{V_{CC} \times C1}{2 \times C2} \times 1 - \frac{V_{CC} \times f_{IN} \times C1}{12} \text{ pk - pk}$$

It appears R1 can be chosen independent of ripple, however response time, or the time it takes V_{OUT} to stabilize at a new voltage increases as the size of C2 increases so a compromise between ripple, response time, and linearity must be chosen carefully.

As a final consideration, the maximum attainable input frequency is determined by VCC, C1 and I2:

$$f_{MAX} = \frac{I_2}{C1 \times V_{CC}}$$

LM1303 Stereo Preampifier - National

The LM1303 consists of two identical operational amplifiers constructed on a single silicon chip. Intended for amplification of low-level stereo signals, the LM1303 features low input noise voltage, high open-loop voltage gain, large output voltage swing and short circuit protection.

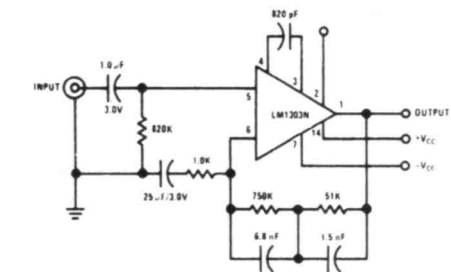

- Voltage gain 34 dB at 1 KHz
- Input overload point 100 mVrms at 1 KHz
- Output voltage swing 5.0 Vrms at 1 KHz and 0.1% THD
- Output noise level Better than 70 dB below 10 mV phono input (input shorted)

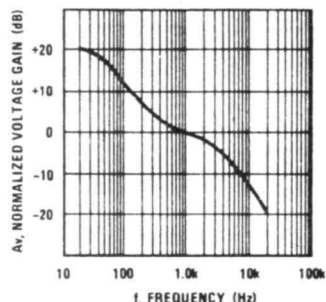

TCA5500 Stereo Sound Control System - Motorola

The TCA5500 is a single chip stereo balance, volume, bass and treble control circuit designed for use in car radios, TV and audio systems. Simple DC inputs allow the control to be effected by four potentiometers or a remote control system. The bass and treble responses are defined by a single capacitor per control per channel.

- Four high impedance DC controls - Vol., Bass, Treble, Balance
- A single external capacitor defines each tone control's characteristic.
- low distortion, 0.1% at nominal input level, 12dB gain with the tone controls flat.
- Channel separation better than 45dB.
- Wide power supply tolerance, 8 to 18V DC
- ± 14 dB of tone control
- More than 75dB of volume control
- Wide dynamic range: 25mV to 150mV RMS input signal
- Low output impedance
- Easily added loudness compensation

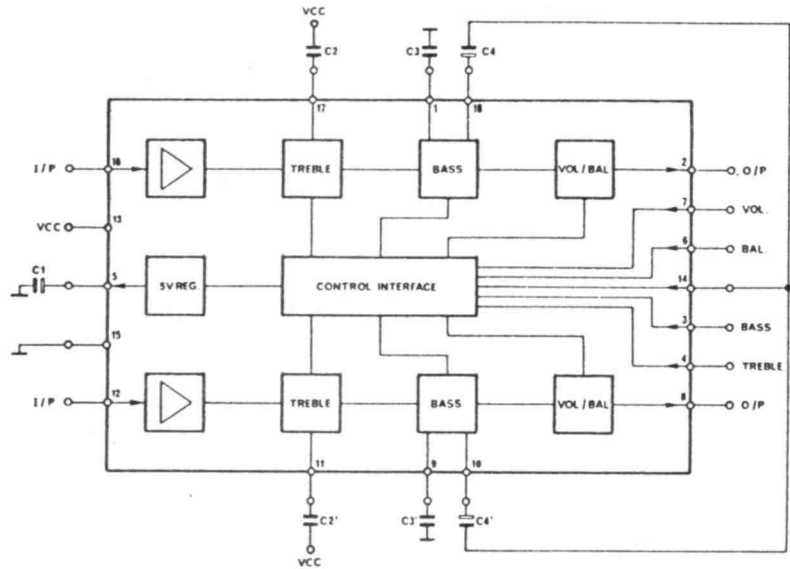

Finally - a couple of devices that are so new that full details of their performance are not yet available.

UAA2011 TV Time Base Circuit - Motorola

The UAA2011 is a dual loop time base with the line oscillator running at 125 KHz, followed by a divide by 8 counter for line frequency. Frame frequency is derived by counting down from the line oscillator.

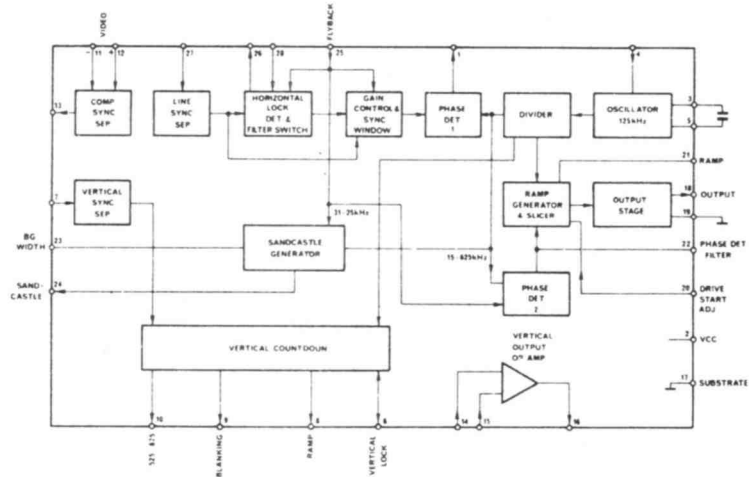

MC3333 Vari-Dwell Ignition Circuit

designed for use in conjunction with a flux averaging sensor and a high energy ignition coil to provide regulated current pulses to the coil from information supplied by the sensor.

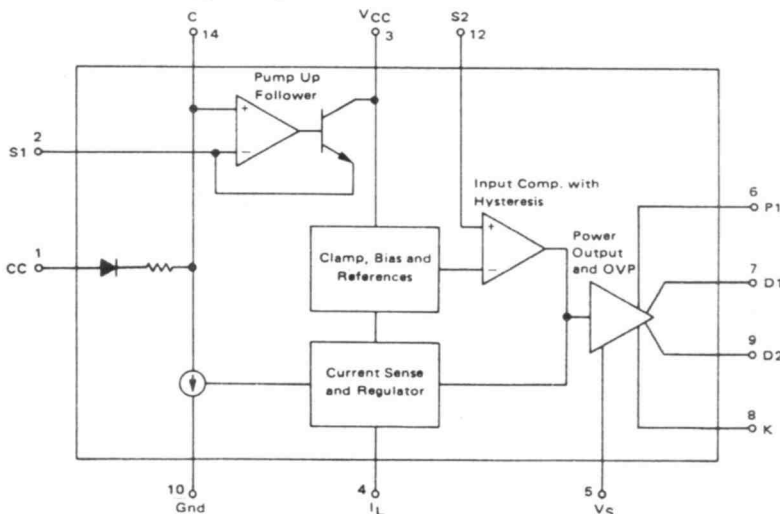

TDA3300B TV Colour Processing System - Motorola

The TDA3300 is Motorola's third generation colour processing system. The device will accept a PAL or NTSC composite video signal and output the three colour signals - needing only a simple driver amplifier to interface with the picture tube. There are also four inputs for On-Screen Display and the complementary fast blanking for use with teletext, viewdata, TV games, cameras etc.

YOUR REACTIONS	Circle No.
Good	49
Average	50
Poor	51



CMOS KEYSER

An Electronic Morse Code Sender with Integral Paddle by Tony Bailey G3WPO

FOR THOSE who have difficulty in sending recognisable morse code with a straight key, there is no doubt that the evolution of the electronic keyer has provided many users with the opportunity to send good code – even the best keyers can send rubbish in the wrong hands! Purists may argue that the electronic key has taken away the artistic individuality of the operators fist. Another argument is “Who needs CW anyway?” but that’s a

contentious issue – the author actually likes the mode!

Many different designs have been published over the years; ranging from simple one transistor circuits (providing the dots only), to the latest lambic keyers with multiple memories, anti-echo, last character stores and other features. All a bit confusing for the newcomer who has just passed the morse test.

The author set out to produce a

straightforward unit, suitable for the beginner or someone just graduating to an electronic keyer, with the essential features and a simple paddle design. The latter has been integrated into the PCB design and does not require any advanced workshop facilities (lathes, milling machines etc). The design allows paddle-only or keyer-only construction.

Four CMOS integrated circuits are used, consuming only 400uA (quiescent) from a

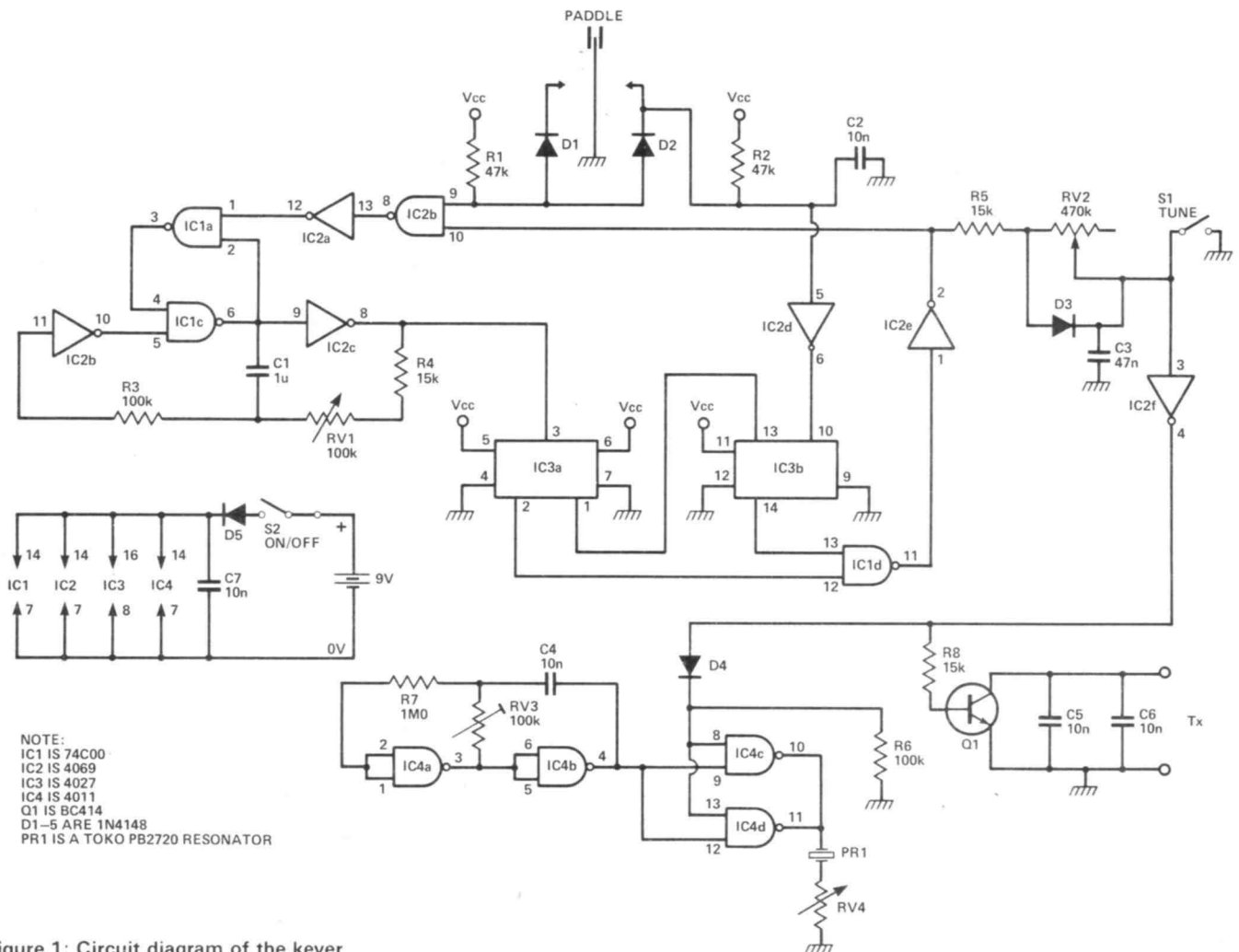

Figure 1: Circuit diagram of the keyer

9V battery; although any voltage between 3 and 15V may be used. Control over the speed, from 6 to 50 WPM, together with weighting, a switched 'tune' facility (for the transmitter) and a level control for the audio monitor are all provided.

Construction

The keyer circuitry, together with the paddle, is built on a single sided PCB (Fig. 2). If you want to build either separately, then the PCB can be divided where shown.

The paddle is constructed from fibreglass laminate which lends itself to easy cutting and soldering. Contact is made via 6BA bolts, allowing an adjustable gap with the lever (see Fig. 5). Since a high impedance circuit is being keyed, there is no need for precious metal contacts.

In order to avoid the need for a double sided main PCB, the paddle is built on the

track side. The board is mounted 'upside down' in the cabinet, with wired connections made direct to pads on the track side. The user-end of the paddle is made from two pieces of Perspex, or similar material, filed to a suitable shape and mounted with adhesive.

Assemble the components - use IC sockets - leaving the resonator until the paddle is finished. Check that all the semiconductors are inserted correctly.

When the assembly is finished, check for solder bridges - especially between the IC pads - then temporarily connect the controls, battery, and the resonator (directly from its pad to earth, for the present). Using a piece of wire, with one end connected to earth, check that the keyer operates correctly by touching the dot and dash pads on the main PCB. Also check the speed and weighting controls.

Current consumption should be around

400uA, in the quiescent state, and 2mA when keying. Any abnormal departures from these figures should be investigated (look for short circuits first). If there is no output, check the circuit with a scope or multimeter - there should be a very low continuous output from the resonator, in the quiescent state.

The Paddle

The paddle can now be constructed. Prepare the pieces carefully. If you can, plate these to prevent corrosion, or use a PCB lacquer. Remember to make sure that the individual pieces of laminate are cut squarely.

Solder the back plate "A" to the main PCB, as indicated in Fig. 3 (the drawing is shown with the paddle on the component side for clarity, but it is *actually* assembled on the track side), ensuring that it is at right

Circuit Description

The circuit for the complete keyer is shown in Fig. 1. This is a very reliable configuration with no adjustments needed.

The clock, consisting of IC2b, IC1c C1/R3/R4 and RV1, is a stable RC oscillator. Under quiescent conditions, pin 9 of IC1b is taken high by R1, with both flip-flops at reset giving a logic 1 on pin 10 of IC1b. IC1a and IC1c control the RC oscillator, which is inhibited by a low on pin 4 of IC1c. As soon as either of the paddle contacts are made, pin 4 of IC1c will go high and allow the oscillator to run. The first half cycle of the oscillator places a low on pin 2 of IC1a, allowing the RC oscillator to continue when the paddle is released.

This first clock pulse also clocks IC3a to the set state. Assuming a dash was sent first, IC2d enables the J input of IC3b, allowing it to be triggered by the rising edge of IC3a's output. If the dot contact is closed, IC3b remains in the reset state due to the low on its J input from R2/IC2d.

The outputs of the 2 flip-flops are summed by IC1d and drive the keying transistor via the weighting network R5, D3, C3 & RV2. When the paddle is being operated, the RC oscillator is enabled by IC1b/IC2a. As soon as IC3a resets, the dot or dash is terminated and the clock signal, being high, will maintain oscillation for another half clock period. Premature triggering of IC1a/IC1c is prevented here, by a logic 0 on pin 5 of IC1c. After another half clock cycle, pin 5 of IC1c goes high and re-enables signals from the paddle.

A simple RC oscillator, consisting of IC4a and b provides the sidetone monitor source; with the pitch adjustable via a preset. IC4c and d are paralleled to drive a piezo-ceramic resonator, with the output controlled by the logic level on pins 8 and 13. The volume of the device can be set by using RV4 and reverse voltage protection is given by D5.

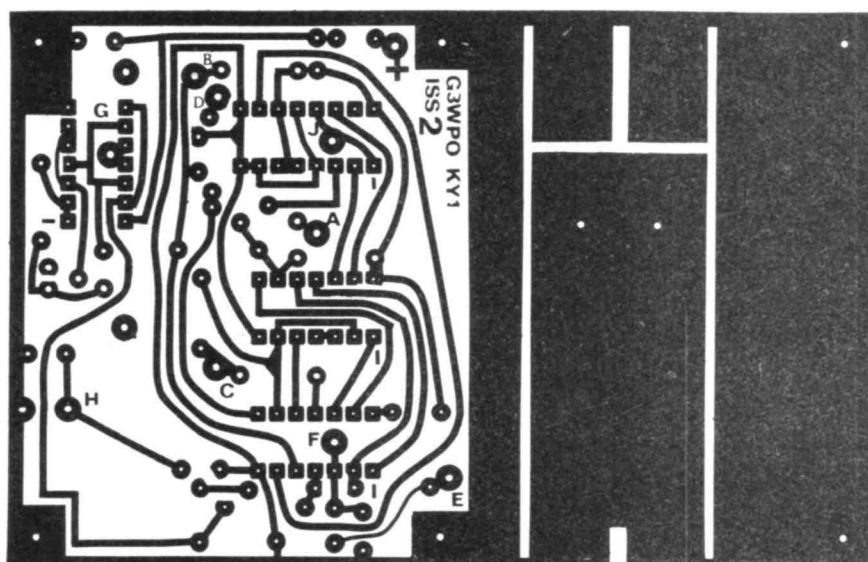

Figure 2: Foil pattern for the single sided board

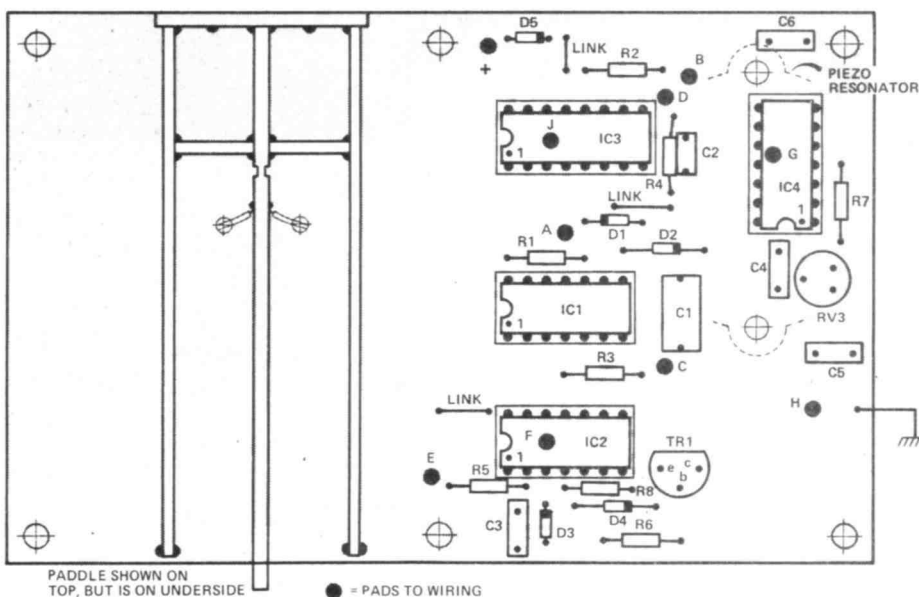

Figure 3: Component placing

CMOS KEYS

angles. Then, solder the paddle into place after tinning the area which will "contact" the bolts.

Next, solder on the two small spacers, "C" & "D". Prepare the side pieces "E" & "F" by screwing a 6BA nut onto a 1" Bolt. Put the bolt through the hole in the side piece (on the correct side) and screw another nut on from the other side. Now solder the side pieces into place, with the nuts towards the front and top of the paddle. Finish by inserting the bolts, leaving a suitable space equidistant from each face of the paddle.

Prepare the paddle extension (Fig. 6) and fix into place using cyanoacrylate or epoxy resin adhesive. Make sure that the lower edge of the extensions will clear the aluminium extrusion on the case.

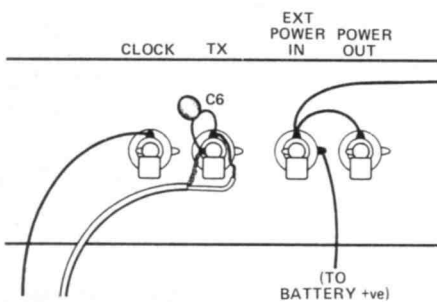

Figure 4: Wiring diagram for the back panel

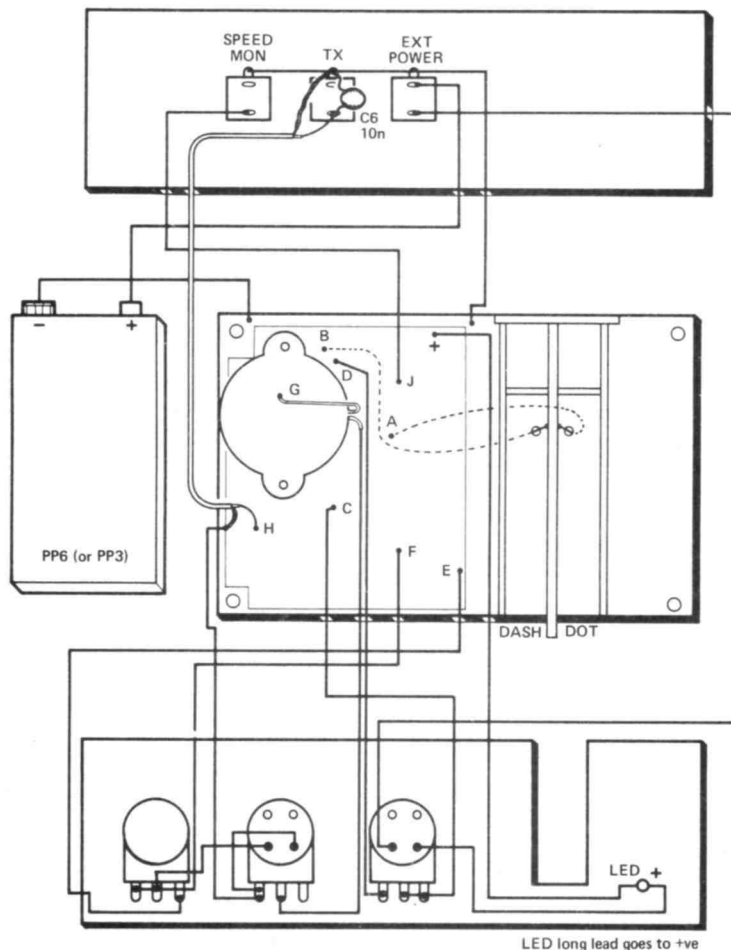

Figure 5: Wiring diagram, inside the case

PARTS LIST

Resistors

R1,2	47k
R3,6	100k
R4,5,8	15k
R7,	1M

Potentiometers

RV1	100k anti-log with switch
RV2	500k lin
RV3	100k preset 6mm
RV4	100k log with switch

Capacitors

C1	1 u polyester
C2,4,5,6,7,	10n ceramic disc
C3	47n ceramic disc

Semiconductors

IC1	74C00
IC2	4069
IC3	4027
IC4	4011
Q1	BC414(see text)
D1-D5	1N4148

Miscellaneous

PR1 Toko PB2720 resonator.
14 pin DIL sockets (3 off), 16 pin DIL socket, PP3 battery connector, 3.5mm jack sockets and (3 off), knobs (3 off), 1/2" 6BA spacers (4 off), 6BA 18mm bolts and nuts (6 off), 8BA 18mm bolts and nuts (2 off), PCB materials, plugs Perspex, Centurion case (DX1), rubber feet.

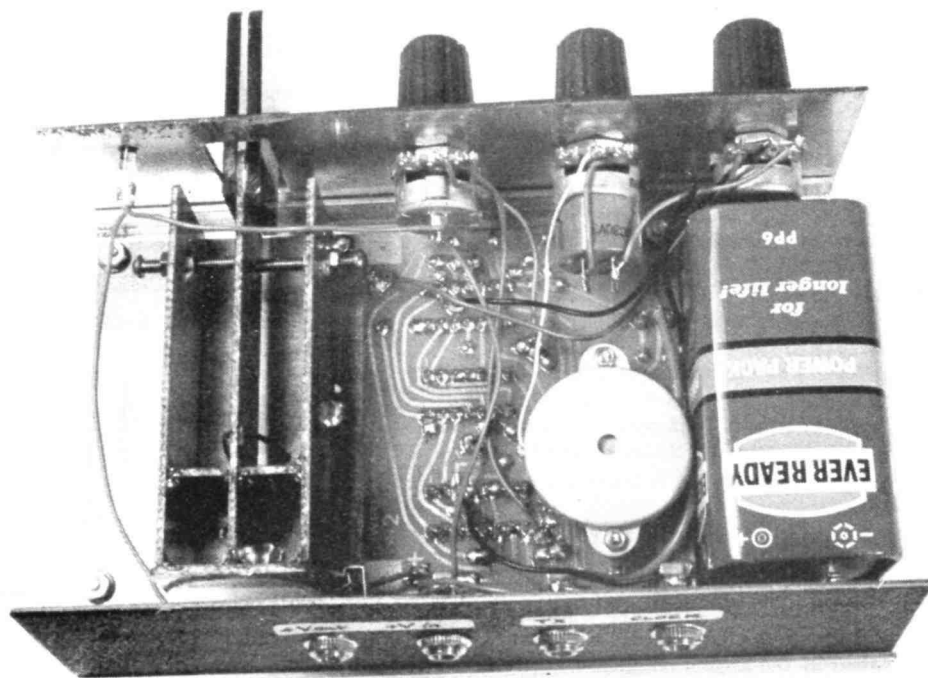

Internal view of the CMOS Keyer.

Assembly

The keyer is now ready to be put into its case. Before doing that fix the ceramic resonator to the track side of the PCB using 8BA nuts and bolts (wire the connection to pad "B" first).

Wire the unit following Fig. 5, but omit fixing the central potentiometer to the front panel until all wiring is completed (use flying leads ready for the control).

Comments

As described, the keyer will drive transmitters that have a positive keying voltage up to 40 volts and 100mA. If your rig is outside this range, then the transistor will have to be changed for a more suitable type. A reed relay could be used, though this will increase the current requirements if a battery is being used. Another alternative is to change the transmitter circuit or add a high voltage keying transistor to it.

A "tune" facility is provided, which switches the output transistors on, continuously. The value of R4 determines the maximum clock speed and can be lowered (to 10k) should you require increased speed.

If you want to accurately measure the keyer speed, the rate in words per minute = $1.2 \times \text{clock frequency (Hz)}$. The clock

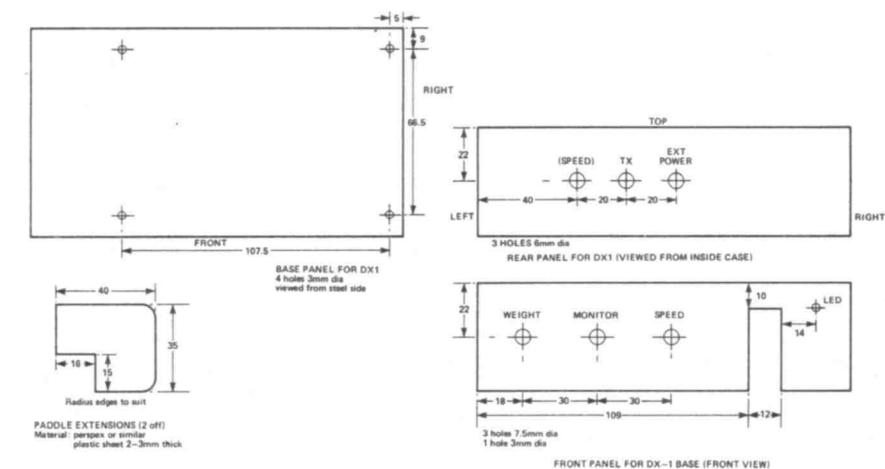
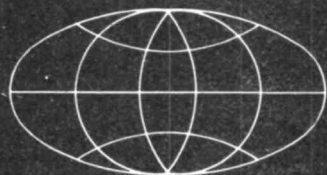

Figure 6: Dimensions for the case and paddle.

output can be obtained on pin 1 of IC3a, while holding one of the paddle contacts on continuously. The socket on the rear panel marked "speed" is for the R&EW digital speed readout module (to appear next month). This will allow you to check whether the chap at the other end can *really* copy 35 WPM.

R&EW

YOUR REACTIONS	Circle No.
Good	19
Average	20
Poor	21



Intermedial Ltd.

3, Beech Avenue, Eastcote, Ruislip, Middx. HA 4 8UG, Tel. 01 8664641



PRECISION LOCATORSET

With the accuracy of a computer program (tolerance less than .5%), this map and ruler cannot be compared with ordinary locator maps.

- Ruler can be fixed at QTH •Size 30 x 42½ inches, scale 1:3 million •Printed in 4 colours on washable plastic •Metal top and bottom strips •Approved for contests •Full directions •Dispatched in sturdy cylinder. £11.50

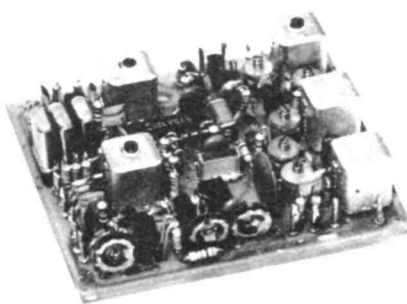

PLL TRANSCEIVE V. F. O.

Converts any surplus radio telephone into a continuously variable F.M. transceiver. Microphone is connected to unit and a stable 2 metre F.M. signal is available for driving the amplifier stages. On receive the unit produces a local oscillator signal 10.7MHz below signal frequency. •600KHz repeater shift •Suitable for other I. F.'s •Extension for digital display •Kit includes all components (exc 3 Xtals and varco) •8 pages of directions. £14.90 (directions only £0.95)

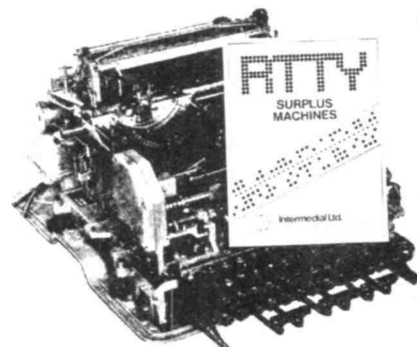

SURPLUS RTTY MACHINES

Until now there was no amateur information available on surplus RTTY machines. This book (abt. 80 pages) gives complete diagrams, data and pictures as needed for the correct connections of frequently used machines. Teletype 14, 15 and 33; Siemens T37, T100 and T10ch 15; Kleinschmidt TT-4/TG; Creed 75; Lorenz L015. £3.45

C.W.O. All prices incl. VAT, p&p (within U.K.)

Ian Campbell delves into devices based on SURFACE ACOUSTIC WAVE technology.

SAWS

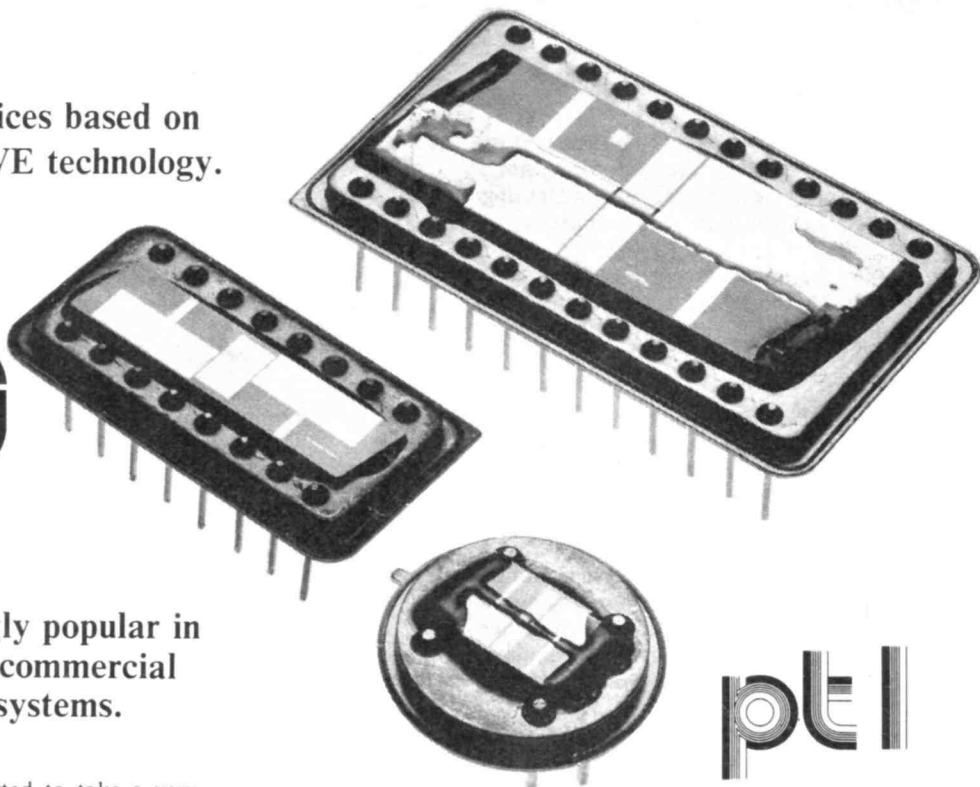

These are becoming increasingly popular in a wide variety of consumer, commercial and military electronic systems.

A NUMBER OF MANUFACTURERS started to take a very serious interest in developing devices based on Surface Acoustic Waves (SAWS) way back in the late 1960s. By 1976 the first IF filters for FM receivers, working on the SAW principle, were seen in the market place. Now SAW devices have widened their field of applications into oscillators and a variety of delay lines as well as a multitude of filters of different types. These devices may be found in satellite and spread - spectrum communications, radar, TV, digital data systems, frequency synthesis, missile applications, and microscan receivers.

Basic Principles

The SAW phenomenon is brought about by the interaction of two sets of interleaved metal fingers, each connected to a bus bar, called an Interdigital Transducer (IDT) and a piezoelectric substrate. Fig. 1 shows the basic idea.

The IDT metalisation, which is usually very thin aluminium 0.5-0.005 micro-metres thick, is vapour deposited onto the polished surface of the substrate. The required pattern of the IDT, about which more will be said later, is produced by photolithographic etching in much the same way as patterns are formed on IC devices.

The piezoelectric substrate can be made from a variety of substances including lead zirconate titanate, zinc oxide thin film - see Fig. 2, lithium tantalate, quartz and lithium niobate. The later substance seems to be the most commonly used material, probably because it has a modest raw material cost, a low temperature coefficient and a high piezoelectric coupling factor.

Having described the basic structure of the producer of surface acoustic waves it might be a good idea to say exactly what these waves are and how the structure in Fig 1 makes them.

ELECTRODE FINGERS OF INTERDIGITAL TRANSDUCER

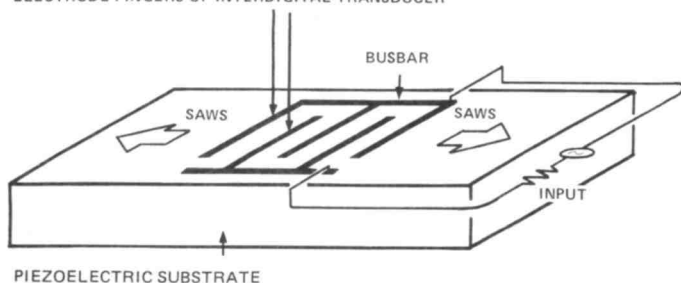

Figure 1: The interdigital transducer on its substrate.

What Saws Are

The types of SAWS which are employed in signal processing are elastic waves which travel along the plane surface of a solid and lose very little of their energy in so doing. The amplitude of the waves decays exponentially from the surface down into the bulk of the solid which implies that approximately 95% of the wave energy is contained within one wavelength of the surface. To put a figure on this would mean that at a frequency of 300MHz most of the wave energy would be within 11.5×10^{-6} metres of the surface.

It is rather interesting to note that the surface acoustic wave phenomenon was demonstrated as long ago as 1885 by Lord Rayleigh and is also the primary mode of propagation of the shocks of earthquakes.

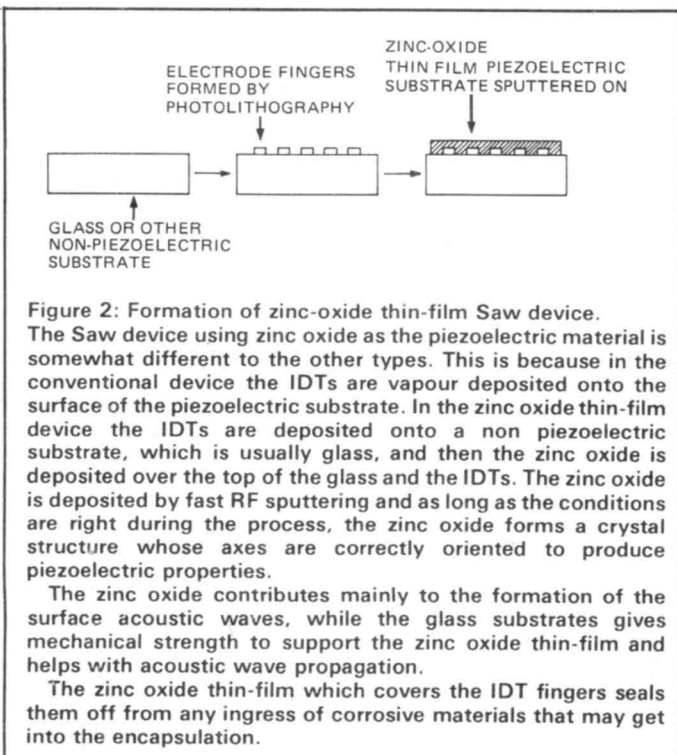

Figure 2: Formation of zinc-oxide thin-film Saw device.

The Saw device using zinc oxide as the piezoelectric material is somewhat different to the other types. This is because in the conventional device the IDTs are vapour deposited onto the surface of the piezoelectric substrate. In the zinc oxide thin-film device the IDTs are deposited onto a non piezoelectric substrate, which is usually glass, and then the zinc oxide is deposited over the top of the glass and the IDTs. The zinc oxide is deposited by fast RF sputtering and as long as the conditions are right during the process, the zinc oxide forms a crystal structure whose axes are correctly oriented to produce piezoelectric properties.

The zinc oxide contributes mainly to the formation of the surface acoustic waves, while the glass substrates gives mechanical strength to support the zinc oxide thin-film and helps with acoustic wave propagation.

The zinc oxide thin-film which covers the IDT fingers seals them off from any ingress of corrosive materials that may get into the encapsulation.

How Saws Are Made

When an oscillating signal is applied to an IDT an oscillating electric field is set up in the piezoelectric substrate below and between the fingers of the IDT. The piezoelectric material responds to this electric field by physically distorting and elastic stresses or strains, or both, are set up in it. If all the conditions are right then a surface acoustic wave is launched from the IDT as a tossed pebble makes ripples in the surface of a smooth stretch of water.

Just what these conditions are will become apparent if Fig 3 is taken into consideration. Let us say that a 100MHz signal is applied across the IDT. If the piezoelectric substrate is lithium tantalate then the propagation velocity of a surface acoustic wave through it will be approximately 3200 m/sec. The wavelength of a 100 MHz signal which has this velocity is 32 micrometres. In order to respond to a frequency of 100 MHz the IDT must have what is known as a period of 32 micrometres. This is in order that one 'cycle' of a 100 MHz acoustic wave will fit between any two fingers of the same potential. It will in addition be seen that between these two fingers will be one of opposite polarity. This causes stresses to form at points A and B which will be working in opposite directions thus forming the crest and valley of a wave. Since the electrical polarity of the fingers of the IDT changes with a frequency of 100 MHz, waves are set up in the surface of the piezoelectric substrate with each finger contributing to their production. Since the fingers and the distances between them are 8 micrometres wide they will be completely in phase only at 100 MHz.

It should be mentioned here that wherever a surface acoustic wave is propagating in a piezoelectric substrate, electric fields are formed in it. An IDT positioned in these fields will have electrical signals produced in it which correspond to these electric fields.

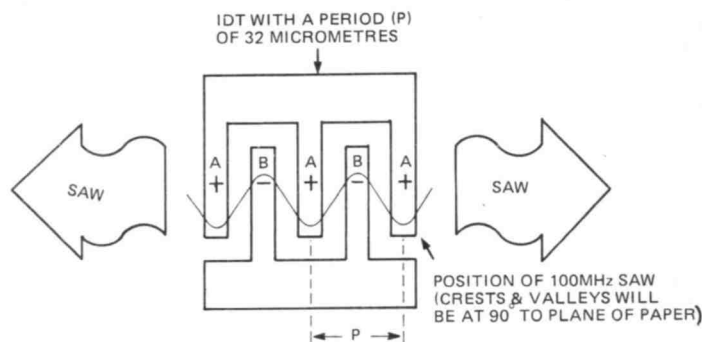

Figure 3: Showing how surface acoustic waves are produced.

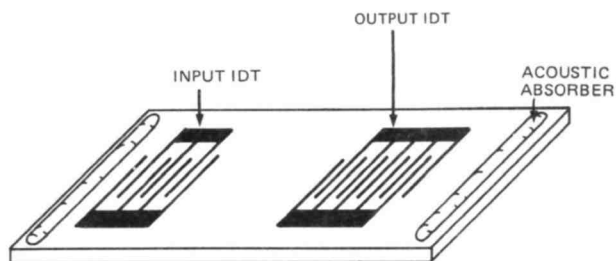

Figure 4: The SAW bandpass transversal filter.

The Frequency Limits

The maximum operating frequency of SAW devices is determined mainly by lithographic capabilities. For conventional IDTs the finger width is a quarter wavelength and with normal lithography, finger widths in the region of 0.75 μm can be made with care. This corresponds to a wavelength of 3 μm which, for an acoustic velocity of 3000 m/sec, gives a maximum frequency of 1 GHz.

Special techniques eg direct-writing electron-beam lithography, can be employed for 'specials' to make finger widths smaller and increase the upper limit.

The lower limit is governed by, amongst other things, substrate size versus cost and problems with bulk waves. This makes 10 MHz about the optimum, all things considered.

The Saw Bandpass Filter

At this stage it would be a good idea to have a look at the evolution of a useful SAW based device. Fig. 4 shows a simple form of bandpass filter. This is a transversal filter and works on the travelling wave principle (as opposed to a resonator filter which works on the standing wave principle).

A surface acoustic wave is generated, when an electrical signal is applied to the input IDT, which propagates along the surface of the substrate. The wave travelling to the left is cancelled out by an absorber on the left of the IDT, whilst the wave travelling to the right causes an electrical signal to be formed in the output IDT. The propagation velocity of a surface acoustic wave is constant irrespective of its frequency and so its wavelength must change inversely with the frequency. When the pitch or distance between each of the fingers of the output IDT is constant, maximum output takes place when the transducer's period is equal to the wavelength of the acoustic wave. Any variation in frequency of the applied signal will result in a change in wavelength and in consequence a greater or lesser degree of cancellation at the output IDT's fingers. This implies that the centre frequency of the filter is determined by the period of the output IDT.

Some Maths

For those with a mathematical turn of mind the following will be of interest. As described, the filter will have a frequency response

expressed as a $(\sin x)/x$ function as shown in Fig. 5. If the period of fingers of like polarity is λ_0 then its centre frequency $f_0 =$

$$\frac{\text{Surface Acoustic Wave propagation velocity}}{\lambda_0}$$

$$\lambda_0$$

The bandwidth (Δf) is in this case the distance between the first nulls on either side of the centre frequency, it is given by

$$\Delta f = 2f_0/N$$

where N is the number of finger pairs in the output IDT.

This means that the narrower the bandwidth the larger the number of fingers and vice versa.

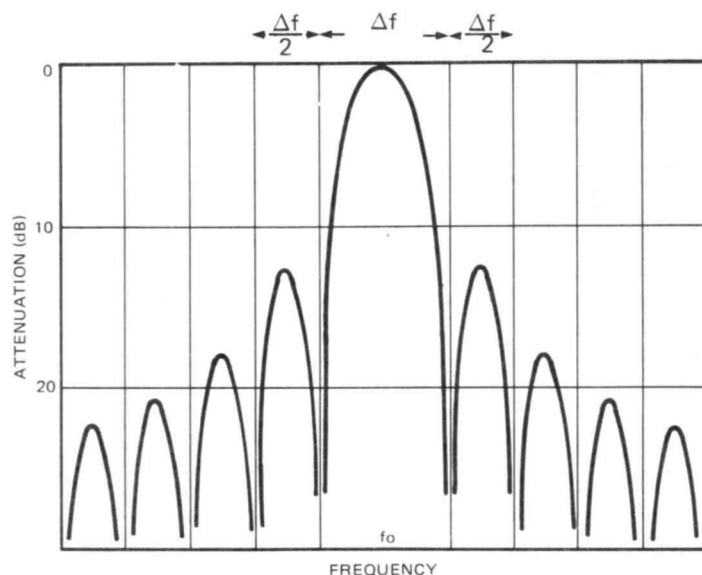

Figure 5: The frequency characteristics of a basic Interdigital Transducer.

Changing The Frequency Response

The type of frequency response shown by the simple filter, with its large number of side lobes, is not a very satisfactory state of affairs for many applications. A much more suitable response could be like the one in *Fig. 6*. So how, one might ask, can such a set of characteristics be obtained. The answer is really quite easy – change the geometry of the output IDT. A little thought about what has already been said will reveal that changing the position of a finger, relative to the others, will alter the time at which it contributes to producing an output. Changing the degree of overlap of the fingers will determine the amplitude of their contribution to the output signal. A quick zoom in onto *Fig. 7*, but watch out for eye-strain, will disclose an IDT that has been got-at in order to change its characteristics.

Making Sure It Works Properly

Now that our SAW filter has got its frequency characteristics right there are still a few odds and ends which may impair its performance. Fortunately with a little effort they can be greatly minimised.

One of these, which is potentially rather serious, is an irregularity called the Triple Transit Echo or TTE for short. This is caused when part of the surface acoustic wave travelling from the input IDT is reflected back to it by the output IDT and then returns again to the output IDT. *Fig. 8* shows a typical pulse response waveform and illustrates the amplitude and position with respect to time of the main signal, and the TTE. The complicated set-up which is typically used to do all the measurements is shown in *Fig. 9*. The TTE can be suppressed by 40 dB, however, to do this there is a trade-off. The filter must be somewhat mismatched to its terminating impedances and this results in a power loss through it. The value of the loss, for satisfactory suppression of the TTE, must exceed 18 dB.

Fig. 10 shows the way in which another problem may be reduced – Direct Breakthrough. In this case it is possible for signals to appear on the output transducer as a direct result of electrostatic or electromagnetic induction taking place between it and the input transducer. This coupling may be reduced by placing a guard ring between the input and output IDTs as illustrated.

A glance back to *Fig. 4* will reveal the solution to another problem, namely reflections from the ends of the substrate. Acoustic absorbers behind the IDTs together with bevelled edges, reduces these to an acceptable level, the bevelling steering reflections away from the IDTs. If the eyes can take it, *Fig. 7* shows

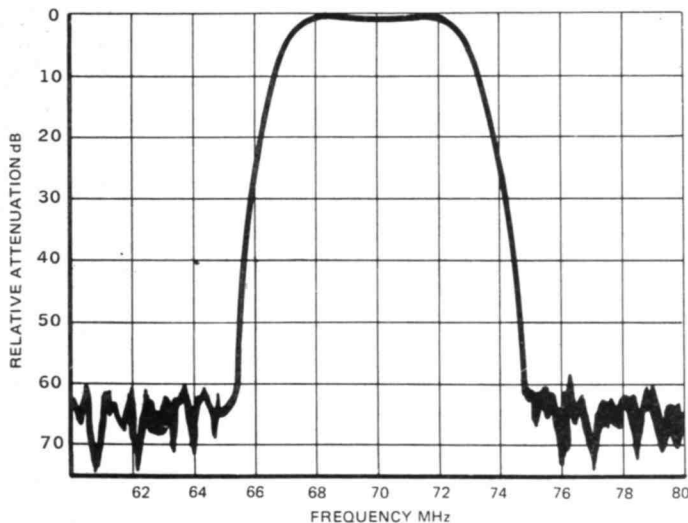

Figure 6: The frequency response of a SAW filter with modified finger geometry – the Signal Technology BP1103.

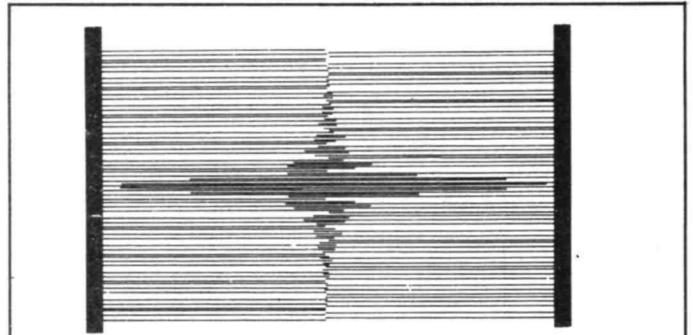

Figure 7: An interdigital transducer with modified finger geometry.

To design an IDT with a particular frequency response necessitates the performing of a Fourier transform on this frequency response which yields the impulse response. The next step is to take only the part of this transform which contains most of the signal energy followed by physically building the waveform into the IDT finger overlaps.

As a way of example, the frequency response of an IDT with a uniform finger overlap, is to a first order of approximation a sampled rectangular function. The Fourier transform of this is a $(\sin x)/x$ function. If this function is built into an IDT symmetrically about its geometrical centre then its frequency response becomes virtually rectangular.

the solution to the problem of reflections within the IDTs themselves. These are reduced by replacing some quarter wavelength wide fingers with pairs of fingers one eighth wavelength wide. This causes the signal reflected from half a finger to add destructively to the signal reflected from the other half.

Although it has been said that IDTs generate surface acoustic waves, unfortunately there is also the possibility of a bulk wave being produced. This is an acoustic wave which as its name implies travels through the mass of the substrate below the surface. It tends to produce a signal, albeit probably a small one, in the output IDT. In order to get rid of this the input and output IDTs are offset on the surface of the substrate. This would mean that any bulk wave produced by the input IDT would pass by the output IDT without affecting it. The surface wave of course would also do the same, however, it can readily be redirected by means of a coupler as shown in *Fig. 11*. The coupler consists of a uniform grid of isolated fingers between the IDTs and does not respond to bulk waves which pass it by.

The glue that sticks the SAW filter substrate to its package header also acts as an acoustic absorber, further reducing stray acoustic waves and preventing spurious responses.

The Resonator Filter

All that has been said to this point has referred to the transversal filter for the reason that most SAW filters are of this type. *Fig. 12* shows a resonator filter which is, even at first glance, quite different to the ones previously mentioned.

In this type of filter there is only one transducer which is of a simple form. It produces surface acoustic waves when a signal is applied to it. These waves are reflected back from the reflectors in such a way that instead of moving waves being created on the surface of the substrate, a series of standing waves is formed. In order to be efficient, the reflectors have to be a series of metal strips on, or grooves cut into, the substrate surface. The strips or grooves act as discontinuities on the substrate and must be half a wavelength apart to do the job. The resonant cavity formed between the reflectors and containing the IDT can be made to support several standing waves. The frequency response of the filter is a function of the design of the reflectors and the IDTs. It is interesting to note that the resonator filter has a potentially very much narrower bandwidth than a transversal filter and also that several resonators can be joined to form a multipole filter.

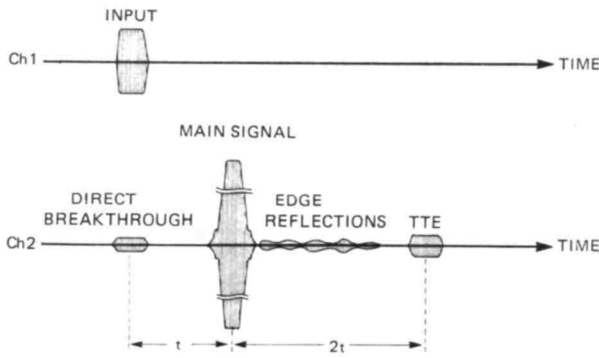

Figure 8: Typical SAWF Pulse Response Waveform.

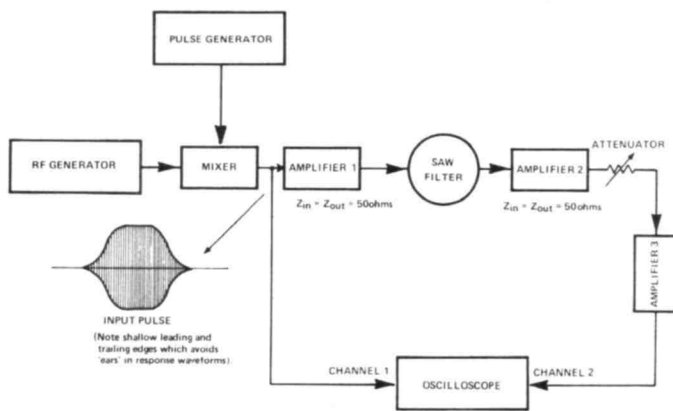

Figure 9: Block diagram of pulse response measurement system.

Delay Lines

The device shown in Fig. 4 is essentially a delay line as well as a bandpass filter. This is because the output signal is a delayed version of the input, where the delay time is a function of the distance between the IDTs and the velocity of the surface acoustic wave. The delay is typically in the order of 3 microseconds per cm length of transducer separation. Delays realisable in practical devices can range from 400 nanoseconds to 30 microseconds with a maximum delay of around 100 microseconds. The limiting factor is the size that the crystals used for the piezoelectric substrate can be grown. In fact the small size of a device capable of producing a large delay is an attractive feature of SAW delay lines. For example when using a quartz substrate a one microsecond delay is possible in a path length of only 3.2 mm.

A more complex delay line is possible than that shown in Fig. 4 where there is a series of simple IDTs following the input IDT and thus a set of delayed versions of the input signal is formulated. The respective delays will correspond to the transducer positions. These tapped delays may be externally accessible and the device find uses in electronic counter measures or connected together to form what is known as a bi-phase matched filter.

Reflective Array Compressor (RAC)

The RAC is a device which has transducers of a simple form. The surface waves which are transmitted by the input IDT travel along the substrate and are reflected across the device by means of a series of grooves cut into the substrate surface by ion milling. As will be seen from Fig. 13 these grooves will reflect the SAWs back to the output IDT. The special feature of the RAC is that the grooves are progressively wider apart the further away they are from the IDTs.

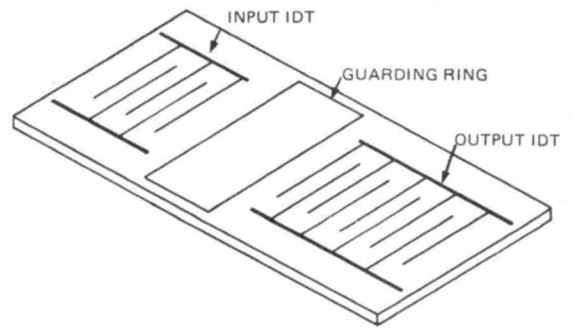

Figure 10: A SAW filter with guarding ring to reduce direct breakthrough.

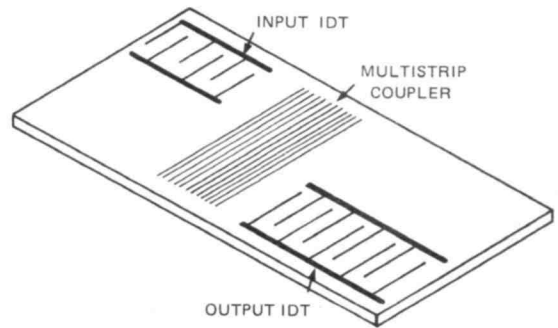

Figure 11: SAW filter with offset IDTs and multistrip coupler.

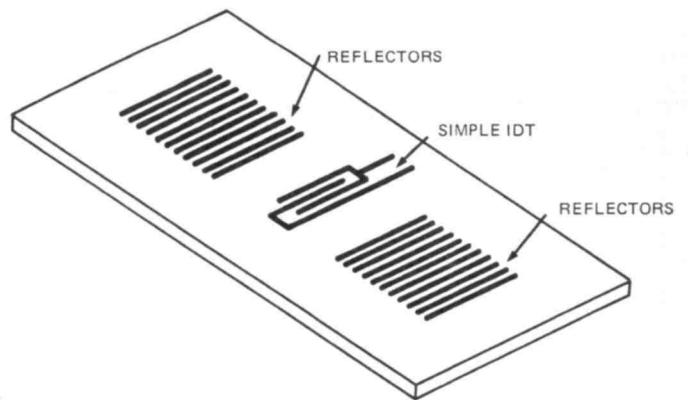

Figure 12: A resonator filter.

This structuring results in the SAWs with high frequency being reflected across first and those with low frequencies last. This means that the lower the frequency of the SAW, the further it has to travel and the more it is delayed. This introduces a form of compression, on the input signal, which is frequency dependent.

Convolver

Figure 14 shows a device which at first sight bears some resemblance to the SAW filter or delay line except that there is an extra electrode in between the IDTs. This is called the parametric electrode. The convolver works through a non-linear interaction between the two surface acoustic waves which travel towards each other from the IDTs. The non-linear effect in the substrate material produces a voltage proportional to the product of the two acoustic waveforms. The parametric electrode, which must be of sufficient length to completely overlap both incoming waveforms, integrates

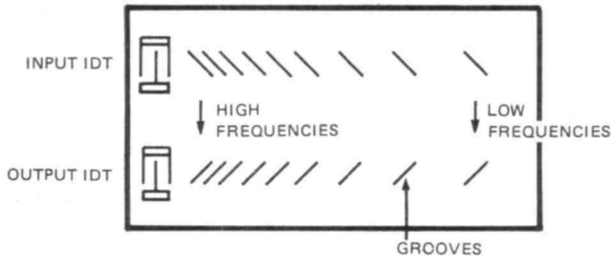

Figure 13: Reflective array compressor.

this voltage spacially and outputs a signal at twice the input frequency. This doubling of frequency is brought about because the approach speed of the two counter-propagating surface acoustic waves is twice the individual velocity of one of them.

One of the main features of the device is that it can act as a correlator. This means that if a signal of known composition is the

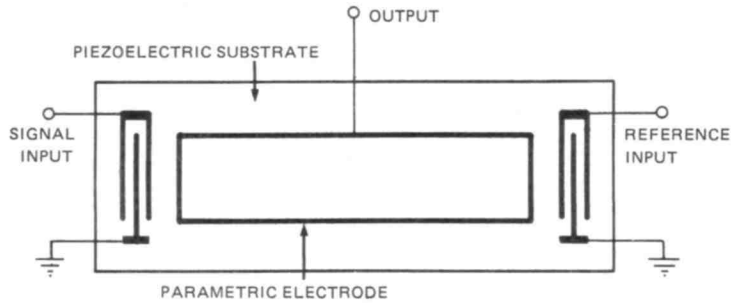

Figure 14: The acoustic convolver.

reference signal, is fed into one port and an unknown into the other port, the device produces a significant output (as long as the reference is a time reverse of the unknown signal). The device can thus find uses in IFF (Identification Friend or Foe) where a programmable code can be applied to the convolver at the same time as a coded signal from for example a radar or missile. This gives instant recognition as to whether it is an enemy or friend.

Next month Ian Campbell takes a look at some of the practical uses of SAW devices.

YOUR REACTIONS

	Good	Average	Poor
Circle No.	31	32	33

MASTER ELECTRONICS NOW!

The PRACTICAL way!

This new style course will enable anyone to have a real understanding of electronics by a modern, practical and visual method. No previous knowledge is required, no maths, and an absolute minimum of theory.

You learn the practical way in easy steps mastering all the essentials of your hobby or to start or further a career in electronics or as a self-employed servicing engineer.

All the training can be carried out in the comfort of your own home and at your own pace. A tutor is available to whom you can write personally at any time, for advice or help during your work. A Certificate is given at the end of every course.

You will do the following:

- Build a modern oscilloscope
- Recognise and handle current electronic components
- Read, draw and understand circuit diagrams
- Carry out 40 experiments on basic electronic circuits used in modern equipment
- Build and use digital electronic circuits and current solid state 'chips'
- Learn how to test and service every type of electronic device used in industry and commerce today. Servicing of radio, T.V., Hi-Fi and microprocessor/computer equipment.



New Job? New Career? New Hobby? Get into **Electronics** Now!

FREE!
COLOUR BROCHURE



POST NOW TO:-

Please send your brochure without any obligation to
NAME _____

ADDRESS _____

I am interested in:

- COURSE IN ELECTRONICS as described above
- RADIO AMATEUR LICENSE
- MICROPROCESSORS
- LOGIC COURSE

(OTHER SUBJECTS) _____

REW/1/821

BLOCK CAPS PLEASE

British National Radio & Electronics School Reading, Berks. RG1 1BR

R&EW Data Brief

A slightly different format for this Data Brief as we take a look at the design of a discrete 20W audio amplifier.

Amongst our souvenirs is a copy of the RCA Solid State Power Circuits handbook (SP-52), published way back in 1971. As far as we can tell, there are now no more available - but if you ever find one, hide it away in a safe place. The synopsis of a zero bias complementary output audio amplifier is as relevant today as it ever was back in 1971 (and the technique seems even more appropriate as you will see later), illustrating the maxim that nothing *really* changes in the business apart from the technology. Most designers of the 80's will tend to dive straight for the nearest IC when faced with the prospect of an audio amplifier for up to about 20W. Things like Hitachi's HA1370, HA1388 certainly make light work of the job - but unless you have a basic grasp of first principles to illustrate the workings of such things, it is frequently possible to end with an unstable and unreliable shambles.

Circuit description

The true complementary symmetry output circuit is, at its most basic, a complementary pair of emitter followers, with a drive circuit that endeavours to maintain operation within the linear range of the transfer characteristics (with the aid of negative feedback), but without ever actually turning them both on at the same time, and thus shorting out the power supply.

Most of the problems with 'zapping' arise when the output transistors are turning on simultaneously as a result of drive signals that exceed the rated speed of the output devices. The ideal transistor would turn on and off instantaneously - but practical transistors have finite switching speeds.

There is currently a substantial trade-off between pure switching speed and accuracy of transfer characteristics, hence the separate

classification of devices for these two jobs. Truly elegant audio output devices are few and far between, and are not simply variants on the theme of 2N3055.

So the first consideration of the audio amplifier is to prevent it being unreliable through output failure. The first thing in most such designs is thus an HF decoupling capacitor on the input to prevent the first burst of RF in the vicinity from inviting the output to short out the power supply during the overlap in their switching.

In these days of rampant RF from sources ranging from CB to taxis, it is a wise precaution to include a ferrite bead on the base of the input and predriver stages.

contd.....

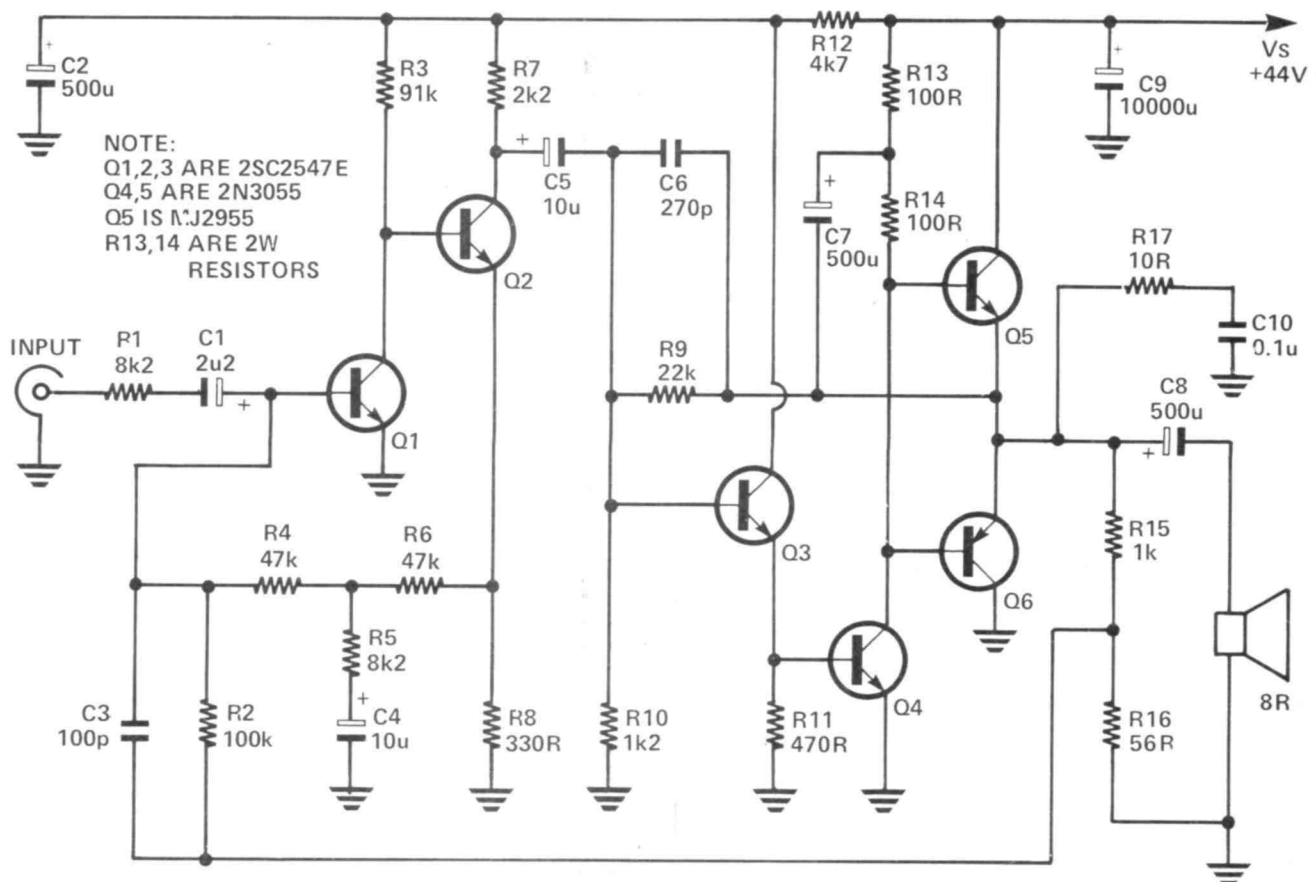

Circuit Description contd.....

Perhaps the most notable feature of this circuit is the fact that the output operates in true class B: eagle eyed readers will have observed that there can be no standing current in the output pair as long as the bases are tied together. So what about cross over distortion?

The driver operates in class A, where the quiescent current must be at least adequate to supply the base of the NPN device in the output pair. The collector current is equal to the difference between the supply voltage and the output voltage (at the emitters of Q5 & Q6), divided by R13+R14.

For correct operation of the stage, the current in R14 should be constant during the AC excursions of the output voltage (a requirement of class A), and this is achieved by the bootstrap capacitor, C7. It keeps the voltage across R14 constant by virtue of the fact that the change in voltage at the base of Q5 is essentially the same as the voltage at the junction of R13/R14 - and since Q5 is an emitter follower, the voltage at the emitter end of C7 is virtually the same as the base (with a small allowance for the V_{be} of Q5).

Thus the voltages on both sides of R14 remain essentially constant during AC transitions at the output, keeping the current constant through R14.

A big turn-off

The output transistors have to be turned hard-off during the appropriate half cycle, or the stored charge will hold the transistor on after drive has been removed, leading to operation as a poorly defined class A/B system, rather than pure class B.

When one output transistor turns on, it automatically reverse biases the other and thus sucks the stored charge from the base of its complement.

The DC feedback from the junction of R15/R16 establishes the DC voltage at the emitters of Q5 and Q6, which causes Q5 to conduct a small current. Not to be confused with A/B biasing.

The output voltage of Q5/Q6 also sets the bias point for the driver stage. AC and DC feedback proportional to the centre voltage is fed to the base of Q3. The actual DC centre voltage thus established, depends on the ratio of R9 and R10, and on the V_{be} and base current of Q3.

The DC voltage at the centre is then set by the base-emitter voltage of Q3. R9 and R11 are thus chosen to keep the base current in Q3 small with respect to the current in R7, the ratio is then set for the desired DC centre voltage, and the required AC feedback is achieved. This local feedback loop provides the output system with a high HF bandwidth, which is stabilised by keeping the bandwidth of Q1 under control by utilizing the collector base feedback of Q1, when the device is used to drive a very high collector

Performance characteristics for the 20 Watt complementary-symmetry amplifier:
(a) distortion as a function of power output;
(b) relative response as a function of frequency.

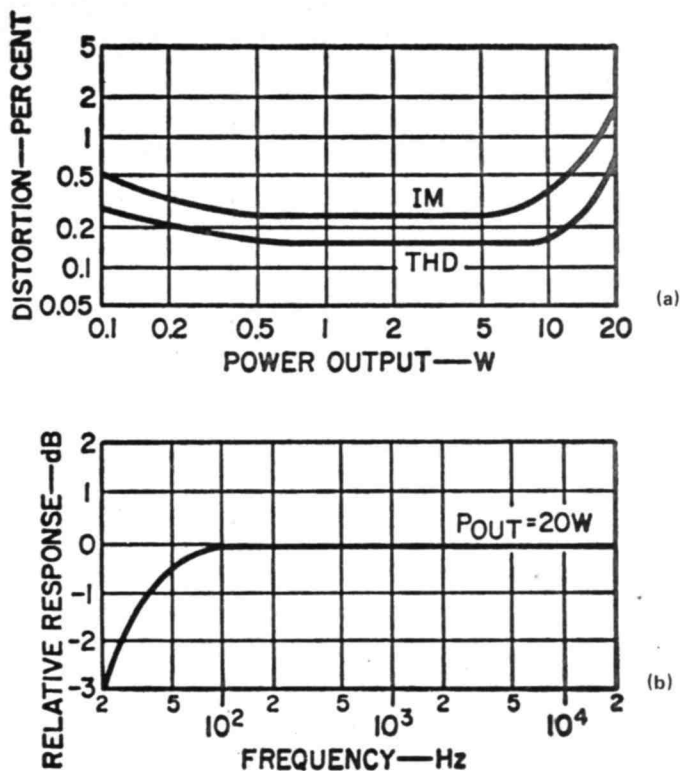

load impedance.

The LF point is established by the various coupling capacitors in the signal and feedback paths.

The predriver stages (Q1 and Q2) are a familiar direct coupled solution, with DC stability provided by the emitter/base feedback via R4, R5 & R6. The bias point is set to the middle of the stage's linear range for best dynamic performance. The overall feedback resistor, R2, also provides the route to ground via the output voltage divider.

Overall AC loop feedback is established by the ratio of R15 to R16. (Overall gain is 10 in this example). When feedback is applied to a transistor, that transistor must then be driven from a current source that isolates the feedback from preceding stages - which is simply R1 in this example.

Points to ponder

The main advantages of this system relate to the zero quiescent current conditions: reduced heatsink requirements, as the output only dissipates power when there is a signal.

Efficiency is high, there is no loss of signal in output emitter resistors - which also means that the power supply voltage is "increased" by twice the missing emitter resistance value, multiplied by the output current.

The output level of this system is only given as 20W, and above this, class A/B is/was the preferred technique - although this may be a historical throwback to the days of relatively slow high power transistors that couldn't quite cope with the exacting requirements of this approach. It would be interesting to revisit the concept with some modern superfast silicon devices, like Hitachi 2SB753 and 2SD723, to see if the improved technology has given the zero bias class B amplifier a new lease of life at high power levels. We hope that either R&EW or one of our readers will be reporting shortly.

Distortion with this type of circuit was quoted (with 1971 devices) as being below 0.5% THD, and 1% IMD. It would certainly seem from the principle of operation that IMD is going to be the major consideration: but one that may be enhanced dramatically by modern devices. We can't wait to see.

Circuit Description	Power Output (W) (8-ohm load)			Hum and Noise (dB) (Below continuous P _{OUT})		Sensitivity (mV) (For continuous P _{OUT})	Input Resistance (kΩ)	10 dB below continuous P _{OUT}
	Continuous (1% THD, unregulated supply)	Music (5% THD, regulated supply)	Dynamic (1% THD, regulated supply)	Input Shorted	Input Open			IMD (%) (60 Hz and 7 kHz, 4:1)
20-W	20	30	26	82.3	82.3	100	8.2	0.25

Typical performance data for 20 Watt complementary-symmetry circuit.

REW TEL

DIRECTORY

Roland Perry, REWTEL's Editor, has compiled a list of popular, common and 'interesting' keywords

REWTEL is still operating on Brentwood 230959 outside office hours. Our number has changed a few times, and has been subject to a distressing number of misprints (we always said ink and paper had its drawbacks), but we hope the number above will stay with us for some time now.

All keywords are now acceptable in lower case as well as UPPER CASE and long unsuccessful searches are prompted occasionally to avoid wasting telephone time. Searches take place by selecting the keyword with the least number of occurrences in the database and then checking if all the other keywords appear on any page so indicated. A "Search Unsuccessful" indicates that the specified combination does not appear anywhere on REWTEL.

In response to numerous requests we are publishing below a list of keywords. Because every word on a REWTEL page is used as a keyword a very large number of titles can be accessed by using either a very "popular" keyword (UPDATE, BULLETIN, COMPUTER, ELECTRONICS etc) or a "common" keyword (THE, AND, FOR, WITH etc). We have also selected a few interesting looking keywords which demonstrate the scope of the vocabulary we are now developing on REWTEL.

Next month we'll have details of a new REWTEL number which will be operating 24hrs a day.

"Common" keywords:

THIS
HIGH
BOTH
THAT
THE
HAS
FOR
TEL
WITH
USE
TIME
LOW
INTO
ALL
FROM
UNIT
CAN
YOU
ONE
ALSO
AND
WILL
THEN
OTHER
FULL
ANY
USING
ARE
NEW
ABLE
ALLOW
EACH
HAVE
USED
USER

"Popular" Keywords:

PAPERBACK
SIGNAL
BOOK
DIGITAL
SOCKET
BOARD
INTEL
CIRCUIT
DESIGN
RADIO
CHIP
ESSEX
MEMORY
DATA
WRE
RAM
MODEL
DEGC
CONTROL
MODULE
PLASTIC
INSTRUMENT
BULLETIN
FEATURE
LONDON
SOFTWARE
MOTOROLA
PROGRAM
INFORMATION
DISPLAY
NATIONAL
TERMINAL
PRODUCT
FUNCTION
UPDATE
COMMUNICATION
STANDARD
EQUIPMENT

INTERFACE
CHARACTER
PACKAGE
KEYBOARD
COMPUTER
MICROPROCESSOR
MICROCOMPUTER
HARDWARE
TEMPERATURE
COMPONENT
ELECTRONIC
APPLICATION

"Interesting" Keywords.

MICROINSTRUCTION
WEATHERWATCH
REFLECTOMETER
SKELMERSDALE
OPTOCOUPLER
SPECMANSHIP
TELEPROMPTER
PHOTOTYPESETTING
ELECTROSENSITIVE
PNEUMATICALLY
CRYPTOGRAPHIC
DESERIALISATION
FEATUREPHONE
DEMINERALISED
REVERBERATION
POLYETHYLENE
HYPERVAPOTRON
MITSUBISHI
PIEZORESISTANCE
ELECTROCARDIOGRAM
POLYPROPYLENE
BIOMEDICAL
IMMERSIBLE
SILICONISED
SPOTLIGHTING
BIFURCATED

MILLENIUM
THYRISTOR
LOUISVILLE
AUTOMOBILE
PHOTOTRIAC
MICROFICHE
KRIMPJOINT
HELICOPTER
INHOMOGENITIES
AGRICULTURE
BLACKHEATH
FLUORESCENT
MULTIEMULATION
TOWERBLOCK
SWITZERLAND
COMBINATIONAL
SERPENTINE
TABERNACLE
OBSOLESCENCE
FLUORINATED
REWBICHRON
PHOTOLITHOGRAPHY
NETHERLAND
HYDROPHOBIC
POLYSILICON
ENCRYPTION
CINEMASCOPE
GREENHOUSE
KLOSTERWALD
WATERPROOF
PSYCHEDELIC
GIMBAL
BIMBOX
TOY
VTR
SLUG
SANTA
Z80B
ULA
BANGOR
PSION

AUDIO BRIEF

David Strange



Electronic News Gathering is a modern way of collecting, on video tape, what used to be recorded on reversal film, with separate audio. This month, we look at the ENG facilities at London Weekend Television.

VIDEO TAPE RECORDING has many advantages when it comes to gathering up-to-date news on events around the country. The picture quality is much better than film, using a well maintained video tape recorder and camera combination. The picture is steadier in the frame, colour more reliable, and noise (in the form of sparkle) and foreign matter can no longer be seen. In some cases, even third generation cassette material can be of superior quality to the best film.

Video cassette medium has the advantage of being instant – no processing involved – and, if need be, straight out of the camera and onto air. Compared to film, the video cassette is cheap. For about 10 minutes of film, one would pay around 60 and then be in for about the same amount again for processing. Cassette works out at about £10 for 20 minutes and no processing. In practice, however, the amount of tape used is kept to a minimum to ensure the shortest possible review time, when editing.

The London Weekend Television facility is brand new, including an elaborate editing suite. Much is still in the throws of construction, so that editing sessions take place cheek-by-jowl with engineers installing equipment. At the time of going to press, one editing booth is complete along with a voice-over booth and central control unit, nicknamed "Starship Enterprise". Soon, there will be a second editing booth which is ready and waiting for equipment deliveries (the layout is shown in Fig. 1)

Putting It Together

ENG is used strictly for current affairs type programmes. An ENG crew consists of two people, the camera man and sound recordist; with a lighting electrician sometimes, depending on locational requirements.

Shooting is done using the Sony 330 camera and BVU high band recorder. The camera and VCR combination require no complicated video line-up procedures. There are two tracks available for audio but audio 2 is used because audio 1 is close to the edge of the tape and prone to damage. Track one is used for sound effects or less important audio material.

Although both of the audio inputs, to the recorder, are at microphone level, a small mixer is used for audio 2, giving additional microphone inputs and a more reliable way of monitoring and controlling the sound level. Because the audio tracks are so narrow, care has to be taken in the field to obtain the maximum modulation (consistent with no distortion) in order to avoid noise becoming apparent.

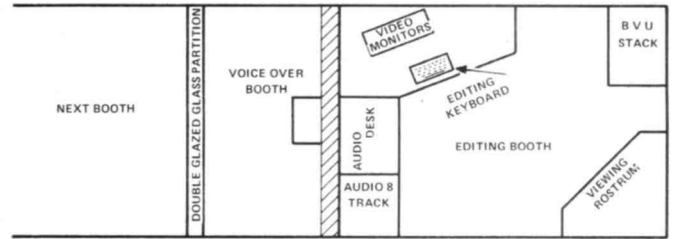
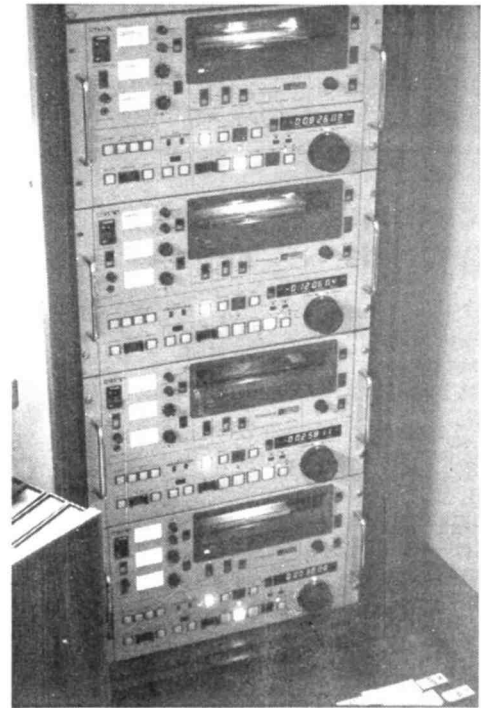
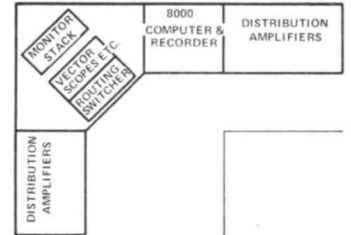

Figure 1: Layout of the central control area nicknamed 'Starship Enterprise'.



A BVU stack in the control room.

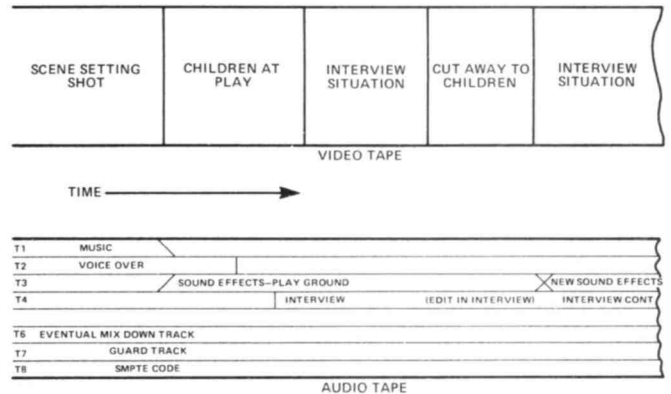

Figure 3: Link up of sound and vision on a typical 8-track tape.



Close up of a section of the 'Starship Enterprise'.

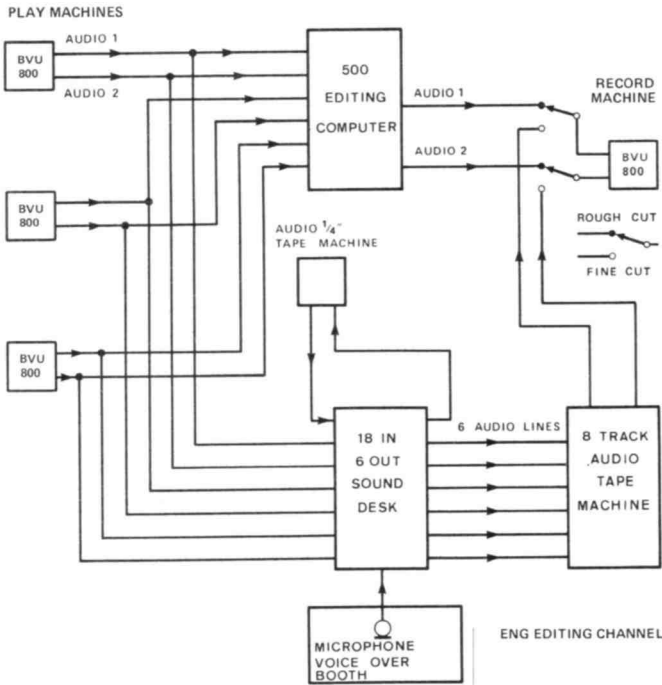

Figure 2: Diagrammatic representation of 'rough-cut' stage.



The main 8-track desk with metering and panel controls.

Consideration is given to the information that is put on a particular cassette, to make editing easier. For instance, shots to be used as a screen-setter may be put on one cassette whilst an interview is placed on a second. A talk to camera by the presenter might be put on a third cassette, and so on. This aids the later editing process if lap fades are required.

Once material has been collected on cassette from the location, it needs to be edited. First London Weekend Television may supply the programme producer with a review copy of this material, on a domestic quality cassette, for viewing in his office or at home. In any event, a rough cut is made in the editing suite by the production team. The rough cut is never put to air, but is just a copy so that aesthetic qualities can be assessed. The rough-cut stage is essentially a non-technical one and, unless some diabolical sound or vision fault is found on the original material, no engineering assistance is usually required. No sound mixing is done at this stage and the audio might sound a bit bumpy, but is good enough to give an overall impression of how the finished programme will be (Fig. 2 shows the editing suite configuration for the rough cut-stage, with the 8 track switched out of circuit).

Having made the final decisions concerning the programme content, the producer will book a fine editing session. The fine cut stage will use the facilities of the "Starship Enterprise" for vision control and editing.

Up to now, any sound on audio 2 has not even been assignable to audio 1 of the record machine (except by cross-patching). Also, sound fades have been limited to those the computer could perform directly. The imposition of effects is limited to what was recorded on location. In other words, on the rough cut, as the picture changed so did the audio.

The eight track audio tape recorder is locked to the record machine by SMPTE time code signals, so that synchronization is maintained. The time code is recorded on track-8. Track-7 has to act as a guard track between the code and the remaining six audio tracks. This means only six tracks are available for audio work.

The 8-track tape is never physically cut and any fine editing, during a session, is done on a separate 1/4" machine (Fig. 3 shows a typical 8 track assembly against vision - although time, of course, has been compressed).

The tendency, is for a particular audio engineer to have favourite tracks on to which he places various things. For instance, he may always place voice, from the booth, on track-3, effects on track-2 and so on. It is essential for the audio engineer to work closely with the production staff as the programme takes shape. There are not many industries where particular skills are recognised and respected as they are in television. The editing session is kept as non-technical as possible giving maximum leeway for the artistic and creative work of the team. However, all the time in the "Starship Enterprise", away from the editing booth, the technical quality is monitored and adjustments made to requirement.

Eventually, all the programme is edited picture-wise, but the audio is still on separate tracks of the 8-track. So, the whole programme is wound back to the head and the mix down commences. As the programme runs, the tracks are mixed down to one and any spot sound effects are added. Ideally, the sound engineer would have tapered the ends of any effects on the tape, when they were first laid down as individual tracks. So there should be no disastrous miscellaneous effects; popping up and down if a fader is accidentally left open during mix down. The mix down track is then dubbed over to the record cassette machine (to join the edited video) and it is then ready for transmission.

■ R&EW

YOUR REACTIONS

	Good	Average	Poor
Circle No.	70	71	72

ANIMATION GRAPHICS

Design by S. J. Homes.

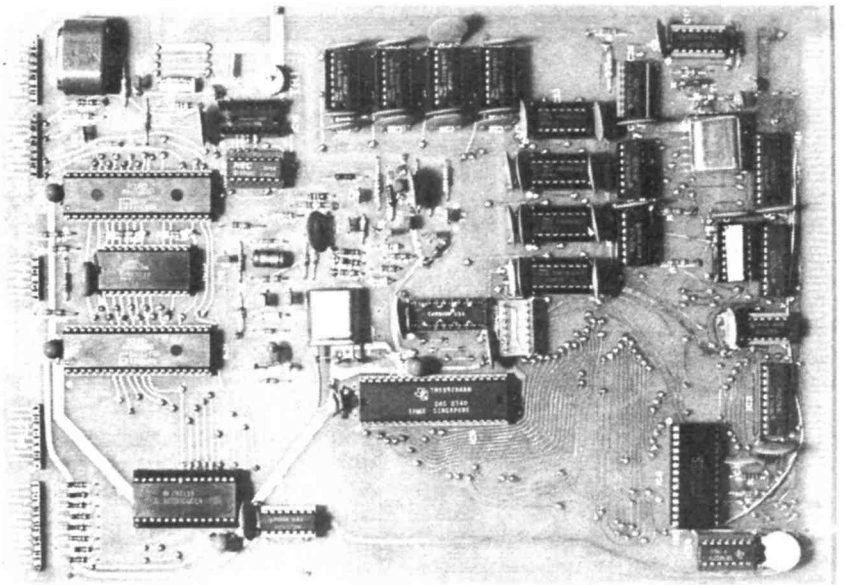

High resolution colour graphics for the Nascom – easily adapted for use with other micros.

MANY COMPUTER PROJECTS develop resembling an iceberg; you start out full of enthusiasm, only to find that nine tenths of the project is still to be worked out. Enthusiasm wanes and, like the iceberg, slowly dissolves away. This is

particularly true of early computers, where although conventional CPU boards have the usual ROM and RAM and some I/O available, when you use the facilities, many more boards are needed – extra graphics, extra I/O, joy sticks and their associated

interface circuitry. What might start out as a straightforward wiring job, turns into a major printed circuit board layout (Fig. 1) To avoid PCBs is quite a difficult business, especially since wire-wrap is both expensive and complicated and tends to

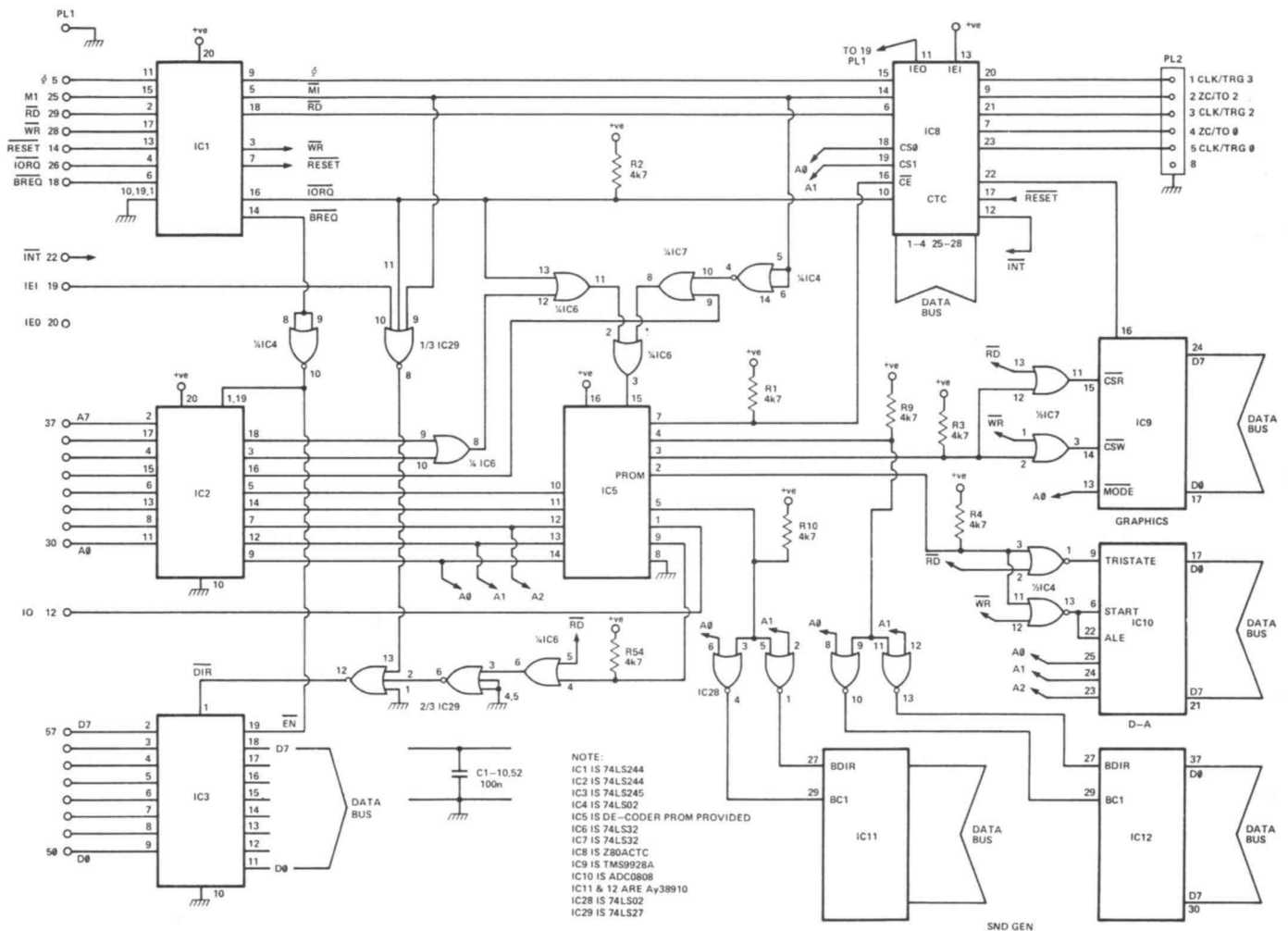

Figure 1: Circuit diagram of the I/O decoding stages.

end up in the bin after you get tired following the various signal paths. What is needed is a PCB which contains a number of useful circuits for people to conduct practical projects with their computers. Very few computers, for instance, have a real time clock, so anybody who wishes to collect and store data, cannot switch his computer from standby to receive and storage modes, at a particular time. Similarly, only a few computers have A/D converters on board, yet these are an essential component for any animation involving paddles or joysticks (Fig. 2)

For people with Nascoms, or indeed any Z80 type system, the Animation Graphics Board should provide enhanced graphics, good I/O and form the basis of a data retrieval system.

Graphics

The block graphics on the Nascom, as on the TRS80, are a bit crude by today's standards, so an update to increase the resolution and add colour is advantageous.

There are, however, two pitfalls in increasing the resolution. One is the

increase in memory requirement, which higher resolution necessitates. The other is the difficulty of moving any shape (defined by "setting" the pixals, rather than printing a ROM defined graphic shape) in a different character position on the screen.

Both these problems are overcome by using the Texas Instruments Video Display Processor (VDP) TMS9928A or TMS9929A. This family of chips interfaces directly with standard 16k Dynamic RAMS, providing all the necessary addressing and refresh signals required for the 8 RAM chips. Thus the board contains 16k bytes of screen RAM, completely separate from the user program memory - the RAM is addressed through the VDP via an auto-incrementing address in the TMS9928/9A. The VDP, like all other chips on the board, is addressed as an I/O port; hence the system's memory map is completely unaffected (Fig. 3).

Sprites

For those of us with little time to spend on complex machine code routines, a better way exists by the use of 'sprites'. The display produced by the VDP can be

visualised as a number of 'planes', one behind the other. The plane furthest away from the viewer is called the backdrop, which forms the border round the display area and also shows through an object which is coloured 'transparent'. The pattern plane is the next one in and forms the main display information for any picture. The resolution is 256 x 192 pixals, but this may be mapped in a number of ways (see Graphics 1 and Graphics 2 Mode).

In front of the pattern plane are 32 sprite planes. These are 32 planes, one in front of the other, on which reside up to 32 sprites. Each sprite is defined in the video RAM as 8 or 32 bytes of information, corresponding with its shape. A '1' in a bit position corresponds to a pixal set for the designated sprite colour on its plane; a zero is transparent.

The position of the sprite on the screen is defined by two bytes in a "sprite attribute table". To change the position of the sprite on the screen, the X, Y bytes are re-written in the video RAM. Hardware in the VDP re-addresses the sprite readout so it changes position (Table 1).

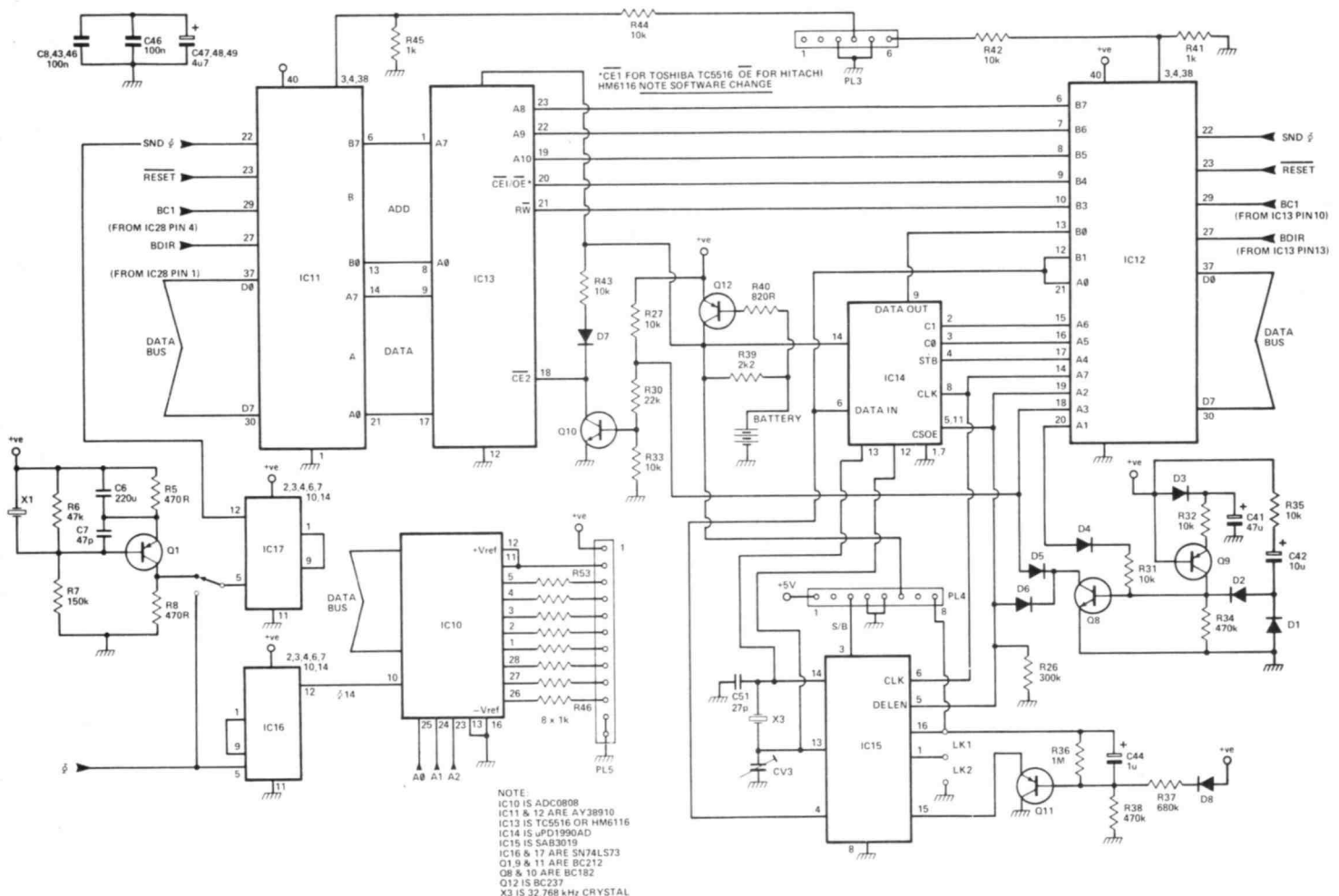

Figure 2: The A/D converters, sound, RAM and clock circuitry.

I/O PORT ALLOCATION			
0-7	NASCOM I/O DECODED FOR MAIN BOARD		
8-15	8 ANALOGUE CHANNELS FOR A TO D -WRITE TO START CONVERSION -READ TO READ VALUE		
16	}	GRAPHICS CHIP -16 READS AND WRITES DATA TO ANF FROM VIDEO RAM AFTER ADDRESS SET UP (SEE MANUAL)	
17			
18	}	READ IC12	SOUND GENERATOR IC12
19		SPARE	
20		WRITE ADDRESS TO IC12	
21		WRITE DATA TO PREVIOUSLY ADDRESSED REGISTER	
22	}	READ IC11	SOUND GENERATOR IC11
23		SPARE	
24		WRITE ADDRESS TO IC11	
25		WRITE DATA TO PREVIOUSLY ADDRESSED REGISTER	
26	}	CTC (SEE CTC DATA SHEET BUT NOTE)	
27			
28			
29			

I/O PORT No.	CS0	CS1
26	0	1
27	1	1
28	0	0
29	0	1

Table 1: Sprite attribute entries.

The sprites are ordered: the highest is nearest to the viewer, whilst the lowest order sprite is adjacent to the pattern plane. If a higher order sprite eclipses a lower order one, the hardware inside the VDP ensures the pixels of the higher order sprite take preference over those of the lower order. Hence, a 3D effect is produced with objects alternately moving behind one another. Animations are created with relatively little effort, since once the objects are defined, their positions on the screen are chosen by two bytes' X and Y co-ordinates. Altering the order of the particular sprite changes the objects relative distance from the viewer. Looking at the front cover of the magazine, the helicopter will move either behind or in front of the clouds, dependent upon the relative orders of the sprites chosen for the helicopter and clouds. In the video RAM the user creates a table of shapes and then allocates that shape to a sprite (or sprites) by: a single byte of information associated with it, X and Y co-ordinates, a pattern number (a pointer to the particular pattern to be displayed) and a byte to define colours in that pattern. To change the shape of a sprite, one simply re-defines the pointer in the attribute table. Hence the rotor blades of the helicopter can be made to rotate by defining a number of rotors in the video RAM and altering the pointer associated with the appropriate sprite.

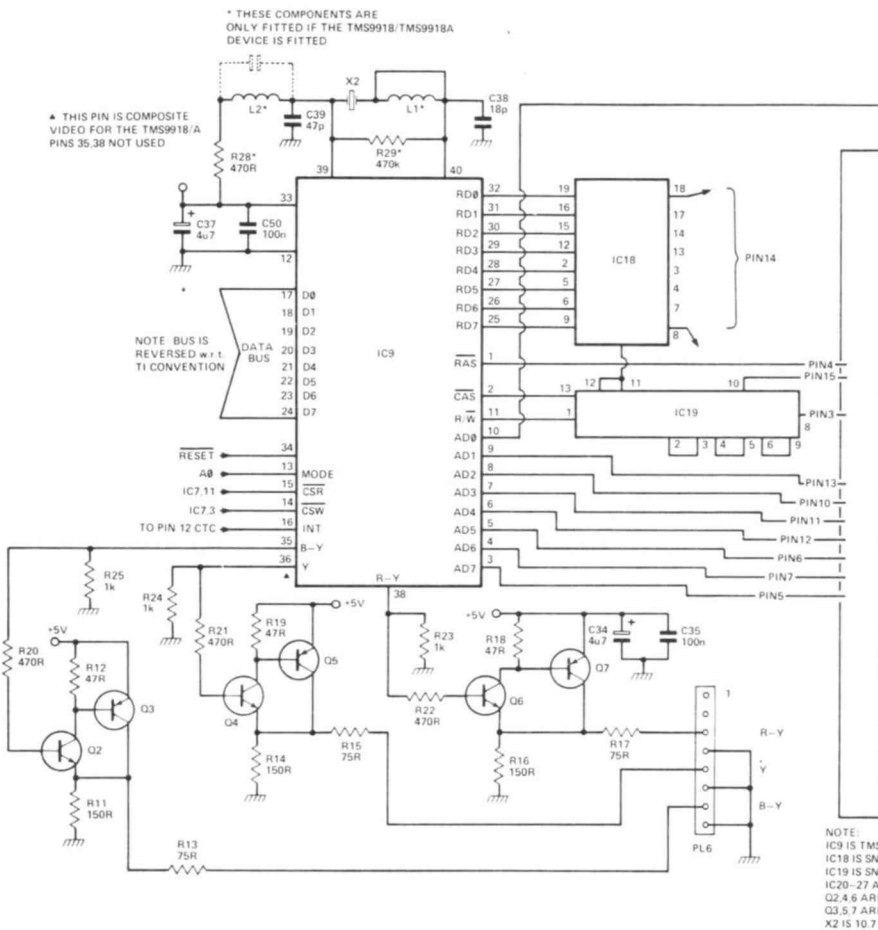

Figure 3: Graphics generation and interfaces.

Every time one byte in the video RAM changes, the rotor blade will take on a new shape and the effect is a helicopter with rotating blade. Of course, as the helicopter moves, the rotor blade must follow it and so movement is induced by altering the X and Y co-ordinate bytes, as well as the pattern pointer byte in the sprite attribute table. Should any two sprites collide ie, any of their pixals cross, a sprite coincidence flag is set (in the VDP's status register) to tell if two objects touch. Since extra memory fetch operations are needed to display sprites, the number of sprites per TV line is limited to four. If a fifth sprite moves on to the same line as four other sprites, a 'fifth sprite flag' is set and its number recorded in the VDP's status register. All sprites may be magnified 2:1 by setting the magnification bit in the VDP register to 1. If this is done, every pixal in the sprite becomes a 2×2 block of pixals, hence the sprite sizes jump from 8×8 to 16×16 or 16×16 to 32×32 pixals.

The basic resolution of the pattern plane is 256×192 pixals, normally allocated as 24 lines of 32 pattern positions (each pattern is 8×8 pixals). This would correspond to a text display of 32 characters \times 24 rows. Normally, textual characters are held in the video RAM and called onto the screen by reference to a single byte in the pattern name table (Fig. 4).

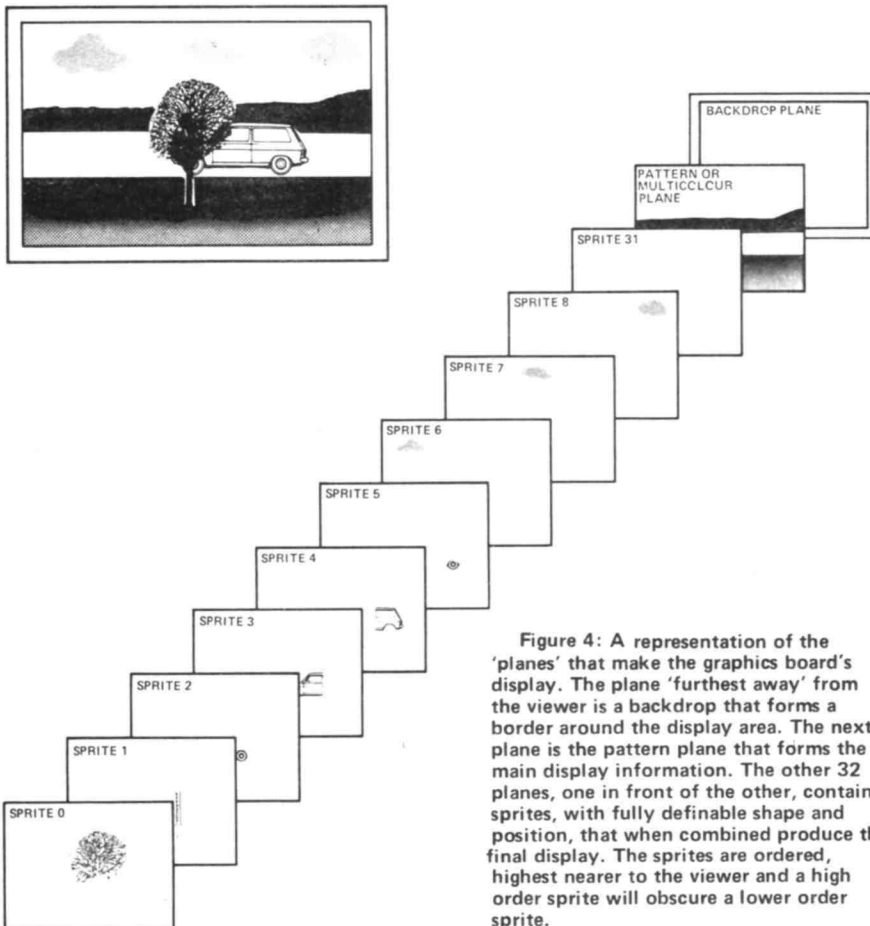

Figure 4: A representation of the 'planes' that make the graphics board's display. The plane 'furthest away' from the viewer is a backdrop that forms a border around the display area. The next plane is the pattern plane that forms the main display information. The other 32 planes, one in front of the other, contain sprites, with fully definable shape and position, that when combined produce the final display. The sprites are ordered, highest nearer to the viewer and a high order sprite will obscure a lower order sprite.

Graphics 1 Mode

In this mode it is possible to fill the screen with information (on the pattern plane) and utilise very little memory. Imagine you wish to fill the screen with the letter 'A' in every position. All you would need is a video RAM generator table with 8 bytes of information corresponding to the pixals of the letter 'A'. Also, a single byte in each of the pattern name table allocations in the video RAM; in this case, in each of 32×24 bytes. If a unique character were to be displayed in every position on the screen, then the video RAM pattern generator table would have to be 32×24 times larger.

Graphics 1 Mode allows you 256 unique characters in each of the pattern positions. This is achieved by loading the pattern name table with a byte of information which names the pattern to go into that particular character position on the screen.

When the raster starts at the top left hand corner of the screen in the display area, the VDP goes to the pattern name table and looks at the byte which points to the pattern to be displayed in the first character position (this is basically indirect addressing). This byte points to a pattern in the pattern generator table, which is another section of the video RAM containing the characters or patterns to be

displayed. This particular pattern is then fetched and displayed in the first character position on the screen (an example would be if you see a completely blank screen – the pattern name table would then contain 768 bytes which are the same and that byte would be a pointer to a pattern, defined in the pattern generator table as all zeros).

Now, it can be seen that for many animations the background, of say a game, would comprise of many identical patterns eg, areas of one colour (other than the edges) which are built up of solid blocks of the same colour. The net effect of this is that the amount of video RAM needed to define a screen full of information can often be quite small. What is more, the start of the pattern name table, pattern generator table and all the other tables which the VDP uses, are user defined by loading into the VDP internal registers vectors pointing to the start of each table. These are the master pointers which determine the start of the tables in the video RAM, where the controller will go to look for information to display on the screen. Providing there is enough video RAM available (it will certainly be available in Graphics 1 Mode), it is possible to define a number of pages or backgrounds of information, only one of which will be displayed on the screen at any one time. Since video RAM access is completely asynchronous with the display of information on the screen, when an alternative page has been assembled all that is required is to change two values in the VDP register – one on the pattern name table and one on the pattern generator table. This two byte change will cause the controller chip to go to a different section of the video RAM for its display information – a complete picture will be presented without having to see one picture disassembled and a new one built up (Fig. 5).

The colour of the pixals is determined by the entries in the colour name table. In Graphics 1 Mode it is possible to specify the colour of the 1's and the 0's in any of the 8×8 pattern positions (any one of 32×24 patterns). Just as all the other tables are under software control, a number of colour name tables can be set up and switched by changing a value in the graphics controller register.

Graphics 2 Mode

Every character position on the screen has the capacity to be a unique pattern. The pattern generator table is therefore three times longer than in Graphics 1 Mode ie, $32 \times 24 \times 8$ bytes (the colour resolution is also enhanced in this mode). Rather than just being able to specify the colour of the 0's and 1's in each 8×8 pixal pattern position, every line of each pattern can be set with the colour of the 0's and the colour of the 1's chosen independently.

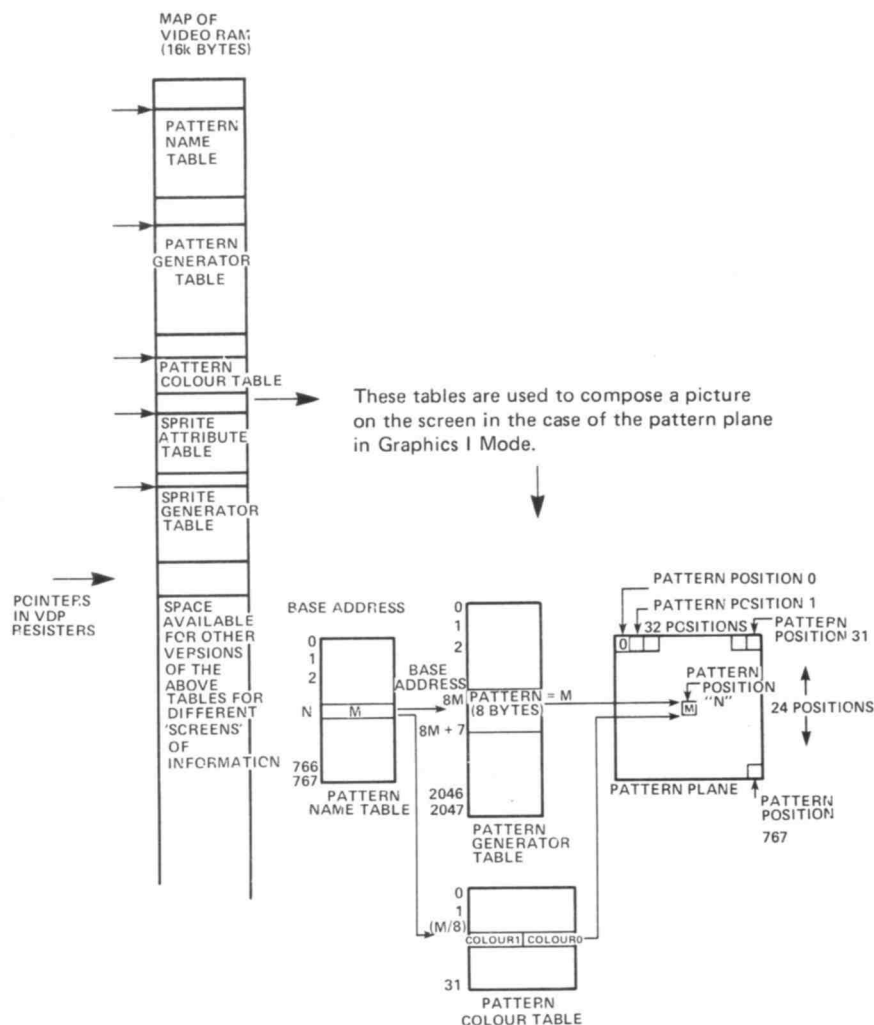

Figure 5: Composing a picture using the picture plane in Graphics 1 Mode.

Of course, this mode uses more memory for both pixal information and colour information; a total of 12,288 bytes used if every possible pattern and colour combination is utilised. This still gives plenty of room for defining sprite shapes in the 4,096 bytes left over and a complex pattern background can still be over-laid with sprites in the usual way. The pixal plot of the "raindrop" shown on the front cover was obtained in Graphics 2 Mode by turning the screen memory into a conventional memory mapped display - namely, defining all possible patterns so that there is a 1:1 correspondence between every pixal on the screen - and an appropriate bit in one of the video RAM locations.

Text Mode

If just text is to be displayed, it is more convenient to reduce the number of pixals per pattern to 7 and display 40 patterns across the screen rather than 32. In this way the patterns can be described as a 5×7 character set allowing for a 40×24 screen display of text. In this mode, however, only two colours are allowed, one for the text background and the other for the text

colour (sprites are not allowed in this mode). Where text and patterns are connected together, say for describing axes of graphs, the letters would be called up as patterns in the normal way. So it, is only when the maximum characters per line are needed that the text mode would be used.

Multi-Colour Mode

The original family of VDP's do not have the Graphics 2 Mode, with a consequent reduction in colour resolution - two separate colours per 8×8 pixal block.

These can be improved by using the Multi-Colour Mode which allows an unrestricted use of colours in any 4×4 block of pixals (any one character position ie, 8×8 pixals is divided into four quadrants, of 4×4 pixals and set to any colour). This means that the whole display area of the pattern plane is an unrestricted 64×48 colour square display. This is more memory efficient than the Graphics 2 Mode but, of course, does not have the Graphics 2 definition of 256×192 pixals.

Referring to the Graphics section circuit, it can be seen that pins 35,36 and 38 provide the B-Y, Y and R-Y signals respectively. If

only a monochrome monitor is available, then the Y signal alone will provide the display. Mixing the R-Y, B-Y and Y signals gives RGB for a colour monitor, or the R-Y and B-Y signals can be used to feed a colour encoder to produce a composite video signal to feed into the aerial of a standard colour television set. These three outputs are emitter followed to 75 ohms before leaving the board. This, as well as allowing the coaxial feed, provides some protection for the VDP.

The VDP contains its own oscillator, at 10.7 MHz, which is used to provide all the synchronisation and memory timing signals for the display system. Circuitry is included on the board to accommodate the earlier TMS9918 chips, since the oscillator is slightly different. This chip is not recommended, however, since it provides composite video out to the NTSC system. Either the TMS9928A or 29A should be used, the difference being the 28A is 525 lines 60 Hz field whilst the 29A is 625 lines 50 Hz field. A glance at the I/O decoding reveals that the VDP IC9 is mapped as two I/O ports (16 and 17) and so register, and memory, information are transferred by writing and reading signals to these ports. The software included with the board provides procedures for setting up memory accesses to and from the video RAM and the internal VDP registers, as well as sprite print and pattern print routines.

This means that you can readily start to use the graphics system without having to go through the long, painful learning process.

An interrupt pin is provided on the VDP which, if enabled, goes low at the start of every field synchronisation period ie, every 50 or 60 times per second. This is connected to the counter timer chip and is used to trigger channel 1 of the CTC and so produce a vectored interrupt to the Z80. This can be useful for a split screen application, since the CTC can be locked to the video, timing a period down from the top of the picture and then generating a further interrupt. This is used to switch pointers inside the VDP to produce an alternative picture of the lower half of the screen.

CTC

The other channels of the CTC are brought out to a plug on the board to enable external events to be timed. Alternatively, the CTC can be programmed to count the system clock and so generate the vectored interrupts at different time intervals. This is especially useful when the sound generators are used, since different sound wave forms require the switching of generator co-efficients periodically. To do this by an interrupt driven system is much more efficient on computer time and leaves the CTC loaded using I/O ports 26, 27, 28 and 29.

REGISTER	BIT	B7	B6	B5	B4	B3	B2	B1	B0	
		0	8 BIT FINE TUNE A							
1	CHANNEL A TONE PERIOD	/				4 BIT COARSE TUNE A				
2		8 BIT FINE TUNE B								
3	CHANNEL B TONE PERIOD	/				4 BIT COARSE TUNE B				
4		8 BIT FINE TUNE C								
5	CHANNEL C TONE PERIOD	/				4 BIT COARSE TUNE C				
6		/				5 BIT PERIOD CONTROL				
7	ENABLE	IN/OUT			NOISE			TONE		
		IOB	IOA	C	B	A	C	B	A	
8	CHANNEL A AMPLITUDE	/			M	L3	L2	L1	L0	
9	CHANNEL B AMPLITUDE	/			M	L3	L2	L1	L0	
10	CHANNEL C AMPLITUDE	/			M	L3	L2	L1	L0	
11	ENVELOPE PERIOD	8 BIT FINE TUNE E								
12		8 BIT COARSE TUNE E								
13	ENVELOPE SHAPE CYCLE	/				CONT	ATT	ALT	HOLD	
14	I/O PORT A DATA STORE	8 BIT PARALLEL I/O ON PORT A								
15	I/O PORT B DATA STORE	8 BIT PARALLEL I/O PORT B								

Table 2: Register designations for the sound generator.

Sound Generators

Provision is made on the board for two sound generators; the familiar GI devices AY 8910. Each device has three internal sound generators plus a noise generator and an envelope modulator. 16 internal registers set the frequency and amplitude, together with the type of envelope wave form (triangular, saw tooth etc) on the three internal tone generators and the noise generator may be enabled on any or all of the internal sound generators. The three sound generators are mixed together on R45 and R41 and feed to PL3 via two 10k resistors. It is possible, therefore, to generate sounds which move across from one side of the room to the other, since independent control of the left and right sound generator channels is possible. Since there are a total of six independent tone generators available with the two IC's, a very large variety of sounds can be produced. The clock pulses for the sound generator are derived from the system clock via IC17. However, if you want an

independent sound generator clock, T1 provides an alternative oscillator source to the system clock. The sound generators are again considered as I/O ports but the sound generator internal registers may be conveniently accessed by simply writing the internal register address to IC11 or IC12 using I/O ports, 24 and 20 respectively. To read from that previously

addressed register, a read operation is performed on I/O port 22 (for IC11) or I/O port 18 (for IC12). Writing data to that previously addressed register is performed by writing to I/O ports 25 and 21 respectively. Comprehensive sound generator routines are provided, which give a display of the sound generator registers on the Nascom screen. An added bonus is that each chip provides 16 pins of I/O addressable through the sound generator IC and is available for communicating with the CMOS RAM and/or clock chips.

In order to include the 2k x 8 CMOS RAM chip on the board, two sound generator IC's must be installed to allow for sufficient address and data lines to the RAM. Having done this, together with soldering in the three cell rechargeable battery, a non-volatile memory system is available. Looking at the circuit, Q8,9 and 10 ensure that switching transients do not cause spurious corruption of either the CMOS memory chip or the clock chip. The CMOS memory, in conjunction with the clock, can be used for data gathering or perhaps as an electronic diary. The graphics board software provides the routines for testing and accessing the CMOS memory when the sound chips are installed (Table 3).

Real Time Clock

The real time clock can be fitted to the board, provided one sound generator (IC12) is fitted. This is necessary since either of the real time clocks (NEC or Mullard) are accessed serially via the I/O ports of IC12. A crystal, X3, provides the timing reference and the clock is held active when power is removed via the Nicad battery. If the Mullard IC is chosen, and

BYTE	BIT							
	0	1	2	3	4	5	6	7
0	VERTICAL POSITION							
1	HORIZONTAL POSITION							
2	SPRITE PATTERN NUMBER							
3					COLOUR CODE			

Table 3: Port allocation for the graphics board.

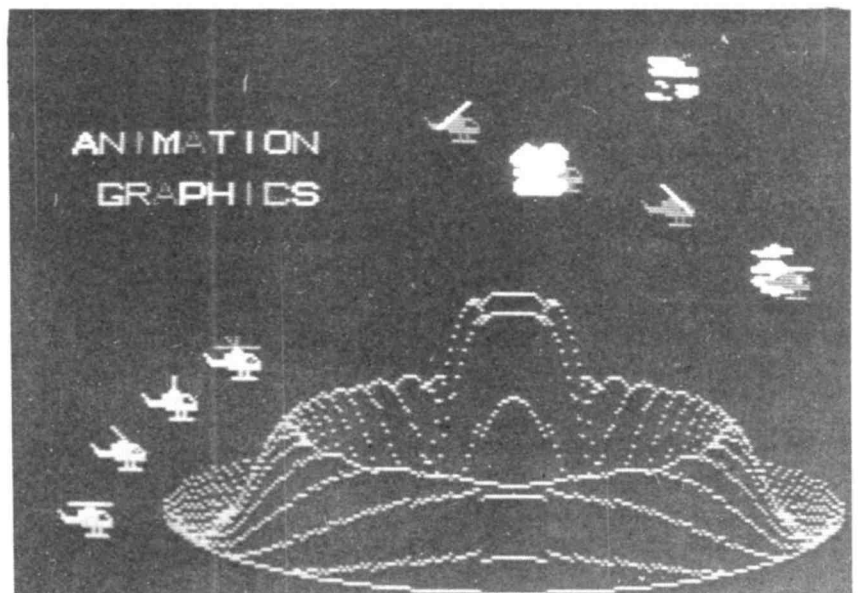

The displays used for our cover picture.

PARTS LIST

Resistors

R1-4,9,10,54	4k7
R5,8,20-22,28	470R
R6	47k
R7	150k
R11,14,16	150R
R12,18,19	47R
R13,15,17	75R
R23-25,41,45-53	1k
R26	330k
R27,31-33,35,42-44	10k
R29,34,38	470k
R30	22k
R36	1M
R37	680k
R39	2k2
R40	820R

If TMS9918/TMS9918A is used

Capacitors

C1-C5	
C8-C33	
C35,36,40	100n Disc Ceramic
C43,46,50	100n Disc Ceramic
C52	
C6	220pf Disc Ceramic
C7	47pf Disc Ceramic
C34,37,47,48,49	4u7 Tantalum
C38	18pf Disc Ceramic
C39	47pf Disc Ceramic
C41	47uf Electrolytic
C42	10uf Electrolytic
C44	1uf Electrolytic
C45	100n Polyester Low Leakage

C51 ¼pf Only used for NEC chip

Semiconductors

D1-D8	1S44 or 1S923
Q1,3,5,7,9,11	BC212
Q2,4,6,8,10	BC182
Q12	BC327
IC1,2	74LS244
IC3	74LS245
IC4,28	74LS02
IC5	
IC6,7	74LS32
IC8	Z80A CTC
IC9	TMS9928A
IC10	ADCO808
IC11,12	AY38910
IC13	TC5516(Toshiba)
or	HM6116 (Hitachi)
IC14	uPD1990AD
IC15	SAB3019
IC16,17	SN74LS73
IC18	SN74LS373
IC19	SN74LS04
IC20-27	uPD416
IC29	74LS27

Miscellaneous

X1	Sound Generator Xtal.
X2	10.7MHz Actually to be precise 10.7386 MHz but 10.7 is near enough.
X3	32.768 kHz Watch type Xtal.
VC1	5-35pF Trimmer
PL2,4,6	8 way
PL3	6 way
PL5	12way
Mini KK Molex 90° square pin wafer (without friction lock)	
3 × 40 pin 2 × 28 pin 1 × 24 pin 4 × 20 pin 9 × 18 pin 8 × 14 pin IC Holders, 1 × 14 pin for NEC clock 1 × 16 pin for Mullard Clock IC Holder, three cell nickel cadmium, Varta MP3, batteries.	

the alarm facility is used, the IC must be held at 5V for the standby period. This means that a low current standby supply is fed to pin 8 of PL4 – when the alarm occurs, this output is taken from pin 3 of IC15 via PL4. The alarm feature can be made to occur once per day or once per year, dependent upon the position of link 1 or 2. Should the power be off (the computer and the clock running on the Nicad battery), both the clock and the RAM will be held operational for longer than a year providing the battery has had sufficient time to charge up previously. Software routines are available for setting the time and date via the sound chip IC12.

Analogue to Digital

The eight inputs for the A/D converter come from eight pins on PL5. The relevant input is selected by doing a dummy write to one of the I/O ports; 8-15 inclusive. The action of writing to one of these ports starts the conversion operation. Coming back after a 100 microseconds and reading from the same port will return the eight bit value representing a voltage between 0 and 5V on the appropriate input pin. For most applications the 5V power supply can be used as the voltage reference for the converter, but in case anybody wishes to measure a precise number of millivolts then a precision voltage reference of, say, 5.12V can be included on PL5. Otherwise, pins 1 and 2 are linked together to supply IC10 with HT and V Ref. The board software demonstrates the A/D converter by using its inputs to move the helicopter display around the screen.

The circuitry described here is contained on an 8" × 11½" PCB, which has a gold plated edge connector conforming to the Nasbus specification. There is no reason, however, why any Z80 can not interface with the board since the signals are basically Z80 data, address and I/O request. Comprehensive software is provided for de-bugging and testing the board; including the generation of a display similar to that on the front cover of R&EW magazine. The I/O PROM is blown according to the I/O map shown in this article. The completed Animation Graphics Board updates the Nascom to set it on a par with virtually any other personal computer on the market today.

■ R&EW

YOUR REACTIONS	Circle No.
Good	58
Average	59
Poor	60

REPAIR THAT OLD BLACK
AND WHITE TV
with the aid of the best seller

"TV FAULT FINDING"

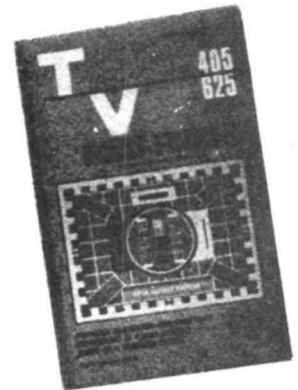

(more than 200,000 copies sold)

5th Edition
Edited by J R Davies
132 pages

Over 100 illustrations, including 60 photographs of a television screen after the appropriate faults have been deliberately introduced.

Comprehensive Fault Finding Guide cross-referenced to methods of fault rectification, described at greater length in the text.

Price ONLY £1.50 (inc P&P)

Make remittance payable to:
**RADIO & ELECTRONICS WORLD
DATA PUBLICATIONS**
45 Yeading Avenue,
Rayners Lane,
Harrow, Middlesex HA2 9RL

**3 x £1
DISCOUNT
VOUCHERS**

**ambit's new
autumn/winter
catalogue**

**is
OUT
NOW!**



**128
PAGES**

70p

**ALL THE 'USUAL' BITS
(Rs, Cs, Tr's, ICs etc)
+ ALL THE
TRICKY BITS**

**at all good
newsagents
or direct**

- * TOKO COILS, INDUCTORS, LC FILTERS
- * PCM FILTERS, VHF/UHF HELICAL FILTERS
- * UNELCO CAPACITORS
- * PCI INTELLIGENT LCD MODULES
- * TOKO SWITCHES : F SERIES/R7000 SERIES
- * ALPS POTENTIOMETERS AND KEYSWITCHES
- * TOYO-TSUSHO COAX RELAYS FOR TX/RX
- * CRYSTAL FILTERS, CERAMIC FILTERS
- * WELLER SOLDERING IRONS
- * COOPER TOOLS
- * TEST EQUIPMENT
- * BOOKS, MANUFACTURERS' HANDBOOKS
- * HARDWARE, CASES, PANELWARE, ETC.
- * MODULES, R&EW KITS
- * RF POWER DEVICES

ORDERS SUBMITTED USING STOCKCODES DESPATCHED
WITHIN 8 WORKING HOURS FOR EX-STOCK ITEMS

*** PHONE ORDER SERVICE — (NO MACHINES!)**

PLEASE NOTE OUR NEW PHONE SYSTEM AUTOMATICALLY STACKS CALLS
IN ORDER OF ARRIVAL SO PLEASE WAIT IF NOT ANSWERED IMMEDIATELY

**8 AM — 7 PM MON — SAT
0277 230909**

*** COMPUTER ORDER SERVICE — 'REWTEL'**

**6 PM — 9 AM 300 BAUD/RS232
(IT MAY BE 24 HRS BY THE TIME YOU READ THIS)
0277 230959**

ambit INTERNATIONAL

200, NORTH SERVICE ROAD
BRENTWOOD, ESSEX
CM14 4SG
Telephone : (0277) 230909
Telex: 995194 AMBIT G

178 for further details

TONNA (F9FT)

**YOUR NUMBER ONE CHOICE FOR
6m, 2m, 70 AND 23cm ANTENNAS**



STOP-PRESS STOP-PRESS STOP-PRESS

JUST ARRIVED

**17 ELEMENT 144 MHz LONG YAGI PRICE
£35.19 CAR £4.00.**

We are pleased to announce that due to the devaluation of the French Franc, the prices of all our antennas have been reduced.

Please telephone for new prices.

Just telephone your order. All prices include VAT.
FOR FULL SPECIFICATION OF OUR RANGE SEND 30p FOR CATALOGUE
Callers welcome, but by telephone appointment only please

RANDAM ELECTRONICS (W)

12 Conduit Road, Abingdon, Oxon OX14 1DB.
Tel: (0235) 23080 (24 hours)



167 for further details



Constructor Series Speakers

**IT'S
SO
EASY**

Have fun, save money, building a Kef design with a Wilmslow Audio CS Total kit. No electronic or woodworking knowledge necessary and the end result is a proven top-quality design that you'll be proud of.

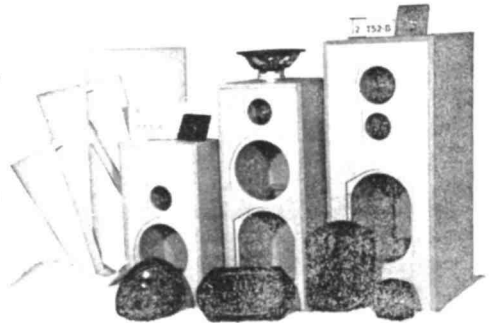

Each kit contains all cabinet components, accurately machined for easy assembly, speaker drive units, crossovers, wadding, grille fabric, terminals, nuts, bolts, etc. The cabinets can be painted or stained or finished with iron-on veneer or self adhesive woodgrain vinyl. Easy foolproof assembly instructions supplied. Set of constructor leaflets sent free on receipt of large S.A.E.

Prices: CS1 (As 101)	£110 pr. inc. VAT, plus carr./ins. £ 5.50
CS1A (simplified LS3/5A)	£103 pr. inc. VAT, plus carr./ins. £ 5.50
CS3 (as 103.2)	£129 pr. inc. VAT, plus carr./ins. £10.00
CS5 (as Carlton II)	£192 pr. inc. VAT, plus carr./ins. £15.00
CS7 (as Cantata)	£250 pr. inc. VAT, plus carr./ins. £18.00



0625 529599

35/39 Church Street, Wilmslow, Cheshire SK9 1AS
Catalogue — £1.50 post free



Lightning service on telephoned credit card orders!



168 for further details

R&EW TRANSCEIVER PROJECT

CONTROL MODULE

Design by Simon Ruffle G4EAG

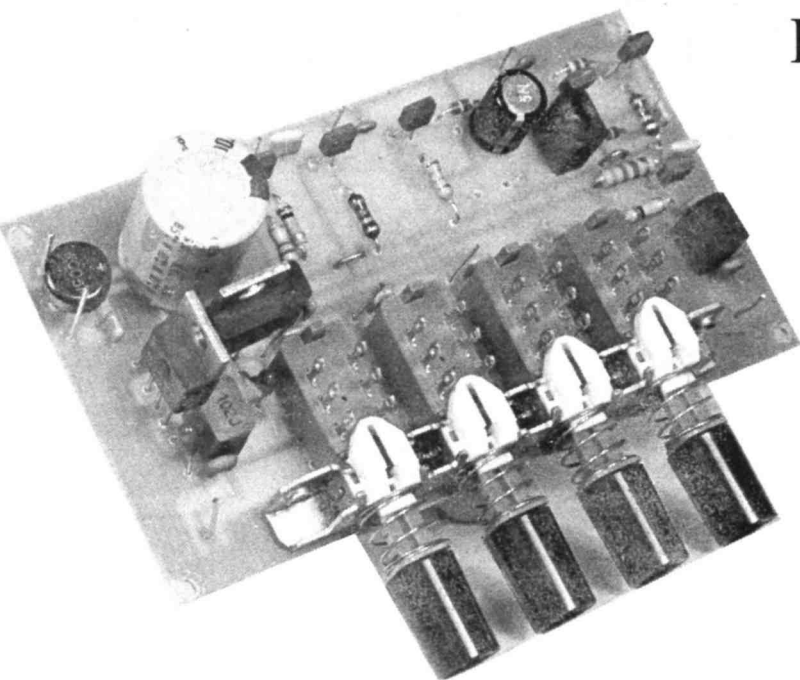

THIS MONTH, the transceiver project is nearing completion. All that remains is to describe the control board.

The block diagram for this board, the exciter section/of the transceiver is shown in Fig. 1. And, since all the modules have been designed for DC switching, the control board - and any front-panel controls - will be free from RF switching problems. There are, however, quite a number of different control signals required and their timing relationships will vary according to the mode selected.

The control board has been designed to complement a basic amateur transceiver system. It provides all the usual facilities

including a choice of positive or negative receiver mute lines. The module is very simple to use; just four pushbuttons mounted on the PCB. These cater for Upper Sideband, Lower Sideband and CW, leaving a spare button for, say, FM. There is also an earthed input, which provides transmit facility via the morse key, the microphone push-to-talk button or a VOX relay.

The exciter module requires 15 to 18 volts AC, so there is a full on-board power supply. If DC is already available then the bridge rectifier can be omitted. On the output side, the control module provides the mode 'enable' lines, the 'keyed' line, a

supply for the mixer board oscillator, receiver muting and a DC supply to the antenna XO relay - when CW is selected, a semi break-in delay circuit is brought into operation.

The control module is entirely DC switched, which explains the comprehensive RF decoupling. The trouble with solid state control circuits, operating in the high RF fields found in the average radio shack, is that they can take on a life of their own through RF pick-up. To combat this, all major 'dangling' leads have low-pass filters, inputs and outputs are decoupled to earth and the module should be mounted in a screened enclosure.

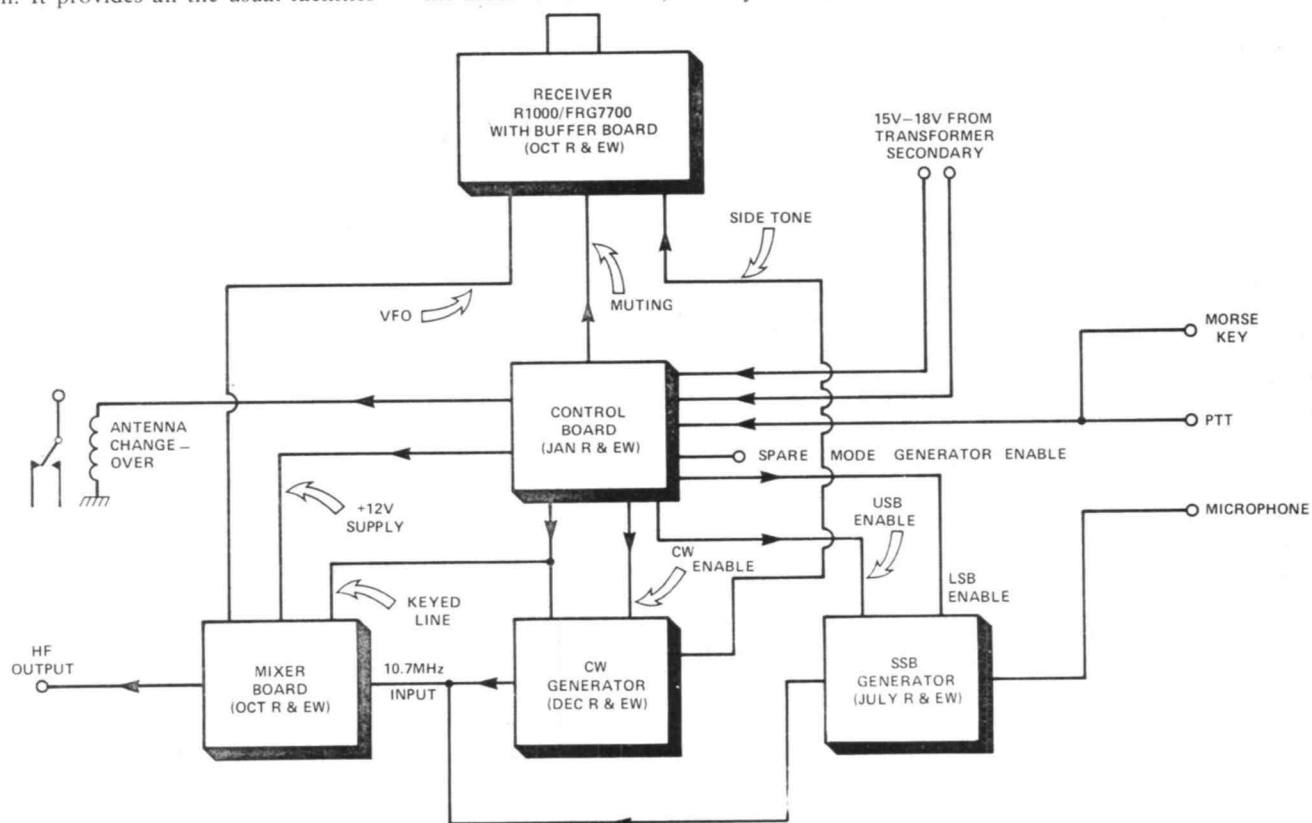

Figure 1: Block diagram of the transceiver, showing how the modules are linked together.

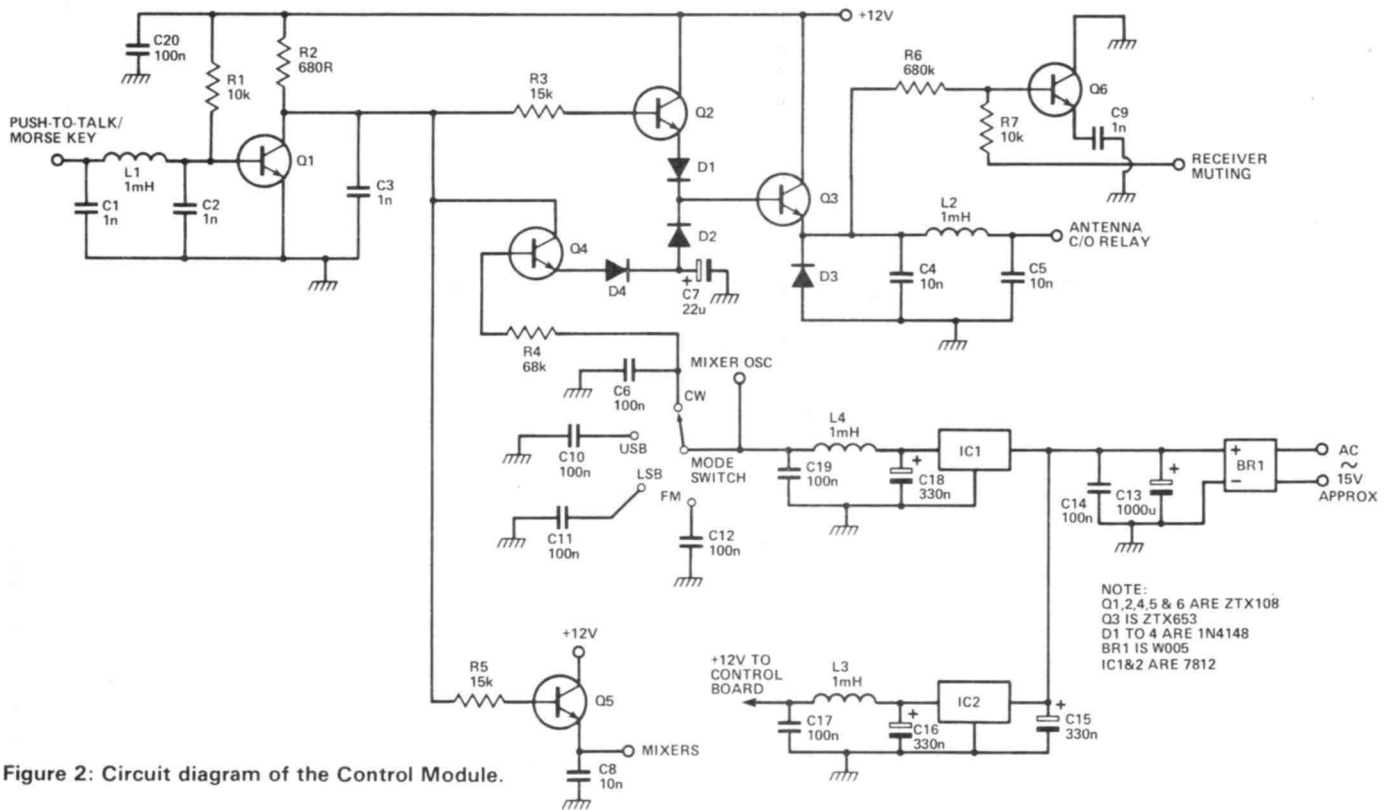

Figure 2: Circuit diagram of the Control Module.

Circuit Description

The control board has been designed around a single earth-to-transmit line, which can be keyed at CW speeds. Transistor Q1 inverts the keying input and provides a signal that goes to +12V on transmit. Transistors Q2 and Q3 form the antenna relay driving circuit. D3 protects Q3 against back EMF spikes from the relay.

We used coaxial relays here, but since these are too slow to change over at morse keying speeds, the control module employs a semi break-in delay circuit - activated when the CW button is selected. This circuit holds the relay on transmit for a short time after every key depression. If you pick the right value for C7, the relay can be held on transmit throughout the CW transmission. Transistor Q4 is

switched on hard by the CW enable line (via R4) and allows current to flow from the keyed line into C7. When the transmit key is depressed, Q2 and Q3 close the relay and C7 charges via Q4. When the key is released, C7 discharges (via D2) into Q3's base which keeps that transistor on and holds the relay closed until C7 is fully discharged. By that time, the morse key will have either been pressed again or the transmission will have ended.

Transistor Q5 provides the keyed line supply of around 11 volts, which feeds IC1,2 (mixer board) and the sidetone oscillator in the CW generator. Q6 provides the receiver muting function, with its base fed, via R6, from the antenna relay line. This links the receiver muting with the disconnected antenna

function.

The circuit is connected for a negative muting line (Fig. 2) - earthed to mute. R7 'steals' some negative potential to bias the

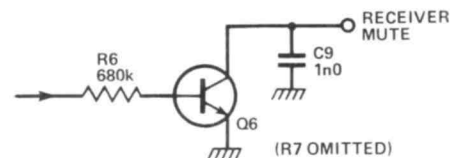

Figure 3: Modification for positive mute lines.

transistor off. If your receiver's muting voltage is positive, then the circuit of Fig. 3 should be substituted (R7 is no longer necessary and Q6 should be reversed on the PCB).

The control module is equipped with its own power supply - consisting of bridge rectifier and smoothing capacitor - which has two separate regulated supply lines. One powers the mixer board oscillator and mode generators. The other, based around RV2, powers the control board, mixers, sidetone oscillator and the antenna relay. Any transformer, with a secondary in the range 15-18 volts (at 600mA), should be suitable for powering the system. Other stages of the transceiver should be powered from a separate secondary.

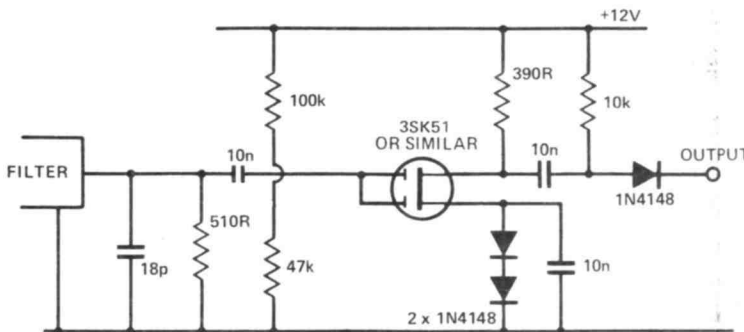

Figure 4: Alternative MOSFET buffer stage for the SSB Generator.

Construction

Building the control board is straightforward. The PCB is shown in Fig. 6. It shouldn't need stage-by-stage testing, but do not connect any of the modules until you have checked each output pin (with a voltmeter) and are sure the control module works. The interconnection is straight-

forward using ordinary wire. Note that the mixer board oscillator has its own supply pin, and its output pin feeds the mixers and CW generator keyed line. Connect each mode 'enable' line to the pin nearest the pushbutton switch you have selected; remember that the CW switch is already on

the far right. This completes the 'exciter' stages of the project and only leaves 'transceiver testing' and 'getting on the air', to be described next month. Once enough of these transceivers are operating, the author will start an 80m net - anyone interested?

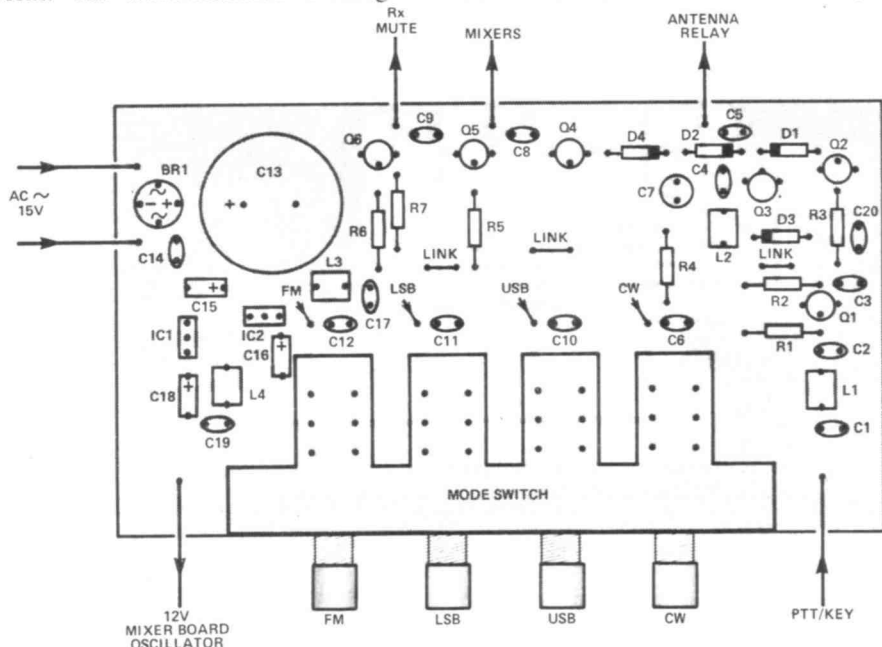
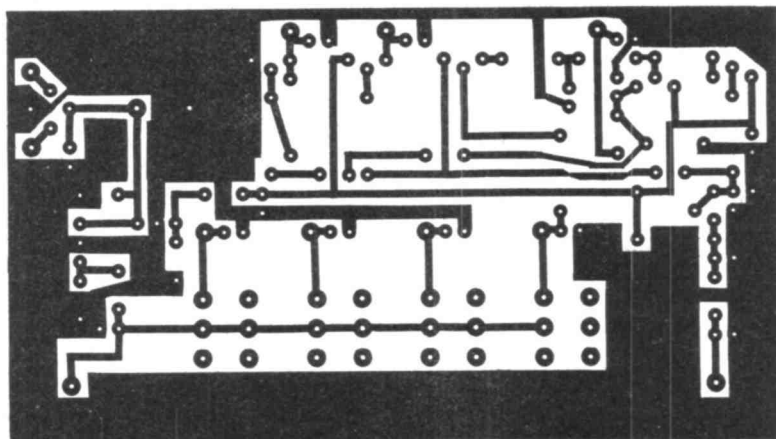

Figure 5: The Control Module components overlay.



PARTS LIST	
Resistors	
R1	10k
R2	680R
R3	15k
R4	68k
R5	15k
R6	680k
R7	10k
Capacitors	
C1,2,3,9	1n
C4,5,8	10n
C6,10,11,12,14,17,19,20	100n
C7	22u electrolytic
C13	1000u electrolytic (PCB mounting)
C15,16,18	330n tantalum bead
Semiconductors	
Q1,2,4,5,6	ZTX108
Q3	ZTX653
IC1,2	7812
BRI	W005 rectifier
Miscellaneous	
L1,2,3,4	1 mH choke
	Four-way push button switch
D1-4	1N4148

Figure 6: Trackside pattern of the PCB.

■ R&EW

YOUR REACTIONS	Circle No.
Good	64
Average	65
Poor	66

LOW COST PROFESSIONAL TEST INSTRUMENTS

sabtronics
FREQUENCY METERS
100MHz, 600MHz, and 1GHz Models
from £62

Belemic
Hand Held
Analogue and
Digital
Multimeters
16 Models
from £18.75

electro RST

- ★ FREQUENCY METERS
- ★ ANALOGUE MULTIMETERS
- ★ DIGITAL MULTIMETERS
- ★ FUNCTION GENERATOR
- ★ OSCILLOSCOPES
- ★ POWER SUPPLIES
- ★ LOGIC PROBE
- ★ SCOPE PROBES

Write or phone for illustrated test instrument catalogue and price list
Black Star Ltd.
9A, Crown Street
St. Ives, Huntingdon
Cambs. PE17 4EB
Tel: (0480) 62440 Telex 32339

170 for further details

NEWS BACKGROUND

This month, NB takes a look at software piracy and wonders if there isn't actually a rather obvious solution. Like all good popular press people, we tried hard to find an excuse to harrass HRH and Ms. Stark, but no luck . . .

BARELY A NIGHT goes past on the telly without some shadowy

back-lit figure confessing to all manner of dastardly piracy in the video film business; probably because since the bottom dropped out of the trade, the money paid by the TV "shock-horror" specialists is rather better than that available from the rental of shaky fourth hand copies of ET!

A lot of heads dived into the sand at that Westminster riverside residence of the lawmakers when the subject of video piracy reared its ugly head, and there seemed to be absolutely no suggestions from anyone as to what might be done. The film moguls suggest things ranging from disembowelment to million pound fines, the politicians suggest (surprise) a commission/enquiry.

The findings of the current investigations will make interesting reading, but they are now too late to prevent this software piracy moving into the realm of socially acceptable misdemeanours along with doing 35 MPH in a 30 MPH limit, using the firm's telephone for private calls (yes, strictly speaking it's imprisonable if exploited in excess). Moreover, would you turn down the opportunity of getting hold of a copy of ET (or whatever your video bag may be) if offered the chance?

Licensed to view

How about a rather simplistic solution? Why not just licence all video sales and rental outlets in exactly the same way as Off-Licences are presently policed? The rationale is identical: the operators have something substantial to lose if they break the rules (viz. their livelihoods), and the subject of the licence is a commodity which is an ideal target for abuse for organised criminals. Particularly nastily depraved productions have recently featured in the news, and these two are probably better regulated by the prospect of loss of licence than some useful publicity and a relatively trivial fine.

The apparently grossly inflated prices charged by the film operators cashing-in has probably contributed as much to the wave of piracy as anything, so maybe they might be persuaded to charge a more realistic sum for the kosher offerings if they are offered a more substantial degree of security for their wares.

Licensed to Compute

The same technique might be applied to anyone selling software that is not of their own origination. Some pundits in the USA now estimate that as much as 90% of the software circulation in the hobbyist market is pirated.



".. COURSE IT ISN'T STEALING, IT'S A PERIK OF THE JOB."

The laws of copyright are tedious and totally unsuited to current market conditions - and simply spinning out a stream of legislation will only benefit lawyers. There may be some problems associated with the issue and maintenance of licences to vendors, but as long as the government gives the contract to run the licencing system to private enterprise, then it stands a chance of being workable rather than a huge publicly subsidised white elephant.

One of the most persuasive reasons for a computer hobbyist using pirated software is the simple fact that if you actually play the game and pay the fee, then many fellow enthusiasts regard you as being somewhat eccentric. It's a bit like going to the door where the 10p mechanism is still working, when some vandal has ripped it off the other 5 in the public loo.

Owt for nowt?

One thing is rather plain in this life, and that is the best things in it are not always free. The only longterm solution to the problem of software copyright is a complete change in public morality towards the question, recognising that it is just as much theft to copy video software without payment of royalty, as it is to help yourself to the first item on the shelf at Harrods that takes your fancy.

The lawful right of vendors to enjoy some pecuniary advantage by the sale of their wares is the same in both cases - but it's a good deal more difficult to prove cases of theft where the "goods" are intangible.

Another illustration of the "you get what you pay for" concept is illustrated by the

apparent truth that those magazines who pay most for their material end up with the best and most interesting material. As our followers will know, commercial consciousness is part of our policy, so *R&EW* has always been prepared to bid the most to get the best.

Availability and R&EW

It's becoming increasingly apparent that this noble tome is not as readily available as it ought to be in some parts of the country. The Petersfield area has been reported on several occasions to be a desert in the lives of most technologically conscious people, and despite remonstrations with newsagents, it seems that *R&EW* is classed as a "firm sale" only item. That means to say that your newsagent will only order against firm orders from customers - with the bare minimum of spares for shelves (which go very quickly as you might guess), and all this despite the fact that our distributors offer full SOR to all outlets.

If you find such a newsagent who claims we play hard to get, report him to our investigations branch in the subs. dept, and the appropriate action will be taken.

We don't propose to kick in his windows, but we will see to it that *R&EW* blossoms forth in adequate numbers to satiate the desires of your vicinity - or he'll have Gary and the lads pop round and tell him his fortune . . .

YOUR REACTIONS	Circle No.
Good	4
Average	5
Poor	6

NOISE SQUELCH INSTALLATION

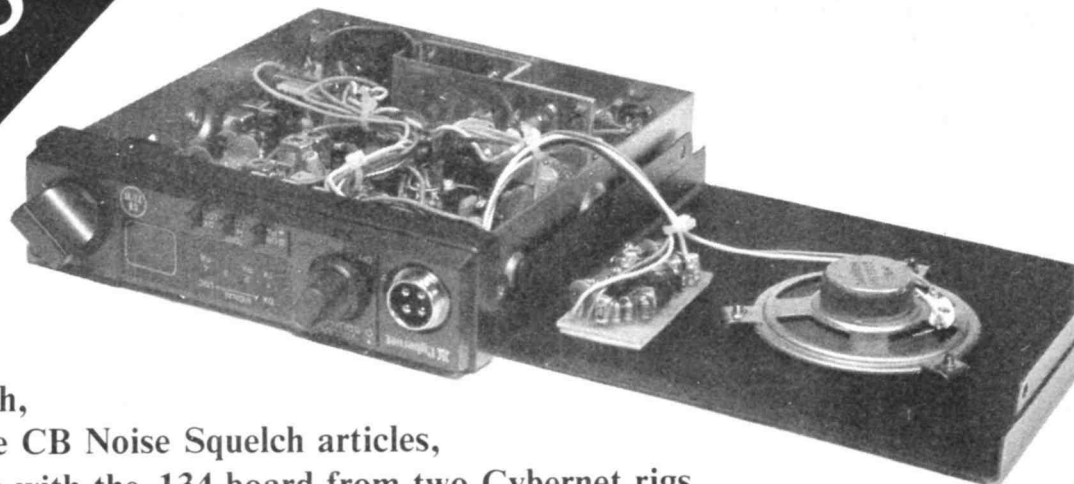

This month, in the last of the CB Noise Squelch articles, Adrian Barnes deals with the 134 board from two Cybernet rigs.

THE CYBERNET BETA 2000/1000 is a fairly popular chassis, found in rigs made by Fidelity, York and Binatone. Being fairly well designed (as far as layout is concerned), most of the components are laid down on the board. Custom-made potentiometers are used for the volume and squelch controls; which is useful for the manufacturers, but means that modifications will necessitate cutting several tracks on the PCB.

In Fig. 1, it can be seen that one end of the squelch pot is disconnected from D15 and re-connected (via a series resistor) to pad 2 of the module. The series resistor sets the squelch control offset. Its value depends upon personal preference for the muting position on the pot - try values between 5k and 20k. The other end of D15 is grounded, in order to turn the on-board mute fully off. This simultaneously bypasses the earthed end of the squelch pot, which is cut free and not connected to anything (see Fig. 2).

Power (pad 4) can be taken from a convenient blank pad on the track, leading from the on/off switch as indicated in Figs. 1 and 2. Similarly, the negative (pad 5) is connected to another convenient blank pad on the track leading from the earthed side of the squelch pot.

Connecting the input and output requires track-cutting. It is easier if you remove (as previously indicated) C86 and connect the module in the space. However, changing levels (caused by altering the top cut) shift the squelch pot offset giving unsatisfactory operation. Thus the unit is installed before the de-emphasis components, at the output from the FM IF detector (Fig. 3). To facilitate this (refer to the PCB), remove link J23. Re-join the junction of R74 and C86 with an underboard link; by-passing pin 7 of the IC. Cut the PCB track close to the IC, so that it is completely disconnected. Then connect the input of the module (pad 1) to pin 7 of the IC and the output to the link which bypasses that link.

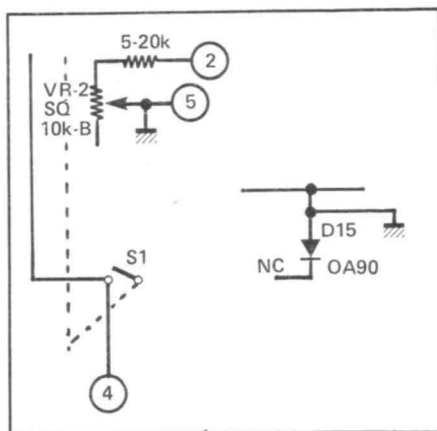

Figure 1: Squelch pot. connections.

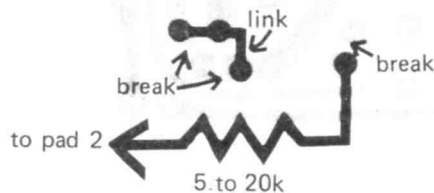

Figure 2: PCB alterations.

Now, all the connections are complete and the module can be mounted with double sided sticky pads, ensuring no shorts on the case. The best place is probably on the base, next to the speaker (see Fig. 4), remembering that the module must not foul anything when the lid is replaced.

■ R & EW

We are grateful to Anthony Day for the loan of one of the Cybernet rigs appearing in this article.

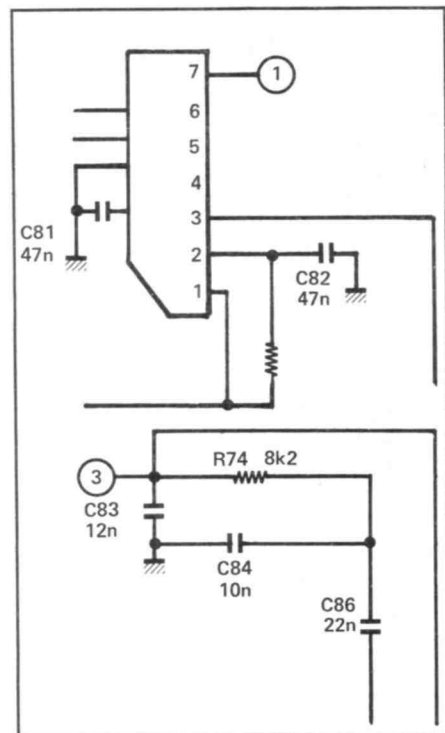

Figure 3: Input/output connections.

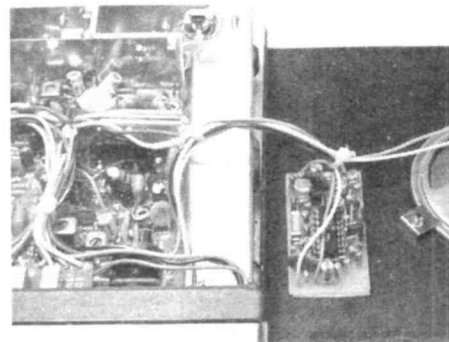

Figure 4: Mounting the module.

YOUR REACTIONS	Circle No.
Good	16
Average	17
Poor	18

PROJECT PACKS

SSB CONTROL MODULE

Control module for use with the previously published SSB transceiver modules. Kit includes: PCB, all components, switches and knobs.

Stock No.
40-10705

Price
£ 8.07

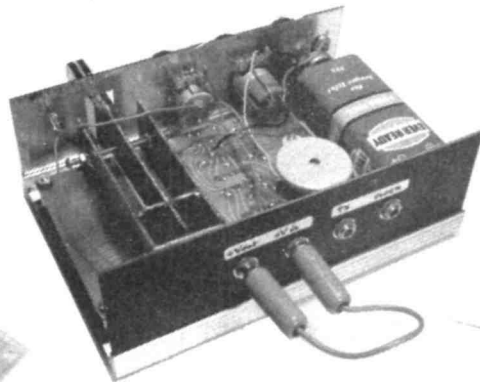

CMOS MORSE KEYER

Complete kit of parts including: PCB, all components, case (undrilled), pots and knobs, plugs and socket, plus materials to construct paddle.

Stock No.
40-04000

Price
£18.10

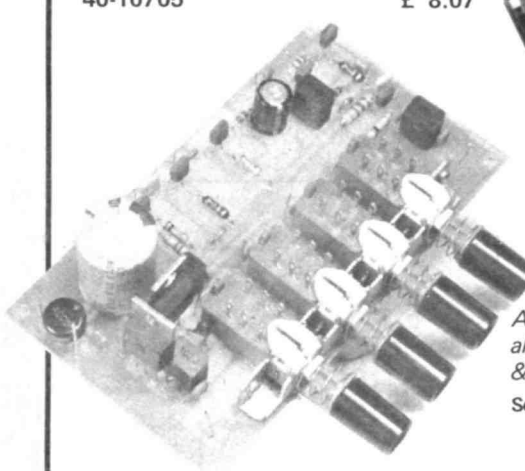

All prices include VAT @ 15% Please allow 21 days for delivery. Postage & Packing 60p per order.

Send your order to **Ambit International**
200, North Service Road,
Brentwood, Essex CM14 4SG
Tel: (0277) 230909

Access/Barclaycard Welcome.

Z8 MCS

Latest add-on for the expanding Z8 Tiny Basic development system. Available as a kit or built and full tested.

Stock No.
40-00812
40-00813

Kit
Built

Price
£35.60
£42.30

PROJECT BOARDS

April	Rewbichron Rx Board	£3.04
	2m Pre-Amp	£1.11
	Key Pad Security Lock	£1.79
	KB4417 (Undrilled)	£0.69
	KB4413 (Undrilled)	£0.58

May	UOSAT	£10.17
	4-way Distribution Amplifier	£5.91
	pH Meter	£5.04
	KB4412 (Undrilled)	£1.43
	ULN2240 (Undrilled)	£0.94

June	Radio Control Tx	£3.58
	2ch Mains Timer - Display	£6.40
	PSU	£2.07
	Triac	£2.07
	Switch	£0.85
	CB Selcall	£3.33
	ZX81 Keyboard - A	£2.99
	ZX81 Keyboard - B	£2.99
	0-30v PSU	£4.50
	2m PA Mk II	£5.91
	ULN3859 (Undrilled)	£0.96
	LM1035 (Undrilled)	£1.29

July	SSB Exciter	£3.87
	HA12017	£2.48
	DC Controlled Pre-Amp	£12.00
	Radio Control	£1.84
	Autobridge	£3.50
	Autobridge RF Head	£2.25
	Autobridge LED	£0.73

August	18W Power Booster	£3.74
	ZX81 Expansion Board	£9.60
	Ga As Fet Pre-Amp	£4.37
	Ga As PSU	£1.54
	Multiband Up Converter	£5.46
	KB4436 (Undrilled)	0.67
	Switch Mode Power Supply (Undrilled)	£2.92

September	CB Noise Squelch	£1.20
	Drill Speed Controller	£4.76
	4/6/10m Pre-Amp	£1.86
	A/D Converter	£3.73
	Airband RX	£8.83
	DFM	£4.83
	DFM Display	£2.07
	4448 (Undrilled)	£0.93

October	70cm PA	£4.02
	SSB Mixer	£2.89
	SSB Buffer	£0.98
	2m GaAs FET Pre-amp	£4.14
	Train Controller	£4.96
	U264 (Undrilled)	£0.46
	MF10 (Undrilled)	£0.69

November	2m Converter	£4.14
	20Hz - 150MHz DFM	£2.90

Video Interface:	Thorn TX9	£3.95
	Amstrad CTV1400	£2.21
	TDA4420/1	£1.10
	DNR (From Oct. Issue)	£3.31

December	Wide Band Amp	£2.79
	SSB CW Generator	£1.86
	PPM - Mono	£1.86
	PPM - Stereo add-on	£1.86
	Auto NiCad Charger	£5.83
	TX10 Video Interface	£3.10

JANUARY 1983

Z8 MCS	£9.93
CMOS Morse Keyer	£3.72
SSB Control Module	£2.48
Tracking PSU (Undrilled)	£1.89

All Prices include VAT @ 15% Please allow up to 28 days for delivery. Postage & Packing 60p Per Order.

Send your orders to:
200, North Service Road, Brentwood, Essex CM14 4SG
Access and Barclaycard Welcome.

SEND YOUR ORDER TO:

ambit INTERNATIONAL

200, NORTH SERVICE ROAD
BRENTWOOD, ESSEX
CM14 4SG
Telephone: (0277) 230909

9 8 7 6 5 4 3 2 1 0

A handy resistance substitution box.

Design by David Strange.

The R&EW Decade Box allows selection of resistance in 1 ohm steps (up to 999999 ohms) via thumbwheel switches. This gives the unit a compact size and a wide range of applications.

Since the box is a piece of test equipment, it is worthwhile using good resistors. If $\pm 2\%$ tolerance resistors are used throughout, then $\pm 2\%$ tolerance will be maintained for any selection.

The electrical design could not be simpler, as all nine resistors on each individual switch are the same value. They are connected in series, as a potential divider, to the poles between 0 and 9.

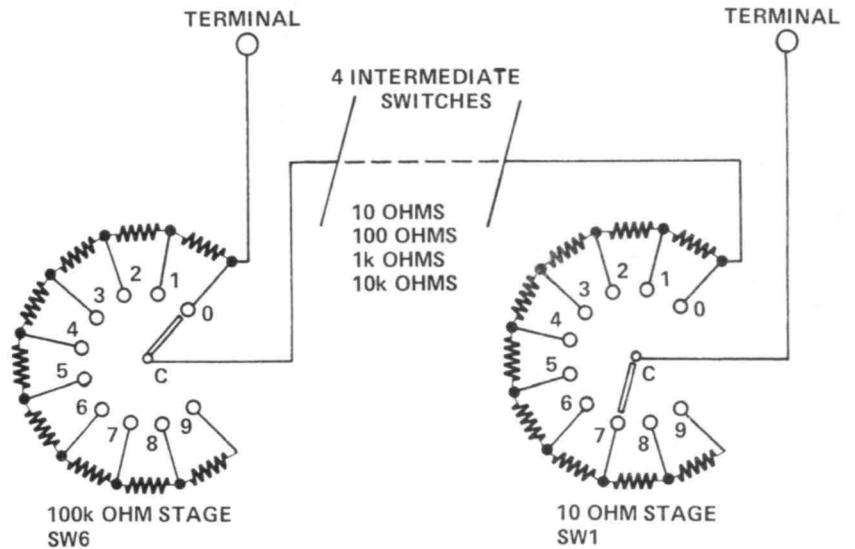

Circuit diagram for two of the six thumbwheel switches.

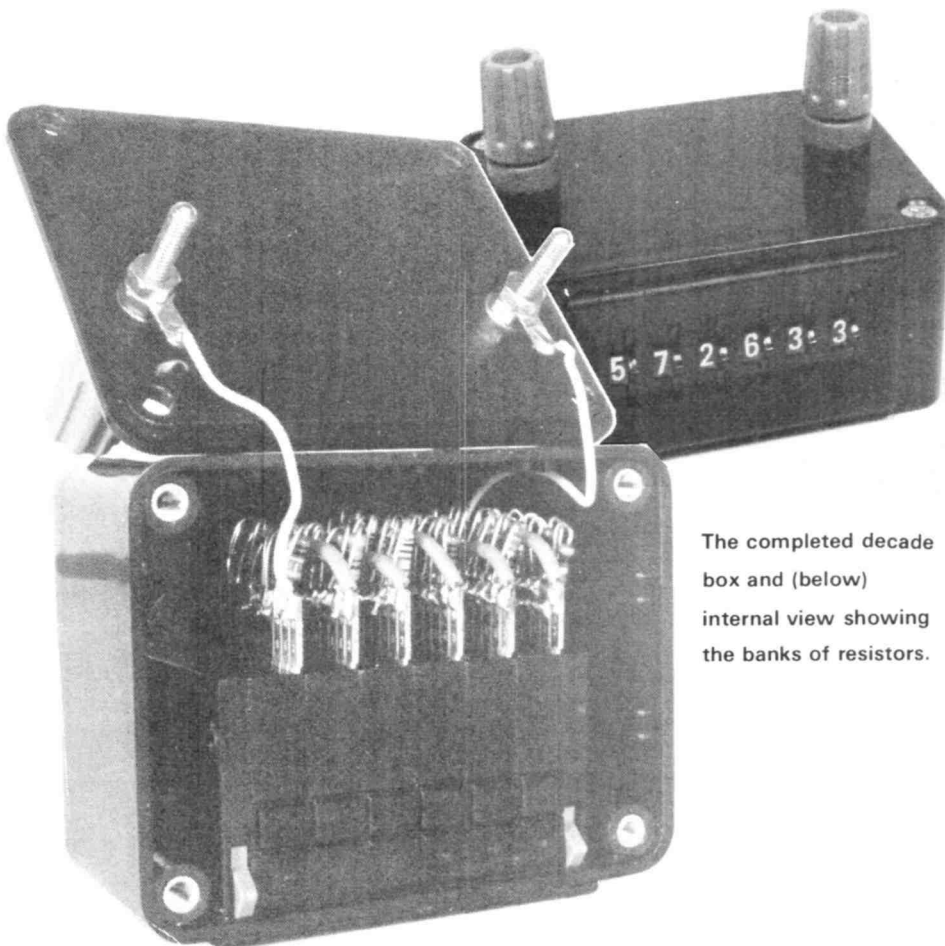

The completed decade box and (below) internal view showing the banks of resistors.

Therefore, at position 0 there are no resistors; at 1 there is 1 resistor; at 2 there are 2 resistors, and so on. Each switch is in series with the next so that the resistors add together from switch to switch.

The box construction can be seen from the photograph. Sizes are dependent on the switches you select. The oblong cut-out, for the switches, is best cut by first drilling a series of holes inside scribed dimensions. The perforated piece can then be removed by careful use of a sharp knife. Once the centre has been removed, the opening can be cleaned up to the scribed lines using a file.

All resistors should be soldered into place before the switches are finally bolted and wire linked together. The switchbank is then secured and wired up to the terminals.

■ R&EW

YOUR REACTIONS	Circle No.
Good	10
Average	11
Poor	12

FEEDBACK

Points arising over past constructional projects.

SSB Generator (July '82)

R13 should be 47R to obtain a higher output level.
The network R12/C29 can be removed without detriment to the system.
The crystal filter input requires an 18p capacitor across it.
The module requires a diode switch output network similar to the CW generator.

Mixer & Buffer Modules (October '82)

Resistor R11 and capacitor C26 must be added to the circuit diagram (they were not omitted from the PCB).
The diagram shows a line from the oscillator to the +12V supply - this should be removed.
Capacitors C8,18,21 and 24 should be 10n.

CW Generator (December '82)

The decoupling capacitor, C10 should be 1n.
The twin-T oscillator capacitors, C11 and 12, should be 22n.

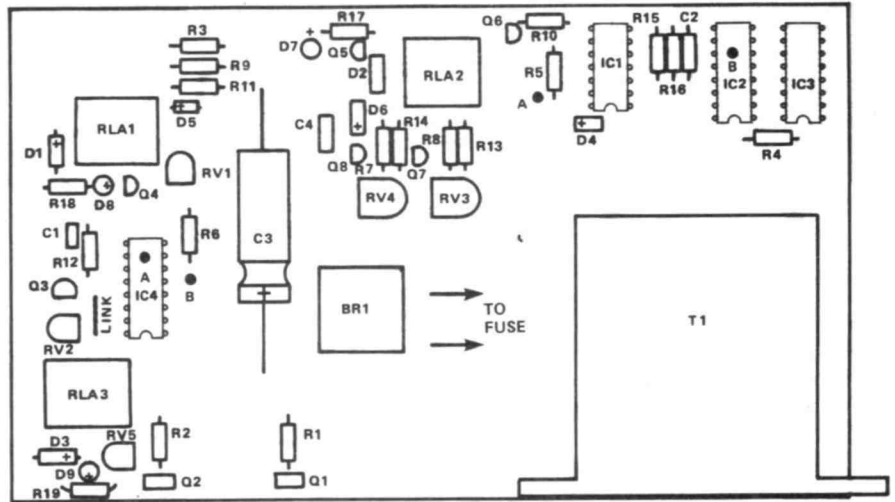

Figure 1: Revised overlay for the NiCad charger.

Ni-Cad Charger (December '82)

R4 should be 82R and R5,17,18 & 19 should be 1k8.
R7,8,9 should be 47k and R13 & 14 should be 100k
Diode, D6, should be 8V2 and D4 is 15V.
Also the presets RV3 & 4 should be 5k.

The final paragraph of the circuit description now reads:
Adjusting the potentials at Q7 and Q8, with RV3 and RV4 respectively, causes

them to switch on at different levels. Both outputs are summed (one is inverted) and inverted using a NAND gate, which switches RLA2 via R5 and Q5. Thus, the relay will be off at one range of voltages and on (breaking the charge circuit) if the test point is outside that range.
In addition the initial setting up procedure is modified as follows: Set RV1,2 & 5 to mid-track. Adjust RV3 so the potential between the wiper and negative end of the track is 8.75V. Do the same for RV4 so the PD is 10.2V.

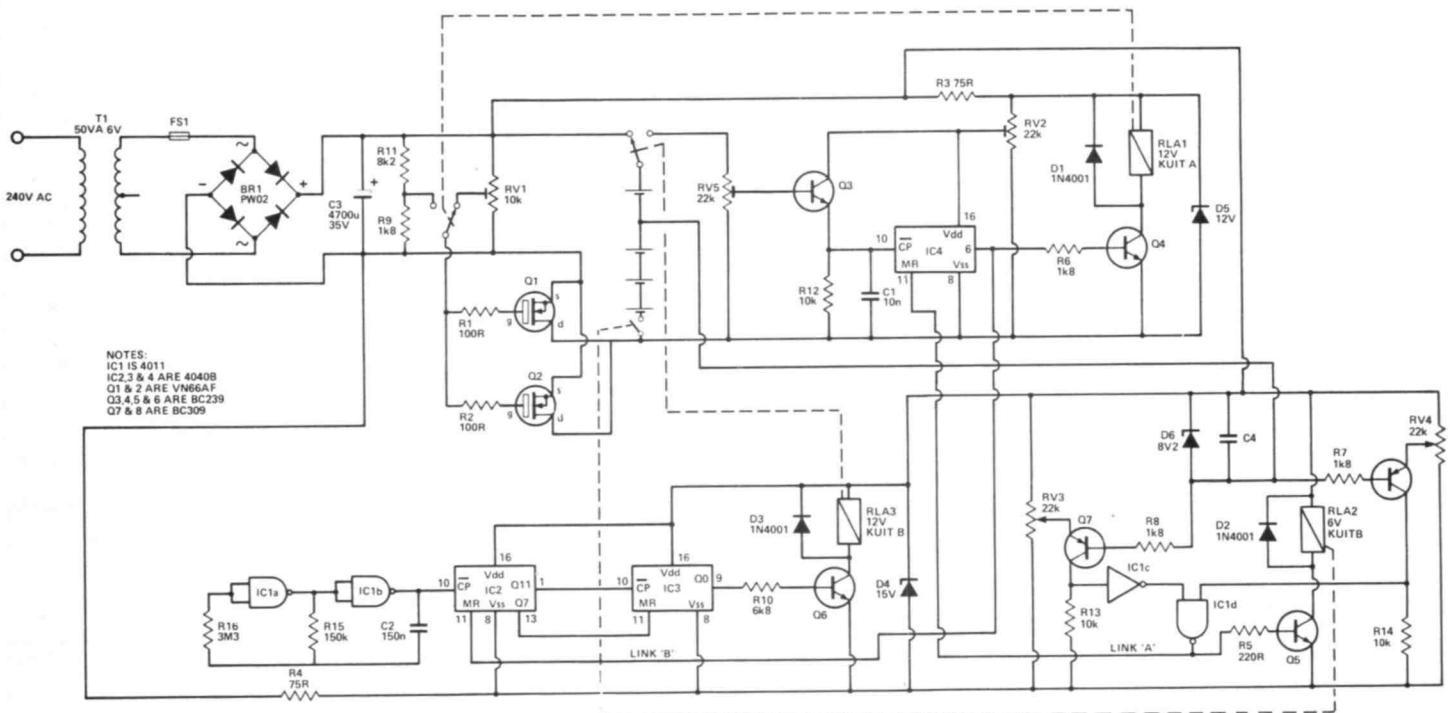
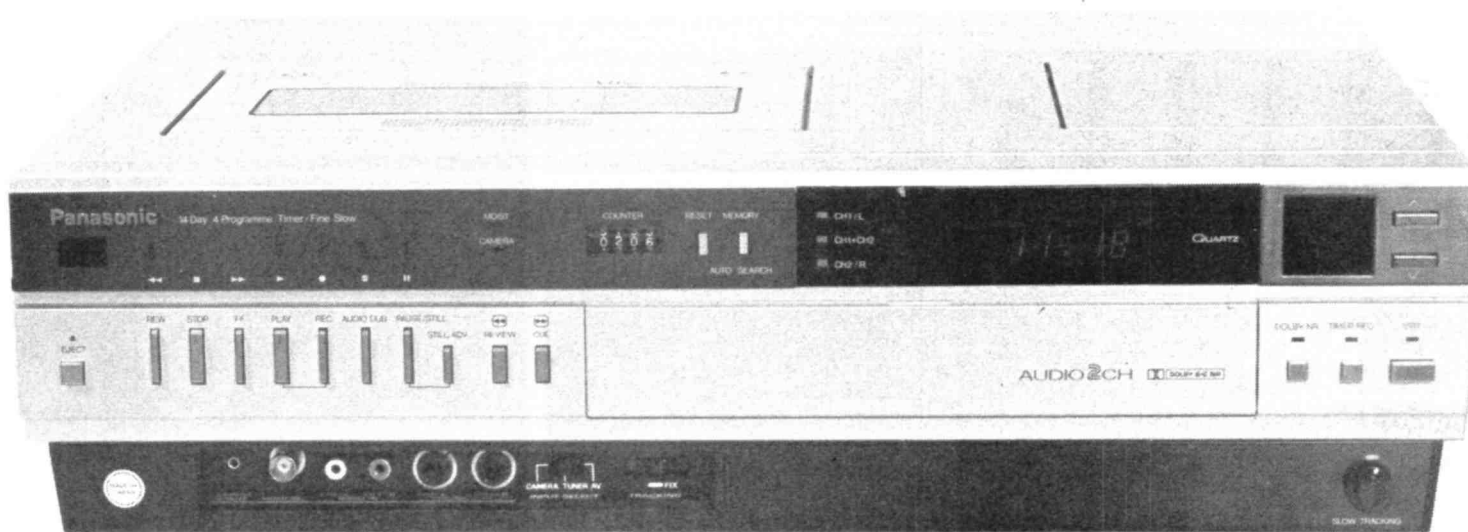

Figure 2: Corrected circuit diagram for the charger.

PANASONIC NV 7800



A feature packed flagship recorder. Peter Luke has put the machine through its paces.

The 7800 represents the top of Panasonic's range of video recorders and offers just about every facility that the potential videophile could desire. The most noteworthy amongst this list of features is the provision of a stereo sound capability and the provision of the new Dolby C noise reduction system.

A large number of facilities means an equally large number of switches and buttons to control them and some machines in the 7800's class present a confusing array of such controls. It is to Panasonic's credit, however, that the 7800 has managed to produce a tidy, uncluttered, recorder that is elegantly straightforward in operation.

Looking Good

The 7800 is a little larger than many VHS recorders, but then as we've said, it packs a lot of electronics. The front panel carries all tape transport controls plus various status switches (on/off, timer etc.) and channel up/down buttons. Two flaps conceal the clock and timer setting section and a full complement of signal in/out sockets.

The 24 hour clock has a large, bright, display and the channel number readout is similarly large and easy to read.

The other controls are almost anachronistic these days being tracking adjustments for both normal and slow playback speeds.

The rear panel houses the RF input/output connectors as well as some additional signal input/output sockets including an AV output, bringing together all the signals necessary for record and playback in one DIN type connector. This arrangement will be welcome in many AV set ups, cutting down the connections between recorder and monitor to just one.

Other outputs are a video out connector and the left and right audio outputs.

The division of input/output facilities between the front and back of the recorder is eminently sensible. Those that are likely to be permanently connected in a 'domestic' situation (audio out) being at the rear, where any wires will be out of sight, while those that are likely to be used only occasionally (video in) being at the front, and thus easy to get at.

First Steps

The 7800 features a now standard test pattern generator to aid initial tuning of a TV set to the frequency of the recorder's RF modulator. The frequency of this modulator is fixed, and although very unlikely to cause problems, if this were to cause any conflict with a broadcast transmitter, it would require the services of your dealer to alter it.

Tuning the 12 channels that the 7800 is capable of receiving to the frequencies of your local TV stations is accomplished with a set of thumbwheel presets concealed under a top panel flap. Although this manual method of tuning is preferred by this reviewer, some form of electronic tuning is becoming the norm on more expensive recorders nowadays.

One thing to watch is that the source selector switch (video, tuner, AV) is in the tuner position before attempting to bring in any off-air signals. The position of this switch is however adequately flagged by front panel indicators, a central LED being illuminated when it is in the video position while the channel indicator LEDs are extinguished in all but the tuner position.

This switching, rather than the priority input selection of some recorders, is a valuable feature.

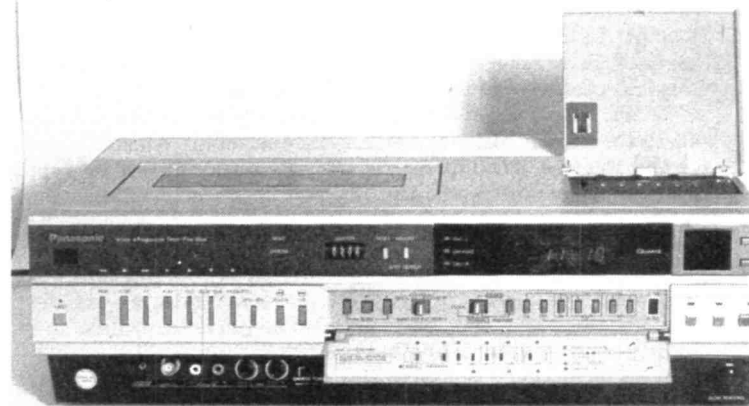

The 7800's array of controls are, in the main, hidden behind a number of flaps.

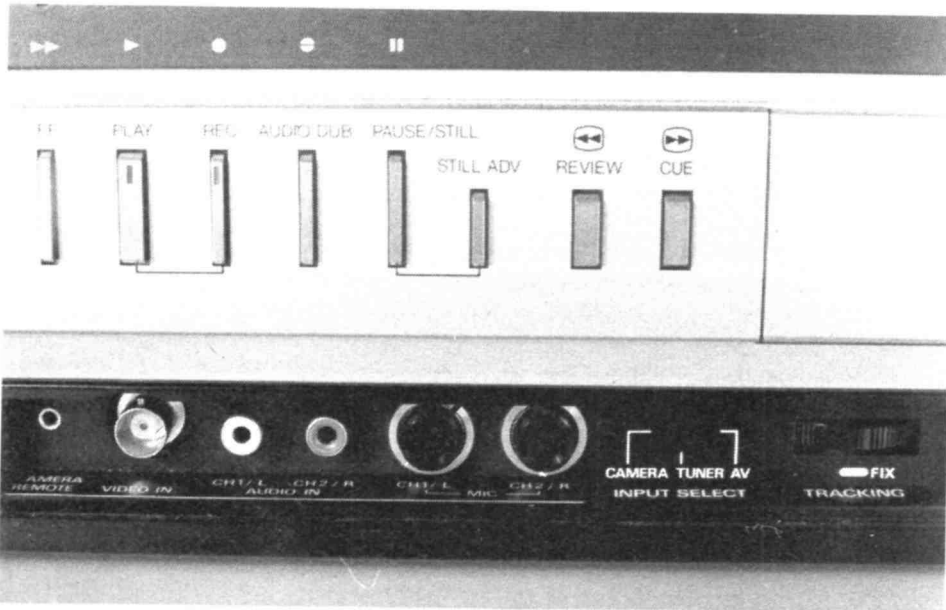

The tape motion controls are rather small and tricky to use.



The rear panel features a useful AV plug that brings together all video and audio signals.

Wheels in Motion

Having set the recorder up, the first cause for complaint becomes apparent and that is that the front panel motion controls are far too small for convenient operation. In particular, there is only a marginal difference in the size of the major controls (play and stop) and the other less important functions. This means that a certain amount of care is necessary if the wrong function is not to be selected. In fact overall operation is far more convenient if controlled from the infra red remote control unit. This has 12 channel select buttons, instead of the front panel's step up/step down control as well as a far more sensible arrangement of the various controls.

The remote control unit includes power saving circuitry that limits the IR emitted to a single pulse for many functions while providing a continuous 'beam' when this is necessary.

Returning to the transport, this is very quiet in operation, although the controlling solenoids do 'bang and click' with rather more volume than most other machines that have come our way. On pressing play, the off-air signal is maintained until the recorder's circuits have stabilised (this takes some five seconds) whereupon the play back signal is switched in.

Visual search in both directions is nine times normal speed and produces a viewable display although accompanied by the familiar VHS noise bars. A slow playback at $\frac{1}{30}$, $\frac{1}{15}$ and $\frac{1}{4}$ of normal is also provided as well as a twice speed facility. In this latter mode, sound is not muted. A pause/still function plus a frame advance facility together with the obvious rewind and forward controls complete a comprehensive range of tape transport facilities, even eject is under solenoid control - unusual on VHS top loaders.

On the whole a good transport system with the reservations about the small controls and rather noisy solenoids. An additional dislike was the fact that the cue/review buttons must be kept pressed during fast search. This reviewer far prefers a momentary action on these controls, resuming normal speed playback with the play button.

The 7800 provides, in addition to memory rewind (the tape will stop when tape counter equals 0000 - the tape counter incidentally is a rather inconsequential mechanical affair) an index facility. This records a short pulse at the start of any recording. This enables sections recorded on the same tape to be quickly located and is a valuable facility on any recorder. One minor point is that, although the recorder can be put into the record mode from a paused playback picture - handy for assembly editing - in this case the index pulse will not be recorded.

The quality of the recorded picture offered by the 7800 is as good as that found on today's generation of recorders and better than some. The video noise figure of less than 43dB seems to be almost an industry standard and there was little chroma shift/noise apparent. The audio capabilities of the 7800 are however, out of the ordinary.

B, C and Stereo

The 7800 provides the latest facility to find its way into video recorders, namely the ability to record stereo sound. At the moment the BBC are undertaking experimental stereo TV broadcasts from their Crystal Palace transmitter but still have made no firm commitment to providing stereo sound in the near future.

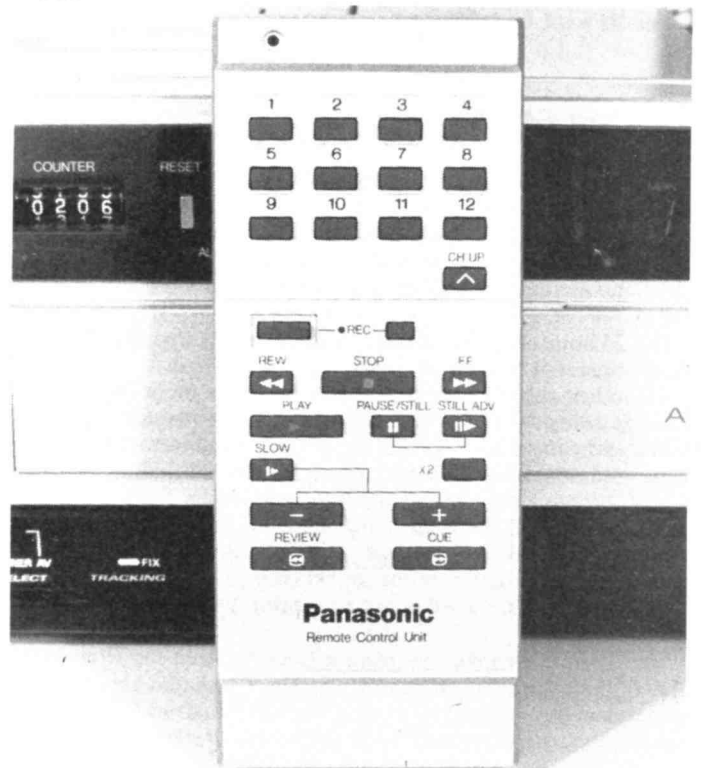

The full function IR remote control unit.

At present therefore this stereo facility can only be appreciated when playing back prerecorded stereo tapes, of which there are an ever growing numbers, or to record the occasional TV and simultaneous VHF radio broadcasts (some may also appreciate the option of two sound tracks when producing their own video productions).

To listen to the stereo sound one will also need one of the latest stereo TV sets or to rearrange the hi-fi, and possibly living room, to place the TV set at the centre of the sound stage.

A lot of trouble to go through but having gone completed the exercise there is no doubt that a stereo sound track does add to the enjoyment of programs.

One of the BBC's operas from their Wagner Ring Cycle series and was recorded together with the radio 3 transmission. Playing back the result, via well positioned external speakers made the experience all the more enjoyable in the opinion of a couple of opera lovers who had not had the opportunity of viewing the original 'in stereo'.

Stereo also adds a little more punch to the films such as Star Wars and, as after its TV exposure, most of the UK has a copy of this, stereo will keep the 7800 owner one jump ahead of the crowd. It is, however, in the area of music software, not necessarily opera, that the greatest quantity of material is likely to appear and in which the stereo effect of the 7800 has the most impact.

The two tracks may be played back individually or as a stereo pair depending on the position of a front panel switch (the precise mode is indicated by one of three LEDs). This allows a great deal of flexibility and, for example, enables any future bilingual tapes to be enjoyed on any video recorder.

The input sockets for both sound tracks are concealed behind a front panel flap and provide inputs suitable for both line (phono) and mic (standard jack) level signals. The outputs are made available on the rear panel via two phono sockets and the AV socket referred to above.

The sound recording circuitry of the 7800 is also notable in that it incorporates two forms of noise reduction system. Some form of noise reduction is almost an essential in a video recorder and the Dolby B system has started to make an appearance on some machines. The 7800 goes one better and offers not only Dolby B but, in addition, Dolby C. This, the latest Dolby system, offers slightly more noise reduction than the familiar B circuit. The 7800 boasts an audio S/N ratio of greater than 55dB with the C system active.

There is not much pre-recorded material using Dolby C at the moment, hence the provision of B in tandem, but any home recording made with the C format will produce an excellent audio track.

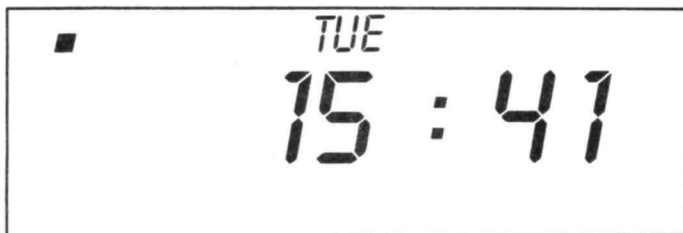

The 'normal' clock display.

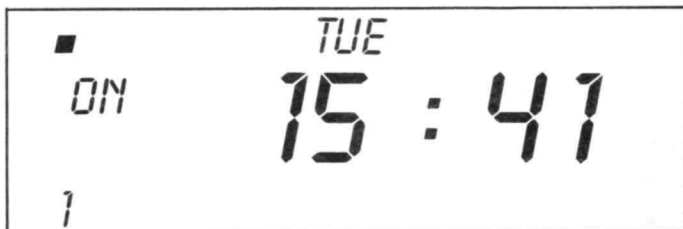

The 'on time' prompt. 'Time now' is displayed as the starting point.



The 'stop time' prompt. Start time is now displayed as the base.

About the only thing not covered so far is the timer section. This is of a four event, fourteen day specification and, in keeping with the other controls of the 7800, is well thought out and easy to use.

After moving a front panel slide switch from its normal to timer position the day is advanced and then, after selecting 'on time' the time at which recording is to begin is entered by incrementing hours (up or down) and minutes (again + and - buttons). The start time displayed initially is 'present time' a good idea as many programs are entered earlier in the day on which they are to be recorded. Using current time as the base, and adding to this is preferable to starting from, say, 00:00. Selecting 'stop' will now display the start time as a base to which the required duration of program can be added.

The final step in the programming sequence is to enter the channel to be recorded.

Moving the slide switch to the normal position will display the current time, in this position the program button will display the current state of the timer memories.

End of Story

The 7800 is then a machine that packs in just about every facility to be found in a video recorder yet maintains an elegant and straightforward to use machine.

The picture quality matches that of most VHS machines and the provision of Dolby C means that the audio quality is excellent. The comprehensive range of trick video effects plus the versatile input/output connections should make the machine ideal for the more adventurous video person.

It's near the top of the price range of recorders and whether the stereo capability and more esoteric of the trick video functions will justify the price is very much a matter of opinion. ■ R&EW

YOUR REACTIONS			
	Good	Average	Poor
Circle No.	28	29	30

MANUFACTURERS SPECIFICATIONS	
Input Level:	Video: VIDEO IN 1.0 Vp-p 75 ohm unbalanced AUDIO: MIC IN -70 dB more than 3.9 kohm unbalanced LINE IN -20 dB more than 50 kohm unbalanced
Output Level:	Video: VIDEO OUT 1.0 Vp-p 75 ohm unbalanced Audio: LINE OUT -6 dB less than 1 kohm unbalanced
AV jack connections:	1 12V during playback, otherwise OV. 2 Video signal (output and input) 3 Ground 4 Audio signal CH1 (output and input) 5 No connection 6 Audio signal CH2 (output and input)
Video Horizontal Resolution:	Colour. more than 240 lines
Audio Frequency Response:	80Hz - 10kHz
Signal-to-Noise Ratio:	Video; more than 43 dB Audio; more than 43 dB (Dolby NR OUT) more than 55 dB (Dolby-C NR IN)



READERS LETTERS

Facts and opinions; Yours and Ours

Registered Letter

The last word column in our October issue has prompted this story from one of our readers with an intimate knowledge of cash dispenser machines.

Dear R&EW

I may have only received the October issue of R&EW today from the Subs Dept, but no doubt you're already working on the December issue.

Your 'Beat the Monster' escapade with Bank Cash Dispensers - not liking your personal code number - really made me laugh; for which reason I shall enlighten you.

Working for one of the banks, it is my 'pleasure' to have to ensure the machine (usually an NCR 1780 or some such like) is working, cash-wise and if not get the NCR engineers out.

Today is this morning however, one particular breed of customer, whom we presume to be of the 'go homus punkus' variety, decided that the machine preferred a diet of milk bottle tops, lolly sticks and pen-knife blade(broken), as opposed to the usual plastic-card brunch. This is not so.

This, of course, resulted in getting the bloody thing racked out for service, thus leaving the wall cavity completely empty. Now this leaves (from the pavement side) a set of buttons and a card slot, but no vandal screen, no CRT and no cash machine. We usually find a 'temporarily out of service' notice plastered to the front sufficient deterrent to any determined, but cashless, customer. Not so. Regardless of all this (and 'real' cashiers inside the branch) TWO cards came tinkling through the wall to land at our feet, with no machine in sight! I could make reference to 'dumb sheep' but we bankers do try to look after our 'flock'. The first card caused hilarity, the second card caused amusement; and the customer screaming through the door for his card back caused absolute shock! His explanation was just as mind-blowing but 2 minutes later, he had his cash!

ARK

Cheltenham

Praise Indeed

Dear Sir,

Having purchased my first issue of R&EW, I would like to say that it appears to be by far the most varied and interesting electronics magazine on the market.

The multistandard FM TV sound IF design by Graham Leighton in the September editions Circuit Blocks was of particular interest, although obtaining 2K241 Toko coils is presenting a minor problem.

Anyhow, keep up the good work, I'm looking forward to the next issue.

BGJ

Bristol

Well, thanks for the comments - we do appreciate receiving letters of praise (from our more discerning readers), as well as those relating problems with projects.

Regarding the 2K241 coil, for the September Circuit Blocks, you can find it in the latest Ambient catalogue (code no 35-02411) under the full reference number 113KN2K241DC. In fact, most of the components featured in R&EW projects are listed by the better component suppliers.

Head and Shoulders

Dear Sir,

I do not make a habit of writing to magazines - but in this case I'm afraid I've been compelled to. Having built the ZX81 expansion board from the August '82 issue of R&EW, I found (to my horror) that the pin connections were in a right old mess (literally). Now, although I am quite used to disentangling circuits from electronics magazines (though, I must say, you have been OK in the past), I would appreciate some help with this particular example.

I have been reading R&EW since the first edition and have found it to be head and shoulders above the other so-called electronics hobbyists magazines. I therefore hope you can keep up the good record and inform me of the errors in the expansion board article.

CRP

Essex.

Quite a few letters have been received concerning the expansion board - so we decided to put the

record straight and publish the revised pin connections. We apologise to all those readers who've had problems with this project and will be enclosing a copy of the errata with our kits.

Pin No.	Function	Pin No.	Function
1	9V	16	A10
2	0V	17	A1
3	MREQ	18	A0
4	A11	19	RD
5	A12	20	RAMCS
6	A13	21	0V
7	A14	22	D7
8	A7	23	D6
9	A6	24	D5
10	A8	25	D4
11	A5	26	D3
12	A9	27	D2
13	A4	28	D1
14	A3	29	D0
15	A2	30	WR

Note: RAMCS, chip select was misprinted as C3.

PH Meter

In the March 1982 issue of R&EW you included construction details for a digital PH Meter; though I have not noticed any advertisement for a parts kit in later issues.

Would you please advise whether a kit is available and, if so, the cost thereof which would not presumably include the probe. You might also indicate the airmail postage to Australia.

H. Hendriks

Australia

R&EW:

This letter was received at our offices but the writer, had omitted any form of reply paid envelope for our reply. A common occurrence and once again we must stress that we cannot reply to letters unless the return postage is prepaid.

The answer in this case is that the PH meter is not available as a complete kit but, as the components are fairly standard, they should be available from most mail order companies. The PCB is available from our PCB service, see the advert in this issue.

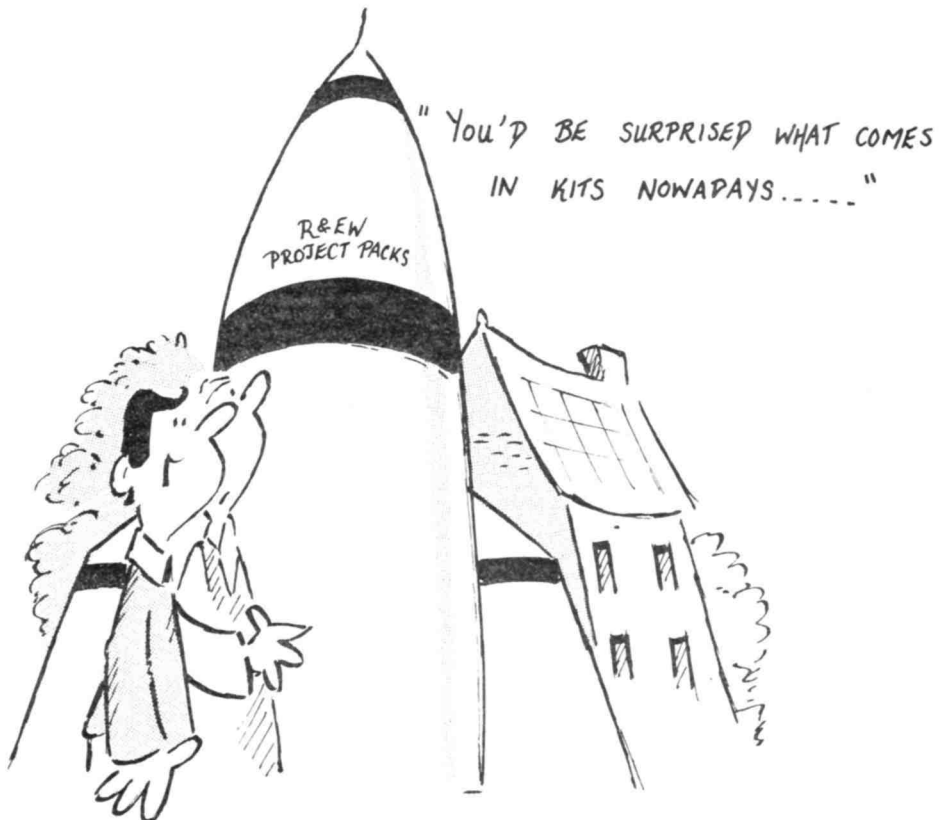

THE CENTRE

LONDON'S NEWEST AND BRIGHTEST EMPORIUM
**10 MERTON PARK PARADE,
 KINGSTON RD.,
 LONDON SW19**
TEL: 543 5150

We are open till 8 pm Wednesdays
**ACCESS - BARCLAYCARD
 INSTANT CREDIT THROUGH
 TRICITY FINANCE**

NEW AND SECOND HAND EQUIPMENT ALL FULLY GUARANTEED

**YAESU - ICOM - SOMMERKAMP
 STANDARD - TRIO - AZDEN - FDK**
 Full range of Mobile/Base Antennas by G
 Whip - Jaybeam - S.M.C.

*Poles - Lashing Kits - Cable - Rotators
 - Plugs and Sockets*

STOP PRESS

THE NEW G4HXZ MORSE TAPE

15 MINS LETTERS 5 WPM
 15 MINS NUMBERS 5 WPM
 15 MINS MIXED 10 WPM
 15 MINS LETTERS 15 WPM

£1.75
inc. P+P

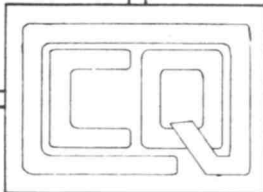

2 METRE SLIM JIM

We can now supply this antenna by Mail Order at **£8.50** with 4 metres of co-ax (inc. post & package). The cheapest antenna in the business.

HB9-CV COMPACT 2 EL. BEAM

4.5dB gain, 18dB front to back. **£8.50** (with clamp) *now available.*

Also in 70cms version (same gain)

N.B. We regret we cannot supply the 2 metre version on Mail Order as it is too long to go by post.
Please allow up to 28 days for Delivery

DEALERS FOUND GUILTY!

The CQ Centre in Merton Park were recently found guilty of paying excessive prices for second-hand radio equipment. Roads in the district were totally jammed as eager customers flocked in to take advantage of the generous prices being offered. A spokesman for the company would only comment that this was a firm policy and would be continued in the future. Further investigations revealed that there was a sale or return service in operation for which the charges are only 10%. It was also found that copious amounts of tea and coffee were being served on the premises.

174 for further details

NO!

If you see an advertisement in the press, in print, on posters or a cinema commercial which you find unacceptable, write to us at the address below. (TV and radio commercials are dealt with by the I.B.A.)

**The Advertising
 Standards Authority.** 

ASA Ltd., Brook House, Torrington Place, London WC1E 7HN.

6 inputs... 6 colours... words too

You'll never need overprinted or special chart paper again.

- Disposable six pen dotting head records in six different colours on 4" (100 mm) chart ... prints time, day number, chart speed, scales and other data in plain language.

- Up to three different linearising signal conditioners (each assignable to any of the six inputs) for all known T/C's, RTD's, d/p cells and other non-linear signals.

- Printing of two alarm set points appears as regularly-spaced pairs of colour-keyed dots.

Southdownview Road
 Worthing, Sussex.

Tel: Worthing
 (0903) 205222

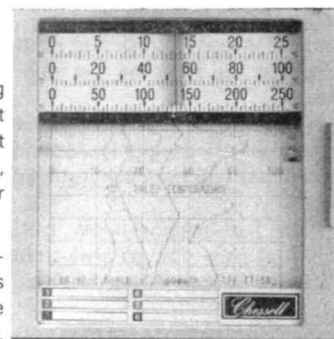

Model 306 Multipoint

EI *Chessell Ltd*

175 for further details

SOUNDING OFF

Evan Steadman's explanation for the poor state of the T&M market at present – plus, as a special bonus, his 'get rich quick' scheme.

So where did all the multimeter orders go?

Digital or analogue, heapo-cheapo or pouff-la

Ditto, for that matter, the demand for low-cost "scopes?"

Well, I'll tell thee.

When a big employer of engineers gets its numbers in a twist, lots of them have to go. Which, once they've been rendered redundant, means there's a pile of T&M equipment beached on the bench.

So, if anyone else wants an AVO, they jolly well have to get one of those festering over there.

Now, lots of manufacturers have tried to keep market share by producing new models with additional functions or facilities. But haven't got away with it because, in this current climate, their employers are saying horse manure to anyone trying to purchase anything but the barest necessities – unless it can be proved that it will really save money in months to come.

And the net result is that the low-cost, less 'valued-added' instruments are not the industry glamour pussies just at the moment.

Not, for that matter, that the industry as a whole is doing very much. It really is a shame that our leaders are so tardy and lassitudinous as to allow a policy blue-print for the long-term survival of the electronics industry to be published by the National Economics Development Council and then make no formal moves to implement the Council's proposals. It must be as clear as day that national policy should be the provision of venture capital for lots and lots of small, thrusting outfits; and a careful assessment of grant-aided R&D within the giant companies. And I'm not spouting politics – just economics.

Are You Still With Me?

So I popped out and had a quick look at the biggest electronics companies in Europe. In the first 10 we only managed to boast GEC, and they rank 5; but with half the sales of No. 4, Thomson Brandt, over there in France.

I have also got to tell you that the excellent Mackintosh Research outfit has computed that, of the hundred largest electronics manufacturers operating in Europe, almost one third of them are American.

And the sales of British and French companies (electronics only) were about the same as just one Dutch company – Philips, of course.

Now you know that there's this recession going on – and that things are pretty groggy in America? Well, the average American company has still been generating double the profits of our British chappies.

I'm not Brit-bashing today, but you ought to know where you stand. And how you go about changing all this – to lead all we Angles and Saxons into a brighter future.

**And Now Get Rich Quick –
The Evan Steadman Way.**

It seems almost incredible that the highest rate of growth in unemployment today is fastest among the hitech industries.

So much for the future, I hear you cry.

But stay. In truth you chaps are in a gorgeous position to strike it rich, and I'm going to tell you how.

In Sunny Saffron Walden

My office uses photocopying and telex facilities in its headquarters block, which is stuck up a grotty arcade in what is hardly the most bustling commercial centre of the free world.

Getting cross about the cost of photocopying, etc, I resolved one day to offer a straight-off-the-street service for 12½p a full page, and an instant-telex-to-anywhere facility for howsoevermuch a word to subsidise my own overheads.

Last year I made £6,000 profit on this service!

In Saffron Walden!!

And in offices next to a fish and chip shop!!

Now I know that £6K is not enough to support you wealthy blokes if the great redundancer in the sky should look your way, but what if one had an off-the-street Apple computer sitting beside the photocopier and telex?

So that, for example, a little old lady could have a floppy with her Christmas card list on it; or little old sweet shop proprietor could have his floppy with, say; a monthly print-out of debtors undertaken on a regular basis.

Since it is inevitable that Joe or Josephine Average will want to use computers but will not have the nous to operate them, such a facility is the next logical development to the instant printing shops that have girded the earth in about five years flat.

Use Your Company's Time

What you must do is get more and more into mini computers or micros – or whatever size seems most appropriate – at your place of work.

Show willing (which may, incidentally, save you from being made redundant anyway).

Once you know how to run the Apple of your eye, you're ready to set-up in business.

In the cheapest little shop in your home town; because, if you offer a unique service, society will seek you out.

It will only be a matter of time before your basic computer operation will become much admired by the local businessmen who don't want to have to hire their own personnel and worry about whether they should have bought an IBM mainframe. They'll use you more and more.

And so, having now got a computer bureau going, you will start spending some of your profits installing fax machines, colour photocopiers – if they ever get them right – and the like.

Now I'm not being frivolous about all this because I make £6K a year in, may I state once more, Saffron Walden – which has a population of 27 and about 3 active businessmen.

I hope you will concede that the outline I have given you above is within the reach of any reader of a publication as abstruse as this one.

One last point: the fact that the above is a piece of cake only underlines the inevitability of the trend toward service industries and away from manufacturing.

When robotics really take-off in 20 years' time, the only job worth having in a factory will be oil-can lady.

Now don't write to thank me for this truly generous dollop of career guidance; and don't come to see how I do it in Saffron Walden – unless you actually want some copying done.

I have only recently hired young Sonya to operate my Apple, and we are not ready to offer it to the High Street yet.

But, if my secretary remembers to remind me in a year's time, I'll tell you how we've got on.

If, that is, she hasn't been replaced by a word processor . . .

NOTES FROM THE PAST

Centre Tap's column, from the August 1950 issue of *Radio Constructor*, harks back to the early days of the RSGB Exhibition, as well as revealing how the movie industry saw its future over 30 years ago.

No doubt readers interested in the fourth Annual RSGB Exhibition will look elsewhere for detailed reports. Possibly I have had a surfeit of Radio Exhibitions and become a little blasé. They are almost invariably repetitions of what they had last time. This is, of course, unavoidable, but as Exhibitions their primary appeal is to the newcomer to the hobby, and what to the old timer has become almost a repeat performance is to him a great event.

With the RSGB show the old-timers are always well in evidence. They go to see each other rather than the exhibits, unless there are some startling novelties. In this way, I enjoyed myself immensely, but there were also quite a few items I found to be of especial interest.

Happily, I don't have to report on the Exhibition. Perhaps I am getting past the stage where I could warm up with the requisite enthusiasm. Perhaps, too, I see things too much from behind the scenes to adequately share the effect on those who view it from the stalls.

And the high-spots? Well, I had no end of fun playing with the Reaction Timer on the GPO Stand. It's nothing to do with tickler coils; it's just a device to measure how quickly one responds to a visual signal. Any friends I have left will be pleased to know that I am still a shade quicker than the average. In case some of those present did not believe it I took them across with me to prove it. It's nice to be able to show people how good you are at something – but it doesn't make them any friendlier!

The device consists of a meter, the slow-moving needle of which is arrested as soon as you press the "Stop" button after being warned by a flashing light. A rough model could be knocked up at home, when you can find out for yourselves just how easy it is to become thoroughly unpopular if you happen to be good at it.

The Other Fellow

It is odd how often the phrase "average reader" occurs whenever readers discuss or write about *Radio Constructor*. Yet when we reduce it to cold logic we find there is no such person as an average reader. If, for instance we find that most readers like *Notes from the Past*, we might still find that the reader who is nearly average in all other respects will tell you that it gives him a pain in the neck.

Perhaps it is because we all like to think of ourselves as being ordinary sorts of blokes that we come to believe that everyone else who has got any sense ought to enjoy the things we like and to equally dislike our pet aversions. Even if they spoke of "everyone like me" instead of an average reader it is still doubtful that we should properly recognise that there are probably no two readers with quite the same ideas and tastes.

I suppose each of us has often speculated, if the opportunity came our way, on what we should do to improve our favourite magazines. Maybe after careful thought the reader writes to the Editor offering suggestions.

Although he may notice no apparent effect, his fear that he has wasted his time is groundless. Firstly, it helps the Editorial staff to take a balanced view of a still wider range of readers, and secondly, it prevents a magazine from becoming stereotyped.

No doubt most readers will have noticed that many technical journals run to a pattern and their range of subjects seem to settle in a rut. The best of Staff-writers are liable to stick to a supposedly successful formula, and outside contributors submit only articles based on the same pattern as those regularly appearing, thinking

them to be more acceptable.

Those who have sent criticism, comments on the arrangement, praise or views on the proportions of technical/constructional/theory/general articles, can at least be assured that their opinions do help to sway the trend to future issues.

Futurist

Some readers may have been to the "cinema-of-the future" at the Festival of Britain Exhibition, and formed their own ideas about the stereoscopic picture and ventriloquial sound effects. The three dimensional picture is certainly vivid, especially when accompanied by "three-dimensional" sound.

For the stereoscopic vision, obtained by two overlapping pictures, special spectacles have to be worn. The idea is quite old. Stereoscopic film projection on the same principle was used well before the first World War, but it still suffers from the limitation of special spectacle wearing. Once the novelty has worn off the strain is quite noticeable.

The accompanying sound-dubbed "stereophonic" – is still more effective. It is also a greater technical feat. The sound comes in turn from 24 loud speakers hidden behind the screen, at the sides of the proscenium, in the roof etc.

In this way, the sound can follow the players as they move across the screen to add to the realism.

Frankly, I do not think stereoscopic pictures in this form will have any marked influence on the cinema, but stereophonic sound has far more promise once the difficulties have been ironed out. It is no easy task to automatically select which of a bank of speakers is to take a given passage of sound, and then to change it as the source of the sound moves across the screen.

"Take Your Corners . . ."

Stereoscopic sound is, of course, no novelty. The drawback is that it needs manual operation.

Strangely enough, its first effective use in my experience was some years ago by a schoolboy – with my amplifier. Originally built as a modulator in rack and panel form, I changed the output transformer of the amplifier when I loaned it to a local club for use at their weekly club dances.

Three speakers were wired in. Two in the hall which was used as a dance floor, and one in a recreation-cum-refreshment room. A separate fader was arranged on a control panel beside the amplifier to control the speaker in the refreshment room.

The son of the M.C. on his own initiative brought the refreshment room speaker back into the hall, positioning it at the far end. He had learned a couple of old-time dance records off by heart – the type where the M.C. calls instructions about the dance formations. At each point where the voice broke in, he faded down the two main loud-speakers and turned up the gain on the one at the far end.

The effect was momentarily uncanny – the voice coming from a different direction seemed quite independent of the record. The music level, of course, was about the same but the effect of its being subjective to the voice was quite marked. From the dance floor the first impression that the announcements were from a "live" M.C. actually in the hall, or at least quite distinct from the record, was quite startling.

R&EW BOOK SERVICE

Use the reply paid coupon for ordering.

COMPUTING IS EASY

By D Parker & M Hann
1982; 113pp; 155 x 230mm; Paperback;
Publisher, Butterworths; ISBN 0-408-
01203-X.

Stock No: 02-01203 Price: 4.45

This book is not concerned with the electronics that make a computer function but with **how to use** computers. It is primarily intended for the fast-growing number of school children who have access to personal microcomputers at home or at school.

Essentially, the beginner is introduced to the computer and encouraged to explore its capabilities, by means of carefully prepared programs and experiments using the BASIC programming language.

Commencing with a chapter on using the computer as a calculator, the reader is shown how to institute simple programs and computer keywords are clearly explained as they arise. The final chapters conclude with useful routines, debugging programs and exercises, and six more complicated programs. In the appendices there are suggested solutions to problems set in the final programs, variations and tips on BASIC, suggestions for further reading and a glossary.

The text is easy to follow, well illustrated by apt and amusing cartoons and is suitable for all beginners.

BASIC FOR HOME COMPUTERS

By B Albrecht et al
1978; 334pp; 170 x 255mm; Paperback;
Publisher, Wiley; ISBN 0-471-03204-2.

Stock No: 02-32042 Price: 7.25

This book shows you how to read, write, and understand MICROSOFT BASIC, the programming language used in the PET, APPLE, TRS-80, and other personal-size microcomputers. In just a few days you can learn to do nearly anything you want using BASIC programs - without any special background or access to a computer.

It gently leads readers through the fundamentals of programming. In introducing increasingly sophisticated concepts, it is careful to reinforce the relevant preliminaries, and takes you from knowing almost nothing to knowing almost everything about BASIC.

ELEMENTS OF BASIC

By R Lewis & B H Blakeley (NCC)
1972; 202pp; 150 x 210mm; Paperback;
Publisher, NCC (W); ISBN 0-85012-118-3.
Stock No: 02-21183 Price: 10.50

The BASIC language has been developed as a language particularly attractive in the teaching environment and for the newcomer to computing.

This book introduces the language, covering the mathematical, non-numeric and data-processing facilities. Where possible the text is machine-independent although supplements are included to show variations in a number of

manufacturer's implementations. The book is suitable for use in schools and colleges and is also appropriate for self-study by anyone wishing to become familiar with the language.

ATARI SOUND AND GRAPHICS

By H Moore et al
1982; 234pp; 170 x 255mm; Paperback;
Publisher, Wiley; ISBN 0-471-09593-1.

Stock No: 02-95931 Price: 7.25

This crystal-clear guide is the first book to open up the vast creative possibilities of artistic programming to owners of the ATARI 400 and ATARI 800 - the most visually advanced personal micros on the market. With this self-paced, self-teaching guide, you'll advance step-by-step through simple techniques for creating a fascinating array of sounds and images.

As a beginner with no computing experience, this guide lets you see and hear things on your ATARI right away. It enables you to learn to compose and play melodies, draw cartoons, create sound effects and games, and progress to more sophisticated artistic programming, and because the book uses BASIC and requires no programming knowledge, you learn elementary BASIC programming in the context of each newly introduced technique!

DATA FILE PROGRAMMING IN BASIC

By L Finkel & J R Brown (Level: undergrad)
1981; 348pp; 170 x 255mm; Paperback;
Publisher, Wiley; ISBN 0-471-08333-X.

Stock No: 02-08333 Price: 9.25

A step-by-step, self-instructional guide to programming and maintaining data files on microcomputers using BASIC. Shows how to use data files for a variety of home and business applications.

ELECTRONIC FAULT DIAGNOSIS

By G C Loveday
2nd Ed 1982; 110pp; 185 x 245mm;
Paperback; Publisher, Pitman; ISBN 0-273-
01854-X.

Stock No: 02-01854 Price: 5.25

One of the most important skills that an electronics technician can have is the ability to diagnose the **causes of faults** in circuits and electronic equipment. This book is an introduction to the subject which aims to teach the student how to acquire such valuable skills.

After first considering the basics of fault diagnosis, the text mainly concentrates on component faults in particular types of circuit, rather than on the technique required for localising faults in complete electronics systems.

Following the first two chapters, each chapter concludes with a number of exercises with questions based thereon, the answers to which are given at the end of the book. The author states that the majority of the circuits in the book have been built, using readily available components, then measurements made

under fault conditions. The student should construct the circuits as practical projects.

The book is particularly intended for students studying the City and Guilds 224 Electronics Servicing, and appropriate Technical Education Council units.

ACTIVE FILTER DESIGN

By Carson Chen
1982; 134pp; 150 x 225mm; Paperback;
Publisher, Hayden; ISBN 0-8104-0959-3.

Stock No: 02-09593 Price: 8.50

Well, what can you say about this perennially favourite subject? Well, the bad news is that most active thinkers and enthusiasts will not be able to put this book down, without adding it to their collection of active filter reference works.

The good news is that this book outshines the classic Active Filter "cookbook", in the theoretical analysis of the subject, and helps provide a rounder and more thorough treatment of the subject. As the title implies, the book is all about design, and a few more worked examples might be helpful. Still, the indexing is excellent.

GUIDELINES FOR COMPUTER MANAGERS

By National Computing Centre
1981; 266pp; 150 x 215mm; Hardcover;
Publisher, NCC (W); ISBN 0-850-12-248-1.
Stock No: 02-22481 Price: 18.00

Many topics need to be considered by computer managers for the successful implementation and operation of installations. The present Guidelines cover the important areas to which attention should be given. Checklists are included to encourage a systematic approach, and brief bibliographies are appended to each chapter.

Topics covered include: the control of data, selection (of terminals, data preparation methods, programming languages, etc), insurance, dp staff, system efficiency, documentation, contracts, auditing, programming, software, operations management, security, systems implementation, and microcomputers. It is expected that these Guidelines will be useful both to experienced dp managers and to managers newly charged with the task of implementing a computer system.

ADVANCED BASIC: APPLICATIONS AND PROBLEMS

By J S Coan
1976; 192pp; 150 x 230mm; Paperback;
Publisher, Hayden; ISBN 0-8104-5855-1.
Stock No: 02-58551 Price: 10.00

Now you can extend your expertise in the BASIC language with this book of advanced techniques and applications of the BASIC language. It allows you to gradually increase both your understanding of concepts and your ability to write programs. The development of each topic progresses from simple to more sophisticated problems and is accompanied by many sample programs to clarify the discussions.

RADIO BOOKS

AMATEUR ANTENNA TESTS AND MEASUREMENTS by H D Hooton. Stock No: 02-21466	7.95
BEGINNERS HANDBOOK OF AMATEUR RADIO by C Laster. Stock No: 02-02156	10.20
CB RADIO CONSTRUCTION PROJECTS by L Buckwalter. Stock No: 02-20952	3.45
FERROMAGNETIC CORE DESIGN by M F 'Doug' DeMaw. Stock No: 02-40881	20.45
MICROWAVE DEVICES AND CIRCUITS by S Y Liao. Stock No: 02-58120	28.50
RADIO HANDBOOK 22nd Edition. by W I Orr. Stock No: 02-21874	26.70
QUESTIONS & ANSWERS ABOUT CB by L G Sands. Stock No: 02-20893	3.35
TV ANTENNAS AND SIGNAL DISTRIBUTION SYSTEMS by M J Salvati. Stock No: 02-21584	8.70

GENERAL BOOKS

ABC's OF INTEGRATED CIRCUITS by R P Turner. Stock No: 02-21462	4.95
ACTIVE FILTER COOKBOOK by D Lancaster. Stock No: 02-21168	11.70
BASIC ELECTRICITY/ELECTRONICS BOOKS All by Training and Retraining	
VOLUME 2: How AC and DC Circuits Work Stock No: 02-21502	7.95
VOLUME 3: Understanding Electronic Circuits Stock No: 02-21503	7.95
VOLUME 4: Understanding and Using Test Instruments Stock No: 02-21504	7.95
BASIC ELECTRICITY/ELECTRONICS TROUBLE-SHOOTING COURSE by D R Tomal. Stock No: 02-21590	7.95
BUILDING & INSTALLING ELECTRONIC INTRUSION ALARMS New Edition by J E Cunningham. Stock No: 02-21465	8.70
CHEAP VIDEO COOKBOOK by D Lancaster. Stock No: 02-67221	6.45
CMOS COOKBOOK by D Lancaster. Stock No: 02-21398	10.20
COLOUR TV TRAINING MANUAL 4th Edition by H Sams Editorial Staff. Stock No: 02-21412	11.70
COMPLETE GUIDE TO READING SCHEMATIC DIAGRAMS by J Douglas-Young. Stock No: 02-04244	11.70
DESIGN OF ACTIVE FILTERS By H M Berlin. Stock No: 02-21539	8.70
DESIGN OF OP-AMP CIRCUITS, with experiments by H M Berlin. Stock No: 02-21537	8.70
DESIGN OF PHASE LOCKED LOOP CIRCUITS, with experiments by H M Berlin. Stock No: 02-21545	8.70
DESIGN OF VMOS CIRCUITS, with experiments By R T Stone et al. Stock No: 02-21686	9.45
ELECTRONICS TEC LEVEL II 2nd Ed (Pitmans) by D C Green. Stock No: 02-01827	5.45
ELECTRONICS TEC LEVEL III 2nd Ed (Pitmans) by D C Green. Stock No: 02-01831	6.00
ELECTRONICS FOR THE BEGINNER 3rd Edition by J A Stanley. Stock No: 02-21737	7.95

COMPUTER BOOKS

ADVANCED COMPUTER DESIGN by J K Iliffe. Stock No: 02-01125	19.45
APPLESOFT LANGUAGE by B & G Blackwood. Stock No: 02-21811	8.70
ATARI ASSEMBLER by D & K Inman. Stock No: 02-02366	10.05
BASIC PROGRAMMING ON THE BBC MICROCOMPUTER by N & P Cryer. Stock No: 02-06640	6.45
CALCULATOR CLOUT: PROGRAMMING METHODS FOR YOUR PROGRAMMABLE by M D Weir. Stock No: 02-11040	7.65
CIRCUIT DESIGN PROGRAMS FOR TRS-80 by H Berlin. Stock No: 02-21741	11.40

COMPUTER DICTIONARY 3rd Edition by C J Sippl. Stock No: 02-21652	12.45
COMPUTER DICTIONARY & HANDBOOK 3rd Edition by C J & R J Sippl. Stock No: 02-21632	27.20
COMPUTER GRAPHICS PRIMER by M Waite. Stock No: 02-21650	11.70
CP/M PRIMER by S M Murtha & M Waite. Stock No: 02-21791	11.70
CRASH COURSE IN MICROCOMPUTERS by L E Frenzel Jr. Stock No: 02-21634	15.45

TRS-80 INTERFACING BOOKS 1 & 2

If you have a fairly good understanding of the commands in Level II BASIC, Book 1 will appeal to you. The book introduces you to the signal available within the TRS-80 computer and illustrates how they can be used to control external devices. You will have an opportunity to construct and test a number of interesting interface circuits that will be used in the experiments. Book 2 introduces you to more advanced interfacing techniques that allow you to do real things with your TRS-80 computer.

By TITUS et al. Each book 1980. 256pp. Paper.	
Book 1 02-21633	8.70
Book 2 02-21739	9.45

Z-80 MICROCOMPUTER DESIGN PROJECTS

Even a beginner in electronics will enjoy constructing and operating the EZ-80 microcomputer, a project that requires surprisingly little time and money. The book is a solid introduction to the Z-80 microcomputer and the remarkable chip, EZ-80. Several EZ-80 applications programs are included. By W BARDEN Jr. 1980. 208pp. Paperback.

02-21682 11.45

Z-80 MICROCOMPUTER HANDBOOK

This thorough handbook covers hardware, software and microcomputers built around the Z-80.

By W BARDEN. 1978. 304pp. Paperback.

02-21500 9.45

THE 68000 : PRINCIPLES AND PROGRAMMING

A comprehensive introduction to one of the most powerful new 16-bit microprocessors the Motorola 68000, this book assumes a basic understanding of computer architecture and familiarity with some types of assembly language.

By L J SCANLON. 1981. 238pp. Paperback.

02-21853 11.70

16-BIT MICROPROCESSORS

The authors have attempted to reduce the vast complicated documentation available on the many microprocessors into something manageable and at the same time provide a format in which the reader can easily compare the processors.

By TITUS et al. 1981. 350pp. Paperback.

02-21805 11.45

Z-80 MICROPROCESSOR PROGRAMMING & INTERFACING BOOKS 1 & 2

Two volumes of laboratory-orientated text. Book 1 explores Z-80 software and machine language programming. Book 2 addresses interfacing digital circuits with the Z-80 CPU, PIO, and CTC chips. Both books stress learning through experimentation.

By NICHOLS et al. 1979. 304pp/496pp. Paper.

Book 1 02-21609 10.20

Book 2 02-21610 12.45

Z8000 MICROPROCESSOR: A DESIGN HANDBOOK

This volume focuses on the architecture of the Z8001 and Z8002 microprocessors and logic design using the Z8000 family of components. The text includes a detailed discussion of the Z8000 architecture, emphasising the features that determine the hardware interface to the CPU. The book also explains the benefits of particular hardware features to help the reader to learn the reasons behind a particular design approach.

By B K FAWCETT (Zilog Inc.). 1982. 256pp. Paper.

02-37345 13.25

6502 SOFTWARE DESIGN

The 6502 integrated circuit is a very popular microprocessor that is currently being used in general-purpose microcomputers, video games, and personal computers. This material is presented to increase the reader's understanding of the 6502 integrated circuit. Fundamentals are first explained then more complex topics are gradually introduced in the nine information-packed chapters.

By L SCANLON. 1980. 272pp. Paperback.

02-21656 10.20

RAY MARSTON'S 110 SERIES

Written specifically for the home constructor.

110 CMOS DIGITAL IC PROJECTS
02-00216 5.15

110 ELECTRONIC ALARM PROJECTS
02-00269 5.15

110 IC TIMER PROJECTS 02-00480	5.15
110 INTEGRATED CIRCUIT PROJECTS 02-00309	5.15
110 OPERATIONAL AMPLIFIER PROJECTS 02-00153	5.15
110 SEMICONDUCTOR PROJECTS 02-00322	5.15
110 THYRISTOR PROJECTS 02-00074	5.15
110 WAVEFORM GENERATOR PROJECTS 02-00353	5.15

NEW PITMAN BOOKS

ELECTRONICS TEC LEVEL II 2nd Edition By D C Green. 1982. 150 pages. Paperback.	02-01827 5.45
ELECTRONICS TEC LEVEL III 2nd Edition By D C Green. 1982. 206 pages. Paperback.	02-01831 6.00
TRANSMISSION SYSTEMS TEC LEVEL II 2nd Edition By D C Green. 1982. 148 pages. Paperback.	02-01826 5.45

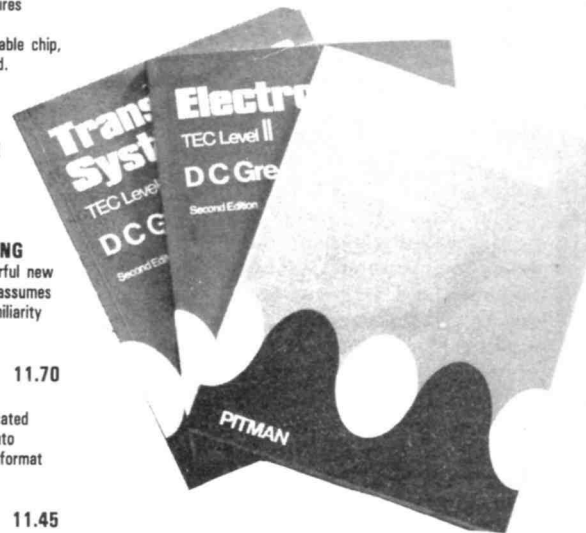

MOTOROLA DATA BOOKS

THE EUROPEAN MASTER SELECTION 1982 Stock No: 02-14000	4.05
LOW POWER SCHOTTKY TTL Stock No: 02-29478	6.15
MOTOROLA LINEAR INTEGRATED CIRCUITS Stock No: 02-08182	7.20
MOTOROLA MEMORY DATA MANUAL Stock No: 02-02168	5.20
THE EUROPEAN CMOS SELECTION Stock No: 02-04000	7.55
MOTOROLA RF DATA MANUAL Stock No: 02-06870	8.05
EUROPEAN HOME ELECTRONICS - INTEGRATED CIRCUITS Stock No: 02-18182	6.05
EUROPEAN HOME ELECTRONICS - DISCRETE DEVICES Stock No: 02-28182	6.05

50p postage is included in the book prices shown. Packing is charged at a flat rate of 60p per order. Make cheques/postal orders payable to R&EW Book Service, 200, North Service Road, Brentwood, Essex CM14 4SG.

DX-TV

Reception Reports

Compiled by Keith Hamer and Garry Smith.

Sporadic-E activity continued well into September despite the predicted drop-off in reception which usually occurs at the beginning of the month. There was no shortage of tropospheric-propagated signals either due to a build-up of high pressure over central Europe which produced a remarkable opening around the middle of September. Signals from the Zimbabwe transmitter at Gwelo on channel E2 were received on several occasions in the UK by a combination of Trans-equatorial skip (TE) and Sporadic-E (SpE). Twice during the month Auroral activity produced signals from across the Atlantic. Having set the scene, let's look at reception in more detail.

The first few days of September produced SpE signals in Band I from the following countries: Russia, Norway, Spain, Poland, Italy and also Switzerland, during the late afternoon. On the 6th there was an intense opening to the south and south-east. At 1710 BST on channel E4 the Yugoslavian test card with "JRT ZGRB 1" identification was noted and with the aerials turned due south a regional Spanish programme was seen on the same channel. From another Spanish transmitter, but on E2, the electronic test card was present. With the aerials re-directed towards the south-east, West German programmes were noted on E2 (48.25MHz vision). At 1758 BST, an identification caption was seen on channel R2 which confirmed reception from TVR-Roumania. The caption was similar to the one shown in September's column. Signals from the USSR were received on R2 and R3 at 1814 which included a female announcer with a digital clock (see R&EW, October).

On the 8th, during the early afternoon, a programme from RTVE/TVE (Spain) was seen on E3 and E4. A little later the Italian PM5544 test card was noted on channel IA carrying the identification "RAI 1". At 1706 a programme was received on E2 which is suspected of originating in Zimbabwe and propagated via a combination of TE and SpE. Yugoslavian transmissions were logged at 1725 on E3 with the "JRT BGRD 1" PM5544 plus a digital clock insert. The French sound channel of TDF was detected on 41.25MHz (channel F2) which probably originated from the TF-1 transmitter at Troyes (250kW) or Caen (50kW erp). Several programmes from TSS (USSR) were noted via SpE on channels R1 and R2 from 1815. Simultaneously on E2, E3 and E4 programme material was received from Spain. Later in the evening (at 1920 BST), a

programme which included a weather forecast was detected on the Band II television channel, IC, which must have come from RTS-Albania.

Reception on the 9th was very limited with only the Italian news programme "Telegiornale" (identified by a "tG1" caption) on IA at 2239, via SpE, plus a programme schedule caption from the French Antenne-2 (TDF-A2) network on channel E21, via improved tropospheric conditions.

Strong video signals were detected on the 12th from TSS at 0929 on channels R1 and R2. In fact the signals were so strong that SECAM colour was noted. An hour later on E2 the Swedish PM5544 test card was seen in PAL colour, possibly from the 100kW outlet at Hoerby. Slightly enhanced trop conditions prevailed to give Band III reception from NOS-Netherlands on channel E5 with the "NOS-NED. 1" PM5544 and Belgium on E10 with their PM5544 carrying the identification "BRT TV 1".

From the 13th, tropospheric conditions improved dramatically throughout the United Kingdom as this month's reception reports graphically indicate. At this particular location, reception via trop was first noted at lunch time with the NOS PPM5544 on channel E4 carrying the identification "NEDERLAND 1". The French-language service operating in Belgium (RTB) was observed on E3 with sample pages from their teletext service. In Band III, the West German service of Norddeutscher Rundfunk was received on channel E10 with the FuBK electronic test card with the inscription "NDR 1". From East Germany came the distinctive "DDR F1" electronic test card on channel E5.

Returning to West Germany, an FuBK test card was noted from the channel E9

Langenberg transmitter (100kW erp) with the identification "WDR 1 LA9". Later in the day the second network of Radio Telefis Eireann was noted on channel IJ with the "RTE 2" PM5544.

The good tropospheric conditions continued on the 14th, thanks to an anticyclone of 1027mbs centred over northern France. Reception was first encountered at 0729 from West Germany with an identification caption indicating "wdr Westdeutcher Fernsehen". At 0731 on channel E29 the old monochrome EBU Bar was seen from NOS and then at 0732 a rare UHF visitor to this location was sighted on channel E31. It was the PM5544 test card from the second network of Swedish television with the identification "TV2 SVERIGE". Good quality colour was resolved as well as from the first network transmission on channel E9. The tropospheric conditions caused SR-Sweden to be received in Band I on channel E3. At 0748 schools' programmes from DDR:F (East Germany) were noted on E34 whilst the DDR:F 1 test card was received in Band III on channels E6 and E11. The trop conditions were sustained for the entire day with exceptionally strong signals from Sweden, the Netherlands, East Germany, West Germany, Norway and Denmark. Programmes from the Netherlands included commercials featuring the antics of Loeki the Lion; this character's comical capers link most of the advertisements. From West Germany (ARD) came a dubbed version of Dallas at 2057 on channel E11. At 2151 on E11 the weather forecast from NRK-Norway was noted—quite a lengthy affair! From DR-Denmark came the News programme called "tv avisen" on E5 and E10 at 2205. Exceptionally strong colour signals from RTB-Belgium were noted at 2210BST on channel E8 with the close down lock caption followed by the PM5544 with the identification "WAVRE CANAL 8 RTBF 1". The last signal to be noted on the 14th was a station identification caption from ZDF-West Germany reading "ZDF Hamburg Kanal 30" at 2321.

Trop reception continued on the 15th but on a much reduced scale. Countries received included Sweden, East Germany, Belgium and West Germany, the latter radiating an FuBK test card on E11 with the inscription "WDR 1 TW 11" which identified the transmitter as the 100kW

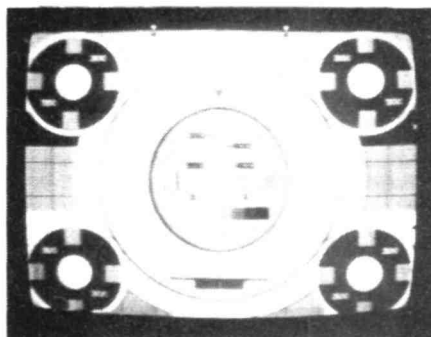

Figure 1: The old Swedish monochrome test card received during September from the 1000kW transmitter at Naessjoe.



Figure 2: The Sveriges Radio colour monoscopic test card which replaced the type shown in Fig. 1

outlet at Teutoburger Wald. Apart from trop reception. TVE-Spain was noted on E3 via Sporadic-E with a teletext transmission called "Teletexto", French television sound was also detected on channel F4 (54.40MHz).

More SpE activity was noted on the 16th with Poland (TVP) radiating the "TP 1" clock caption on R1. Czechoslovakia (CST) appeared on the same channel with the "RS-KH" electronic test card.

The next highlight of the month came on the 26th at 1735. Intense Auroral Reflection (AR) activity caused severe interference to both audio and video on channels E2,R1,IA,E3,R2, E4,A2,A3,A4 and even as high as some Band III channels. At 1752 the AR activity resulted in the American A2 sound channel being resolved with a programme from the USA or Canada.

Reception from the E2 transmitter at Gwelo (ZTV-Zimbabwe) was noted on the 28th via TE/SpE at 1728 and the month of September ended with the PM5544 carrying the identification "RUV ISLAND" on channel E4 at 2320BST which confirmed reception from Iceland.

All-in-all, the month was most interesting especially considering that September is normally very quiet as far as DX-TV is concerned.

Featured Fortunes

Cyril Willis has been busy at his home in Little Downham (Cams.) with Sporadic-E, Tropospheric, Auroral Reflection and F2 reception. His log for September is as follows:-

- 1/9/82 NRK (Norway) channels E2 and E3 (SpE)
- 2/9/82 TVE (Spain) E2,E3 and E4 (SpE)
- 3/9/82 Unidentified programmes on E3 via SpE
- 4/9/82 TVE E2,E3,E4; RAI (Italy) IA (all via SpE)
- 6/9/82 RAI IA; JRT (Yugoslavia)E3, E4; TVR (Roumania) R2, R3; ORF (Austria) E2a (all via SpE) ZTV (Zimbabwe) E2 (via TE/SpE); Auroral activity noted from the north
- 7/9/82 RAI IA, ZTV E2 at 1040 and 1150 BST
- 8/9/82 TSS (USSR) R1; TVE E2, E3, E4; RAI IA; MTV (Hungary) R1; JRT E3 (SpE); ZTV E2 (TE/SpE)
- 9/9/82 SR (Sweden) E2 (via SpE)

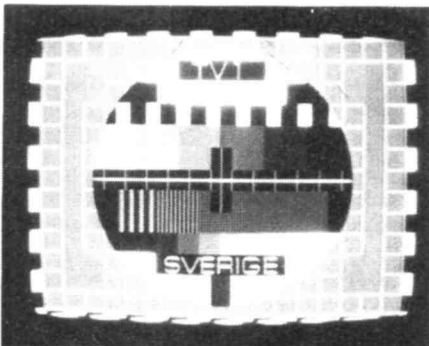

Figure 3: The current Swedish PM5544 test card.

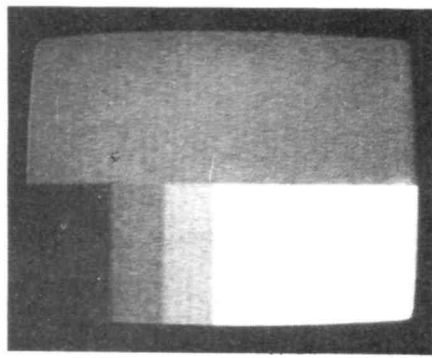

Figure 4: A mystery test pattern received last July on channel E3. It is suspected of originating in Yugoslavia.

- 10/9/82 TVE E2, E3, E4 (SpE)
- 11/9/82 DR (Denmark) E7; ARD/ZDF (West Germany) E21,30,35,39,43,32,33,37, 40,42 and E9; American Forces network at Shape (AFN) E34.
- 12/9/82 DDR:F (East Germany) E34; SR E2,E3,E4; NRK (Norway) E2,E3
- 13/9/82 DDR:F E6,E34; RTE (Eire) IH,IJ,ARD/ZDF E11,10,6,28,29,30,33, 34,35,37 and E53
- 14/9/82 RAI IA; TVE E2, E3; SR E2; TSS R1; MTV R1; ARD and ZDF on many channels due to trop; DDR:F E6, E34; SR E6, 8,9,10,11,E3,E30,32,42,51,48,49; NRK E9; DR E3, E7, E8
- 15/9/82 BFBS (British Forces Broadcasting Service in West Germany) E41,E48; DDR:F E3,E4,E11;NRK E7,E9; unidentified programme on R9 at 0715; SR E2,E3; ARD E2; DR E7, MTV R1; possible reception of the TSS test card on R8, ORF E2a; RAI IA, IB; JRT E3; TVE E3,E4; SRG (Switzerland) E2
- 16/9/82 TSS R1,R2; TVP (Poland) R1,R2;RAI IA;CST (Czechoslovakia) R1; many West German stations; SR E30; BFBS E48; also received were amateur television stations in the Netherlands
- 21/9/82 TVE E3
- 26/9/82 Auroral Reflection (AR) activity noted on E2, E3 and E4 with possible American channel A2 and A3 reception; RTE IB (from Gort)
- 30/9/82 RUV (Iceland) E4 via Sporadic-E

Reception Reports

Clive Athowe (Blofield, Norfolk) has sent us a lengthy log report this month and a few photographic examples of recent reception. Very few European transmissions escaped Clive's aerials on the 14th and 15th. Late evening reception produced Austrian second-network programmes followed by the close down sequence (showing the national flag) at 2344 BST. Reception was from the Pfaender and Gaisberg transmitters on channels E24 and E32. Whilst searching through Band III, Clive noticed a very weak news programme on E11 between 2339 and 2349. To one side of the newsreader was a circle with the inscription "rtz" inside which there was a symbol used by Radiotelevizija Zagreb. The signal faded but returned at 0006 with

a colour bar pattern. This is the first time that a Yugoslavian Band III transmitter has been received in the UK by tropospheric propagation. From 0600 on the 15th, Band III was literally crammed with OIRT (Eastern-bloc) signals although enthusiasts further inland found that conditions had deteriorated. Clive's log for tropospheric reception on the 15th is as follows:- USSR (TSS):Band III channels R7, R8, R9, R10 (two stations) and R12 with a female announcer

USSR (TSS): UHF channels R29 and R32, possibly the transmitters located at Klaipeda and Kaliningrad. Both channels were transmitting a cartoon Poland (TVP-1): Band III channel R10 with the PM5544 test card and a clock caption from Gdansk

Denmark (DR): Band III channels E5, E6, E7, E8 and E10 using the PM5544 East Germany (DDR:F1): Band III channels E8 and E10 on electronic test card from Marlow and Schwerin

East Germany (DDR:F2): UHF channels E29 and E34 radiating the test card Sweden (SR-1): Band III channels E6, E9, E10 and E11, Band I channels E2 and E3 radiating the "TV 1 SVERIGE" PM5544, also UHF channels E33, E40 and E43

Sweden (SR-2): UHF channels E27, E28, E30 with the "TV2 SVERIGE" PM5544, but channel E22 radiating the old monochrome monoscopic test card with transmitter identification

Switzerland (SRG + TSI): German-language network on E31 and the Italian-language network on E34, both from the La Dole transmitter.

Norway (NRK): Band I channel E2 (Greipstad); Band III E7 (Hovdefjell), E9 (Lyngdal), E10 (Skien) and E11 (Halden) all radiating the PM5544 with appropriate transmitter identification

West Germany (ARD and ZDF): Many Band III and UHF channels received, too numerous to list!

The reception of the Swedish monochrome test card was something of a rare event since the older test cards are radiated only for special regional test transmissions or when the main studio links fail. This particular test card was used during the sixties until a modified version, suitable for colour transmissions, replaced it. This later test card was also distinguished by large black corner circles. The current PM5544 electronically generated test card was introduced during 1972-73.

Last July, Clive received a mystery test pattern on channel E3 (see Fig. 4) from the south-east. Such clear reception suggests a single-hop Sporadic-E signal. It is thought by some enthusiasts to have originated in Yugoslavia. Does anyone else think otherwise?

■ R&EW

YOUR REACTIONS	Circle No.
Good	13
Average	14
Poor	15

SHORT WAVE NEWS FOR DX LISTENERS

Frank A. Baldwin

All times in GMT, *italic figures* indicate the frequency in kHz.

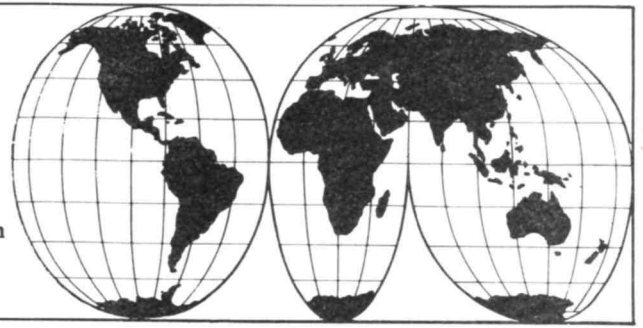

In the last issue mention was made of some of the Indonesian stations that could be logged on the LF bands. In this issue is presented some further details of such transmitters.

RRI Ambon operates on *4845*, the best chance of hearing this one would be around 2300 – if it is not covered by Radio Malaysia, Kuala Lumpur on the same channel!

Then there is RRI Fakfak on *4789*, the first part of their schedule being from 2030 to 2315. The power is only 1kW and I wish you luck with this one.

Then tune in RRI Bukittingi operating on *4910*, listen for the opening at 2300 and the closing at 1600. Although the power is only 1kW, this one has been logged many times in the past few years.

Or what about the *4927* channel, on which can often be heard signals from RRI Jambi in Sumatra. The power is 7.5kW and if conditions are right for Indonesia and the Far East this one will come pounding in.

Or you could try the nearby frequency of *4932* where, if your luck holds, you may also log RRI (Radio Republik Indonesia) Surakarta in Java which, with its 10kW power operates from 1000 through to 1700. Listen from around 1530 onwards.

Further up the scale, on *4955*, is the Sumatran RRI Banda Aceh from where signals can often be heard during its opening and closing periods. Listen at 2300 and also at 1530 – it closes at 1600. The power is 10kW.

Away past MSF will be found the Java based RRI Yogyakarta on the *5046* channel, often coming through quite well with its 20kW power. This one opens at 2300 and closes at 1700 so if you are gunning for this one tune in just prior to those times.

Tune up higher to *5886* and you may find RRI Pekanbaru which opens up at 2230 and closes down at 1600. Sumatran based, it has a power of 10kW.

Good luck with your Indonesian Quest.

Around the Dial

In which we report some of the stations recently logged which should prove of interest both to the short wave listener and the Dixer.

Hungary

Budapest on *8335* at 2000, interval signal (trumpet fanfare), OM with station identification and then the Hungarian transmission for Europe, timed from 2000 to 2030.

Switzerland

Berne on *9535* at 1904, OM with the German programme for both Europe and Africa, scheduled from 1845 to 1930 on this channel. Also logged here at 1315, YL (Young Lady = female announcer) with station identification and announced target areas as Europe, North America, South and South East Asia and the Far East. A newscast of both Swiss and world events followed, all in the English programme timed from 1315 to 1345.

East Germany

“Radio Berlin International”, Berlin on *9730* at 1907, YL with the programme in Italian, scheduled on this channel from 1900 to 1945.

Netherlands

Hiversum on *9895* at 1910, Arabic music and songs in the Arabic transmission intended for the Middle East and North Africa and scheduled from 1830 to 1920.

Albania

“Radio Tirana” on *9500* at 1912, OM with the Arabic programme for the Near East and timed from 1900 to 1930.

Afghanistan

Kabul on *4740* at 1915, a programme of local-style music complete with songs rendered by a YL whose trilling cadences were wonderful to hear! The schedule is from 0125 to 0330 and from 1230 to 1930 and is the Home Service 1.

Kabul on *9665* at 1915, OM with a talk on some internal achievements, followed by station identification during the English programme for Europe, timed from 1900 to 1930 but this transmitter is located within the Soviet Union.

Egypt

Cairo on *9805* at 1925, YL with the German programme for Europe, this being timed from 1900 to 2000.

Cameroon

“Radio Yaounde” on *9745* at 1909, OM with a speech in French all about internal events – and to aid station identification I tuned to a parallel broadcast on *5010* – same speech.

Nigeria

Lagos on *15120* at 0730, OM with a newscast mainly of African affairs, all in English. “Voice of Nigeria” station identification preceded the news.

Kaduna on *4770* on 0425, YL with a song and some local-style music in the Channel 2 Service which is in English and Hausa, operating here from 0400 through to 2400. The power is 50kW.

North Korea

Pyongyang on *6576* at 1835, YL with a talk during the French programme for Europe, scheduled from 1700 to 1850.

Pyongyang on *9360* at 0747, YL with announcements at the end of the English transmission intended for Europe and timed from 0600 to 0750. Carrier off at 0752.

Pyongyang on *11985* at 1840, OM with announcements during the Korean programme for Africa, the Near and Middle East, then into some dreamy orchestral music. The schedule of this programme is from 1800 to 1850.

Japan

Tokyo on *21610* at 0800, OM with station identification, programme and frequency details at the commencement of the transmission in English for Europe, timed from 0800 to 0830. A newscast of both Japanese and world events followed.

Australia

Melbourne on *9570* at 0730, OM with station identification and frequencies during the English programme for Europe and the Pacific, scheduled from 0700 to 0900 on this channel.

Melbourne on *9760* at 0740, OM with a newscast in the English programme for Papua/New Guinea and the Pacific Islands, timed from 0700 to 0845.

Ecuador

La Voz de los Caras, Bahia de Caraques on *4795* at 0240, OM with announcements and a programme of local pops during the schedule

1100 to 0430. The power is 5kW.

Radio Nacional Espejo, Quito on 4680 at 0312, OM with a newscast of Latin American events - in Spanish of course. This one operates around-the-clock and has a power of 5kW.

CRE Guayaquil on a measured 4656 at 0314, pop songs, local-style dance music interspersed with many announcements, promos etc. The schedule is from 0900 (Sunday from 1100) to 0500 but the closing time is variable, the power being 10kW.

Peru

Radio Chanchamayo, la Merced on 4895 at 0325, OM with a talk in Spanish about Peruvian events. The schedule here is from 1030 to 0500 (Sunday from 1100 to 0300) and the power is 0.4kW.

Radio Rioja, Rioja on 5045 at 0318, YL with songs in Spanish, local orchestral backing. This one is listed as operating from 1030 to 0400 but the closing time can vary to 0300. The power is not known.

Kuwait

"Radio Kuwait" on 9840 at 1922, when a rather heroic drama was being broadcast in the Arabic Domestic Service, also logged in parallel on 9880. Scheduled here from 1530 to 2115.

"Radio Kuwait" on 15495 at 0608, YL with announcements in Arabic during a programme of western-style dance music in the Domestic/External Service on this channel from 0500 through to 2210 (until 0015 during Ramadan).

"Radio Kuwait" on 21685 at 1433, OM storytelling in Arabic - a favourite local pastime - in the Domestic/External Service, timed here from 1300 to 1600.

Vatican

Vatican City on 9645 at 1946, OM with a newscast during the Italian programme for Europe, transmitted from 1945 to 2015.

Italy

Rome on 9515 at 1950, OM and YL announcers alternate in a relay of the Radio One Domestic Service to the Mediterranean Basin which is transmitted on this channel from 0400 through to 2130.

Rome on 9710 at 1954, interval signal (bird song) at the end of the English programme for the UK, scheduled from 1935 to 1955.

Brazil

Radio Aparecida, Aparecida on 9635 at 2305, OM announcer in Portuguese, pops on records. The schedule is from 0900 to 0300 and the power is 10kW.

Radio Bandeirantes, Sao Paulo on 6185 at 2340, OM with a commentary on a local football (Futebol to them) match. The schedule is from 0800 to 0300 and the power is 10kW.

Radio Iquatemi, Osasco on 3295 at 0144, OM with a ballad in Portuguese complete with local orchestral backing. Heard with some difficulty under a continuous hetro. The schedule is from 0900 to 0300 and the power is 10kW.

Honduras

La Voz de la Mosquitia, Porto Lempira on 4910 at 0204, OM in Spanish with a sports commentary - all exciting stuff! This one is on the air from 1200 to 1400 and from 0000 to 0200 but the closing time can be variable up to 0300. The power is 1kW.

French Guiana

FR3 (France Region 3) Cayenne, on 5055 at 0213, OM with a talk in French in the Home Service, scheduled from 0900 to 1100 and from 2000 to 0300. The power is 10kW.

Now Hear This

Radio Eco, Iquitos, Peru on a measured 5112 at 0249, OM's with a folk song in Spanish complete with piano backing. The schedule is from 1000 to 0500 and the power is 1kW.

YOUR REACTIONS			
	Good	Average	Poor
Circle No.	37	38	39

AUDIO ELECTRONICS

SALE·SALE·SALE

ALL PRICES INCLUDE VAT

EXCLUSIVE OFFERS!

FREE bonus for all orders received by 28/2/83.

MULTIMETERS

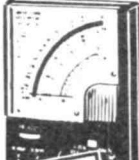

£19.95
£7.95
(UK c/p 65p)

7206 20K/Volt. 19 ranges.
FREE with SG402 below.



£21.60
£15.95
(UK c/p 65p)

7081 50K/Volt. range doubler
FREE with CS1566A below.



£26.95
£18.95
(UK c/p 65p)

2050 50K/Volt plus Hfe Tester
FREE with CS1820 below.

FREE BONUS

Mini stereophones with every 7206/7081/2050 (State 3/8" or 1/4" jack plug)

PLUS FREE METER! See above

TRIO 20 MHZ DUAL TRACE SCOPES

140mm Tube: DC to 20 MHz: 5mV sensitivity: CH2 Invert
CS1820 Delayed sweep: 0.2 usec to 0.5 sec Sweep: Modes CH1, CH2, DUAL and ADD. List Price **£539.00** inc. VAT.
Our Price **£420** inc. VAT (UK c/p £4)

CS1566A NR. AUTO. VIDEO: 0.5 usec Sweep: Modes CH1, CH2, ALT, CHOP and ADD. List price **£368.00** inc. VAT.
Our Price **£299** inc. VAT (UK c/p £4)

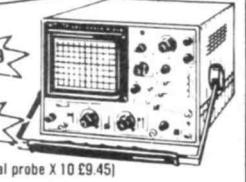

SAVE £119

SAVE £69

(Optional probe X 10 £9.45)

SPEAKERS & TWEETERS

FREE Mini stereophones as above for purchases of £10.00 or more from this advertisement.



HIF20ESM 8 ohm 30/50 watt Bass/Midrange 8" **£5.95**
(UK c/p £1.20)



HIF20ESM 4 ohm Version 8" **£4.95**
(UK c/p £1.20)



HIF87BSM 4" 8 Ohm 30/50 watt midrange **£4.95** (UK c/p 65p)



PH30 3" 8 ohm 15 watt tweeter **£2.20**



HT25 2 1/2" 8 ohm 15 watt tweeter **£1.95**



CN38 3 way 8 ohm 15 watt crossover **£1.25**
(UK c/p Tweeters & Crossovers 65p per 1-3 items)



SN300 40 watt version **£1.75**



HT315F 5" x 3 1/2" 30 watt tweeter **£3.95**

STEREOPHONES • MEGAPHONES • P.A. HORNS



331S 10 watt megaphone with siren **£41.95** **£32.95**
(UK c/p £1.05)

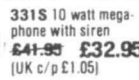

331 without siren **£28.95**
(UK c/p £1.05)



M112 Stereophones padded earpieces: mono/stereo switch: vol. controls **£6.45** **£3.95** (UK c/p 65p)



CH66 6" 10 watt 8 ohm PA Horns **£8.95** **£6.95** (UK c/p 65p)



CR8520 10 to 20 watts 5" Tapped 4 and 8 ohm 20oz **£13.95** **£7.95** pair
(UK c/p £1.05)



CR880 20oz 8 ohm **£11.95** **£7.50**
(UK c/p £1.05)



700 Mains TV boosters back of set **£7.95** **£5.95** (UK c/p 65p)



TMB Masthead (2 TV's) **£16.95** **£12.95** (UK c/p 65p)



SG402 100KHZ to 30 MHZ 6 band Trio RF Generator int/ext. mod. variable o/p to 100mV. AM int 400 HZ mod.
List price **£71.00** inc. VAT
Our Price **£59.95** inc. VAT (UK c/p £2)



DON'T FORGET TO CLAIM YOUR FREE BONUS

ORDER BY POST OR PHONE OR CALL IN AND SEE FOR YOURSELF WELL WORTH A VISIT! ALL OFFERS LIMITED QUANTITIES E & OE

AUDIO ELECTRONICS Cubegate Limited

TEL: 01-724 3564

301 EDGWARE ROAD, LONDON W2 1BN.

ALSO AT HENRY'S RADIO.

404/406 EDGWARE ROAD, LONDON W2

171 for further details

ALL PRICES INCLUDE VAT

Order by Post with CHEQUES ACCESS VISA or Telephone your order. Allow up to 10 days for delivery (unless advised)

CRYSTALS MANUFACTURED TO ORDER

Prices shown are for "one off" to our standard amateur specs; closer tolerances are available. Please send us details of your requirements.

A Low frequency fundamentals in HC13/U or HC6/U

Total tolerance \pm 100ppm 0° to +70°C	
6 to 9-999kHz HC13/U	£32.80
10 to 19-99kHz HC13/U	£31.00
20 to 29-99kHz HC13/U	£23.08
30 to 59-99kHz HC13/U	£21.73
60 to 79-99kHz HC13/U	£15.69
100 to 99-99kHz HC13/U	£13.08
100 to 159-99kHz HC13/6/U	£11.32
160 to 399-99kHz HC6/U	£7.83
400 to 499-99kHz HC6/U	£7.00
500 to 799-99kHz HC6/U	£7.83

B High frequencies fundamentals/overtones

Adj. tol. \pm 20ppm, Temp. tol. \pm 30ppm -10°C to $+60^{\circ}\text{C}$	
800 to 999-99kHz (fund) HC6/U	£11.01
1 to 1-499MHz (fund) HC6/U	£11-25
1-5 to 2-59MHz (fund) HC6/U	£5.36
2-6 to 20-99MHz (fund) HC6/U	£4.87
3-4 to 3-99MHz (fund) HC18 & 25/U	£6.75
4 to 5-99MHz (fund) HC18 & 25/U	£5.36
6 to 21MHz (fund) All Holders	£4.87
21 to 25MHz (fund)	£7.31
25 to 30MHz (fund)	£9.00
18 to 63MHz (3 O/T)	£4.87
60 to 105MHz (5 O/T)	£5.61
105 to 125MHz (5 O/T)	£8.44
125 to 149MHz (7 O/T)	£8.62
149 to 180MHz (9 O/T)	£12.75
180 to 250MHz (9 O/T)	£13.50

Delivery—Mid range 1MHz to 105MHz normally 4/6 weeks.

Other frequencies 6/8 weeks.
Holders—Low Frequencies 6 to 150kHz HC13/U, 150kHz to 3-4MHz HC6/U, 3-4MHz to 105MHz HC6/U, HC18/U or HC25/U, over 105MHz—HC18/U and HC25/U.
 HC33/U (Wire ended HC6/U) is available on request as per HC6/U. HC17/U (Replacement for FT243) available as per HC6/U at 35p surcharge on the HC6/U price.
 Unless otherwise specified, fundamentals will be supplied to 30pf circuit conditions and overtones to series resonance.

CRYSTALS FOR MICROPROCESSORS

Please let us know your requirements eg 4MHz HC18/U. 1 off £2.00, 100 off £1.10, 1000 off 99p, 2500 off 50p.

ANZAC MD-108 DOUBLE BALANCED MIXER

5 to 500MHz supplied with full details for only £6.95.

COMMERCIAL AND PROFESSIONAL CRYSTALS NEW FASTER SERVICE

We are now supplying crystals to most commercial and MIL specifications in the range 1MHz to 60MHz ordered in small quantities in 2½ weeks AT NO EXTRA CHARGE. We also have even faster EXPRESS SERVICES available for that VERY URGENT order.

We can also supply crystals for commercial applications e.g. Microprocessor, TV etc. at very competitive prices. Let us know your needs and we will send you a quote by return, alternatively telephone or telex our Sales Engineer Mr Norcliffe who is normally available in the office for technical enquiries between 4.30 and 6.30p.m.

TWO METRE CRYSTALS

CRYSTAL FREQUENCY USE (TX or and HOLDER)	OUTPUT FREQUENCY										
	4MHz-TX-HC6/U	6MHz-TX-HC25/U	8MHz-TX-HC6/U	10MHz-RX-HC6/U	11MHz-RX-HC6/U	12MHz-TX-HC25/U	14MHz-RX-HC25/U	18MHz-TX-HC25/U	44MHz-RX-HC6/U	44MHz-RX-HC25/U	52MHz-RX-HC25/U
144-4 (433-2)	b	b	b	b	b	b	b	b	b	b	b
144-800	e	e	e	e	e	e	e	e	e	e	e
144-825	e	e	e	e	e	e	e	e	e	e	e
144-850	e	e	e	e	e	e	e	e	e	e	e
145-000/R0T	e	e	e	e	e	e	e	e	e	e	e
145-025/R1T	c	c	c	c	c	c	c	c	c	c	c
145-050/R2T	c	c	c	c	c	c	c	c	c	c	c
145-075/R3T	c	c	c	c	c	c	c	c	c	c	c
145-100/R4T	a	a	a	a	a	a	a	a	a	a	a
145-125/R5T	a	a	a	a	a	a	a	a	a	a	a
145-150/R6T	a	a	a	a	a	a	a	a	a	a	a
145-175/R7T	a	a	a	a	a	a	a	a	a	a	a
145-200/R8R	a	a	a	a	a	a	a	a	a	a	a
145-300/S12	e	e	e	e	e	e	e	e	e	e	e
145-350/S14	e	e	e	e	e	e	e	e	e	e	e
145-400/S16	e	e	e	e	e	e	e	e	e	e	e
145-425/S17	e	e	e	e	e	e	e	e	e	e	e
145-450/S18	e	e	e	e	e	e	e	e	e	e	e
145-475/S19	e	e	e	e	e	e	e	e	e	e	e
145-500/S20	a	a	a	a	a	a	a	a	a	a	a
145-525/S21	a	a	a	a	a	a	a	a	a	a	a
145-550/S22	a	a	a	a	a	a	a	a	a	a	a
145-575/S23	a	a	a	a	a	a	a	a	a	a	a
145-600/R0R	a	a	a	a	a	a	a	a	a	a	a
145-625/R1R	e	e	e	e	e	e	e	e	e	e	e
145-650/R2R	e	e	e	e	e	e	e	e	e	e	e
145-675/R3R	e	e	e	e	e	e	e	e	e	e	e
145-700/R4R	e	e	e	e	e	e	e	e	e	e	e
145-725/R5R	e	e	e	e	e	e	e	e	e	e	e
145-750/R6R	e	e	e	e	e	e	e	e	e	e	e
145-775/R7R	a	a	a	a	a	a	a	a	a	a	a
145-800/R8R	a	a	a	a	a	a	a	a	a	a	a
145-950/S38	a	a	a	a	a	a	a	a	a	a	a

PRICES: (a) £2.15, (b) £2.55, (c) £2.80 and (e) £4.87

AVAILABILITY: (a), (b) and (c) stock items normally available by return (We have over 5000 items in stock). (e) 4/6 weeks normally but it is quite possible we could supply from stock. **N.B.** Frequencies as listed above but in alternative holders and/or non stock loadings are available as per code (e).

ORDERING: When ordering please quote (1) Channel, (2) Crystal frequency, (3) Holder, (4) Circuit conditions (load in pf). If you cannot give these, please give make and model of equipment and channel or output frequency required and we will advise if we have details.

EXPRESS SERVICE

Many types of made to order crystals are available on our "EXPRESS SERVICE"—with delivery of three days on our class "A" service. Telephone for details.

70cm CRYSTALS

Due to the much higher multiplication involved compared with 2 metres all our stock 70cm crystals are to a much higher tolerance than our standard amateur spec. crystals.

We are stocking the following channels:—RB0, RB2, RB4, RB6, SUB, RB10, RB11, RB13, RB14, RB15, SU18 and SU20 TX and RX for use with: PYE UHF Westminster (W15U), UHF Cambridge (U10B), Pocketfone (PF1) and UHF PF70 Range and Storno CQL/COM 662 all at £2.55.

For other channels and/or equipments crystals can be made to order to the same closer tolerances as our stock range at a cost of £5.72 for frequencies up to 63MHz and £6.58 for 63-105MHz or to our standard amateur specifications see "CRYSTALS MANUFACTURED TO ORDER" Prices opposite.

4m CRYSTALS FOR 70-26MHz—HC6U TX8-7825MHz and RX6-7466MHz or 29-7800MHz £2.55.

10-245MHz "ALTERNATIVE" I.F. CRYSTALS—£2.55
 For use in Pye and other equipment with 10-7MHz and 455kHz I.F.s to get rid of the "birdy" just above 145-0MHz. In HC6/U, HC18/U and HC25/U.

CRYSTAL SOCKETS (LOW LOSS)
 HC/6U and HC13/U 25p each, HC25/U 20p each plus 20p P&P (P&P free if ordered with crystals).

CONVERTER/TRANSVERTER CRYSTALS—HC18/U
 All at £3.00, 38-6666MHz (144/28), 42MHz (70/28), 58MHz (144/28), 70MHz (144/4), 71MHz (144/2), 96MHz (1,296/432/144), 101MHz (432/28), 101-50MHz (434/28), 105-6666MHz (1,296/28) and 116MHz (144/28).

TEST EQUIPMENT FREQUENCY STANDARD CRYSTALS
 200kHz and 455MHz in HC6/U £3.50
 100kHz in HC13/U and MHz in HC6/U £2.95
 5MHz in HC6/U and 10MHz and 10-7MHz in HC6/U and HC25/U £2.80.

AERIALS

MULTI-BAND INVERTED "V" TRAPPED DIPOLE
 80 Thru 10m—Rated @ 2kW—Only 26m long.
 Introductory offer £32.00 + VAT (£36.80 INC VAT) P&P £2.50

THE ARAKI RANGE OF AERIALS

10m whip only 1-3m long with magmount	£18.00	P&P £3.00
10m whip only 1-3m long with guttermount	£15.20	P&P £3.00
2m 5/8 λ whip with magmount	£16.00	P&P £3.00
2m 5/8 λ whip with guttermount	£13.20	P&P £3.00
2m 1/4 λ whip with magmount	£12.50	P&P £2.50
2m 1/4 λ whip with guttermount	£9.70	P&P £2.50
2m/70cm DIBAND whip with magmount	£20.90	P&P £3.00
2m/70cm DIBAND whip with guttermount	£18.10	P&P £3.00

2 Base Station Aerials
 2m 5/8 λ Ground plane 3-5db gain £18.95 P&P £3.50
 2m 5/8 + 5/8 Colinear 6db gain £25.00 P&P £3.50
 70cm 5/8 + 5/8 Colinear 5db gain £25.00 P&P £3.50
 The Araki Range are handmade of top quality anti-corrosion treated aluminium or stainless steel.

TERMS: CASH WITH ORDER—MAIL ORDER ONLY.
 PRICES INCLUDE P&P (BRITISH ISLES) EXCEPT WHERE STATED OVERSEAS CHARGED AT COST.

PLEASE ENCLOSE S.A.E. WITH ALL ENQUIRIES

THE TL100 HAS BEEN DESIGNED FOR THE PROFESSIONAL ELECTRONICS, TV OR INSTRUMENT TECHNICIAN. CONSTRUCTED FROM HARD-WEARING ABS WITH STRONG ALUMINIUM FRAMES, TWIN HANDLES AND TOGGLE LOCKS. A MOULDED TRAY IN THE BASE, A COMPREHENSIVE 2-SIDED TOOL PALLET THAT IS REVERSIBLE WITH SPACE FOR OVER 40 TOOLS. THERE IS SPACE FOR DOCUMENTS AND A HEATSINK FOR A HOT SOLDERING IRON.

Also available is the TL99 17in. x 12in. x 6in. £39.90

*** DISCOUNT STRUCTURE FOR MULTIPLE USERS ONLY**

SIZE TL100 19in. x 14in. x 6in. *Tools not included.



£43.70



Enclosed my cheque for £.....

Name: _____

Company: _____

Address: _____

Please send TL100 Professional Toolcases at £43.70 each
 TL99 £39.90. Both inc. VAT (P&P £2.60 extra)

Wychwood, 2 Abbots Kipton Rd., Sapley, Cambs. PE17 2LA. Tel: (0480) 57758

173 for further details

Ray Marston completes his exposition of CMOS gates and takes a brief look at some of the more unusual functions.

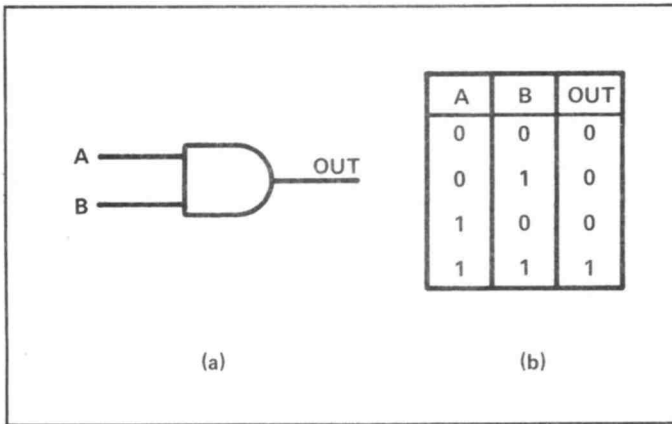

Figure 14: (a) Symbol and (b) truth table of a 2-input AND gate.

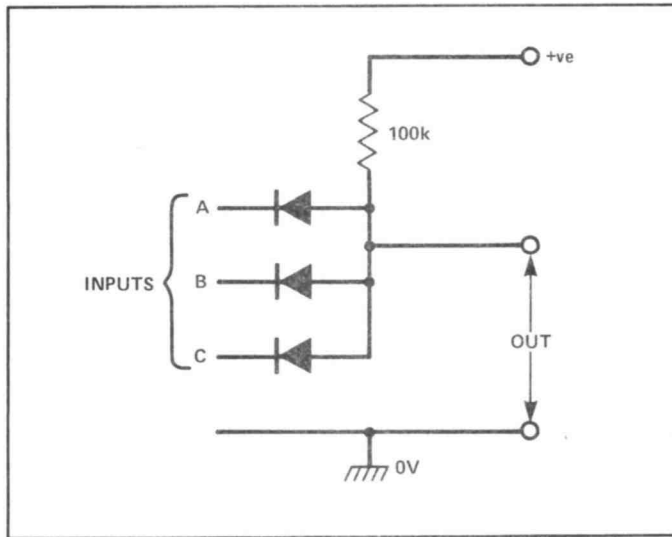

Figure 15: 3-input diode AND gate.

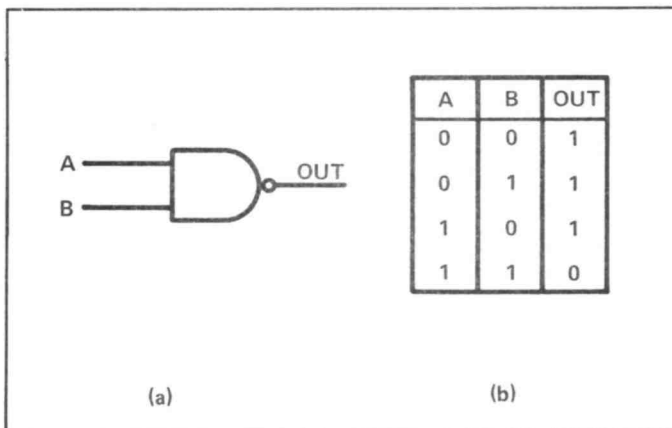

Figure 16: (a) Symbol and (b) truth table of a 2-input NAND gate.

And & Nand Gates

Figure 14 shows the standard symbol and truth table of a 2-input AND gate which, as indicated by its name, gives a high output only when all of its inputs (A AND B, etc) go high. The simplest way to make an AND gate is to use a number of diodes and a single load resistor, as shown in the 3-input AND gate of Fig. 15; more inputs can be obtained by adding one extra diode for each new input.

Figure 16a shows the standard symbol of a 2-input NAND gate (which functions like an AND gate with an inverted output) and Fig. 16b shows its truth table. Fig. 17 shows how a NAND gate can be made from an AND gate and an inverter, and an AND gate can be made from a NAND gate and an inverter. Fig. 18 shows that a NAND gate can be made to act as an inverter and an AND gate can be made to act as a non-inverting buffer either by wiring all but one of the inputs to the positive (logic-1) rail or by wiring all inputs in parallel. Figure 19 shows that the effective number of inputs of an AND or NAND gate can be (a) reduced by wiring all unwanted inputs to the positive supply rail, or (b) increased by wiring extra AND gates to one of the inputs.

Figure 20 gives details of three popular CMOS AND gates, the 4081B quad 2-input type, the 4073B triple 3-input type, and the

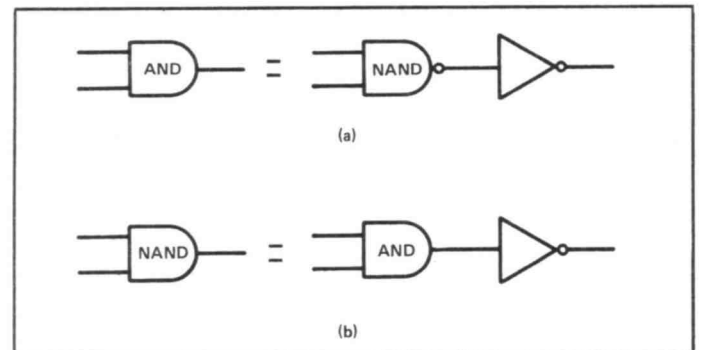

Figure 17: An AND gate can be made from a NAND gate, or vice versa, by taking the output via an inverter.

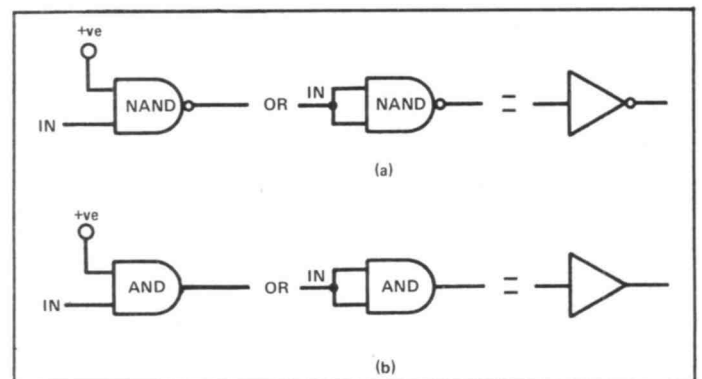

Figure 18: A NAND gate can be made to act as an inverter, and an AND gate can be made to act as a non-inverting buffer.

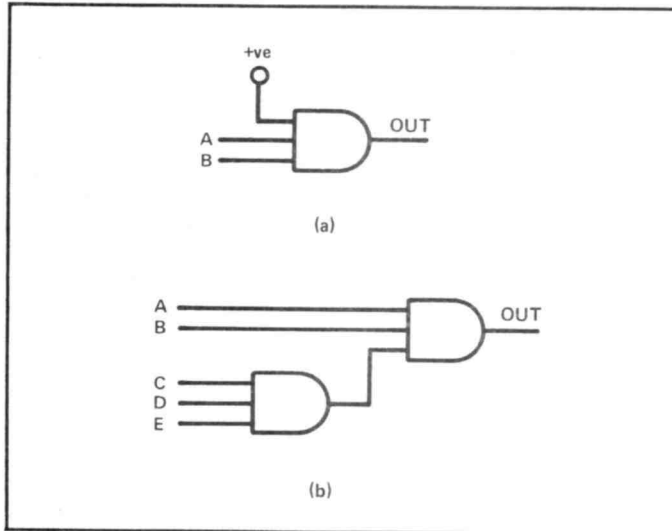

Figure 19: The effective number of inputs of an AND or NAND gate can easily be (a) reduced or (b) increased.

4082B dual 4-input type. Figure 21 gives details of five popular CMOS NAND gates. The 4011, 4023 and 4012 are quad 2-input, triple 3-input and dual 4-input types respectively. The 4068B is an 8-input device with both AND and NAND outputs. The 40107B is a dual 2-input NAND gate, housed in an 8-pin package, with outputs via open-drain n-channel transistors that can (typically) sink 136 mA.

EX-OR & EX-NOR Gates

Figure 22a shows the standard symbol of a 2-input EX-OR (EXclusive-OR) gate, and Fig. 22b shows its truth table. The output of the EX-OR gate goes high only when the two inputs differ. A useful feature of the EX-OR gate is that it can be used as either an inverting or a non-inverting amplifier by wiring or switching one of its inputs either to the positive (logic-1) supply rail (inverting mode) or to ground (non-inverting mode), as shown in Fig. 23.

Figure 24 shows the symbol and truth table of a 2-input EX-NOR gate. This logic element is equivalent to an EX-OR gate with an inverted output. It gives a high output only when both inputs are identical, and is very useful in logic-comparator applications. Figure 25 shows details of the two best known CMOS 'EX' devices, the 4070 quad EX-OR gate and the 4077 quad EX-NOR gate.

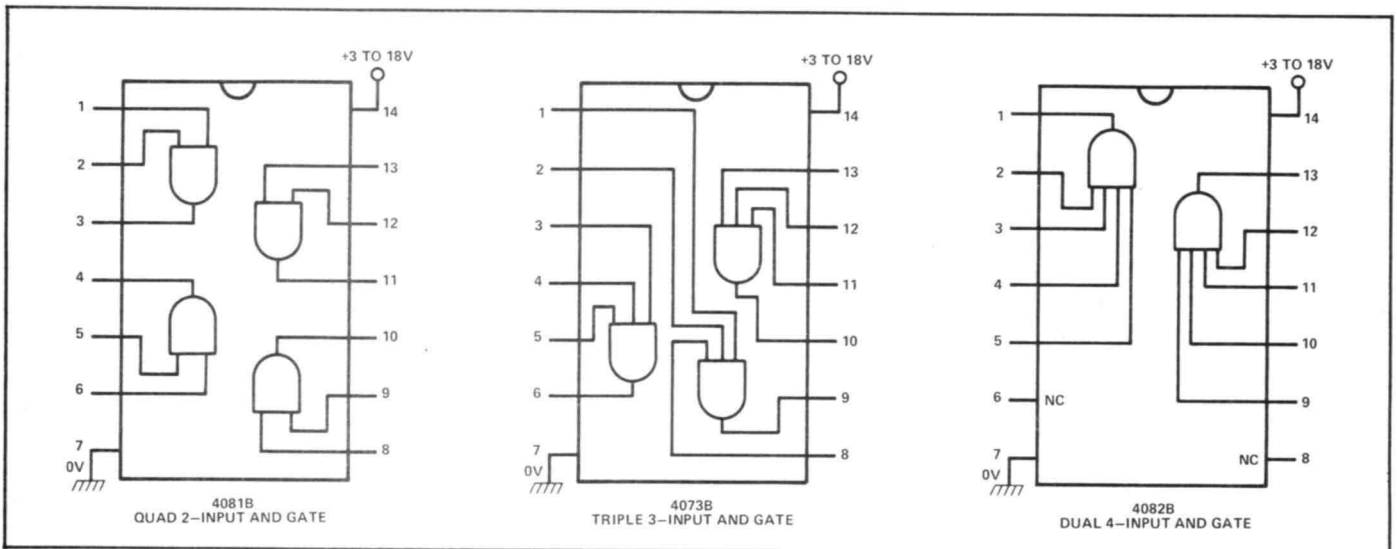

Figure 20: Three popular CMOS AND-gate ICs.

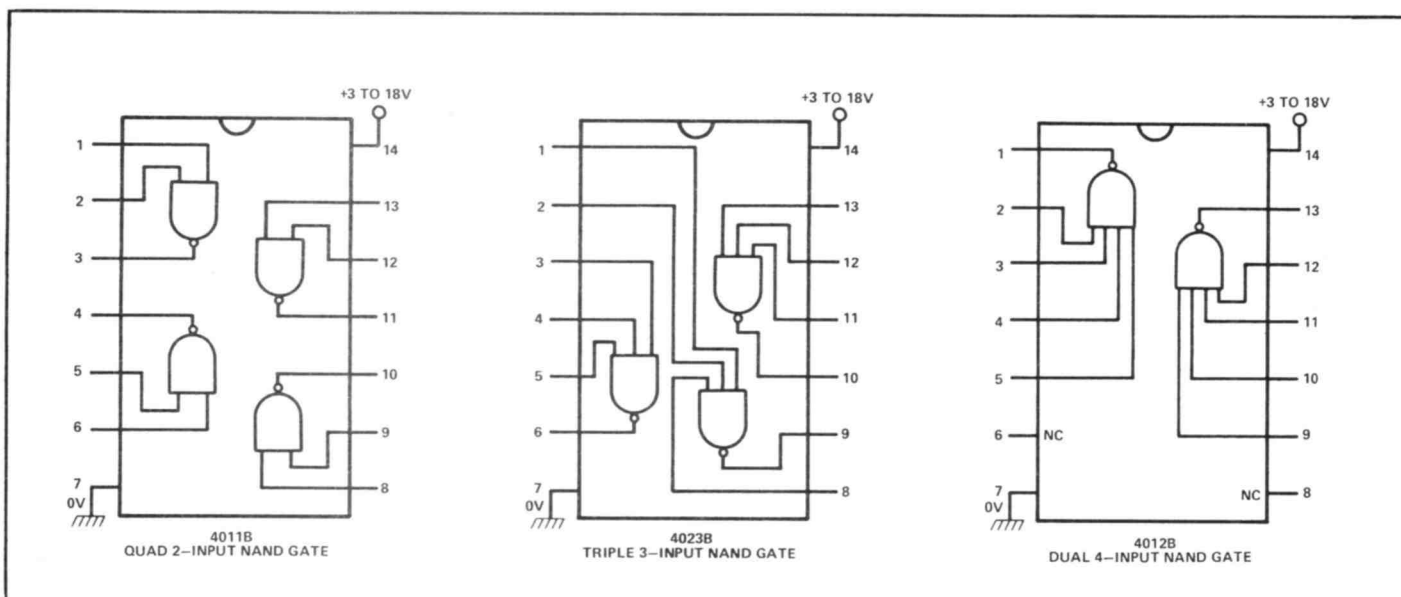

Figure 21: Five popular CMOS NAND-gate ICs.

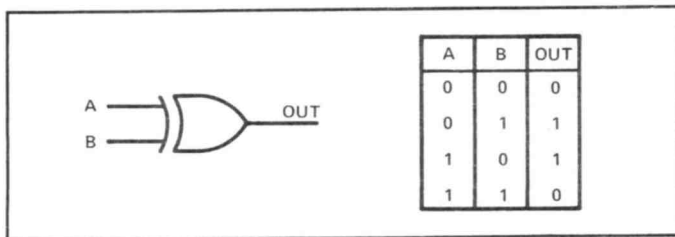

Figure 22: (a) Symbol and (b) truth table of a 2-input EX-OR gate.

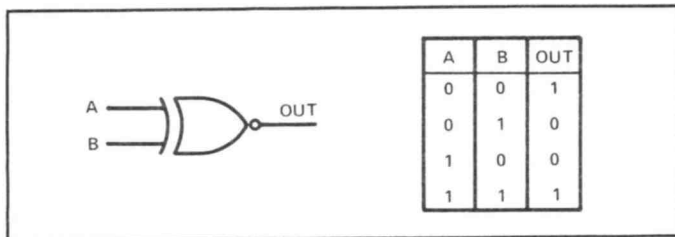

Figure 24: (a) Symbol and (b) truth table of a 2-input EX-NOR gate.

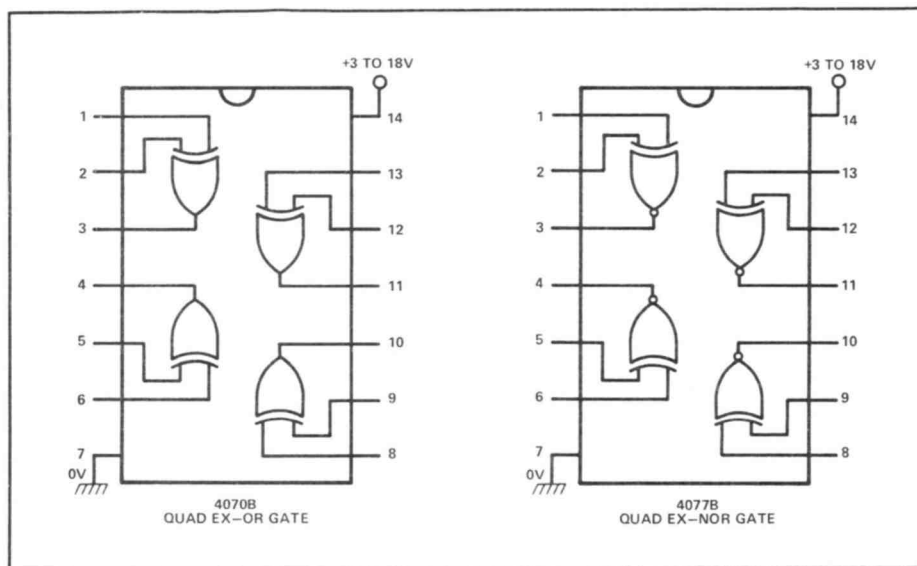

Figure 25: Two popular CMOS 'EX' ICs.

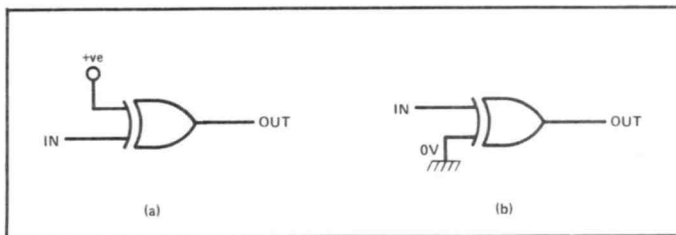

Figure 23: 2-input EX-OR gate connected as (a) inverting and (b) non-inverting amplifier.

Special CMOS Inverters & Gates

CMOS inverters and gates are generally intended to be driven by logic signals that are in either the fully-high (logic-1) or fully-low (logic-0) states. If inputs are allowed to linger between these two states for more than a few microseconds, there is a danger that the inverter/gate will become unstable and act as a high-frequency oscillator, thereby generating false output signals.

Consequently, if "slow" signals are present at one or more of the inputs of a CMOS logic system, these signals must be "conditioned" (given fast rise and fall times) before being applied to the actual logic circuitry. The most useful conditioning element is the Schmitt trigger, and Fig. 26 gives details of two popular CMOS Schmitt ICs, the 40106B hex Schmitt inverter and the 4093B quad 2-input NAND Schmitt trigger.

Most CMOS logic ICs are dedicated devices; eg, the 4082B is a dual 4-input AND gate, and can be used as nothing BUT an AND gate. One very useful exception to this is the 4048B multifunction "programmable" 8-input gate, which has the functional diagram and outline shown in Fig. 27. This IC has two groups of four input pins, plus an EXPANSION input pin, and is provided with four control (K) pins which enable the user to select the mode of logic operation.

Control input Kd (pin-2) enables the user to select either normal (pin-2 high) or high-impedance tri-state (pin-2 low) output operation. The remaining three binary control inputs - Ka, Kb and Kc - enable one of eight different logic functions to be selected, as shown by the table of Fig. 28a, which also shows how to connect unwanted inputs in each mode of operation. Thus, to make the 4048B act as a normal 6-input OR gate, connect the two unwanted inputs to ground (logic-0), and control pins Ka and Kb to ground and pins Kc and Kd to the positive supply rail. The EXPAND input (pin-15) is normally tied to ground.

Eight different logic functions are available from the 4048B, as shown in Fig. 28b. Note that operation in the AND, OR, NAND and NOR modes is quite conventional, but that operation in the remaining four modes (OR/AND, OR/NAND, AND/OR and AND/NOR) is less self-evident. In the later cases the inputs are broken into two groups of four, with each group providing the first part of the logic function, but with the pair of groups

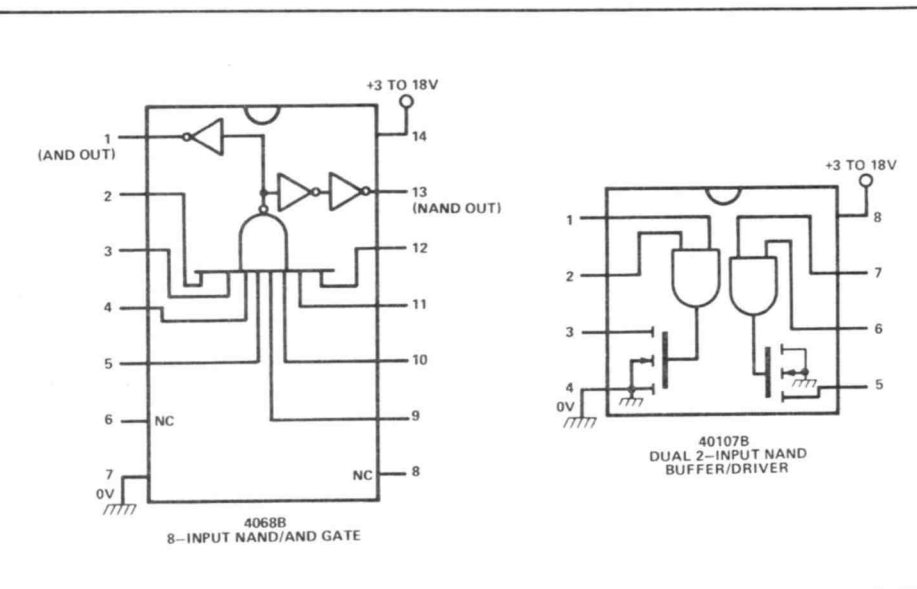

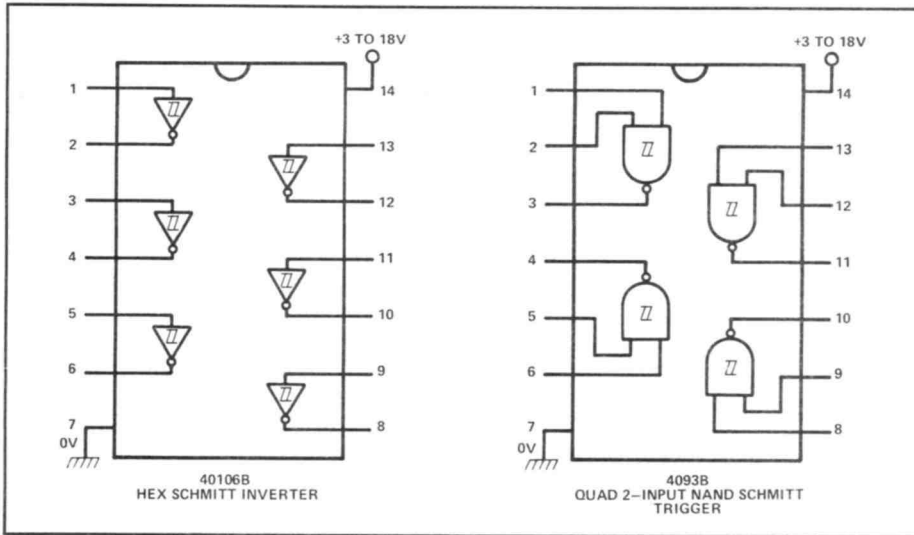

Figure 26: Two popular CMOS Schmitt ICs.

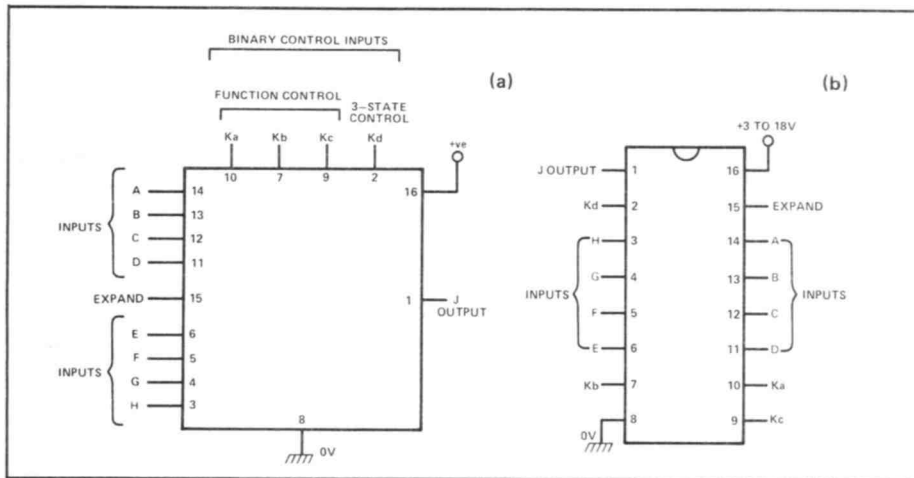

Figure 27: Functional diagram (a) and outline (b) of the 4048B multifunction expandable 8-input gate.

providing the second part of the logic function. Thus, in the OR/AND mode, the circuit gives a high output only if at least one input is present in the A to D group at the same time as at least one input is present in the E to H group.

The EXPAND input terminal of the 4048B enables ICs to be cascaded so that, for example, two ICs can be made to act as a 16-input gate by feeding the output of one IC into the EXPAND terminal of the other. Note when using expanded logic that the input logic feeding the EXPAND terminal is not necessarily the same as the overall logic that is required: Thus, an OR EXPAND input is needed for expanded NOR or OR operation, a NAND EXPAND for AND and NAND operation, a NOR EXPAND for OR/AND or OR/NAND operation, and an AND EXPAND for AND/OR or AND/NOR operation.

OUTPUT FUNCTION	Ka	Kb	Kc	UNUSED INPUTS
NOR	0	0	0	0
OR	0	0	1	0
OR/AND	0	1	0	0
OR/NAND	0	1	1	0
AND	1	0	0	1
NAND	1	0	1	1
AND/NOR	1	1	0	1
AND/OR	1	1	1	1

Kd = 1 FOR NORMAL ACTION
= 0 FOR HIGH-Z OUTPUTS
EXPAND INPUT = 0

Figure 28: Function table (a) and the eight basic logic configurations (b) of the 4048B.

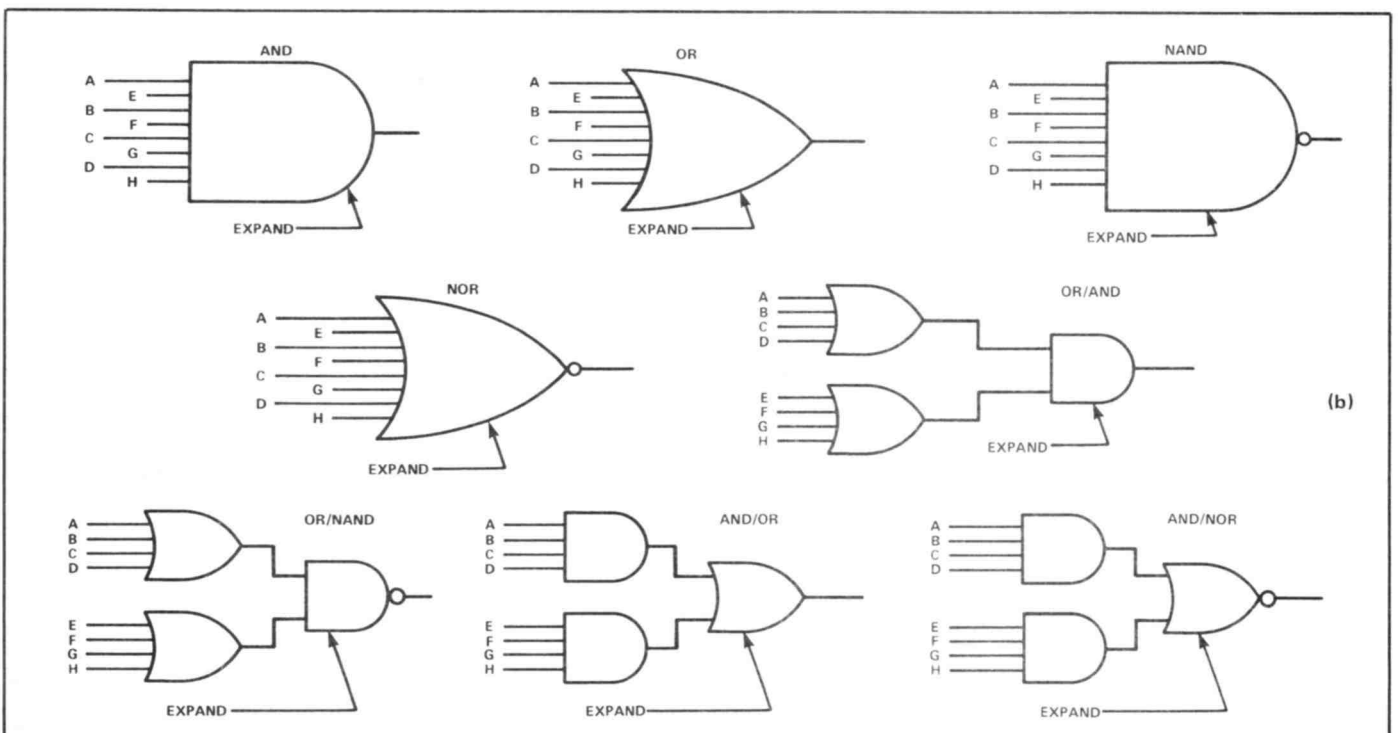

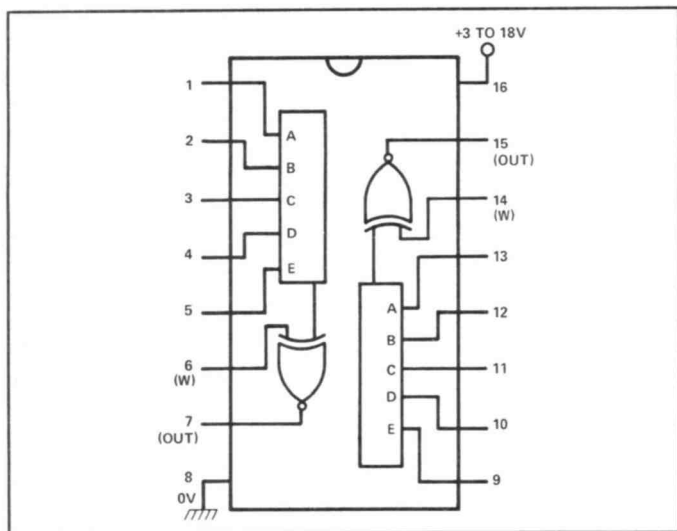

Figure 29: Details of the 4530B dual 5-bit majority-logic gate.

Majority Logic

To conclude this edition of 'Data File', let's take a brief look at a little-known logic system known as MAJORITY LOGIC, in which the logic unit has an odd number of inputs (3,5,7, etc) and gives an output only when the MAJORITY of inputs (2,3,4, etc) are high, irrespective of WHICH inputs are active. This type of logic is useful in some special applications, such as in voting machines and semi-intelligent alarms and robotic devices in which, for example, an alarm bell may sound only if at least two of three detectors indicate a 'fault' condition, or a robot may move only if there is more stimulus to move than there is to stand still.

The best known CMOS majority logic IC is the 4530B dual 5-bit unit (Fig. 29), each half of which contains a 5-input majority logic

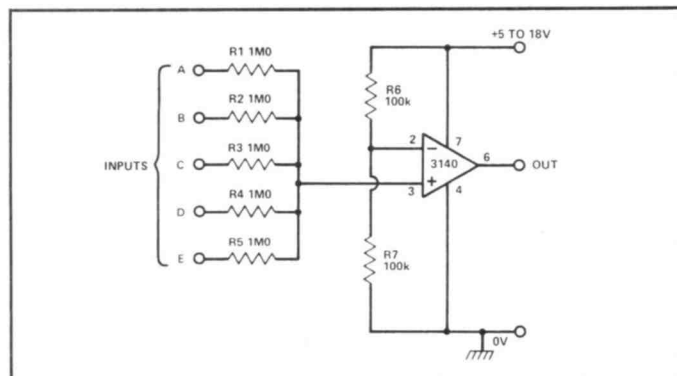

Figure 31: Simple 5-input op-amp majority-logic gate.

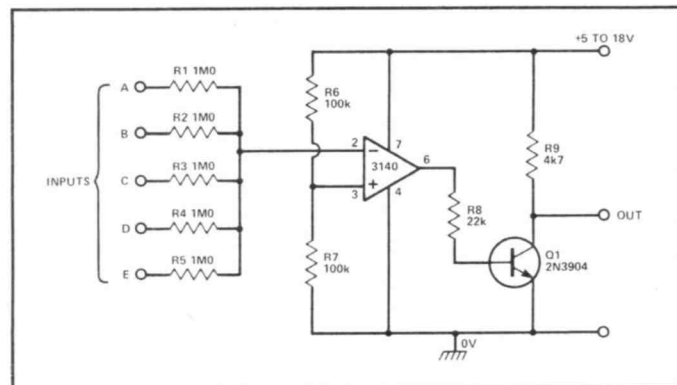

Figure 32: Compound 5-input op-amp majority-logic gate.

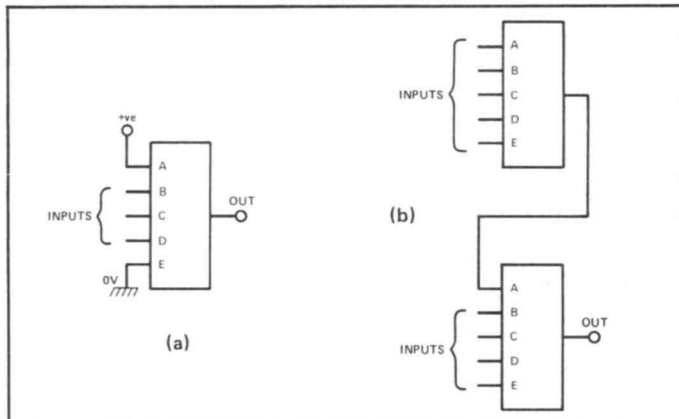

Figure 30: The number of effective inputs of a majority-logic circuit can easily be (a) decreased or (b) increased.

element with its output feeding to one input of an EX-NOR gate that has its other input (W) externally available, enabling it to be wired as either an inverting or non-inverting stage. Thus, when "W" is tied to logic-1, the EX-NOR stage gives non-invert action and the output of the element goes high only when the majority of inputs are high: When "W" is tied to logic-0, the EX-NOR stage gives an inverting action and the output of the element goes high when the majority of inputs are low.

The effective number of inputs of a 4530B can be reduced by wiring half of the unwanted inputs to logic-1 and the other half to logic-0 (Fig. 30a). The effective number of inputs can be increased by cascading elements, as shown in Fig. 30b, taking the output of one element to one of the inputs of the following element.

The 4530B is actually a fairly hard-to-find IC. Fortunately, however, majority logic can easily be created by using a 3140 op-amp in the configuration shown in Fig. 31, which shows a 5-input circuit. Here, the op-amp functions as a voltage comparator, with potential-divider R6-R7 applying half-supply volts to pin-2 of the op-amp, and the five input resistors (which are each connected to either ground or the supply rail) form a potential divider that applies a fraction of the supply voltage to pin-3.

Suppose that two input resistors are connected to logic-0 and three resistors go to logic-1. The three logic-1 resistors have a combined (paralleled) impedance of 333k, and the two logic-0 resistors have a combined impedance of 500k, so the resulting potential-divider voltage on pin-3 is greater than half-supply volts, causing the output of the op-amp comparator to switch high. If, on the other hand, only two of the five inputs are taken to logic-1, the resulting pin-3 voltage is below half-supply value and the op-amp output is switched low. The circuit thus gives "majority-logic" action.

When 5% resistors are used, the Fig. 31 circuit can be given any number of inputs up to a maximum of eleven by simply adding one more 1MΩ resistor for each new input. The output of the circuit switches fully to zero volts when the output is low, but only rises to within a couple of volts of the supply rail value when the output is high. In most applications this defect is of little importance; it does, however, mean that elements cannot be cascaded to increase the effective total number of inputs. This defect can be overcome by using the alternative "compound" configuration of Fig. 32, in which the output is inverted and level-shifted by Q1 and the inputs to the op-amp are transposed. The output of this circuit switches to within 50 mV of either supply rail, enabling units to be cascaded without limit.

■ R&EW

YOUR REACTIONS

	Good	Average	Poor
Circle No.	34	35	36

CLASSIFIED ADS

BARGAIN OFFER

ANNUAL BOUND VOLUMES RADIO & ELECTRONICS CONSTRUCTOR

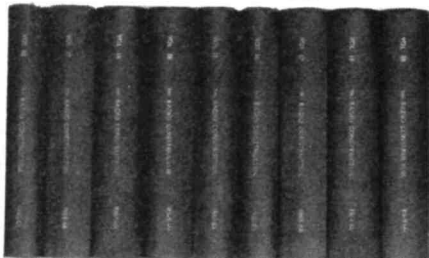

Each of these handsome bound volumes contain more than 150 practical articles in their 700-800 pages of text, published in 12 monthly issues of R&EC.

12 monthly issues to August 1978 (Vol. 31), 1979 (Vol. 32), 1980 (Vol. 33).

* **Volume 33** contains Ian Sinclair's Databus Series — **How Microprocessors Work** Selection & Bussing, CPU Registers; Addressing Memory The Accumulator; Inputs & Outputs; Interrupts; Status Register; Signed Binary Arithmetic; Computing Languages.

ONLY £4.95 each inclusive of post and packing.

Subjects cover - Amplifiers, Amplifier Ancillaries, Calculators, Electronics, 'In Your Workshop', Receivers, Receiver Ancillaries, Television, Test Equipment etc. etc.

12 monthly issues to July 1974 (Vol. 27), 1975 (Vol. 28), 1976 (Vol. 29), 1977 (Vol. 30).

ONLY £3.95 each inclusive of post and packing.

Please send remittance payable to '**RADIO & ELECTRONICS WORLD**' stating volumes required to:—

DATA PUBLICATIONS
45, Yeading Avenue,
RAYNERS LANE, HARROW
Middlesex HA2 9RL

VIDEO GENIE 48K, sound manuals, books, 42 programs including assembler, disassembler, Z chess, startrek. Original packing. £225. Telephone: Rotherham 79647.

SONY ICF2001 £95. SB505D 10M SSB Transceiver, has import licence, 28.5 - 28.95 MHz, £80. GM4DHJ, Phone: 041-889-9010.

PRINTED CIRCUIT BOARDS, NAME-PLATES AND LABELS designed and manufactured. Short and long runs. Prototype PCB's. Artwork and photographic services. We'll try to beat any genuine quotation. G.N. Slee, 78 Derry Grove, Thurnscoe, Rotherham, South Yorkshire, S63 0TP. Tel: (0709) 895265.

SOLAR CELLS. High quality silicon cells. Available 3 inch and 4 inch rounds halves and quarters, plus range of rectangulars. Send s.a.e. for details. Venture Technology, 18 Nuffield Way, Abingdon, Oxon., OX14 1TG. Telephone: Abingdon (0235) 20502.

SONY GLOBAL RECEIVERS for sale. ICF7600 £40. ICF2001 £90. CRF320 £490. Phone: Sharp 01-460-4496. Call:- 26 Coniston Road, Bromley, Kent.

EPROM PROGRAMMING. Prompt service £3/K 2716 eeproms £3 each. ZX81 (radio) hardware/software. Eprom Services, 3 Wedgewood Drive, Leeds, LS8 1EF. Phone: (0532) 667183.

FANTASTIC OFFER. 200 assorted top specification IC's in manufacturers' tubes plus 10 red LED's and 2 opto-isolator IC's (worth £2.50 alone) plus 44 page Catalogue No.19 with many thousands of mechanical and electronic bargains. Price: £6.00 including VAT and postage. J.A. Crew & Co., Spinney Lane, Aspley Guise, Milton Keynes, MK17 8JT.

RESISTORS. 100 £1.70, 400 £6.00, mic. curly lead six core £2.00 each. All including postage. Cooper Communications, 256 Highbury Grove, Cosham, Portsmouth, PO6 2RX.

NARROW BAND F.M. BOARD. 455KHz de-modulator and modulator clamp. Assembled and tested. For amateur/C.B. applications. Size 54 x 44 x 18mm £7.25 plus 25p P&P Receive only version £6.50 plus 25p P&P. EBTC Communications, Chapel Lane, Woodlands, Wimborne, Dorset, BH21 6LU.

CATHOLIC AMATEUR RADIO GROUP. Group has been in operation for past eight years. Would welcome new members. Skeds. arranged to suit. Details: G3AKG, 116 Lowfield Road, Caversham, Reading. Phone: Reading 476718.

V.H.F. TRANSMITTER Tuneable 88MHz - 174MHz £8.50. Available ready built £12.00. Free price list of professional equipment, RF amps, and C.B. spares. S.A.E. Linelink Electrical Engineers Ltd., 35 Marmion Avenue, Chingford, London E4 8EP.

TMS9980 only £21.50. PYE PF1 pocket phone for 70cm, with batts., £26.00. For your car our interior light delay £3.65. Offers advantages over other units. Southern Electronics, 47 Jocketts Road, Hemel Hempstead, Herts., HP1 2JX.

SPECIAL OFFER. Limited supply of plain-backed Cordex Self-Binders. Suitable for 'P.W.', 'P.E.', 'Everyday Electronics' etc. magazine format not to exceed 10" x 8". Available in maroon or green. Price £3.00 inclusive of VAT and P&P. Subscription Dept., Radio & Electronics World, 45 Yeading Avenue, Rayners Lane, Harrow, Middlesex, HA2 9RL.

FT101ZD, FAN, mic and SP901 ext. speaker, £395. Sony ICF2001 receiver, £95. CM4DHJ. Phone: 041-889-9010.

FRG7 Fitted FM £150. 2M-FM 2400, hand held base charger, mobile charger, spare Nicads, microphone case £250. Multimeter £15. A- o.n.o. G8SBU, Fareham, Hampshire. Phone: 0329-232799.

CB SPARES. P.A. transistors, chips, crystals, etc S.A.E. for List: C.F. Shorto Electronic Services, 25 St. Helens Road, Weymouth, Dorset, DT4 9DY.

PROJECT BOXES. Aluminium, steel, plastic. Also Veroboard and accessories. Send s.a.e. to: G6LLZ, 14 St. Peters Road, Wisbech, Cambs.

SEND S.A.E. FOR LISTS OF NEW COMPONENTS at silly prices: i.e. TBA950, 2SC2029, 2SC2078 £1.80 each. Briandene, Fackley Road, Teversal, Sutton-in-Ashfield, Notts.

CHARTS AND ABACS. Set of five with instructions for quick calculations of Ohms Law, inductance, capacity, resistance, etc. Only £5.00, including postage from: G.W. Services, 1A Grosvenor Crescent, Dartford, Kent, DA1 5AP.

R.S. 3U instrument case, sub rack kit modules, card fronts, runners plus 2 edge connectors. Ideal for test equipment or micro. £25. Phone: 0279-504212.

HAMS, SWLS, BUYING OR SELLING GEAR. Send for details of a unique new service for buying and selling. S.A.E. please. Stanton, EMR, 35 Upper Tything, Worcester, WR1 1JZ.

SUPERB SPEC. COUTANT 20A D.C. Power supply cont. rated 6 to 30V. Output 1000+ VA. As new £65 collected. Telephone (0533) 55 2809 evenings/weekends

S/HAND MOBILE RADIOS for sale. High Band and low band. Westminster, Cambridges. Vanguard and many others. Box No. REW30.

POWER MOSFET 4-400W Drive Module 50 x 50 x 30mm with instructions. £7.00. Vicelec, 30 Crosby Road, Southport, Merseyside, PR8 4TE.

CLASSIFIED ADS

T&J ELECTRONIC COMPONENTS

Quality components, competitive prices. Send 45p cheque or postal order for illustrated catalogue, 98 Burrow Road, Chigwell, Essex IG7 4BH.

AUDIO: VIDEO: DATA TRANSMISSION.

Professional grade cables from **TRANSOUND/FILOTEX**. Made by Europe's premier cable manufacturers. Example: EHEA shielded twin-twisted "easy Strip" audio cable (once used you will use no other) 100 metres £25.00. Total which includes P&P and VAT (UK only). CWO. For data sheets, large quantity discounts, exports, etc. SAE to: Transound International Electronics Ltd., PO Box 148, Welwyn Garden City, Herts. Or telephone 043-879-262.

G4BVS COMPUTERISED MORSE TRAINER

for Apple II (48K DOS 3.3). Sophisticated program allows comprehensive structured training in both receiving and transmitting morse code in various modes²eds.pitches. Automatic scoring and instantaneous visual fully G4BVS/REW, 22 Highland Road, Amersham, Bucks HP7 9AX, or £9 to include disk.

AERIALS: TELEVISION, RADIO, CB,

(91-elem. wide band UHV DX aerials), Masthead amplifiers, poles, brackets, towers and CB radios. London's cheapest! AAC Ltd., 132 Hermon Hill, London E18. Telephone 01-530-6118.

AIRCRAFT COMMUNICATIONS

HANDBOOK (Europe) including UK Spot MF, HF, VHF, UHF. Frequencies, military and civil airports, air traffic control centres, weather reports, broadcast times, beacons, long range stations, call signs, maps, etc. 384 pages £7.50, post & packing £1. PLH Electronics, 97 Broadway, Frome, Somerset.

RADIO & ELECTRONICS CONSTRUCTOR

back issues for volume 34, Sept 1980 to Aug/Sept 1981, all twelve issues in handsome Cordex Binder with title on spine for only £5.60 plus £1.60 for p&p. From Data Publications, 45 Yeading Avenue, Rayners Lane, Harrow, Middx HA2 9RL.

JOIN THE INTERNATIONAL SW

LEAGUE. Free services to members including QSL Bureau, Amateur and Broadcast Translation, Technical Identification Dept. - both Broadcast and Fixed Station, DX Certificates, contests and activities for the SWL and transmitting members. Monthly magazine **MONITOR** containing articles of general interest to Broadcast and Amateur SWLs, Transmitter Section and League affairs, etc. League supplies such as badges, headed notepaper and envelopes, QSL cards, etc. are available at reasonable cost. Send for league particulars. Membership including monthly magazine etc., £9.00 per annum UK overseas rates on request, Secretary, 88, The Barley Lea, Coventry, W. Midlands.

THE RADIO AMATEUR INVALID AND

BLIND CLUB is a well established Society providing facilities for the physically handicapped to enjoy the hobby of Amateur Radio. Please become a supporter of this worthy cause. Details from the Hon Secretary, Mrs R E Woolley, 9 Rannoch Court, Adelaide Road, Surbiton, Surrey KT6 4TE.

WRITE FOR R&EW

We pay good rates to authors for articles covering the latest developments in electronics, communications, video and computing. If you have an idea for a project or a feature write, with brief details, to the Editor at the usual editorial address.

SMALL ADVERTISEMENTS

Advertisements must be prepaid and all copy must be received by the 4th of the month for insertion in the following month's issue.

The Publishers cannot be held liable in any way for printing errors or omission, nor can they accept responsibility for the **bona fides** of Advertisers.

Where advertisements offer any equipment of a transmitting nature, readers are reminded that a licence is normally required. Replies to Box Numbers should be addressed to: **Box No....., Radio & Electronics World, 45 Yeading Avenue, Rayners Lane, Harrow, Middlesex HA2 9RL.**

CLASSIFIED ADVERTISEMENT ORDER FORM - PLEASE COMPLETE BELOW

- Write Your Ad. Below** In the boxes - one word per box please. Underline words required in **Bold** type. Your name, address, and/or telephone number, if to appear, must be included in the boxes and must be paid for. Telephone numbers count as two words. Please use **BLOCK CAPITALS**.
- Advertisements are accepted on the understanding that the details stated comply with the conditions of the Trade Description Act, 1968.
 - Whilst every care is taken to ensure accuracy, we do not accept liability for inaccuracies should they occur.
 - Cancellations must be notified by telephone or in writing by the 6th of the month preceding publication.

			£2.00
£2.04	£2.16	£2.28	£2.40
£2.52	£2.64	£2.76	£2.88
£3.00	£3.12	£3.24	£3.36
£3.48	£3.60	£3.72	£3.84
£3.96	£4.08	£4.20	£4.32

RATES

All cheques should be made payable to Radio & Electronics World.

12p per word -
minimum charge £2.00

Tick this box if you
require a box number
charged at 30p

I enclose remittance of £ : p

NAME

ADDRESS

POSTCODE

Post your completed form to **RADIO & ELECTRONICS WORLD, Classified Ads., 45, Yeading Avenue, Rayners Lane, HARROW, Middlesex.**

Gary Evans with . . .

This issue of **R&EW** was prepared amongst hurried preparations for the Electronic Hobbies Fair which, by the time you read this, will have been and gone. It cannot have escaped many peoples' notice that this year saw, in addition to the Hobbies Fair, the annual Breadboard event. These two exhibitions are aimed fairly and squarely at the hobbyist market and the fact that they took place within days of each other can have pleased nobody. Both the trade and the public were faced with the decision to attend both, spending a lot of time and money in the process, or to put in an appearance at only one, with the nagging worry that they might miss out on something.

I can remember the first Breadboard Show and the excitement it promoted along with the general thought of "why had nobody done it before". Until that first Breadboard the hobbyist market did not have an exhibition of its own, yet the monies spent by electronic DIYers ran into many millions of pounds per annum.

The first show was a tremendous success and Breadboard was firmly on the map.

Going Down

In subsequent years Breadboard, while still serving the interests of the hobby market, provoked an increasing dissatisfaction amongst exhibitors and visitors alike. The most common causes for complaint were the high price of admission and the general lack of organisation behind the scenes.

The gradual lowering of standards over the years could have been due to the fact that Breadboard had the field to itself and it was reckoned that a bit of competition might not be a bad thing. This year Breadboard does have some competition but the fact that it comes within days of Breadboard closing is a bad thing.

The almost head on clash of this year's events may have something to do with the fact that the two shows are organised by different publishing houses, between which there is no love lost.

It is unlikely that Breadboard will be frightened off by the Hobbies Fair and similarly it is a fair bet that the Hobbies Fair will be with us next year.

Let us hope that the rivalry between the two shows results in better exhibitions and that next year one or other of them moves to

March or April giving both trade and public two, well organised events, with a decent interval between them.

Le Crunch

Our new Assistant Editor had his fair share of bad luck this month - its all to do with a fatal combination of video recorders automobiles and a female PR person.

It all started with a rush review of a video recorder that was much in demand amongst the various video magazines. **R&EW** picked the machine up from the offices of one video title on a Friday night promising to deliver it to the PR company on the Monday.

The story now switches to a telephone romance that had been developing between our Assistant Editor and a member of the PR company's staff. Delivering the recorder would allow a face to be put to the voice and thus it was an eager Mr. Coster and not Securitor that set out from Brentwood on the Monday morning.

About two hours later the **R&EW** phone rang with a slightly shaken Paul Coster at the other end of the line. The unfortunate young man had got within two miles of his rendezvous when some unthinking motorist drove into the back of his car.

Having ascertained that the recorder was intact we went on to extract more details about the bump. Apparently the other driver and driven into Mr. Coster's car, causing considerable damage, and then disappeared into the traffic on the North Circular Road. It's a good job that his front number plate was firmly embedded in the back of our Assistant Editor's car otherwise it might have proved difficult to trace the other driver.

Having sorted out the mess it was rather too late to deliver the recorder and the PR company, erring on the side of caution, arranged to pick the machine up the next morning.

Paul never got to see his lady but has, we hear, arranged another meeting in the near future. This time he'll go by train.

In the meantime, if the owner of the number plate JPO 2X would like to call us we know someone who'd like a few words.

THE LAST WORD.

Advertisers' Index

Ambit International	66	Garex	14
Amtron U.K.	9	G.S.C.	7
Audio Electronics	87	Intermedial	47
Blackstar	69	H. Lexton	I.B.C., 3
BNR & ES	52	Microwave Modules	23
Branime	8	M.J.L.	6
Bulgin	O.B.C.	O.E.L.	58
Burns	6	Olson Electronics	2
C. Q. Centre	79	P.M. Electronics	88
E. I. Chessel	79	Randam Electronics	66
Datong	31	Riscomp	2
Eddystone Radio	3	S.E.M.	23
Electrautom	58	Teloman	88
Electronize Design	4	Wilmslow Audio	8, 66
European Crystals	58		
Fieldtech Heathrow	14		

EAST LONDON HAM STORE

H. LEXTON LIMITED

191 FRANCIS ROAD LEYTON E.10
TEL 01-558 0854 TELEX 8953609 LEXTON G

DRESSLER AMPLIFIERS

These are high power 240V linears using 4C x 150 or 4C x 250 or 4C x 350 Eimac Tubes NOT using the grounded Grid system. Fully protected, no thermal damage to PA finals possible.



DRESSLER AMPLIFIERS

D70 70cm 200wfm 400 PEP	£495.00
D200c 2mtr 125wfm 200w PEP	£285.00
D200 2mtr 300wfm 600w PEP	£495.00
D200S 2mtr 400wfm 1KW PEP	£600.00

GASFET DRESSLER PRE-AMPS

VV2	£40.00
VV200GAAS 150W	£69.00
VV200GAAS 750W	£79.00
VV200GAAS 1KW	£79.00
VV2RPS S0259	Not switching £22.00
VV2RPS N Type	£24.00
VV7RPS S0259	£22.00
VV7RPS N Type	£24.00

Powered by the linear or with separate interface.
0.7 - 0.9dB signal to noise
0.2dB insertion loss

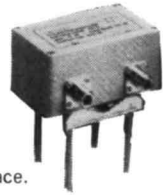

GASFET MASTHEAD PREAMPS

3SK97 GASFET Available separately £4.50

WE WOULD LIKE TO WISH A MERRY CHRISTMAS
AND A PROSPEROUS NEW YEAR TO ALL OUR CUSTOMERS

ICOM

IC740 HF 100W	£699
IC720RHF 100W G/C	£899
IC730 HF 100W	£586.00
IC2KLL Linear	£829.00
IC2KLP5 P.S.U.	£211.00
PS15 P.S.U.	£99.00
PS20 P.S.U.	£130.00
AT500 A.T.U.	£299.00
RX70 Receiver	£469.00
PS15 P.S.U.	£99.00

ICOM

IC2E 2mtr fm portable	£159.00
IC4E 70cm fm portable	£99.00
IC25G 2mtr 25w fm	£235.00
IC290 2mtr 10w fm/ssb	£366.00
IC251 2mtr 10w fmkw/ssb/base	£495.00
IC451 70cm 10w fmkw/ssb/base	£630.00
IC490 70cm fm/ssb mobile	£445.00
ICSP3 Speaker	£29.00
ICSM5 Mic	£29.00

ICOM

Accessories	
ICLC/1/2/3 case	£ 4.25
ICWM9 SP/Mic	£ 12.00
ICBP2 6V pack	£ 29.50
ICBP3 9V pack	£ 20.00
ICBP4 empty pack	£ 6.95
ICBP5 12V pack	£ 39.50
ICCP1 charging lead	£ 3.75
ICDC1 12V car pack	£ 9.75
LC8 leather case	£ 18.98
BC30 Base Charger	£ 45.00

TRIO/KENWOOD

TS930 General Coverage RX/TX	£995.00
TS830 100W HF	£650.00
TS530 100W HF	£475.00
TS130 100W HF	£495.00
TS130 25W 2mtr FM/SSB	£390.00
TS7850 40W 2mtr FM	£300.00
TS7800 25W 2mtr FM	£245.60
TR2500 2mtr Portable	£200.00
TR7730 2mtr FM	£245.00
AT230	£110.00
SP230	£34.00
DM801 GDO	£60.00
R600 Receiver AM/SSB	£190.00

YAESU

FT-one gen. coverage TX/RX	£1295.00
FT102 150W 10mtr-160mtr	£690.00
FT707 100W 5-10mtr	P.O.A.
FT707 20A P.S.U.	P.O.A.
FC707 A.T.V.	P.O.A.
FT107M 9 band 100W	P.O.A.
FP107 P.S.U.	P.O.A.
FT107ZD 160-10mtr	P.O.A.
FT9020M 160-10mtr AM/FM	P.O.A.
SP901 Speaker	£ 30.00
FC902 A.T.U.	£135.00
FL2100Z 1.2KW PEP linear	£425.00
FC102 Speaker	P.O.A.
FC102 A.T.U.	P.O.A.
FM102 V.F.O.	P.O.A.

YAESU

FT290R with mods FM/SSB	£245.00
FT480R 2mtr mobile FM/SSB	£365.00
FT780R 70cm 7.6swift Shift	£440.00
FT780R 70cm 1.6 swift Shift	£440.00
FT208 2mtr portable FM	£195.00
FT708 70cm portable FM	£205.00
FT230 2mtr FM mobile	£220.00
FRG7700 receiver AM/FM/SSB	£295.00
FRG7700 memory	£ 80.00
FRV7700A 118-150	£ 60.00
FRV7700B 50-60/118-150	£ 75.00
FRV7700C 140-170	£ 65.00
FRV7700D 70-80/118-150	£ 72.00
FRV7700E Aerial Tuner	£ 37.00
FRA7700 Active Antenna	£ 36.00
FF5 Filter	£ 9.95
MMB11 FT290 Car Mount	£ 22.00
NC11C Charger	£ 8.00
NCB Base Charger	
FT208/208 108	£ 44.00

MORSE READERS

+ Tasco Telereader	
CW/RTTY	£250

DIAWA

RM940 Mic Infrared	£ 45.00
CN620A 1KW SWR	£ 52.81
CN1001 Auto A.T.U.	£156.00
CN2002 2KW Auto A.T.U.	£228.00
CN518 2.5KW A.T.U.	£175.00
AF406 Active Filter	
AF606 P.L.L. Active Filter	£ 56.00

DR7500X

DR7500X	£95.00
DR7500R	£100.00
DR7600X	£135.00
DR7500R	£145.00

Morse Readers

MBA electronic morse/RTTY reader	£170.00
Microdot/morse/RTTY printer/VDU/Key Board all one price	£650.00

DATONG

D70 Morse Tutor	£ 56.35
PC1 Gen. cov converter	£137.00
FL1 Agile filter	£ 79.35
FL2 Active filter	£ 89.70
FL3 Agile filter & notch	£129.37
ASP Auto clipper	£ 82.80
D75 Manual clipper	£ 56.35
RFC Speech clipper	£ 29.90
AD270 Indoor active ant	£ 47.15
AD370 Outdoor active ant	£ 64.40
RFA Wide band AMP	£ 33.92

WELTZ

SP200 1.8-160MMZ 20-200-1KW	£ 59.00
SP300 1.8-500MMZ 20-200-1KW	£ 79.00
SP400 130-500MMZ 5-20-150	£ 59.00
SP250 1.6-60MMZ 20-200-2K	£ 43.00
SP15 1.08-160MMZ 5-20-200	£ 29.95
CT150 150/400W Dummy Load	£ 31.00
AC38 3.5 30MMZ A.T.U.	£ 59.00
SP10X 108-150MMZ 20-20n	£ 19.95

DURING DECEMBER OUR PREMISES WILL BE
OPEN SUNDAY FROM 10-3

MORSE KEYS

Morse keys Swedish brass key	£49.00
Himound HK706	£ 11.00
Himound MK706	£ 20.00
Himound HK7022	£ 22.50
Kenpro squeeze key 100 electronic key	£ 57.00
Dawa DK210 Electronic keyer	£41.00

POWER SUPPLIES

The Lexton 7amp Max 12amp	£ 49.95
20ampMax 22amp	£ 79.95
Fully protected against overvolts, over current S/C protected & RF protected	
Trade enquiries invited and own name can be provided	

SONY

ICF2001 receiver	£140.00
Microwave modules	
MML 144/30 1-3w drive	£ 9.95
MML 144/100 L.S. 1-3w drive	£159.95
MML 144/100 S10Wdrive	£139.95
MMC 435/600 ATV converter	£ 27.90
MM2001 RTTY receiver	£199.00
MM4000 RTTY tranceiver	£269.00
MM1000KB key board + tranceiver	£299.00
MMT28/144	£109.95
MMD050 frequency counter	£ 75.00
+ ALL MODELS STOCKED	

TONO

2M - 50W Linear amp. 1-3Win	£ 62
2M - 70W Linear amp. 10Win	£ 90
2M - 100W Linear amp. 10Win	£115
Ø 500 - CW/RTTY Terminal	£299.00

SCANNING RECEIVER

Scanning Receiver SX200N	£249.00
--------------------------	---------

ROTATORS

Kenpro KR 250	£ 44.95
Hirshmann HR 250	£ 50.00
Kenpro KR400RC	£100.00
Kenpro elevation rotator	£85.00

TONNA

144 4ELE	£12.00	432/440 21 ELE	£19.00
144 9ELE	£16.00	432/435 21 ELE A.T.V.	£27.00
144 9ELE crossed 30.0	£44.35	9 19ELE	£31.00
144 9ELE portable 30.0	£144	19ELEX	£30.00
144 16ELE	£33.00	1296 23ELE	£27.00
144 13ELE portable	£29.00	Phasing Harness	
430/440 19ELE crossed telescopic masts			
435 19ELE			£19.00

TET

HB33T	£189.00	HB35C	P.O.A.
HB34T	£202.00	SQ22144	£ 55.00
HB35T	P.O.A.	SQ220X144X4	£ 90.00
		SQ007 70cm	P.O.A.

See the new standard C5800 Multimode 25W SSB/FM/CW 2Mtr £359.00

JAYBEAM

TB3 HF 3 band	£181.70	5XY2M	£24.70
VR3 band vertical	£ 46.00	8XY2M	£31.00
C52M colinear	£ 47.72	10XY2M	£40.80
5Y2M 5ELE YAGI	£ 12.00	Q4/2M	£25.80
8Y2M 8ELE YAGI	£ 15.50	Q6/2M	£33.90
10Y2M10ELE YAGI	£ 33.00	Q8/2M	£39.00
PBM1010EPARABEAM	£39.50	MBM548/70cm	£31.00
PBM1414EPARABEAM	£48.00	MBM88/70cm	£42.50
		8XY 70cm	£36.80
		12XY 70cm	£46.00

HOXIN

GP5 2mtr colinear	£33.00	DX1 discone TX-TX	£ 34.00
6.4DB		HF5DX 80-40-20-15-10 mtr	£84.00
		Vertical	

ALL ACCESSORIES AVAILABLE - PLUGS SKTS CO-AX 2MTR COLINEAR £31.50, 70CM COLINEAR £31.50



PRICES INCLUDE VAT AT THE PRESENT RATE OF 15%
OPEN MON-FRIDAY 9:00-5:30. SATURDAY 10:00-3:00. INSTANT HP FACILITY AVAILABLE
EASY ACCESS M2-M11-M1 NORTH CIRCULAR ROAD-EASY PARKING



BULGIN MULTIRANGE CONTROL KNOBS

A UNIQUE BLEND



More combinations of size,
finish, cap, skirt, push fit, collet etc.

now available from **Ambit International**

200, North Service Road, Brentwood, Essex CM14 4SG

Circle No. 200